

Tektronix[®]

COMMITTED TO EXCELLENCE

Please Check for
CHANGE INFORMATION
at the Rear of this Manual

**606B MONITOR
WITH OPTIONS**

SERVICE MANUAL

Tektronix, Inc.
P.O. Box 500
Beaverton, Oregon 97077

MANUAL PART NO.
070-2821-00

Download from www.Somanuals.com. All Manuals Search And Download.

First Printing SEP 1979
Revised JAN 1981

WARNING

This equipment generates, uses, and can radiate radio frequency energy and may cause interference to radio communications if not installed and used in accordance with the instruction manual. It has been tested and found to comply with the limits for Class B computing devices pursuant to Subpart J of Part 15 of FCC Rules, which are designed to provide reasonable protection against such interference when this equipment is operated in a commercial environment. Operation in a residential area is likely to cause interference in which case the users at their own expense must take whatever measures may be required to correct the interference.

Copyright © 1979 Tektronix, Inc. All rights reserved.
Contents of this publication may not be reproduced in any form without the written permission of Tektronix, Inc.

Products of Tektronix, Inc. and its subsidiaries are covered by U.S. and foreign patents and/or pending patents.

TEKTRONIX, TEK, SCOPE-MOBILE, and  are registered trademarks of Tektronix, Inc. TELEQUIPMENT is a registered trademark of Tektronix U.K. Limited.

Printed in U.S.A. Specification and price change privileges are reserved.

TABLE OF CONTENTS

	PAGE		PAGE
LIST OF ILLUSTRATIONS	iii	DYNAMIC FOCUS	3-6
LIST OF TABLES	iii	X ABSOLUTE VALUE AMPLIFIER	3-6
SAFETY SUMMARY	iv	Y ABSOLUTE VALUE AMPLIFIER	3-6
SECTION 1—GENERAL INFORMATION		STIGMATOR 1 CORRECTION SHAPER	3-7
OPERATORS MANUAL	1-1	STIGMATOR 1 OUTPUT AMPLIFIER AND	
SERVICE MANUAL	1-1	LEVEL SHIFTER	3-7
INSTRUMENT DESCRIPTION	1-1	REMOTE DEFOCUS	3-7
INSTALLATION	1-2	STIGMATOR 2 CORRECTION SHAPER	
INITIAL INSPECTION	1-2	AND MIXER	3-7
OPERATING POWER INFORMATION	1-2	STIGMATOR 2 OUTPUT AMPLIFIER AND	
INSTALLATION IN PATIENT-CARE FACILITIES	1-3	LEVEL SHIFTER	3-7
INPUT ATTENUATION	1-3	FOCUS CORRECTION SHAPER AND MIXER	3-8
INPUT IMPEDANCE	1-5	Z FOCUS	3-8
RACKMOUNTING INFORMATION	1-5	FOCUS OUTPUT AMPLIFIER	3-8
CABINET-TO-RACKMOUNT CONVERSION	1-5	CONVERTER AND HIGH-VOLTAGE	
RACKMOUNT-TO-CABINET CONVERSION	1-5	POWER SUPPLY	3-8
SLIDE-OUT TRACKS	1-5	CONVERTER OSCILLATOR	3-8
REMOVING OR INSTALLING THE		ERROR AMPLIFIER	3-8
INSTRUMENT	1-5	CURRENT LIMITER	3-8
SLIDE-OUT TRACK LUBRICATION	1-5	CONVERTER BASE DRIVE	3-9
INSTRUMENT PACKAGING	1-5	CONVERTER OUTPUT	3-9
SPECIFICATION	1-7	DEFLECTION VOLTAGE SUPPLIES	3-9
STANDARD ACCESSORIES	1-12	H. V. REGULATOR	3-9
		CONTROL-GRID DC RESTORER	3-9
		FOCUS-ELEMENT DC RESTORER	3-10
SECTION 2—OPERATING INFORMATION		LOW-VOLTAGE POWER SUPPLY	3-10
AMBIENT TEMPERATURE CONSIDERATIONS	2-1	POWER INPUT	3-11
CONTROLS AND CONNECTORS	2-1	RECTIFIER AND FILTER	3-11
DETAILED OPERATING INFORMATION	2-1	+18 VOLT UNREGULATED SUPPLY	3-11
SIGNAL CONNECTORS	2-1	-18 VOLT UNREGULATED SUPPLY	3-11
INPUT SIGNAL REQUIREMENTS	2-1	+15 VOLT REGULATED SUPPLY	3-11
CHECKOUT PROCEDURE	2-4	-15 VOLT REGULATED SUPPLY	3-11
TEST EQUIPMENT REQUIRED	2-4	INTERCONNECTIONS	3-11
PRELIMINARY SET UP	2-4		
DISPLAY FUNCTIONS	2-5	SECTION 4—MAINTENANCE	
DEFLECTION AND Z-AXIS FUNCTIONS	2-5	PREVENTIVE MAINTENANCE	4-1
SECTION 3—THEORY OF OPERATION		VISUAL INSPECTION	4-1
BLOCK DIAGRAM	3-1	CLEANING	4-1
DETAILED CIRCUIT OPERATION	3-1	EXTERIOR	4-1
HORIZONTAL (X) AMPLIFIER	3-1	CRT	4-1
X INPUTS	3-1	INTERIOR	4-1
X PREAMPLIFIER	3-3	SEMICONDUCTOR CHECKS	4-1
SCAN LIMITER	3-3	PERIODIC ELECTRICAL ADJUSTMENT	4-1
X FOCUS-CORRECTION PICKOFF	3-3	TROUBLESHOOTING	4-2
X OUTPUT AMPLIFIER	3-3	TROUBLESHOOTING AIDS	4-2
VERTICAL (Y) AMPLIFIER	3-4	DIAGRAMS	4-2
Y INPUTS	3-4	CIRCUIT BOARD ILLUSTRATIONS	4-2
Y PREAMPLIFIER	3-4	TROUBLESHOOTING CHART	4-2
SCAN LIMITER	3-4	TEST POINT AND ADJUSTMENT	
Y FOCUS-CORRECTION PICKOFF	3-4	LOCATIONS	4-2
Y OUTPUT AMPLIFIER	3-4	COMPONENT COLOR CODING	4-2
Z-AXIS AMPLIFIER	3-5	SEMICONDUCTOR LEAD CONFIGURATIONS	4-2
Z INPUTS	3-5	MULTI-PIN CONNECTOR HOLDERS	4-2
Z PREAMPLIFIER	3-5	TROUBLESHOOTING EQUIPMENT	4-5
LIMITER	3-5	TROUBLESHOOTING TECHNIQUES	4-5
Z FOCUS-CORRECTION PICKOFF	3-5	1. CHECK CONTROL SETTINGS	4-5
Z OUTPUT AMPLIFIER	3-5	2. CHECK ASSOCIATED EQUIPMENT	4-5
TTL BLANKING	3-5	3. VISUAL CHECK	4-5
		4. CHECK INSTRUMENT ADJUSTMENT	4-6

TABLE OF CONTENTS (CONT)

	PAGE		PAGE
5. ISOLATE TROUBLE TO A CIRCUIT	4-6	PART II—ADJUSTMENT AND PERFORMANCE	
6. CHECK VOLTAGES AND WAVEFORMS	4-6	CHECK	5-28
7. CHECK INDIVIDUAL COMPONENTS	4-6	INDEX TO PART II—ADJUSTMENT AND	
8. REPAIR AND READJUST THE CIRCUIT	4-7	PERFORMANCE CHECK	5-28
CORRECTIVE MAINTENANCE	4-7	ADJUSTMENT AND PERFORMANCE CHECK	
OBTAINING REPLACEMENT PARTS	4-7	POWER-UP SEQUENCE	5-29
SOLDERING TECHNIQUES	4-7	A. POWER SUPPLIES	5-30
COMPONENT REMOVAL AND REPLACEMENT	4-8	B. CRT	5-33
CATHODE-RAY TUBE REPLACEMENT	4-8	C. HORIZONTAL (X) AMPLIFIER	5-35
CIRCUIT BOARD REPLACEMENT	4-10	D. VERTICAL (Y) AMPLIFIER	5-41
SEMICONDUCTORS	4-15	E. Z-AXIS AMPLIFIER	5-47
INTERCONNECTING CIRCUIT-BOARD		F. DYNAMIC FOCUS	5-51
PIN REPLACEMENT	4-15		
END-LEAD PIN CONNECTORS	4-15		
SECTION 5—CALIBRATION		SECTION 6—INSTRUMENT OPTIONS	
USING THESE PROCEDURES	5-2		
PERFORMANCE CHECK SUMMARY	5-2	SECTION 7—REPLACEABLE ELECTRICAL PARTS	
ADJUSTMENT INTERVAL	5-8		
TEKTRONIX FIELD SERVICE	5-8	SECTION 8—DIAGRAMS AND CIRCUIT BOARD	
TEST EQUIPMENT REQUIRED	5-8	ILLUSTRATIONS	
SPECIAL FIXTURES	5-9		
TEST EQUIPMENT ALTERNATIVES	5-9	SECTION 9—REPLACEABLE MECHANICAL PARTS	
PART I—PERFORMANCE CHECK	5-12		
INDEX TO PART I—PERFORMANCE CHECK	5-12	CHANGE INFORMATION	
PERFORMANCE CHECK POWER-UP SEQUENCE	5-12		
A. POWER SUPPLIES	5-13		
B. CRT	5-14		
C. HORIZONTAL (X) AMPLIFIER	5-15		
D. VERTICAL (Y) AMPLIFIER	5-19		
E. Z-AXIS AMPLIFIER	5-23		
F. DYNAMIC FOCUS	5-26		

GET OF TABLE

The following information is provided for your reference. It is not intended to be used as a substitute for the instructions in this manual. The information is provided for your reference only. It is not intended to be used as a substitute for the instructions in this manual. The information is provided for your reference only. It is not intended to be used as a substitute for the instructions in this manual.

LIST OF ILLUSTRATIONS

FIGURE NO.	PAGE	FIGURE NO.	PAGE
	606B Features		vi
1-4	Location of line-voltage selector plugs, regulating-range pins and fuses		1-4
1-2	Installing and removing a rackmounted instrument		1-6
1-3	606B Dimensional Drawing		1-13
2-1	Front panel controls and indicators (Option 07 Position, FOCUS and INTENSITY controls are screwdriver adjustable)		2-2
2-2	606B Rear panel controls and connectors		2-3
2-3	Alternate input connector data		2-4
3-1	606B Monitor Block Diagram		3-2
3-2	Simplified illustration of geometric defocusing		3-6
4-1	Color code for resistors and capacitors		4-3
4-2	Semiconductor lead configuration		4-4
4-3	Orientation of multi-pin connector holders		4-5
4-4	Crt removal		4-9
4-5	A1 X-Y Output Amplifier board removal		4-10
4-6	A2 X-Y Pre-Amplifier board removal		4-11
4-7	A3 Low Voltage Power and Z-Axis board removal		4-12
4-8	A4 Converter board removal		4-13
4-9	A5 High Voltage board removal		4-13
4-10	A6 Dynamic Focus and Front Panel Control board removal		4-14
4-11	Exploded view of circuit board pin and ferrule		4-15
5-1	Typical crt display for horizontal settling time measurement	5-3	5-16
5-2	Typical crt display for vertical settling time measurement		5-20
		5-4	5-38
		5-5	5-44
			5-54
The illustrations in section 8 are located near their associated diagrams on the foldout page.			
		8-1	Semiconductor Lead Configurations.
		8-2	606B Board Locator.
		8-3	A1-X-Y Output Amplifier circuit board assembly.
		8-4	A2-X-Y Preamplifier circuit board assembly.
		8-5	A1-X-Y Output Amplifier circuit board assembly.
		8-6	A2-X-Y Preamplifier circuit board assembly.
		8-7	A3-Low-Voltage Power & Z-Axis circuit board assembly.
		8-8	A6-Dynamic Focus & Front Panel Control circuit board assembly.
		8-9	A4-Converter circuit board assembly.
		8-10	A5-High-Voltage circuit board assembly.
		8-11	A3-Low-Voltage Power & Z-Axis circuit board assembly.
		8-12	A6-Dynamic Focus & Front Panel Control circuit board assembly.
		8-13	Test Point and Adjustment Locations A.
		8-14	Test Point and Adjustment Locations B.
		8-15	Internal Control and Selector Locations.
		8-16	Troubleshooting Chart.
		8-17	Detailed Dimensional Drawing.

LIST OF TABLES

TABLE NO.	PAGE
1-1	Power-Cord Conductor Identification
1-2	Location of Power-Cord Configuration Information
1-3	Electrical Characteristics
1-4	Environmental Characteristics
1-5	Physical Characteristics
4-1	Low-Voltage Supply Limits
5-1	Calibration Procedure Electives
5-2	Performance Check Summary
5-3	Test Equipment
5-4	Low-Voltage Supply Limits
6-1	Option Information Locator

SAFETY SUMMARY

The general safety information contained in this summary is for servicing personnel. Specific warnings and cautions will be found throughout the manual where they apply, but may not appear in this summary.

TERMS

IN THIS MANUAL

CAUTION statements identify conditions or practices that could result in damage to the equipment or other property.

WARNING statements identify conditions or practices that could result in personal injury or loss of life.

AS MARKED ON EQUIPMENT

CAUTION indicates a personal injury hazard not immediately accessible as one reads the marking, or a hazard to property including the equipment itself.

DANGER indicates a personal injury hazard immediately accessible as one reads the marking.

SYMBOLS

IN THIS MANUAL



Static-Sensitive Devices.



This symbol indicates where applicable cautionary or other information is to be found.

AS MARKED ON EQUIPMENT



DANGER—High voltage.



Protective ground (earth) terminal.



ATTENTION—refer to manual.

WARNINGS

POWER SOURCE

This product is intended to operate from a power source that will not apply more than 250 volts rms between the supply conductors or between either supply conductor and ground. A protective ground connection by way of the grounding conductor in the power cord is essential for safe operation.

GROUNDING THE PRODUCT

This product is grounded through the grounding conductor of the power cord. To avoid electrical shock, plug the power cord into a properly wired receptacle before connecting to the product input or output terminals. A protective ground connection by way of the grounding conductor in the power cord is essential for safe operation.

USE THE PROPER POWER CORD

Use only the power cord and connector specified for your product. Use only a power cord that is in good condition.

For detailed information on power cords and connectors, see the Operating Power Information in Section 1, General Information.

DANGER ARISING FROM LOSS OF GROUND

Upon loss of the protective-ground connection, all accessible conductive parts (including knobs and controls that may appear to be insulating), can render an electric shock.

USE THE PROPER FUSE

To avoid fire hazard, use only the fuse specified in the parts list for your product, and which is identical in type, voltage rating, and current rating.

DO NOT OPERATE IN EXPLOSIVE ATMOSPHERES

To avoid explosion, do not operate this product in an atmosphere of explosive gases unless it has been specifically certified for such operation.

DO NOT SERVICE ALONE

Do not perform internal service or adjustment of this product unless another person capable of rendering first aid and resuscitation is present.

USE CARE WHEN SERVICING WITH POWER ON

Dangerous voltages exist at several points in this product. To avoid personal injury, do not touch exposed connections and components while power is on.

Disconnect power before removing protective panels, soldering, or replacing components.

CRT HANDLING

Use care when handling a crt. Breakage of the crt causes a high-velocity scattering of glass fragments (implosion). Protective clothing and safety glasses should be worn. Avoid striking the crt on any object which might cause it to crack or implode. When storing a crt, place it in a protective carton or set it face down in a protected location on a smooth surface with a soft mat under the faceplate.

CRT IMPLOSION SHIELD

Do not operate the instrument without the proper implosion shield installed.

SILICONE GREASE HANDLING

Handle silicone grease with care. Avoid getting the silicone grease in your eyes. Wash hands thoroughly after use.

SEMIKAWA

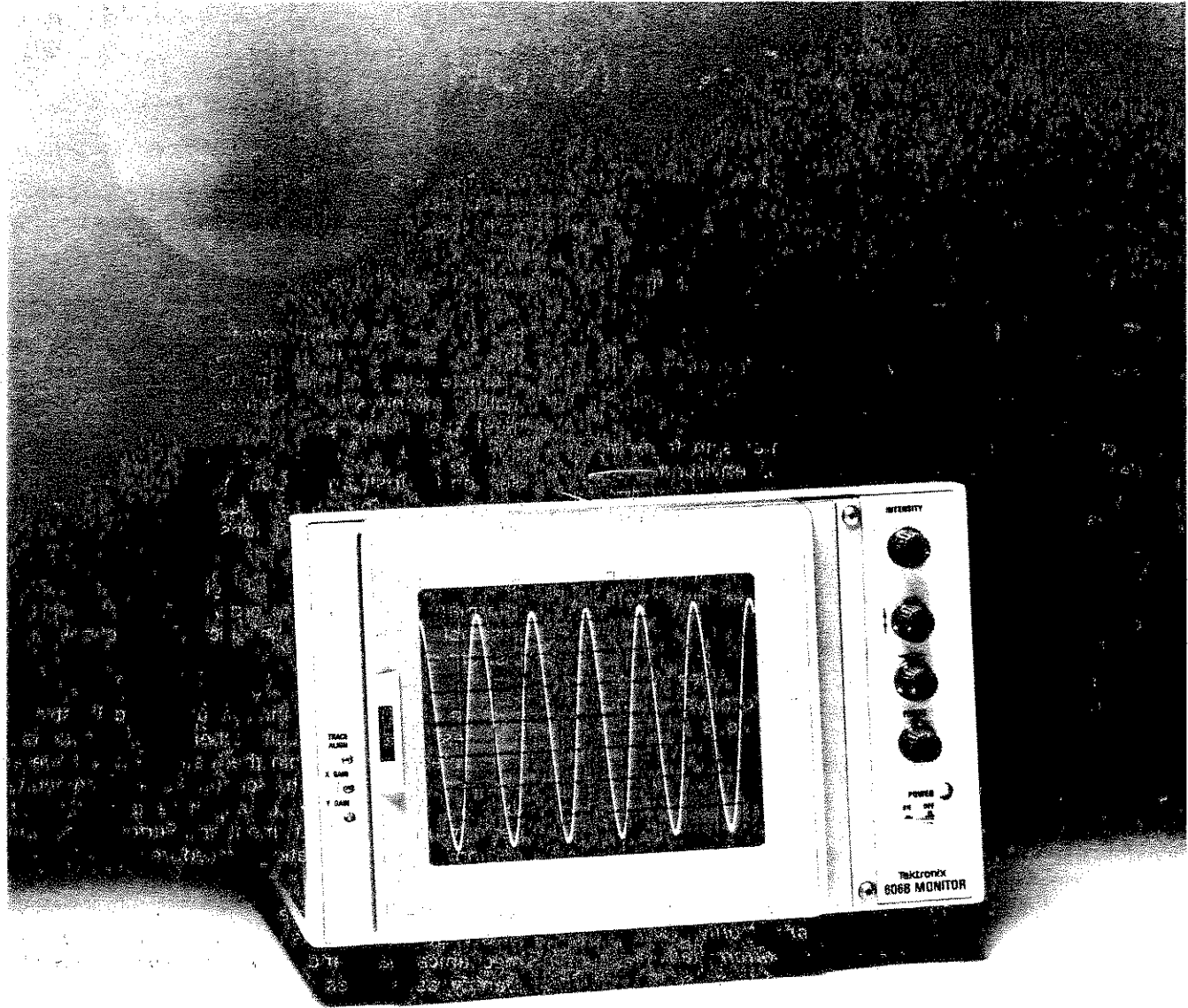

Resolution
606B
features
monitor

606B MONITOR

and
features
to the
product

2821-1

606B FEATURES

The 606B Monitor is a general purpose, very high-resolution, X-Y display monitor providing a clear, bright display of analog data. This instrument is designed for display applications as in ultrasonic detection systems, electronic microscope systems, radiation and thermal scanning systems, speech therapy, volume and vibration analysis, and medical and biophysical systems. The 606B Monitor may also be used to provide displays of alpha-numeric and graphic information from computers and other data transmission systems. Resolution of the crt in this instrument is excellent (shown with Option 6 installed).

GENERAL INFORMATION

This section contains a basic content description of both the Operators and Service Manuals, instrument functional description, rackmounting information, exterior cleaning, instrument packaging, and specifications. The Specification portion consists of three tables; Electrical, Environmental, and Physical Characteristics.

A Standard Accessories list and full-page instrument Dimensional Drawing is also contained in this section.

OPERATORS MANUAL

The Operators Manual is divided into the following three sections:

Section 1—General Information contains instrument description, electrical specifications, environmental characteristics, standard and recommended accessories, and packaging for shipment instructions.

Section 2—Operating Instructions contain information relative to operating and checking the instrument operation.

Section 3—Instrument Options contains a description of available options and gives the location of the incorporated information for those options.

Section 5—Calibration contains procedures to check the operational performance and electrical characteristics of the instrument. Procedures also include methods for adjustment of the instrument to meet specifications.

Section 6—Instrument Options contains a description of available options and locations of incorporated information for those options.

Section 7—Replaceable Electrical Parts contains information necessary to order replaceable parts and assemblies related to the electrical functions of the instrument.

Section 8—Diagrams and Circuit Board Illustrations includes detailed circuit schematics, locations of assembled boards within the instrument, voltage and waveform information, circuit board component locators, and locations of adjustments to aid in the performing of the Adjustment and Performance Check portion of the Calibration procedure.

SERVICE MANUAL

WARNING

The Service Manual contains instructions for use by qualified service personnel only. To avoid personal injury, do not perform any servicing unless you are qualified to do so.

Section 9—Replaceable Mechanical Parts includes information necessary to order replaceable mechanical parts and shows exploded drawings which identify assemblies.

Section 1—General Information contains instrument description, electrical specifications, environmental characteristics, standard and recommended accessories, installation, and packaging for shipment instructions.

Section 2—Operating Instructions contains information on instrument installation, front and rear-panel controls, connectors and indicators, internal switches and selectors, checkout procedure and other information relative to operating and checking instrument operation.

Section 3—Theory of Operation contains basic and general circuit analysis that may be useful for servicing or operating the instrument.

Section 4—Maintenance describes routine and corrective maintenance procedures with detailed instructions for replacing assemblies, subassemblies, and individual components.

INSTRUMENT DESCRIPTION

The 606B Monitor is a compact, solid-state instrument with excellent resolution providing accurate displays of information from the X, Y, and Z signal inputs.

WARNING

High voltage is present inside the instrument. To avoid electric shock hazards, operating personnel must not remove protective instrument covers. Component replacement and internal adjustments must be made by qualified service personnel only.

General Information—606B

The Horizontal (X) and Vertical (Y) Amplifiers process the input signals (either single-ended or differential) and provide push-pull outputs to drive the crt deflection plates. The input signals are applied through the appropriate + (noninverting) and - (inverting) INPUT connectors.

The Z-Axis Amplifier controls the display intensity by providing a voltage to drive the crt control grid. The input signals (either single-ended or differential) are applied through the appropriate + (noninverting) and - (inverting) INPUT connectors.

The High-Voltage and Low-Voltage Power Supplies provide all the voltages necessary for operation of this instrument.

INSTALLATION

INITIAL INSPECTION

This instrument was inspected both mechanically and electrically before shipment. It should be free of marks or scratches and should meet or exceed all electrical specifications. To confirm this, inspect the instrument for physical damage incurred in transit and test the electrical performance by following the Checkout Procedure in Section 2, Operating Instructions. Verify performance requirements by referring a qualified service person to the servicing sections of the Service Manual. If there is damage or deficiency, contact your local Tektronix Field Office or representative.

OPERATING POWER INFORMATION

This instrument can be operated from either a 120-volt or 220-volt nominal line-voltage source, 48 to 440 hertz. In addition, three regulating ranges are provided for each nominal line-voltage source.

CAUTION

To prevent damage to the instrument, always check the line-voltage information recorded on the rear panel before applying power to the instrument.

Power Cord Information

WARNING

This instrument is intended to be operated from a single-phase earth-referenced power source having one current-carrying conductor (the Neutral Conductor) near earth potential. Operation from power sources where both current-carrying conductors are live with respect to earth (such as phase-to-phase on a three-wire system) is not recommended, since only the line conductor has over-current (fuse) protection within the instrument.

This instrument has a three-wire power cord with a polarized two-pole, three-terminal plug for connection to the power source and safety-earth. The safety-earth terminal of the plug is directly connected to the instrument frame. For electric-shock protection, insert this plug only in a mating outlet with a safety-earth contact.

Do not defeat the grounding connection. Any interruption of the grounding connection can create an electric-shock hazard. Before making external connections to this instrument, always ground the instrument first by connecting the power cord to a properly mated power outlet.

TABLE 1-1
Power-Cord Conductor Identification

Conductor	Color	Alternate Color
Ungrounded (Line)	Brown	Black
Grounded (Neutral)	Light Blue	White
Grounding (Earthing)	Green/Yellow	Green/Yellow

The power-cord plug required depends upon the ac input voltage and the country in which the instrument is to be used. Should you require a power-cord plug other than that supplied with your instrument, refer to the standards listed in Table 1-2.

TABLE 1-2
Location of Power-Cord Configuration Information

Nominal Line Voltage	Reference Standards
120 V AC	¹ ANSI C73.11
	² NEMA 5-15P (Hospital Grade)
220 V AC	ANSI C73.20
	³ AS C112
	⁴ BS 1363
	⁵ CEE 7, sheets IV, VI and VII
	NEMA 6-15-P

¹ANSI—American National Standard Institute

²NEMA—National Electrical Manufacturer's Association

³AS—Standards Association of Australia

⁴BS—British Standards Institution

⁵CEE—International Commission on Rules for the Approval of Electrical Equipment

For medical-dental applications, use NEMA 5-15-P (Hospital Grade) plug for 120-volt operation, or NEMA 6-15-P plug for 220-volt operation.

Line-Voltage and Regulating-Range Selection

CAUTION

Damage to the instrument may result from incorrect placement of the line-voltage selector plug. (See Ambient Temperature Considerations, page 2-1.)

To select the correct nominal line voltage and regulating range, proceed as follows:

1. Disconnect the instrument from the power source.
2. Insert the proper line-voltage selector plug (the brown plug for 120-volt operation or the red plug for 220-volt operation) on the line-voltage selector pins (located on the Low-Voltage Power & Z Axis board) labeled for the desired nominal line-voltage range. Refer to Figure 1-1 for location and additional information.
3. Remove the line fuse from the fuse holder and check for the correct rating. Replace it with one having the correct rating, if necessary. Refer to Figure 1-1 for fuse information and location.

NOTE

An alternate line fuse, intended for the line-voltage source for which the Monitor was not set when shipped from the factory, is clipped to the Low-Voltage Power & Z Axis board (see Fig. 1-1).

4. Change the voltage range indicating screw to the appropriate hole in the line-voltage information chart on the 606B rear panel.

5. Apply power to the Monitor.

INSTALLATION IN PATIENT-CARE FACILITIES

WARNING

Do not use the amplifier INPUTS for direct-patient connection. Signal currents at these connectors, as well as leakage currents, may exceed values considered nonhazardous for direct-patient connection.

Although this Monitor is not to be connected directly to a patient, interconnecting this Monitor to other equipment can result in the application of excessive current to a patient. It is extremely important that the interconnection is made in accordance with NFPA 76B-5, Tentative Standard for the Safe Use of Electricity in Patient Care Areas of Health Care Facilities, section 3038, "Signal Transmission Between Appliances".

Among the situations involving the above-mentioned patient hazard is one in which two or more pieces of interconnected equipment are grounded at locations remote from one another. The standard mentioned in the preceding warning describes both this hazard and the appropriate corrective measures.

INPUT ATTENUATION

The Horizontal (X) and Vertical (Y) Amplifiers include selectable 1X/5X step attenuators in both the + (non-inverting) and the - (inverting) input circuits. These attenuators extend the deflection factor range of the appropriate amplifier to at least 12.5 volts for 8 cm signal deflection. Refer to the Internal Control and Selector Locations foldout page in Section 8, Diagrams and Circuit Board Illustrations for the position settings and locations of the attenuator switches. To maintain proper differential operation of the amplifier, always change both the + and - attenuators to the same settings. These step attenuators are set in the 1X position when shipped from the factory.

NOTE

Settling Time specifications (Table 1-1, General Information) are guaranteed only when using the 1X attenuator position.

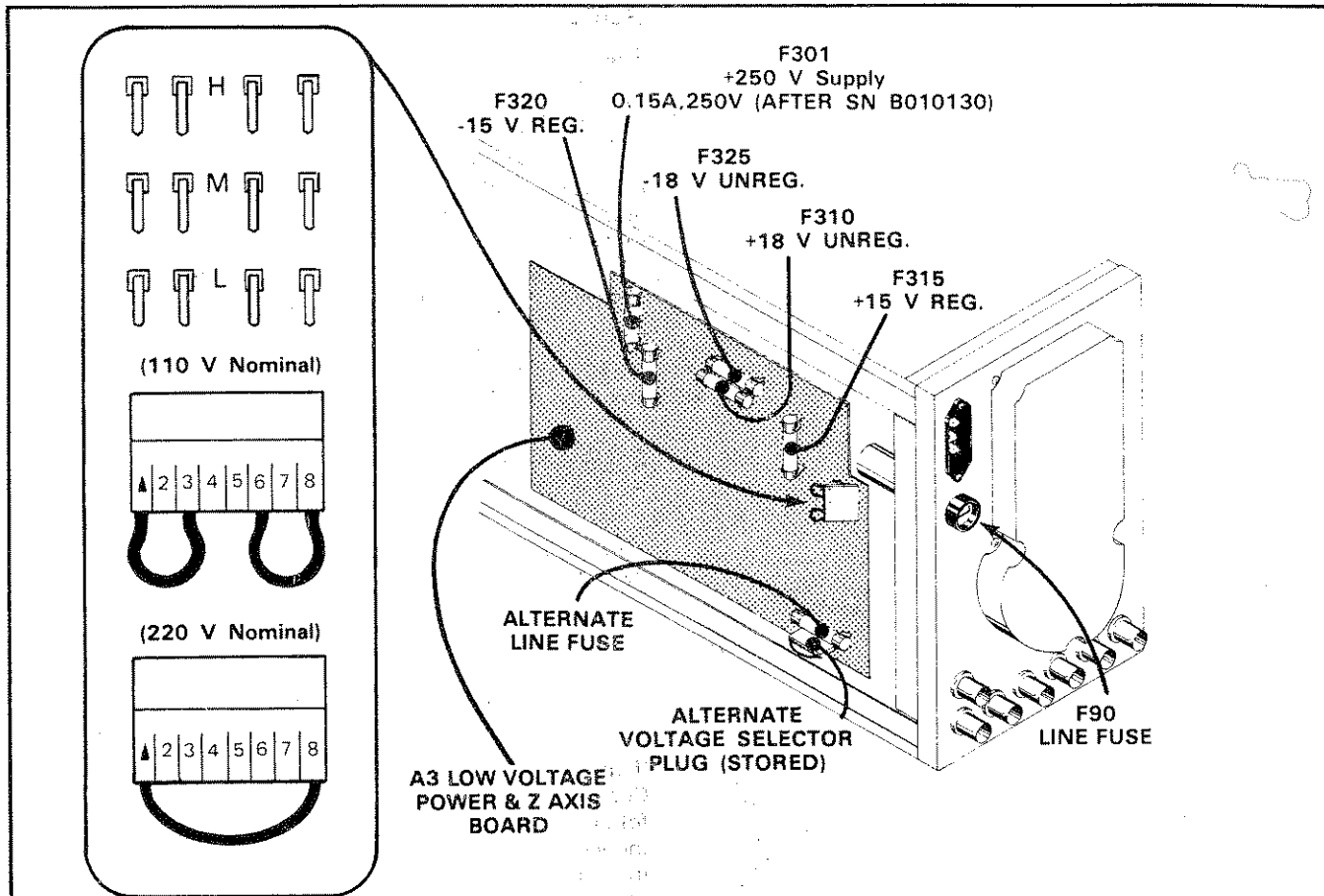

Regulating Range Data		
Line-Voltage Selector Position	110 Volts (Nominal)	220 Volts (Nominal)
L (LOW)	90 to 110 V ac	180 to 220 V ac
M (MED)	99 to 121 V ac	198 to 242 V ac
H (HIGH)	108 to 132 V ac	216 to 250 V ac

Fuse Data	
Supply	Description
Line	1.2 A (110 V Nominal) 0.6 A (220 V Nominal) slow
+18 v dc Unregulated	1.5 A 250 V fast blow
-18 V dc Unregulated	1.5 A 250 V fast blow
+15 V dc Regulated	0.5 A 250 V fast blow
-15 V dc Regulated	0.5 A 250 V fast blow
+250 V dc Regulated	0.15 A 250 V fast blow

2821-6A

Figure 1-1. Location of line-voltage selector plugs, regulating-range pins and fuses.

INPUT IMPEDANCE

The X, Y, and Z-Axis amplifiers of the 606B Monitor are shipped from the factory with an input impedance of 50 Ω . Jumpers are provided on the X-Y Pre-Amplifier board (for the X and Y amplifiers) and on the Low Voltage Power and Z-Axis board (for the Z-Axis amplifier) to facilitate changing the input impedance from the factory set impedance (50 Ω) to 1 M Ω .

Refer to Internal Control and Selector Locations foldout page in Section 8, Diagrams and Circuit Board Illustrations for locations and positions.

RACKMOUNTING INFORMATION

The 606B can be operated in a standard 19-inch instrument rack with front and rear holes that conform to universal hole spacing. Kits are available to convert the 606B from the cabinet to a rackmounted configuration, and vice versa. Complete instructions are included in the kits. A brief description of each available conversion kit is given here. Consult your Tektronix Field Office or representative for additional information.

CAUTION

Reliability and performance of the 606B will be affected if the ventilation holes in the protective panels are obstructed. Forced ventilation methods will be needed if the 606B is operated at an ambient temperature higher than +50°C (see Ambient Temperature Considerations in Section 2 of this manual).

CABINET-TO-RACKMOUNT CONVERSION

Tektronix Part 040-0600-XX. Mounts two 606B Monitors side-by-side in a standard 19-inch wide rack. The kit comes equipped with a slide-out assembly and includes the securing hardware. Complete rackmounting instructions are included in each kit.

Tektronix Part 040-0601-XX. Mounts 606B Monitor in a standard 19-inch wide rack. The kit is equipped with a slide-out assembly, securing hardware, and a blank front panel to cover the second instrument opening in the rack. Complete rackmounting instructions are included in each kit.

Tektronix Part 040-0624-XX. Converts one TM-503 Power Module and one 606B Monitor to mount side-by-side in a standard 19-inch wide instrument rack. The kit includes slide-out assembly and securing hardware. Complete rackmounting instructions are included with each kit.

RACKMOUNT-TO-CABINET CONVERSION

Tektronix Part 040-0602-XX. Converts one 606B Monitor from a rackmount configuration to a cabinet configuration. Complete instructions are included in each kit.

SLIDE-OUT TRACKS

The slide-out tracks provided in the conversion kits support the monitor in their fully extended position. This allows access to the instrument for maintenance without removing it from the rack. Be sure the power cord and signal cables are long enough to allow operation in the extended position. Refer to the instructions in the appropriate rackmount kit for information on track installation and adjustment.

REMOVING OR INSTALLING THE INSTRUMENT

The instrument can be installed or removed by following the instructions given in Figure 1-2. No further adjustments are required under normal conditions.

SLIDE-OUT TRACK LUBRICATION

The special finish on the sliding surfaces of the tracks provides permanent lubrication. However, if the tracks require additional lubrication, a thin coat of paraffin can be rubbed onto the sliding surfaces.

INSTRUMENT PACKAGING

If the instrument is to be shipped to a Tektronix Service Center for service or repair, attach a tag showing the following: Owner (with address) and the name of an individual at your firm who can be contacted, complete instrument type and serial number, and description of the service required.

Save and reuse the package in which your 606B Monitor was shipped to you. If the original packaging is unfit for use or is not available, repackage the instrument as follows:

1. Obtain a corrugated cardboard carton with a 275 pound test strength, and having inside dimensions of no less than six inches more than the instrument dimensions; this allows for cushioning.
2. Surround the instrument with polyethylene sheeting to protect the finish.
3. Surround the instrument frame with heavy cardboard (if no protective cabinet panels are available) to minimize the danger of component damage by the packing material.
4. Cushion the instrument on all sides by tightly packaging dunnage or urethane foam between the carton and the instrument, allowing three inches on all sides.
5. Seal the carton with shipping tape or with an industrial stapler.
6. Mark the address of the Tektronix Service Center and your return address on the carton in one or more prominent locations.

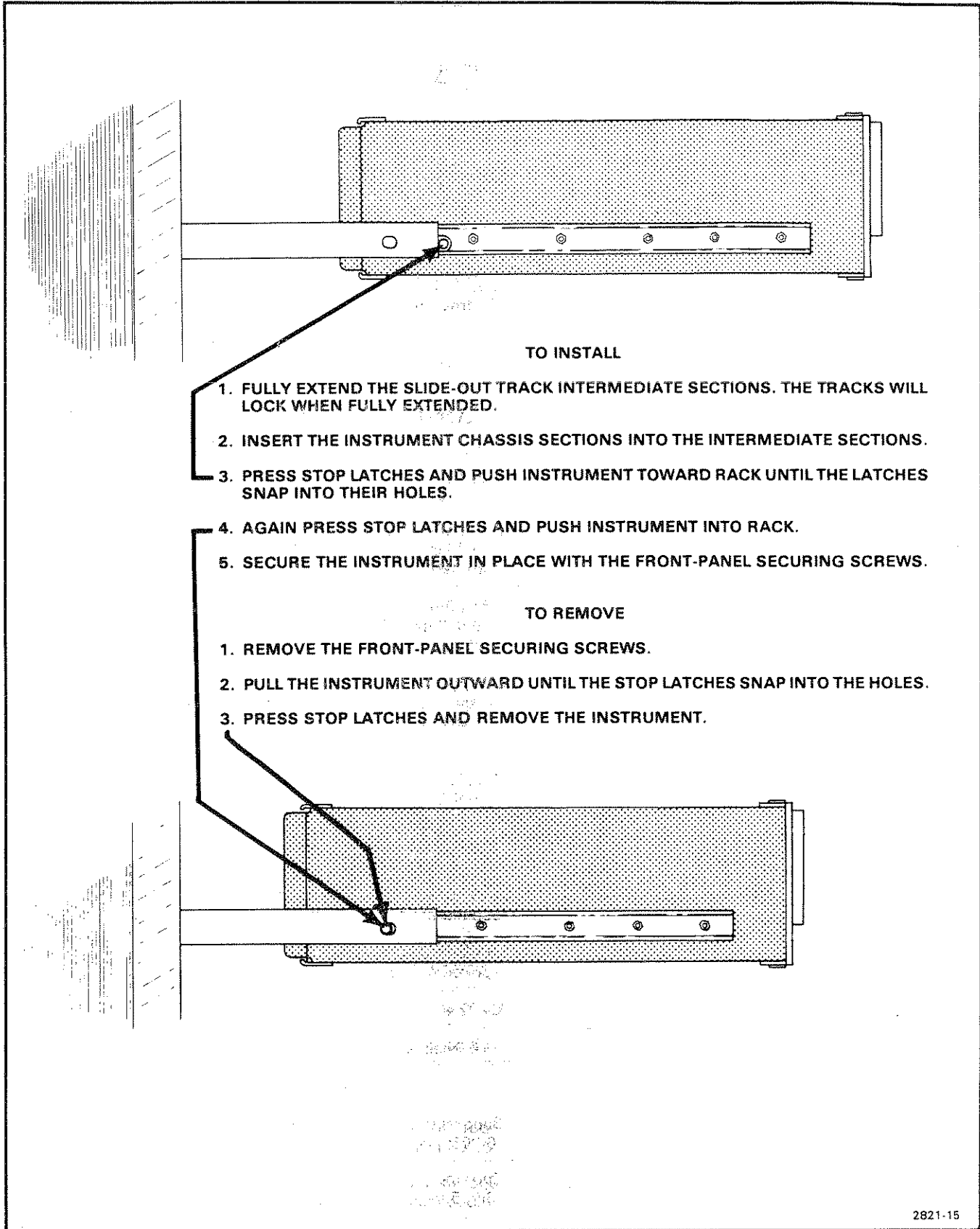

2821-15

Figure 1-2. Installing and removing a rackmounted instrument.

SPECIFICATION

The electrical specifications listed in Table 1-3 apply when the following conditions are met: (1) The instrument must have been adjusted at an ambient temperature between +15° and +25° C, (2) The instrument must be operating in an ambient temperature between 0° and +50° C and (3) The instrument must have been operating for at least 20 minutes.

TABLE 1-3
Electrical Characteristics

Characteristic	Performance Requirement
VERTICAL AND HORIZONTAL AMPLIFIERS	
Deflection Factor	
Vertical	Internally adjustable from 0.5 volt to 2.5 volts for 8 divisions of deflection. Externally adjustable for at least $\pm 10\%$ of nominal.
Horizontal	Internally adjustable from 0.5 volt to 2.5 volts for 8 divisions of deflection. Externally adjustable for at least $\pm 10\%$ of nominal.
Attenuators	Internal 1X-5X step attenuators extend the deflection factor range to at least 12.5 volts full screen.
Polarity	
+X INPUT	Positive signal applied deflects beam to the right; negative signal applied deflects beam to the left.
-X INPUT	Positive signal applied deflects beam to the left; negative signal applied deflects beam to the right.
+Y INPUT	Positive signal applied deflects beam up; negative signal applied deflects beam down.
-Y INPUT	Positive signal applied deflects beam down; negative signal applied deflects beam up.
Bandwidth (80% full screen reference signal)	Dc to at least 3 MHz at -3 dB point.
Risetime	116 nsec or less.
Settling time (input attenuators in 1X position)	
After deflection between any two points on screen	Spot must reach new writing position, within 0.012 cm (0.005 inch), within 500 ns.
After deflection to any point on screen from within 10 cm of screen center.	Spot must reach new writing position, within 0.012 cm (0.005 inch), within 700 ns.
Phase Difference (Dc to 500 kHz)	1 degree or less between X and Y amplifiers. X and Y amplifier gain must be set for the same deflection factor (Volts/Div).

TABLE 1-3 (CONT)
Electrical Characteristics

Characteristic	Performance Requirement
Common-Mode Rejection	
Attenuator 1X (± 3 volts peak input)	
DC to 500 kHz	At least 100:1.
500 kHz to 1 MHz	At least 40:1.
Attenuator 5X (± 15 volts peak input)	
DC to 500 kHz	At least 40:1.
Input Impedance	1 M Ω within 1%, or 50 Ω within 1%; paralleled by 47 pF or less.
Maximum Nondestructive Input Voltage (fault condition only)	
1 M Ω Input Impedance	± 100 V dc + peak ac.
50 Ω Input Impedance	± 5 V dc + peak ac.
Dynamic Range	At least ± 1.5 screen diameters from screen center (± 10 cm).
Position Range	Spot may be positioned anywhere on screen with no signal input.
Position Stability	0.1 cm or less drift per hour after 20 minutes warmup. Less than 0.2 cm drift in 24 hr. with cabinet covers in place. Less than 0.2 cm drift from 0° to 50° C ambient temperature variation, after 20 min. warmup.
Gain Stability	Less than 1% change under all conditions of line voltage and temperature.
Crosstalk	
Between X and Y Amplifiers at 1 MHz	0.005 cm (0.002 inch) or less of deflection on the undriven channel with full screen amplitude of 1 MHz sinewave applied to the other channel. Other inputs grounded or terminated into 50 ohms.
Between Z and X or Y Amplifier	0.012 cm (0.005 inch) or less of deflection on the undriven channels when the Z-Axis Amplifier is driven for a 70 V output with a 1 MHz sinewave. X and Y inputs grounded or terminated into 50 ohms.

Z AXIS AMPLIFIER

Gain Range	internal adjustment allows a 1 volt to 5 volts input to generate the maximum allowable voltage swing at the crt control grid (0 V to ≈ 70 V).
Bandwidth	Dc to 5 MHz at -3 dB point.
Risetime	35 ns or less.
Aberration	5% or less.
Common Mode Rejection	
Dc to 1 MHz	At least 100:1 (± 5 volts peak input).

TABLE 1-3 (CONT)
Electrical Characteristics

Characteristic	Performance Requirement
Input Impedance	1 M Ω within 1%, or 50 Ω within 1%; paralleled by 47 pF or less.
Maximum Nondestructive Input Voltage (fault condition only)	
1 M Ω Input Impedance	± 100 V dc + peak ac.
50 Ω Input Impedance	± 5 V dc + peak ac.
Transfer Curve	Deviation from linear response of light output to voltage input is less than 20% of maximum intensity, between 10% and 100% of maximum intensity.
TTL Input	Logic input blanks or unblanks crt to level set by INTENSITY control and Z INPUT voltage.
HI	+2.4 V to +5 V.
LO	0 V to +0.8 V.
Rise Time	35 ns or less.
Fall Time	35 ns or less.
Stability	Light output varies less than 5% under all conditions of line voltage and temperature, when intensity is set for at least 10% of maximum brightness.

CATHODE RAY TUBE

Display Area	8 \times 10 cm.
Quality Area	7 \times 9 cm.
Geometry (full screen)	Bowing or tilt 1 mm or less.
Orthogonality (full screen)	90 $^\circ$ within 0.7 $^\circ$.
Compression and Expansion	Less than 1% of full screen deflection.
Phosphor	
Standard	P31.
Option 78	P11.
Deflection	Electrostatic.
Spot Diameter (P31 phosphor)	0.079 cm (0.0031 inch) or less, with INTENSITY set for 3.45 μ W/cm 2 , 700 line, 7 \times 9 cm focused raster.
Spot Shape (quality area)	The ratio between two perpendicular spot cross sections does not exceed 1.5:1.
Spot Growth (quality area)	Not greater than 20% at constant intensity.

TABLE 1-3 (CONT)
Electrical Characteristics

Characteristic	Performance Requirement
Grid Drive	Approximately 70 V above the level of visible cutoff. Measured at crt grid.
Acceleration Potential	5.4 kV within 1%.
Light Output (quality area)	Greater than 20 $\mu\text{W}/\text{cm}^2$ using a 700 line 60 Hz refresh raster with a 100% duty cycle. Maximum allowable drive to the crt.
Light Output Uniformity (quality area)	When screen is flooded using raster method and light output is at least 10% of maximum, light output will vary less than 2%/cm and vary less than 10% over the entire quality area.
Defects	The following definitions apply to measuring screen defects: LENGTH: The maximum linear dimension in any direction across the defect in question. WIDTH: The maximum linear dimension perpendicular to the length.
Quality Area	<ol style="list-style-type: none"> 1. Any number of defects less than 5 mils in both width and length. 2. No defects with length plus width exceeding 20 mils except when the width is less than one mil. 3. Any number of defects with width less than one mil. 4. No more than five defects greater than one mil in width, greater than five mils in length, and with length plus width equal to or less than 20 mils. No two such defects can be within one centimeter of each other.
Outside Quality Area	Not more than three holes with length plus width equal to or more than 25 mils.

POWER SOURCE

LO Line Voltage Range	
L (100 V ac)	90 to 110 V ac.
M (110 V ac)	99 to 121 V ac.
H (120 V ac)	108 to 132 V ac.
HI Line Voltage Range	
L (220 V ac)	180 to 220 V ac.
M (220 V ac)	198 to 242 V ac.
H (240 V ac)	216 to 250 V ac.
Line Frequency	48 to 440 Hz.
Power Consumption	
Maximum	75 W, 120 V ac, 60 Hz.
Nominal	50 W, 120 V ac, 60 Hz.

TABLE 1-3 (CONT)
Electrical Characteristics

Characteristic	Performance Requirement
Fuse Data	
LO Line Voltage	Slow blow, 1.2 Amp.
HI Line Voltage	Slow blow, 0.6 Amp.

POWER SUPPLIES

Supply (dc)	Voltage Range	Ripple (p-p)
-15 V dc	-15.2 V to -14.8 V	2 mV or less
+15 V dc	+14.95 V to +15.05 V	2 mV or less
+95 V dc	+94.0 V to +98.0 V	100 mV or less
+250 V dc	+249 V to +251 V	150 mV or less
-5.4 kV dc	-5.35 kV to -5.45 kV	

TABLE 1-4
Environmental Characteristics

Characteristic	Information
Ventilation	Convection cooling.
Position	Instrument has to be positioned with the bottom or the rear panel down, within 45 degrees.
Temperature (ambient)	
Operating	0° C to +50° C (+32° F to +122° F).
Nonoperating	-40° C to +70° C (-40° F to +158° F).
Altitude	
Operating	To 4.5 km (15,000 ft.).
Nonoperating	To 14.5 km (50,000 ft.).
Vibration	With the instrument complete and operating, vibration frequency swept 10 to 50 to 10 Hz at 1 minute per sweep. Vibrate 15 minutes in each of the 3 major axes at 0.025 inch total displacement. Hold 3 minutes at any major resonance, or if none, at 50 Hz. Total time 54 minutes.

TABLE 1-4 (CONT)
Environmental Characteristics

Characteristic	Information
Shock	50 g, 1/2 sine, 11 ms duration, 2 shocks in each direction along 3 major axes, for a total of 12 shocks.
Transportation	Qualified under National Safe Transit Committee Test Procedure 1A, Category II.
Humidity (Class 5)	Test to MIL-STD-810C method 507.1 procedure IV modified and specified in MIL-T-28800B Par. 4.5.5.1.1.2.
Operating	50° C 90 to 95% R.H.
Nonoperating	60° C 90 to 95% R.H.

TABLE 1-5
Physical Characteristics

Characteristic	Information
Weight	Approximately 17.5 lbs.
Overall dimensions	See 606B Dimensional Drawing, Figure 1-3.

STANDARD ACCESSORIES

- 1 ea Operators Manual
- 1 ea Service Manual
- 1 ea Internal Lined Graticule (8 × 10 division)
- 1 ea Detachable Power Cord
- 1 ea Connector, Receptacle, 25 pin, Male

For more detailed information, refer to the tabbed Accessories page at the rear of this Manual.

2821 2

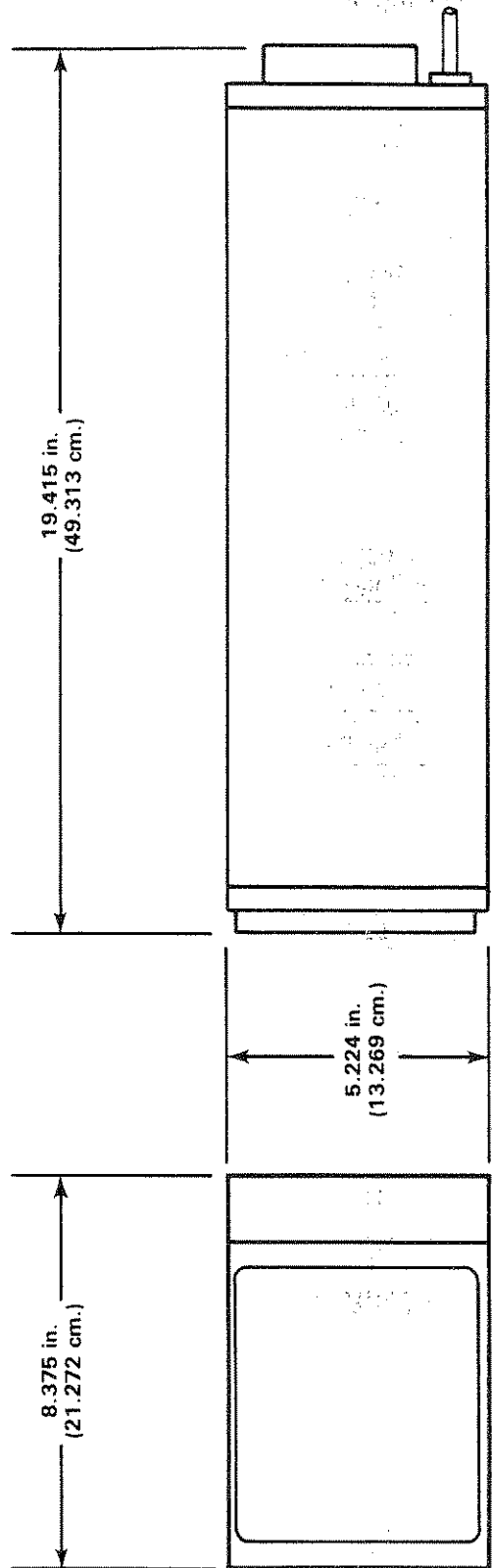

NOTE:
TOP NUMBERS IN INCHES,
BOTTOM NUMBERS IN
CENTIMETERS

Figure 1-3. 606B Dimensional Drawing.

OPERATING INFORMATION

To operate this instrument effectively, the user must become familiar with the operation and capabilities of the instrument. This section contains preliminary operating information, a description of front- and rear-panel controls, connectors, and indicators, and a checkout procedure. Detailed operating information and typical applications are included in this section.

AMBIENT TEMPERATURE CONSIDERATIONS

This instrument can be operated where the ambient air temperature is between 0° and +50° C, and can be stored in ambient temperatures between -40° and +70° C. After being stored in temperatures beyond the operating limits, allow the chassis temperature to return to within the operating limits before applying power. Allowing the Monitor to operate at an ambient temperature substantially higher than that specified may result in poor reliability as well as inaccurate performance.

When the 606B is mounted in a rack with other equipment, do not allow the temperature surrounding the monitor to exceed +50° C. Additional clearance or forced ventilation methods (fan) may be necessary to maintain ambient temperatures below +50° C. The reliability and performance of the 606B will be affected if the ventilation holes in the protective panels are obstructed or if the 606B is operated at an ambient temperature higher than +50° C. Other environments and mounting configurations may require additional cooling measures.

CONTROLS AND CONNECTORS

Controls and connectors necessary for operation of the 606B Monitor are located on the front and rear panels of the instrument. To make full use of the capabilities of the 606B the operator should be familiar with the function and use of each external control and connector. The front-panel controls are shown and described in Figure 2-1. Brief descriptions of the rear-panel controls and connectors are given in Figure 2-2.

DETAILED OPERATING INFORMATION

SIGNAL CONNECTORS

The bnc connectors on the rear panel of the standard 606B Monitor are provided for application of input signals to the vertical (Y) and horizontal (X) Amplifiers for display on the crt, and to the Z-Axis Amplifier to control the display intensity. An additional bnc connector is provided to allow application of TTL-compatible input voltages to blank the display.

The 606B Monitor also provides a 25-pin male Cannon connector located on the rear panel for direct connections to the X, Y and Z-Axis Amplifiers and the Dynamic Focus. Signal requirements are the same as for the bnc inputs. See Figure 2-3 for pin assignments.

NOTE

The bnc grounding caps will short the equivalent input from the ALTERNATE INPUTS connector. Be sure the grounding cap is on the -INPUT before making connection to the ALTERNATE INPUTS connector.

INPUT SIGNAL REQUIREMENTS

The horizontal (X) and vertical (Y) deflection factors are set at the factory to one volt for eight divisions of deflection on each axis. Thus, as shipped, the input signal required for each division of deflection is 0.125 volt.

The best transient response from the 606B Monitor is achieved when the input signal amplitude to the X and Y INPUT is no greater than that sufficient to provide full-screen deflection.

WARNING

To avoid electric shock hazard, do not apply input signals at more than 25 volts (dc plus peak ac).

With no signals applied to the Z INPUT, the intensity of the display is controlled only by the front-panel INTENSITY control. To control the display intensity with an externally applied signal, set the INTENSITY control to about midrange, and apply the input signal to the Z INPUT connector.

CAUTION

Exercise care in establishing the correct display intensity; a high-amplitude Z-Axis input signal, combined with an excessively high setting of the INTENSITY control, may damage the crt phosphor. The very small spot size of this instrument increases the chances of crt phosphor damage. Do not allow a stationary, bright, focused spot to remain on the screen.

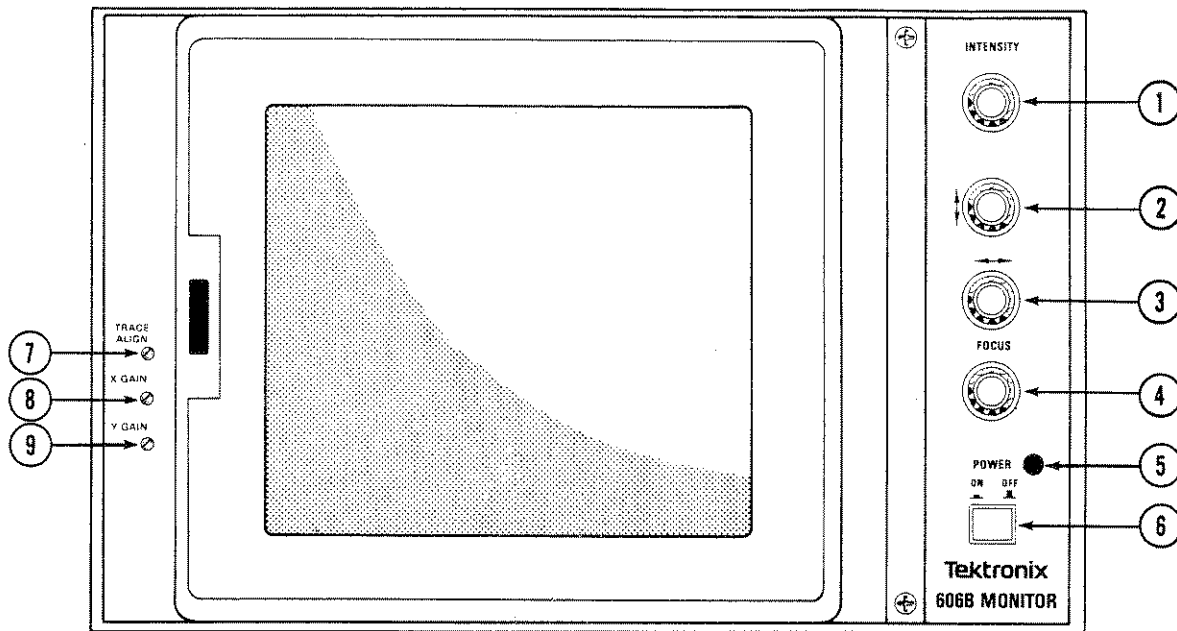

- ① **INTENSITY***— Controls brightness of the crt display.
- ② **Vertical (↑↓)* Position**—Positions the crt beam in the Y-axis.
- ③ **Horizontal (←→)* Position**—Positions the crt beam in the X-axis.
- ④ **FOCUS***—Provides adjustment to obtain a well-defined display.
- ⑤ **POWER (indicator)**—Illuminates when instrument is on.
- ⑥ **ON/OFF**—Controls power to the monitor. Instrument is on when pushbutton is in.
- ⑦ **TRACE ALIGN**—Provides slight beam rotation for alignment in the X-axis.
- ⑧ **X GAIN**—Provides ±10% adjustment of nominal X gain setting.
- ⑨ **Y GAIN**—Provides ±10% adjustment of nominal Y gain setting.

*Option 7—Front panel controls are screwdriver adjust.

2821-3

Figure 2-1. Front panel controls and indicators (Option 7-Position, FOCUS and INTENSITY controls are screwdriver adjustable).

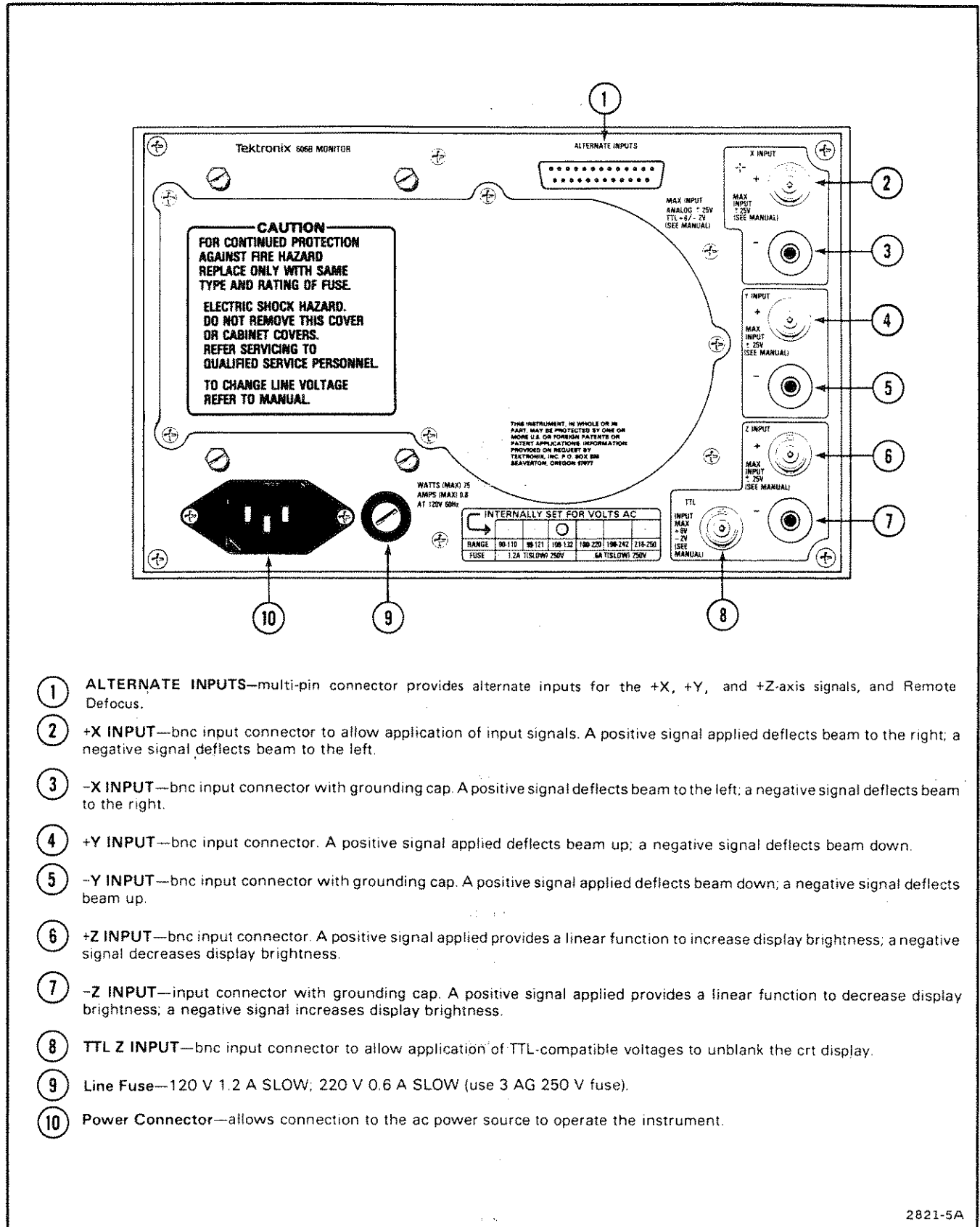

- ① **ALTERNATE INPUTS**—multi-pin connector provides alternate inputs for the +X, +Y, and +Z-axis signals, and Remote Defocus.
- ② **+X INPUT**—bnc input connector to allow application of input signals. A positive signal applied deflects beam to the right; a negative signal deflects beam to the left.
- ③ **-X INPUT**—bnc input connector with grounding cap. A positive signal deflects beam to the left; a negative signal deflects beam to the right.
- ④ **+Y INPUT**—bnc input connector. A positive signal applied deflects beam up; a negative signal deflects beam down.
- ⑤ **-Y INPUT**—bnc input connector with grounding cap. A positive signal applied deflects beam down; a negative signal deflects beam up.
- ⑥ **+Z INPUT**—bnc input connector. A positive signal applied provides a linear function to increase display brightness; a negative signal decreases display brightness.
- ⑦ **-Z INPUT**—input connector with grounding cap. A positive signal applied provides a linear function to decrease display brightness; a negative signal increases display brightness.
- ⑧ **TTL Z INPUT**—bnc input connector to allow application of TTL-compatible voltages to unblank the crt display.
- ⑨ **Line Fuse**—120 V 1.2 A SLOW; 220 V 0.6 A SLOW (use 3 AG 250 V fuse).
- ⑩ **Power Connector**—allows connection to the ac power source to operate the instrument.

2821-5A

Figure 2-2. 606B Rear panel controls and connectors.

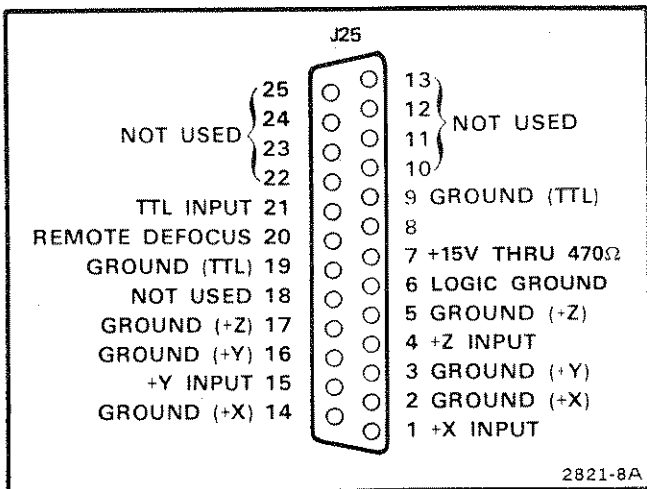

Figure 2-3. Alternate input connector data.

The input signal required for maximum display intensity, through the Z INPUT connector, is set at the factory for approximately +1 volt. The input signal required to visually cut off the display intensity (INTENSITY set at midrange) is set at the factory for approximately -1 volt. The best transient response of the Z-Axis Amplifier is achieved when the input signal is the minimum required to provide the desired intensity change.

An additional bnc connector is provided on the rear panel for application of TTL-compatible input voltages to blank the crt display. The input voltage level necessary to produce blanking is internally selectable. Refer to the Internal Control and Selector Locations foldout in Section 8, Diagrams and Circuit Board Locations, at the rear of the manual.

CHECKOUT PROCEDURE

The Checkout Procedure may be used to verify proper operation of the front-panel controls and for familiarization with the instrument. Only instrument functions (not measurement quantities or specifications) are checked in the procedure; therefore, a minimum amount of test equipment is required. If performing the Checkout Procedure reveals improper performance or instrument malfunction, check the operation of associated equipment; then refer to the Calibration section for repair or adjustment of the instrument.

WARNING

High voltage is present inside the instrument. Use extreme caution to avoid electric-shock hazards whenever the covers are removed.

TEST EQUIPMENT REQUIRED

The following test equipment was used as a basis to write the Checkout procedure. Other test equipment, which meets these requirements, may be substituted. When other equipment is substituted, the control settings or set up may need to be altered.

1. Power Module

Description: TEKTRONIX TM 500-Series Power Module with one or more plug-in compartments.

Type Used: TEKTRONIX TM 501 (used with the FG 503 Function Generator).

2. Function Generator

Description: Frequency range, one hertz to 50 kilohertz; output amplitude, one volt peak-to-peak into 50 ohms, waveform output, sine wave.

Type Used: TEKTRONIX FG 503 Function Generator (used with TM 501 Power Module).

3. Cables bnc (3 required)

Description: Length, 42 inches (1 required), 18 inches (2 required); connectors, bnc.

Type Used: Type RG-58/U, 50-ohm coaxial, Tektronix Part 012-0057-01 (42 inch), Tektronix Part 012-0076-00 (18 inch).

4. T Connector

Description: Connectors, bnc-to-bnc.

Type Used: Bnc-to-bnc T connector, Tektronix Part 103-0030-00.

5. 50-ohm Termination

Description: Impedance, 50 ohm; connectors, bnc.

Type Used: Tektronix Part 011-0049-01.

6. 5X Attenuator

Description: Impedance 50 ohm; connectors, bnc.

Type Used: Tektronix Part 011-0060-02.

PRELIMINARY SET UP

1. Install the function generator in the power module and turn on the power module.
2. Connect the 606B power cord to a compatible power source.

NOTE

Check the line voltage information recorded on the rear panel. If the source voltage is not within this range, refer to the servicing information sections of this Manual.

3. Set the front-panel controls as follows:
 Vertical and Horizontal Position..... midrange
 INTENSITYfully counterclockwise
 FOCUS..... midrange
 ON/OFF ON (pushbutton in)
4. Allow at least one minute for the instrument to warm up.
5. Proceed to the functional check procedure.

DISPLAY FUNCTIONS

1. Perform the Preliminary Set-Up procedure.
2. Notice that a spot will appear on the crt, increasing in brightness as you slowly turn the INTENSITY control clockwise.

NOTE

A high intensity level combined with a stationary spot will damage the crt phosphor. Therefore, set the INTENSITY control to the minimum necessary for good visibility.

3. Adjust the FOCUS control for a sharp, well-defined display. Final focus adjustment must be made with a magnifier or microscope to guarantee resolution.
4. Turn the Vertical and Horizontal Position controls and notice that the spot position can be controlled by both controls.

DEFLECTION AND Z-AXIS FUNCTIONS

1. Perform the Preliminary Set Up procedure.
2. Set the function generator for a 1-volt (peak-to-peak), 50-kilohertz sine-wave output as measured through a 50 ohm terminator.
3. Connect the function generator output to the rear-panel +X INPUT connector via the 42-inch cable and the 50 ohm terminator.
4. Center the display with the horizontal Position control, and check for 8 divisions of horizontal deflection.
5. Remove the grounding cap from the -X INPUT connector.
6. Disconnect the signal from the +X INPUT connector and apply it to the -X INPUT connector through the 50 ohm terminator.
7. Place the grounding cap on the +X INPUT connector.
8. Center the display with the horizontal Position control.

9. Check for 8 divisions of horizontal deflection.
 10. Disconnect the signal from the -X INPUT connector and apply it to the +Y INPUT connector through the 50 ohm terminator.
 11. Center the display on the crt with the vertical Position control.
 12. Check for 8 divisions of vertical deflection.
 13. Remove the grounding cap from the -Y INPUT connector.
 14. Disconnect the signal from the +Y INPUT connector and apply it to the -Y INPUT connector through the 50 ohm terminator.
 15. Place the grounding cap on the +Y INPUT connector.
 16. Center the display on the crt with the vertical Position control.
 17. Check for 8 divisions of vertical deflection.
 18. Adjust the INTENSITY control for a barely-visible display.
 19. Remove the grounding caps from the +X INPUT and the +Z INPUT connectors.
 20. Disconnect the signal from the -Y INPUT connector and apply it to the +X INPUT and the +Z INPUT connectors via the 42-inch cable, bnc-to-bnc adapter, bnc T connector, and the two 18-inch cables. Connect a 5X attenuator between the 18 inch cable and the +Z INPUT.
 21. Place the grounding caps on the -X INPUT and the -Z INPUT connectors.
 22. Notice that the right end of the crt display becomes bright, and that the left end disappears.
 23. Remove the grounding cap from the -Z INPUT connector.
 24. Disconnect the signal from the +Z INPUT connector and apply it to the -Z INPUT connector through the 5X attenuator.
 25. Place the grounding cap on the +Z INPUT connector.
 26. Notice that the left end of the crt display becomes bright, and that the right end disappears.
 27. Disconnect the Function Generator.
- This completes the Checkout Procedure.

THEORY OF OPERATION

This section of the manual describes the circuitry in the 606B Monitor. The description begins with a discussion of the instrument using a block diagram, then continues in detail, showing the relationships between the stages in each major circuit. Schematics of all major circuits are given in Section 8, Diagrams and Circuit Board Illustrations. Stages are outlined on the schematics with wide shaded lines; the stage names are in shaded boxes. Refer to these schematics throughout the following discussions for specific electrical values and relationships.

BLOCK DIAGRAM

The following discussion is provided to aid in understanding the overall concept of the 606B before the individual circuits are discussed in detail. A basic block diagram is shown in Figure 3-1.

The Horizontal (X) and Vertical (Y) Amplifiers process the input signals (either single-ended or differential) and provide push-pull outputs to drive the crt deflection plates. The input signals are applied through the appropriate + (noninverting) and - (inverting) input connectors.

The Z-Axis Amplifier controls the display intensity by providing a voltage to drive the crt control grid. The input signals (either single-ended or differential) are applied through the appropriate + (noninverting) and - (inverting) input connectors or to the ALTERNATE INPUTS connector.

The Dynamic Focus circuit provides focus correction for the display when it is deflected from the crt center. Thus, by varying the voltage to the crt gun elements, the Dynamic Focus circuit compensates for geometric defocusing.

The High-Voltage and Low-Voltage Power Supplies provide all the voltage necessary for operation of this instrument.

DETAILED CIRCUIT OPERATION

Complete schematic diagrams are provided in Section 8, Diagrams and Circuit Board Illustrations. The numbers inside the diamond above a heading in the following discussions refer to the schematic diagram for that circuit. The schematic diagrams contain wide shaded borders around the major stages of the circuits to conveniently locate the components mentioned in the following discussions. The name of each stage is given in a shaded box on the diagram and as sub-headings in the discussion of that schematic diagram.



HORIZONTAL (X) AMPLIFIER

The Horizontal (X) Amplifier processes the X input signals (either single-ended or differential) and provides final amplification to drive the horizontal deflection plates of the crt. A schematic diagram of the Horizontal (X) Amplifier is shown on diagram 1. A detailed block diagram, identifying each major stage of the Horizontal (X) Amplifier, is superimposed on the schematic with wide shaded lines to conveniently locate the components

mentioned here. The stage names (given as sub-headings in the following discussion) can be found in the shaded boxes on diagram 1.

X INPUTS

Three input signal connectors are provided to the X Inputs stage: (1) the +X INPUT (noninverting) bnc connector J10, (2) the -X INPUT (inverting) bnc connector J20 and (3) the ALTERNATE INPUTS (noninverting) cannon connector J25.

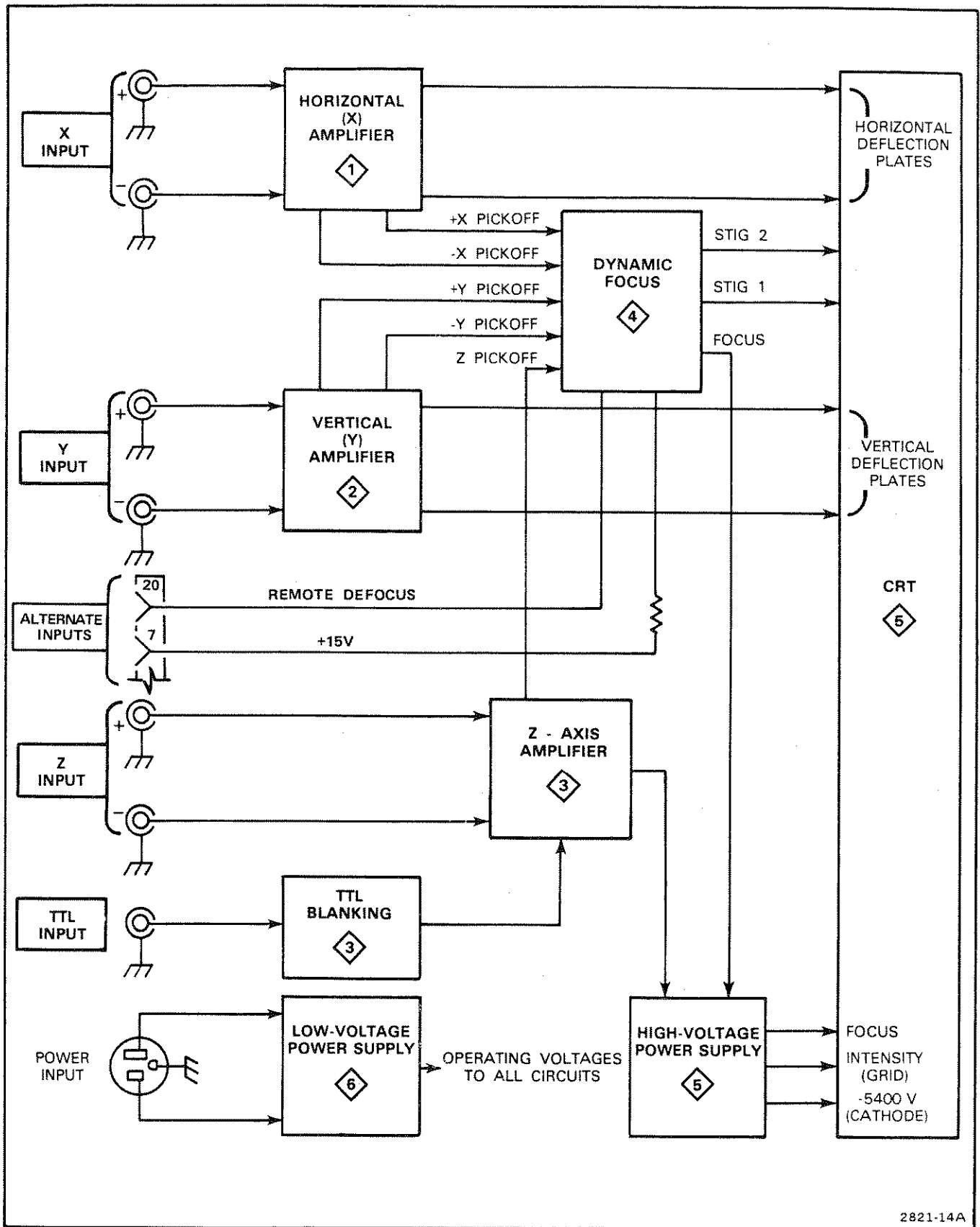

2821-14A

Figure 3-1. 606B Monitor Block Diagram.

Signals can be applied to any X input connector as a single-ended input; or to either noninverting X input (J10, J25) and the -X INPUT (inverting) for a differential input. Refer to Figure 2-3 in Section 2, Operating Information for J25 (ALTERNATE INPUTS connector) pin assignments.

Internal switches S100 and S105 allow selection of either 1X or 5X attenuation of the input signal before it is applied to the X Preamplifier. The 5X position of each attenuator is a frequency-compensated voltage divider. These step attenuators are set in the 1X position when shipped from the factory.

A jumper is provided on each input line to allow selection of either 1 M Ω or 50 Ω input impedance. Both jumpers (P101, P105) should normally be in the same position for proper circuit operation.

Stray signal pickup and cross-coupling are prevented by the use of grounding caps on the unused inputs. (When the ALTERNATE INPUTS connector is used, the grounding cap is installed on the -X INPUT).

X PREAMPLIFIER

The X Preamplifier is a differential amplifier employing two identical and inverting feedback amplifiers. The feedback amplifiers, consisting of Q120A-Q130-Q140 and Q120B-Q135-Q145 supply the push-pull voltage required to drive the X Output Amplifier.

Transistor Q120 provides high input impedance and temperature stability.

The FET gates are diode-clamped on the negative-going overdrive signals to protect the field-effect transistors from excessive input voltages.

The X Gain adjust, R129, allows setting the 8 cm deflection from 0.5 volts to at least 2.5 volts (12.5 volts with attenuator switches S100 and S105 in the 5X position).

Front panel control, R66, provides horizontal positioning by differentially altering the bias voltage on the base elements of Q150 and Q155. Transistors Q150 and Q155 function as a differential current source for the push-pull output of the X Preamplifier.

SCAN LIMITER

Transistors Q180, Q185 and diodes CR180, CR185 prevent overdriving the X Output Amplifier by limiting the X Preamplifier signals to within about 6 volts of each other.

X FOCUS-CORRECTION PICKOFF

Samples of the +X and -X signals are coupled from the X Preamplifier to the X Absolute Value Amplifier (diagram 4) for focus correction in the X axis. A sampling of the +X voltage signal is converted to a current signal by Q170, and the -X voltage signal by Q175, before being applied to the X Absolute Value Amplifier.

X OUTPUT AMPLIFIER

The X Output Amplifier consists of two identical noninverting operational amplifiers connected in a differential configuration. For ease of explanation, only the - side will be discussed.

Transistors Q100-Q120-Q130-Q140-Q150-Q160-Q170 and Q180 are the active components of the -X operational amplifier. Feedback is provided through R174 and C174 to the emitter of Q100.

Transistor Q115 provides additional emitter current to Q100. This current, varied by R119 (X-Plate DC Level), determines the dc voltage output level.

The signal from the X Preamplifier stage is amplified by Q100 and fed through emitter followers Q120-Q130 to a cascode driver Q140. Complimentary amplifiers Q150-Q160 provide the final gain for the -X Output Amplifier signals, with emitter followers Q170-Q180 supplying the high current to drive the capacitive load of the crt plates.

The capacitance between the mounting tabs of transistors Q150-Q160 and the metal work (circuit board and chassis) is minimized by driving a metal shield, to which Q150-Q160 are mounted, with the current output of emitter followers Q170-Q180.

The X GAIN control, R104, provides a 'fine' gain adjustment of at least $\pm 10\%$ of the 8 cm deflection. This control in conjunction with R129, X Gain (internal screwdriver adjust on the Pre-Amplifier board), is normally set to a nominal 1 volt for 8 divisions of deflection (step attenuator in the 1X position).

Potentiometer R109 (Output Amplifier Gain) is provided to match the X Output Amplifier gain to the crt sensitivity, and not to alter the deflection factor. The compensation networks connected to the emitter of Q100 optimize the square wave response to provide the very good settling time performance.



VERTICAL (Y) AMPLIFIER

The Vertical (Y) Amplifier processes the Y input signals (either single-ended or differential) and provides final amplification to drive the vertical deflection plates of the crt. A schematic diagram of the Vertical (Y) Amplifier is shown on diagram 2. A detailed block diagram, identifying each major stage of the Vertical (Y) Amplifier, is superimposed on the schematic with wide shaded lines to conveniently locate the components mentioned here. The stage names (given as sub-headings in the following discussion) can be found in the shaded boxes on diagram 2.

Y INPUTS

Three input signal connectors are provided to the Y Inputs stage: (1) the +Y INPUT (noninverting) bnc connector J30, (2) the -Y INPUT (inverting) bnc connector J40 and (3) the ALTERNATE INPUTS (noninverting) cannon connector J25.

Signals can be applied to any Y input connector as a single-ended input; or to either noninverting Y input (J30, J25) and the -Y INPUT (inverting) for a differential input. Refer to Figure 2-3 in Section 2, Operating Instructions for J25 (ALTERNATE INPUTS connector) pin assignments.

Internal switches S200 and S205 allow selection of either 1X or 5X attenuation of the input signal before it is applied to the Y Preamplifier. The 5X position of each attenuator is a frequency-compensated voltage divider. These step attenuators are set in the 1X position when shipped from the factory.

A jumper is provided on each input line to allow selection of either 1 M Ω or 50 Ω input impedance. Both jumpers (P201, P205) should normally be in the same position for proper circuit operation.

Stray signal pickup and cross-coupling are prevented by the use of grounding caps on the unused inputs. (When the ALTERNATE INPUTS connector is used, the grounding cap is installed on the -Y INPUT).

Y PREAMPLIFIER

The Y Preamplifier is a differential amplifier employing two identical and inverting feedback amplifiers. The feedback amplifiers, consisting of Q220A-Q230-Q240 and Q220B-Q235-Q245 supply the push-pull voltage required to drive the Y Output Amplifier.

Field effect transistor Q220 provides high input impedance and temperature stability.

The FET gates are diode-clamped on the negative-going overdrive signals to protect the field-effect transistors from excessive input voltages.

The Y Gain adjust, R229, allows settling the 8 cm deflection from 0.5 volts to at least 2.5 volts (12.5 volts with attenuator switches S200 and S205 in the 5X position).

Front panel control, R56, provides vertical positioning by differentially altering the bias voltage on the base elements of Q250 and Q255. Transistors Q250 and Q255 function as a differential current source for the push-pull output of the Y Preamplifier.

SCAN LIMITER

Transistors Q280, Q285 and diodes CR280, CR285 prevent overdriving the Y Output Amplifier by limiting the Y Preamplifier signals to within about 5 volts of each other.

Y FOCUS-CORRECTION PICKOFF

Samples of the +Y and -Y signals are coupled from the Y Preamplifier to the Y Absolute Value Amplifier (diagram 4) for focus correction in the Y axis. A sampling of the +Y voltage signal is converted to a current signal by Q270, and the -Y voltage signal by Q275, before being applied to the Y Absolute Value Amplifier.

Y OUTPUT AMPLIFIER

The Y Output Amplifier consists of two identical and noninverting operational amplifiers connected in a differential configuration. For ease of explanation, only the - side will be discussed.

Transistors Q200-Q220-Q230-Q240-Q250-Q260-Q270 and Q280 are the active components of the -Y operational amplifier. Feedback is provided through R274 and C274 to the emitter of Q200.

Transistor Q215 provides additional emitter current to Q200. This current determines the dc voltage output level.

The signal from the Y Preamplifier stage is amplified by Q200 and fed through emitter followers Q220-Q230 to a cascode driver Q240. Complimentary amplifiers Q250-Q260 provide the final gain for the -Y Output Amplifier signals, with emitter followers Q270-Q280 supplying the high current to drive the capacitive load of the crt plates.

The capacitance between the mounting tabs of transistors Q250-Q260 and the metal work (circuit board and chassis) is minimized by driving a metal shield, to which Q250-Q260 are mounted, with the current output of emitter followers Q270-Q280.

The Y GAIN control, R204, provides a 'fine' gain adjustment of at least $\pm 10\%$ of the 8 cm deflection. This control in conjunction with R229, Y Gain (internal screwdriver adjust on the Pre-Amplifier board), is normally set to a nominal 1 volt for 8 divisions of deflection (step attenuator in the 1X position).

Resistor R209 (Output Amplifier Gain) is provided to match the Y Output Amplifier gain to the crt sensitivity, and not to alter the deflection factor.

The compensation networks connected to the emitter of Q200 optimize the square wave response to provide the very good settling time performance.



Z-AXIS AMPLIFIER

The Z-Axis Amplifier processes the Z input signals (either single-ended or differential) and provides the drive signal to control the crt intensity. A schematic diagram of the Z-Axis Amplifier is shown on diagram 3. A detailed block diagram, identifying each major stage of the Z-Axis Amplifier, is superimposed on the schematic with wide shaded lines to conveniently locate the components mentioned here. The stage names (given as sub-headings in the following discussion) can be found in the shaded boxes on diagram 3.

Z INPUTS

Three input signal connectors are provided to the Z Inputs circuit: (1) the +Z INPUT (noninverting) bnc connector J50, (2) the -Z INPUT (inverting) bnc connector J60 and (3) the ALTERNATE INPUTS (noninverting) cannon connector J25.

Signals can be applied to any Z input connector as a single-ended input; or to either noninverting Z input (J50 or J25) and the -Z INPUT (inverting) for a differential input. Refer to Figure 2-3 in Section 2, Operating Instructions for J25 (ALTERNATE INPUTS connector) pin assignments.

A jumper is provided on each input line to allow selection of either 1 M Ω or 50 Ω input impedance. Both jumpers (P102, P106) should normally be in the same position for proper circuit operation.

Stray signal pickup and cross-coupling are prevented by the use of grounding caps on the unused inputs. (When the ALTERNATE INPUTS connector is used, the grounding cap is installed on the -Z INPUT).

Z PREAMPLIFIER

The Z Preamplifier is a differential amplifier employing two identical and inverting feedback amplifiers. The feedback amplifiers, consisting of Q120A-Q130-Q140 and Q120B-Q135-Q145 supply the push-pull voltage required to drive the Z Output Amplifier.

Field-effect transistor Q120 provides high input impedance and temperature stability.

The FET gates are diode-clamped on the negative-going overdrive signals to protect the field-effect transistors from excessive input voltages.

Front-panel control, R46, provides intensity control by differentially altering the bias voltage on the base elements of Q150 and Q155. Transistors Q150 and Q155 function as a differential current source for the push-pull output of the Z Preamplifier.

LIMITER

Diodes CR164 and VR163 prevent overdriving the Z Output Amplifier by limiting the Z Preamplifier signals to within about 6 volts of each other.

Z FOCUS-CORRECTION PICKOFF

Samples of the +Z and -Z signals are combined, and coupled from the Z Preamplifier to the Z Focus circuit (diagram 4) for focus correction in the Z axis. Samples of the +Z and -Z signals are fed to Q180 and Q185. Transistors Q180 and Q185 provide a single-ended output to drive the Z Focus circuit.

Z OUTPUT AMPLIFIER

The push-pull signals from the Z Preamplifier stage are applied to the bases of Q220 and Q225. Transistors Q220-Q225 are voltage-to-current converters which, with Q230, Q240 and Q245 produce a single-ended current signal.

Transistors Q240-Q245-Q250-Q260-Q270 are connected as an operational amplifier, with the feedback path provided through R285-R286 and C285-C286. High-current, low-impedance drive is provided by the complementary configuration of emitter followers Q240-Q245. Complementary amplifiers Q260-Q270 provide the final gain for the Z output signals. Transistor Q250 supplies the additional current necessary at high frequencies (sine wave) to drive the capacitive load. High-frequency compensation is provided by the combination of C285 and R239.

TTL BLANKING

Input signals applied to the rear-panel TTL INPUT bnc connector J70 or ALTERNATE INPUTS connector (see Fig. 2-3) may be either a TTL LO (0 to +0.8 volt) or a TTL HI level (+2.4 to +5 volts). The TTL level necessary to provide blanking of the crt display is determined by the blanking level selecting jumpers P176 and P179. With P176-P179 in the plus (+) position, a TTL LO level will blank the display; with P176-P179 in the minus - position, a TTL HI level will blank the display. Refer to Internal Control and Selector Locations foldout in section 8 for locations of jumpers. With no signal applied to the TTL INPUT connector, an internal pull-up circuit consisting of R175 and R176 will pull the input to a TTL HI level.

Transistors Q170-Q175 are connected as a voltage comparator. The reference voltage for the comparator, developed across R178 and R179, is approximately +2 volts. In the HI blank - position as shown on the schematic, input signals are applied to Q170, and the base of Q175 is connected to the reference voltage. A HI TTL input turns off Q175 and turns on Q165. The bias on Q165 with Q175 off is approximately +10 volts which, when Q165 conducts, forward biases CR170. The TTL blanking stage overrides Z Pre-amplifier signals and clamps the output of the Z-Axis Amplifier LO.



DYNAMIC FOCUS

The Dynamic Focus circuit provides focus correction as the crt beam is deflected to the edges of the display area in both the vertical (Y) and horizontal (X) axis. A schematic diagram of the Dynamic Focus circuit is shown in diagram 4. A detailed block diagram, showing the major stages of this circuit, is superimposed on the schematic diagram with wide shaded lines. The stage names (given as sub-headings in the following discussion) can be found in the shaded boxes on diagram 4.

Geometric defocusing, a contributing factor to overall crt defocusing, occurs when the beam is deflected from the crt center. The electron beam, at center screen, is focused for a particular beam length. When the beam is deflected, either vertically or horizontally, the beam length changes. However, the focusing voltage remains the same. As a result, the display is defocused, appearing larger at the edge of the screen than at crt center (see Figure 3-2).

The Dynamic Focus circuit varies the voltages to the focus and stigmator elements of the crt depending upon the vertical and horizontal positions of the electron beam. Therefore, overall focus is improved over the crt display area.

X ABSOLUTE VALUE AMPLIFIER

The differential output current from the X Focus Correction Pickoff (diagram 1) is fed through P150, pins 1,2 to the X Absolute Value Amplifier of which Q100 and Q110 are the active components.

The X Absolute Value Amplifier converts the differential X pickoff current from the X-Y Pre-Amplifier Board to alternate on outputs (when CR100 is on, CR110 is off and vice versa). This allows implementation of separate focus corrections on each side of the screen.

The output from the X Absolute Value Amplifier stage is fed to the Stigmator 1 Correction Shaper (U150-U160), the Stigmator 2 Correction Shaper and Mixer and the Focus Correction Shaper and Mixer stages.

Y ABSOLUTE VALUE AMPLIFIER

The differential output current from the Y Focus Correction Pickoff is fed through P150, pins 4,3 to the Y Absolute Value Amplifier of which Q120 and Q130 are the active components.

The Y Absolute Value Amplifier converts the differential Y pickoff current from the X-Y Pre-Amplifier Board to alternate on outputs (when CR120 is on, CR130 is off and vice-versa).

This allows implementation of separate focus corrections on the top and bottom of the screen.

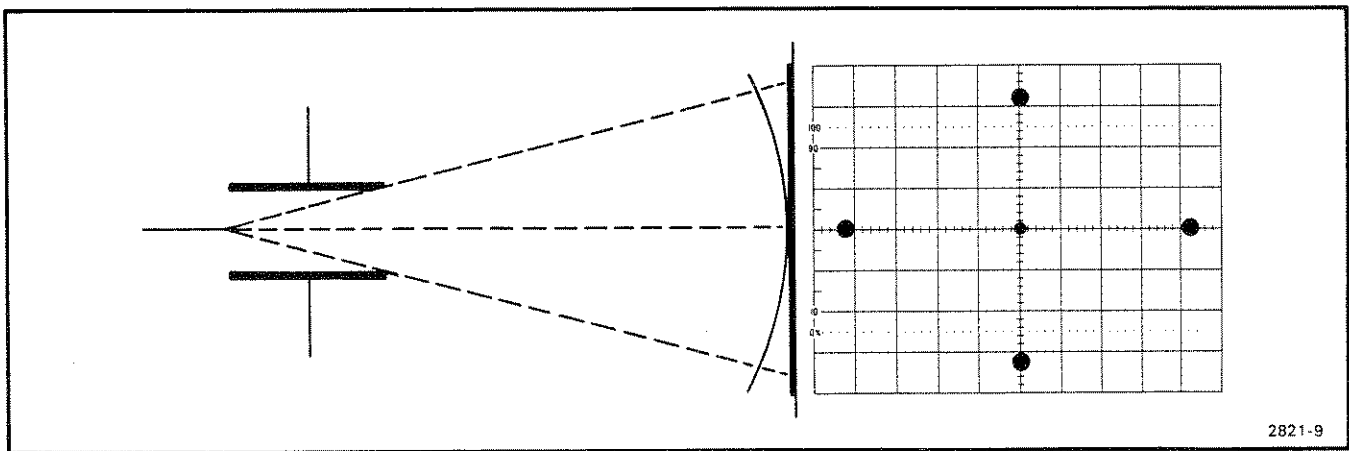

Figure 3-2. Simplified illustration of geometric defocusing.

The output from the Y Absolute Value Amplifier stage is fed to the Stigmator 1 Correction Shaper (U150-U160), the Stigmator 2 Correction Shaper and Mixer and the Focus Correction Shaper and Mixer stages.

STIGMATOR 1 CORRECTION SHAPER

The Stigmator 1 Correction Shaper provides independent gain control of the X times Y function of the crt trace at each corner of the screen.

Information from the X and Y Absolute Value Amplifiers is processed by U150 (multiplier I.C. for the top half of the screen) and U160 (multiplier I.C. for the bottom half of the screen) then combined and fed to the Stigmator 1 Output Amplifier and Level Shifter through a level shifter, Q300.

For reference in this description, assume the crt beam is deflected to the upper left quadrant of the screen ($X < 0$, $Y > 0$). The voltage at the collector of Q100 (X Absolute Value Amplifier) is greater than the clamp voltage (+5.5 volts) while the voltage at the collector of Q110 is clamped to +5.5 volts by CR110.

Similarly, the output of Q120 (Y Absolute Value Amplifier) is active while the voltage at the collector of Q130 is clamped to +5.5 volts by CR130. The output from Q100 is applied to U150 pin 9 through R152 (Top Left S1) and to U160 pin 12 through R161 (Bottom Left S1). The output from Q120 is applied directly to U150 pin 8.

Looking at U150, the difference in the signal at pin 8 (amplitude determined by the location of the trace in the Y axis) and the +5.5 volts on pin 4 is multiplied in U150 by the signal present at pin 9.

At U160, the signal at pin 12 is multiplied in U160 by the signal at pin 8. The signal at pin 8, however, comes from the output of Q130 which is presently clamped. Therefore, the product is zero and there is no change in the current at U160 pin 14.

The outputs at pin 14 of U150 and U160 are fed through a current-to-voltage converter Q300 to the Stigmator 1 Output Amplifier and Level Shifter. The Bias control, R306 is provided to center the output of the Stigmator 1 Output Amplifier and Level Shifter.

Diode CR303 provides overdrive protection to the output amplifier.

STIGMATOR 1 OUTPUT AMPLIFIER AND LEVEL SHIFTER

The stigmator 1 output amplifier is a feedback amplifier consisting of Q310-Q320-Q330-Q340-Q350-Q360. The feedback network consists of R373-C373-C374 with C373 and C374 supplying high frequency compensation. The input signal is applied to the bases of emitter followers Q310-Q320 and fed to complimentary amplifiers Q330-Q340. Complimentary coupled emitter followers Q350-Q360 supply the high current necessary to drive the capacitive load.

The output signal of the stigmator 1 output amplifier at Q360 is approximately 43 volts at zero deflection, and plus or minus 40 volts (from the 43 V reference) at maximum deflection. The correction required by the stigmator 1 elements of the crt needs to be centered around the deflection plate average (125 volts). Transistor Q380 and associated circuitry provides the necessary correction to shift the output voltage level before it's applied to the crt through P298 pin 1.

REMOTE DEFOCUS

The Remote Defocus provides a means of increasing the crt spot size. The circuit creates an error in the stigmator voltage, that, if the crt is otherwise correctly focused, will make the dot larger and still fairly round. (Adjusted for a round dot rather than a small dot.)

Quiescently, Q390 is biased off. When Q390 turns on, (either by placement of the jumper, P398, or by remote input through pin 20 of the rear-panel mounted 25-pin connector) that is, when the voltage at the base of Q390 increases, it pulls current from the emitter of Q380, causing the voltage to drop at the output of the level shifter, Q390.

At pin 7 of the 25-pin connector, +15 V is available through R397 to provide an external bias voltage for the Remote Defocus input, pin 20. The voltage may be altered by a variable resistive divider to ground, to allow external variable control of spot size.

STIGMATOR 2 CORRECTION SHAPER AND MIXER

Outputs from both the X and Y Absolute Value Amplifiers are fed to the appropriate diode shaper circuits, the outputs of which approximate a parabolic transfer function. The resultant waveforms are fed through independent gain controls (R215, R205, R225, R235) to a mixer and clamp circuit (Q240-CR245-CR242-CR243). The output of Q240 is then fed to the Stigmator 2 Output Amplifier and Level Shifter before being applied to V50-6 (crt).

STIGMATOR 2 OUTPUT AMPLIFIER AND LEVEL SHIFTER

The stigmator 2 output amplifier is a feedback amplifier consisting of Q250-Q260-Q270-Q280. The feedback network consists of R283-C283 with C283 supplying high-frequency compensation.

Theory of Operation—606B

Transistors Q270 and Q280 are connected as a collector coupled complimentary amplifier to provide a fast linear output signal. Ac coupling is provided by C275 to decrease the high-frequency risetime.

The output signal of the amplifier at Q280 ranges from approximately +5 volts to +75 volts. The correction required by the Stigmator 2 element of the crt needs to be centered around the deflection plate average (125 volts). Transistor Q290 and associated circuitry provide the necessary correction to shift the output voltage level before it's applied to the crt (V50-6).

FOCUS CORRECTION SHAPER AND MIXER

Outputs from both the X and Y Absolute Value Amplifiers are fed to the appropriate diode shaper circuits (Q400-CR400, Q410-CR410, Q420-CR420, Q430-CR430) the outputs of which approximate a parabolic transfer function. The resultant waveforms are fed through independent gain controls (R415, R405, R425, R435) to a mixer and clamp circuit (Q435-CR433-CR434-CR437). The output of Q435 is fed to the Focus Output Amplifier.

Z FOCUS

A single-ended output current from the Z-Focus-Correction Pickoff stage on diagram 3 is coupled through P150 pin 5 to the emitter of Q140. The output of the current-to-voltage converter Q140 is adjusted (Z-Focus correction) and fed through limiting diodes CR458-CR459 to the input of the Focus Output Amplifier.

FOCUS OUTPUT AMPLIFIER

A correction voltage from the Z Focus stage is combined with the output of the Focus Correction Shaper and Mixer. The resultant waveform is processed by the Focus Output Amplifier and fed through P195-1 to the Focus Element DC Restorer circuit on diagram 5.

The Focus Output Amplifier is a feedback amplifier consisting of Q440-Q450-Q460-Q470-Q480-Q490. The feedback network consists of R492-R493-C492-C493 with C492 and C493 supplying high-frequency compensation.

The input signals are combined at the bases of emitter followers Q440-Q450 and fed to complimentary amplifiers Q460-Q470. Transistors Q460-Q470 provide the final gain, with complimentary coupled emitter followers Q480-Q490 supplying the high current necessary to drive the capacitive load.



CONVERTER AND HIGH-VOLTAGE POWER SUPPLY

The Converter and High-Voltage Power Supply provides the voltage levels and control circuits necessary for operation of the deflection system and the cathode-ray tube (crt). A schematic diagram of the Converter and High-Voltage Power Supply is shown on diagram 5. A detailed block diagram, showing each major stage of this circuit, is superimposed on the schematic diagram with wide shaded lines. The stage names (given as sub-headings in the following discussion) can be found in the shaded boxes on diagram 5.

CONVERTER OSCILLATOR

The Converter Oscillator uses an external resistance, R124-R125 to establish a constant charging current into C121. Capacitor C121 provides a linear ramp voltage used as a reference for the comparator. The comparator then couples the information from the Error Amplifier to the Converter Base Drive circuit.

The discharge time of C127 (Converter Base Drive stage) determines the minimum pulse width of the oscillator output pulse. This pulse is used as a blanking pulse to both outputs (U120, pins 11,12,13,14) to insure that there is no possibility of having both outputs on simultaneously during transition.

ERROR AMPLIFIER

The Error Amplifier stage is a differential input, transconductance amplifier.

The 250 volt supply is sampled by R101-R102 and R110-R112 and fed to U120, pin 1, the - input to the Error Amplifier. The other input (U120, pin 2) is connected to a reference voltage provided by the voltage divider R114-R115.

Any increase or decrease in the voltage at U120, pin 1 will cause a corresponding decrease or increase in the output of the Error Amplifier.

The over-voltage circuit will shut down U120's output when the voltage of the +95 volt supply reaches approximately 110 volt (VR109); the Over-Voltage transistor turns on, thereby pulling the Error Amplifier output toward ground.

CURRENT LIMITER

The Current Limiter stage provides circuit protection by disabling the Error Amplifier output. Shutdown will occur when a current of approximately 1.5 amperes is exceeded in the Converter Output transistors Q180-Q190. The current limit amplifier (U120, pin 4) turns on, pulling the output of the Error Amplifier toward ground, thus shutting off the outputs.

CONVERTER BASE DRIVE

The Converter Base Drive circuit uses the pulses from the Converter Oscillator to generate the pulse width modulated signal necessary to drive base-drive transformer T170.

Quiescently, the output transistors of U120 (pins 11-12, 13-14) are off. Current flows from the +20 volt supply to Q165-Q175 via VR160-VR170, R135-R136, and R152-R145.

Zener diodes VR160-VR170 are conducting, reverse biasing CR135-CR136. (The base/emitter junction potential of Q165-Q175 plus the zener drop of VR160-VR170 are felt at the cathodes of CR135-CR136. The base of Q130 is at the +5 volt Reference Regulator level from U120, pin 16.)

Transistor Q130 is off, and the base of Q150 is pulled to its emitter potential through R130. Since Q150 is off, as just stated, and Q165-Q175 are conducting, transformer T170 is shorted.

In operation, the output transistor (U120, pins 13, 14) is turned on (saturated). Two events simultaneously occur; (1) Transistor Q170 saturates and turns off Q175, and (2) the on current of U120, pins 13 and 14 increases the voltage drop across R136 and turns on CR136, Q130 and Q150.

Transistor Q165 pulls current through the upper half of T170 from current source Q150.

CONVERTER OUTPUT

The Converter Output circuit processes the output of the Converter Base Drive and couples the voltage generated in the primary of T170 to the Deflection Voltage Supplies and the HV Regulator stages.

The output of Q165 is coupled through T170 to the base of Q180. Transistor Q180 turns on to charge the LC tank (L185-C185-C187) and supply a current through the primary of T200. Transistor Q180 is turned off and a ringing effect results due to the energy stored in the LC tank. Diode CR190 turns on then off; after CR190 turns off, diode CR180 turns on, then off again. When CR180 turns off, transistor Q190 turns on and pulls energy back through the transformer, T200.

DEFLECTION VOLTAGE SUPPLIES

The Deflection Voltage Supplies stage provide +95 volts, +250 volts and +300 volts for the monitor.

+95 Volts

The ac voltage from pins 18 and 20 of T200 is rectified by CR205-CR206, filtered by L205-C205 and fed to the circuit locations indicated on the schematic.

+250 Volts

The ac voltage from pins 22 and 16 of T200 is rectified by CR201-CR202, filtered by L201-CL201 and fed to the circuit locations indicated on the schematic.

+300 Volts

The ac voltage from pin 15 of T200 is rectified by CR209 and filtered by C209 before being applied to the H. V. Regulator.

H. V. REGULATOR

The H. V. Regulator provides a small feedback voltage to the input of the 4X multiplier to keep its output to a specified limit.

The converter transformer T200 provides a 1300 volt peak signal to the 4X multiplier. The 4X multiplier consists of C67, CR171, CR173, CR177, CR179, C173, C162 and C171. Filtering of the resultant -5400 volts is provided by R156-C152, C162 and the regulator loop.

The -5400 volts is sampled at R127D and fed to the + input of U280 through P400-9. The voltage at P400-9 is adjusted to approximately 0 volt by R295 (H. V. ADJ.). Input protection, feedback and compensation are provided to U280 by CR283-CR285, R270 and R275-C275, respectively.

The output of U280 is fed through R266-R265 to the base of the regulator transistor, Q260. Transistor Q260 in conjunction with Q250 sets the voltage on the feedback line (through R260, R250, R153) to the multiplier return (junction of C162-C171) to set the voltage on the anode of CR171. (The cathode will go more or less positive but remain above ground.)

CONTROL-GRID DC RESTORER

The Control-Grid DC Restorer stage couples the dc and low-frequency components of the Z-Axis Amplifier output signal to the crt control grid (pin 3 of V50). This allows the Z-Axis Amplifier to control the crt beam intensity. The potential difference between the Z-Axis Amplifier output level and the crt control grid prohibits direct coupling.

The Control-Grid DC Restorer stage is actually a cathode-referenced bias supply for the crt control grid. Quiescently, its output voltage is more negative than the crt cathode by an amount determined by the Z-Axis Amplifier output level and the setting of the Grid Bias adjustment, R245. (The cutoff voltage at the crt control grid is typically about 100 volts more negative than the crt cathode level.)

The Control-Grid DC Restorer stage is divided into two sections for ease of explanation. The first section can be considered a modulator at low-voltage potentials, and the remaining section as a demodulator at high-voltage potentials.

Modulator

When the secondary winding output of T200 (pin 16) swings positive, C131 charges through C230, R230, R236 and R131 to a voltage level determined by the setting of the Grid Bias adjustment, R245. At this voltage level (approximately 100 volts), diode CR240 conducts, preventing any additional increase in the positive voltage across C131. When the secondary-winding output swings negative, diode CR240 turns off. Then CR232 conducts and clamps the negative excursion at C131 to the voltage level of the Z-Axis Amplifier output. The result is a square-wave output from the Modulator; the output amplitude is determined by the difference between the Z-Axis Amplifier output level and the Grid Bias adjustment setting. This square wave is coupled through C131 to the Demodulator.

Demodulator

The Demodulator rectifies the signal from the Modulator and references it to the crt cathode supply level. The positive swing is limited by CR137 to the level of the cathode supply; the negative excursion is coupled through CR134 to C133. Quiescently, C133 will charge to about -5400 volts through R148. After repetitive cycles from C131, C133 will charge to its maximum negative level. Capacitor C133 filters the output of the demodulator, and also provides a path for the high-frequency portions of the Z-Axis Amplifier output signal to be coupled to the crt control grid.

The remainder of the components provide circuit protection in the event of a high-voltage arc, or other malfunction.

FOCUS-ELEMENT DC RESTORER

The Focus-Element DC Restorer stage couples the dc and low-frequency components of the Dynamic Focus correction signals (diagram 4) to the crt focus element of V50. This allows the Dynamic Focus circuit to control the focus-element potential. The potential difference between the Dynamic Focus output and the focus element prohibits direct coupling.

The Focus-Element DC Restorer stage is divided into 2 sections for ease of explanation. The first section can be considered a modulator at low-voltage potentials and the remaining section a demodulator at high-voltage potentials.

Modulator

When the secondary-winding output at T200 (pin 16) swings positive, C111 charges through C215, R215 and R220 to a voltage level determined by the output level from the Focus Output Amplifier stage of the Dynamic Focus circuit (diagram 4). At this voltage level (approximately +15 volts for center-screen deflection) CR217 conducts, preventing any additional increase in positive voltage across C111. When the secondary-winding output swings negative, CR217 turns off. Then CR218 conducts and clamps the negative excursion at

C111 a diode drop below ground. The result is a square-wave output from the Modulator, with the output amplitude determined by the difference between the level of the Dynamic Focus circuit (diagram 4) and approximately ground. The Modulator output is coupled through C111 to the Demodulator.

Demodulator

The Demodulator rectifies the signal from the Modulator and references it to the potential on C121. The potential on C121 is determined by voltage divider R127A, R127B and Coarse Focus control R125. The negative swing of the supply is limited by CR116 to the level of C121; the positive excursion is coupled through CR114 and R112 to C112. Quiescently, C112 will charge to about -3250 volts through R112. After repetitive cycles from C111, C112 will charge to the cathode supply level. Capacitor C112 filters the output of the demodulator, and also provides a path for the high-frequency portions of the focus-correction signal to be coupled to the crt focus element at V50.

The remainder of the components provide circuit protection in the event of a high-voltage arc or other malfunction.

Geometry adjustment, R185, varies the positive level on the geometry element to control the overall geometry of the display. TRACE ALIGN adjustment, R290, controls the current through L50 to provide adjustment of the display alignment.

The Stig 1 and Stig 2 functions are described in the circuit description of the Dynamic Focus, diagram 4.



LOW-VOLTAGE POWER SUPPLY

The Low-Voltage Power Supply provides the operating power for the Monitor. Electronic regulation is used to provide stable, low-ripple output voltages. A schematic diagram of the Low-Voltage Power Supply is shown on diagram 6 at the rear of this manual. A detailed block diagram, showing each major stage of this circuit, is superimposed on the schematic with wide shaded lines. The stage names (given as sub-heading in the following discussion) can be found in the shaded blocks on diagram 6.

POWER INPUT

Power is applied to the primary of transformer T95 through fuse F90, thermal cutout S92, POWER switch S90, and Line-Voltage Selector plug P390. The Line-Voltage Selector plugs allow changing the primary winding taps of T95 to meet different line-voltage and regulating range requirements. Line fuse F90 should be changed for each nominal line voltage (current rating of fuse for 220 volt operation must be 0.6 ampere slow-blowing type; for 120 volt operation the current rating of the fuse must be 1.2 ampere slow-blowing type).

Thermal cutout S92 provides thermal protection for this instrument. If the internal temperature of the instrument exceeds a safe operating level, S92 opens to interrupt the applied power. When the temperature returns to a safe level, S92 automatically closes to re-apply the power.

RECTIFIER AND FILTER

A full-wave bridge circuit, composed of CR301-CR302-CR305-CR306 rectifies the ac voltage from the secondary of T95. Filtering is provided by C300-C305-C310-C315.

+18 VOLT UNREGULATED SUPPLY

The +18 Volt Unregulated Supply provides the +18 volt unregulated power for the Converter Board on diagram 5. Fuse F310 provides circuit protection in the event of an overload.

-18 VOLT UNREGULATED SUPPLY

The -18 Volt Unregulated Supply provides the -18 volt unregulated power for the Converter Board. Fuse F325 provides circuit protection in the event of an overload.

+15 VOLT REGULATED SUPPLY

The +15 Volt Regulated Supply, in addition to providing power to circuitry throughout the instrument, provides a reference-voltage source for all other power supplies. The regulator for the +15 volt Regulated Supply is a feedback amplifier system that operates between ground and the +18 Volt Unregulated Supply. Current to the load is delivered by series-pass transistor Q350, which is located in the output side of the supply. The supply voltage is established by the drop across resistive-divider network R335-R337-R339. The feedback through this network is compared to the reference level established at the base of Q320 by the voltage drop across VR327. Any variation in output voltage of the supply (due to ripple, change of current through the load, etc.), is immediately transmitted to the base of Q350 and cancelled by a change in Q350 conduction, maintaining a steady output.

The output of the supply is set to exactly +15 volts by adjustment of R337, the +15 V Adjust.

Transistor Q340 protects the +15 volt series regulator (Q350) if excess current is demanded from this supply. Essentially, all current from this supply flows through R351. When excess current is demanded from the +15 volt series regulator, due to a short circuit or similar malfunction at the output of this supply, the voltage drop across R351 increases enough to turn on Q340. The resulting current through Q340 reduces the conduction of Q350 to limit the supply current to a safe level. Fuse F315 provides circuit protection in the event of an overload (long term) or regulator malfunction.

-15 VOLT REGULATED SUPPLY

The regulator for the -15 Volt Regulated Supply consists of series-pass transistor Q390 and error amplifier Q360-Q370-Q380. This is a feedback amplifier system similar to that just described for the +15 Volt Regulated Supply.

The center of resistive-divider network R377-R379 is set by the error amplifier to be zero volts, with respect to ground, during normal operation. Any variation in output from the -15 Volt Regulated Supply is coupled to the error amplifier, which changes the bias of the -15 volt series regulator (Q390). This change in bias, and resulting change in conduction of the regulator, cancels the output variation to maintain a steady level from the supply.

Diode CR385 protects the -15 volt series regulator (Q390) if excess current is demanded from this supply. Essentially, all current from this supply flows through R390. When excess current is demanded from the -15 volt series regulator, due to a short circuit or similar malfunction at the output of this supply, the voltage drop across R390 increases enough to forward bias CR385. This increases the conduction of Q380, which then reduces the conduction of Q390 to limit the supply current to a safe level. Fuse F320 provides circuit protection in the event of an overload (long term) or regulator malfunction.



INTERCONNECTIONS

Diagram 7 shows the six circuit boards in the Monitor, and the source and destination (schematic number) of all signals and voltages applied to each pin.

MAINTENANCE

This section of the manual contains information for performing preventive maintenance, troubleshooting, and corrective maintenance for the 606B Monitor.

PREVENTIVE MAINTENANCE

Preventive maintenance, when performed on a regular basis, can prevent or forestall instrument breakdown and may improve the reliability of the instrument. The severity of the environment to which the instrument is subjected will determine the frequency of maintenance. A convenient time to perform preventive maintenance is preceding electrical adjustment of the instrument.

VISUAL INSPECTION

The 606B Monitor should be inspected occasionally for such defects as broken connections, improperly seated semiconductors, damaged or improperly installed circuit boards, and heat-damaged parts. The corrective procedure for most visible defects is obvious; however, particular care must be taken if heat-damaged parts are found. Overheating usually indicates other trouble in the instrument; therefore, the cause of overheating must be corrected to prevent recurrence of the damage.

CLEANING

The 606B Monitor should be cleaned as often as operating conditions require. Accumulation of dirt in the instrument can cause overheating and component breakdown. Dirt on components acts as an insulating blanket which prevents efficient heat dissipation, and also provides an electrical conduction path which may result in instrument failure. Cabinet panels will provide some protection against dust in the interior of the instrument.

CAUTION

Avoid the use of chemical cleaning agents which might damage the plastics used in this instrument. Use a nonresidue type of cleaner, preferably isopropyl alcohol or total denatured ethyl alcohol. Before using any other type of cleaner, consult your Tektronix Service Center.

EXTERIOR

Loose dust accumulated on the outside of the instrument can be removed with a soft cloth or small brush. The brush is particularly useful for dislodging dirt on and around the front-panel controls. Dirt which remains can be removed with a soft cloth dampened in a mild detergent and water solution. Abrasive cleaners should not be used.

CRT

Clean the crt faceplate with a soft, lint-free cloth dampened with denatured alcohol.

INTERIOR

Cleaning the interior of the instrument should be performed in conjunction with the visual inspection. The best way to clean the interior is to blow off the accumulated dust with dry, low-velocity air (approximately 5 lb/in²). Remove any dirt which remains with a soft brush or a cloth dampened with a mild detergent and water solution. A cotton-tipped applicator is useful for cleaning in narrow spaces, or for cleaning more delicate circuit components.

CAUTION

Circuit boards and components must be dry before applying power to the instrument to prevent damage from electrical arcing.

The high-voltage circuits should receive special attention. Excessive dirt in this area may cause high-voltage arcing and result in improper instrument operation.

SEMICONDUCTOR CHECKS

Periodic checks of semiconductors are not recommended. The best check of semiconductor performance is actual operation in the instrument. More details on semiconductors are given under Troubleshooting later in this section.

PERIODIC ELECTRICAL ADJUSTMENT

To ensure accurate measurements, check the electrical adjustment of this instrument after each 1000 hours of operation, or every six months if used infrequently. In addition, replacement of components may necessitate adjustment of the affected circuits. Complete adjustment instructions are given in Section 5, Calibration. This procedure can be helpful in localizing certain troubles in the instrument, and in some cases, may correct them.

TROUBLESHOOTING

The following information is provided to facilitate troubleshooting of the Monitor. Information contained in other sections of this manual should be used in conjunction with the following data to aid in locating a defective component. An understanding of the circuit operation is helpful in locating troubles. See Section 3, Theory of Operation, for this information.

TROUBLESHOOTING AIDS

DIAGRAMS

Complete schematic diagrams are located on the foldout pages in Section 8, Diagrams and Circuit Board Illustrations. The component number and electrical value of each component in this instrument are shown on these diagrams. (See the first page of the Diagrams and Circuit Board Illustrations section for definitions of the reference designators and symbols used to identify components in this instrument.) Important voltages and numbered waveform test points are also shown on the diagrams. Corresponding numbered waveforms are located adjacent to each diagram. The portions of circuits mounted on circuit boards are enclosed with heavy solid black lines. Each schematic diagram is divided into functional stage blocks, as indicated by the wide shaded lines. These functional blocks are described in detail in Section 3, Theory of Operation.

CIRCUIT BOARD ILLUSTRATIONS

A circuit board location illustration appears on the back of the foldout page facing the schematic diagram. In addition, an illustration of the circuit board is included here, to identify the physical location of the components and waveform test points that appear on the schematic diagram. Each circuit board illustration is arranged in a grid locator with an index to facilitate rapid location of components contained in the schematic diagrams.

TROUBLESHOOTING CHART

A troubleshooting chart is given in Section 8, Diagrams and Circuit Board Illustrations, to aid in locating a defective circuit. The shaded blocks of the Troubleshooting Chart indicate stages which may cause the indicated malfunction. The stage names given in shaded blocks correspond directly to the names given in the functional stage blocks of the schematic diagrams. The circuits are discussed in detail in Section 3, Theory of Operation.

TEST POINT AND ADJUSTMENT LOCATIONS

To aid in locating test points and adjustable components called out in the Calibration procedure, a Test Point and Adjustment Locations foldout page is provided in Section 8, Diagrams and Circuit Board Illustrations.

COMPONENT COLOR CODING

The instrument contains brown composition resistors, some metal-film resistors and some wire-wound resistors. The resistance values of wire-wound resistors are usually printed on the component body. The resistance values of composition resistors and metal-film resistors are color coded on the components using the EIA color code (some metal-film resistors may have the value printed on the body). The color code is read starting with the stripe nearest the end of the resistor. Composition resistors have four stripes, which consist of two significant figures, a multiplier, and a tolerance value (see Fig. 4-1). Metal film resistors have five stripes consisting of three significant figures, a multiplier, and a tolerance value.

The values of common disc capacitors and small electrolytics are marked on the side of the component body. The white ceramic and epoxy-coated tantalum capacitors used in the instrument are color coded using a modified EIA code (see Fig. 4-1).

The cathode end of glass-encased diodes is indicated by a stripe, a series of stripes, or a dot. The cathode and anode ends of metal-encased diodes can be identified by the diode symbol marked on the body.

SEMICONDUCTOR LEAD CONFIGURATIONS

Figure 4-2 shows the lead configurations of the semiconductors in the 606B Monitor.

MULTI-PIN CONNECTOR HOLDERS

The multi-pin connector holders are keyed with two triangles, one on the holder and one on the circuit board. When a connection is made perpendicular to a circuit board surface, the orientation of the triangle on the end-lead multi-pin connector holder is determined by the placement of the multi-pin connector index (see Fig. 4-3).

COLOR CODE

① ② AND ③ - 1st, 2nd, AND 3rd SIGNIFICANT FIGS.

Ⓣ AND/OR ⓉⓈ COLOR CODE MAY NOT BE PRESENT ON SOME CAPACITORS;

Ⓜ - MULTIPLIER; Ⓣ - TOLERANCE;

ⓉⓈ - TEMPERATURE COEFFICIENT.

Ⓟ - POSITIVE (+) POLARITY AND VOLTAGE RATING.

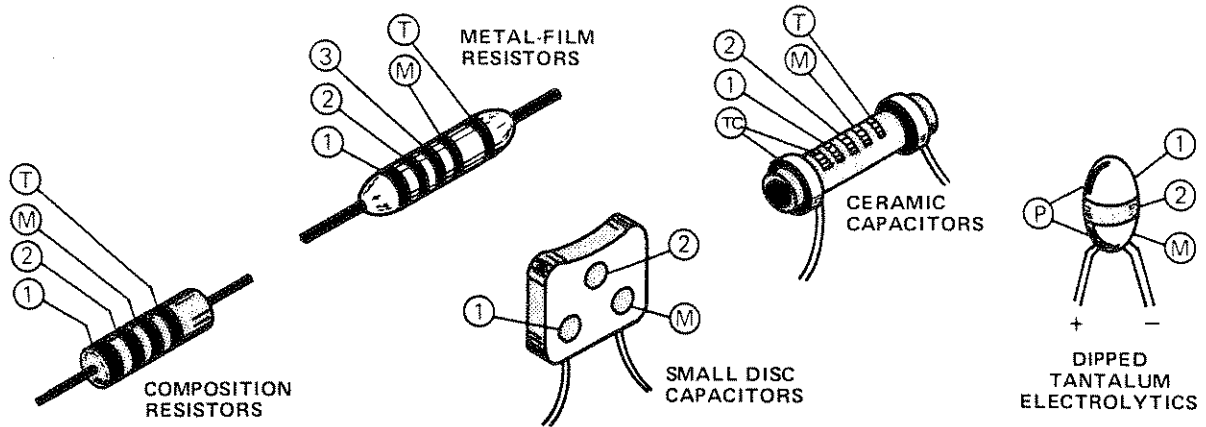

COLOR	SIGNIFICANT FIGURES	RESISTORS		CAPACITORS			DIPPED TANTALUM VOLTAGE RATING
		MULTIPLIER (OHMS)	TOLERANCE	MULTIPLIER (pF)	TOLERANCE		
					OVER 10pF	UNDER 10 pF	
BLACK	0	1	----	1	±20%	± 2pF	4VDC
BROWN	1	10	±1%	10	±1%	±0.1pF	6VDC
RED	2	10 ² or 100	±2%	10 ² or 100	±2%	----	10VDC
ORANGE	3	10 ³ or 1 K	±3%	10 ³ or 1000	±3%	----	15VDC
YELLOW	4	10 ⁴ or 10K	±4%	10 ⁴ or 10,000	+100% -0%	----	20VDC
GREEN	5	10 ⁵ or 100 K	±1/2%	10 ⁵ or 100,000	±5%	±0.5pF	25VDC
BLUE	6	10 ⁶ or 1 M	±1/4%	10 ⁶ or 1,000,000	----	----	35VDC
VIOLET	7	----	±1/10%	10 ⁷ or 10,000,000	----	----	50VDC
GRAY	8	----	----	10 ⁻² or 0.01	+80% -20%	±0.25pF	----
WHITE	9	----	----	10 ⁻¹ or 0.1	±10%	±1pF	3VDC
GOLD	----	10 ⁻¹ or 0.1	±5%	----	----	----	----
SILVER	----	10 ⁻² or 0.01	±10%	----	----	----	----
NONE	----	----	±20%	----	±10%	±1pF	----

(1862-74) 1866-57

Figure 4-1. Color code for resistors and capacitors.

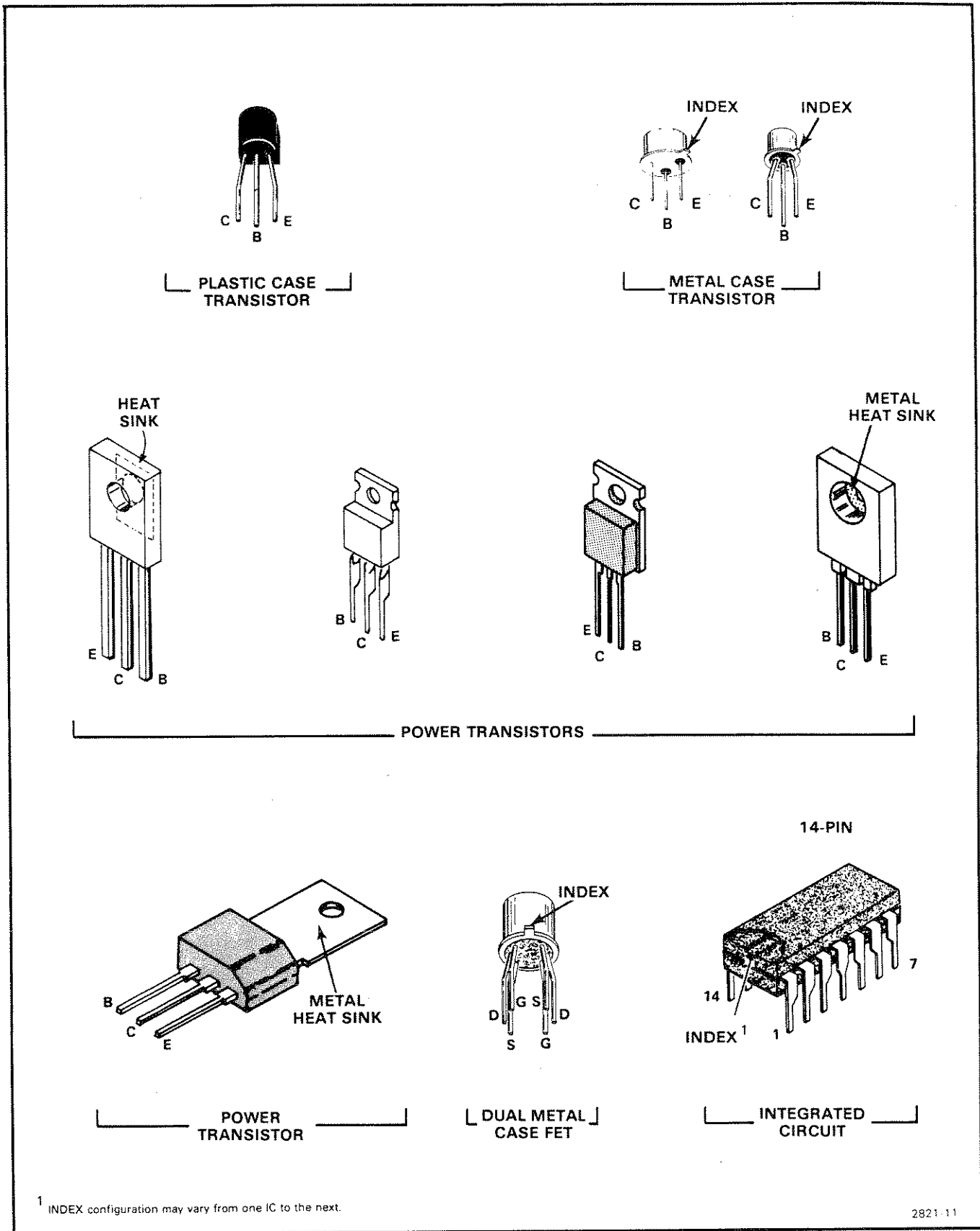

¹ INDEX configuration may vary from one IC to the next.

Figure 4-2. Semiconductor lead configuration.

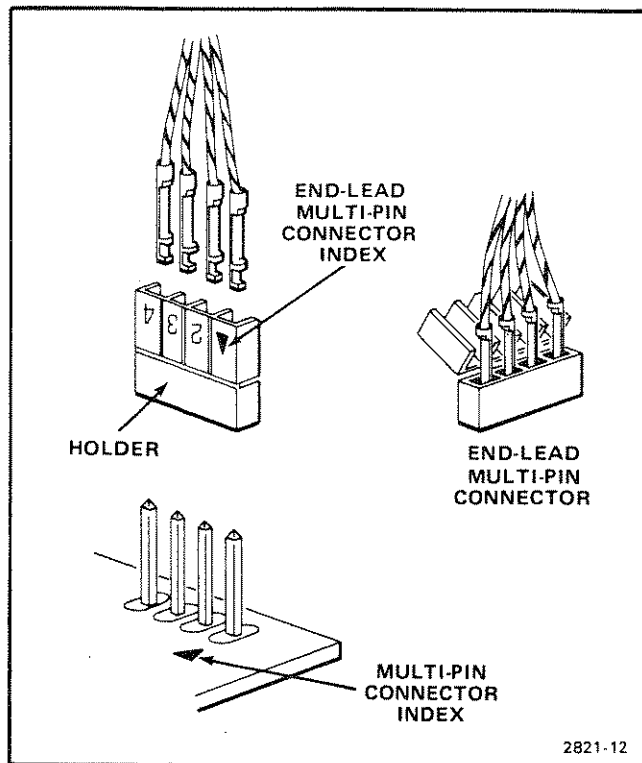

Figure 4-3. Orientation of multi-pin connector holders.

TROUBLESHOOTING EQUIPMENT

The following equipment, in addition to that listed in the Performance Check and Adjustment section, is useful for troubleshooting the 606B Monitor:

Semiconductor Tester

Description: Dynamic-type tester.

Purpose: To test the semiconductors used in this instrument.

Recommended Type: TEKTRONIX Type 576 Curve Tracer or equivalent.

Multimeter

Description: Ten megohm input impedance and 0 to 300 volts range, ac and dc; ohmmeter, 0 to 50 megohms. Accuracy, within 3%. Test probes must be insulated to prevent accidental shorting.

Purpose: General troubleshooting.

Test Oscilloscope

Description: Frequency response, dc to ten megahertz minimum; deflection factor, one millivolt/division to five volts/division. A 10X, ten megohm voltage probe should be used to reduce circuit loading for voltage measurements.

Purpose: To check operating waveforms.

Service Extender Kit

Description: The 067-0958-00 Service Extender kit consists of all the electrical parts necessary to mount the High Voltage board (A5) at a right angle with the Converter board (A4). This provides access to the component side of the High Voltage board as well as expose circuitry on the Converter board for troubleshooting purposes.

TROUBLESHOOTING TECHNIQUES

This troubleshooting procedure is arranged in an order that checks the simple trouble possibilities before proceeding with extensive troubleshooting. The first few checks assure proper connection, operation, and adjustment. If the trouble is located by these checks, the remaining steps aid in locating the defective component. When the defective component is located, replace it using the replacement procedure given under Component Replacement in this section.

1. CHECK CONTROL SETTINGS

Incorrect control settings can indicate a trouble that does not exist. If there is any question about the correct function or operation of any control on the 606B, refer to Section 2, Operating Instructions.

2. CHECK ASSOCIATED EQUIPMENT

Before proceeding with troubleshooting, check that the equipment used with this instrument is operating correctly. Also, check that the input signals are properly connected and that the interconnecting cables are not defective. Check the line-voltage source.

WARNING

Although this Monitor is not to be connected to a patient, interconnecting this Monitor to other equipment can result in the application of excessive current to a patient. It is extremely important that the interconnection is made in accordance with NFPA 76B-T, Tentative Standard for the Safe Use of Electricity in Patient Care Areas of Health Care Facilities, section 3038, "Signal Transmission Between Appliances".

3. VISUAL CHECK

Visually check that portion of the instrument in which the trouble is located. Many troubles can be found by visible indications, such as unsoldered connections, broken wires, damaged circuit boards and damaged components.

4. CHECK INSTRUMENT ADJUSTMENT

Check the electrical adjustment of this instrument, or of the affected circuit if the trouble appears in one circuit. The apparent trouble may only be a result of misadjustment. Complete adjustment instructions are given in Section 5, Calibration.

5. ISOLATE TROUBLE TO A CIRCUIT

To isolate trouble to a particular circuit, note the trouble symptom. The symptom often identifies the circuit in which the trouble is located. When trouble symptoms appear in more than one circuit, check the affected circuits by taking voltage and waveform readings.

Incorrect operation of all circuits often indicates trouble in the power supplies. Check first for the correct output voltage of the individual supplies. A defective component elsewhere in the instrument can appear as a power-supply trouble and may also affect the operation of other circuits. Table 4-1 lists the output voltage range and typical ripple of the power supplies in this instrument. These voltages are measured between the power-supply test points and ground (see the Test Point and Adjustment Locations foldout pages in Section 8, Diagrams and Circuit Board Illustrations, for test point locations). If the power-supply voltage and ripple is within the listed range, the supply can be assumed to be working correctly. If outside the range, the supply may be misadjusted or operating incorrectly. Use the procedure given in Section 5, Calibration, to adjust the power supplies.

TABLE 4-1
Low-Voltage Supply Limits

Supply (dc)	Test Point	Limits (Volts dc)	Ripple (p-p)
+15 V	TP352	+14.95 to +15.05	2 mV or less
-15 V	TP354	-15.2 to -14.8	2 mV or less
+95 V	TP351	+94.0 to +98.0	100 mV or less
+250 V	TP350	+249 to +251	150 mV or less

Figure 8-17 in Section 8, Diagrams and Circuit Board Illustrations, provides a guide for locating a defective circuit. Start at the top left of the Troubleshooting Chart and perform the checks given across the top of the chart until the indicated results are not found. Then proceed to further checks, or the circuit in which trouble is suspected, as listed underneath the step. The shaded blocks of the Troubleshooting Chart indicate circuit stages that may cause the malfunction, and correspond

directly to the functional blocks on the schematic diagrams. The circuits listed are discussed in detail in Section 3, Theory of Operation. After the defective circuit has been located, proceed with steps 6 and 7 of Troubleshooting Techniques to isolate the defective component.

6. CHECK VOLTAGES AND WAVEFORMS

Often the defective component can be located by checking for the correct voltages or waveforms in the circuit. Typical voltages and waveforms are given in Section 8, Diagrams and Circuit Board Illustrations.

NOTE

Voltages and waveforms given in Section 8, Diagrams and Circuit Board Illustrations, are not absolute and may vary slightly between Monitors. To obtain operating conditions similar to those used to make these readings, see the appropriate schematic.

7. CHECK INDIVIDUAL COMPONENTS

The following procedures describe methods of checking individual components. Components which are soldered in place are best checked by first disconnecting one end. This isolates the measurement from the effects of surrounding circuitry.



To avoid electric shock, always disconnect the Monitor from the power source before replacing components.

Fuses

Check for open fuses by checking the continuity with an ohmmeter. The location and rating of power-supply fuses is shown in Figure 1-1, General Information section.

Transistors

A good check of transistor operation is actual performance under operating conditions. A transistor can most effectively be checked by substituting a new component for it (or one which has been checked previously). However, be sure that circuit conditions are not such that a replacement transistor might also be damaged. If substitute transistors are not available, use a dynamic tester. Static-type testers are not recommended, since they do not check operation under simulated operating conditions.

Integrated Circuits

Integrated circuits can be checked with a voltmeter, test oscilloscope, or by direct substitution. A good understanding of the circuit operation is essential when troubleshooting circuits using integrated circuits. In addition, operating waveforms, logic levels, and other operating information for the integrated circuits are given

in Section 3, Theory of Operation, and Section 8, Diagrams and Circuit Board Illustrations. Use care when checking voltages and waveforms around the integrated circuits so that adjacent leads are not shorted together. A convenient means of clipping a test probe to the in-line multi-pin integrated circuits is with an integrated-circuit test clip. This device also doubles as an integrated-circuit extraction tool.

Diodes

A diode can be checked for an open or shorted condition by measuring the resistance between terminals with an ohmmeter set on a scale having a low internal source current, such as the R X 1K scale. The resistance should be very high in one direction and very low when the meter leads are reversed.

CAUTION

When checking diodes, do not use an ohmmeter scale that has a high internal current, since high currents may damage the diodes under test.

Resistors

Check the resistors with an ohmmeter. Resistor tolerance is given in Section 7, Replaceable Electrical Parts. Normally, resistors do not need to be replaced unless the measured value varies widely from the specified value.

Capacitors

A leaky or shorted capacitor can best be detected by checking resistance with an ohmmeter on the highest scale. Do not exceed the voltage rating of the capacitor. The resistance reading should be high after initial charge of the capacitor. An open capacitor can best be detected with a capacitance meter or by checking if the capacitor passes ac signals.

8. REPAIR AND READJUST THE CIRCUIT

If any defective parts are located, follow the replacement procedures given under Component Replacement in this section. Check the performance of any circuit that has been repaired or that has had any electrical components replaced. Adjustment of the circuit may be necessary.

CORRECTIVE MAINTENANCE

Corrective maintenance consists of component replacement and instrument repair. Special techniques required to replace components are given here.

OBTAINING REPLACEMENT PARTS

Most electrical and mechanical parts can be obtained through your local Tektronix Field Office or representative. However, many of the standard electronic components can be obtained locally. Before ordering or purchasing a part from a source other than Tektronix, Inc., check the electrical parts list for the proper value, tolerance, rating, and description.

Some parts are manufactured or selected by Tektronix, Inc. to satisfy particular requirements, or are manufactured for Tektronix, Inc. to our specifications.

NOTE

When selecting replacement parts, remember that the physical size and shape of a component may affect its performance in the instrument. All replacement parts should be direct replacements unless you know that a different component will not adversely affect instrument performance.

Most of the mechanical parts used in this instrument have been manufactured by Tektronix, Inc. To determine manufacturer of parts, refer to Parts List, Cross Index Mfr. Code Number to Manufacturer.

When ordering replacement parts from Tektronix, Inc., include the following information:

1. Instrument type.
2. Instrument serial number.
3. A description of the part (if electrical, include the circuit number, if crt, also include all data on crt tag).
4. Tektronix part number.

SOLDERING TECHNIQUES

WARNING

To avoid electric shock, disconnect the Monitor from the power source before soldering.

The reliability and accuracy of this instrument can be maintained only if proper soldering techniques are used when repairing or replacing parts. General soldering techniques which apply to maintenance of any precision electronic equipment should be used when working on

this instrument. Use only 60/40 resin-core, electric-grade solder. The choice of soldering iron is determined by the repair to be made. When soldering on circuit boards or small wiring, use only a 15-watt, pencil-type soldering iron. A higher wattage soldering iron can cause the etched circuit run to separate from the board base material and melt the insulation from small wiring. Always keep the soldering-iron tip properly tinned to ensure the best heat transfer to the solder joint. Apply only enough heat to remove the component or to make a good solder joint. To protect heat-sensitive components, hold the component lead between the component body and the solder joint with a pair of long-nose pliers or an alligator clip. Use a solder-removing wick to remove excess solder from connections or to clean circuit board pads.

The following technique should be used to replace a component on any of the circuit boards in this instrument. Most components can be replaced without removing the board(s) from the instrument.

1. Touch the soldering iron to the lead at the solder connection. Never place the iron directly on the board, as this may damage the board.

2. Melt a small amount of solder onto the component lead connection. This replaces the flux, which may have been removed during instrument cleaning, and facilitates removal of the component.

3. Grip the component lead with a pair of long-nose pliers. When the solder begins to flow, gently pull the component lead from the board. If unable to separate the lead from the board, try removing the other end of the component.

NOTE

Some components are difficult to remove from the circuit board due to a bend placed in each lead during machine insertion of the component. The purpose of the bent leads is to hold the component in position during a flow-solder manufacturing process which solders all components at once. To make removal of machine inserted components easier, straighten the leads of the component on the back of the circuit board using a small screwdriver or pliers, while heating the soldered connection.

4. Bend the leads of the replacement component to fit the holes in the circuit board. If the component is replaced while the board is mounted in the instrument, cut the leads so they will just protrude through the board. Insert the leads into the holes in the board so that the component is firmly seated against the board, or as originally positioned.

5. Touch the iron to the connection and apply enough solder to make a firm solder joint.

6. Cut off any excess lead protruding through the board (if not clipped in step 4).

7. Clean the area around the solder connection with a flux-removing solvent. Be careful not to remove information printed on the circuit board.

COMPONENT REMOVAL AND REPLACEMENT

WARNING

To avoid electric shock, always disconnect the Monitor from the power source before replacing components.

The exploded-view drawings associated with the Replaceable Mechanical Parts list (located at the rear of this manual) may be helpful in the removal or disassembly of individual components or sub-assemblies.

CATHODE-RAY TUBE REMOVAL

Remove the cathode-ray tube (crt) as follows (see Fig. 4-4):

WARNING

Use care when handling a crt. Breakage of the crt causes a high-velocity scattering of glass fragments (implosion). Protective clothing and safety glasses should be worn. Avoid striking the crt on any object which might cause it to crack or implode. When storing a crt, place it in a protective carton or set it face down in a protected location on a smooth surface with a soft mat under the faceplate.

1. Remove any protective side cabinet panels to gain access to the crt leads.

2. Disconnect 6 leads from the crt neck pins.

NOTE

The red and black leads exiting the crt shield to the X-Y Output Amplifier board are connected to the display-rotation coil inside the shield. They will not hamper crt removal and need not be disconnected.

3. Remove the 5 crt rear-cover securing screws and remove the cover.

4. Remove the crt base-pin socket.

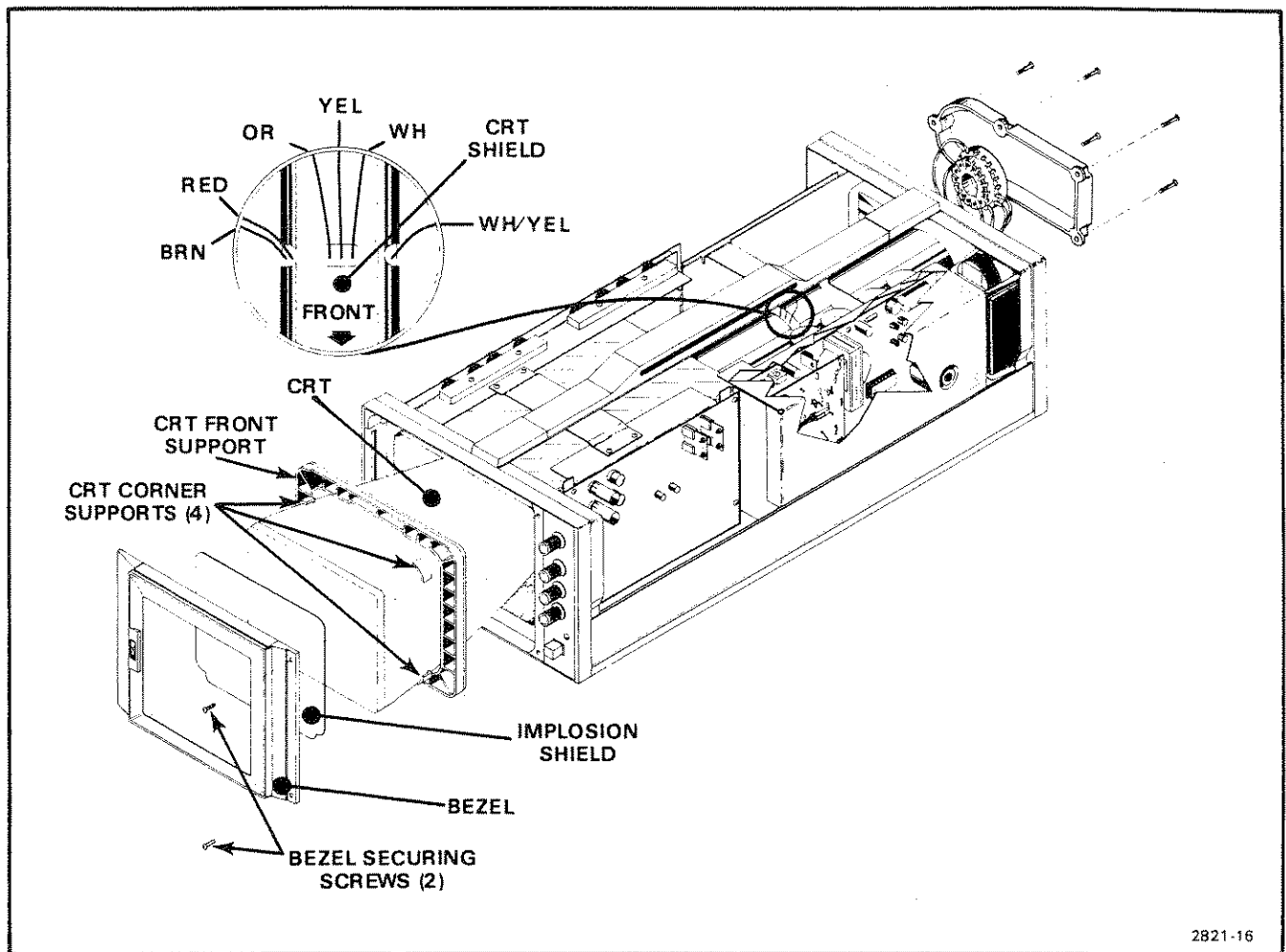

Figure 4-4. Crt removal.

5. Remove the bezel and snap-in implosion shield by removing the 2 bezel securing screws on the front of the instrument.

6. With one hand on the front of the instrument, gently push on the crt base to slide the crt forward. The crt front support will slide out with the crt.

7. Press the crt front support toward the rear of the crt. The corner supports will fall away.

2. Guide the neck of the crt into the shield.

3. Mount and fasten the bezel and implosion shield to the front panel with the 2 bezel securing screws.

NOTE

Align the extender shafts with the appropriate holes in bezel.

4. Place the crt base-pin socket onto the crt base pins.

5. Install the socket cover.

5. Position and secure the rear cover.

6. Connect the 6 leads to the proper crt neck pins.

NOTE

The replacement crt will require that the Monitor be readjusted. Refer to Section 5, Calibration.

CATHODE-RAY TUBE REPLACEMENT

Replace the cathode-ray tube (crt) as follows (see Fig. 4-4):

1. Install the front and corner supports on the crt.

CIRCUIT BOARD REPLACEMENT

If a circuit board is damaged beyond repair, the entire assembly, including all soldered-on components, can be replaced. Part numbers for the completely wired boards are given in Section 7, Replaceable Electrical Parts.

A1 X-Y Output Amplifier Board Removal

Remove the A1 X-Y Output Amplifier board as follows (refer to Figure 4-5):

1. Remove the shield.
2. Remove the 2 Transistor Retaining Blocks and 4 fish paper insulation strips.
3. Unsolder the 8 transistors, noting the location of each. (These transistors are not shipped as part of the board assembly.)

4. Unplug the 2-pin Harmonica, P290, and 4 individual pins connected to the crt deflection plates.

5. Position the instrument on its right side.

6. Remove 8 Transistor Retaining Screws, 1 board mounting screw, and 1 threaded spacer post.

7. Pry up (with fingers) on the board near the interboard connector. When the pins are completely disengaged pull the board to the rear until the extender shafts clear the bezel.

Install the A1 X-Y Output Amplifier board as follows (refer to Figure 4-5):

1. Align extender shafts with appropriate holes in bezel.
2. Fully engage the interboard connector.

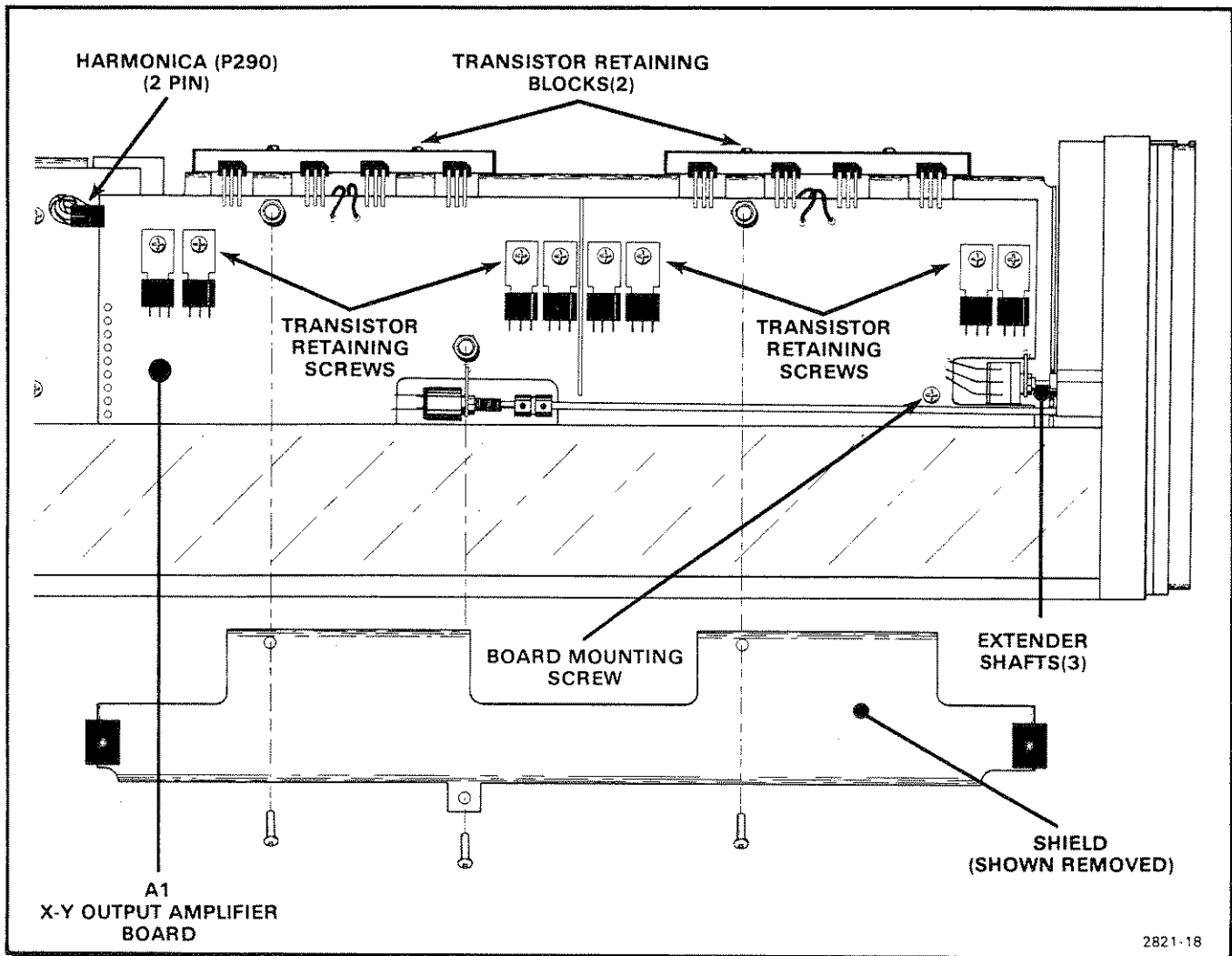

Figure 4-5. A1 X-Y Output Amplifier board removal.

3. Replace 1 Board Mounting Screw, 1 threaded spacer post and the 8 Transistor Retaining Screws. Leave loose.

4. Tighten all 9 screws and the spacer post.

5. Plug in the 2-pin Harmonica (P290) and the 4 individual crt neck pin connectors.

6. Solder in 8 transistors.

7. Position the fish paper insulation strips on both sides of the transistor mounting tabs. Align the holes in the Transistor Retaining Blocks with those in the fish paper insulation strips and the chassis. Secure the Transistor Retaining Blocks.

8. Snap the shield in place, then secure with 2 screws.

A2 X-Y Pre-Amplifier Board

Remove the X-Y Pre-amplifier board as follows (refer to Fig. 4-6):

1. Remove the small "L" shaped shield covering the upper edge of the X-Y Pre-Amplifier board.

2. Then remove the X-Y Output Amplifier board as previously described, however, do not unsolder the 8 transistors in step 3. Next, proceed with the following instructions.

3. Unplug the four 2-pin Harmonica connectors.

4. Remove 4 mounting screws.

5. Separate the interboard connector and pull the board from the instrument.

6. To replace the board, reverse the preceding removal procedure.

A3 Low-Voltage Power And Z-Axis Board

Remove the Low-Voltage Power and Z-Axis board as follows (refer to Figure 4-7):

1. Unplug the 10-pin Harmonica connectors (both ends of the ribbon cable).

2. Remove the High Voltage Shield.

3. Loosen the 2 screws securing the transistor heat sinks to the chassis.

4. Remove 2 Transistors mounted to the chassis by spring clips.

5. Remove the Voltage Selector Plug to gain access to the leads behind it.

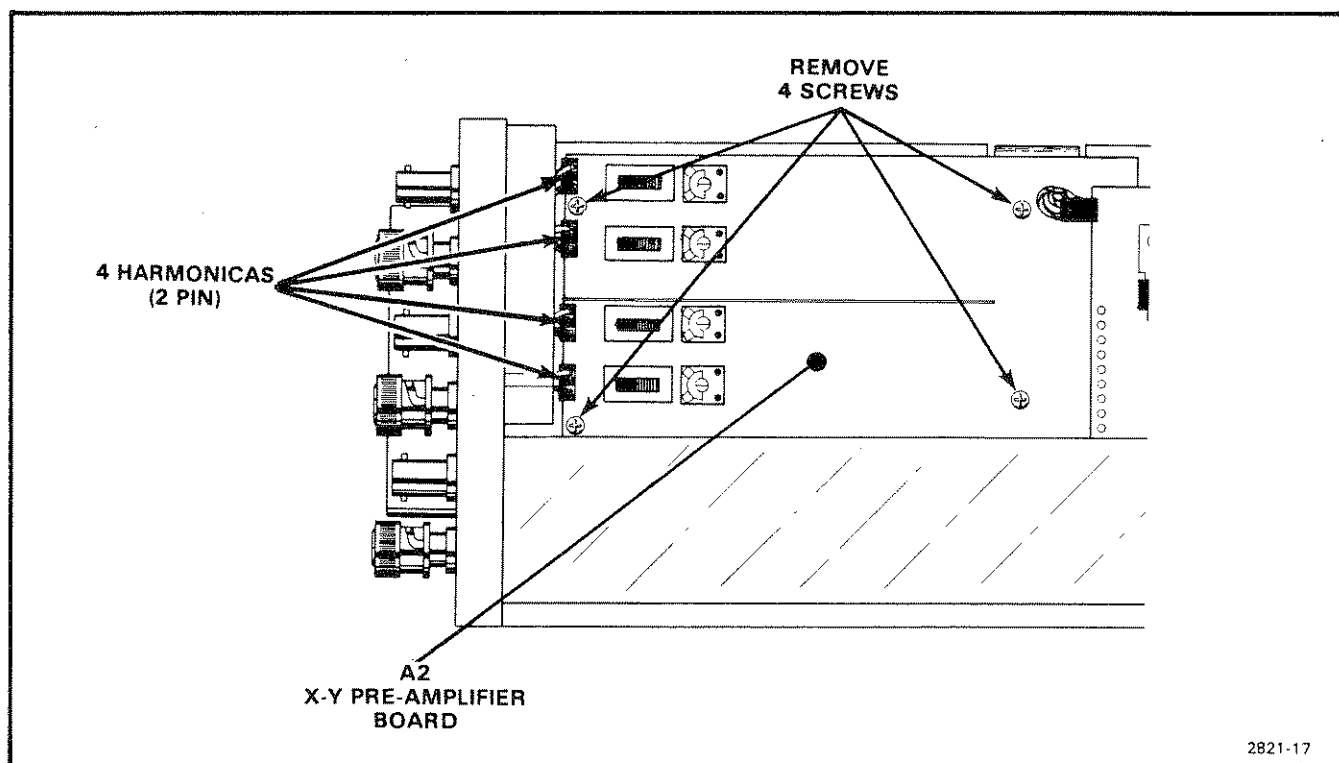

Figure 4-6. A2 X-Y Pre-Amplifier board removal.

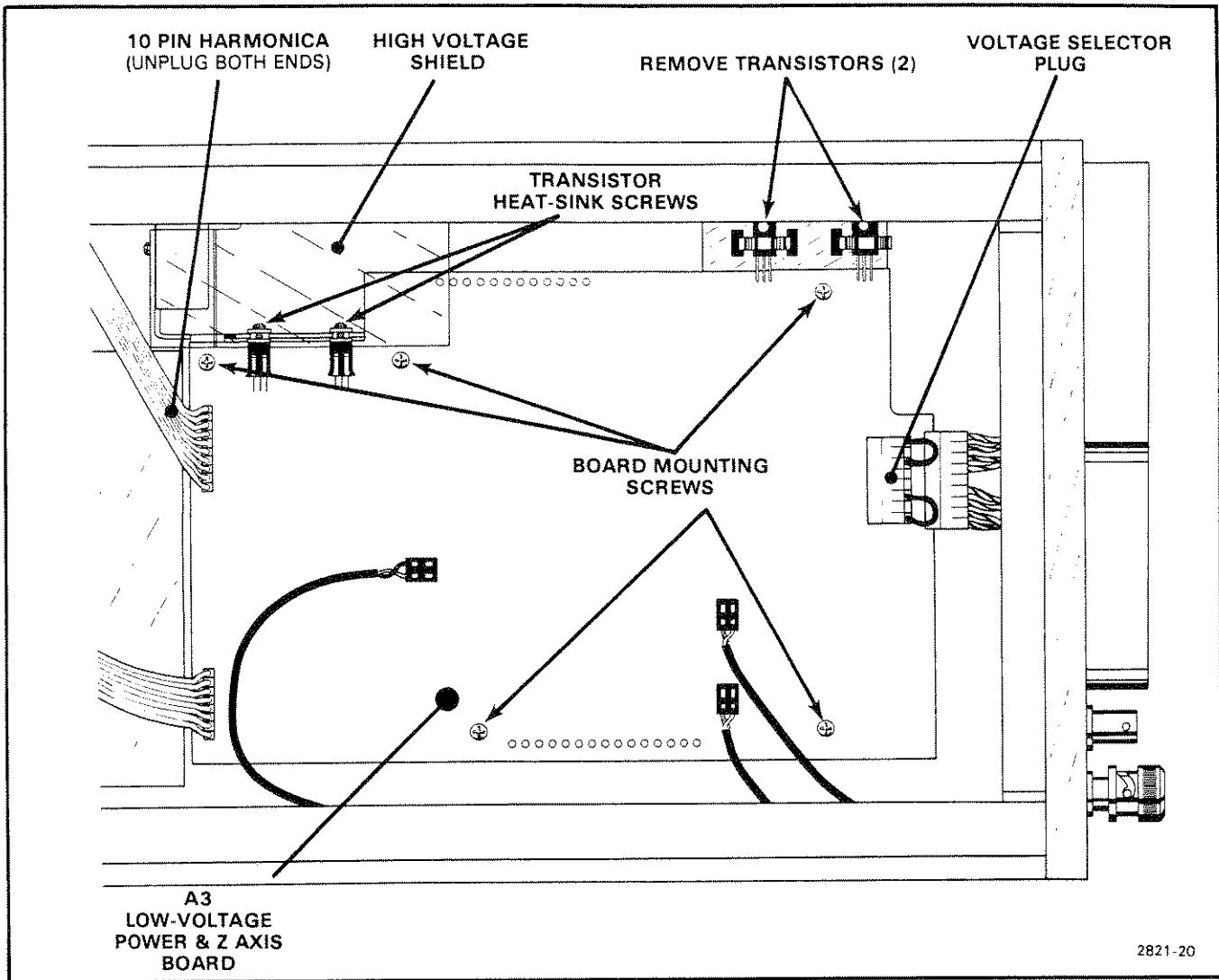

Figure 4-7. A3 Low Voltage Power and Z-Axis board removal.

6. Unsolder the 2 leads behind the Voltage Selector Plug and the 4 leads (2 black and 2 red) that come to the board from the transformer.

7. Remove the remaining 6 Harmonica connectors.

8. Remove 5 Board Mounting Screws.

9. Pry up on the board near the interboard connectors (2) while guiding the two heat sinks from their slots. (See step 3.)

10. Remove the board.

11. To install the board, reverse the removal procedure.

A4 Converter Board

Remove the Converter board as follows (refer to Fig. 4-8):

1. Follow the procedure for the High Voltage board removal (delete step 7), then proceed with the following instructions.

2. Remove the 2 transistor Spring Clips. Retain the white Insulating Chips (2) located between the transistors and the chassis.

3. Unplug the 2 single Harmonica connectors.

4. Remove 6 board-mounting screws.

5. Pry up on the board near the Interboard Connector.

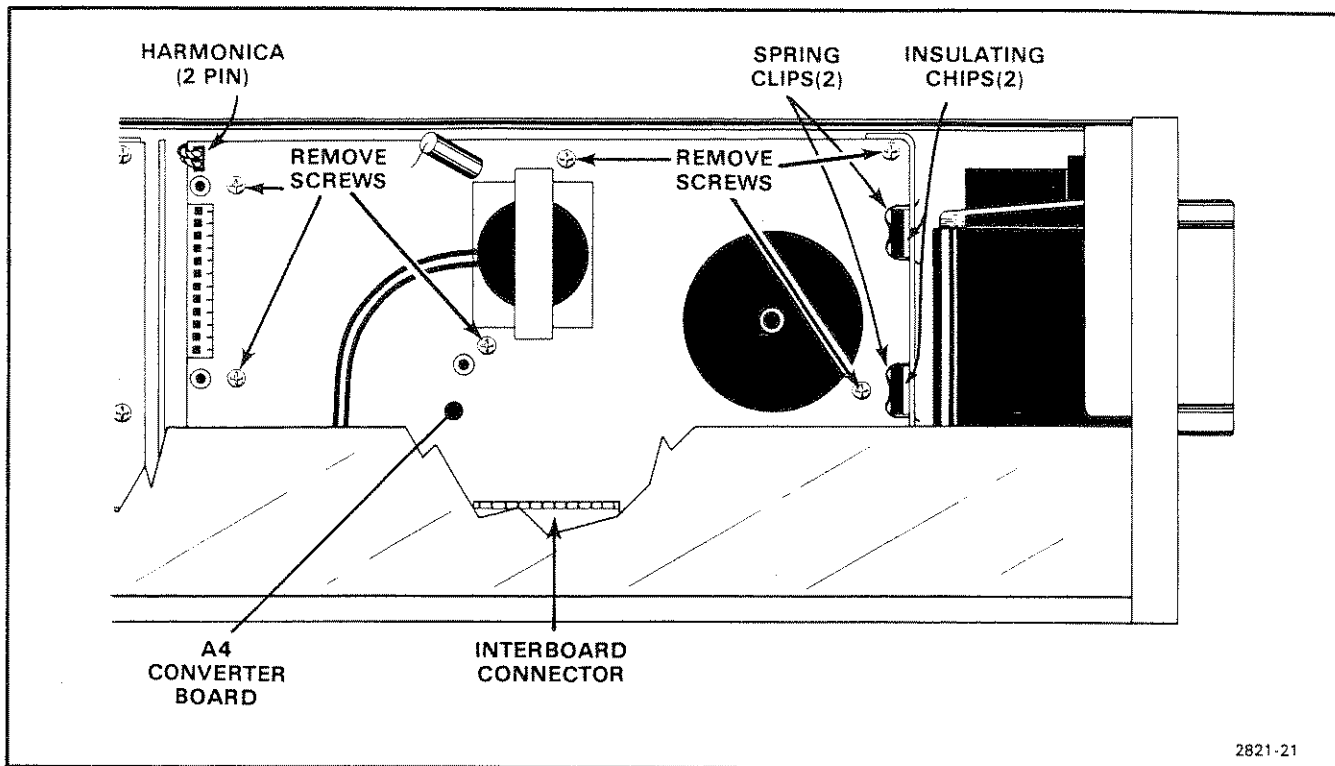

Figure 4-8. A4 Converter board removal.

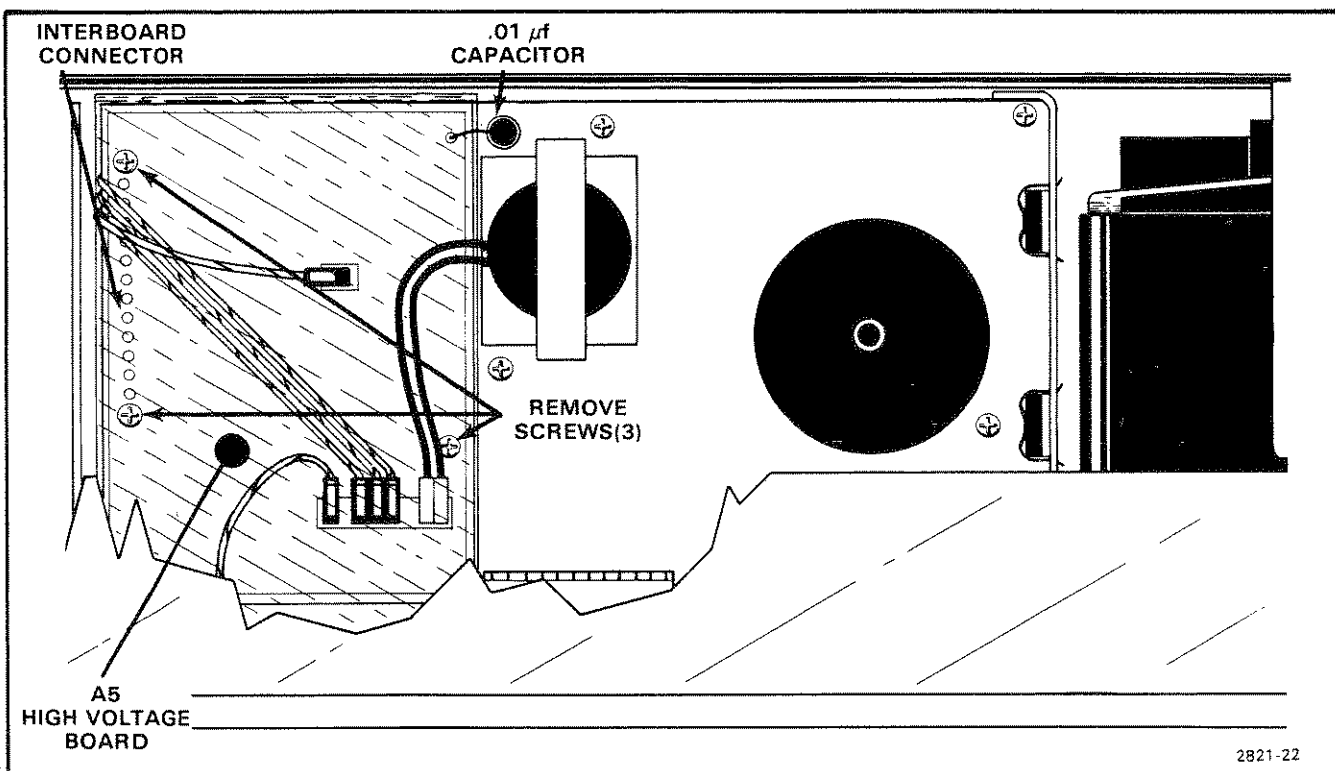

Figure 4-9. A5 High Voltage board removal.

6. Remove the board.

7. To install the board, reverse the removal procedure.

A5 High Voltage Board

Remove the High Voltage Board as follows (refer to Fig. 4-9):

1. Remove the metal shield (2 screws).
2. Remove the plastic high voltage shield (remove 3 nylon screws).
3. Unplug all harmonica connectors (4).
4. Unsolder the 0.01 μ F Capacitor from the High Voltage Board.
5. Pry up on the board near the Interboard Connector. Remove the board.
6. Remove the plastic (Lexan) shield from the board.

7. To install the board, reverse the removal procedure.

A6 Dynamic Focus Board

Remove the Dynamic Focus board as follows (refer to Fig. 4-10):

1. Remove the Plastic Shield
2. Unplug all harmonica connectors.
3. Remove the Transistor Retaining Block and insulating fish paper.
4. Remove 2 board-mounting screws and 2 Threaded Spacer Posts (3/16 wrench).
5. Remove the board.
6. To install the board, reverse the removal procedure.

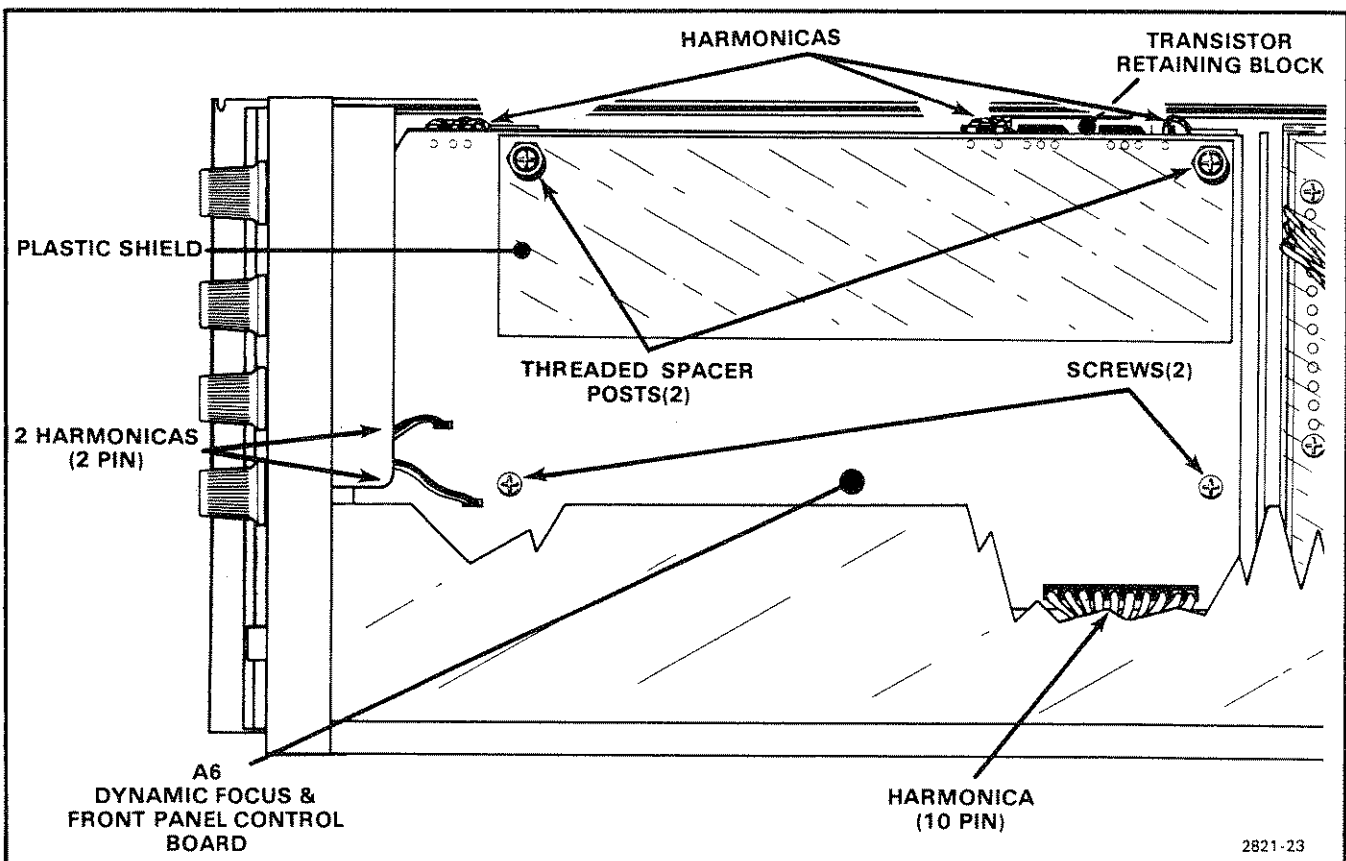

Figure 4-10. A6 Dynamic Focus and Front Panel Control board removal.

SEMICONDUCTORS

Semiconductors should not be replaced unless actually defective. If removed from their sockets during routine maintenance, return them to their original sockets. Unnecessary replacement of semiconductors may affect the adjustment of the instrument. When semiconductors are replaced, check the operation of circuits which may be affected.

WARNING

Always disconnect the Monitor from the power source before replacing components to avoid electrical-shock hazard.

Replacement semiconductors should be of the original type or a direct replacement. Lead configurations of the semiconductors used in this instrument are shown in Figure 4-2. Some plastic case transistors have lead configurations which do not agree with those shown. If a replacement transistor is made by a different manufacturer than the original, check the manufacturer's basing diagram for correct basing. All transistor sockets are wired for the standard basing as used for metal-cased transistors.

WARNING

Handle silicone grease with care. Avoid getting silicone grease in your eyes. Wash hands thoroughly after use.

When removing soldered-in transistors, use a solder-removing wick to remove the solder from the circuit board pads. Transistors which have heat radiators or are mounted on the chassis use silicone grease to increase heat transfer. Replace the silicone grease on both sides of the insulator plate and on the metal tab, if the transistor has one, when replacing these transistors.

INTERCONNECTING CIRCUIT-BOARD PIN REPLACEMENT

A circuit-board pin replacement kit, including necessary tools, instructions, and replacement pins with attached spare ferrules, is available from Tektronix, Inc. Order Tektronix Part 040-0542-00.

To replace a damaged pin, first disconnect any pin connectors. Then unsolder (see Soldering Techniques) the damaged pin and pull it from the board with a pair of pliers, leaving the ferrule (see Fig. 4-11) in the hole if possible. If the ferrule remains in the circuit board, remove the spare ferrule from the replacement pin and press the new pin into the hole in the circuit board. If the ferrule is removed with the damaged pin, clean out the hole using a solder-removing wick and a scribe. Then,

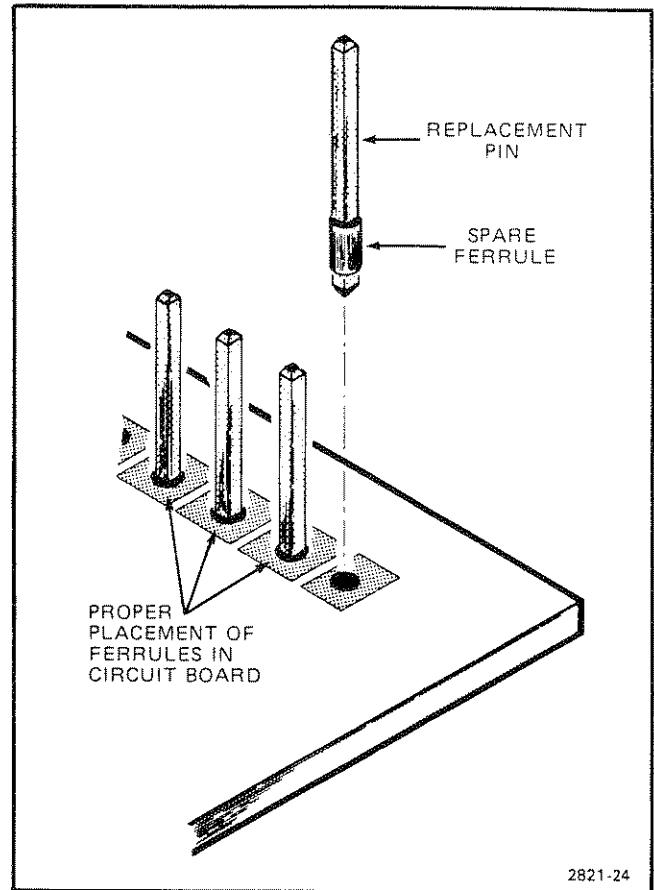

Figure 4-11. Exploded View of circuit board pin and ferrule.

press the replacement pin, with attached spare ferrule, into the hole. Position the replacement pin in the same manner as the original pin had been. Solder the pin to the circuit board on each side of the circuit board. If the original pin was bent at an angle to mate with a connector, carefully bend the new pin to the same angle. Replace the pin connector.

END-LEAD PIN CONNECTORS

The pin connectors used to connect the wires to the interconnecting pins are clamped to the ends of the associated leads. To remove or replace damaged end-lead pin connectors, remove the old pin connector from the end of the lead and clamp the replacement connector to the lead.

Some of the pin connectors are grouped and mounted in a plastic holder; the overall result is that these connectors are removed and installed as a multi-pin connector (see Troubleshooting Aids). If the individual end-lead pin connectors are removed from the plastic holder, note the order of the individual wires for correct replacement in the holder.

CALIBRATION

This section provides procedures for calibrating this instrument. These procedures are designed to compare the performance of this instrument with measurement instruments of known accuracy to detect, correlate, or eliminate by adjustment, any variation from the electrical specifications. These procedures also verify that the controls function properly.

This section is divided into two parts: Part I—Performance Check is provided for those who wish to verify that this instrument meets the applicable electrical specifications in section 1 without making internal adjustments. Part II—Adjustment and Performance Check provides a complete calibration procedure that includes adjustments and performance checks in addition to verifying that the controls function properly. The procedures in Part I and Part II are written so that the entire instrument, or any major circuit or part of a circuit, can be checked or adjusted.

Table 5-1, Calibration Procedure Electives, lists the choices available and instructions for performing complete or partial calibration procedures. Also refer to Using These Procedures, for more detailed information.

TABLE 5-1
Calibration Procedure Electives

Electives	Procedures
Functional Check	1. A functional check only is provided in the Checkout Procedure in section 2. 2. A functional check is also accomplished by performing Part II—Adjustment and Performance Check.
Performance Check Only	Perform Part I—Performance Check.
Complete Calibration	Perform Part II—Adjustment and Performance Check.
Partial Procedures	Proceed to the desired step(s) (e.g., A2, A3, B2, B3, etc.; as listed in the Index to part I—Performance Check or Index to Part II—Adjustment and Performance Check). <p style="text-align: center;">NOTE</p> <p style="text-align: center;"><i>When adjustments are made we recommend that the entire major functional circuit procedure be performed.</i></p>

USING THESE PROCEDURES

NOTE

In these procedures, capital letters are used within the body of the text to identify front-panel controls, indicators, and connectors on the 606B (e.g., FOCUS). Initial capitalization is used to identify all the associated test equipment and their controls, indicators, and connectors (e.g., Amplitude) used in the procedures. Initial capitalization is also used to identify internal adjustments of the 606B (e.g., X-Plate DC Level).

These procedures are divided into subsections by major functional circuits (e.g., A. Power Supplies, B. Crt, etc.). The order in which the subsections and procedures appear is the recommended sequence for a complete performance check or calibration of the instrument.

The first step in each subsection (A1, B1, C1, etc.) contains reference information and control settings that must be performed before proceeding.

The Setup Conditions provide equipment connection information and control settings for both this instrument and any associated test equipment. Also, the Setup Conditions are written so that if desired, each subsection (A, B, C, etc.) or step (A2, A3, B2, B3, etc.) can be performed independently.

The terms CHECK, EXAMINE, ADJUST, or INTERACTION when used as the first word of an instruction are defined as follows:

1. **CHECK**—indicates the instruction accomplishes an electrical specification check. Each electrical specification checked is listed in Table 5-2. Performance Check Summary (see the following Performance Check Summary discussion for more information).

2. **EXAMINE**—usually precedes an ADJUST instruction and indicates that the instruction determines whether adjustment is necessary. If no ADJUST instruction appears in the same step, the EXAMINE instruction concerns measurement limits that do not have a related adjustment. Measurement limits following the word EXAMINE are not to be interpreted as electrical specifications. They are provided as indicators of a properly functioning instrument and to aid in the adjustment process.

3. **ADJUST**—describes which adjustment to make and the desired result. We recommend that adjustments not be made if a previous CHECK or EXAMINE instruction indicates that no adjustment is necessary.

4. **INTERACTION**—indicates that the adjustment described in the preceding instruction interacts with other circuits. The nature of the interaction is described and reference is made to the step(s) affected.

PERFORMANCE CHECK SUMMARY

Table 5-2, Performance Check Summary, lists the electrical specifications that are checked in Part I and Part II of this section. Table 5-2 is intended to provide a convenient means for locating the procedures in Part I and Part II that check and/or adjust the instrument to meet the applicable electrical specifications. For example: if the Z-Axis Amplifier had been repaired, use Table 5-2 to locate the electrical specifications affected by the repair. Then note the title of the procedure in Part I or Part II in which those specifications are checked and/or adjusted. Use the index provided at the front of Part I and Part II to determine the page number of the desired procedures.

TABLE 5-2
Performance Check Summary

Characteristic	Performance Requirement	Part I Performance Check Procedure Title	Part II Adjustment and Performance Check Procedure Title
----------------	-------------------------	--	---

POWER SOURCE

LO Line Voltage Range		Does not normally require customer verification.	
L (100 V ac)	90 to 110 V ac.		
M (110 V ac)	99 to 121 V ac.		
H (120 V ac)	108 to 132 V ac.		

TABLE 5-2 (CONT)
Performance Check Summary

Characteristic	Performance Requirement	Part I Performance Check Procedure Title	Part II Adjustment and Performance Check Procedure Title
HI Line Voltage Range		Does not normally require customer verification.	
L (200 V ac)	180 to 220 V ac.		
M (220 V ac)	198 to 242 V ac.		
H (240 V ac)	216 to 250 V ac.		
Line Frequency	48 to 440 Hz.		
Power Consumption			
Maximum	75 W, 120 V ac, 60 Hz.		
Nominal	50 W, 120 V ac, 60 Hz.		

CATHODE-RAY TUBE

Quality Area	7 × 9 cm.	Does not normally require customer verification.	
Geometry	Bowing or tilt 1 mm or less over the full screen.	B3. Check Geometry (R185).	B4. Check/Adjust Geometry (R185).
Orthogonality	90° within 0.7°.	B2. Check Orthogonality.	B3. Check Orthogonality.
Compression and Expansion	Less than 1% of full screen deflection.	Does not normally require customer verification.	
Spot Diameter	0.079 cm (0.0031 in.) or less, with intensity set for 3.45 $\mu\text{W}/\text{cm}^2$ (P31), 700 line, 7 × 9 cm focused raster. Measured with the shrinking raster method. (125 lines/cm, center screen).	F2. Check Spot Diameter.	F5. Check Spot Diameter.
Spot Shape	Measured within the quality area. The ratio between two perpendicular spot crosssections does not exceed 1.5:1.	Does not normally require customer verification.	
Spot Growth	Not greater than 20% at constant intensity within the quality area.		
Light Output	Greater than 20 $\mu\text{W}/\text{cm}^2$ with a 700 line 60 Hz refresh raster, with a 100% duty cycle, at maximum allowable drive to the crt, over a 7 × 9 cm area.		

TABLE 5-2 (CONT)
Performance Check Summary

Characteristic	Performance Requirement	Part I Performance Check Procedure Title	Part II Adjustment and Performance Check Procedure Title
HORIZONTAL (X) AMPLIFIER			
Deflection Factor	Internally adjustable from 0.5 V to 2.5 V for 8 divisions of deflection. Externally adjustable for at least $\pm 10\%$ of nominal.	C2. Check Positioning and Gain.	C3. Adjust X Amplifier Gain and Check Positioning.
Input Attenuators	Allows a 5X increase in deflection factor.	C5. Check Horizontal Input Attenuation.	C7. Check Horizontal Input Attenuation.
Polarity	+Signal deflects beam to the right, -Signal deflects beam to the left.	Does not normally require customer verification.	
Bandwidth	Dc to at least 3 MHz at -3 dB point.	C4. Check Horizontal Bandwidth.	C6. Check Horizontal Bandwidth.
Settling Time		C3. Check Horizontal Settling Time.	C5. Check Horizontal Settling Time.
After deflection between any 2 points on screen	Spot must reach new writing position, within 0.008 cm (0.003 inch), within 500 ns.		
After deflection to any point on screen from within 20 cm of screen center.	Spot must reach new writing position, within 0.008 cm (0.003 inch), within 700 ns.		
Risetime	116 nsec or less.	Does not normally require customer verification. However, risetime can be calculated from the Horizontal Bandwidth.	
Common Mode Rejection		C6. Check Horizontal Common-Mode Rejection.	C8. Check Horizontal Common-Mode Rejection.
Atten in X1 Position			
DC to 500 kHz	At least 100:1 for signals of ± 3 V peak, or less.		
500 kHz to 1 MHz	At least 40:1 for signals of ± 15 V peak, or less.		
Atten in X5 Position			
DC to 500 KHz	At least 40:1 for signals of ± 15 V peak, or less.		

TABLE 5-2 (CONT)
Performance Check Summary

Characteristic	Performance Requirement	Part I Performance Check Procedure Title	Part II Adjustment and Performance Check Procedure Title
Maximum Non-Destructive Input Voltage (fault condition only)	1 M Ω input impedance: +100 V or -100 V dc + peak ac. 50 Ω input impedance: +15 V or -5 V dc + peak ac.	Specification applicable under fault condition only; therefore this is not a procedural check.	
Position Range	Spot can be positioned anywhere on the screen.	C2. Check Positioning and Gain.	C3. Adjust X Amplifier Gain and Check Positioning.
Position Stability	0.1 cm or less drift per hr. after 20 minute warmup.	Does not normally require customer verification.	
Gain Stability	Less than 1% change under all conditions of line voltage and temperature.		
Crosstalk Between X and Y Amplifiers	0.005 cm (0.002 inch) or less of deflection on the undriven channel with full screen amplitude of 1 MHz sine wave applied to the other channel. Other inputs grounded or terminated into 50 ohms.		
From Z to X Amplifier	0.012 cm (0.005 inch) or less of deflection on the undriven channels when the Z-Axis Amplifier is driven for a 70 V output with a 1 MHz sine wave. X and Y inputs grounded or terminated into 50 ohms.		

VERTICAL (Y) AMPLIFIER

Deflection Factor	Internally adjustable from 0.5 V to 2.5 V for 8 divisions of deflection. Externally adjustable for at least $\pm 10\%$ of nominal.	D2. Check Positioning and Gain.	D2. Adjust Y Amplifier Gain and Check Positioning.
Input Attenuators	Allows a 5X increase in deflection factor.	D5. Check Vertical Input Attenuation.	D6. Check Vertical Input Attenuation.

TABLE 5-2 (CONT)
Performance Check Summary

Characteristic	Performance Requirement	Part I Performance Check Procedure Title	Part II Adjustment and Performance Check Procedure Title
Polarity	+Signal deflects beam to the right, -Signal deflects beam to the left.	Does not normally require customer verification.	
Bandwidth	Dc to at least 3 MHz at -3 dB point.	D4. Check Vertical Bandwidth.	D5. Check Vertical Bandwidth.
Settling Time		D3. Check Vertical Settling Time.	D4. Check Vertical Settling Time.
After deflection between any 2 points on screen	Spot must reach new writing position, within 0.008 cm (0.003 inch), within 500 ns.		
After deflection to any point on screen from within 10 cm of screen center.	Spot must reach new writing position, within 0.008 cm (0.003 inch), within 700 ns.		
Phase Difference (Dc to 500 kHz)	1° or less between X and Y amplifiers.	D7. Check Phasing.	D8. Check Phasing.
Risetime	116 nsec or less.	Does not normally require customer verification. However, risetime can be calculated from the Horizontal Bandwidth.	
Common Mode Rejection		D6. Check Vertical (Y) Common-Mode Rejection.	D7. Check Vertical (Y) Common-Mode Rejection.
Atten in X1 Position			
DC to 500 kHz	At least 100:1 for signals of ±3 V peak, or less.		
500 kHz to 1 MHz	At least 40:1 for signals of ±15 V peak, or less.		
Atten in X5 Position			
DC to 500 kHz	At least 40:1 for signals of ±15 V peak, or less.		
Maximum Non-Destructive Input Voltage (fault condition only)	1 MΩ input impedance: +100 V or -100 V dc + peak ac. 50 Ω input impedance: +5 V or -5 V dc + peak ac.	Specification applicable under fault condition only; therefore this is not a procedural check.	
Position Range	Spot can be positioned anywhere on the screen.	D2. Check Positioning and Gain.	D2. Adjust Y Amplifier Gain and Check Positioning.

TABLE 5-2 (CONT)
Performance Check Summary

Characteristic	Performance Requirement	Part I Performance Check Procedure Title	Part II Adjustment and Performance Check Procedure Title
Dynamic Range	At least +1.5 screen diameters from screen center (± 10 cm).	Does not normally require customer verification.	
Position Stability	0.1 cm or less drift per hr. after 20 minute warmup.		
Gain Stability	Less than 1% change under all conditions of line voltage and temperature.		
Crosstalk Between X and Y Amplifiers	0.005 cm (0.002 inch) or less of deflection on the undriven channel with full screen amplitude of 1 MHz sine wave applied to the other channel. Other inputs grounded or terminated into 50 Ω .		
From Z to Y Amplifier	0.012 cm (0.005 inch) or less of deflection on the undriven channels when the Z-Axis Amplifier is driven for a 70 V output with a 1 MHz sine wave. X and Y inputs grounded or terminated into 50 Ω .		

Z AXIS AMPLIFIER

Gain Range	Internally adjustable to allow 0.5 V to 2.5 V at the input connector to generate maximum allowable voltage swing at the crt control grid. (0 V to 70 V).	Does not normally require customer verification.	
Bandwidth	Dc to 5 MHz at -3 dB point.	E3. Check Z-Axis Amplifier Bandwidth.	E4. Check Z-Axis Amplifier Bandwidth.
Risetime	35 ns or less.	Does not normally require customer verification.	
Aberration	5% or less.	E2. Check Aberrations.	E3. Adjust Z-Axis Compensation and Check Aberrations.

TABLE 5-2 (CONT)
Performance Check Summary

Characteristic	Performance Requirement	Part I Performance Check Procedure Title	Part II Adjustment and Performance Check Procedure Title
Common Mode Rejection Dc to 100 kHz	At least 100:1 with input signals up to 5 V p-p at any gain setting.	E4. Check Z-Axis Common-Mode Rejection.	E5. Check Z-Axis Common-Mode Rejection.
Input Impedance	1 MΩ within 1%, or 50 Ω within 1%; paralleled by 47 pF or less.	Does not normally require customer verification.	
Maximum Non-Destructive Input Voltage (fault condition only)	1 MΩ input impedance: +100 V dc + peak ac. 50 Ω input impedance: +5 V or -5 V dc + peak ac.		
TTL Input	Logic input blanks or unblanks Crt to level set by front panel INTENSITY control and Z-axis input voltage.	E5. Check Z-Axis Blanking.	E6. Check Z-Axis Blanking.
HI	+2.4 to +5 V.		
LO	0 V to +0.8 V.		

ADJUSTMENT INTERVAL

To maintain instrument accuracy, check performance every 1000 hours of operation, or every 6 months if used infrequently. Before complete adjustment, thoroughly clean and inspect this instrument as outlined in the Maintenance section.

TEKTRONIX FIELD SERVICE

Tektronix Field Service Centers and the Factory Service Center provide instrument repair and adjustment services. Contact your Tektronix Field Office or representative for further information.

TEST EQUIPMENT REQUIRED

The test equipment listed in Table 5-3 is required for a complete Adjustment and Performance Check of the instrument. If only a Performance Check is to be performed, the items required for Adjustment are not required and are indicated by footnote 1. The remaining test equipment is common to both procedures.

The specifications for test equipment, given in Table 5-3 are the minimum required to meet the performance requirements. Detailed operating instructions for test equipment are omitted in these procedures. Refer to the test equipment instruction manual if more information is needed.

SPECIAL FIXTURES

Special fixtures are used only where they facilitate instrument adjustment. These fixtures are available from Tektronix, Inc. Order by part number from Tektronix Field Offices or representatives.

TEST EQUIPMENT ALTERNATIVES

All of the listed test equipment is required to completely calibrate this instrument. However, complete checking or adjusting may not always be necessary or desirable. You may be satisfied with checking only selected characteristics, thereby reducing the amount of test equipment actually required.

The calibration procedures in Part I and Part II are based on the first item of equipment given as an example. When other equipment is substituted, control settings or setups may need to be altered. If the exact item of equipment given as an example in Table 5-3 is not available, first check the Minimum Specifications column carefully to see if any other equipment might suffice. Then check the Purpose column to see what this item is used for. If used for a performance check or adjustment that is of little or no importance for your measurement requirements, the item and corresponding step(s) can be deleted.

TABLE 5-3
Test Equipment

Description	Minimum Specifications	Purpose	Examples of Applicable Test Equipment
1. DVM (Digital Voltmeter) (with test leads)	Measurement range, -15 V to +250 V.	Check/adjust low voltage supplies. Check/adjust X Output DC Level. Adjust bias (R306, dynamic focus) Crt grid bias (R245). Check spot diameter.	a. TEKTRONIX DM 501A Option 02 Digital Multi-Meter (operates in TM 500-series power module). b. TEKTRONIX 7D13 Digital Multi-Meter (operates in 7000-series mainframe). c. TEKTRONIX DM 502A Option 02 Multi-Meter (operates in TM-500 series power module).
2. DC Voltmeter (with test leads)	Measurement range, -5450V to -5350V dc.	Check/adjust -5400 V supply.	a. Triplet Model 630-NA. b. Simpson Model 262.
3. Ramp Generator (2 required)	Ramp duration, 5 ms to 100 μ s within 3%; ramp amplitude, 0.5 to 2 V into 1 M Ω ; external trigger input, compatible with square-wave generator trigger output; gate output, 1 to 3 V into 1 M Ω .	Adjust gain and compensation of the vertical, horizontal, and Z-axis amplifiers. Check vertical and horizontal, bandwidth, common mode rejection and settling time. Check vertical and horizontal positioning. Adjust TRACE ALIGN and geometry. Check Orthogonality and Waveforms for Dynamic focus circuit.	a. TEKTRONIX RG 501 Ramp Generator (operates in TM 500-series power module).
4. Calibration Generator (Square-wave Generator)	Amplitude Calibrator Mode: Frequency, approx. 1 kHz; amplitude, 0.5V to 10V into 2 M Ω ; within 0.25%. Pulse Mode: High-Amplitude Output; Freq- 1 kHz to 100 kHz; amplitude, 0.5V to 10V into 50 Ω ; risetime, 10 ns or less into 50 Ω .	Adjust gain and compensation of the vertical, horizontal, and Z-axis amplifiers. Check vertical and horizontal settling time. Check and adjust vertical and horizontal input attenuators.	a. TEKTRONIX PG 506 Calibration Generator (operates in TM 500-series power module).

TABLE 5-3 (CONT)
Test Equipment

Description	Minimum Specifications	Purpose	Examples of Applicable Test Equipment
5. Sine-wave Generator	Frequency range, 500 kHz to at least 5 MHz; reference frequency, 50 kHz; amplitude, 0.5V to 5V into 50 Ω ; amplitude accuracy, constant within 5% of reference as output frequency changes.	Check common-mode rejection and bandwidth of the horizontal (X), vertical (Y), and Z-Axis amplifiers.	a. TEKTRONIX SG 503 Leveled Sine-Wave Generator (operates in TM 500-series power module).
6. Dot Generator	Provides dot-raster display; frame rate, at least 45 frames/second.	Adjust focus and stigmators. (An alternative method is provided which does not require a dot generator.	a. TEKTRONIX 067-0845-00 Dot Generator (operates in TM 500-series power module). b. TEKTRONIX 067-0561-01 Test Display Generator Calibration Fixture.
7. Power Module Mainframe (TM 500-series)	Capable of powering and housing 3 to 6 TM 500-series test instruments.	Provide housing and power for TM 500-series test signal generators and precision dc volt-meter.	a. TEKTRONIX TM 503, TM 504 or TM 506 Power Module.
8. Digital Counter	Dual channels, separate inputs (A, B). Measurement of ratio of A/B averaged over 10^5 cycles of B. AC coupling.	Check spot diameter.	a. TEKTRONIX DC 503 Universal Counter (operates in TM 500-series power module).
9. Test Oscilloscope (with 10X probe)	Bandwidth, dc to at least 50 MHz; deflection factor 0.1 to 20 V/div within 2%; sweep rate, 1 ms to 10 μ s/div.	Check/adjust Z-axis gain, compensation, bandwidth and common-mode rejection. Adjust focus and stigmators.	a. TEKTRONIX 7904 Oscilloscope, 7B92 time base and 7A13 Differential Comparator with P6063A 10X probe. b. TEKTRONIX 7603 Oscilloscope, 7A15A Amplifier, 7B50A Time Base and P6063A 10X probe. c. Refer to Tektronix catalog for compatible oscilloscope system.
10. Function Generator	Waveshape, sine; Frequency range, 500 kHz to 1 MHz amplitude 0-15 V (p-p).	Check horizontal, vertical, and Z-axis common-mode rejection. Check Z-axis blanking.	a. TEKTRONIX FG 503 Function Generator (operates in TM 500-Series power module).
11. Dual-input Coupler	Connectors, bnc.	Check/adjust horizontal (X), vertical (Y), and Z-axis common-mode rejection and blanking, horizontal and vertical phasing, attenuation compensation and check spot diameter.	a. TEKTRONIX 067-0525-01 Calibration Fixture.
12. 50-ohm Terminator	Impedance, 50 Ω ; connectors, bnc.	Adjust Z-axis gain, check Z-axis common-mode rejection.	a. TEKTRONIX part 011-0049-01.

TABLE 5-3 (CONT)
Test Equipment

Description	Minimum Specifications	Purpose	Examples of Applicable Test Equipment
13. 5X Attenuator	5X, 50 Ω , 2 W.	Checkout procedure.	a. TEKTRONIX part 011-0060-02.
14. 10X Attenuator	10X, 50 Ω , 2 W.	Check Z-axis blanking.	a. TEKTRONIX part 011-0059-02.
15. 50-ohm cables (4 required)	Impedance, 50 Ω ; length, 42 inches; connectors, bnc.	Provide signal inter-connection.	a. TEKTRONIX part 012-0057-01.
16. Screwdriver	3/32-inch bit.	Front panel screwdriver adjustments.	a. XCELITE R3323.
17. Low-capacitance Screwdriver	Double blade, 3/64 and 7/64-inch. Total length 4-3/8 inches.	Adjust variable capacitors, and internal variable resistors.	a. TEKTRONIX part 003-0675-01.
18. Screwdriver (insulated-with metal tip)	7/32-inch bit.	Adjust internal variable resistors.	a. TEKTRONIX part 003-0000-00. b. TEKTRONIX part 003-0374-00.
19. T Connector	Connectors, bnc-to-bnc.	Checkout procedure.	a. TEKTRONIX part 103-0030-00.
20. Variable AC Power Supply	90 V to 120 V.	Adjust Freq. (R124)	a. General Radio W8MT3VM Variac Autotransformer.
21. 9X Magnifier	5X to 10X magnification.	Adjust X and Y amplifier compensation, settling time. Adjust stigmators.	a. Edmund Scientific Co. model no. 30224, 9X Magnifier.
22. 24X Magnifier	15X to 30X magnification.	Check spot diameter.	a. Southern Precision model no. 1836, 6X used with aux 4X eyepiece. (Comes standard with 10X eyepiece.)

PART I—PERFORMANCE CHECK

The following procedure (Part I—Performance Check) verifies electrical specifications without making internal adjustments. All tolerances given are as specified in the Specification tables (section 1) in this manual.

Part II—Adjustment and Performance Check provides the information necessary to: (1) verify that the instrument meets the electrical specifications, (2) verify that the controls function properly, and (3) perform all internal adjustments.

A separate Checkout Procedure is provided in section 2 to provide instrument familiarization and to verify that the controls function properly.

See Table 5-1, Calibration Procedure Electives, at the beginning of this section, for information on performing a Partial Part I—Performance Check procedure.

INDEX TO PART I— PERFORMANCE CHECK

	PAGE
A. POWER SUPPLIES	5-13
B. CRT	5-14
1. Crt Preliminary Setup	5-14
2. Check Orthogonality	5-14
3. Check Geometry	5-14
C. HORIZONTAL (X) AMPLIFIER	5-15
1. Horizontal (X) Amplifier Preliminary Setup	5-15
2. Check Positioning and Gain	5-15
3. Check Horizontal Settling Time	5-16
4. Check Horizontal Bandwidth	5-16
5. Check Horizontal Input Attenuation	5-17
6. Check Horizontal (X) Common Mode Rejection (1X, 5X Atten)	5-17
D. VERTICAL (Y) AMPLIFIER	5-19
1. Vertical (Y) Amplifier Preliminary Setup	5-19
2. Check Positioning and Gain	5-19
3. Check Vertical Settling Time	5-20
4. Check Vertical Bandwidth	5-20
5. Check Vertical Input Attenuation	5-21
6. Check Vertical (Y) Common Mode Rejection (1X, 5X Atten)	5-21
7. Check Phasing	5-22
E. Z-AXIS AMPLIFIER	5-23
1. Z-Axis Amplifier Preliminary Setup	5-23
2. Check Aberrations	5-23
3. Check Z-Axis Amplifier Bandwidth	5-24
4. Check Z-Axis Common Mode Rejection	5-24
5. Check Z-Axis Blanking	5-25
F. DYNAMIC FOCUS	5-26
1. Dynamic Focus Preliminary Setup	5-26
2. Check Spot Diameter	5-26

PERFORMANCE CHECK POWER-UP SEQUENCE

NOTE

The performance of this instrument can be checked at any ambient temperature from 0° to +50° C unless otherwise stated. Adjustments must be performed at an ambient temperature from +15° to +25° C for specified accuracies.

1. Remove any cabinet panels to gain access to the internal controls, selectors and test points.
2. Check that the internal Line Voltage Selector plug has been set to the appropriate line voltage and range. (See Fig. 1-1 of Section 1, General Information).
3. Check the rear panel to determine which options have been installed in your Monitor.
4. Check that grounding caps are on the -INPUTs.
5. Check that the Input Impedance Selecting jumpers for the X and Y Amplifiers are in the 50 Ω position.
6. Check that the crt has an implosion shield with 8 × 10 division graticule.
7. Connect the Monitor and appropriate test equipment to the power source.
8. Set 606B INTENSITY to midrange.

CAUTION

Do not allow a high-intensity dot to remain stationary on the crt. The crt phosphor could be permanently damaged.

9. Switch on the Monitor and appropriate test equipment and allow at least 20 minutes warmup before proceeding.

A. POWER SUPPLIES

There are no performance checks for the Power Supplies.

B. CRT

Equipment Required: (Numbers correspond to those listed in Table 5-3, Test Equipment.)

- | | |
|--------------------------------|-----------------------------------|
| 1. DVM (Digital Voltmeter) | 15. 50-ohm bnc cable (1 required) |
| 3. Ramp Generator (1 required) | |

B1. CRT PRELIMINARY SETUP

a. Perform the Performance Check Power-Up Sequence given at the beginning of Part I—Performance Check.

b. Refer to Section 6, Instrument Options, and the Change Information at the rear of this manual for any modifications which may affect this procedure.

c. See **TEST POINT AND ADJUSTMENT LOCATIONS** and **INTERNAL CONTROL AND SELECTOR LOCATIONS** foldout pages in Section 8, Diagrams and Circuit Board Illustrations.

d. Set 606B controls:

INTENSITY Visible display
Vertical and Horizontal Position Midrange
FOCUS Well-defined display

a. Position the trace to the center vertical graticule line.

b. **CHECK**—That the vertical trace is aligned with the center vertical graticule line at the top and bottom of the graticule within 0.1 division.

B3. CHECK GEOMETRY

NOTE

If the preceding step was not performed, first perform Step B1, then proceed.

B2. CHECK ORTHOGONALITY

NOTE

Perform step B1, then proceed.

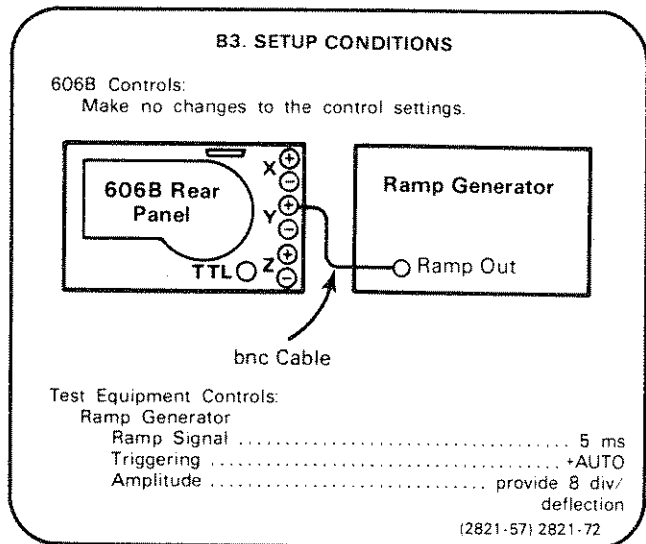
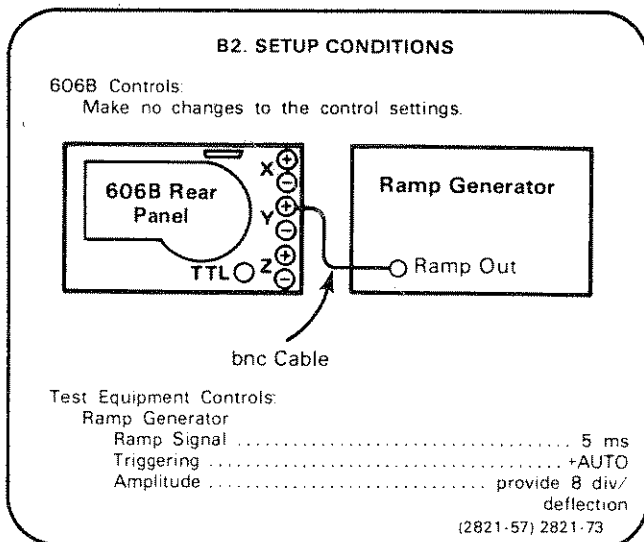

a. Position the trace to the left edge of the graticule, and then to the right edge.

b. **CHECK**—the vertical trace for 0.1 division or less of bowing at the left and right edges of the graticule.

C. HORIZONTAL (X) AMPLIFIER

Equipment Required: (Numbers correspond to those listed in Table 5-3, Test Equipment).

- | | |
|---------------------------------------|-----------------------------|
| 1. DVM (Digital Voltmeter) | 10. Function Generator |
| 3. Ramp Generator | 11. Dual Input Coupler |
| 4. Calibration Generator | 15. bnc cables (3 required) |
| 5. Sine Wave Generator | |
| 9. Test Oscilloscope (with 10X probe) | |

C1. HORIZONTAL (X) AMPLIFIER PRELIMINARY SETUP

a. Perform the Performance Check Power-Up Sequence given at the beginning of Part I—Performance Check.

b. Refer to Section 6, Instrument Options, and the Change Information at the rear of this manual for any modifications which may affect this procedure.

c. See **TEST POINT AND ADJUSTMENT LOCATIONS** and **INTERNAL CONTROL AND SELECTOR LOCATIONS** foldout pages in Section 8, Diagrams and Circuit Board Illustrations.

d. Set 606B Controls:

INTENSITY Visible display
Vertical and Horizontal Position..... Midrange
FOCUS..... Well-defined display

C2. CHECK POSITIONING AND GAIN

NOTE

Perform step C1, then proceed.

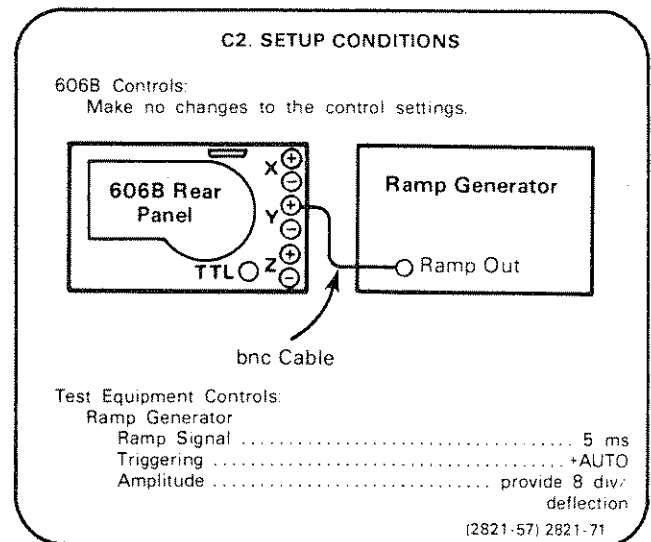

a. **CHECK**—Rotate the horizontal Position control and check that the vertical trace can be positioned horizontally anywhere in the graticule area.

b. Disconnect the Ramp Generator for the +Y INPUT and apply the ramp to the test Oscilloscope vertical input. Set Volts/Div. switch to 1 V position (with 10X probe).

c. **CHECK**—For a 1-division display on the test Oscilloscope.

C3. CHECK HORIZONTAL SETTLING TIME

NOTE

If the preceding step was not performed, first perform step C1, then proceed.

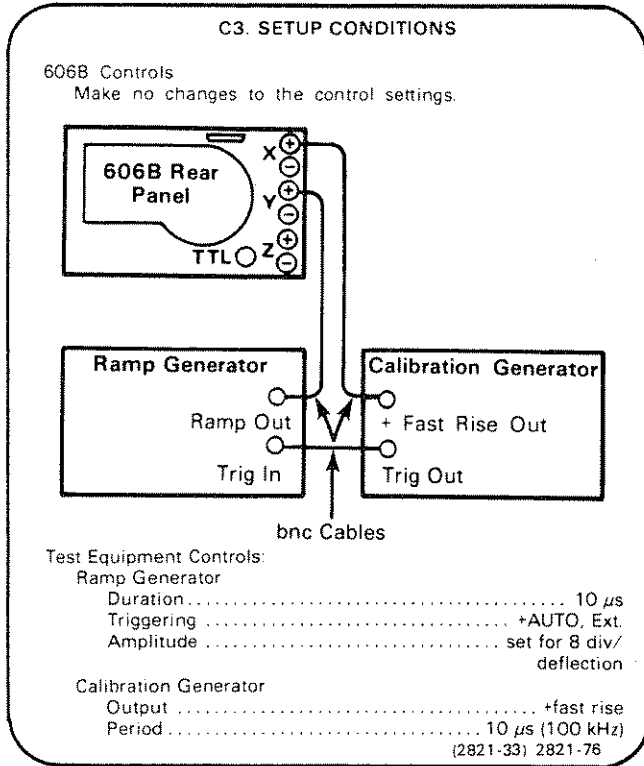

a. Rotate the Var Period control (Calibration Generator) until 1 full cycle is displayed on the crt.

b. **CHECK**—that the time required for the leading edge of the square wave to travel from the zero percent level to the 100 percent level (see Fig. 5-1) is 500 ns (0.4 div) or less, within a trace width (0.008 cm).

C4. CHECK HORIZONTAL BANDWIDTH

NOTE

If the preceding step was not performed, first perform step C1, then proceed.

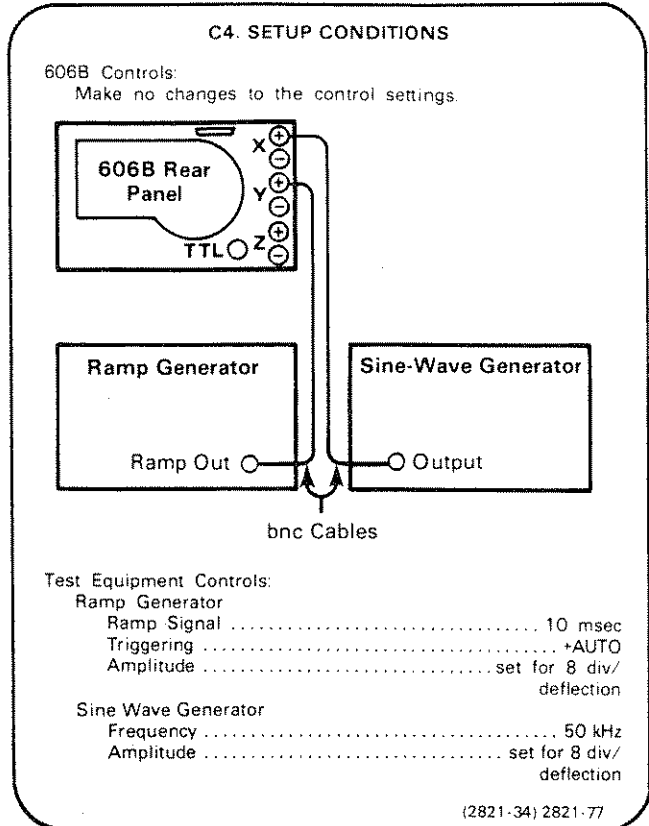

a. Slowly increase the Sine-Wave Generator output frequency until the display amplitude is 5.6 divisions.

b. **CHECK**—That the Sine-Wave Generator frequency is at least 3 MHz.

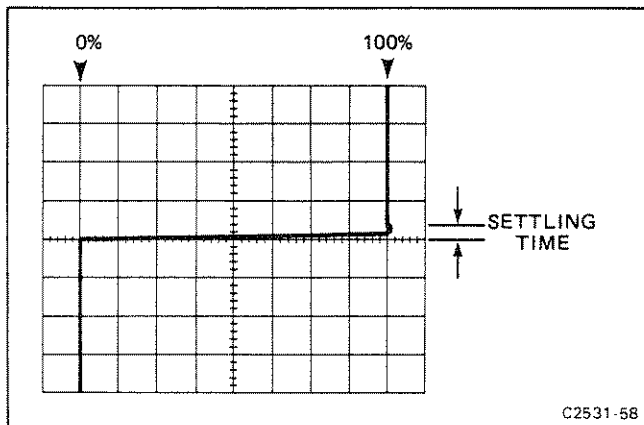
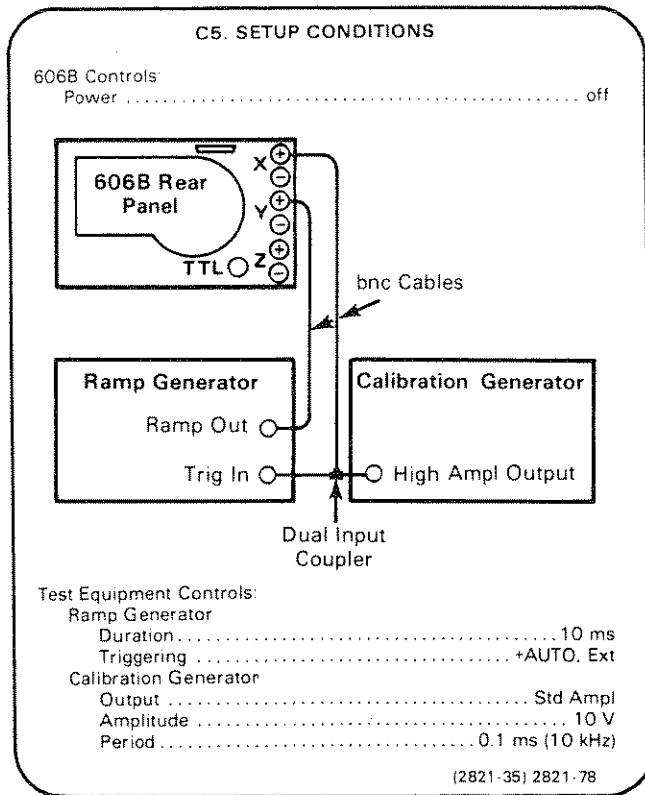

Figure 5-1. Typical crt display for horizontal settling time measurement.

C5. CHECK HORIZONTAL INPUT ATTENUATION

NOTE

If the preceding step was not performed, first perform step C1, then proceed.



- a. Set the + and - atten switches (S100, S105) in the 5X position (back). Turn on the 606B POWER.
- b. **CHECK**—For 8 divisions of horizontal deflection.

C6. CHECK HORIZONTAL (X) COMMON MODE REJECTION (1X, 5X ATTEN)

NOTE

If the preceding step was not performed, first perform step C1, then proceed.

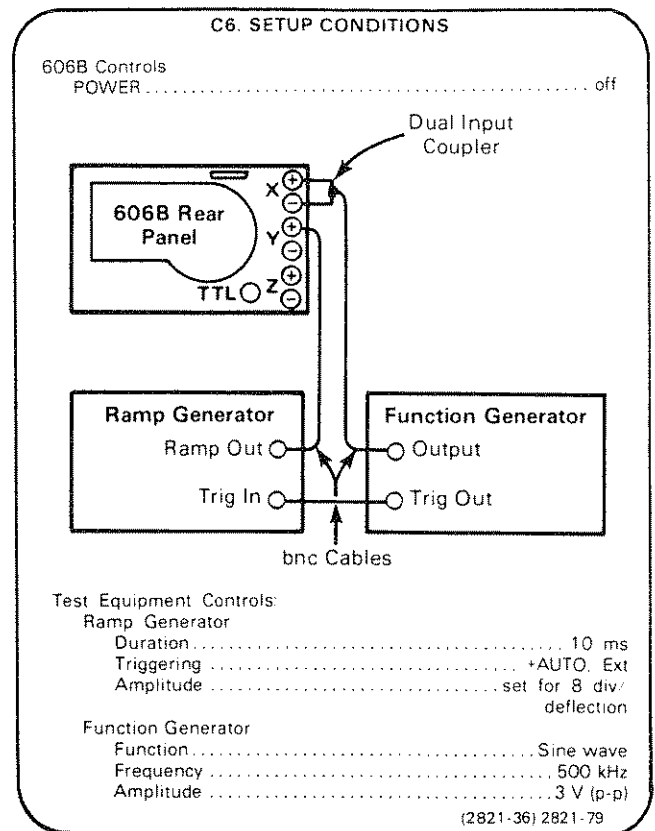

- a. Move the 50 Ω /1 M Ω X INPUT Impedance Selecting Jumpers to the 1 M Ω position.
- b. Turn on the 606B POWER.
- c. Connect the Function Generator output to the test Oscilloscope vertical input. (Do not terminate).
- d. Set the Function Generator controls for a 500 kHz, 3 volt (p-p) sine wave as indicated on the test Oscilloscope.
- e. Disconnect the sine wave signal from the test Oscilloscope and connect it (using the dual-input coupler) to both the +X and -X INPUT connectors on the 606B.
- f. **CHECK**—For 0.24 division, or less, of free running horizontal display on the 606B (position as necessary).
- g. Turn off the 606B POWER. Set S100 (+X Atten) and S105 (-X Atten) to the 5X position (switches back).

**Calibration Part I—606B
Performance Check**

- h. Turn on the 606B POWER.
- i. Repeat part c and d, then increase the Function Generator output to 15 volts (p-p).
- j. Repeat part e.
- k. **CHECK**—For 0.6 division, or less, of free-running horizontal display on the 606B (position as necessary).
- l. Turn off the 606B POWER. Return S100 (+X Atten) and S105 (-X Atten) to the 1X (forward) position.
- m. Change the input impedance to 50 Ω .

D. VERTICAL (Y) AMPLIFIER

Equipment Required: (Numbers correspond to those listed in Table 5-3, Test Equipment.)

- | | |
|---------------------------------------|-------------------------------------|
| 3. Ramp Generator | 10. Function Generator |
| 4. Calibrator Generator | 11. Dual Input Coupler (1 required) |
| 5. Sine Wave Generator | 15. bnc cables (3 required) |
| 9. Test Oscilloscope (with 10X probe) | |

D1. VERTICAL (Y) AMPLIFIER PRELIMINARY SETUP

a. Perform the Performance Check Power-Up Sequence given at the beginning of Part I—Performance Check.

b. Refer to Section 6, Instrument Options, and the Change Information at the rear of this manual for any modifications which may affect this procedure.

c. See **TEST POINT AND ADJUSTMENT LOCATIONS** and **INTERNAL CONTROL AND SELECTOR LOCATIONS** foldout pages in Section 8, Diagrams and Circuit Board Illustrations.

d. Set 606B controls:

INTENSITY Visible display
Vertical and Horizontal Position..... Midrange
FOCUS..... Well-defined display

D2. CHECK POSITIONING AND GAIN

NOTE

Perform step D1, then proceed.

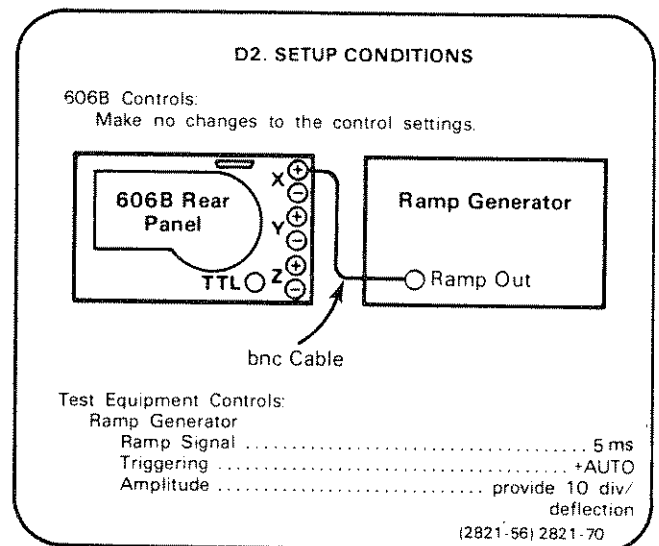

a. **CHECK**—Rotate the vertical Position control and check that the horizontal trace can be positioned vertically anywhere in the graticule area.

b. Reduce the Ramp Generator Amplitude to provide 8 div/deflection on the 606B.

c. Disconnect the Ramp Generator from the +X INPUT and apply it to the test Oscilloscope vertical input. Set Volts/Div switch to 1 V position (with 10X probe).

d. **CHECK**—For a 1-division display on the test Oscilloscope.

D3. CHECK VERTICAL SETTling TIME

NOTE

If the preceding step was not performed, first perform step D1, then proceed.

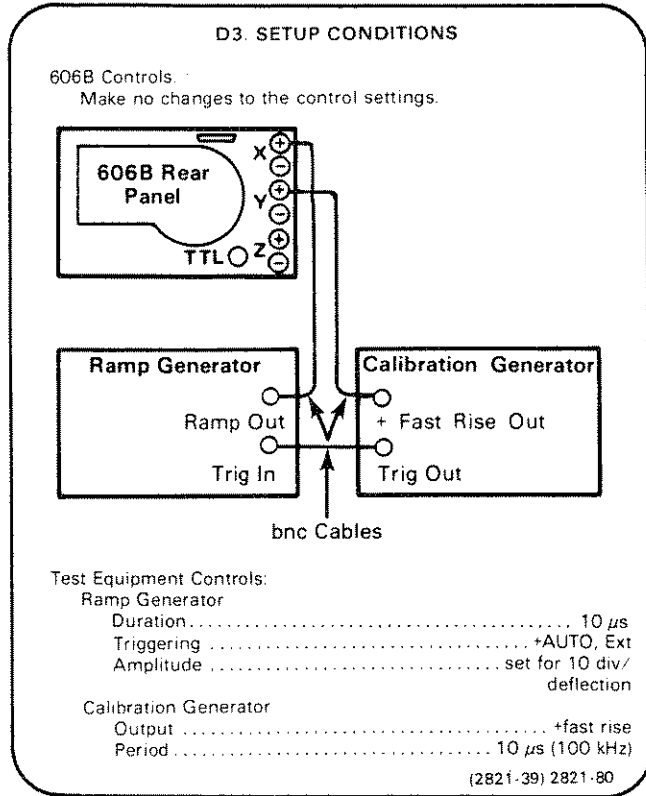

a. Rotate the Var Period control (Calibration Generator) until 1 full cycle is displayed on the crt.

b. **CHECK**—That the time required for the leading edge of the square wave to travel from the zero percent level to the 100 percent level (see Fig. 5-2) is 500 ns (0.4 div) or less, within a trace width (0.008 cm).

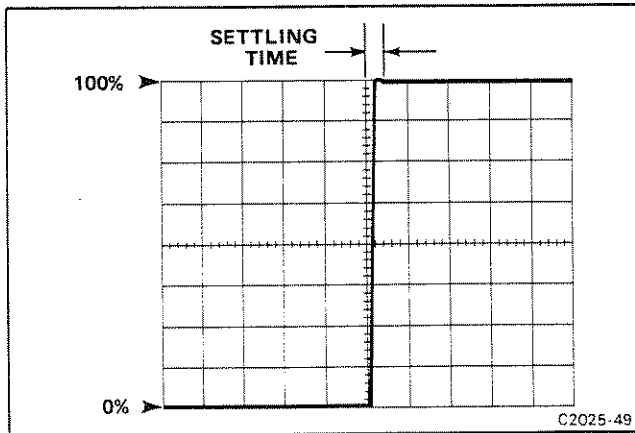
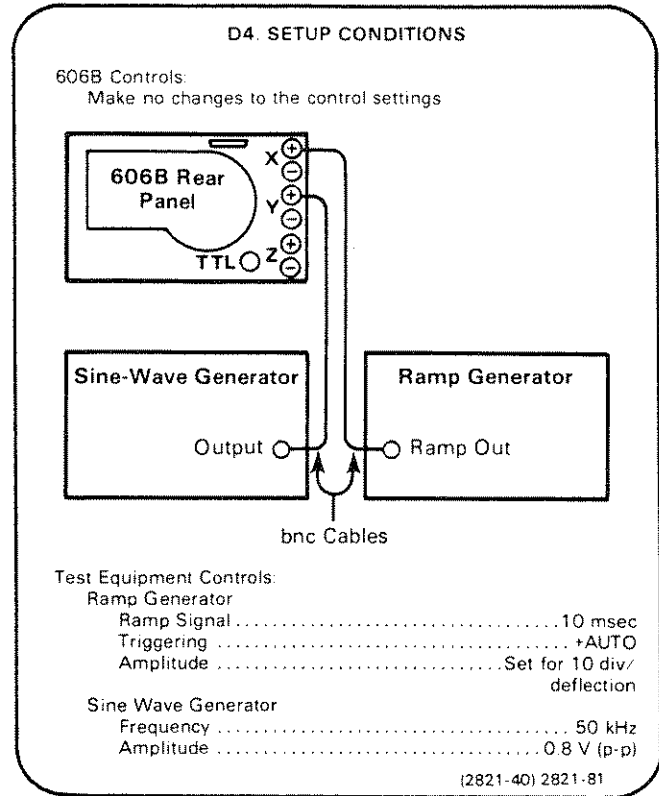

Figure 5-2. Typical crt display for vertical settling time measurement.

D4. CHECK VERTICAL BANDWIDTH

NOTE

If the preceding step was not performed, first perform step D1, then proceed.



a. Set the Sine-Wave Generator amplitude for 6 divisions of deflection.

b. Slowly increase the Sine-Wave Generator output frequency until the display amplitude is 4.2 divisions.

c. **CHECK**—That the Sine-Wave Generator is at least 3 MHz.

D5. CHECK VERTICAL INPUT ATTENUATION

NOTE

If the preceding step was not performed, first perform step D1, then proceed.

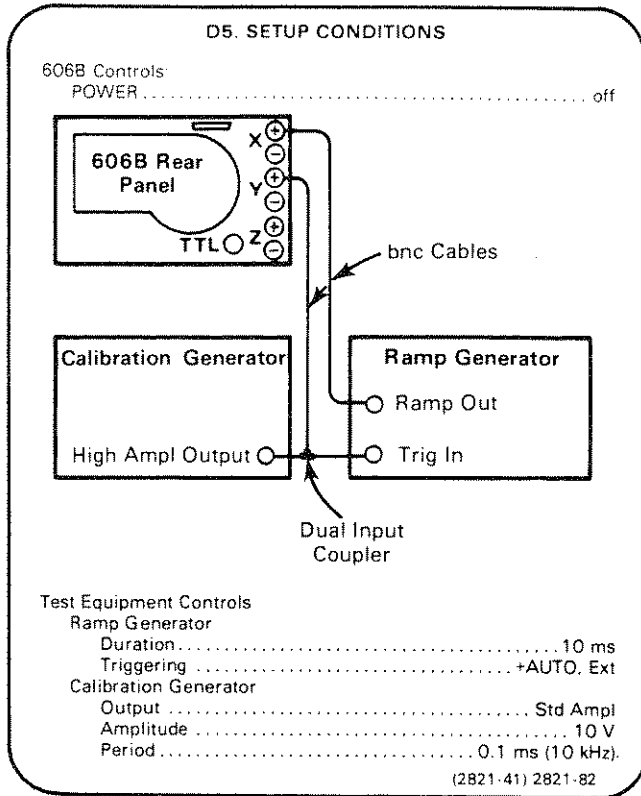

- a. Set the + and - Atten switches (S200, S205) in the 5X position (back). Turn on the 606B POWER.
- b. **CHECK**—For 8 divisions of deflection.

D6. CHECK VERTICAL (Y) COMMON MODE REJECTION (1X, 5X ATTEN)

NOTE

If the preceding step was not performed, first perform step D1, then proceed.

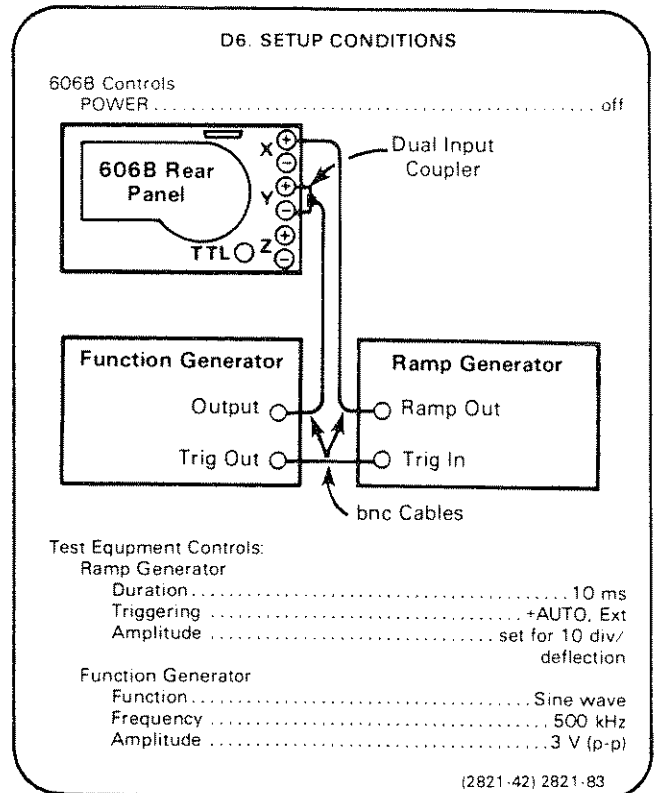

- a. Move the 50 Ω/1 MΩ Y INPUT Impedance Selecting Jumpers to the 1 MΩ position.
- b. Turn on the 606B POWER.
- c. Connect the Function Generator output to the test Oscilloscope vertical input. (Do not terminate.)
- d. Set the Function Generator controls for a 500 kHz, 3 volt (p-p) sine wave as indicated on the test Oscilloscope.
- e. Disconnect the sine-wave signal from the test Oscilloscope and connect it (using the dual-input coupler) to both the +Y and -Y INPUT connectors on the 606B.
- f. **CHECK**—For 0.24 division, or less, of free running vertical display on the 606B (position as necessary).
- g. Turn off the 606B POWER. Set S200 (+Y Atten) and S105 (-Y Atten) to the 5X position (switches back).
- h. Turn on the 606B POWER.

**Calibration Part I—606B
Performance Check**

- i. Repeat part c and d, then increase the Function Generator output to 15 volts (p-p).
- j. Repeat part e.
- k. **CHECK**—For 0.6 division, or less, of free-running vertical display on the 606B (position as necessary).
- l. Turn off the 606B POWER. Return S200 (+Y ATTEN) and S105 (-Y ATTEN) to the 1X (forward) position. Turn on the 606B POWER.

D7. CHECK PHASING

NOTE

If the preceding step was not performed, first perform step D1, then proceed.

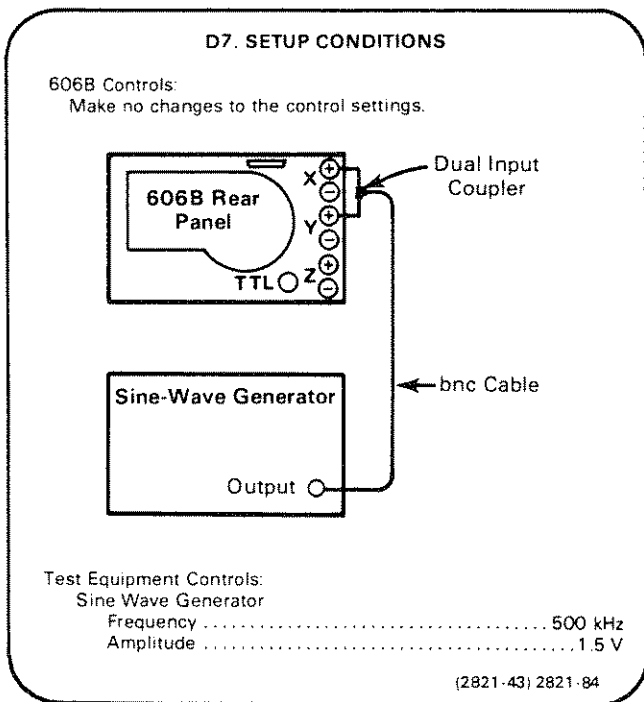

- a. Center the display within the graticule area.
- b. **CHECK**—That the diameter of the displayed ellipse, measured vertically at the center of the graticule, is 0.1 division or less.

E. Z-AXIS AMPLIFIER

Equipment Required: (Numbers correspond to those listed in Table 5-3, Test Equipment.)

- | | |
|---------------------------------------|------------------------------------|
| 3. Ramp Generator | 11. Dual input coupler |
| 4. Calibration Generator | 12. 50 Ω terminator |
| 5. Sine Wave Generator | 14. 10X Attenuator |
| 9. Test Oscilloscope (with 10X probe) | 15. 50 ohm bnc cables (3 required) |
| 10. Function Generator | |

E1. Z-AXIS AMPLIFIER PRELIMINARY SETUP

a. Perform the Performance Check Power-Up Sequence given at the beginning of Part I—Performance Check.

b. Refer to Section 6, Instrument Options, and the Change Information at the rear of this manual for any modifications which may affect this procedure.

c. See **TEST POINT AND ADJUSTMENT LOCATIONS** and **INTERNAL CONTROL AND SELECTOR LOCATIONS** foldout pages in Section 8, Diagrams and Circuit Board Illustrations.

d. Set 606B controls:

INTENSITY Visible display
Vertical and Horizontal Position Midrange
FOCUS Well-defined display

E2. CHECK ABERRATIONS

NOTE

Perform step E1, then proceed.

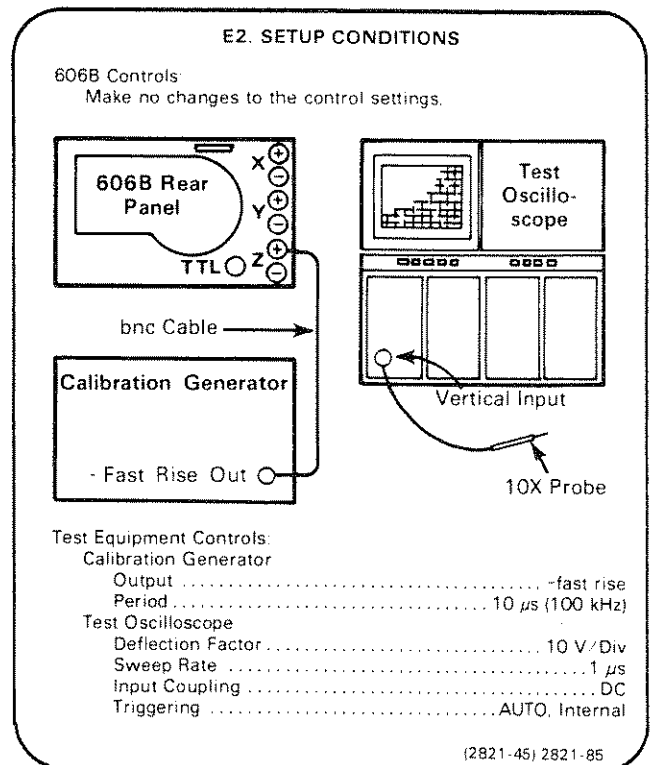

a. Connect a 10X probe from the test Oscilloscope vertical input to TP280.

b. Set the INTENSITY (606B) control and Calibration Generator amplitude for 60 Volts (6 divisions amplitude as indicated on the test Oscilloscope).

**Calibration Part I—606B
Performance Check**

c. **CHECK**—The square wave displayed on the test Oscilloscope for 0.6 division (3 volts) or less aberrations on the top front corner of the displayed pulse.

NOTE

Probes having an input capacitance greater than 4 pF will cause some front corner overshoot at higher output levels. A 3-5% overshoot at 70 V output is normal with probes having 10 pF capacitance.

E3. CHECK Z-AXIS AMPLIFIER BANDWIDTH

NOTE

If the preceding step was not performed, first perform step E1, then proceed.

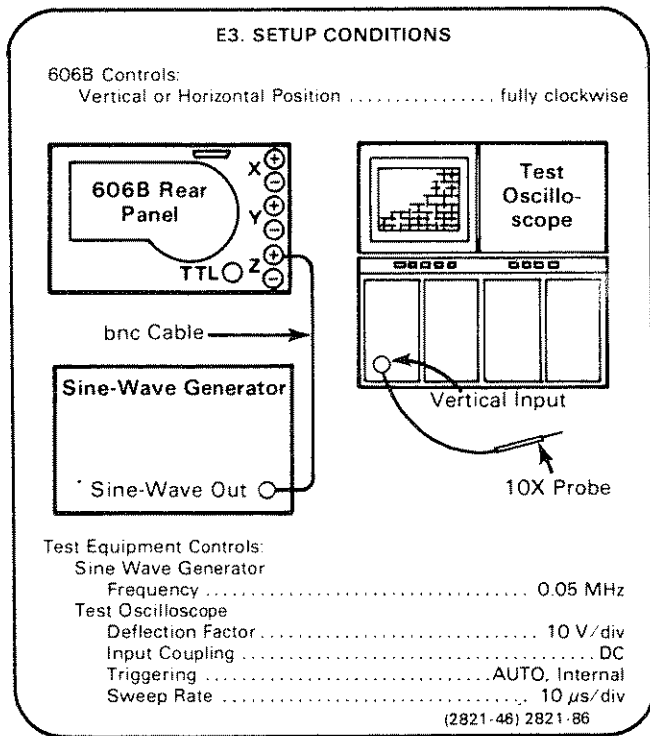

a. Connect a 10X probe from the test Oscilloscope vertical input to TP280.

b. Set the 606B INTENSITY control and the Sine Wave Generator Amplitude for a 7-division (70 V) display on the test Oscilloscope. (Make sure no clipping occurs on the test Oscilloscope display.)

c. Slowly increase the Sine-Wave Generator output frequency until the display amplitude is 4.9 divisions on the test Oscilloscope.

d. **CHECK**—That the Sine-Wave Generator output frequency is at least 5 megahertz.

E4. CHECK Z-AXIS COMMON MODE REJECTION

NOTE

If the preceding step was not performed, first perform step E1, then proceed.

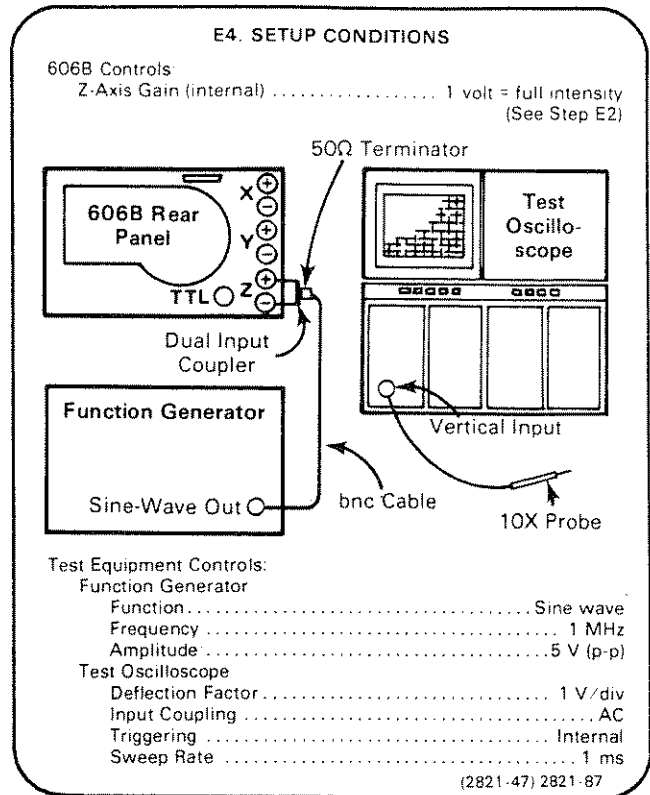

NOTE

Verify that the Z-Axis Gain is set for 1 volt full intensity before performing this step. Input Impedance Selecting jumpers (P102, P106) are in the 1 M Ω position as shipped from the factory.

a. Connect the 10X probe from TP280 to the vertical input of the test Oscilloscope.

b. **CHECK**—The test Oscilloscope for 3.5 divisions (3.5 V) or less.

E5. CHECK Z-AXIS BLANKING

NOTE

If the preceding step was not performed, first perform step E1, then proceed.

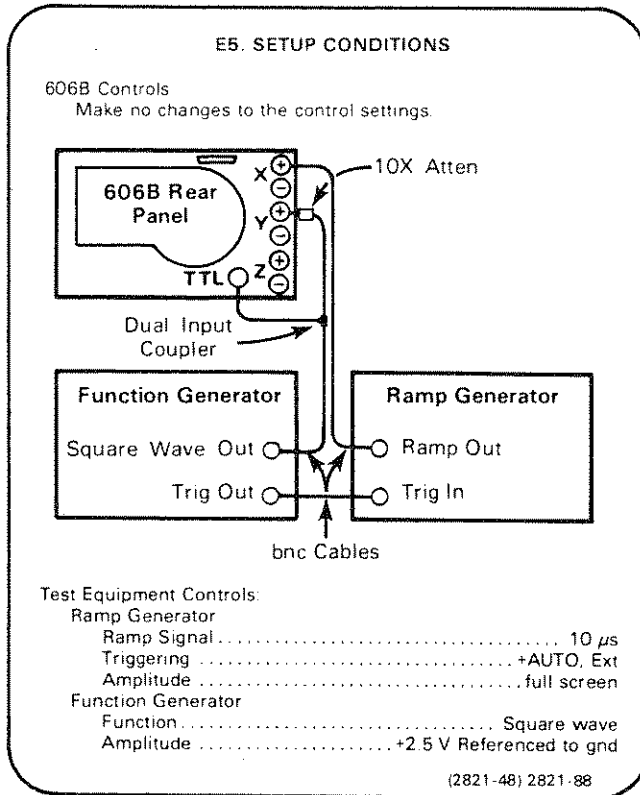

- a. Disconnect the signal to the Y INPUT.
- b. **EXAMINE**—That the full square wave is visible. Connect the signal to the Y INPUT.
- c. Turn off the 606B. Move P176 and P179 to the LO (+) position.
- d. **CHECK**—That only the positive portion of the square wave is displayed.
- e. Turn off the 606B POWER. Move the jumpers (P176, P179) to the (-) position.
- f. **CHECK**—That only the negative portion of the square wave is displayed.

NOTE

The Blanking Level Selecting jumpers should remain in the LO (+) position for normal operation.

F. DYNAMIC FOCUS

Equipment Required: (Numbers correspond to those listed in Table 5-3, Test Equipment.)

- | | |
|--------------------------------|-----------------------------|
| 1. Digital Voltmeter (DVM) | 15. bnc cables (4 required) |
| 3. Ramp Generator (2 required) | 22. 24X Magnifier |
| 8. Digital Counter | |

F1. DYNAMIC FOCUS PRELIMINARY SETUP

a. Perform the Performance Check Power-Up Sequence given at the beginning of Part I—Performance Check.

b. Refer to Section 6, Instrument Options, and the Change Information at the rear of this manual for any modifications which may affect this procedure.

c. See **TEST POINT AND ADJUSTMENT LOCATIONS** and **INTERNAL CONTROL AND SELECTOR LOCATIONS** foldout pages in Section 8, Diagrams and Circuit Board Illustrations.

d. Set 606B controls:

INTENSITY Visible display

Vertical and Horizontal
Position Position the dot
to center screen
(within 0.2 division)

F2. CHECK SPOT DIAMETER

NOTE

Perform step F1, then proceed.

F2. SETUP CONDITIONS

606B Controls:
INTENSITY fully counterclockwise

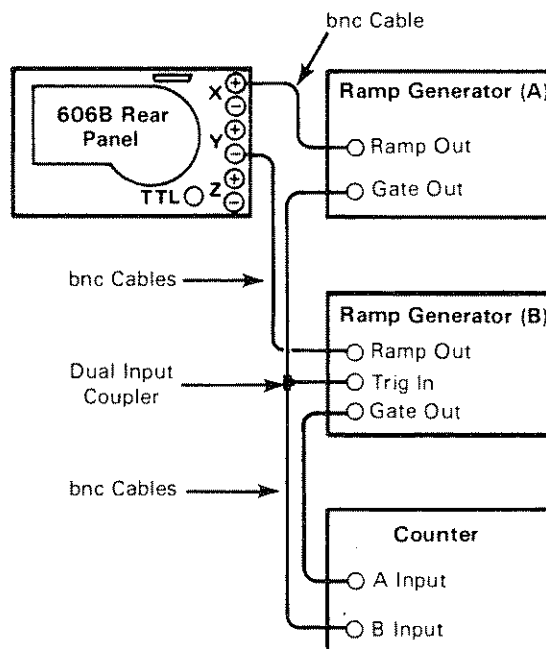

Test Equipment Controls:

Ramp Generator (A)
Ramp Signal 100 μ s
Triggering +AUTO
Amplitude provide approx
1 inch deflection

Ramp Generator (B)
Ramp Signal 10 ms
Triggering norm. Ext.
Amplitude provide approx
1 inch deflection

Counter
Atten X1
Coupling AC
Function Ratio A/B averaged
over 10^2 cycles of B
Slope Slope
DVM (Digital Voltmeter)
Range Function 20 V dc

(2821-58) 2821-75

a. Connect the DVM between TP280 (Z-Axis output) and ground. Rotate the INTENSITY control till a reading of +20 V is measured at TP280.

NOTE

The intensity is now set to approximately $3.5 \mu\text{W}/\text{cm}^2$. This setting is sufficiently accurate under normal circumstances for verification of the spot size, however, a photometer may be used if available.

Place the Photometer probe against the face of the crt while displaying a 700 line, 7×9 cm raster. Rotate the INTENSITY until a reading of $3.5 \mu\text{W}/\text{cm}^2$ is read on the photometer.

b. Disconnect the DVM. Do not move the INTENSITY control.

c. Using the Level control of Ramp Generator (A) provide a synchronized raster.

d. While viewing the raster with a 24X magnifier, rotate the duration multiplier (Ramp Generator A) clockwise until the lines just merge to a uniform field.

e. Record the Counter reading.

f. Turn off the 606B POWER.

g. Interchange the 606B X and Y inputs (to check horizontal spot diameter).

h. Turn on the 606B POWER.

i. Set the Amplitude of Ramp Generator B to provide exactly one inch of deflection.

j. Repeat part d.

k. **CHECK**—The average of the present Counter reading and the reading recorded in part e. The average of the two readings must be 0.0031 inch or less.

l. Turn off the 606B POWER.

This completes the Part I—Performance Check procedure.

PART II—ADJUSTMENT AND PERFORMANCE CHECK

The following procedure (Part II—Adjustment and Performance Check) provides the information necessary to: (1) verify that the instrument meets the electrical specifications, (2) verify that the controls function properly, and (3) perform all internal adjustments.

Part I—Performance Check verifies that the instrument meets the electrical specifications without making internal adjustments. All tolerances given are as specified in the Specification tables (section 1) in this manual.

A separate Checkout Procedure is provided in section 2 for instrument familiarization and also to verify that the controls function properly.

See Table 5-1, Calibration Procedure Electives, at the beginning of this section, for information on performing a Partial Part II—Adjustment and Performance Check Procedure.

INDEX TO PART II— ADJUSTMENT AND PERFORMANCE CHECK

	PAGE
A. POWER SUPPLIES	5-30
1. Power Supplies Preliminary Setup	5-30
2. Adjust +15 V Supply	5-30
3. Examine -15 V Supply	5-30
4. Adjust +250 V Supply	5-31
5. Adjust Freq (R124)	5-31
6. Examine +95 V Supply	5-32
7. Adjust -5400 V Supply	5-32
B. CRT	5-33
1. Crt Preliminary Setup	5-33
2. Adjust Crt Grid Bias (R245)	5-33
3. Adjust Trace Align (R290 Front Panel) And Check Orthogonality	5-34
4. Check/Adjust Geometry (R185)	5-34
C. HORIZONTAL (X) AMPLIFIER	5-35
1. Horizontal (X) Amplifier Preliminary Setup	5-35
2. Adjust X Output Dc Level	5-35
3. Adjust X Amplifier Gain (R104, R109, R129) And Check Positioning	5-36
4. Adjust X Amplifier Compensation (C106, C108, C179, R103) And Examine Scan Limiter	5-37
5. Check Horizontal Settling Time	5-38
6. Check Horizontal Bandwidth	5-38
7. Adjust Horizontal (X) Attenuation Compensation (C103, C107) And Check Horizontal Input Attenuation	5-39
8. Check Horizontal (X) Common Mode Rejection (1X, 5X Atten)	5-40
D. VERTICAL (Y) AMPLIFIER	5-41
1. Vertical (Y) Amplifier Preliminary Setup	5-41
2. Adjust Y Amplifier Gain (R204, R209, R229) And Check Positioning	5-41
3. Adjust Y Amplifier Compensation (C206, C208, C279) And Examine Scan Limiter	5-42
4. Check Vertical Settling Time	5-43
5. Check Vertical Bandwidth	5-44
6. Adjust Vertical (Y) Attenuator Compensation (C203, C207) And Check Vertical Input Attenuation	5-44
7. Check Vertical (Y) Common Mode Rejection (1X, 5X Atten)	5-45
8. Check Phasing	5-46
E. Z-AXIS AMPLIFIER	5-47
1. Z-Axis Amplifier Preliminary Setup	5-47
2. Adjust Z-Axis Gain (R124)	5-47
3. Adjust Z-Axis Compensation (R239 And C285) And Check Aberrations	5-48
4. Check Z-Axis Amplifier Bandwidth	5-49
5. Check Z-Axis Common Mode Rejection	5-49
6. Check Z-Axis Blanking	5-50
F. DYNAMIC FOCUS	5-51
1. Dynamic Focus Preliminary Setup	5-51
2. Adjust Bias (R306)	5-51
3. Adjust Focus And Stigmators (With Dot Generator)	5-52
4. Adjust Focus And Stigmators (Without Dot Generator)	5-53
5. Check Spot Diameter	5-55

ADJUSTMENT AND PERFORMANCE CHECK POWER-UP SEQUENCE

NOTE

The performance of this instrument can be checked at any ambient temperature from 0° to +50° C unless otherwise stated. Adjustments must be performed at an ambient temperature from +15° to +25° C for specified accuracies.

1. Remove any cabinet panels to gain access to the internal controls, selectors and test points.
2. Check that the internal Line Voltage Selector plug has been set to the appropriate line voltage and range. (See Fig. 1-1 of Section 1, General Information).
3. Check the rear panel to determine which options have been installed in your Monitor.
4. Check that grounding caps are on the -INPUTs.

5. Check that the Input Impedance Selecting jumpers for the X and Y Amplifiers are in the 50 Ω position.
6. Check that the crt has an implosion shield with 8 \times 10 division graticule.
7. Connect the Monitor and appropriate test equipment to the power source.
8. Set 606B INTENSITY to midrange.

CAUTION

Do not allow a high-intensity dot to remain stationary on the crt. The crt phosphor could be permanently damaged.

9. Switch on the Monitor and appropriate test equipment and allow at least 20 minutes warmup before proceeding.

A. POWER SUPPLIES

Equipment Required: (Numbers correspond to those listed in Table 5-3, Test Equipment.)

- | | |
|---|------------------------------|
| 1. Digital Voltmeter (DVM) (low-voltage supplies) | 21. Variable AC Power Supply |
| 2. DC Voltmeter (high-voltage supply) | |

A1. POWER SUPPLIES PRELIMINARY SETUP

a. Perform the Adjustment and Performance Check Power Up Sequence.

b. Refer to Section 6, Instrument Options, and the Change Information at the rear of this manual for any modifications which may affect this procedure.

c. See **TEST POINT AND ADJUSTMENT LOCATIONS** and **INTERNAL CONTROL AND SELECTOR LOCATIONS** foldout pages in Section 8, Diagrams and Circuit Board Illustrations.

d. Set 606B controls:

INTENSITY fully counter-clockwise
Vertical and Horizontal Position..... off-screen

A2. ADJUST +15 V SUPPLY

NOTE

First perform step A1, then proceed.

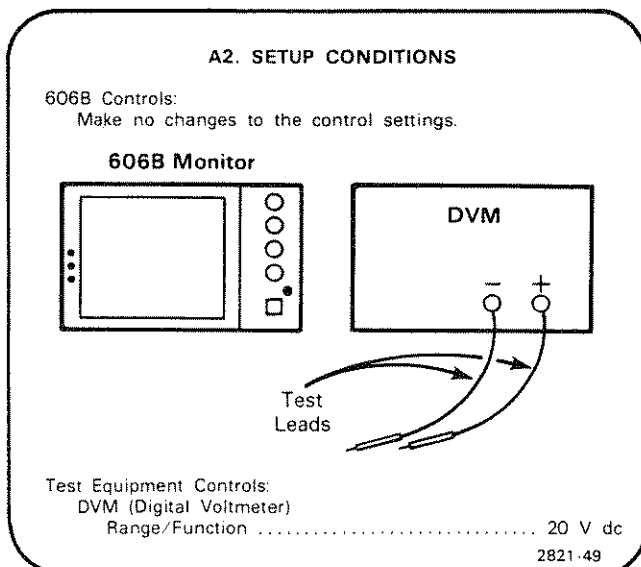

a. Connect the DVM test leads between the +15 V test point (TP352) and ground (TP353).

b. **EXAMINE**—For a voltage reading within the range given in Table 5-4.

c. **ADJUST**—R337 for a voltmeter reading of exactly +15.0 V dc.

A3. EXAMINE -15 V SUPPLY

NOTE

If the preceding step was not performed, first perform step A1, then proceed.

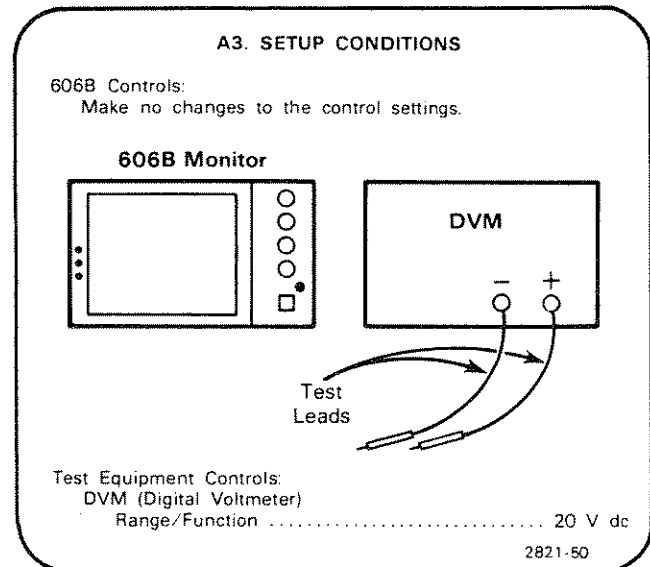

a. Connect the DVM between the -15 V test point (TP354) and ground (TP353).

b. **EXAMINE**—For a voltage reading within the range given in Table 5-4.

TABLE 5-4
Low-Voltage Supply Limits

Supply (dc)	Test Point	Limits (Volts dc)	Ripple (p-p)
+15 V	TP352	+14.95 to +15.05	2 mV or less
-15 V	TP354	-15.2 to -14.8	2 mV or less
+95 V	TP351	+94.0 to +98.0	100 mV or less
+250 V	TP350	+249 to +251	150 mV or less

A4. ADJUST +250 V SUPPLY

NOTE

If the preceding step was not performed, first perform step A1, then proceed.

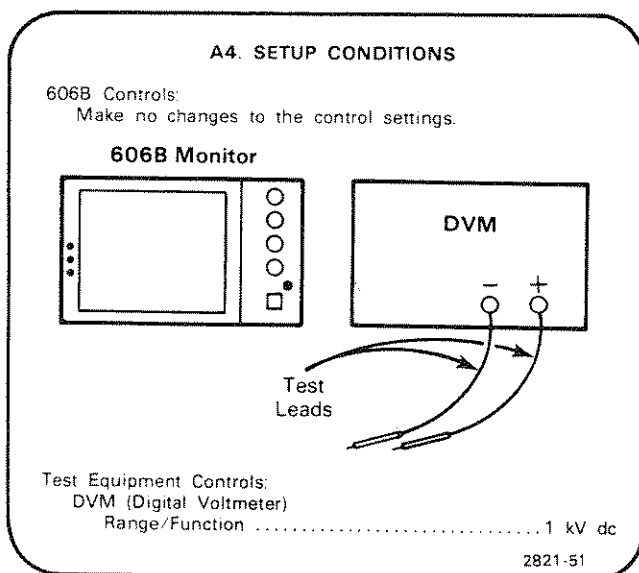

a. Connect the DVM between the +250 V test point (TP350) and ground (TP353).

b. **EXAMINE**—For a voltage reading within the range given in Table 5-4.

c. Remove the high voltage shield.

d. **ADJUST**—R112 (250 V Adj, located on the Converter board) for a voltmeter reading of exactly +250 V.

A5. ADJUST FREQ (R124)

NOTE

If the preceding step was not performed, first perform step A1, then proceed.

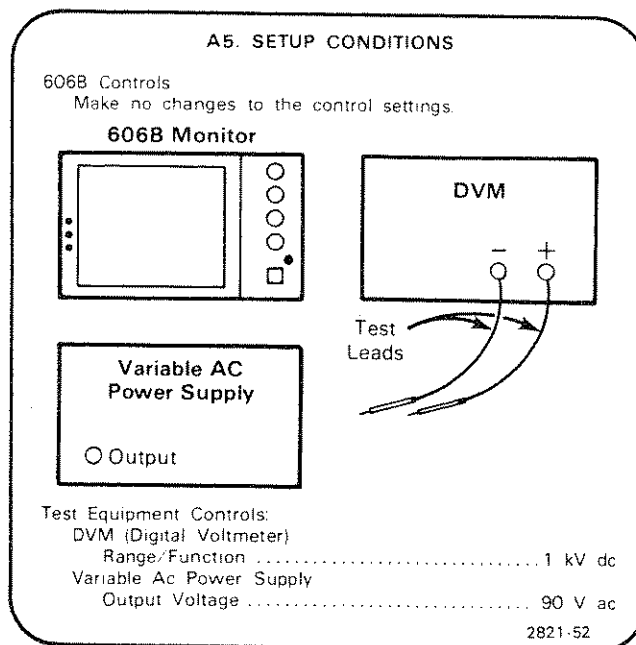

a. Disconnect the 606B from the power source and Connect the 90 volts from the Variable AC Power Supply to the 606B rear-panel power input.

b. Connect the DVM between the +250 V Test point (TP350) and ground (TP353).

c. **ADJUST**—R124 (FREQ) for maximum voltage at TP350.

d. Set the line voltage to 107 V ac (Variable AC Power Supply).

e. Position dot off screen and set INTENSITY full on.

f. **ADJUST**—R124 (FREQ) CCW until the +250 V Supply first moves, then approximately 10° CW.

g. Reduce the INTENSITY control to midrange.

h. Reset the line voltage to 120 V ac.

A6. EXAMINE +95 V SUPPLY

NOTE

If the preceding step was not performed, first perform step A1, then proceed.

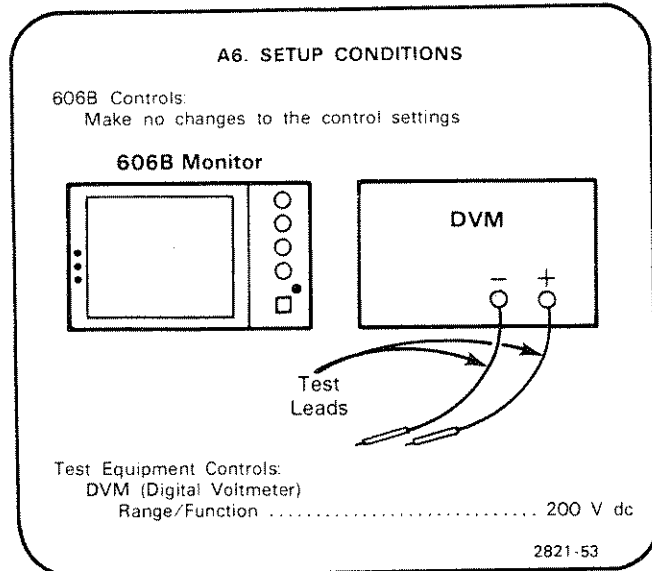

a. Connect the DVM between the +95 V test point (TP351) and ground (TP353).

b. **EXAMINE**—For a voltmeter reading within the range given in Table 5-5.

A7. ADJUST -5400 V SUPPLY

NOTE

If the preceding step was not performed, first perform step A1, then proceed.

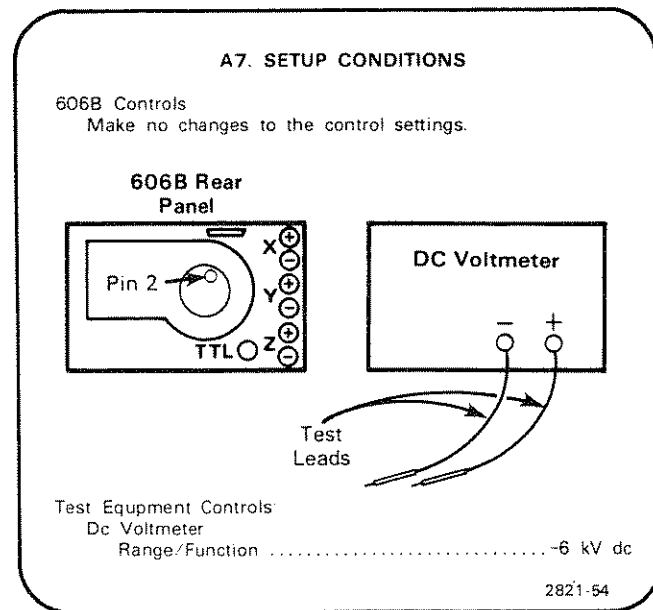

a. Turn off the 606B POWER.

b. Remove the rear cover (see Fig. 4-4 in Maintenance Section) and locate the test port in the crt socket cover assembly.

c. Connect the DC Voltmeter between V50 (crt) pin 2 (accessible through test port) and ground.

d. Turn on the 606B POWER.

e. **EXAMINE**—For a voltage reading between -5350 and -5450.

f. **ADJUST**—R295 (HV Adj) for a voltage reading of approximately -5400 volts.

g. **EXAMINE**—For no movement of the -5400 V Supply when the INTENSITY is varied.

CAUTION

A high intensity spot or slow-scanning display will damage the crt phosphor. Be sure the display is positioned off screen while examining for no movement of the -5400 V Supply.

h. Turn off the 606B POWER.

i. Remove the test leads from the Monitor and replace the rear cover and the high voltage shield.

B. CRT

Equipment Required: (Numbers correspond to those listed in Table 5-3, Test Equipment.)

- | | |
|--------------------------------|----------------------|
| 1. DVM (Digital Voltmeter) | 15. 50-ohm bnc cable |
| 3. Ramp Generator (2 required) | |

B1. CRT PRELIMINARY SETUP

a. Perform the Adjustment and Performance Check Power-Up Sequence given at the beginning of Part II—Adjustment and Performance Check.

b. Refer to Section 6, Instrument Options, and the Change Information at the rear of this manual for any modifications which may affect this procedure.

c. See **TEST POINT AND ADJUSTMENT LOCATIONS** and **INTERNAL CONTROL AND SELECTOR LOCATIONS** foldout pages in Section 8, Diagrams and Circuit Board Illustrations.

d. Set 606B controls:

INTENSITY Visible display
Vertical and Horizontal Position..... Midrange
FOCUS..... Well-defined display

a. Position the sharply focused dot display near graticule center.

b. Rotate the INTENSITY control counter-clockwise till the dot just disappears.

c. Connect the DVM between TP280 (Z-Axis out) and ground (TP353).

d. **EXAMINE**—For a DVM reading of approximately 0 volt.

e. Set the INTENSITY control for a DVM reading of 0 volt.

NOTE

If in part e the dot disappears, rotate the Grid Bias (R245) till the dot becomes visible then proceed with part f.

f. **ADJUST**—R245 (Grid Bias) until the dot just disappears.

g. Disconnect the DVM from the Monitor.

h. Set the INTENSITY control for a visible display.

B2. ADJUST CRT GRID BIAS (R245)

NOTE

First perform Step B1, then proceed.

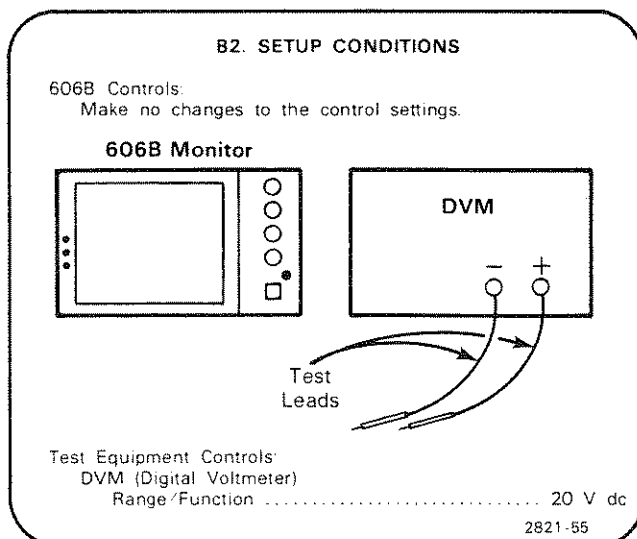

B3. ADJUST TRACE ALIGN (R290 FRONT PANEL) AND CHECK ORTHOGONALITY

NOTE

If the preceding step was not performed, first perform step B1, then proceed.

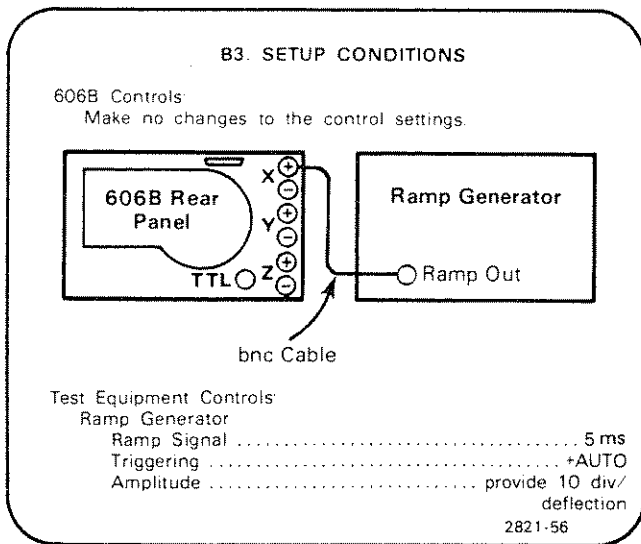

- a. Position the trace to the center horizontal graticule line.
- b. **EXAMINE**—The trace for alignment with the horizontal graticule line.
- c. **ADJUST**—R290 (front panel TRACE ALIGN) to align the trace with the center horizontal graticule line.
- d. Disconnect the Ramp Generator from the +X INPUT and connect it to the +Y INPUT. Reduce the Ramp-Generator Amplitude to provide 8-divisions of vertical deflection.
- e. Position the trace to the center vertical graticule line.
- f. **CHECK**—That the vertical trace is aligned with the center vertical graticule line at the top and bottom of the graticule within 0.1 division.

B4. CHECK/ADJUST GEOMETRY (R185)

NOTE

If the preceding step was not performed, first perform Step B1, then proceed.

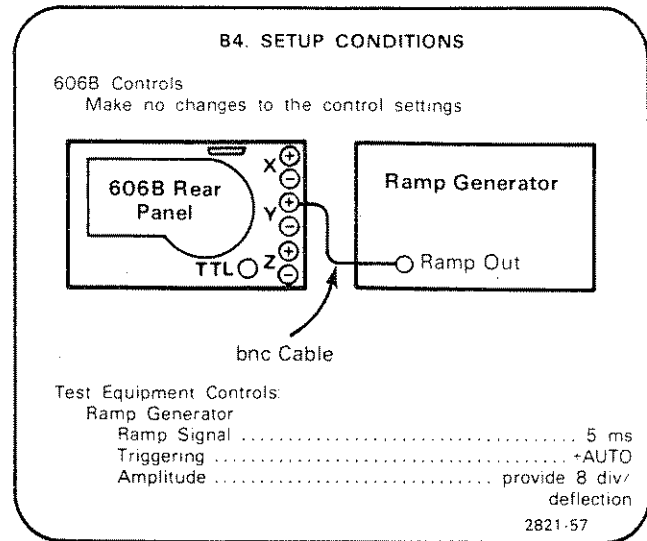

- a. Position the trace to the left edge of the graticule, and then to the right edge.
- b. **CHECK**—the vertical trace for 0.1 division or less of bowing at the left and right edges of the graticule.
- c. **ADJUST**—R185 (Geometry) for minimum trace bowing at the left and right edges of the graticule.
- d. Disconnect the Ramp Generator from the +Y INPUT and connect it to the +X INPUT. Horizontally center the display on the graticule. Increase the Ramp Amplitude (Ramp Generator) to provide full screen-width (10 division) deflection.
- e. Position the horizontal trace to the top edge of the graticule, and then to the bottom edge.
- f. **CHECK**—The horizontal trace for 0.1 division or less of bowing at the top and bottom edges of the graticule.
- g. **INTERACTION**—If necessary, readjust R185 (Geometry) for minimum trace bowing at the top and bottom edges of the graticule. Then, reconnect the Ramp Generator to the +Y INPUT and repeat step B4 until optimum geometry is achieved.

C. HORIZONTAL (X) AMPLIFIER

Equipment Required: (Numbers correspond to those listed in Table 5-3, Test Equipment).

- | | |
|----------------------------|-----------------------------|
| 1. Digital Voltmeter (DVM) | 11. Dual-Input Coupler |
| 3. Ramp Generator | 15. bnc cables (3 required) |
| 4. Calibration Generator | 21. 9X Magnifier |
| 5. Sine-Wave Generator | |
| 10. Function Generator | |

C1. HORIZONTAL (X) AMPLIFIER PRELIMINARY SETUP

a. Perform the Adjustment and Performance Check Power-Up Sequence given at the beginning of Part II—Adjustment and Performance Check.

b. Refer to Section 6, Instrument Options, and the Change Information at the rear of this manual for any modifications which may affect this procedure.

c. See **TEST POINT AND ADJUSTMENT LOCATIONS** and **INTERNAL CONTROL AND SELECTOR LOCATIONS** foldout pages in Section 8, Diagrams and Circuit Board Illustrations.

d. Set 606B Controls:

INTENSITY Visible display
Vertical and Horizontal Position..... Midrange
FOCUS..... Well-defined display

C2. ADJUST X OUTPUT DC LEVEL

NOTE

Perform step C1, then proceed.

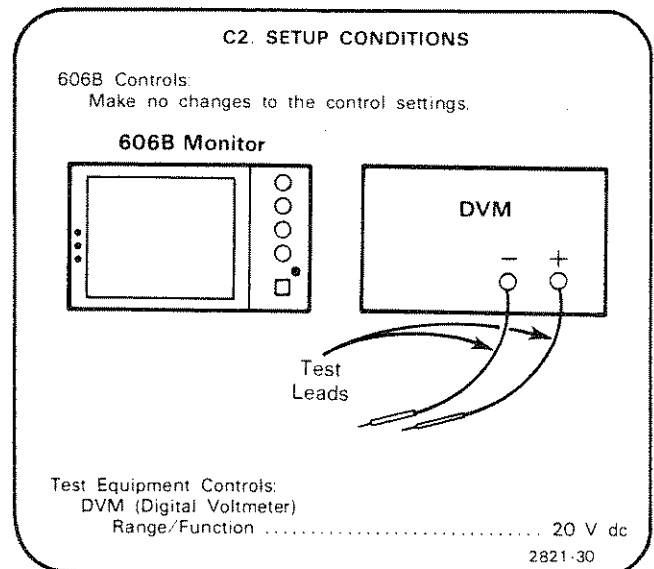

a. Position the display to graticule center.

b. With no signal applied to the X INPUT, connect the Precision Dc Voltmeter probes between the X Output Amplifier outputs (TP173, TP178).

c. Set the voltage between TP173 and TP178 to 0 Volt within 1 Volt, using the horizontal position control on the 606B.

d. Remove the DVM LO (-) INPUT lead from the test points (TP173 or TP178) and connect it to chassis ground.

Calibration Part II—606B
Adjustment and Performance Check

e. **EXAMINE**—DVM for X plate dc level of +125 V within 1 volt.

f. **ADJUST**—The X Plate DC Level (R119) for +125 V within 1.0 V.

WARNING

Up to 250 V dc at potentially lethal currents are present at the power transistor tabs and at other points on the X-Y Output Amplifier board. Use caution when servicing.

C3. ADJUST X AMPLIFIER GAIN (R104, R109, R129) AND CHECK POSITIONING

NOTE

If the preceding step was not performed, first perform step C1, then proceed.

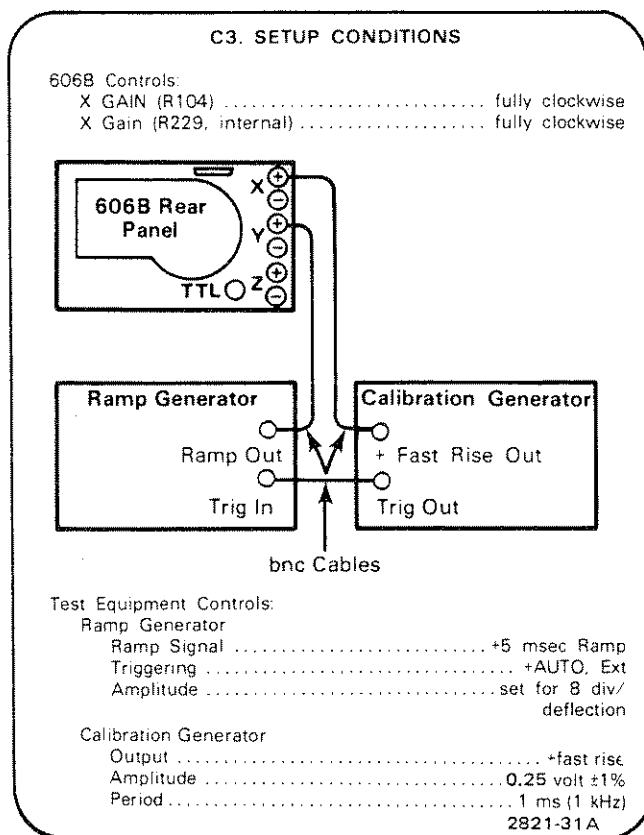

NOTE

This procedure adjusts all gain set controls (R104, R109, R129) for the Horizontal (X) Amplifier. Normally, the Output Amplifier Gain (R109) will not be adjusted unless the X-Y Output Amplifier board has been serviced or the crt has been replaced.

The Calibration Generator output must be set within 1% nominally for this adjustment. Check that input impedance selecting jumpers (P101, P105) are in the 50 Ω position.

a. Assure that attenuator switches (S100, S105) are in the 1X position and grounding caps are on all unused INPUTS.

b. Position the display near horizontal screen center.

c. **EXAMINE**—For a crt display of exactly 4.5 cm amplitude.

d. **ADJUST**—R109 (Output Amplifier Gain) located on the X-Y Output for a crt display of exactly 4.5 cm amplitude.

NOTE

This adjustment standardizes the output amplifier gain, and must not be used for adjusting deflection sensitivity. Altering this adjustment will change HF Compensation and misadjustment may cause output amplifier saturation, resulting in poor off-screen recovery and degradation of settling time performance.

e. **ADJUST**—X GAIN (R104, front panel) for a crt display of exactly 4 cm of deflection.

f. Disconnect the Calibration Generator from the Monitor.

g. **CHECK**—Rotate the horizontal Position control and check that the vertical trace can be positioned horizontally anywhere in the graticule area.

NOTE

The Horizontal system is now adjusted to maximum sensitivity (0.5V/8cm). This internal X Gain (R129, X-Y Pre-Amplifier board) may be readjusted for any deflection factor within specified limits (0.5V/8cm to ≥2.5V/8cm) by applying the desired input amplitude and adjusting for appropriate horizontal deflection.

This instrument is factory adjusted for a deflection factor at 1V/8cm within 2%.

C4. ADJUST X AMPLIFIER COMPENSATION (C106, C108, C179, R103) AND EXAMINE SCAN LIMITER

NOTE

If the preceding step was not performed, first perform step C1, then proceed.

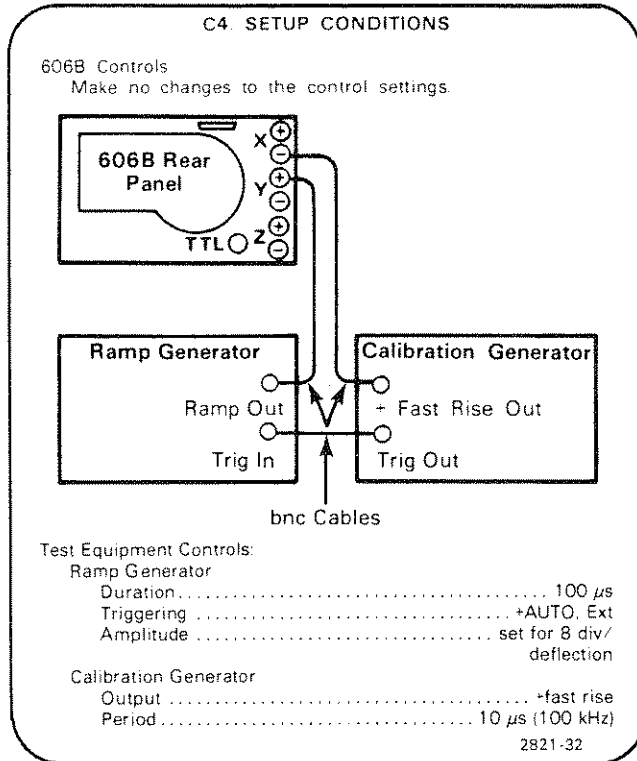

NOTE

The use of a hand magnifier of at least 5X is necessary for observing the square-wave front corner and flatness. The alignment tool must be a low capacitance; insulated type. Remove the tool from the adjustment screw before determining that the adjustment is optimum.

The capacitance shield must be in place for the following adjustments.

- a. Set the square-wave amplitude to provide 7.5 cm of horizontal deflection, then center the display using the horizontal Position control.
- b. Using the front panel FOCUS control, adjust the trace for optimum width while observing with the hand magnifier.

NOTE

R103 affects the "sharpness" of the leading corner. Adjust so that the corner and the area just after the corner is flat.

- c. **ADJUST**—C106 (HF Comp 1) and R103 (HF Comp 3) for optimum bottom leading corner.
- d. Remove the square wave from the -X INPUT and apply it to the +X INPUT. Install the grounding cap on the unused input. Center the display.
- e. **EXAMINE**—The front corner, and move C179 (HF Comp 2) slightly to verify that the corner is optimum.

NOTE

If C179 or the board was replaced, preset C179 to approximately 1/2 its adjustable length.

- f. **ADJUST**—C179 (HF Comp 2) for optimum front corner. (Use the hand magnifier for close observation).
- g. **INTERACTION**—Repeat steps c and f, adjusting C179 (HF Comp 2) for the top (+) corner and C106 (HF Comp 1) for the bottom (-) corner until both positive and negative going waveforms are optimum.
- h. Increase the ramp duration to 3 ms and set the Calibration Generator period to 0.1 ms (10 kHz) to obtain about 4 cycles/cm.
- i. **ADJUST**—C108 (LF Comp) for optimum front corner.
- j. Move C179 slightly to verify that the front corner is optimum.

NOTE

The last fine adjustment should be made with C179.

- k. Position the display slowly, left and right of graticule center until 1 cm remains on screen.
- l. **EXAMINE**—That no visible shift in front corner response occurs.

C5. CHECK HORIZONTAL SETTLING TIME

NOTE

If the preceding step was not performed, first perform step C1, then proceed.

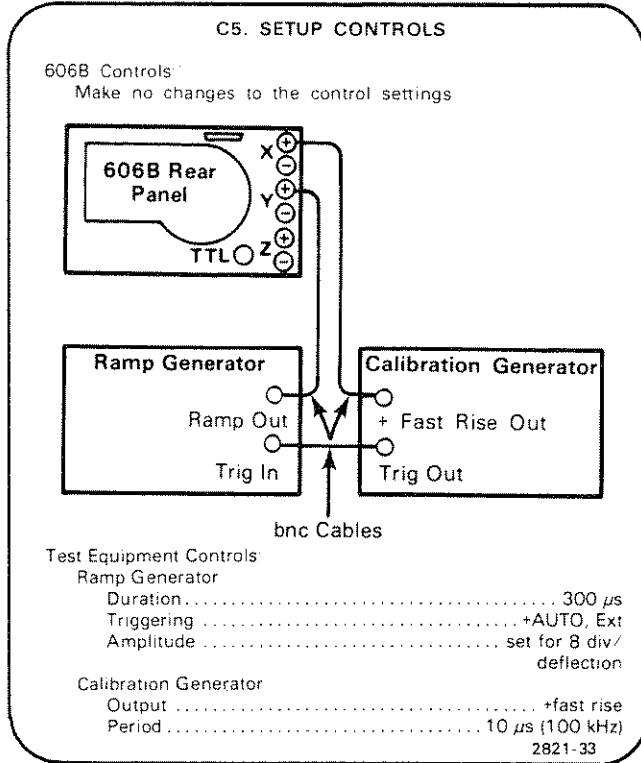

- Set the square wave amplitude to provide 8 cm of horizontal deflection while centering the display using the horizontal Position control.
- EXAMINE**—That the area after the front corner is flat, within a finely focused trace width (0.003 inch).
- Set the Ramp Generator to 10 μ s and increase the amplitude to provide 10 cm of horizontal deflection.
- CHECK**—That the time required for the leading edge of the square wave to travel from the zero percent level to the 100 percent level (see Fig. 5-3) is 500 ns (0.4 div.) or less, within a trace width (0.008 cm).

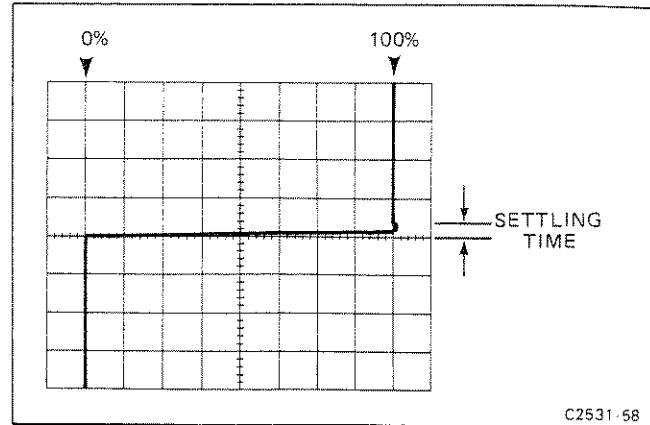
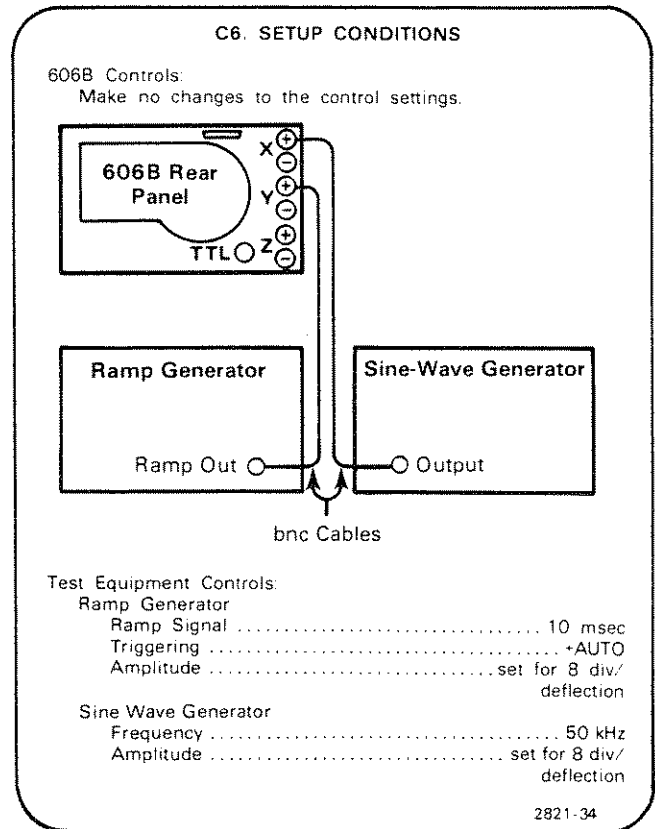

Figure 5-3. Typical crt display for horizontal settling time measurement.

C6. CHECK HORIZONTAL BANDWIDTH

NOTE

If the preceding step was not performed, first perform step C1, then proceed.



- Slowly increase the Sine-Wave Generator output frequency until the display amplitude is 5.6 divisions.
- CHECK**—That the Sine-Wave Generator frequency is at least 3 MHz.

C7. ADJUST HORIZONTAL (X) ATTENUATOR COMPENSATION (C103, C107) AND CHECK HORIZONTAL INPUT ATTENUATION

NOTE

If the preceding step was not performed, first perform step C1, then proceed.

Before performing the following procedure, set the Horizontal (X) Amplifier sensitivity (606B) for 1V/8cm deflection. (See Step C3.)

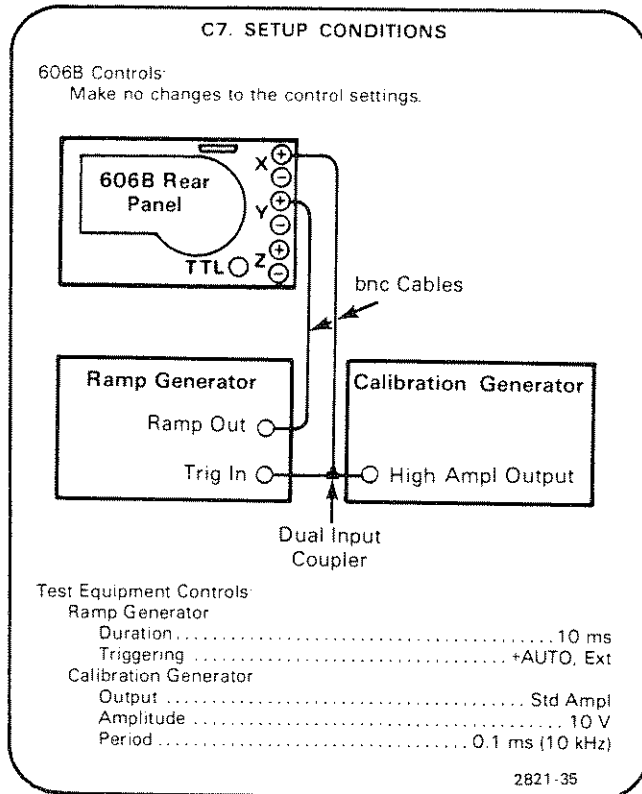

NOTE

In this step, the test oscilloscope is used as the amplitude measurement standard. The accuracy of the measurement of input attenuation is determined by the test Oscilloscope vertical sensitivity calibration.

- Verify that the Horizontal (X) Amplifier sensitivity is set for 1V/8cm deflection.
- Turn off the instrument POWER. Set the + and - atten switches (S100, S105) in the 5X position (back). Turn on the 606B POWER.
- Connect the Calibration Generator Std Ampl Output to the Vertical Input of the test oscilloscope through a 50 ohm terminator.

d. Set the test Oscilloscope deflection factor (Volts/Div) to 1 V/Div. Accurately set the test oscilloscope vertical gain for 5 divisions of deflection.

e. Change the Calibration Generator mode to High Ampl, and set the Period control to 1 ms (1 kHz). Set the Calibration Generator Pulse Amplitude for exactly five divisions of vertical deflection on the test oscilloscope (position as necessary).

f. Disconnect the Calibration Generator from the test Oscilloscope vertical input, and connect it (Calibration Generator High Ampl Output) through the dual input coupler to the +X INPUT connector on the 606B, and the external trigger input on the Ramp Generator.

g. Apply a positive-going 10 msec ramp of 1 volt amplitude to the +Y INPUT connector.

h. **CHECK**—For 8 divisions of horizontal deflection.

i. **ADJUST**—C103 (+X Atten Comp) for optimum square corner.

h. Disconnect the Calibration Generator from the +X INPUT and connect it to the -X INPUT. Install the grounding cap on the +X INPUT.

k. Center the display.

l. **ADJUST**—C107 (-X Atten Comp) for optimum square corner.

**C8. CHECK HORIZONTAL (X) COMMON
MODE REJECTION (1X, 5X ATTEN)**

NOTE

If the preceding step was not performed, first perform step C1, then proceed.

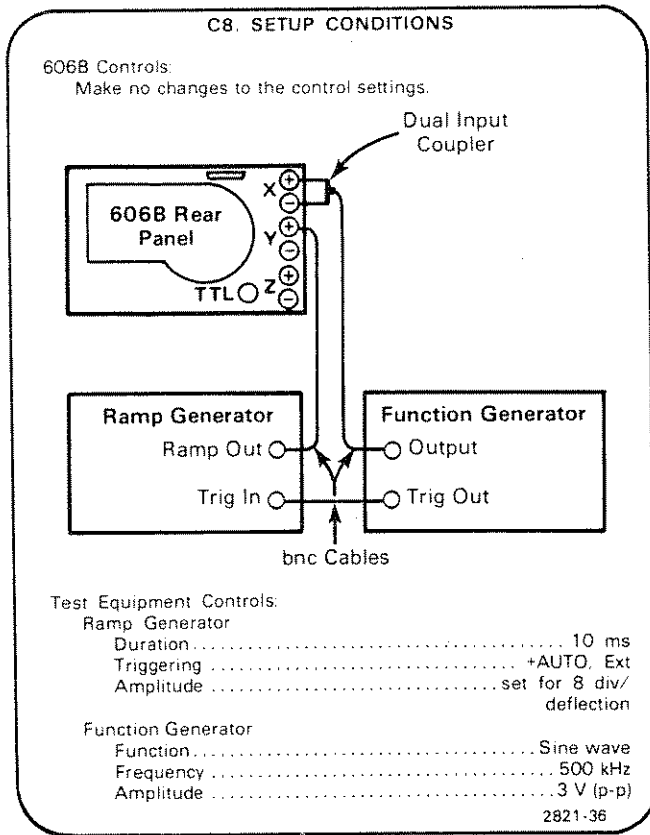

a. Turn off the 606B POWER. Move the 50 Ω/1 MΩ X INPUT Impedance Selecting Jumpers to the 1 MΩ position.

b. Turn on the 606B POWER.

c. Connect the Function Generator output to the test Oscilloscope vertical input. (Do not terminate).

d. Set the Function Generator controls for a 500 kHz, 3-volt (p-p) sinewave as indicated on the test Oscilloscope.

e. Disconnect the sine wave signal from the test Oscilloscope and connect it (using the dual-input coupler) to both the +X and -X INPUT connectors on the 606B.

f. **CHECK**—For 0.24 division, or less, of free running horizontal display on the 606B (position as necessary).

g. Turn off the 606B POWER. Set S100 (+X Atten) and S105 (-X Atten) to the 5X position (switches back).

h. Turn on the 606B POWER.

i. Repeat part c and d, then increase the Function Generator output to 15 volts (p-p).

j. Repeat part e.

k. **CHECK**—For 0.6 division, or less, of free-running horizontal display on the 606B (position as necessary).

l. Turn off the 606B POWER. Return S100 (+X Atten) and S105 (-X Atten) to the 1X (forward) position.

m. Change the input impedance to 50 Ω.

D. VERTICAL (Y) AMPLIFIER

Equipment Required: (Numbers correspond to those listed in Table 5-3, Test Equipment.)

- | | |
|-------------------------|-------------------------------------|
| 3. Ramp Generator | 11. Dual-Input Coupler (1 required) |
| 4. Calibrator Generator | 15. bnc cables (3 required) |
| 5. Sine-Wave Generator | 21. 9X magnifier |
| 10. Function Generator | |

D1. VERTICAL (Y) AMPLIFIER PRELIMINARY SETUP

a. Perform the Adjustment and Performance Check Power-Up Sequence given at the beginning of Part II—Adjustment and Performance Check.

b. Refer to Section 6, Instrument Options, and the Change Information at the rear of this manual for any modifications which may affect this procedure.

c. See **TEST POINT AND ADJUSTMENT LOCATIONS** and **INTERNAL CONTROL AND SELECTOR LOCATIONS** foldout pages in Section 8, Diagrams and Circuit Board Illustrations.

d. Set 606B controls:

INTENSITY Visible display
Vertical and Horizontal Position..... Midrange
FOCUS..... Well-defined display

D2. ADJUST Y AMPLIFIER GAIN (R204, R209, R229) AND CHECK POSITIONING

NOTE

Perform step D1, then proceed.

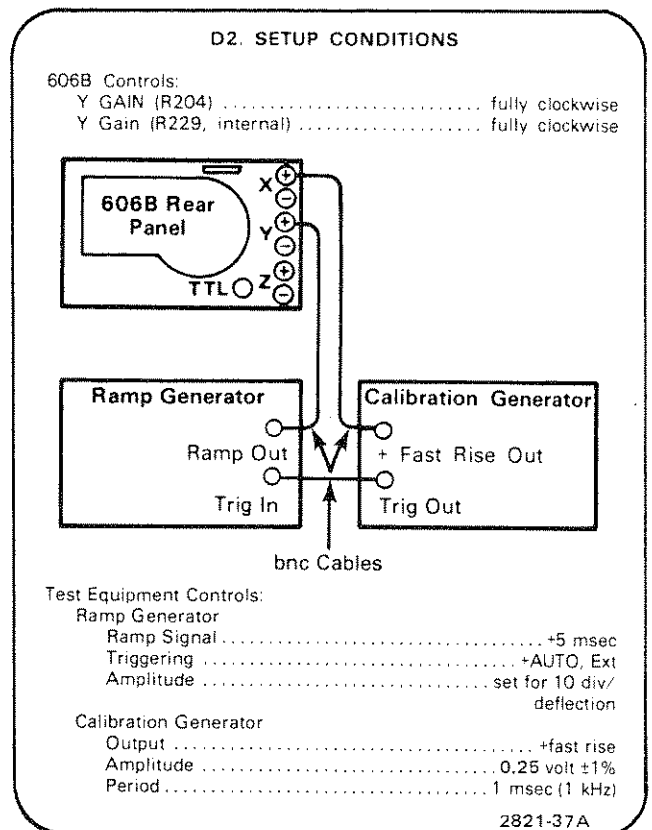

NOTE

This procedure adjusts all gain set controls (R204, R209, R229) for maximum sensitivity of the Vertical (Y) Amplifier. Normally, the Output Amplifier Gain (R209) will not be adjusted unless the X-Y Output Amplifier board has been serviced or the crt has been replaced.

The Calibration Generator output must be set within 1% nominally for the adjustment. Check that the input impedance selecting jumpers (P101, P105) are in the 50 Ω position.

WARNING

Up to 250 V dc at potentially lethal currents are present at the power transistor tabs and at other points on the X-Y Output Amplifier board. Use caution when servicing.

- a. Assure that attenuator switches (S200, S205) are in the 1X position and grounding caps are on all unused INPUTs.
- b. Position the display near vertical screen center.
- c. **EXAMINE**—For a crt display of exactly 4.5 cm amplitude.
- d. **ADJUST**—R209 (Output Amplifier Gain) located on the X-Y Output board for a crt display of exactly 4.5 cm amplitude.

NOTE

This adjustment standardizes the output amplifier gain, and must not be used for adjusting deflection sensitivity. Altering this adjustment will change HF Compensation and misadjustment may cause output amplifier saturation, resulting in poor off-screen recovery and degradation of settling time performance.

- e. **ADJUST**—Y GAIN (R204, front panel) for a crt display of exactly 4 cm of deflection.
- f. Disconnect the Calibration Generator from the Monitor.
- g. **CHECK**—Rotate the vertical Position control and check that the horizontal trace can be positioned vertically anywhere in the graticule area.

NOTE

The Vertical system is now adjusted to maximum sensitivity (0.5V/8cm). The internal Y Gain (R229, X-Y Pre-Amplifier board) may be readjusted for any deflection factor within specified limits (0.5V/8cm to ≥2.5V/8cm) by applying the desired input amplitude and adjusting for appropriate vertical deflection.

This instrument is factory adjusted for a deflection factor of 1V/8cm, within 2%.

D3. ADJUST Y AMPLIFIER COMPENSATION (C206, C208, C279, R203) AND EXAMINE SCAN LIMITER

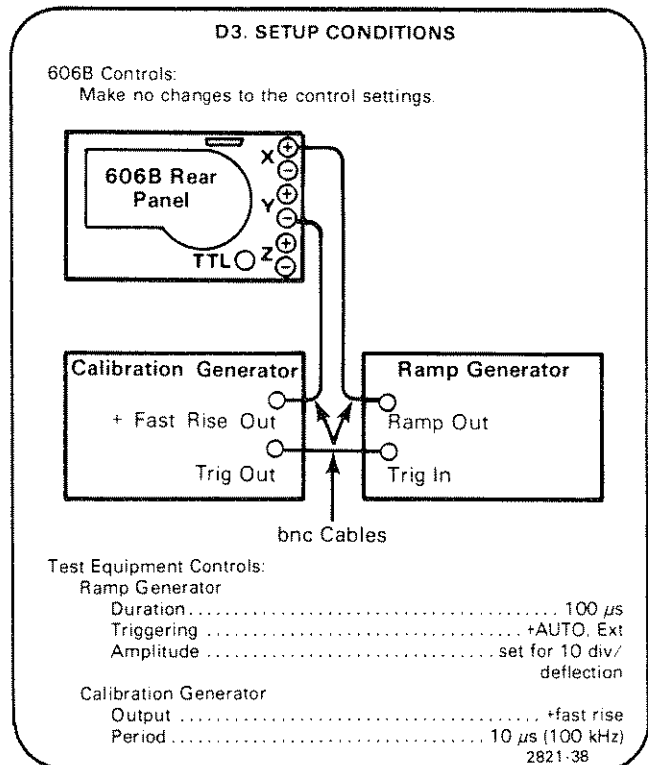

NOTE

The use of a hand magnifier of at least 5X is necessary for observing the square-wave front corner and flatness. The alignment tool must be a low capacitance, insulated type. Remove the tool from the adjustment screw before determining that the adjustment is optimum.

The capacitance shield must be in place for the following adjustments.

- a. Set the square-wave amplitude to provide 7.5 cm of vertical deflection, then center the display using the vertical Position control.
- b. Using the front panel FOCUS control, adjust the trace for optimum width while observing with the hand magnifier.
- c. **ADJUST**—C206 (HF Comp 1) and R203 (HF Comp 3) for optimum bottom leading corner.

NOTE

R203 affects the "sharpness" of the leading corner. Adjust so that the corner and the area just after is flat.

- d. Remove the square-wave from the -Y INPUT and apply it to the +Y INPUT. Install the grounding cap on the unused input. Center the display.
- e. **EXAMINE**—The front corner, and move C279 (HF Comp 2) slightly to verify that the corner is optimum.

NOTE

If C279 or the board was replaced, preset C279 to approximately 1/2 its adjustable length.

- f. **ADJUST**—C279 (HF Comp 2) for optimum front corner. (Use the hand magnifier for close observation).
- g. **INTERACTION**—Repeat steps c and f, adjusting C279 (HF Comp 2) for the top (+) corner and C206 (HF Comp 1) for the bottom (-) corner until both positive and negative going waveforms are optimum.

h. Increase the ramp duration to 3 ms and set the Calibration Generator period to 0.1 ms (10 kHz) to obtain about 4 cycles/cm.

- i. **ADJUST**—C208 for optimum front corner.
- j. Move C279 slightly to verify that the front corner is optimum.

NOTE

The last fine adjustment should be made with C279.

- k. Position the display slowly, above and below the graticule center, until 1 cm of display remains on the screen.
- l. **EXAMINE**—That no visible shift in front corner response occurs.

D4. CHECK VERTICAL SETTLING TIME

NOTE

If the preceding step was not performed, first perform step D1, then proceed.

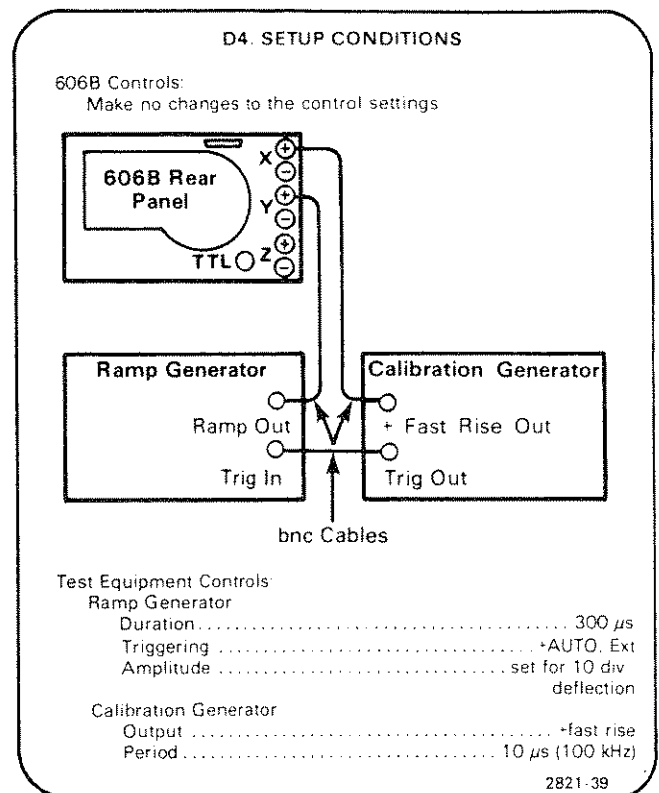

- a. Set the square wave amplitude to provide 8 cm of vertical deflection while centering the display using the vertical Position control.
- b. **EXAMINE**—That the area after the front corner is flat, within a finely focused trace width (0.003 inch).
- c. Set the Ramp Generator to 10 μ s.
- d. **CHECK**—That the time required for the leading edge of the square wave to travel from the zero percent level to the 100 percent level (see Fig. 5-4) is 500 ns (0.5 div.) or less, within a trace width (0.008 cm).

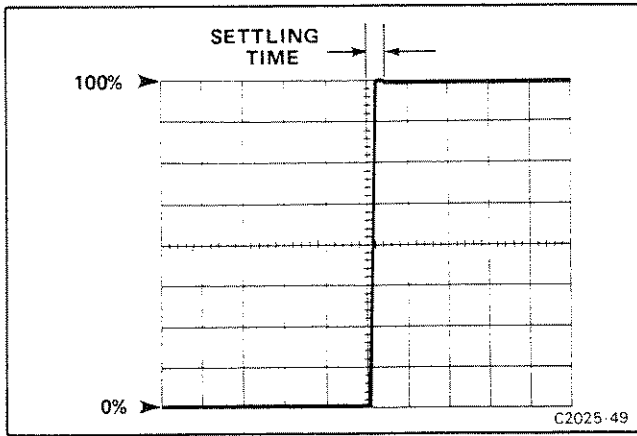
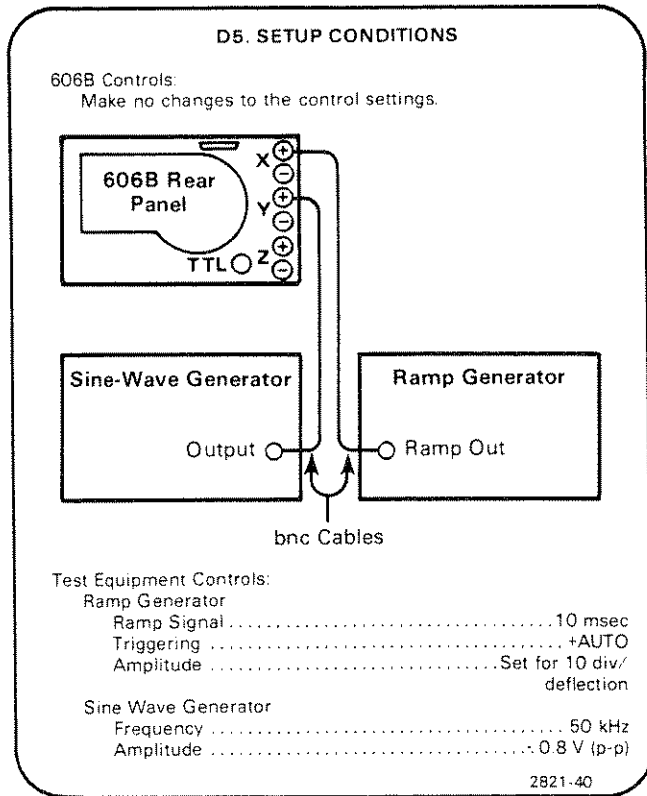

Figure 5-4. Typical crt display for vertical settling time measurement.

D5. CHECK VERTICAL BANDWIDTH

NOTE

If the preceding step was not performed, first perform step D1, then proceed.



a. Set the Sine-Wave Generator amplitude for 6 divisions of deflection.

b. Slowly increase the Sine-Wave Generator output frequency until the display amplitude is 4.2 divisions.

c. **CHECK**—That the Sine-Wave Generator is at least 3 MHz.

D6. ADJUST VERTICAL (Y) ATTENUATOR COMPENSATION (203, C207) AND CHECK VERTICAL INPUT ATTENUATION

NOTE

If the preceding step was not performed, first perform step D1, then proceed.

Before performing the following procedure, set the Vertical (Y) Amplifier sensitivity (606B) for 1V/8cm deflection. (See step D2.)

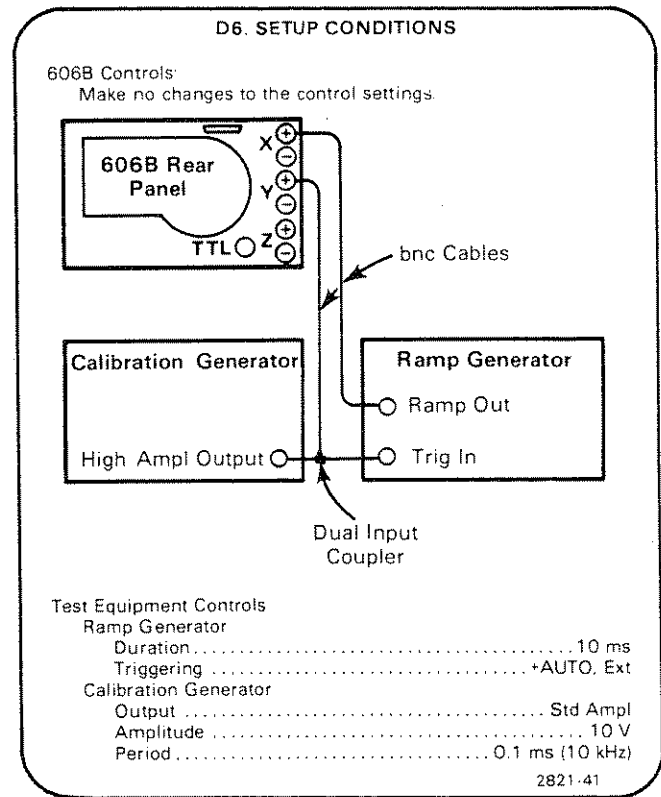

NOTE

In this step, the test Oscilloscope is used as the amplitude-measurement standard. The accuracy of the measurement of input attenuation is determined by the test Oscilloscope vertical sensitivity calibration.

a. Verify that the Vertical (Y) Amplifier sensitivity is set for 1V/8cm deflection.

b. Turn off the 606B POWER. Set the + and - Atten switches (S200, S205) in the 5X position (back). Turn on the 606B POWER.

c. Connect the Calibration Generator Std Ampl Output to the vertical input of the test Oscilloscope through a 50 ohm terminator.

d. Set the test Oscilloscope deflection factor (Volts/Div) to 1 V/Div. Accurately set the test Oscilloscope vertical gain for 5 divisions of deflection.

e. Change the Calibration Generator Mode to High Ampl, and set the Period control to 1 ms (1 kHz). Set the Calibration Generator Pulse Amplitude for exactly five divisions of vertical deflection on the test Oscilloscope. (position as necessary).

f. Disconnect the Calibration Generator from the test Oscilloscope vertical input, and connect it (Calibration Generator High Ampl Output) through the dual input coupler to the +Y INPUT connector on the 606B, and the external trigger input on the Ramp Generator.

g. **CHECK**—For 8 divisions of deflection.

h. **ADJUST**—C203 (+Y Atten Comp) for optimum square corner.

i. Disconnect the Calibration Generator from the +Y INPUT and connect it to the -Y INPUT. Install the grounding cap on the +Y INPUT.

j. Center the display.

k. **ADJUST**—C207 (-Y Atten Comp) for optimum square corner.

D7. CHECK VERTICAL (Y) COMMON MODE REJECTION (1X, 5X ATTEN)

NOTE

If the preceding step was not performed, first perform step D1, then proceed.

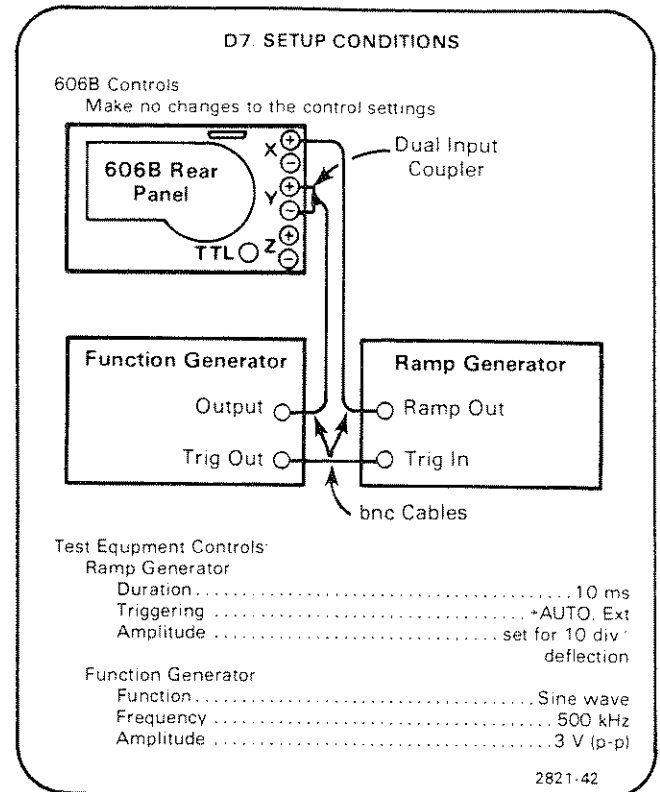

a. Move the 50 Ω /1 M Ω Y INPUT Impedance Selecting Jumpers to the 1 M Ω position.

b. Turn on the 606B POWER.

c. Connect the Function Generator output to the test Oscilloscope vertical input. (Do not terminate.)

d. Set the Function Generator controls for a 500 kHz, 3 volt (p-p) sine-wave as indicated on the test Oscilloscope.

e. Disconnect the sine wave signal from the test Oscilloscope and connect it (using the dual-input coupler) to both the +Y and -Y INPUT connectors on the 606B.

f. **CHECK**—For 0.24 division, or less, of free running vertical display on the 606B (position as necessary).

g. Turn off the 606B POWER. Set S200 (+Y Atten) and S105 (-Y Atten) to the 5X position (switches back).

h. Turn on the 606B POWER.

**Calibration Part II—606B
Adjustment and Performance Check**

- i. Repeat part c and d, then increase the Function Generator output to 15 volts (p-p).
- j. Repeat part e.
- k. **CHECK**—For 0.6 division, or less, of free-running vertical display on the 606B (position as necessary).
- l. Turn off the 606B POWER. Return S200 (+Y ATTEN) and S105 (-Y ATTEN) to the 1X (forward) position. Turn on the 606B POWER.

D8. CHECK PHASING

NOTE

If the preceding step was not performed, first perform step D1, then proceed.

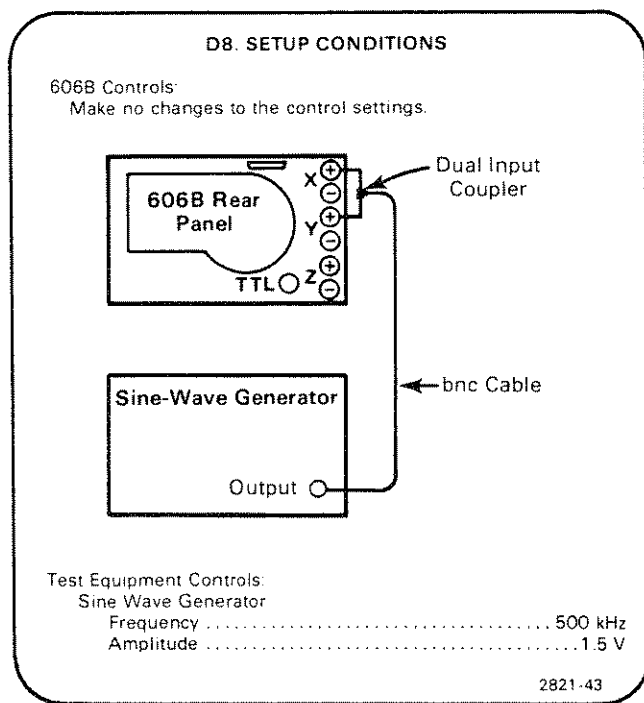

- a. Center the display within the graticule area.
- b. **CHECK**—That the diameter of the displayed ellipse, measured vertically at the center of the graticule, is 0.1 division or less.

NOTE

The following procedure sets Z-Axis Amplifier Gain for full intensity range from a +1 volt input. This procedure can be repeated for any voltage, up to +5 volts, to provide the desired intensity control range.

- a. Set the Calibration Generator Pulse Amplitude for 1 volt as indicated on the test Oscilloscope.
- b. Disconnect the 1-volt square wave from the test oscilloscope.
- c. Connect a 10X probe from the test Oscilloscope vertical input to TP280 (606B). Set the test Oscilloscope for dc input coupling and a deflection factor of 20 volts/div with the 10X probe.
- d. Set the INTENSITY control so that the trace on the 606B just disappears.
- e. Note the dc level on the test Oscilloscope (denotes Z-Axis cutoff level).
- f. Connect the 1 V square-wave signal to the +Z INPUT connector.
- g. **ADJUST**—R124 (Z-Axis Gain) so that the upper level of the square wave (displayed on the test Oscilloscope) is 70 volts higher than the cutoff level noted in step e.
- h. Check the 606B for a fully brightened trace.

E3. ADJUST Z-AXIS COMPENSATION (R239 AND C285) AND CHECK ABERRATIONS

NOTE

If the preceding step was not performed, first perform step E1, then proceed.

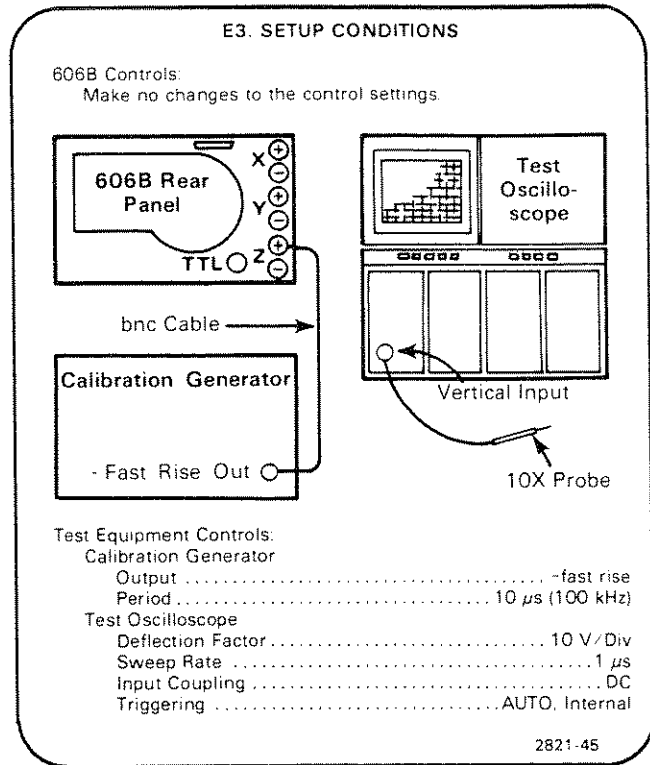

- a. Connect a 10X probe from the test Oscilloscope vertical input to TP280 (606B).
- b. Set the INTENSITY (606B) control and Calibration Generator amplitude for 60 Volts (6 divisions amplitude as indicated on the test Oscilloscope).
- c. **CHECK**—The square wave displayed on the test Oscilloscope for 0.6 divisions (3 volts) or less aberrations on the top front corner of the displayed pulse.

NOTE

Probes having an input capacitance greater than 4 pF will cause some front corner overshoot at higher output levels. A 3-5% overshoot at 70 V output is normal with probes having 10 pF capacitance.

- d. **ADJUST**—Preset HF Comp (R239, C285) to midrange. Adjust R239 for minimum aberrations and C285 for optimum front corner. (Use a low-capacitance screwdriver when adjusting C285).

e. **INTERACTION**—Repeat adjustments in part d for optimum square corner and minimum aberrations.

NOTE

Changing the adjustment of R239 or C285 may affect the check in E4 (Check Z-Axis Amplifier Bandwidth).

E4. CHECK Z-AXIS AMPLIFIER BANDWIDTH

NOTE

If the preceding step was not performed, first perform step E1, then proceed.

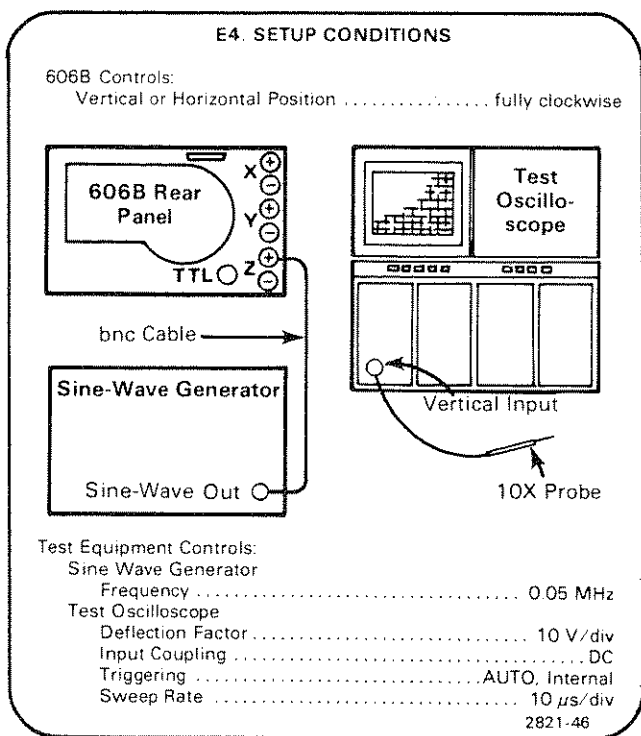

- Connect a 10X probe from the test Oscilloscope vertical input to TP280.
- Set the 606B INTENSITY control and the Sine-Wave Generator Amplitude for a 7-division (70 V) display on the test Oscilloscope. (Make sure no clipping occurs on the test Oscilloscope display.)
- Slowly increase the sine-wave generator output frequency until the display amplitude is 4.9 divisions on the test Oscilloscope.
- CHECK**—That the Sine-Wave Generator output frequency is at least 5 megahertz.
- INTERACTION**—If the check requirement in part d cannot be met, repeat the adjustments in step E3.

E5. CHECK Z-AXIS COMMON MODE REJECTION

NOTE

If the preceding step was not performed, first perform step E1, then proceed.

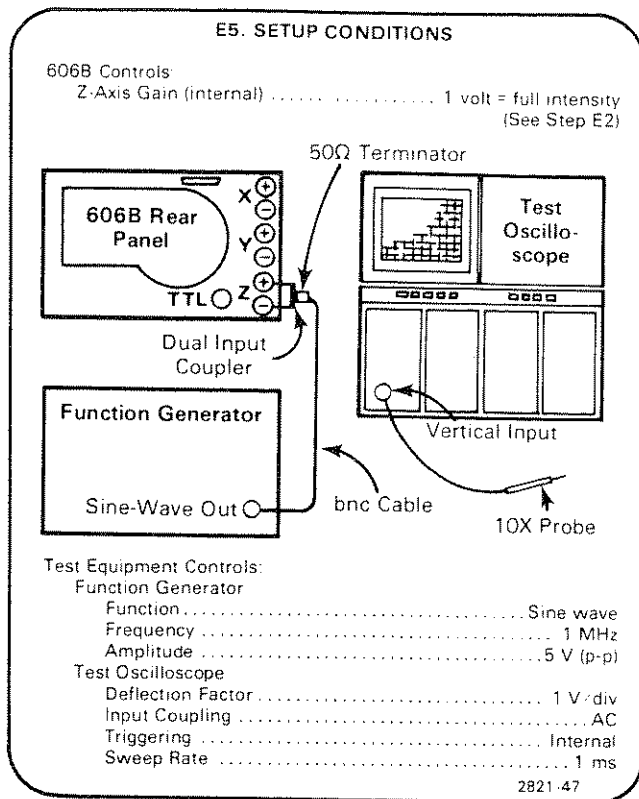

NOTE

The Z-Axis Gain must be set for 1 volt full intensity when performing this step. Input Impedance Selecting jumpers (P102, P106) are in the 1 M Ω position as shipped from the factory.

- Connect the 10X probe from TP280 to the vertical input of the test Oscilloscope.
- CHECK**—The test Oscilloscope for 3.5 divisions (3.5 V) or less.

E6. CHECK Z-AXIS BLANKING

NOTE

If the preceding step was not performed, first perform step E1, then proceed.

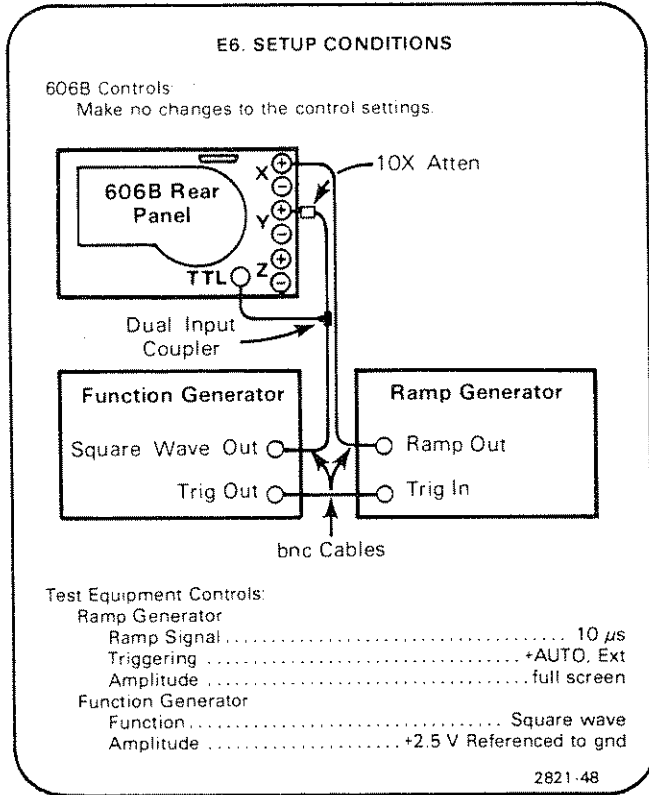

- a. Disconnect the signal to the Y INPUT.
- b. **CHECK**—That the full square-wave is visible. Connect the signal to the Y INPUT.
- c. Turn off the 606B. Move P176 and P179 to the LO (+) position.
- d. **CHECK**—That only the positive portion of the square wave is displayed.
- e. Turn off the 606B POWER. Move the jumpers (P176, P179) to the (-) position.
- f. **CHECK**—That only the negative portion of the square wave is displayed.

NOTE

The Blanking Level Selecting jumpers should remain in the LO (+) position for normal operation.

F. DYNAMIC FOCUS

Equipment Required: (Numbers correspond to those listed in Table 5-3, Test Equipment.)

- | | |
|--------------------------------|---------------------------------------|
| 1. Digital Voltmeter (DVM) | 9. Test Oscilloscope (with 10X probe) |
| 3. Ramp Generator (2 required) | 15. bnc cables (3 required) |
| 6. Dot Generator | 22. 24X Magnifier |

F1. DYNAMIC FOCUS PRELIMINARY SETUP

a. Perform the Adjustment and Performance Check Power-Up Sequence given at the beginning of Part II—Adjustment and Performance Check.

b. Refer to Section 6, Instrument Options, and the Change Information at the rear of this manual for any modifications which may affect this procedure.

c. See **TEST POINT AND ADJUSTMENT LOCATIONS** and **INTERNAL CONTROL AND SELECTOR LOCATIONS** foldout pages in Section 8, Diagrams and Circuit Board Illustrations.

d. Set 606B controls:

INTENSITY Visible display

Vertical and Horizontal

Position Position the dot
to center screen
(within 0.2 division)

F2. ADJUST BIAS (R306)

NOTE

Perform Step F1, then proceed.

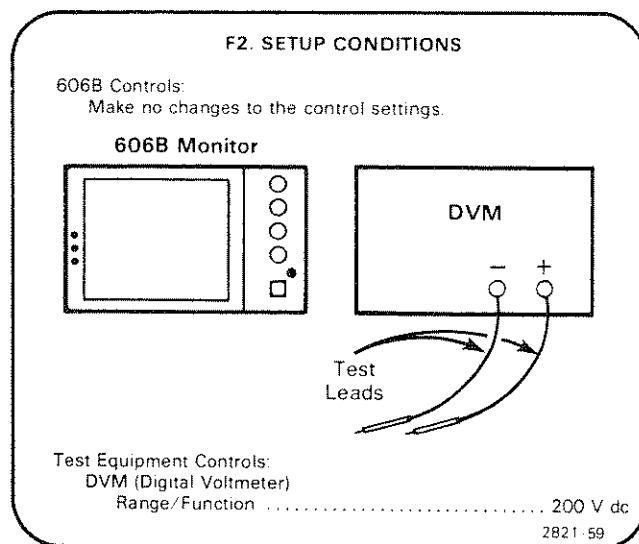

a. Connect the DVM between TP370 and ground.

b. **EXAMINE**—For a voltmeter reading between 42.5 V and 43.5 V.

c. **ADJUST**—R306 (Bias) for a voltmeter reading between 42.5 V and 43.5 V.

F3. ADJUST FOCUS AND STIGMATORS (WITH DOT GENERATOR)

NOTE

Perform Step F1, then proceed. If a dot Generator is unavailable, go to Step F4, Adjust Focus and Stigmators (Without Dot Generator).

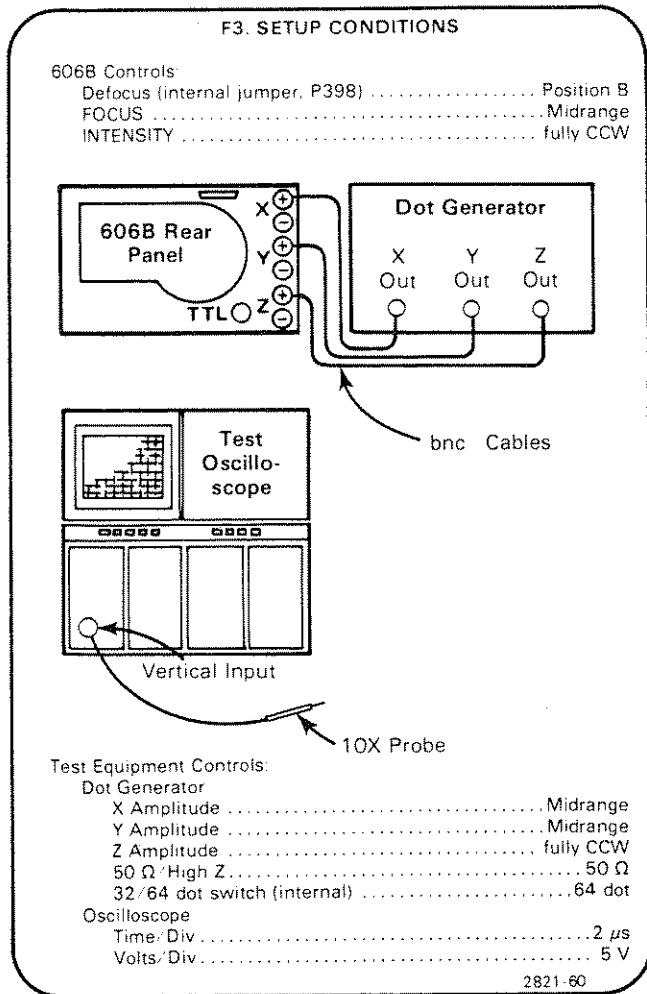

- a. Turn off the 606B POWER.
- b. Observe that the defocus jumper (P398) is in position B.
- c. Connect the test oscilloscope 10X probe to TP280 (Z-Axis output).
- d. Turn on the 606B POWER.
- e. Rotate the 606B INTENSITY control clockwise until 0 volt is measured at TP280, then rotate the Z-Amplitude (Dot Generator) clockwise until a pulse amplitude of 20 Volts is obtained (at TP280).
- f. Disconnect the Test Oscilloscope from the Monitor.

g. Provide a centered 7 × 9 division dot display on the 606B using the X and Y Amplitude controls (Dot Generator) and the horizontal and vertical Position controls (606B).

h. Set the FOCUS (R76, front panel) to midrange.

NOTE

For optimum performance, a hand magnifier of at least 5X should be used for viewing and ADJUSTing dots.

i. **ADJUST**—Coarse Focus (R125, located on High Voltage board) for smallest center dot.

j. Set the FOCUS (R76, front panel) fully counter-clockwise.

k. **ADJUST**—R385 (Center Stig 1) and R295 (Center Stig 2) for roundest center dot.

l. Locate the Stigmator 2 adjustments.

m. Observe right center edge¹ of screen.

n. **ADJUST**—R215 (Right, S2) for roundest² dot.

o. Observe left center edge of screen.

p. **ADJUST**—R205 (Left, S2) for roundest dot.

q. Observe top center edge of screen.

r. **ADJUST**—R225 (Top, S2) for roundest dot.

s. Observe bottom center edge of screen.

t. **ADJUST**—R235 (bottom, S2) for roundest dot.

u. Turn off the 606B POWER and move P398 (Defocus) jumper to position A.

v. Turn on the 606B POWER.

w. Adjust FOCUS (R76, front panel) for roundest center dot.

x. Observe right center edge of screen.

y. **ADJUST**—R415 (right, focus) for roundest dot.

z. Observe left center edge of screen.

¹“Edge” means “center of edge of 7 × 9 cm quality area”.

²At the edges and corners of the screen the defocused dot may be roughly triangular in shape. “Roundest” dot then means “most nearly equilateral”.

- aa. **ADJUST**—R405 (left, focus) for roundest dot.
- bb. Observe top center edge of screen.
- cc. **ADJUST**—R425 (top, focus) for roundest dot.
- dd. Observe bottom center edge of screen.
- ee. **ADJUST**—R435 (bottom, focus) for roundest dot.
- ff. Turn off the 606B POWER and move P398 (Defocus) jumper to position B.
- gg. Turn on the 606B POWER.
- hh. Turn the FOCUS (R76, front panel) fully counter-clockwise to defocus the dot.
- ii. Observe the top right corner of the 7 × 9 quality area.
- jj. **ADJUST**—R151 (top right, S1) for roundest dot.
- kk. Observe the other three corners.
- ll. **ADJUST**—R152 (Top left, S1), R161 (bottom left, S1), and R162 (bottom right, S1) for roundest dot in their respective corners.
- mm. At this point, corner focus may be further improved by slight compromises of edge S2 adjustments.
- nn. Turn off the 606B POWER.
- oo. Move P398 (Defocus) jumper to position A. Turn on the 606B POWER.
- pp. **ADJUST**—R76 (Focus, front panel) for roundest center dot.
- qq. Connect the Test Oscilloscope to TP280 (Z-Axis output).
- rr. Set the Dot Generator Amplitude to 1 V and adjust the 606B INTENSITY for 70 V at TP280.
- ss. **ADJUST**—R455 (Z Focus) for roundest dot.
- tt. Turn off the 606B POWER and. move P398 (Defocus) jumper to position B.

CAUTION

Always turn off the 606B POWER before turning off the Dot Generator. The INTENSITY control may be set to a level that will cause burning of the crt phosphor when the display is a single, stationary dot.

F4. ADJUST FOCUS AND STIGMATORS (WITHOUT DOT GENERATOR)

NOTE

Perform Step F1, then proceed. See Step F3 to Adjust Focus and Stigmators (With Dot Generator).

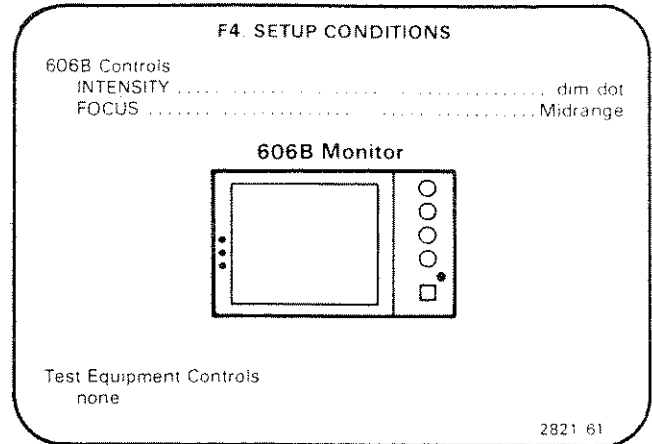

- a. Turn off the 606B POWER.
- b. Locate the Defocus jumper (P398) and check that it is in position B. Turn on the 606B POWER.
- c. Set the INTENSITY for a barely visible dot, and position it to center screen.
- d. Set the FOCUS (R76, front panel) to midrange.

NOTE

For optimum performance, a hand magnifier of at least 5X should be used for viewing and ADJUSTing dots.

- e. **ADJUST**—Coarse Focus (R125, located on High Voltage board) for smallest dot.
- f. Set the FOCUS (R76, front panel) fully counter-clockwise.
- g. **ADJUST**—R385 (Center Stig 1) and R295 (Center Stig 2) for roundest dot.
- h. Locate the Stigmator 2 adjustments.
- i. Move the dot to the right center edge¹ of screen.
- j. **ADJUST**—R215 (Right, S2) for roundest² dot.

¹“Edge” means “center of edge of 7 × 9 cm quality area”.

²At the edges and corners of the screen the defocused dot may be roughly triangular in shape. “Roundest” dot then means “most nearly equilateral”.

**Calibration Part II—606B
Adjustment and Performance Check**

- k. Move the dot to the left center edge of screen.
- l. **ADJUST—R205** (Left, S2) for roundest dot.
- m. Move the dot to the top center edge of screen.
- n. **ADJUST—R225** (Top, S2) for roundest dot.
- o. Move the dot to the bottom center edge of screen.
- p. **ADJUST—R235** (bottom, S2) for roundest dot.
- q. Turn off the 606B POWER and move P398 (Defocus) jumper to position A.
- r. Turn on the 606B POWER.
- s. Adjust FOCUS (R76, front panel) for roundest dot.
- t. Move the dot to the right center edge of screen.
- u. **ADJUST—R415** (right, focus) for roundest dot.
- v. Move the dot to the left center edge of screen.
- w. **ADJUST—R405** (left, focus) for roundest dot.
- x. Move the dot to the top center edge of screen.
- y. **ADJUST—R425** (top, focus) for roundest dot.
- z. Move the dot to the bottom center edge of screen.
- aa. **ADJUST—R435** (bottom, focus) for roundest dot.
- bb. Turn off the 606B POWER and move P398 (Defocus) jumper to position B.
- cc. Turn on the 606B POWER.
- dd. Turn the FOCUS (R76, front panel) fully counter-clockwise to defocus the dot.
- ee. Move the dot to the the top corner of the 7 × 9 quality area.
- ff. **ADJUST—R151** (top right, S1) for roundest dot.
- gg. Move the dot, in turn, to each of the other three corners.
- hh. **ADJUST—R152** (Top left, S1), R161 (bottom left, S1), and R162 (bottom right, S1) for roundest dot in their respective corners.

- ii. At this point, corner focus may be further improved by slight compromises of edge S2 adjustments.
- jj. Turn off the 606B POWER.
- kk. Move P398 (Defocus) jumper to position A. Turn on the 606B POWER.
- ll. **ADJUST—R76** (FOCUS, front panel) for roundest dot.
- mm. Connect the Monitor to the appropriate test equipment as illustrated in Figure 5-5.

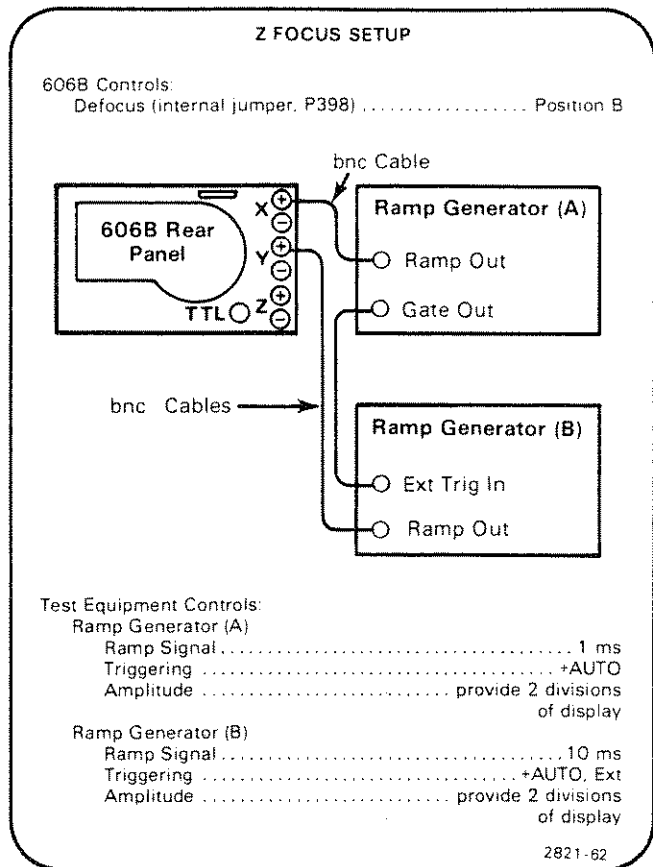

Figure 5-5. Adjust Focus and Stigmators (without Dot Generator)

- nn. Connect the DVM between TP280 (Z-Axis output) and ground.
- oo. Provide a synchronized, non-merged raster covering an area of 1 square inch on the screen.
- pp. Turn the INTENSITY control to obtain a 60 V reading at TP280.
- qq. **ADJUST—R455** (Z-Focus) for best focus.
- rr. Turn INTENSITY down.

F5. CHECK SPOT DIAMETER

NOTE

If the preceding step was not performed, first perform step F1, then proceed.

NOTE

The intensity is now set to approximately $3.5 \mu\text{W}/\text{cm}^2$. This setting is sufficiently accurate under normal circumstances for verification of the spot size, however, a photometer may be used if available.

Place the photometer probe against the face of the crt while displaying a 700 line, 7×9 cm raster. Rotate the INTENSITY until a reading of $3.5 \mu\text{W}/\text{cm}^2$ is read on the photometer.

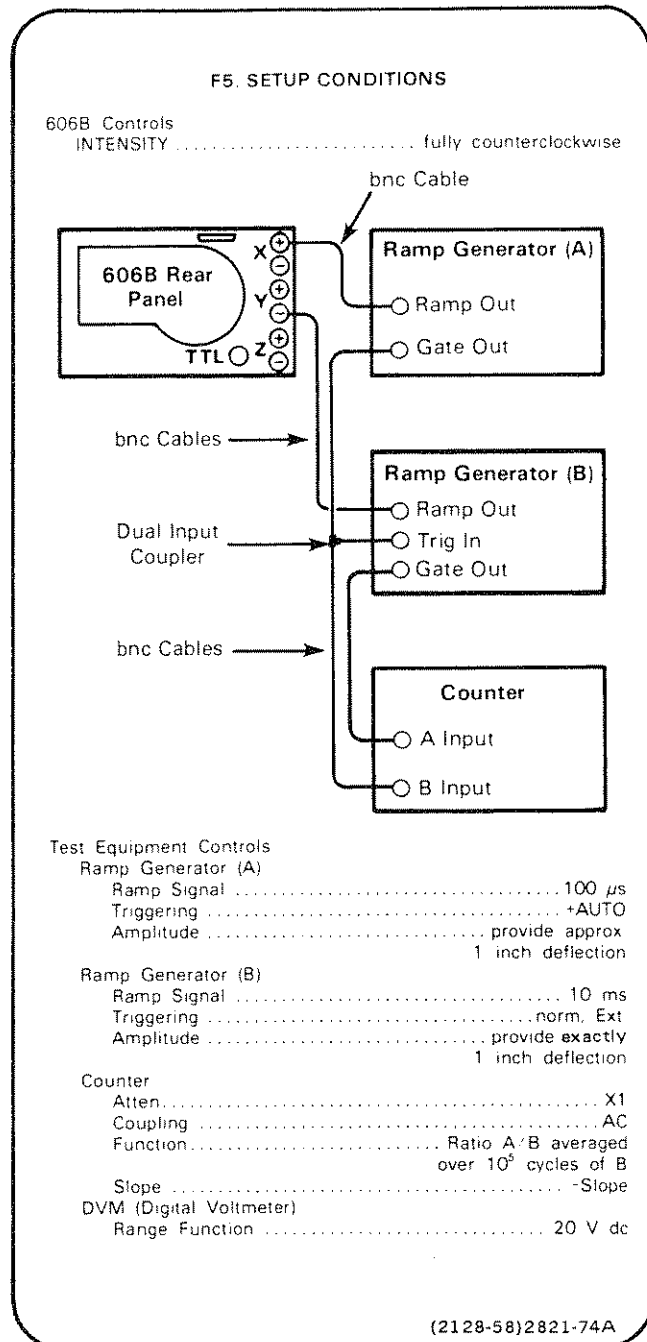

b. Disconnect the DVM. Do not move the INTENSITY control.

c. Using the Level control of Ramp Generator (A) provide a synchronized raster.

d. While viewing the raster with a 24X magnifier rotate the duration multiplier (Ramp Generator A) clockwise until the lines just merge to a uniform field.

e. Record the Counter reading.

f. Turn off the 606B POWER.

g. Interchange the 606B X and Y inputs (to check horizontal spot diameter).

h. Turn on the 606B POWER.

i. Set the amplitude of Ramp Generator B to provide exactly 1 inch of deflection.

j. Repeat part d.

k. CHECK—The average of the present Counter reading and the reading recorded in part e. The average of the two readings must be 0.0031 inch or less.

l. Turn off the 606B POWER.

m. Remove all test equipment from the Monitor.

a. Connect the DVM between TP280 (Z-Axis output) and ground. Rotate the INTENSITY control till a reading of +20 V is measured at TP280.

This completes Part II—Performance Check and Adjustment.

Free Manuals Download Website

<http://myh66.com>

<http://usermanuals.us>

<http://www.somanuals.com>

<http://www.4manuals.cc>

<http://www.manual-lib.com>

<http://www.404manual.com>

<http://www.luxmanual.com>

<http://aubethermostatmanual.com>

Golf course search by state

<http://golfingnear.com>

Email search by domain

<http://emailbydomain.com>

Auto manuals search

<http://auto.somanuals.com>

TV manuals search

<http://tv.somanuals.com>