

Instruction Manual

Tektronix

P6249
4 GHz 5X Active Probe
071-0538-03

www.tektronix.com

Copyright © Tektronix, Inc. All rights reserved.

Tektronix products are covered by U.S. and foreign patents, issued and pending. Information in this publication supercedes that in all previously published material. Specifications and price change privileges reserved.

Tektronix, Inc., P.O. Box 500, Beaverton, OR 97077

TEKTRONIX and TEK are registered trademarks of Tektronix, Inc.

TEKTRONIX, TEK, TEKPROBE, and SureFoot are registered trademarks, and SureToe, FlexLead, and KlipChip are trademarks of Tektronix, Inc.

WARRANTY

Tektronix warrants that the products that it manufactures and sells will be free from defects in materials and workmanship for a period of one (1) year from the date of shipment. If a product proves defective during this warranty period, Tektronix, at its option, either will repair the defective product without charge for parts and labor, or will provide a replacement in exchange for the defective product.

In order to obtain service under this warranty, Customer must notify Tektronix of the defect before the expiration of the warranty period and make suitable arrangements for the performance of service. Customer shall be responsible for packaging and shipping the defective product to the service center designated by Tektronix, with shipping charges prepaid. Tektronix shall pay for the return of the product to Customer if the shipment is to a location within the country in which the Tektronix service center is located. Customer shall be responsible for paying all shipping charges, duties, taxes, and any other charges for products returned to any other locations.

This warranty shall not apply to any defect, failure or damage caused by improper use or improper or inadequate maintenance and care. Tektronix shall not be obligated to furnish service under this warranty a) to repair damage resulting from attempts by personnel other than Tektronix representatives to install, repair or service the product; b) to repair damage resulting from improper use or connection to incompatible equipment; c) to repair any damage or malfunction caused by the use of non-Tektronix supplies; or d) to service a product that has been modified or integrated with other products when the effect of such modification or integration increases the time or difficulty of servicing the product.

THIS WARRANTY IS GIVEN BY TEKTRONIX IN LIEU OF ANY OTHER WARRANTIES, EXPRESS OR IMPLIED. TEKTRONIX AND ITS VENDORS DISCLAIM ANY IMPLIED WARRANTIES OF MERCHANTABILITY OR FITNESS FOR A PARTICULAR PURPOSE. TEKTRONIX' RESPONSIBILITY TO REPAIR OR REPLACE DEFECTIVE PRODUCTS IS THE SOLE AND EXCLUSIVE REMEDY PROVIDED TO THE CUSTOMER FOR BREACH OF THIS WARRANTY. TEKTRONIX AND ITS VENDORS WILL NOT BE LIABLE FOR ANY INDIRECT, SPECIAL, INCIDENTAL, OR CONSEQUENTIAL DAMAGES IRRESPECTIVE OF WHETHER TEKTRONIX OR THE VENDOR HAS ADVANCE NOTICE OF THE POSSIBILITY OF SUCH DAMAGES.



Table of Contents

General Safety Summary	v
Service Safety Summary	vii

Product Description

Options	1
Standard Accessories	1
Optional Accessories	2
Contacting Tektronix	3

Features and Accessories

Configuration

Probe Offset	11
--------------------	----

Functional Check

Deskew Fixture	15
Probe Calibration Errors	16
Check Compatibility	16
Check for Hardware Problems	17

Operating Basics

Handling the Probe	19
Maximum Non-destructive Input Voltage	19
Input Linear Dynamic Range	19
Ground Lead Length	20

Helpful Hints

Low-Inductance Grounding	23
SureFoot Grounding	24
Probe Tip Test Points	25

Specifications

Theory of Operation

Probe Head and Cable Assembly	36
Compensation Box	36
Offset Amplifier	36
Probe Identification EEPROM	36
TEKPROBE Interface	37
VCC, +7 V Regulator	37

Performance Verification

Equipment Required	39
Equipment Setup	40
Output Zero	41
DC Attenuation Accuracy	42
Rise Time	44

Adjustments

Adjustment Locations	49
Offset Zero	50
Offset Range	51

Maintenance

Replacing TEKPROBE Interface Pins	53
Removing and Replacing the Compensation Box Covers	54
Removing and Replacing the TEKPROBE Interface Collar	56
Inspection and Cleaning	57
Replacement Parts	57
Preparation for Shipment	57

Troubleshooting

Replaceable Parts

Parts Ordering Information	63
Using the Replaceable Parts List	64

List of Figures

Figure 1: Dynamic and offset limitations	12
Figure 2: Probe functional check connections	13
Figure 3: Deskew fixture connections (two P6249 probes shown)	15
Figure 4: Maximum frequency vs. measurement lead length ..	21
Figure 5: Low-inductance grounding	23
Figure 6: Using a SureFoot adapter for grounding	24
Figure 7: Using a probe tip as a test point	25
Figure 8: Typical input impedance and phase versus frequency	28
Figure 9: Typical bandwidth	29
Figure 10: P6249 simplified schematic diagram	35
Figure 11: TEKPROBE interface	37
Figure 12: Setup for output zero and DC attenuation accuracy	41
Figure 13: Test system rise time setup	44
Figure 14: Test system and probe rise time setup	45
Figure 15: P6249 adjustment locations	49
Figure 16: 1103 power supply offset voltage location	51
Figure 17: P6249 offset range setup	52
Figure 18: Replacing TEKPROBE interface pins	53
Figure 19: Removing the compensation box covers	54
Figure 20: Replacing the compensation box cover	55
Figure 21: Replacing the TEKPROBE interface collar	56
Figure 22: Compensation box test point locations	60
Figure 23: P6249 replaceable parts	65
Figure 24: P6249 standard accessories	66
Figure 25: P6249 optional accessories	68

Table of Contents

General Safety Summary

Review the following safety precautions to avoid injury and prevent damage to this product or any products connected to it. To avoid potential hazards, use this product only as specified.

Only qualified personnel should perform service procedures.

To Avoid Fire or Personal Injury

Connect and Disconnect Properly. Connect the probe output to the measurement instrument before connecting the probe to the circuit under test. Disconnect the probe input and the probe ground from the circuit under test before disconnecting the probe from the measurement instrument.

Observe All Terminal Ratings. To avoid fire or shock hazard, observe all ratings and markings on the product. Consult the product manual for further ratings information before making connections to the product.

Connect the ground lead of the probe to earth ground only.

Do Not Operate Without Covers. Do not operate this product with covers or panels removed.

Do Not Operate With Suspected Failures. If you suspect there is damage to this product, have it inspected by qualified service personnel.

Do Not Operate in Wet/Damp Conditions.

Do Not Operate in an Explosive Atmosphere.

Keep Product Surfaces Clean and Dry.

Safety Terms and Symbols

Terms in This Manual. These terms may appear in this manual:



WARNING. *Warning statements identify conditions or practices that could result in injury or loss of life.*



CAUTION. *Caution statements identify conditions or practices that could result in damage to this product or other property.*

Terms on the Product. These terms may appear on the product:

DANGER indicates an injury hazard immediately accessible as you read the marking.

WARNING indicates an injury hazard not immediately accessible as you read the marking.

CAUTION indicates a hazard to property including the product.

Symbols on the Product. These symbols may appear on the product:



CAUTION
Refer to Manual



Service Safety Summary

Only qualified personnel should perform service procedures. Read this *Service Safety Summary* and the *General Safety Summary* before performing any service procedures.

Do Not Service Alone. Do not perform internal service or adjustments of this product unless another person capable of rendering first aid and resuscitation is present.

Product Description

The Tektronix P6249 is a 4 GHz (probe only), 5X active FET probe with 1 pF input capacitance. The P6249 has a low input capacitance and high input resistance which minimize circuit loading over a wide bandwidth range. The small profile and low-mass head of the P6249 make probing crowded circuits by hand fast and easy. The accessory tips and adapters included with the probe enable the P6249 to be used on a wide variety of circuit architectures.

The P6249 is powered through a TEKPROBE interface between the probe compensation box and the oscilloscope. The P6249 can be used with non-TEKPROBE oscilloscopes and instruments by using the optional Tektronix 1103 Probe Power Supply.

Options

The following options are available when ordering the P6249 probe:

- Option D1 – Calibration Data
- Option C3 – 3 years Calibration Service
- Option D3 – 3 years Calibration Data
- Option R3 – 3 years Extended Warranty

Standard Accessories

The P6249 is shipped with the following standard accessories:

- Standard probe tips
- SureFoot adapter probe tips
- SureToe adapter probe tips
- SMT KlipChip microcircuit test leads
- Y-lead adapter

- Right-angle adapter
- Three-inch ground lead
- Low-inductance ground pogo pin
- Color marker bands
- SMK4 Micro KlipChip adapters
- .100" square pin adapter
- Instruction manual

Optional Accessories

The following accessories are available for the P6249 probe:

- Deskew fixture
- Probe tip-to-SMA adapter
- 1103 Probe Power Supply
- Compensation box release tool
- Insulated adjustment tool

Refer to *Features and Accessories* on page 5 for more information on using the probe and accessories.

For part number information for standard and optional accessories, refer to *Replaceable Parts* on page 63.

Contacting Tektronix

Phone	1-800-833-9200*
Address	Tektronix, Inc. Department or name (if known) 14200 SW Karl Braun Drive P.O. Box 500 Beaverton, OR 97077 USA
Web site	www.tektronix.com
Sales support	1-800-833-9200, select option 1*
Service support	1-800-833-9200, select option 2*
Technical support	Email: techsupport@tektronix.com 1-800-833-9200, select option 3* 6:00 a.m. – 5:00 p.m. Pacific time

* This phone number is toll free in North America. After office hours, please leave a voice mail message. Outside North America, contact a Tektronix sales office or distributor; see the Tektronix web site for a list of offices.

Features and Accessories

The P6249 is provided with several features and accessories designed to make probing and measurement a simpler task. Please familiarize yourself with these items and their uses.

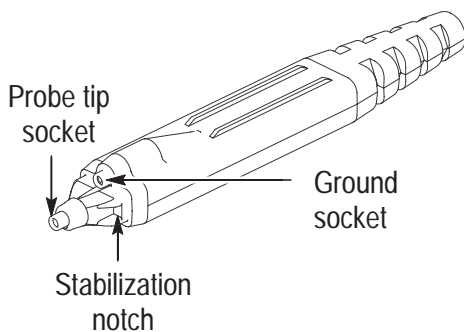

Probe head assembly. The probe head is designed for ease of use and high performance. Its small size makes it easy to handle in tight areas.

The probe tip socket is sized to easily press onto 0.025 inch pins for direct access. The ground socket provides a short ground path for high fidelity ground connections.

The stabilization notch permits you to use adjacent pins to reduce stresses on the probe and pins.

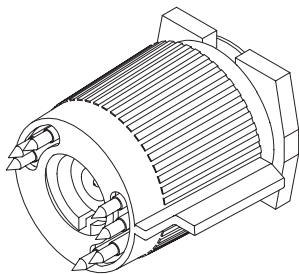

TEKPROBE Interface. The TEKPROBE interface provides a communication path between the probe and the oscilloscope. Contact pins provide power, signal, offset, and probe characteristic data transfer. See page 37 for more information.

If your oscilloscope does not support the TEKPROBE interface, you can use the optional 1103 probe power supply as an effective interface. Contact your local Tektronix representative for more information.

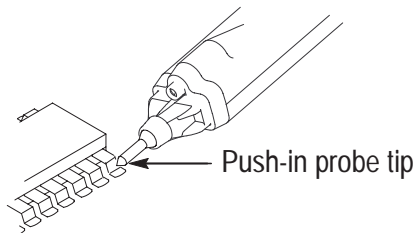

Push-in probe tip. Use the push-in probe tip for general purpose probing by hand. The tip may also be used as a temporary test point. See page 25 for more information.

The push-in probe tip may also be used with the other socketed leads and adapters.

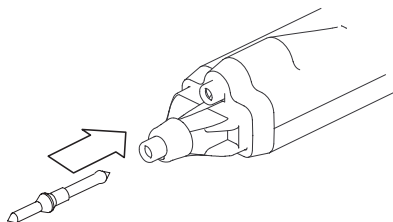

Installing the push-in probe tip. Attach the push-in probe tip by seating the tip into the probe tip socket and pushing the tip in until it is seated. Either end of the tip may be used.

Do not force the tip. Also, be careful not to poke yourself with the sharp probe-tip. To remove the tip, *gently* grab the tip with small pliers and pull the tip out.

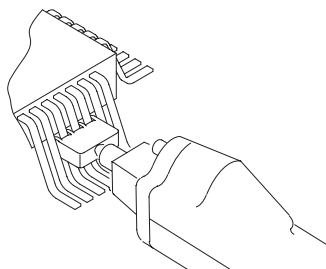

SureFoot probe tip. The SureFoot tip is an integral probe tip and miniature guide that enables fault-free probing of fine-pitch SMD packages. Attach SureFoot adapters the same way as the push-in probe tips. They can be used with any of the socketed accessory leads.

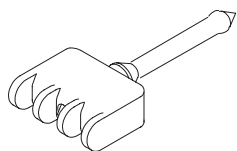

The orange, 0.050 inch SureFoot tip is compatible with 50 mil JEDEC packages such as SOIC, PLCC, CLCC, etc.

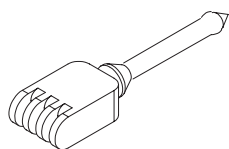

The blue, 0.025 inch SureFoot tip is compatible with 0.65 mm JEDEC and EIAJ packages.

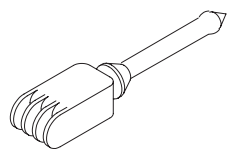

The red, 0.5 mm SureFoot tip is compatible with EIAJ packages.

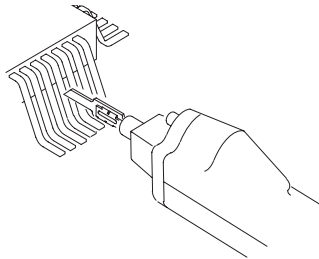

SureToe probe tip. The SureToe tip is a pointed probe tip useful for probing in dense circuitry. Attach the SureToe adapters the same way as the push-in probe tips. *Do not force the tip.* Also, be careful not to poke yourself with the sharp probe tip. They can be used with any of the socketed accessory leads.

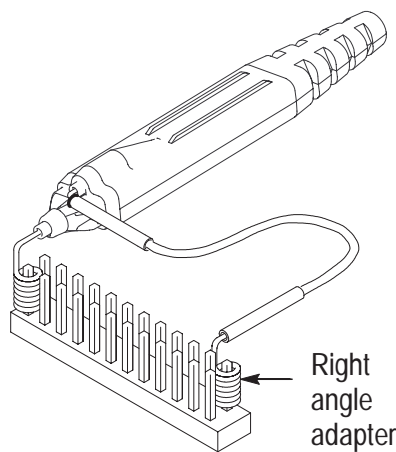

Right-angle adapter. Use the right-angle adapter for low-profile probing of 0.025 inch diameter square pins.

The right-angle adapter allows the probe to lie flat against a circuit board. This enables probing in vertical circuits such as computer or communications backplanes, or in tight areas such as between circuit cards.

The right-angle adapter can be used directly with the probe head, or attached to the Y-lead adapter or ground leads.

The right-angle adapter is attached the same way as the push-in probe tip, and can be easily removed by hand.

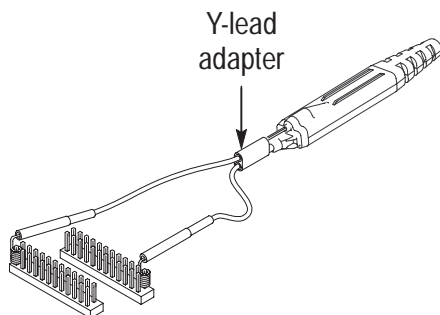

Y-lead adapter. Use the Y-lead adapter to extend the physical reach of the probe and ground when necessary. The Y-lead adapter accepts any of the probe tips or adapters, and can be pushed directly onto 0.025 inch pins.

When selecting the grounding connection, maintain as short a ground path as possible. Refer to page 20 for more information.

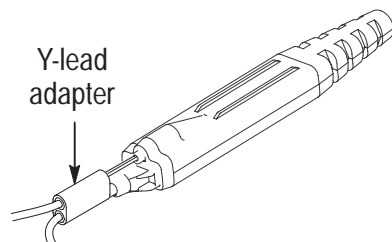

To attach the Y-lead adapter, gently press the lead pins into the probe head tip and ground receptacles. Using the black lead for ground is recommended.

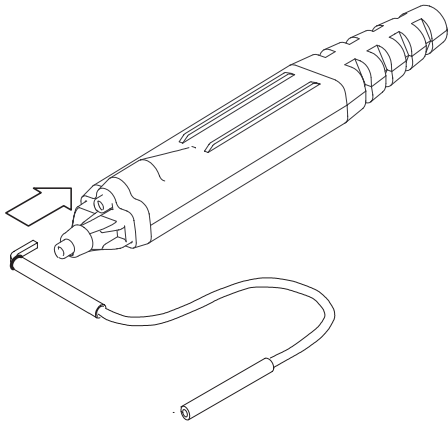

Three-inch ground lead. Use the three-inch ground lead for general probing. The socketed end of the lead may be connected to any of the probe tips and adapters or fitted onto 0.025 inch pins.

To attach the ground lead, press and rotate the lead pin connector into the ground socket on the probe head. The lead may be removed by simply pulling the pin out by hand.

When selecting the grounding connection, maintain as short a ground path as possible. Refer to page 20 for more information.

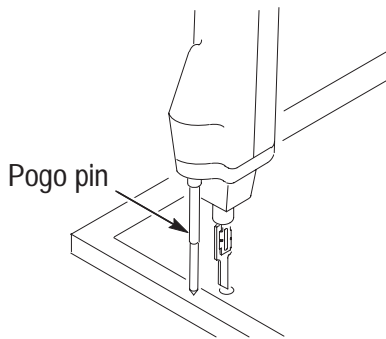

Low-inductance ground pogo pin. Use the low-inductance ground pogo pin to substantially reduce ground lead inductance. Because the pogo pin simply touches the ground reference, you can easily move the probe to different points on the circuit under test.

To attach, press the pogo pin into the probe head ground socket.

When selecting the grounding connection, maintain as short a ground path as possible. Refer to page 20 for more information.

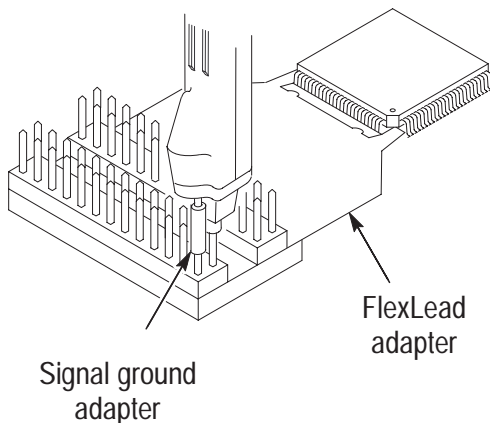

Signal-Ground Adapter. The signal-ground adapter is ideal for use with signal/ground pairs on 0.100 inch header pins (such as FlexLead adapters).

Attach the signal-ground adapter by gently pressing it into the ground socket on the probe head.

Be sure to use the stabilization notch whenever possible, to avoid slipping and damaging the probe or circuitry under test.

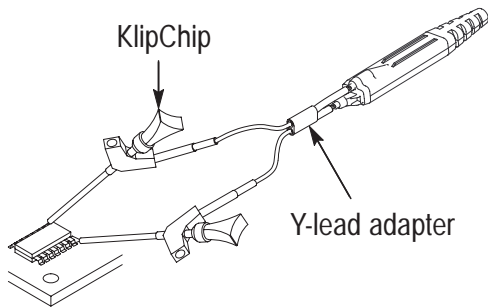

SMT KlipChip. Use the SMT KlipChip test clips to access fragile, dense circuitry.

KlipChip test clips can be connected to the Y-lead or three-inch ground leads. Simply press the lead socket into the KlipChip handle.

The KlipChip body freely turns, allowing better probe orientation. To reduce stress and provide a lower profile on components being tested, the flexible sleeve of the KlipChip bends up to a 35 degree angle.

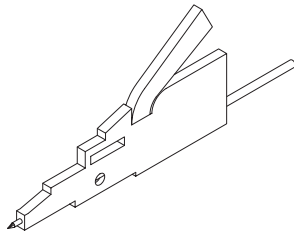

SMK4 Micro KlipChip adapters. Use the adapters to probe the leads on integrated circuits that are surface-mounted.

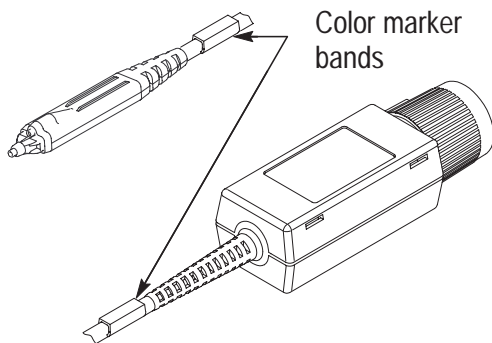

Color marker bands. Attach matching pairs of the color marker bands onto the cable at the head and compensation box of each probe. The marker bands enable quick verification of which probe is connected to which instrument channel.

Configuration

The P6249 provides the oscilloscope with the probe model number, serial number, and attenuation factor. When connected to an oscilloscope with a TEKPROBE interface, display readouts are corrected for the probe attenuation factor, the instrument input is set to 50 Ω , and the coupling is set to DC.



CAUTION. Do not attempt to install the P6249 on a non-TEKPROBE connector. Damage to the probe and connector may result. If your oscilloscope does not support the TEKPROBE interface, use the optional Tektronix 1103 Probe Power Supply.

If the P6249 is used with the Tektronix 1103 Probe Power Supply, be sure to have a 50 Ω termination at the oscilloscope. Also, set the oscilloscope channel coupling to DC.

The probe offset control is controlled by the oscilloscope. If the oscilloscope used does not support the TEKPROBE interface, use the offset controls on the optional Tektronix 1103 Probe Power Supply.

Probe Offset

The probe offset is adjustable to permit operation within the linear range of the probe. Using the offset to cancel DC signal components enables optimal probe performance. See Figure 1 on page 12 for more information.

NOTE. See your oscilloscope manual for specific instructions on its operation and offset control.

To set the probe offset, follow these steps:

1. Set the oscilloscope coupling to **GND**.
2. Use the vertical position control to set a zero reference level on the oscilloscope display.
3. Set the oscilloscope coupling to **DC** and **5 V/div**.
4. Attach the probe to the circuit.
5. Adjust the probe offset to bring the trace to the oscilloscope zero reference.
6. Change the volts/division setting to the desired range, adjusting the offset to keep the trace on the zero reference level.

NOTE. The P6249 has a ± 5.0 V offset range. The linear operating range is ± 2.0 V. See Figure 1. Also, see page 19 for more information.

If cursors are used on a TEKPROBE oscilloscope, the zero reference will be at the probe offset voltage.

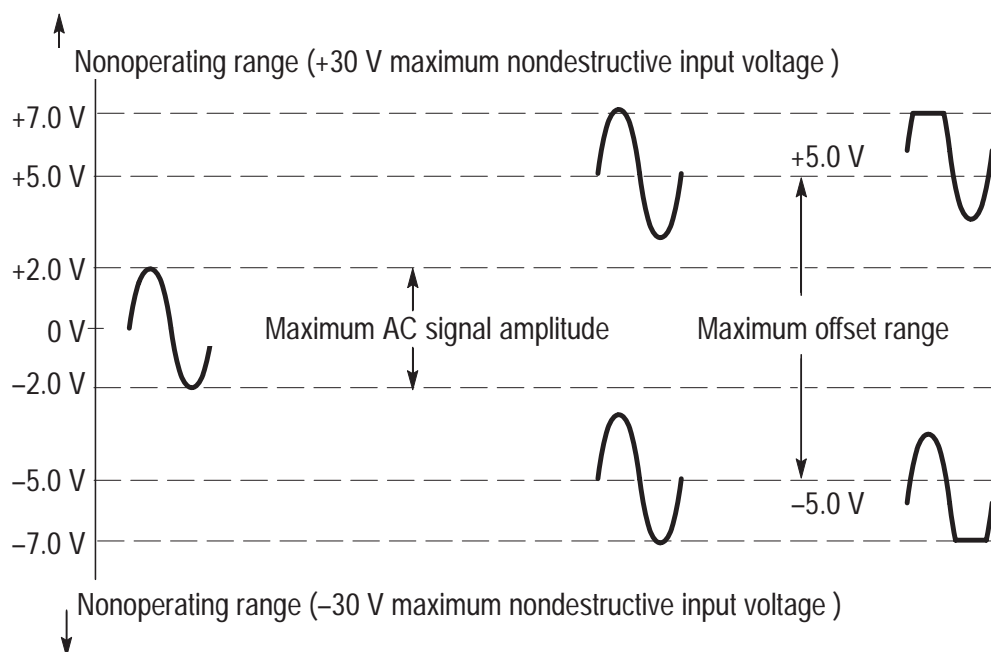

Figure 1: Dynamic and offset limitations

Functional Check

After installing the probe on the oscilloscope, a functional check may be performed using the PROBE COMPENSATION connections on the front panel of the oscilloscope. Use the optional deskew fixture for optimum connections. See Figure 2.

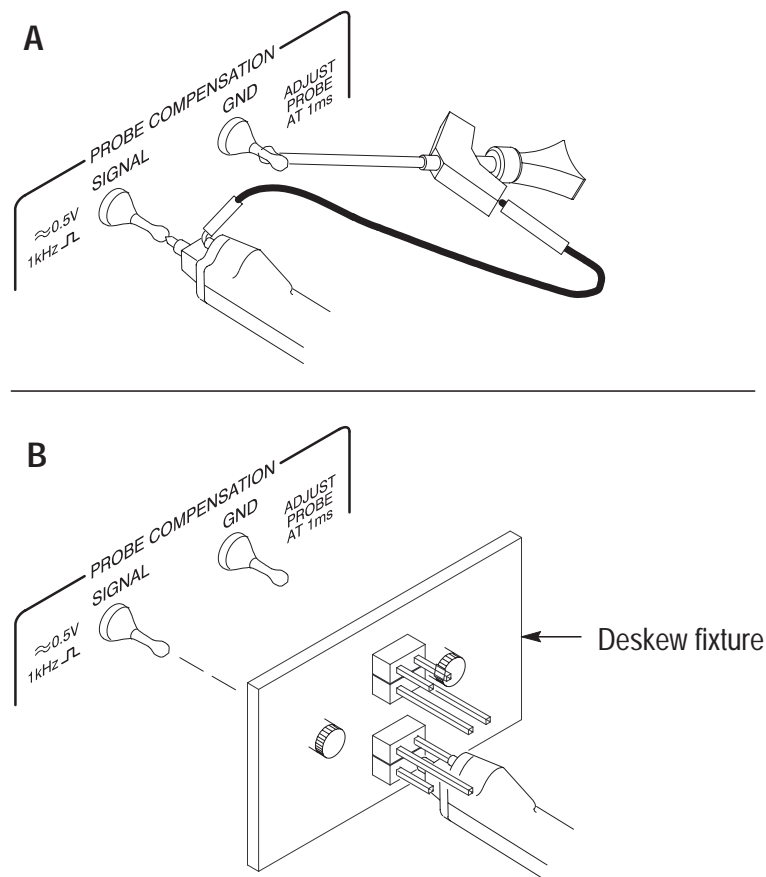

Figure 2: Probe functional check connections

1. Connect the probe to the oscilloscope.
2. Set the oscilloscope to display the probe channel.

3. If you have the optional deskew fixture, connect it to the PROBE COMPENSATION connections. Connect the probe to the deskew fixture (see Figure 3 on page 15), and proceed to step 6.
4. Using a ground lead and a SMT KlipChip, connect the probe ground to the PROBE COMPENSATION ground connection on the oscilloscope.
5. Using a standard tip, hold the probe to the SIGNAL terminal on the oscilloscope.
6. Adjust the oscilloscope to display a stable calibration waveform.

NOTE. *If your instrument supports probe calibration routines, now is a good time to perform them. However, certain firmware versions of TDS series oscilloscopes will return a “Probe Cal Failed” message. If this occurs, refer to Probe Calibration Errors on page 16.*

7. Disconnect the probe from the deskew fixture or SIGNAL terminal and ground the probe tip. (Connect the KlipChip to the probe tip.)
8. With the probe offset set to 0.0 V, the oscilloscope display should be at the ground reference.
9. Set the oscilloscope volts/division to 1 V.
10. Adjust the probe offset. The displayed waveform should vary between approximately +2.0 V and –2.0 V.

NOTE. *If no waveform is displayed, check the vertical coupling to be sure that it is set to DC.*

If the offset adjustment has no effect, set the vertical coupling to DC.

If you are using the Tektronix 1103 Probe Power Supply, and the waveform is distorted, check to make sure that the oscilloscope termination is 50 Ω .

If the probe does not pass this functional check, go to *Troubleshooting* on page 59.

Deskew Fixture

The optional deskew fixture provides a convenient way to connect the probes in your system to the calibration signal for deskewing. The deskew fixture is configured to allow you to connect different probe models to the system. Refer to Figure 3 to see how two P6249 probes are connected.

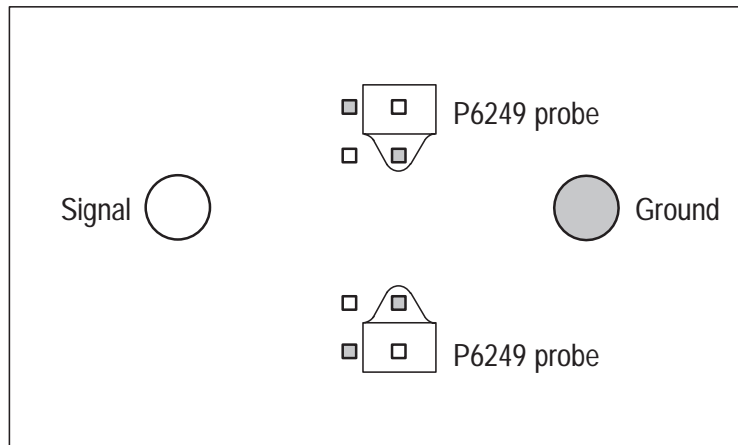

Figure 3: Deskew fixture connections (two P6249 probes shown)

For part number information for the deskew fixture, refer to *Replaceable Parts* on page 63.

Probe Calibration Errors

If you get the message “Probe Cal Failed”, or other calibration anomalies occur, you may be using an oscilloscope that is not fully compatible with the P6249 probe, or you may have a hardware problem.

Check Compatibility

Before suspecting a problem with your probe, compare your oscilloscope firmware version with those listed in Table 1.

Table 1: TDS 500, 600, or 700 series oscilloscopes fully compatible with the P6249 probe

Model number	Firmware version required
TDS 520D	greater than FV:6.3e
TDS 540D	greater than FV:6.3e
TDS 580D	greater than FV:6.3e
TDS 654C	FV:5.1e or above
TDS 680C	FV:5.1e or above
TDS 684C	FV:5.1e or above
TDS 694C	all versions compatible
TDS 724D	greater than FV:6.3e
TDS 754D	greater than FV:6.3e
TDS 784D	greater than FV:6.3e
TDS 794D	greater than FV:6.3e

NOTE. You can take P6249 probe measurements with any TDS 500, 600, or 700 series oscilloscope, regardless of firmware version. The fully compatible oscilloscopes listed in Table 1 give you enhanced accuracy after successfully passing the probe calibration function.

Other TDS 500, 600, or 700 series oscilloscopes may give the error message “Probe Cal Failed” when you run the probe calibration function, but the probe will still meet its warranted specifications.

Check for Hardware Problems

If the firmware version on your TDS 500, 600, or 700 series oscilloscope is fully compatible with the P6249 probe, do the following:

1. Perform the Signal Path Calibration on the oscilloscope and wait for it to complete.
2. Rerun the calibration routine on the P6249 probe.
3. If the oscilloscope returns the failure message again, initialize the probe calibration and check probe offset zero:
 - If offset zero is greater than ± 25 mV, perform the *Offset Zero* adjustment on page 50 in the *Adjustments* section.
 - If offset zero is less than ± 25 mV, check the *Offset Range* as instructed on page 51 in the *Adjustments* section.
4. Rerun the probe calibration function on the P6249 probe. If the probe calibration fails, run the calibration on another oscilloscope channel.
5. If the problem persists, there is a hardware fault. Please contact your nearest Tektronix Service Center for more information.

Operating Basics

Please follow these operating guidelines to get optimum performance from your P6249.

Handling the Probe

Exercise care when using and storing the P6249. The probe and cable are susceptible to damage caused by careless use. Always handle the probe using the compensation box and probe head, avoiding undue physical strain to the probe cable, such as kinking, excessive bending, or pulling. Visible dents in the cable will increase signal aberrations. Do not drop the probe or subject it to physical shock. Damage to the probe may result.

Maximum Non-destructive Input Voltage

The P6249 is electrically protected against static voltage; however, applying voltages above its design limits may damage the probe tip amplifier. Please refer to *Specifications* on page 27 for the maximum operating voltage and frequency derating information.

Input Linear Dynamic Range

The probe head amplifier used by the P6249 has a limited linear operating range. To keep the input linearity error less than 0.1% you must limit the apparent signal input voltage to ± 2.0 V.

Use the DC offset adjustment to maintain the probe within its dynamic range. The nominal offset adjustment range of the P6249 is ± 5.0 VDC. For example: to offset a +2 VDC level in a circuit, set the offset to +2 V.

NOTE. *The probe can tolerate input voltages of ± 30 V without damage; however, the linearity error specification does not apply to input voltages exceeding ± 7.0 V (including any DC offset). See Figure 1 on page 12.*

Ground Lead Length

When you are probing a circuit, you should always use as short a ground lead as possible between the probe head and circuit ground. When you touch your probe tip to a circuit element, you are introducing a new resistance, capacitance, and inductance into the circuit. This represents the characteristics of your probe and ground lead.

You can determine if ground lead effects may be a problem in your application if you know the self-inductance (L) and capacitance (C) of your probe and ground lead path. A portion of the ground lead path is uncontrollable since it is hard-wired on the circuit board under test.

As a guide, refer to Figure 4 to estimate the maximum frequency you can measure using additional lead length.

The total inductance can be calculated, with reference to the measurement loop area formed by the ground lead path, using the following formula:

$$L = \frac{A}{113} \quad \begin{array}{l} A = \text{Measurement loop area in square inches} \\ L = \text{Inductance in microhenries} \end{array}$$

Once you have calculated the inductance, use 1 picofarad for the capacitance of the P6249 and calculate the approximate resonant frequency (f_0) at which this parasitic circuit will resonate, using the following formula:

$$f_0 = \frac{1}{2\pi \sqrt{LC}}$$

The preceding equation shows that reducing the ground lead inductance will raise the resonant frequency. If your measurements are affected by ringing, your goal is to lower the inductance of your ground path until the resulting resonant frequency is *at least 3 times greater than the frequency of your measurements*.

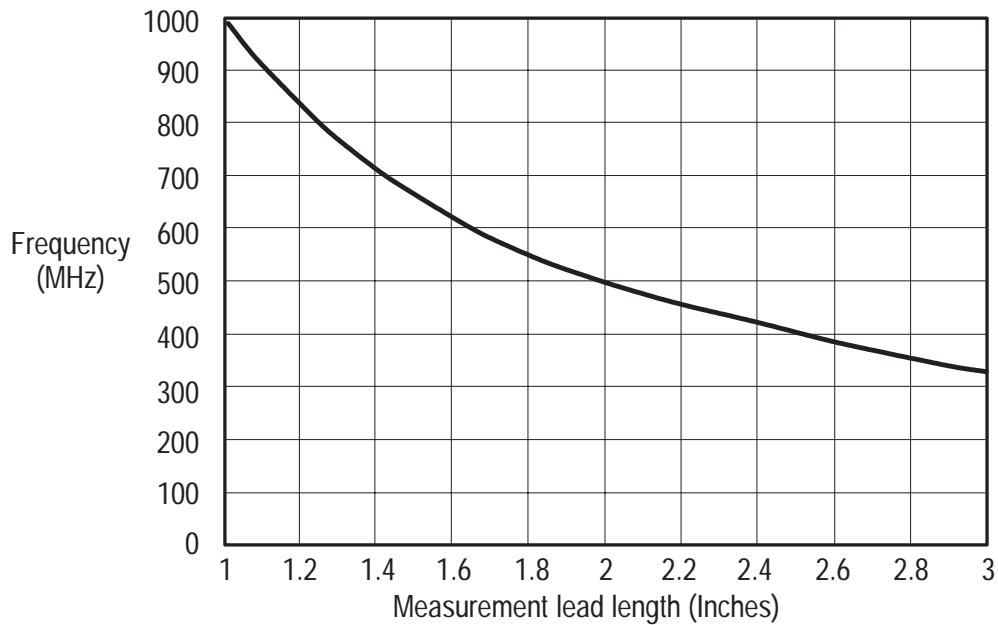

Figure 4: Maximum frequency vs. measurement lead length

In order to reach two test points with a P6249, a 2-inch length return ground lead is used. What is the maximum circuit frequency which should be measured?

Using the graph shown in Figure 4 as a guide, a 2-inch lead length yields a 500 MHz maximum frequency.

The low-inductance ground contacts described in *Accessories* on page 5 can help you reduce the effects of ground lead inductance on your measurements.

Helpful Hints

Follow these helpful hints to make probing easier and noise free.

Low-Inductance Grounding

Placing a ground plane on top of a package being probed can minimize ground lead length and inductance. See Figure 5.

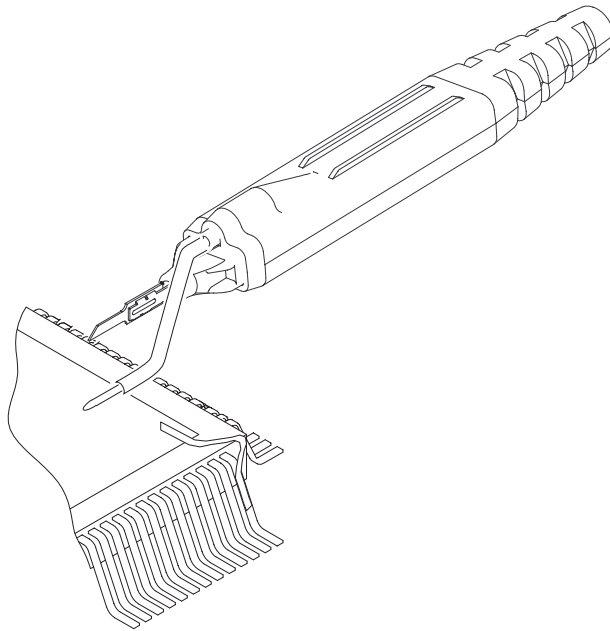

Figure 5: Low-inductance grounding

Attach a small piece of copper clad on top of the package and connect it to the package ground connection. Use the low-inductance ground lead provided with the P6249 to keep the ground lead length as short as possible.

This method is very useful when making many measurements on the same package. Using a ground plane on the package makes probing the package easier and avoids adding unnecessary ground lead length and distortion.

SureFoot Grounding

If you cannot use the recommended low-inductance grounding method, you may ground the probe to the package under test using a SureFoot adapter. Refer to Figure 6.

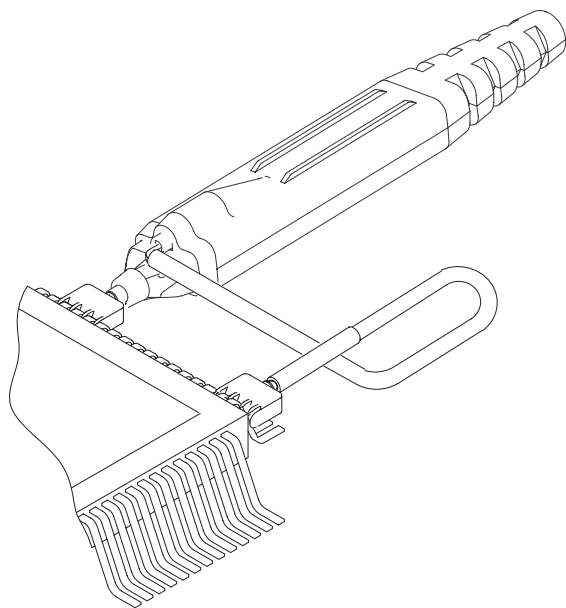

Figure 6: Using a SureFoot adapter for grounding

Use a SureFoot adapter at the end of a short ground lead to connect directly to the package ground. This method is preferred over using an adjacent circuit ground because it is the shortest ground path possible.

Probe Tip Test Points

You can solder the push-in probe tip or a 0.025 square pin to a circuit, to be used as a temporary test point. See Figure 7.

Solder the tip onto a lead or pin with a low-power soldering iron. Press the probe head onto the tip to make a measurement, and then pull the probe head off when you are done.

The probe tip may be removed and reused by desoldering it from the circuit, and soldering it into another circuit in the future.

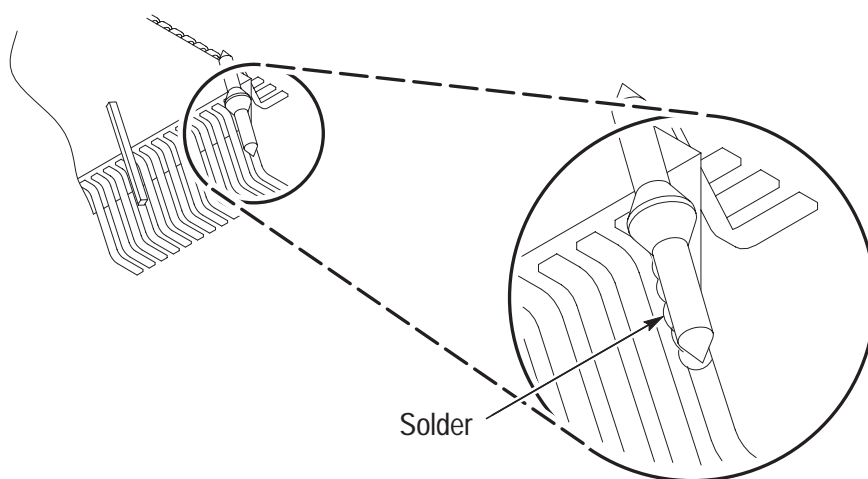

Figure 7: Using a probe tip as a test point

NOTE. Do not use pieces of solid-core copper wire be used as test points. If the wire breaks off in the probe tip socket, it may be impossible to remove the wire, and it will prevent insertion of other accessory tips.

Specifications

These specifications apply to a P6249 probe when used with a TDS 694C oscilloscope.

The probe and oscilloscope must first be allowed to warm up for 20 minutes before measurements are taken.



CAUTION. Do not apply voltages beyond the non-destructive input voltage range to the probe. Damage to the probe or circuit under test may result.

Table 2: Warranted electrical specifications

DC Attenuation Accuracy (probe only)	0.2 ±2% (excludes offset error)
Output Zero	±10 mV or less at output of probe
Rise Time (probe only)	≤120 ps

Table 3: Typical electrical characteristics

Bandwidth, (probe only)	4 GHz (See Figure 9)
Linear Input Dynamic Range	-2.0 V to +2.0 V. (Equivalent to -0.4 V to +0.4 V at the output of the probe.)
Linearity	± 0.1% over a dynamic range of -1.75 V to +1.75 V ± 1.0% over a dynamic range of -2.0 V to +2.0 V
Nondestructive Input Voltage Range	-30 V to +30 V (DC + peak AC)
Input Resistance	20 kΩ at DC. (See Figure 8)
Input Capacitance	1.0 pF

Table 3: Typical electrical characteristics (Cont.)

Offset Range	-5.0 V to +5.0 V
DC Offset Drift	150 $\mu\text{V}/^\circ\text{C}$ or less at output of probe 0.75 mV/ $^\circ\text{C}$ or less displayed on screen with TEKPROBE interface
DC Offset Scale Accuracy	$\pm 2\%$ (of 5X actual probe gain)
Delay Time	5.05 ns ± 0.2 ns
System Noise	300 μV rms or less at output of probe with probe tip grounded

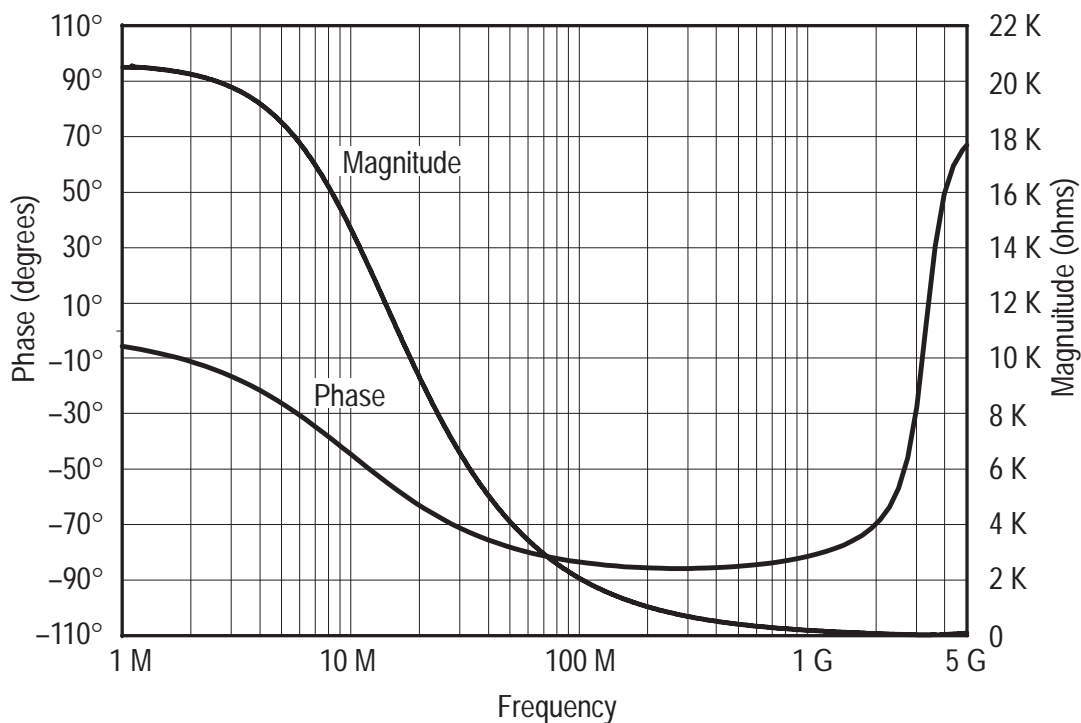
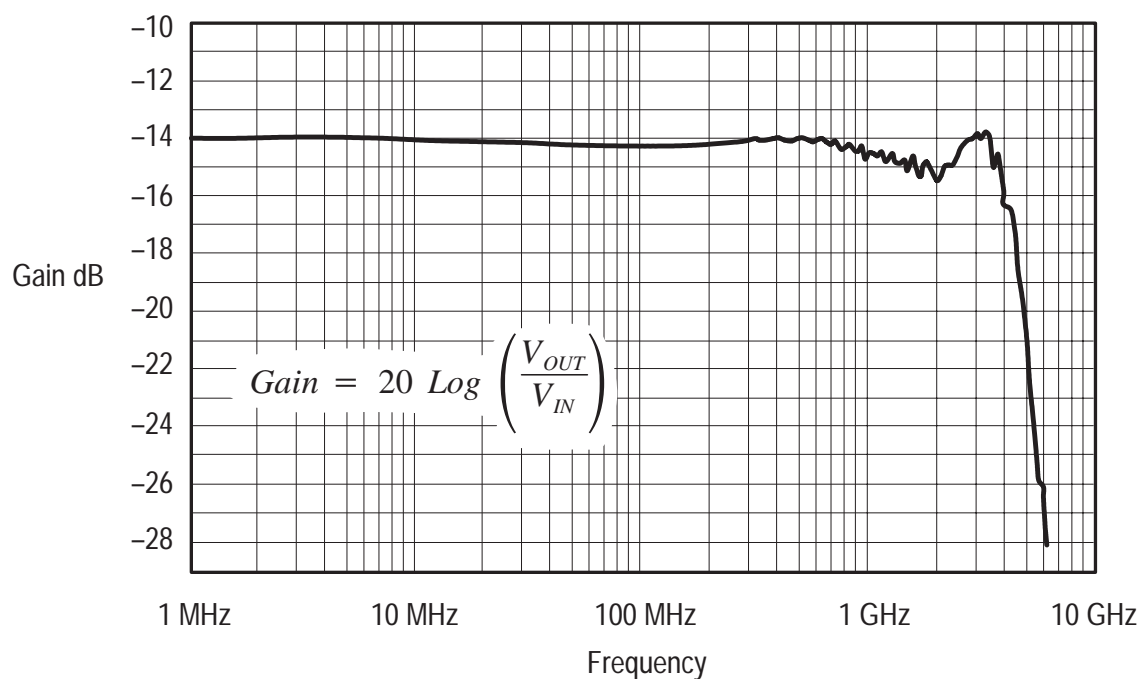

Figure 8: Typical input impedance and phase versus frequency

Table 4: Physical Characteristics

Net Shipping Weight	1.78 kg (3.93 lb)
Cable Length	1.3 meters

**Figure 9: Typical bandwidth****Table 5: Environmental characteristics**

Operating Temperature	0° C to +40° C. The environmental exposure is the procedure stated in Tektronix Design Standard 062-2847-00 for Class 5 equipment.
Nonoperating Temperature	-40° C to +71° C. The environmental exposure is the procedure stated in Tektronix Design Standard 062-2847-00 for Class 5 equipment.

Table 5: Environmental characteristics (Cont.)

Humidity	80% RH at 40° C. The environmental exposure is as stated in Tektronix Design Standard 062-2847-00 for Class 5 equipment.
Packaged Product Vibration and Shock	The packaged product qualifies under the Distribution Cycle 1 Assurance Level II for packaged products 0 to 20 lbs. Test 2 for Warehouse and Vehicle Stacking (Compression) is omitted. Tektronix standard 062-2858-00, Rev. B, Class 5.
Electrostatic Immunity	IEC 61000-4-2
EMC	IEC 801-3
Altitude	Operating: 15,000 ft. Non-Operating: 50,000 ft.
Pollution Degree	Pollution Degree 2

Table 6: Certifications and compliances

Category	Standards or description
EC Declaration of Conformity – EMC	Meets intent of Directive 89/336/EEC for Electromagnetic Compatibility. Compliance was demonstrated to the following specifications as listed in the Official Journal of the European Union: EN 55011 Class A Radiated and Conducted Emissions EN 55011 Class B Radiated and Conducted Emissions EN 61000-3-2 AC Power Line Harmonic Emissions EN 61000-3-3 AC Power Line Flicker

Table 6: Certifications and compliances (cont.)

Category	Standards or description
	EN 50082-1 Immunity: IEC 61000-4-2 Electrostatic Discharge Immunity IEC 61000-4-3 RF Electromagnetic Field Immunity IEC 61000-4-4 Electrical Fast Transient/Burst Immunity IEC 61000-4-5 Power Line Surge Immunity IEC 61000-4-6 Radio Frequency Common Mode IEC 61000-4-8 Power Frequency Magnetic Field IEC 61000-4-11 Voltage Dips and Interruptions
Australia/New Zealand Declaration of Conformity – EMC	Complies with EMC provision of Radiocommunications Act per the following standard(s): AS/NZS 2064.1/2 Industrial, Scientific, and Medical Equipment:1992 AS/NZS 3548 Information Technology Equipment: 1995
EMC Compliance	Meets the intent of Directive 89/336/EEC for Electromagnetic Compatibility when it is used with the product(s) stated in the specifications table. Refer to the EMC specification published for the stated products. May not meet the intent of the directive if used with other products.
FCC Compliance	Emissions comply with FCC Code of Federal Regulations 47, Part 15, Subpart B, Class A Limits.

Table 6: Certifications and compliances (cont.)

Category	Standards or description
Pollution Degree	<p>A measure of the contaminates that could occur in the environment around and within a product. Typically the internal environment inside a product is considered to be the same as the external. Products should be used only in the environment for which they are rated.</p> <p>Pollution Degree 1 No pollution or only dry, nonconductive pollution occurs. Products in this category are generally encapsulated, hermetically sealed, or located in clean rooms.</p> <p>Pollution Degree 2 Normally only dry, nonconductive pollution occurs. Occasionally a temporary conductivity that is caused by condensation must be expected. This location is a typical office/home environment. Temporary condensation occurs only when the product is out of service.</p>



WARNING

The following servicing instructions are for use only by qualified personnel. To avoid injury, do not perform any servicing other than that stated in the operating instructions unless you are qualified to do so. Refer to all Safety Summaries before performing any service.

Theory of Operation

There are no user replaceable parts within the probe or the compensation box; however, this theory of operation is provided to assist you in isolating failures to either the probe or the host oscilloscope. Refer to Figure 10 for the simplified schematic.

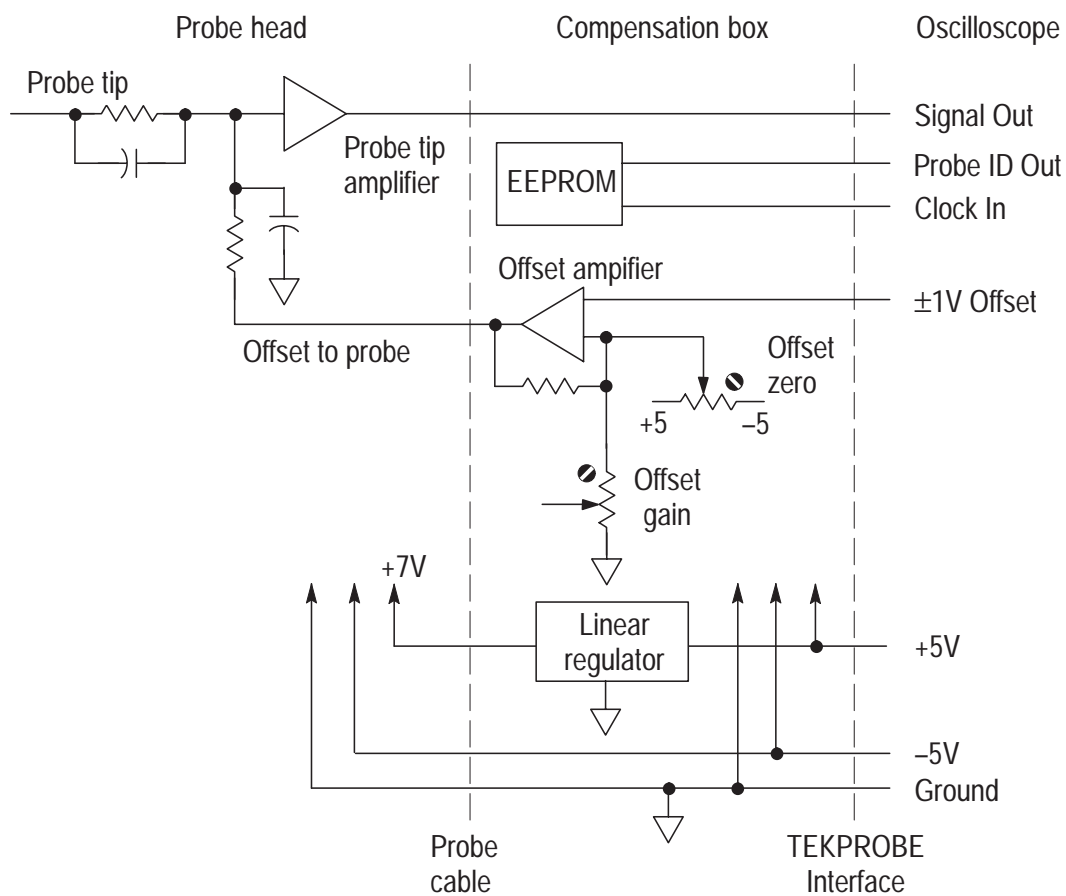

Figure 10: P6249 simplified schematic diagram

Probe Head and Cable Assembly

The probe head assembly contains an active amplifier circuit that buffers and amplifies the input signal. The amplifier receives power and an offset level from the compensation box assembly via the cable assembly.

All signal amplification and buffering is performed in the probe head assembly. No further amplification takes place in the compensation box.

Compensation Box

The compensation box contains the following circuits:

- Offset amplifier
- Probe identification EEPROM
- TEKPROBE interface
- V_{CC} , +7 V linear regulator

Offset Amplifier

The offset amplifier is used to offset the input signal DC component so that it stays at the optimal point of the probe linear dynamic range. For more information on the linear dynamic range characteristic, refer to *Input Linear Dynamic Range* on page 19.

The offset amplifier receives offset information as a ± 1 VDC voltage from the oscilloscope. The amplifier then amplifies it to match the probe characteristics and applies it to the probe head circuit.

The offset amplifier has two adjustments: offset zero and offset gain. These adjustments rarely need attention; however, detailed adjustment instructions are in the *Adjustment* section on page 49.

Probe Identification EEPROM

The probe identification EEPROM is used to configure the oscilloscope to the probe. The EEPROM receives a clock input from

the oscilloscope, and information about the probe is passed to the oscilloscope.

TEKPROBE Interface

The TEKPROBE interface provides a communication path between the probe and the oscilloscope. Contact pins provide power, signal, offset, and data transfer for the probe identification EEPROM.

V_{CC} , +7 V Regulator

The +15 V input is regulated to +7 V to supply the IC, V_{CC} .

Figure 11 shows the TEKPROBE interface pin functions. Refer to your oscilloscope service documentation for more detailed specifications.

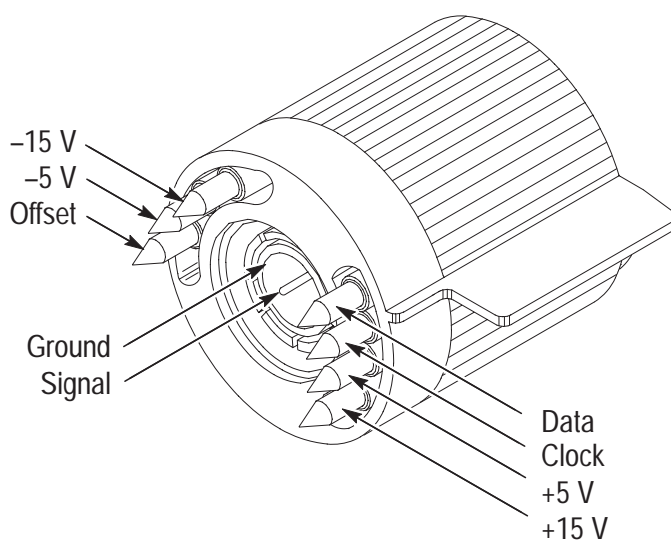

Figure 11: TEKPROBE interface

Performance Verification

Use the following procedures to verify the warranted specifications of the P6249 probe. Before beginning these procedures, refer to page 47 and photocopy the test record and use it to record the performance test results. The recommended calibration interval is one year.

These procedures test the following specifications:

- Output offset voltage
- DC attenuation accuracy
- Rise time

Equipment Required

Refer to Table 7 for a list of the equipment required to verify the performance of your probe.

Table 7: Equipment required for performance verification

Item Description	Performance Requirement	Recommended Example
Oscilloscope	TEKPROBE interface	Tektronix TDS 694C
Sampling Oscilloscope		Tektronix 11801
Sampling Head		Tektronix SD24
TEKPROBE Power Supply		Tektronix 1103
Calibration Step Generator		067-1338-0X
Adapter	Probe tip	015-0678-00
DC Power Supply	1 VDC at 1 mA	Tektronix PS280
DMM	0.5% accuracy at 2 VDC	Tektronix TX3
Feedthrough Termination	50 Ω \pm 0.05 Ω	011-0129-00

Table 7: Equipment required for performance verification (Cont.)

Item Description	Performance Requirement	Recommended Example
BNC-to-BNC coaxial cable	50 Ω coaxial cable	012-1342-00
Coaxial cable	Male-to-Male SMA, 20 in	174-1427-00
Precision coaxial cable	Male-to-Male SMA, 1 ns delay	015-0562-00
Adapter	SMA Female-to-Female	015-1012-00
Adapters (2)	SMA Female-to-BNC Male	015-0572-00
Adapter	BNC Female-to-Dual Banana	103-0090-00
Adapter	Y-lead adapter	196-3457-00
Adapters (2)	Klip Chip adapter	206-0364-00

Equipment Setup

Use this procedure to set up the equipment to test the probe.

1. Connect the probe to the oscilloscope.
2. Connect a Y-lead adapter with KlipChip adapters attached to the P6249.
3. Turn on the oscilloscope and enable the channel.
4. Allow 30 minutes for the equipment to warm up.

NOTE. *If your oscilloscope has a probe calibration routine, run it before making any of the following checks. However, certain firmware versions of TDS series oscilloscopes will return a Probe Cal Failed message. If this occurs, see Probe Calibration Errors on page 16 for more information.*

Output Zero

Use this procedure to verify the probe output zero.

1. Connect the test equipment as shown in Figure 12.
2. Attach the probe to a TEKPROBE interface on the 1103 power supply.
3. Ground the probe tip by connecting the probe tip to the probe ground socket. (Connecting two KlipChip adapters together is recommended.)
4. Set the 1103 offset **VAR/0V** to **0V**.
5. Observe the multimeter display and record the results on the test record.

The displayed DC level should be $0.00\text{ V} \pm 10\text{ mV}$.

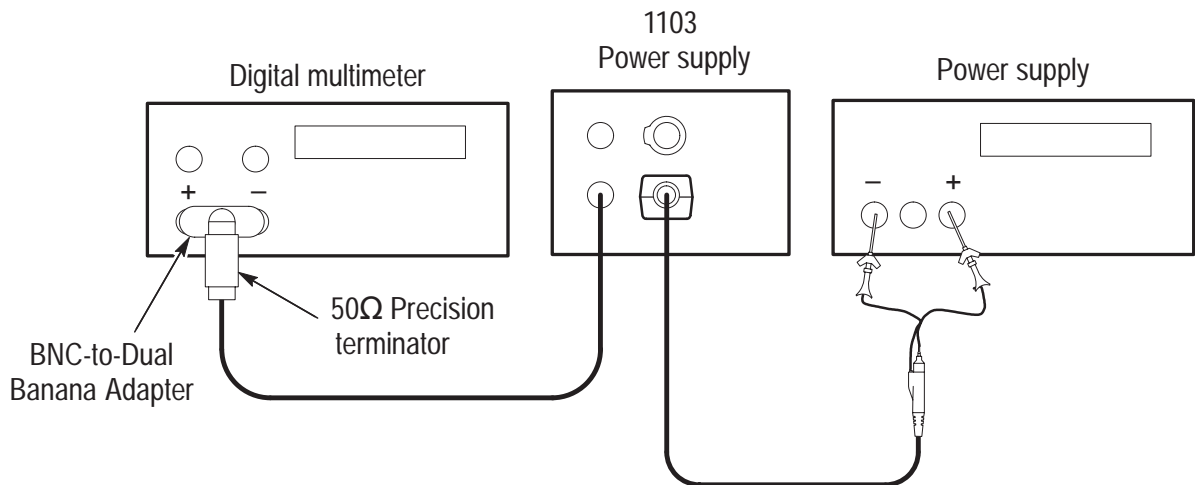

Figure 12: Setup for output zero and DC attenuation accuracy

DC Attenuation Accuracy

Use this procedure to verify the probe DC attenuation accuracy. Before beginning, read the procedure through completely.

1. Connect the test equipment as shown in Figure 12 on page 41.
2. Attach the probe to a TEKPROBE interface on the 1103 power supply.
3. Set the 1103 offset **VAR/0V** to **0V**.
4. Set the multimeter to read DC volts.
5. Connect the probe tip and ground to the power supply using the Y-lead and KlipChip adapters.
6. Allow 30 minutes for the equipment to warm up.

Record the results of steps 7 through 10 separately. Use the results to calculate the DC accuracy of the probe in step 11.

7. Set the power supply to +1.000 V. Record the power supply output as V_{max} .
8. Measure and record the multimeter reading as $M1$.
9. Set the power supply to -1.000 V. Record the power supply output as V_{min} .
10. Measure and record the multimeter reading as $M2$.

NOTE. *If you are unable to set the power supply precisely, record the actual readings and determine the absolute difference.*
 $|V_{max} - V_{min}| = \text{difference}$.

Divide the difference by 5 to account for the ideal probe attenuation factor. For example: 0.8 is the difference between +2 and -2, divided by 5.

11. Determine the percent error by using the formula below:

$$\%Error = \left[\frac{M1 - M2}{0.4} - 1 \right] \times 100\%$$

The calculated error should be $\leq 2\%$.

12. Record the results on the test record.

NOTE. *An unacceptable error value may result if a low tolerance termination is substituted for the recommended termination.*

Rise Time

This procedure verifies that the probe meets rise time specifications.

The probe rise time is calculated from rise times obtained by measuring the test system without the probe attached, and the test system plus the probe.

1. Connect the test equipment as shown in Figure 13.
2. Set the oscilloscope trigger to internal clock.
3. Turn on channel 1 on the SD-24, and then set the oscilloscope vertical scale to 50 mV/div.
4. Set the oscilloscope horizontal scale to 100 ps/div.
5. Adjust the oscilloscope horizontal and vertical position controls to display a signal similar to that shown in Figure 13.

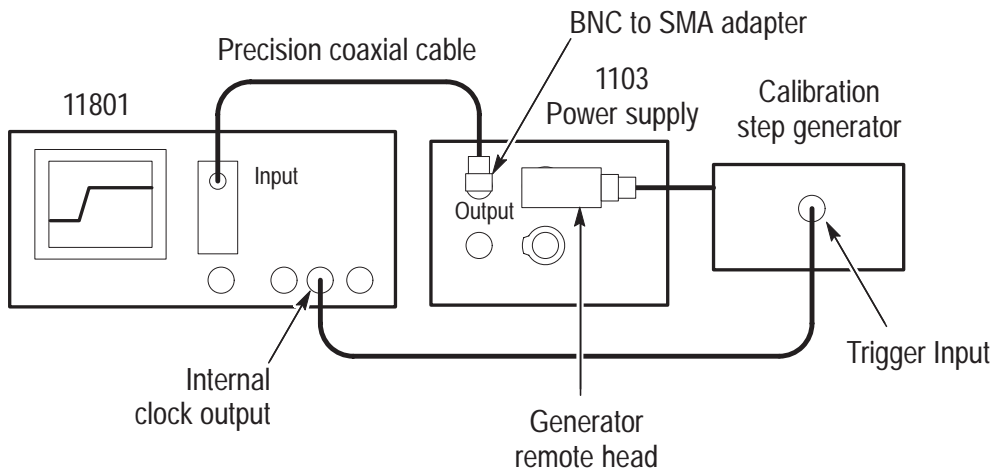

Figure 13: Test system rise time setup

6. Use the oscilloscope measurement capability to display rise time. Rise time is determined from the 10% and 90% amplitude points on the waveform. Record the rise time as t_s .

The system rise time (t_s) that you measured in step 6 represents the rise time of the test system without the probe.

The following steps instruct you to assemble the test setup that includes the probe, as shown in Figure 14. The system and probe rise time (t_{s+p}) that you measure in step 12 is used to calculate the probe rise time (t_p) in step 13.

7. Disconnect the calibration generator remote head from the 1103 power supply input. Remove the SMA-BNC adapter from the 1103 power supply input.
8. Use the BNC locking ring to connect the probe to the 1103 power supply channel 1 input. Disable the offset control on channel 1 of the 1103 power supply.
9. Connect the probe tip adapter to the calibration step generator remote head using the SMA female-female adapter. Insert the probe tip into the probe tip adapter.

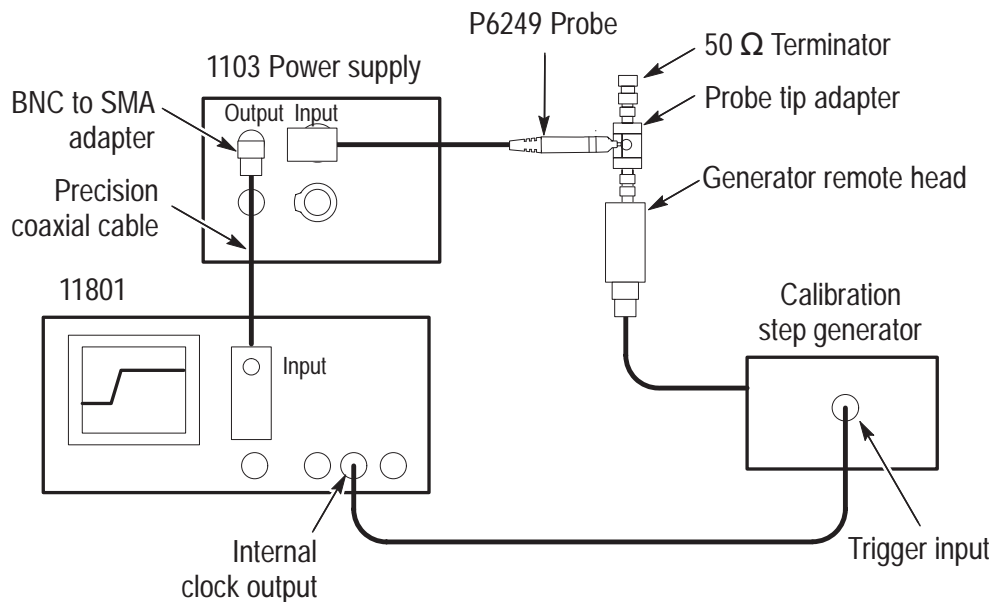

Figure 14: Test system and probe rise time setup

10. Press the **AUTOSET** button. Set the vertical to 10 mV/div and horizontal to 100 ps/div. Turn averaging on.
11. Adjust the oscilloscope horizontal and vertical position controls to display a signal similar to that shown in Figure 14.

NOTE. Do not touch the probe tip adapter when making calibration measurements. Measurement accuracy is degraded when the probe tip adapter is handled.

- 12.** Use the oscilloscope measurement capability to display rise time. Rise time is determined from the 10% and 90% amplitude points on the waveform. Record the rise time as t_{s+p} .
- 13.** Calculate the probe only rise time using the following formula:

$$t_p = \sqrt{t_{(s+p)}^2 - t_s^2}$$

- 14.** Check that the calculated rise time meets the probe specification. The rise time (t_p) must be ≤ 120 ps.
- 15.** Record the results on the test record.

Test record

Probe Model: _____

Serial Number: _____

Certificate Number: _____

Temperature: _____

RH %: _____

Date of Calibration: _____

Technician: _____

Performance test	Minimum	Incoming	Outgoing	Maximum
Output zero voltage (at probe output) ± 10 mV (20° C to 30° C)	- 10 mV	_____	_____	+ 10 mV
DC attenuation accuracy	N/A	_____	_____	≤2 %
Rise time	N/A	_____	_____	≤120 ps

Adjustments

The P6249 has two internal controls: offset zero and offset range. These controls rarely need to be adjusted, and only should be changed after a probe calibration and functional check has been performed on the oscilloscope.

In order to make adjustments to the probe, the compensation box top cover needs to be removed with the optional release tool. Refer to page 54. Use the optional adjustment tool for making any adjustments.

Adjustment Locations

Refer to Figure 15 for the location of the offset zero and offset range controls.

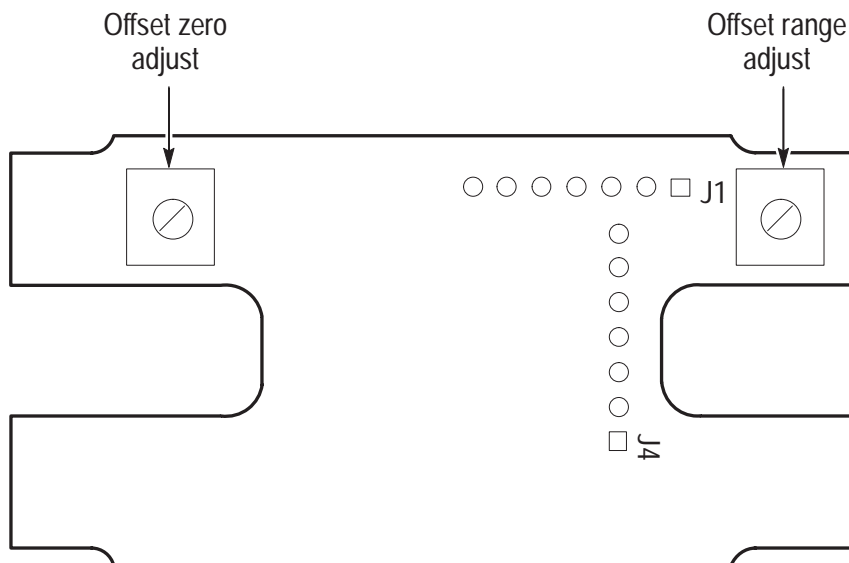

Figure 15: P6249 adjustment locations

Offset Zero

Use this procedure to adjust the probe offset zero.

***NOTE.** If your oscilloscope has a probe calibration routine, clear the probe calibration constants at this time.*

If the offset zero is adjusted, perform a functional check of the offset range before closing the compensation box.

1. Ground the probe tip by connecting the probe tip to the probe ground socket.
2. Set the channel vertical offset to 0.00 V.
3. Measure the displayed DC level.
4. Adjust **Offset Zero** for 0.00 ± 15 mV. (± 3 mV when measured directly without attenuation factor.)

Offset Range

Use this procedure to adjust the offset range of the probe. The offset zero of the probe should be checked before making any adjustment to the offset range. The offset range of the probe is approximately -3.5 to $+3.5$ volts.

1. Power on the 1103 power supply and turn on the offset.
2. Using a DMM, adjust the 1103 offset voltage to -0.5 V. Refer to Figure 16 for the location of the offset voltage test point.

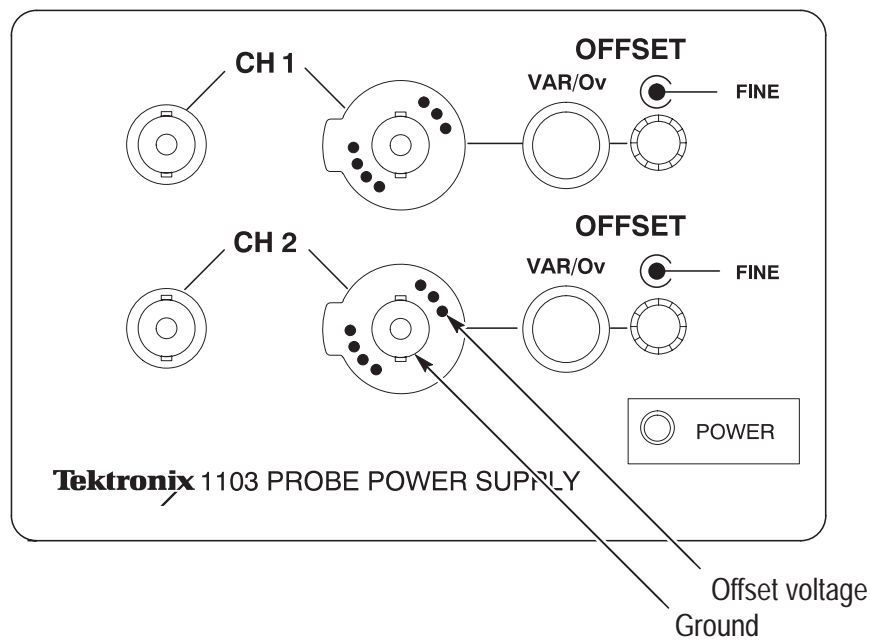

Figure 16: 1103 power supply offset voltage location

3. Connect the equipment as shown in Figure 17. Take care not to disturb the offset level setting on the 1103 power supply.

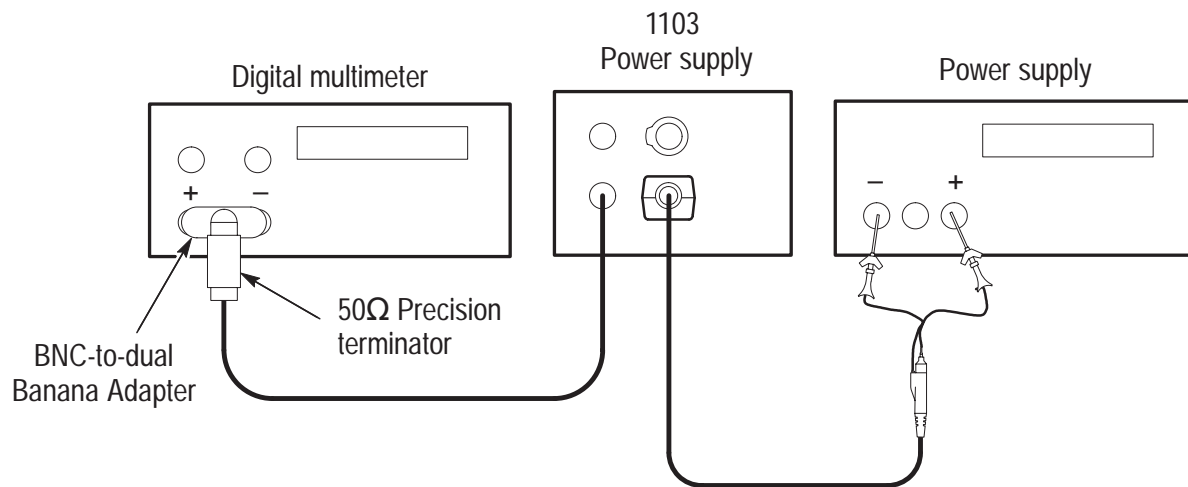

Figure 17: P6249 offset range setup

4. Set the DC power supply (using the DMM) to +2.5 VDC.
5. Observe the DC value on the DMM.
6. Adjust **Offset Range** for a DMM reading of $0\text{ V} \pm 5\text{ mV}$. Refer to Figure 15 on page 49 for the location of the offset range adjustment.

NOTE. After the offset zero and offset range have been adjusted, perform a probe calibration and functional check to verify performance.

Maintenance

This section describes the maintenance and repair procedures for the P6249.

Replacing TEKPROBE Interface Pins

TEKPROBE interface pins can stick and fail to make contact after time. Periodically check to see that each of the interface pins move freely and fully extends out of the interface. If any pin fails to move freely and fully extend, replace the pin.

To remove a TEKPROBE interface pin, firmly grasp the pointed tip with pliers and pull the pin out of the connector. See Figure 18.

No tools are required to install a replacement pin. Insert a new pin into the connector socket as far as possible using finger pressure. If necessary, seat the pin into the connector by pressing the tip gently but firmly against a hard surface, such as a wood block or table top.

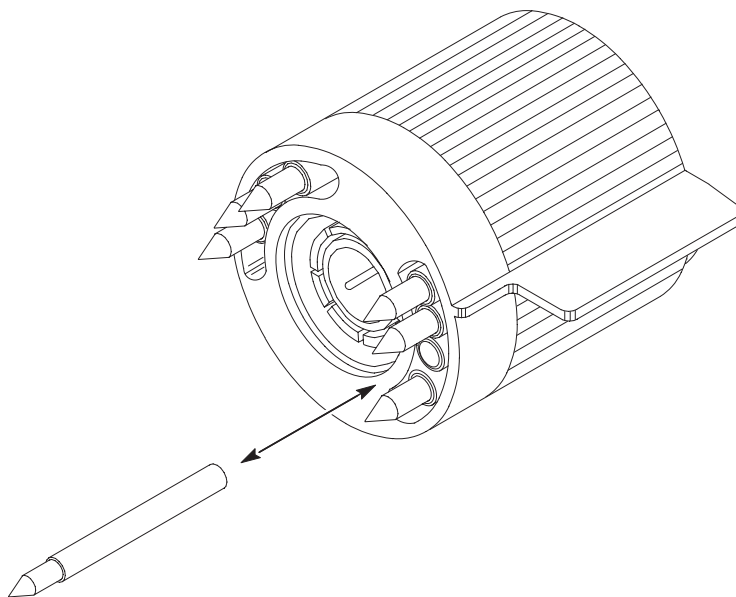

Figure 18: Replacing TEKPROBE interface pins

Removing and Replacing the Compensation Box Covers

Follow these steps to open the compensation box.

1. Press the optional release tool pins into the compensation box cover catches and gently lift the cover off a small distance. Refer to Figure 19.
2. Hold the open edge apart, and use the tool to open the other side of the compensation box.
3. With both sides of the box open, gently separate the two halves of the compensation box.

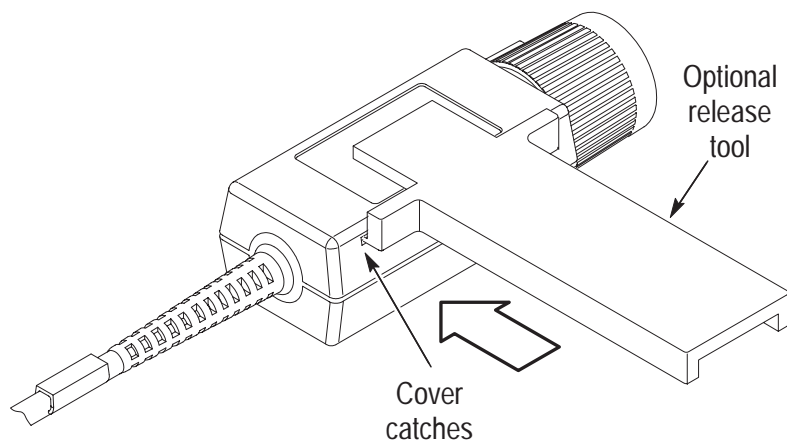

Figure 19: Removing the compensation box covers

To replace the covers, follow these steps:

1. Align the tabs with the notches on the cover halves. Refer to Figure 20.
2. Press the cover tabs in so that the cover can be lowered.
3. Slide the tabs into the notches.
4. Firmly press the pieces together until the cover catches snap into place.

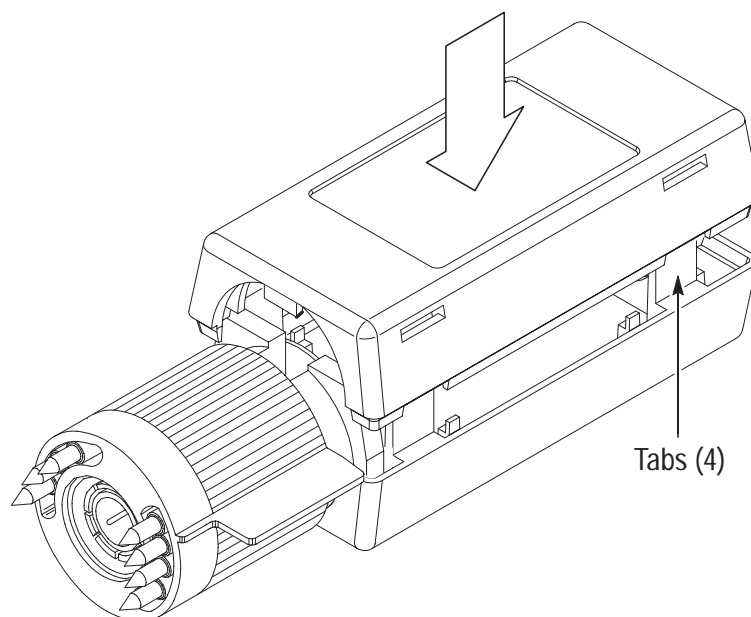

Figure 20: Replacing the compensation box cover

Removing and Replacing the TEKPROBE Interface Collar

To remove the TEKPROBE interface collar, firmly grasp the compensation box body with one hand, and the TEKPROBE interface collar with the other hand. Firmly pull the interface collar off.

To replace the interface collar, first note the pin configuration on the compensation box, and their holes in the interface collar. The group of three pins fit through the smaller of the two holes in the interface collar. See Figure 21.

Align the tab to the slot and gently press the two pieces together. See Figure 21.

Once installed, the TEKPROBE interface collar should rotate freely to lock and unlock.

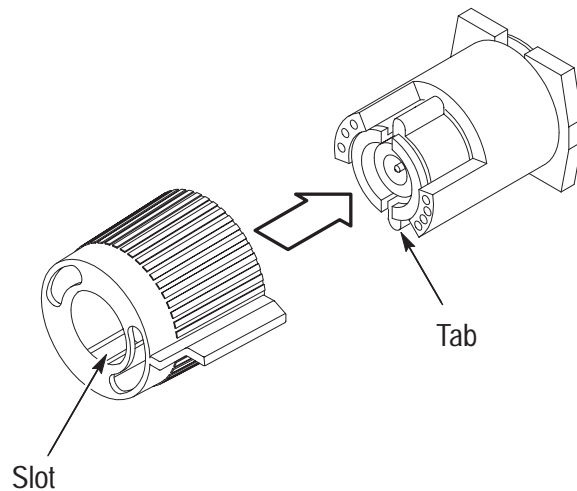

Figure 21: Replacing the TEKPROBE interface collar

Inspection and Cleaning

To prevent damage to probe materials, avoid using chemicals that contain benzene, toluene, xylene, acetone, or similar solvents.

Do not immerse the probe or use abrasive cleaners.

Dirt may be removed with a soft cloth dampened with a mild detergent and water solution, or isopropyl alcohol.

Replacement Parts

Refer to *Replaceable Parts* on page 63 for a list of customer replaceable parts. Due to the sophisticated design of the P6249, there are no user replaceable parts within the probe.

Preparation for Shipment

If the original packaging is unfit for use or not available, use the following packaging guidelines:

1. Use a corrugated cardboard shipping carton having inside dimensions at least one inch greater than the probe dimensions. The box should have a carton test strength of at least 200 pounds.
2. Put the probe into a plastic bag or wrap to protect it from dampness.
3. Place the probe into the box and stabilize it with light packing material.
4. Seal the carton with shipping tape.

Troubleshooting

This troubleshooting documentation details isolation to either the probe or the oscilloscope.

NOTE. *Certain firmware versions of TDS series oscilloscopes will return a “Probe Cal Failed” message when you run probe calibration routines on the P6249 probe. If this occurs, refer to Probe Calibration Errors on page 16.*

To troubleshoot the P6249, the probe must be attached to an operating TEKPROBE interface oscilloscope with the top cover of the compensation box removed. Refer to page 54 for instructions on opening the compensation box.

The oscilloscope should be set to the following settings:

- 50 Ω termination at instrument.
- DC coupling



CAUTION. *Observe caution when probing in the compensation box. Operating voltages will be present. Be careful not to touch or ground energized components.*

Work at a Level 1 ESD workstation when performing troubleshooting. The compensation box contains static sensitive devices.

Refer to Table 8 for troubleshooting procedures, and Figure 22 for troubleshooting test points.

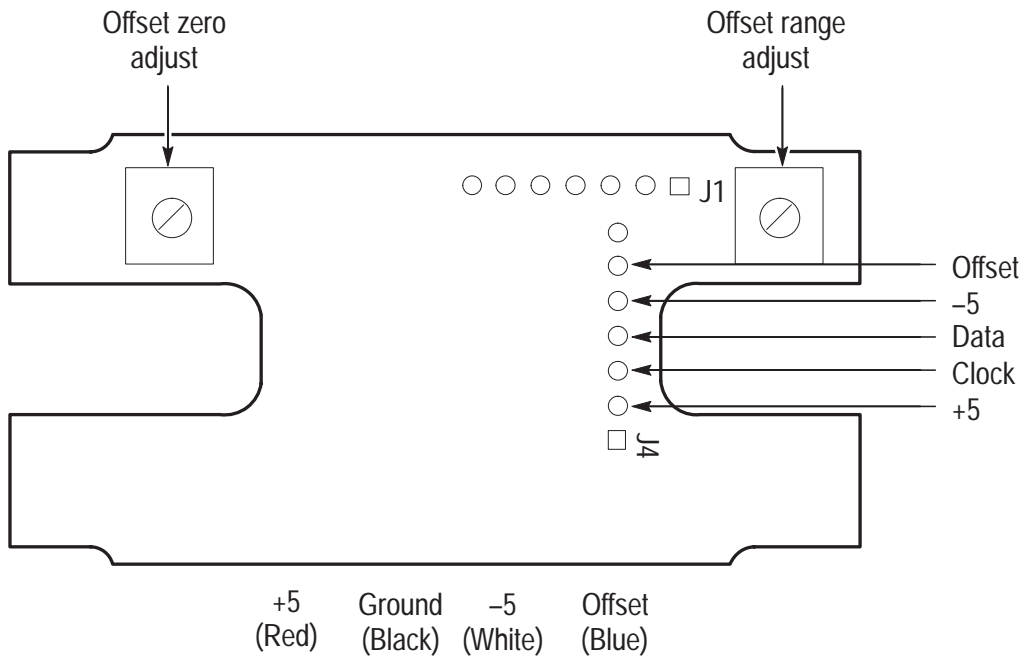

Figure 22: Compensation box test point locations

Table 8: Troubleshooting guide

Symptom	Checks	Result	Action
No Signal Out	Check known signal	No signal.	Continue checks
	Go to <i>Probe Power</i>	Probe power OK.	Replace probe.
Distorted or nonlinear signal	Is the instrument set to 50 Ω termination?	No	Set termination to 50 Ω, or install a feedthrough termination at the instrument input.
		Yes	Continue

Table 8: Troubleshooting guide (Cont.)

Symptom	Checks	Result	Action
Distorted or nonlinear signal	Is the signal within linear dynamic range? See page 19.	No	Set channel vertical offset to match signal characteristic.
No Offset Adjust (Signal present)	Go to <i>Probe Power</i> row Check variation of offset input from host instrument. See Figure 22. Signal should vary between +1 V and -1 V.	Probe power OK Offset input OK Offset input bad	Continue checks Replace probe. Check TEKPROBE interface pins on the compensation box. See page 53. Check TEKPROBE interface on host instrument. (Try an adjacent channel.) Repair host instrument
Probe Power	Check the power test points in the compensation box. See Figure 22.	Power OK Power bad	Continue checks. Check TEKPROBE interface pins on the compensation box. See page 53. Check TEKPROBE interface on host instrument. (Try an adjacent channel.) Repair host instrument



Replaceable Parts

This section contains a list of replaceable parts for the P6249. Use this list to identify and order replacement parts.

Parts Ordering Information

Replacement parts are available from or through your local Tektronix, Inc. service center or representative.

Changes to Tektronix instruments are sometimes made to accommodate improved components as they become available and to give you the benefit of the latest circuit improvements. Therefore, when ordering parts, it is important to include the following information in your order:

- Part number
- Instrument type or model number
- Instrument serial number
- Instrument modification number, if applicable

If a part you order has been replaced with a different or improved part, your local Tektronix service center or representative will contact you concerning any change in the part number.

Using the Replaceable Parts List

The tabular information in the Replaceable Parts List is arranged for quick retrieval. Understanding the structure and features of the list will help you find the information you need for ordering replacement parts.

Item Names

In the Replaceable Parts List, an Item Name is separated from the description by a colon (:). Because of space limitations, an Item Name may sometimes appear as incomplete. For further Item Name identification, U.S. Federal Cataloging Handbook H6-1 can be used where possible.

Indentation System

This parts list is indented to show the relationship between items. The following example is of the indentation system used in the Description column:

1	2	3	4	5	<i>Name & Description</i>
					<i>Assembly and/or Component</i>
					<i>Attaching parts for Assembly and/or Component</i>
					<i>(END ATTACHING PARTS)</i>
					<i>Detail Part of Assembly and/or Component</i>
					<i>Attaching parts for Detail Part</i>
					<i>(END ATTACHING PARTS)</i>
					<i>Parts of Detail Part</i>
					<i>Attaching parts for Parts of Detail Part</i>
					<i>(END ATTACHING PARTS)</i>

Attaching parts always appear at the same indentation as the item it mounts, while the detail parts are indented to the right. Indented items are part of, and included with, the next higher indentation. Attaching parts must be purchased separately, unless otherwise specified.

Abbreviations

Abbreviations conform to American National Standards Institute (ANSI) standard Y1.1

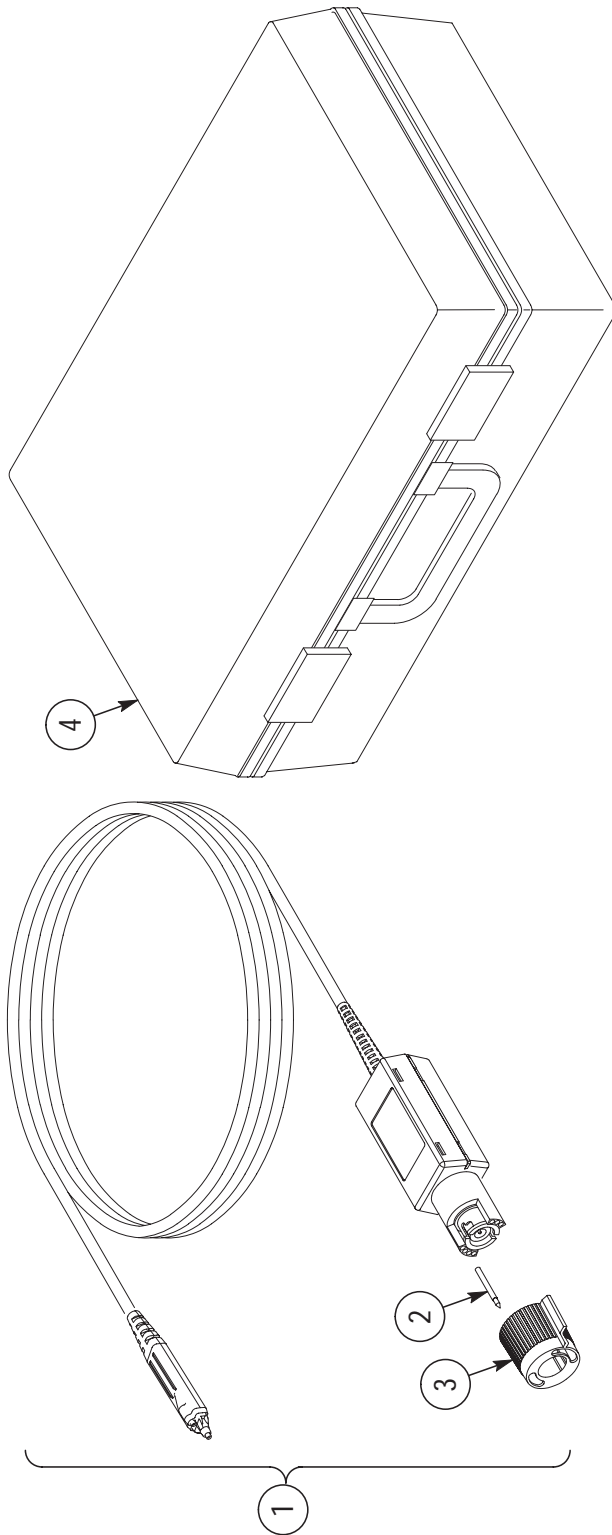

Figure 23: P6249 replaceable parts

Fig. & index no.	Tektronix part no.	Serial no. Effective	Discont	Qty	12345 name & description	Mfr. code	Mfr. part no.
23-1	010-0622-00			1	PROBE, FET ACT:>4 GHZ,5X,1PF,TDS SERIES	80009	010-0622-00
-2	131-3627-02			1	CONTACT,ELEC:GOLD PLATED TIP	80009	131-3627-02
-3	205-0191-00			1	SHELL,ELEC CONN:BNC,ABS,DOVE GRAY	80009	205-0191-00
-4	016-1879-00			1	CASE,STORAGE:PLASTIC,W/FOAM	80009	016-1879-00

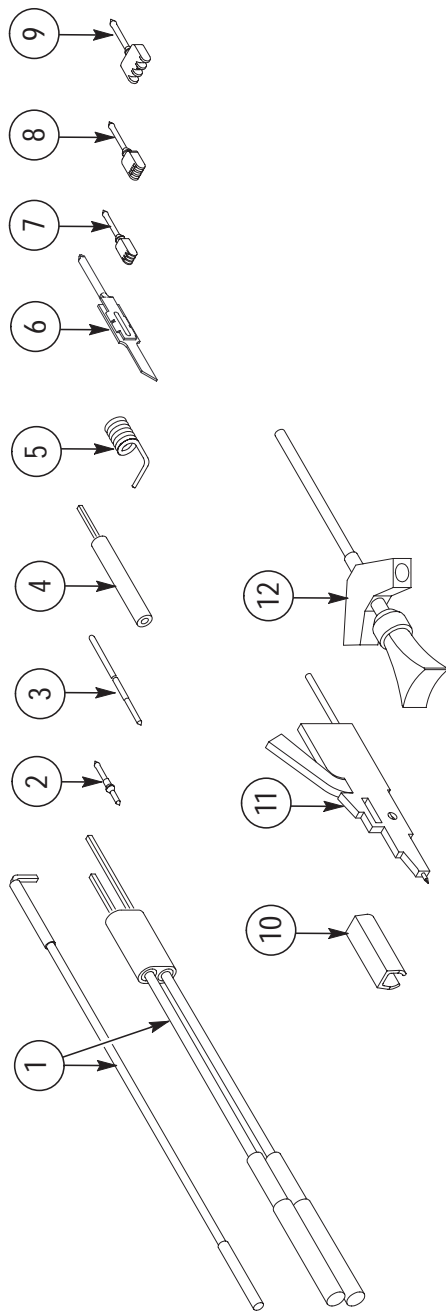

Figure 24: P6249 standard accessories

Fig. & index no.	Tektronix part no.	Serial no. Effective	Dscont	Qty	12345 name & description	Mfr. code	Mfr. part no.
STANDARD ACCESSORIES							
24-1	196-3456-00			1	LEAD SET:ACCESSORY KIT, INCL THREE 3.0 INCH GROUND LEAD, TWO DIFFERENTIAL LEAD	80009	196-3456-00
-2	131-5638-30			1	PROBE,TIP:PACKAGE OF 30	80009	131-5638-30
-3	016-1772-00			1	ACCESSORY KIT:POGO PIN,PKG OF 15	80009	016-1772-00
-4	016-1773-00			1	ACCESSORY KIT:GND PIN LENGTH ADAPTER,PKG OF 15	80009	016-1773-00
-5	016-1774-00			1	ACCESSORY KIT:ADAPTER SPRING,PKG OF 10	80009	016-1774-00
-6	ST501			1	PROBE,TIP,SURETOE:PACKAGE OF 12	80009	ST501
-7	SF503			1	ADPTR,SUREFOOT:0.5 MM EIAJ,PKG OF 12	80009	SF503
-8	SF502			1	ADPTR,SUREFOOT:25 MIL JEDEC,PKG OF 12	80009	SF502
-9	SF501			1	ADPTR,SUREFOOT:50 MIL JEDEC,PKG OF 12	80009	SF501
-10	016-1315-00			1	MARKER KIT,ID:CABLE MARKER BAND,2 EA, VAR COLRS	80009	016-1315-00
-11	013-0309-00			1	TIP,PROBE:MICROCKT TEST,PKG OF 2	80009	013-0309-00
-12	206-0364-00			2	TIP,PROBE:MICROCKT TEST,SMT KLIP CHIP	80009	206-0364-00
	071-0538-XX			1	MANUAL,TECH:INSTRUCTION,P6249	80009	071-0538-XX

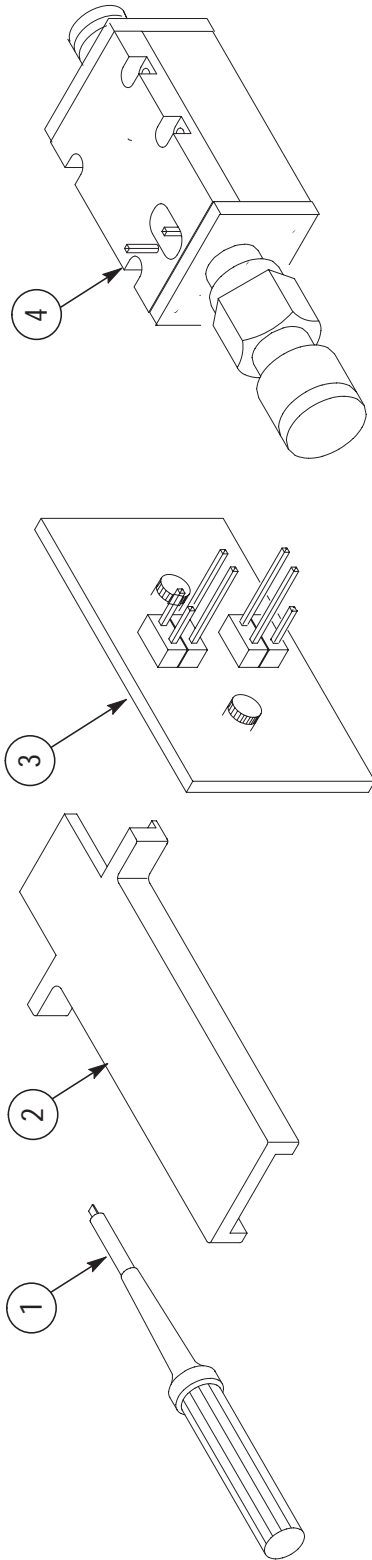

Figure 25: P6249 optional accessories

Fig. & index no.	Tektronix part no.	Serial no. Effective	Dscont	Qty	12345 name & description	Mfr. code	Mfr. part no.
25-1	003-1433-02			1	ADJUSTMENT TOOL	80009	003-1433-02
-2	003-1383-00			1	RLSE TOOL,COVER:COMP BOX, POLYCARBONATE	80009	003-1383-00
-3	679-4809-00			1	CKT BD SUBASSY:CALIBRATION	80009	679-4809-00
-4	015-0678-00			1	ADAPTER, PROBE:TIP,SMA 2 COMPACT SIZE,TERMINATED INTO 50 OHM TEST FIXTURE	80009	015-0678-00
	1103			1	TEKPROBE IF PS:W/OFFSET 2 CONN	80009	1103
	SMG50			1	MICROCKT TEST,SMT KLIP,PKG OF 20 (SEE 5-2-12)	80009	SMG50

OPTIONAL ACCESSORIES

CROSS INDEX – MFR. CODE NUMBER TO MANUFACTURER

Mfr. Code	Manufacturer	Address	City, State, Zip Code
80009	TEKTRONIX INC	14150 SW KARL BRAUN DR PO BOX 500	BEAVERTON OR 97077-0001

Free Manuals Download Website

<http://myh66.com>

<http://usermanuals.us>

<http://www.somanuals.com>

<http://www.4manuals.cc>

<http://www.manual-lib.com>

<http://www.404manual.com>

<http://www.luxmanual.com>

<http://aubethermostatmanual.com>

Golf course search by state

<http://golfingnear.com>

Email search by domain

<http://emailbydomain.com>

Auto manuals search

<http://auto.somanuals.com>

TV manuals search

<http://tv.somanuals.com>