



VC3ED FULL SIZE ELECTRIC CONVECTION OVEN

VC3ED ML-137013

- NOTICE -

This Manual is prepared for the use of trained Vulcan Service Technicians and should not be used by those not properly qualified.

This manual is not intended to be all encompassing. If you have not attended a Vulcan Service School for this product, you should read, in its entirety, the repair procedure you wish to perform to determine if you have the necessary tools, instruments and skills required to perform the procedure. Procedures for which you do not have the necessary tools, instruments and skills should be performed by a trained Vulcan Service Technician.

The reproduction, transfer, sale or other use of this Manual, without the express written consent of Vulcan, is prohibited.

This manual has been provided to you by ITW Food Equipment Group LLC ("ITW FEG") without charge and remains the property of ITW FEG, and by accepting this manual you agree that you will return it to ITW FEG promptly upon its request for such return at any time in the future.

TABLE OF CONTENTS

| | |
|--|----|
| GENERAL | 3 |
| INTRODUCTION | 3 |
| INSTALLATION | 3 |
| OPERATION | 3 |
| CLEANING | 3 |
| LUBRICATION | 3 |
| TOOLS | 3 |
| SPECIFICATIONS | 3 |
| REMOVAL AND REPLACEMENT PARTS | 5 |
| COVERS AND PANELS | 5 |
| CONTROL PANEL COMPONENTS | 7 |
| COMPONENT PANEL COMPONENTS | 7 |
| TEMPERATURE PROBE | 7 |
| HEATING ELEMENTS | 8 |
| BLOWER AND MOTOR | 9 |
| DOOR SWITCH | 10 |
| ROLLER LATCH ASSEMBLY (INDEPENDENT DOORS) | 11 |
| DOOR REMOVAL | 11 |
| HIGH LIMIT THERMOSTAT | 11 |
| INTERIOR LIGHTS | 12 |
| COOLING FAN | 12 |
| SERVICE PROCEDURES AND ADJUSTMENTS | 14 |
| SOLID STATE TEMPERATURE CONTROL TEST | 14 |
| TEMPERATURE PROBE TEST (SOLID STATE CONTROL) | 15 |
| SOLID STATE TEMPERATURE CONTROL CALIBRATION | 15 |
| HEATING ELEMENT TEST | 17 |
| BLOWER ADJUSTMENT | 17 |
| DOOR STRIKE ADJUSTMENT (INDEPENDENT DOORS) | 18 |
| ELECTRICAL OPERATION | 19 |
| COMPONENT FUNCTION | 19 |
| COMPONENT LOCATION | 20 |
| SEQUENCE OF OPERATION | 22 |
| SCHEMATICS AND WIRING DIAGRAMS | 24 |
| TROUBLESHOOTING | 30 |
| VC3ED | 30 |

GENERAL

INTRODUCTION

| FEATURES | | | | |
|---|--------------|---------------------|---------------|-------------|
| MODEL | CAVITY DEPTH | TEMPERATURE CONTROL | DOORS (50/50) | COOK TIMER |
| VC3ED | 26.5" | Solid State | Independent | 1-Hour Dial |
| NOTE: Stainless steel doors with window (standard) | | | | |

INSTALLATION

Refer to OPERATORS MANUAL for procedures related to Installation, Operation and Cleaning.

OPERATION

Refer to OPERATORS MANUAL for procedures related to Installation, Operation and Cleaning.

CLEANING

Refer to OPERATORS MANUAL for procedures related to Installation, Operation and Cleaning.

LUBRICATION

- Cavity blower motor has sealed bearings and requires no additional lubrication.

- HUSKEY™ TF-1000 grease or equivalent high temperature non-stick grease.

TOOLS

Standard

- Standard set of hand tools
- VOM with ability to measure micro amp current. VOM with minimum of NFPA-70E CAT III 600V, UL/CSA/TUV listed. Sensitivity of at least 20,000 ohms per volt. Meter leads must also be rated at CAT III 600V.
- Gear Puller to remove blower
- Temperature tester (thermocouple type)
- Manometer
- RTV sealant, 736 DOW silicone high temp (P/N 542133) or equivalent

SPECIFICATIONS

| AMPERAGE - 3 PHASE/ 60HZ | | | | | | | |
|--------------------------|---|-----------------------|------|------|---|------|------|
| MODEL | TOTAL POWER (KW) | PER LINE ¹ | | | RECOMMENDED CIRCUIT PROTECTION ² | | |
| | | 208V | 240V | 480V | 208V | 240V | 480V |
| VC3ED | 12.5 | 35 | 33 | 15 | 45 | 40 | 20 |
| NOTES: | ¹ Amperage values in the table are nominal. Tolerance is +5/-10%. | | | | | | |
| | ² Complied in accordance with National Electric Code, ANSI/NFPA 70, latest edition | | | | | | |

| AMPERAGE - 1 PHASE/ 60HZ | | | | | | | |
|--------------------------|--|-----------------------|------|------|---|------|------|
| MODEL | TOTAL POWER (KW) | PER LINE ¹ | | | RECOMMENDED CIRCUIT PROTECTION ² | | |
| | | 208V | 240V | 480V | 208V | 240V | 480V |
| VC3ED | 12.5 | 60 | 52 | 26 | 80 | 70 | 35 |
| NOTES: | ¹ Amperage values in the table are nominal. Tolerance is +5/-10%. ² Complied in accordance with National Electric Code, ANSI/NFPA 70, latest edition. | | | | | | |

SPECIFICATION SHEET

REMOVAL AND REPLACEMENT PARTS

COVERS AND PANELS



WARNING Disconnect the electrical power to the machine and follow lockout / tagout procedures.

Bottom Front Cover

1. The bottom front cover is secured with four (4) screws, two on each side of cover. Remove these screws then remove cover from oven.

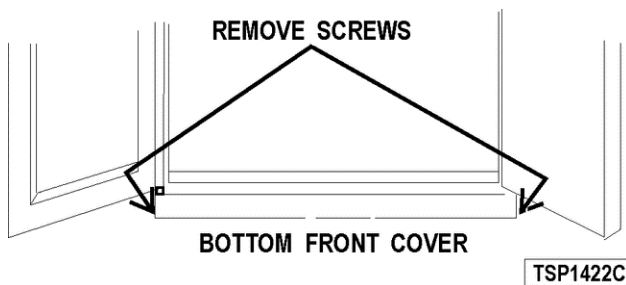

Fig. 1

2. Reverse procedure to install. Verify bottom cover is seated under front plate.

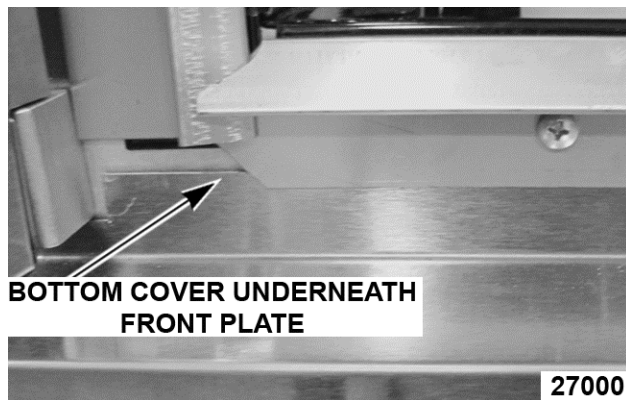

Fig. 2



WARNING Disconnect the electrical power to the machine and follow lockout / tagout procedures.

Control Panel

1. Remove three (3) screws on the right side which secure the control panel then left up and pull away.

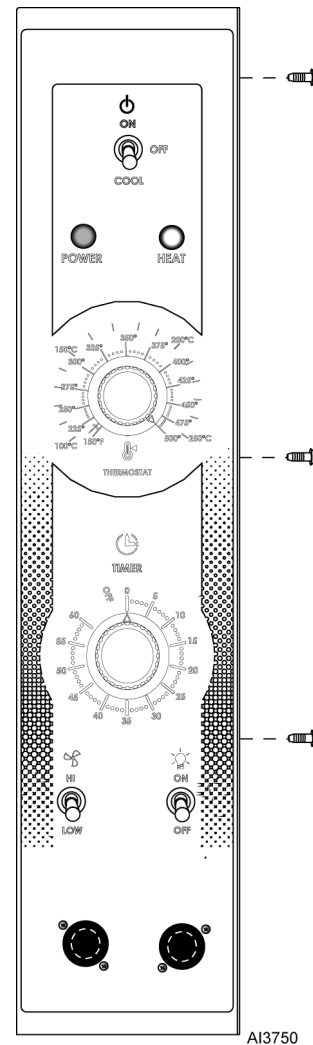

Control Panel Cover

2. Disconnect temperature probe leads from solid state temperature control.
3. Disconnect fuse wires.
4. Unplug wire harness connector to control panel components.
5. Reverse procedure to install.



WARNING Disconnect the electrical power to the machine and follow lockout / tagout procedures.

Right Side - Front Panel

1. Loosen two screws near front of oven, which secure bottom front cover.

- Loosen screws on left side of front panel and top cover screw.
- Remove screws along right side and bottom of front panel.

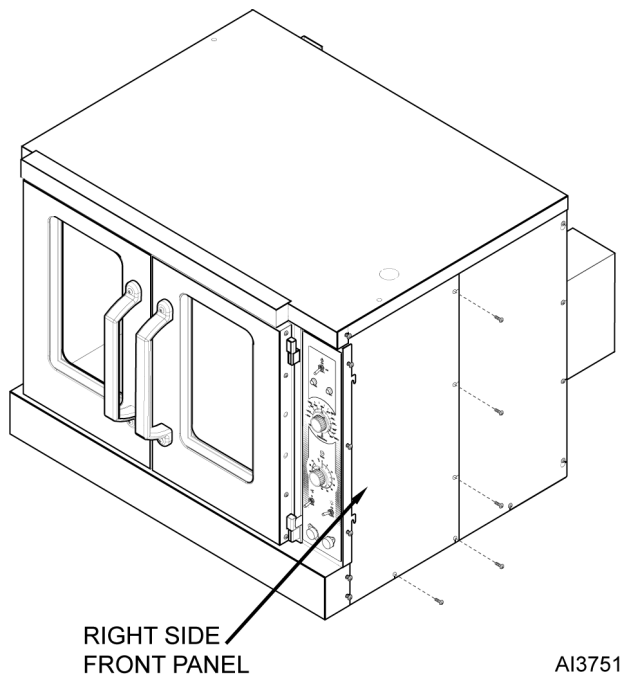

Fig. 4

- Slide right side front panel out.
- Reverse procedure to install.



WARNING Disconnect the electrical power to the machine and follow lockout / tagout procedures.

Right Side - Rear Panel

- Remove two middle screws along right side of rear panel.
- Remove screws along left side of rear panel.
- Remove bottom screws on rear panel.
- Loosen top and bottom screw along right side of rear panel.

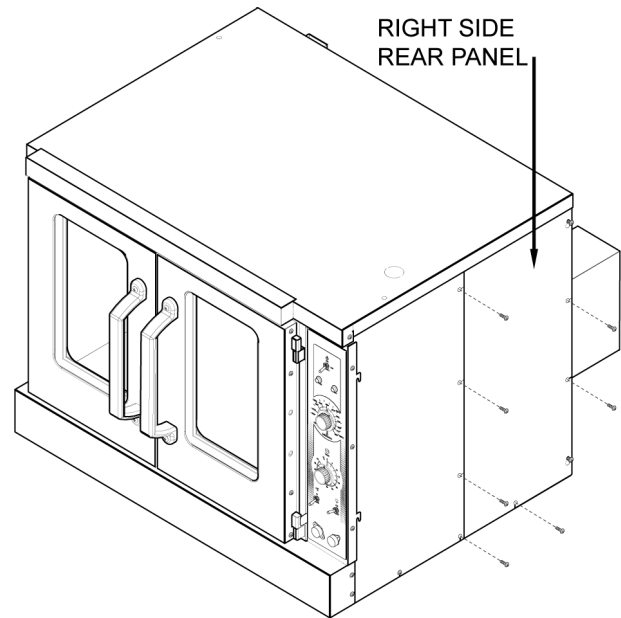

AI3752

Fig. 5

- Slide right side rear panel up and to the right to remove.
- Reverse procedure to install.



WARNING Disconnect the electrical power to the machine and follow lockout / tagout procedures.

Left Side Panel

- Remove screws along right side, middle left side, and bottom on left side panel.
- Loosen screws on top and bottom on left side of panel.
- Loosen two screws near front of oven, which secure bottom front cover.

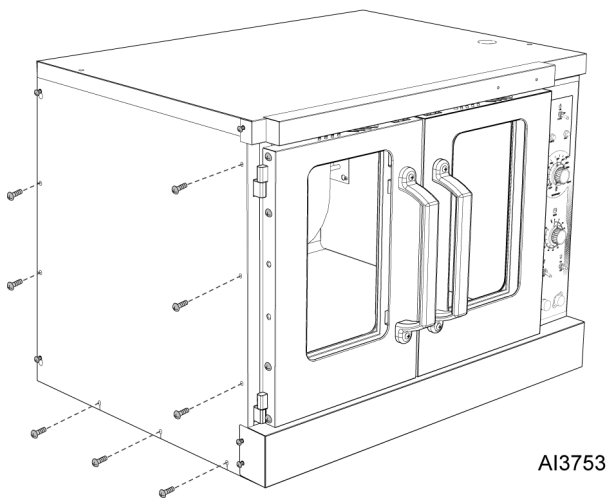

Fig. 6

4. Lift up and pull away to remove.
5. Reverse procedure to install.



⚠ WARNING Disconnect the electrical power to the machine and follow lockout / tagout procedures.

Fan Cover

1. Remove racks.
2. Lift fan cover up and out of oven.

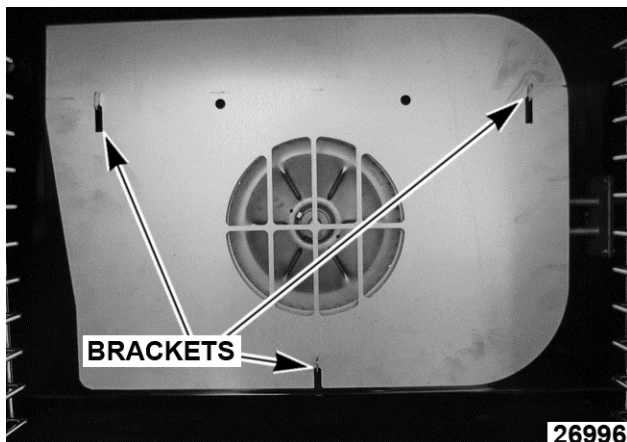

Fan Cover Removal

3. Reverse procedure to install.

CONTROL PANEL COMPONENTS



⚠ WARNING Disconnect the electrical power to the machine and follow lockout / tagout procedures.

Removable Components

1. Remove the CONTROL PANEL.
2. Remove the component being replaced.
3. Reverse the procedure to install the replacement component, then check oven for proper operation.

COMPONENT PANEL COMPONENTS



⚠ WARNING Disconnect the electrical power to the machine and follow lockout / tagout procedures.

Removable Components

1. Remove the RIGHT SIDE - FRONT PANEL.

NOTE: If right side panel is not accessible, this component can be serviced by removing the CONTROL PANEL.

2. Disconnect the wire leads to the component being replaced.
3. Remove the component.
4. Reverse the procedure to install the replacement component and check oven for proper operation.

TEMPERATURE PROBE



⚠ WARNING Disconnect the electrical power to the machine and follow lockout / tagout procedures.

1. Remove the RIGHT SIDE - FRONT PANEL.

NOTE: If right side - front panel is not accessible, this component can be serviced by removing the CONTROL PANEL.

Disconnect the probe leads from the solid state temperature control.

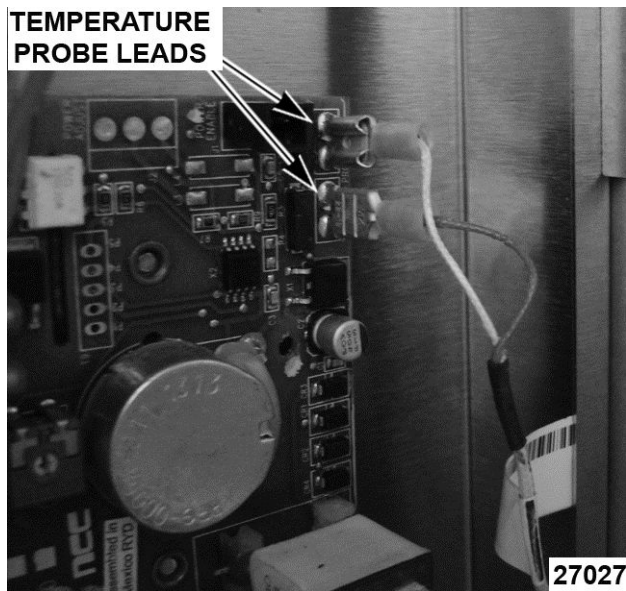

Fig. 8

2. Remove upper panel and pull out insulation cut-away.

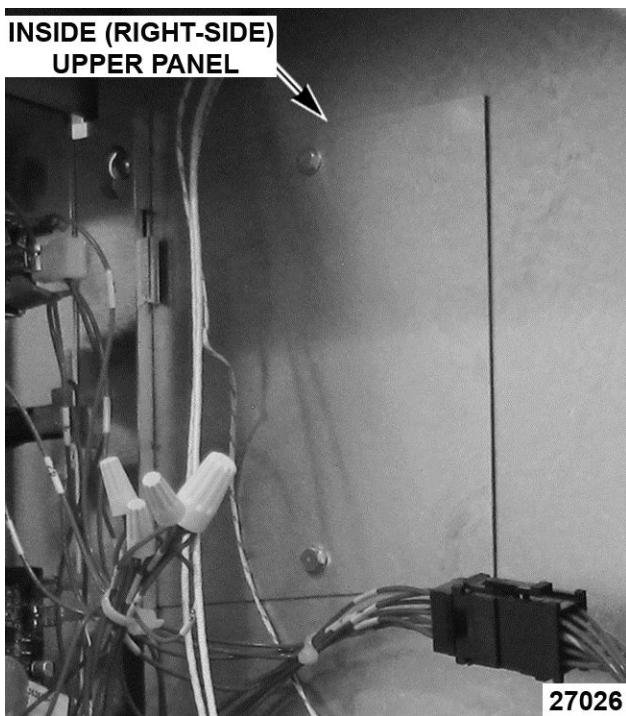

Fig. 9

3. Remove the racks from inside cavity.
4. Remove the probe guard.

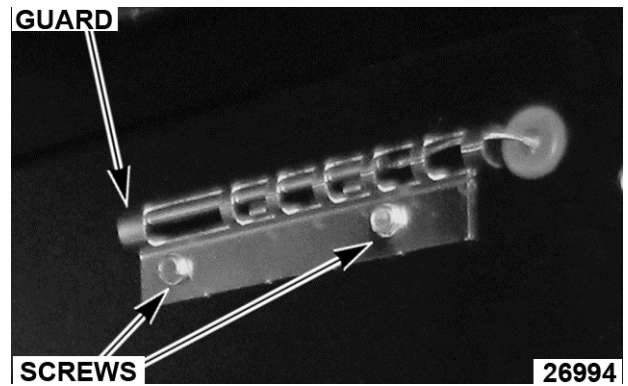

Fig. 10

5. Remove probe by pushing it through the oven wall and down through upper panel into the control panel area.

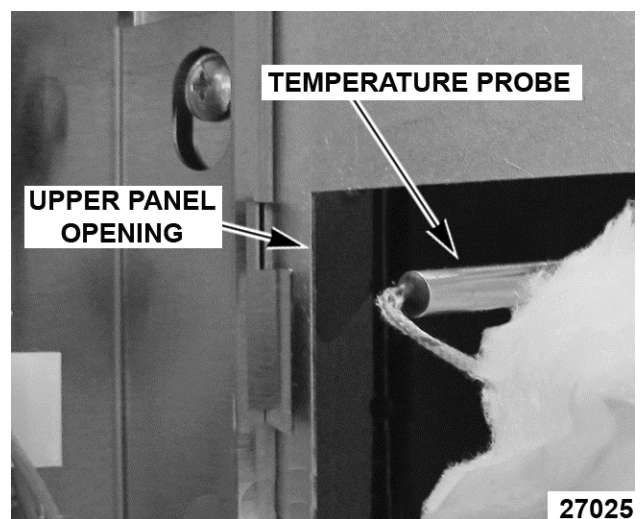

Fig. 11

6. Reverse the procedure to install the replacement probe.
7. Adjust the temperature control as outlined under SOLID STATE TEMPERATURE CONTROL CALIBRATION under Service Procedures and Adjustments.

HEATING ELEMENTS



WARNING Disconnect the electrical power to the machine and follow lockout / tagout procedures.

1. Remove RIGHT SIDE - REAR PANEL.
2. Disconnect element wire connectors.

ELEMENT CONNECTORS

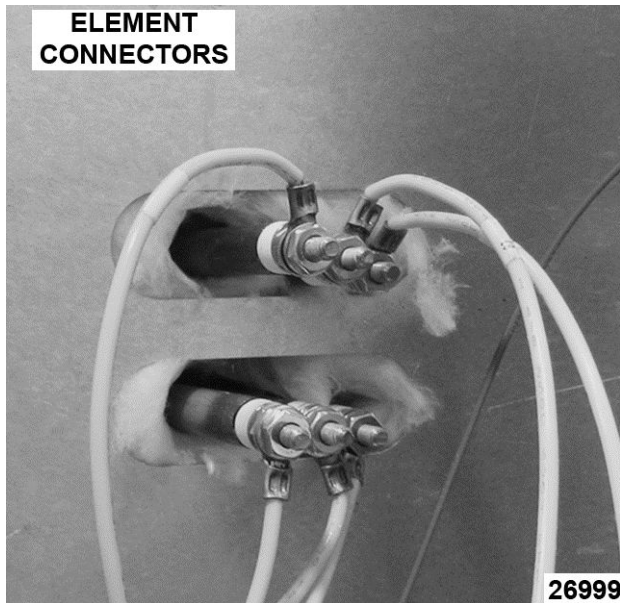
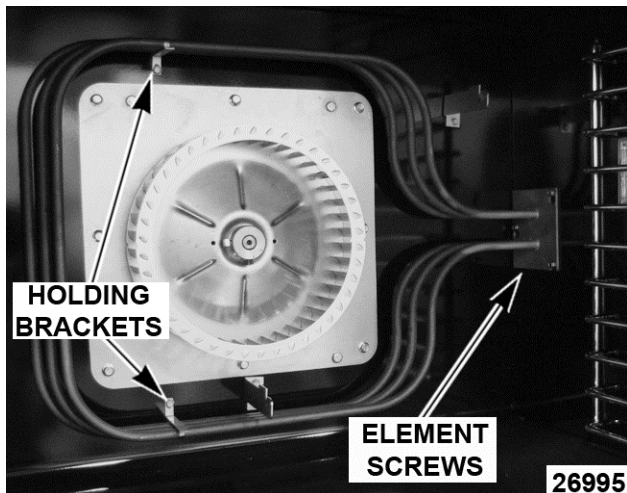

Fig. 12

3. Remove racks from cavity.
4. Remove FAN COVER.
Loosen element screws on side wall.
5. Remove screws on back wall holding brackets.
6. Pull elements forward, then away from right wall.



Heating Element

7. Reverse the procedure to install the replacement heating element.

BLOWER AND MOTOR



WARNING Disconnect the electrical power to the machine and follow lockout / tagout procedures.

1. Take out the racks and rack supports.
2. Lift off FAN COVER.
3. If replacing:
 - A. **Blower Only** - Loosen bolts on blower hub and using a bearing puller, remove blower from motor shaft.
 - 1) Reverse procedure to install and adjust blower position as outlined under BLOWER ADJUSTMENT under Service Procedures and Adjustments.
 - B. **Motor** - perform step 3A and continue procedure.
4. Remove bolts that secure the motor mounting plate to the rear wall.

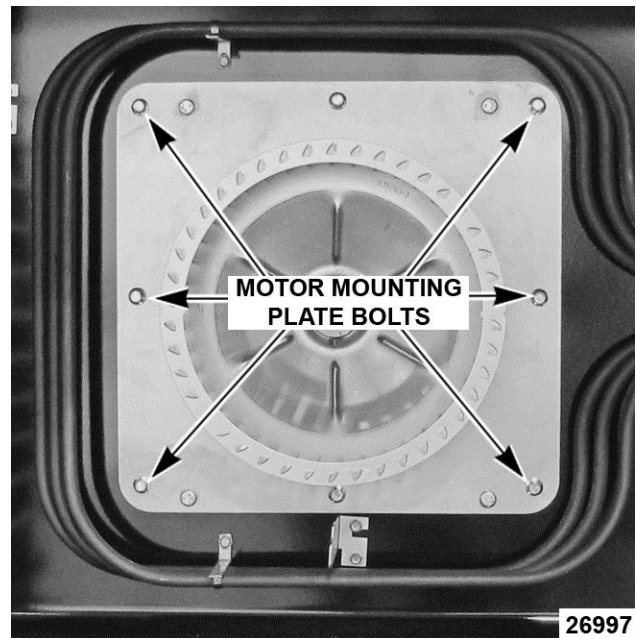

Fig. 14

5. Place a piece of cardboard on the bottom of the oven cavity to protect its surface from any damage during motor assembly removal.
6. Pull the motor assembly into the oven cavity and place it on the cardboard.
7. Remove the junction box cover from the motor, disconnect lead wires and remove the conduit.

8. Remove motor mounting bolts and flat washers then lift the motor from the mounting plate.
9. Position the replacement motor on the motor mounting plate and install mounting bolts and washers. Hand tighten mounting bolts only.

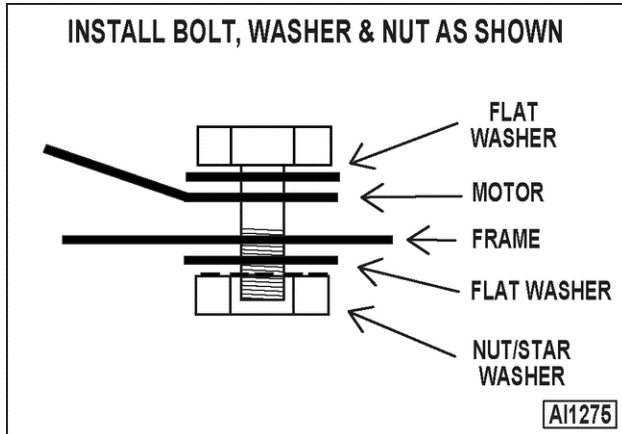

Fig. 15

10. Reconnect lead wires at the motor, replace conduit and junction box cover.

NOTE: Check data plate on motor for wiring schematic. The motor must rotate **clockwise** when viewed from the shaft end.

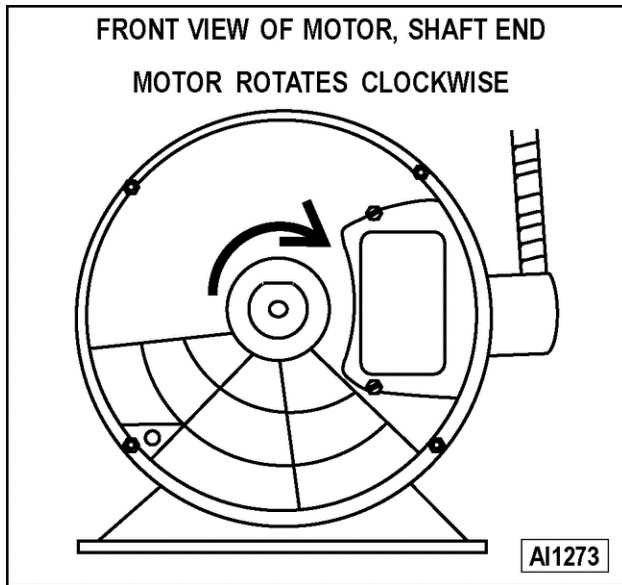

Fig. 16

11. Slide blower onto motor shaft until hub is flush with end of shaft then tighten bolts.
12. Adjust motor position until blower is parallel to motor mounting plate as outlined under BLOWER ADJUSTMENT under Service Procedures and Adjustments.
13. Position motor mounting plate on the rear wall and secure with screws and washers.

14. Replace the baffle panel.
15. Remove cardboard from the bottom of the oven cavity.
16. Check oven for proper operation then replace rack guides and racks.

DOOR SWITCH



WARNING Disconnect the electrical power to the machine and follow lockout / tagout procedures.

1. Remove the BOTTOM FRONT COVER.
2. Unscrew nut holding door switch.
3. Pull door switch and washer out through bottom panel opening.

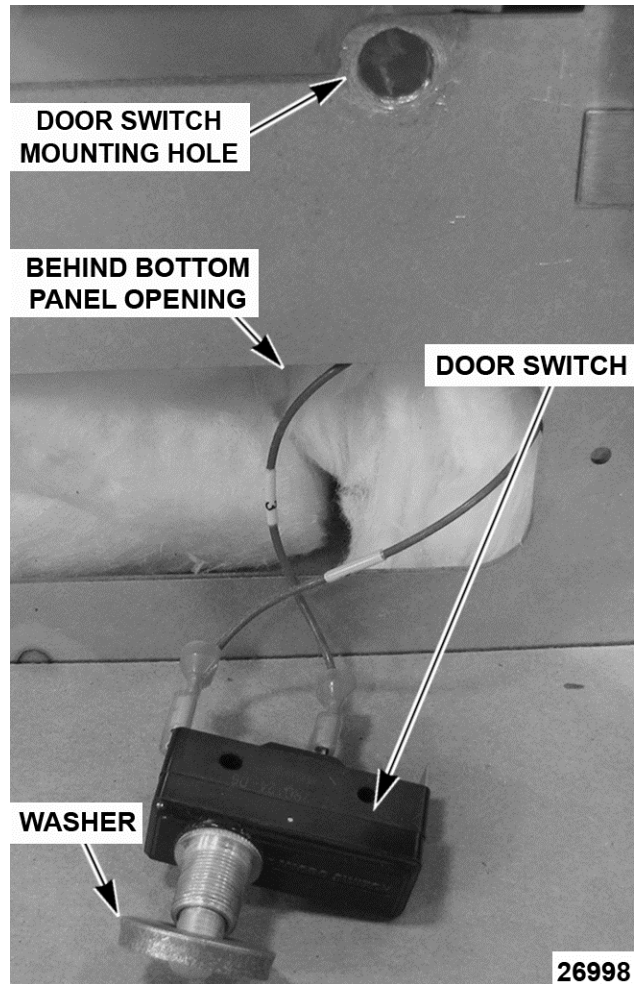

Fig. 17

4. Disconnect the lead wires to the door switch.
5. Reverse procedure to install the replacement switch.

ROLLER LATCH ASSEMBLY (INDEPENDENT DOORS)



WARNING Disconnect the electrical power to the machine and follow lockout / tagout procedures.

1. Remove the screws that attach roller latch assembly to door.

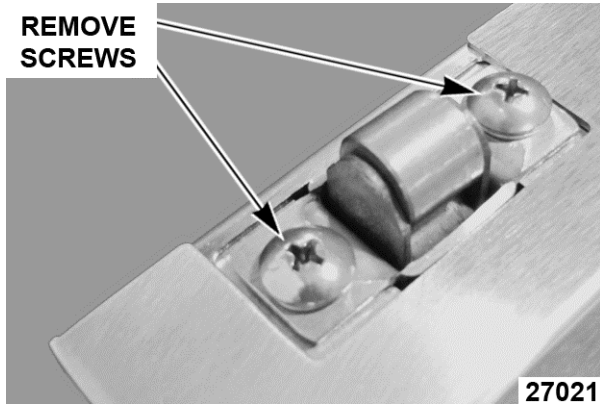

Fig. 18

2. Reverse procedure to install.

DOOR REMOVAL

1. Open door to a 90° angle.
2. Lift door up off hinges to remove.



Fig. 19

3. Reverse the procedure to install the replacement door and check oven for proper operation.

HIGH LIMIT THERMOSTAT



WARNING Disconnect the electrical power to the machine and follow lockout / tagout procedures.

1. Take out racks from the oven.
2. Remove the high limit thermostat cover/mounting plate from inside the oven cavity at the top.

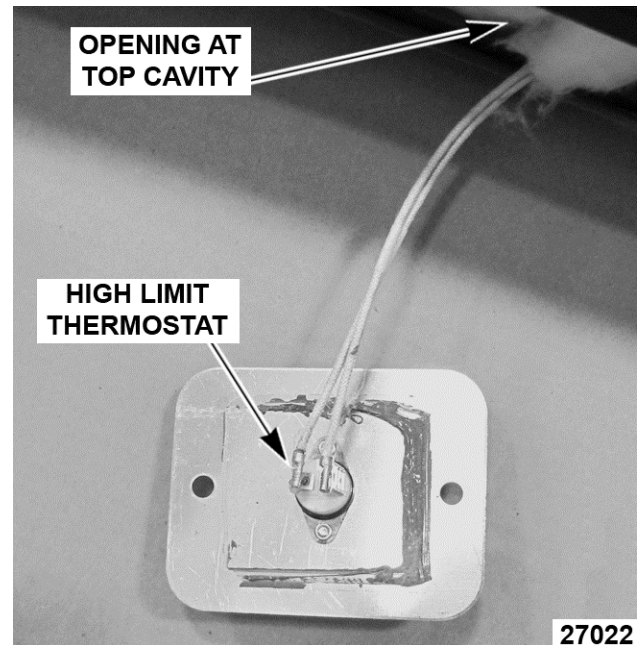

Fig. 20

3. Disconnect lead wires from high limit thermostat.

NOTE: Remove the old RTV sealer from the cover and mating surfaces inside the oven cavity and apply new high temperature RTV sealer before installing.

4. Reverse procedure to install.

INTERIOR LIGHTS



WARNING Disconnect the electrical power to the machine and follow lockout / tagout procedures.

NOTICE Do not touch the Halogen lamp with bare hands. If lamp is exposed to oil from the skin, the life will be reduced. Ensure lamp is free from oil and dirt before replacing.

Bulb Replacement

1. Pull lamp cover off.
2. Grasp lamp using a clean cloth and remove from lamp assembly.

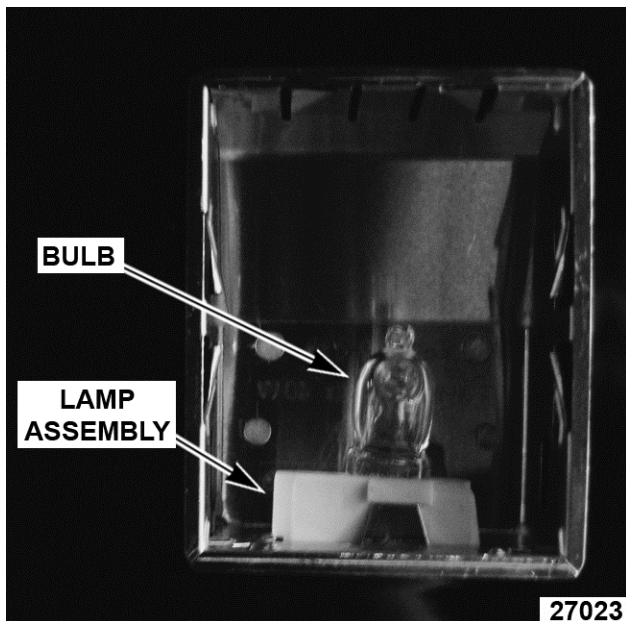

Fig. 21

3. Reverse procedure to install new bulb.

Lamp Assembly Replacement

1. Remove racks in cavity.
2. Pull lamp cover off.
3. Remove RIGHT SIDE - REAR PANEL.

Insert screw driver and push lamp assembly out into cavity.

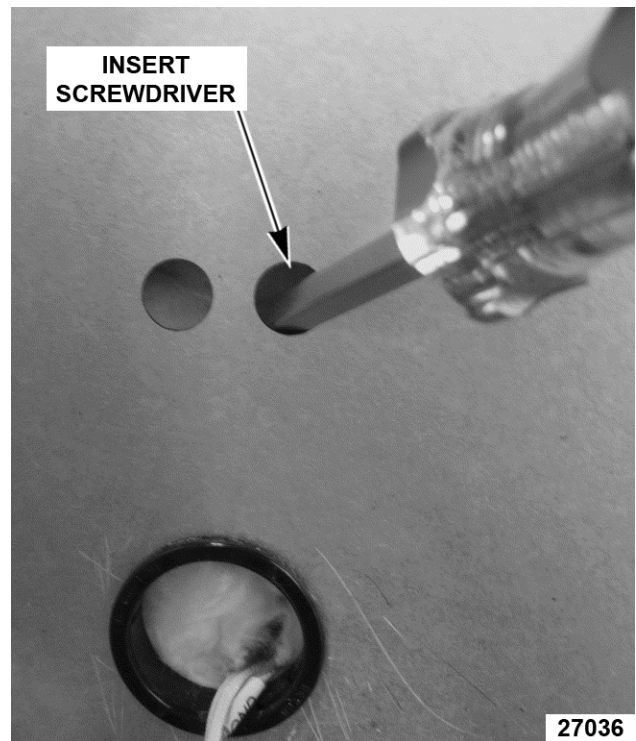

Fig. 22

4. Disconnect wires.
5. Reverse procedure to install new lamp assembly.

COOLING FAN



WARNING Disconnect the electrical power to the machine and follow lockout / tagout procedures.

1. Remove the RIGHT SIDE - FRONT PANEL.

NOTE: If right side - front panel is not accessible, this component can be serviced by removing the CONTROL PANEL.

2. Remove wire nuts from fan wire connections.

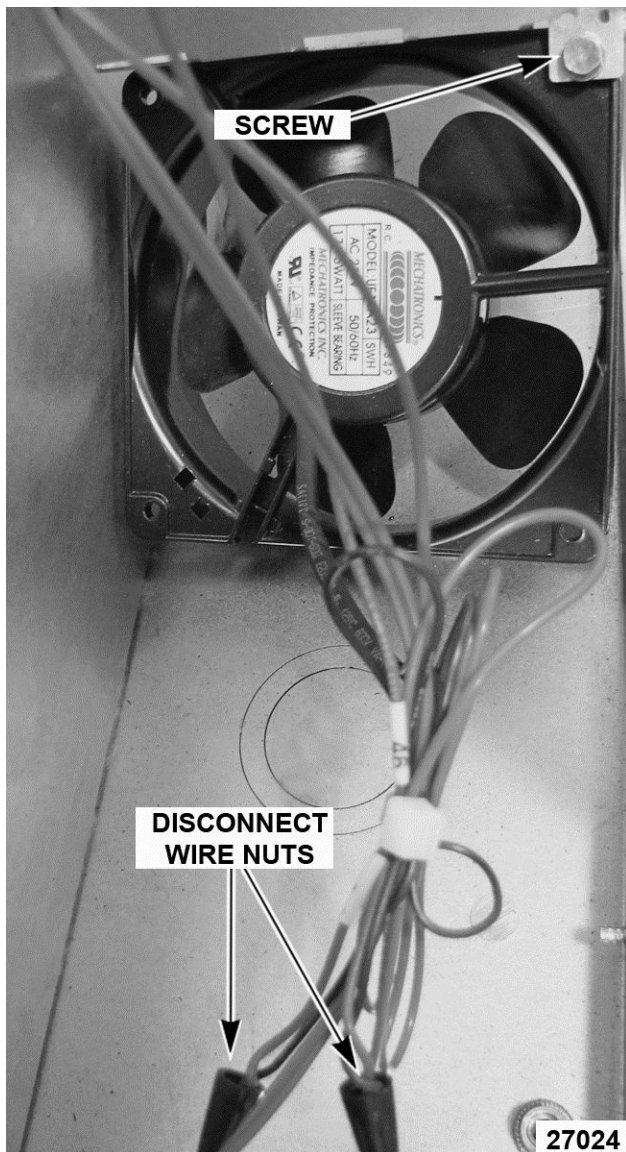

Fig. 23

3. Loosen the tab screw holding the fan to the component panel. Rotate the tab so that the fan will clear and remove the fan.
4. Reverse the procedure to install the replacement fan and check for proper operation.

NOTE: The fan must be installed so air is pulled from outside the rear of the oven and blown into the control area. The arrow on the fan body indicates "air flow" direction and should be pointing toward the controls.

SERVICE PROCEDURES AND ADJUSTMENTS

SOLID STATE TEMPERATURE CONTROL TEST



WARNING Certain procedures in this section require electrical test or measurements while power is applied to the machine. Exercise extreme caution at all times and follow Arc Flash procedures. If test points are not easily accessible, disconnect power and follow Lockout/Tagout procedures, attach test equipment and reapply power to test.

1. Remove the RIGHT SIDE - FRONT PANEL.

NOTE: If right side panel is not accessible, this component can be serviced by removing CONTROL PANEL.

2. Place a thermocouple in the geometric center of the oven cavity.

NOTE: Oven temperature must be below 450°F.

NOTE: If oven is equipped with "Cook and Hold" option, set to Cook (normal cooking) before continuing.

3. Set the temperature control to the maximum setting.
4. Check machine data plate for correct voltage to oven. Refer to diagram below for proper terminal locations and voltages before checking the control. Use the correct terminals for the corresponding voltage.
5. Turn the power switch to ON.

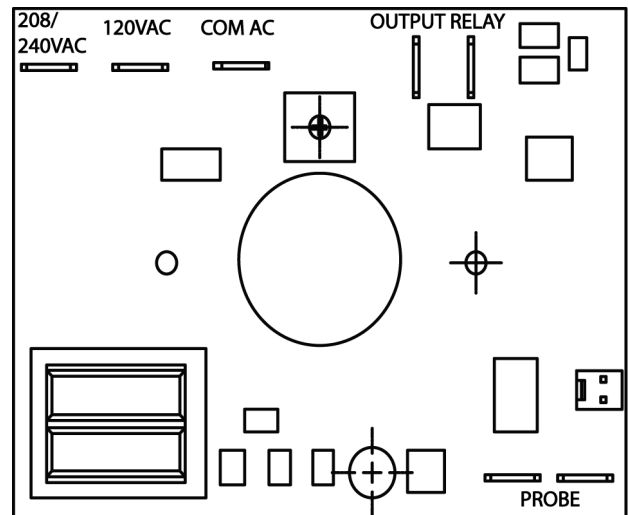

AI3754

Fig. 24

6. Check for proper voltage across terminals COM AC to 120VAC or COM AC to 208-240VAC for power to the control.
 - A. If correct, proceed to step 7.
 - B. If incorrect, problem is **not** with the temperature control. See TROUBLESHOOTING.
7. Check relay voltages on the board:
 - A. For 120VAC controls - check across OUTPUT RELAY terminal (left side) to 120 VAC terminal for input to the internal relay. Check across OUTPUT RELAY terminal (right side) to 120 VAC for output from the internal relay.
 - B. For 208-240VAC controls - check across OUTPUT RELAY terminal (left side) to 208-240 VAC terminal for input to the internal relay. Check across OUTPUT RELAY terminal (right side) to 208-240 VAC for output from the internal relay.
 - 1) If input voltage to the internal relay is correct, proceed to step 8. If input voltage to the internal relay is not present, problem is not with the temperature control. See TROUBLESHOOTING.

- 2) If output voltage from the internal relay is correct proceed to step 8. If output voltage from the internal relay is not correct, check temperature probe as outlined under TEMPERATURE PROBE TEST (SOLID STATE CONTROL).

8. Set the temperature control to the minimum setting.

NOTE: Oven temperature **must** be above 300°F.

9. Check for zero (0) volts AC across terminals OUTPUT RELAY terminal (right side) to 120 VAC or OUTPUT RELAY terminal (right side) to 208-240 VAC for no output from the internal relay.

- A. If correct, temperature control is functioning properly.
- B. If incorrect, check temperature probe as outlined under TEMPERATURE PROBE TEST (SOLID STATE CONTROL).

- 1) If temperature probe is OK:
 - a. Turn the power switch OFF.

WARNING Disconnect the electrical power to the machine and follow lockout / tagout procedures.

- b. Replace the temperature control and check calibration as outlined under SOLID STATE TEMPERATURE CONTROL CALIBRATION.



TEMPERATURE PROBE TEST (SOLID STATE CONTROL)



WARNING Disconnect the electrical power to the machine and follow lockout / tagout procedures.

NOTE: The temperature probe used in conjunction with the Solid State Temperature control is an RTD (resistance temperature detector) of the Thermistor type. As temperature increases the resistance value decreases.

1. Remove the RIGHT SIDE - FRONT PANEL.

NOTE: If right side panel is not accessible, this component can be serviced by removing CONTROL PANEL.

2. Place a shielded thermocouple in the geometric center of the oven cavity and determine the temperature in the oven cavity.
3. Remove the probe lead wires from the solid state temperature control.
4. Test the probe with an multimeter.
 - A. If the measured resistance values are inside the given tolerance then the probe is functioning properly.
 - B. If the measured resistance values are outside the given tolerance then replace the probe and retest.
 - 1) Check oven for proper operation.
5. Reverse procedure to install.

| TEMP (°F) | OHMS * | TEMP (°F) | OHMS * |
|-----------|--------|-----------|--------|
| 77 | 90,000 | 360 | 822 |
| 240 | 4,077 | 380 | 656 |
| 260 | 3,016 | 400 | 529 |
| 280 | 2,266 | 425 | 424 |
| 300 | 1,726 | 450 | 334 |
| 320 | 1,332 | 475 | 266 |
| 340 | 1,041 | | |

* Resistance in ohms ± 10%

SOLID STATE TEMPERATURE CONTROL CALIBRATION

Calibration Steps

1. Place a thermocouple in the geometric center of the oven cavity.
2. Set the ON / OFF / OVEN COOL switch to ON.
3. Set the temperature controller dial to 350°F.
4. Allow the oven temperature to stabilize (minimum three heating cycles).
5. Record the temperature at which the Heat lamp comes ON (heating starts) and goes OFF (heating stops). This is the control differential. Heat lamp OFF temp - Heat lamp ON temp = Control Differential.
6. The nominal control differential should be less than 20°F.

- A. If the control differential is less than 20°F, the temperature control circuit is functioning properly. Proceed to step 7.
 - B. If the control differential is more than 20°F, check the temperature probe as outlined under Temperature Probe Test.
 - C. If the control differential is more than 20°F and the probe passes the test parameters, then temperature controller is malfunctioning. Install a new temperature controller and run calibration steps again.
7. Calculate the average oven temperature by adding the actual minimum temperature to the actual maximum temperature and dividing by 2.

EXAMPLE:

Oven set to 350°F.

Actual minimum oven temperature = 335°F

Control turns on at 334°F

Actual maximum oven temperature = 347°F

Control turns off at 340°F

$$335 + 347 = 682$$

$$682 / 2 = 341 \text{ (the control is } 9^\circ\text{F out of calibration)}$$

$$340 - 334 = 6^\circ\text{F Control Differential}$$

$$347 - 335 = 12^\circ\text{F Oven Temperature Differential.}$$

- A. If the average oven temperature is within +/- 5°F from the dial setting, no calibration is necessary.
 - B. If the average oven temperature is not within +/- 5°F, calibration is recommended.
8. Loosen the set screw on the temperature controller and carefully remove the knob from the shaft, without rotating the shaft. This will expose the calibration adjustment control access hole in the front panel.

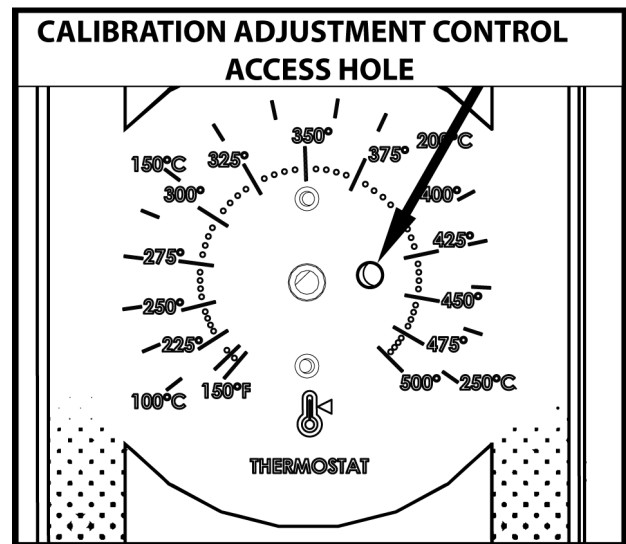

AI3777

Fig. 25

- 9. Monitor the internal oven temperature and determine at what temperature the control should turn on to give you the required minimum temperature (Example: $350 - 341 = 9$; $334 + 9 = 341$. 341°F is the temperature at which you would wish the controller to turn on).
- 10. After allowing the oven to operate through several cycles (minimum 3 cycles), monitor the temperature as it falls to the desired turn on point. Using a small screw driver, adjust the calibration adjustment until the controller turns on at the desired turn on temperature.
- 11. The calibration control is adjusted clockwise in order to increase the set temperature and counter clockwise to decrease the set temperature.
- 12. The controller has only +/- 25°F of adjustment. 1/4 turn of the calibration adjustment represents approximately 20°F shift in calibration.

HEATING ELEMENT TEST



⚠ WARNING Certain procedures in this section require electrical test or measurements while power is applied to the machine. Exercise extreme caution at all times and follow Arc Flash procedures. If test points are not easily accessible, disconnect power and follow Lockout/Tagout procedures, attach test equipment and reapply power to test.

1. Turn the power switch ON and set the oven temperature control to the highest setting.
2. Measure the voltage at the heating element terminals and verify it against the data plate voltage.
 - A. If voltage is incorrect, find the source of the problem.
 - B. If voltage is correct, check current draw (amps) through the heating element lead wires.

NOTE: This method is preferred over a resistance check when a clamp on type amp meter is available.

- 1) If current draw is correct then heating element is functioning properly. See Heating Element Values table.
- 2) If current draw is not correct, turn the power switch OFF and disconnect the electrical supply to the oven.
 - a. Replace heating element, then proceed to step 3.
- C. If unable to check current draw, a resistance check may indicate a malfunctioning element.
 - 1) Turn the power switch OFF and disconnect the electrical supply to the oven.
 - 2) Remove the lead wires from the heating element and check resistance (ohms). See Heating Elements Values table.
3. Check for proper operation.

| HEATING ELEMENT VALUES | | | | |
|------------------------|---|------------------|------|------------------|
| VOLT. | KW PER ELEMENT | AMPS PER ELEMENT | | OHMS PER ELEMENT |
| | | 1 PH | 3 PH | |
| 208 | 4 | 19 | 19 | 10 |
| 240 | 4 | 16.5 | 16.5 | 14.5 |
| 480 | 4 | 8 | 8 | 57 |
| NOTES: | 1. Values in the table are nominal. Tolerance is +5/-10%. 2. Voltage values are @ 60HZ. 3. Resistance values (ohms) are @ room temperature. | | | |

BLOWER ADJUSTMENT



⚠ WARNING Disconnect the electrical power to the machine and follow lockout / tagout procedures.

1. Remove the blower motor and mounting assembly by following steps 1 through 7 as outlined under BLOWER AND MOTOR under Removal and Replacement of Parts.
2. Loosen the motor mounting bolts.
3. Adjust the motor position until the blower is parallel to and 1/4 inch away from the motor mounting plate. Check for squareness of the blower to the motor mounting plate at the top, bottom, left and right of the blower.
 - A. If the blower is square then tighten motor mounting bolts and proceed to step 4.
 - B. If the blower is not square continue adjusting until proper spacing is achieved then tighten motor mounting bolts.

NOTE: If necessary, place shims between motor and frame.

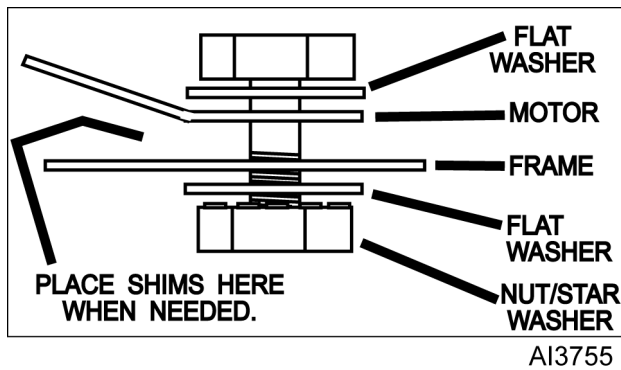

Fig. 26

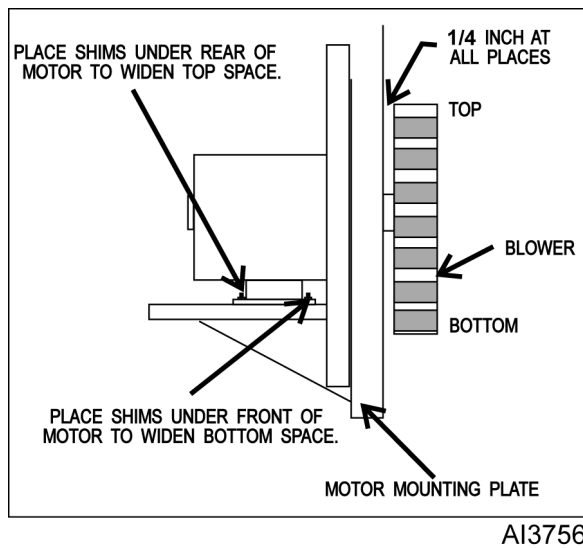

Fig. 27

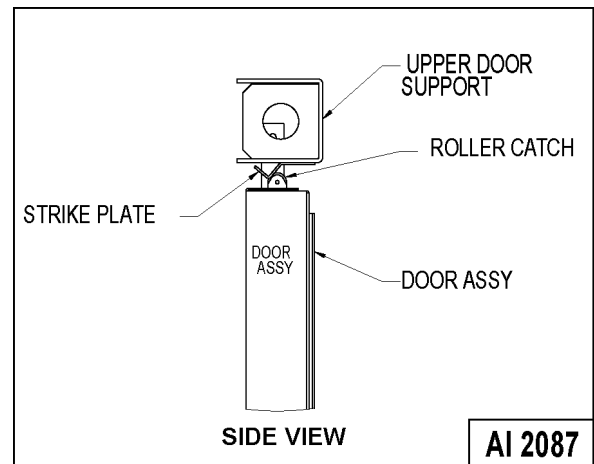

Fig. 28

2. Open and close the doors several times while observing the roller latch and strike plate operation.
 - A. Replace roller latch if malfunctioning as outlined under ROLLER LATCH ASSEMBLY (INDEPENDENT DOORS) and adjust as outlined in this procedure.
3. Each oven door should open with a force of 8 to 25 pounds when pulled at the handle. The adjustments must allow the doors to remain closed during normal operation and allow opening without exertion by the user.

4. Reverse the procedure to install.

DOOR STRIKE ADJUSTMENT (INDEPENDENT DOORS)

1. Open the doors and inspect door strike for proper shape.
 - A. Bend strike plate.

ELECTRICAL OPERATION

COMPONENT FUNCTION

| | |
|--|---|
| Power Switch (S1) | Determines the mode of operation; ON, OFF, or COOL down. |
| Oven Light Switch (S3) | Controls the oven cavity lights. |
| Fan Speed Switch (S2) | Controls blower motor speed between High and Low settings. |
| Alarm/Buzzer | Signals the end of a "Cook" cycle when cooking time expires. |
| Cook Timer | Counts the "Cook" time of the product and signals the buzzer at the end of the cycle. |
| Door Switch | Allows the oven to operate when the doors are closed but stops the oven from operating when the doors are opened. |
| Blower Motor | Operates the oven cavity blower (convection fan). |
| Transformer | Provides 240VAC power to the oven control circuit and blower motor (480VAC models only). |
| Solid State Temperature Control | Monitors temperature sensor and regulates the oven cavity temperature by controlling 1CON to energize the heating elements when the control calls for heat. |
| High Limit Thermostat | Protects the oven from temperatures above 550°F by removing power from the heating circuit. Auto resets at 500°F. |
| 1C | Provides power to heating elements when energized. 1C is energized by the temperature control when a call for heat is made. |
| Power ON Light | Lit whenever the power switch (S1) is turned to ON or Cool Down mode. |
| Heat Light | Lit whenever temperature control is calling for heat. |
| Temperature Probe ... | Senses the oven temperature for the solid state temperature control or computer control. On oven models using the solid state control, converts the temperature into a resistance value which is monitored by the temperature control board. The probe is an RTD (resistance temperature detector) of the Thermistor type. As temperature increases the resistance value decreases. |
| Cooling Fan | Circulates cooler air from outside the oven to cool components in the control area. |
| Fuses | Protect control circuit. |

COMPONENT LOCATION

**CONTROL PANEL
(REAR VIEW)**

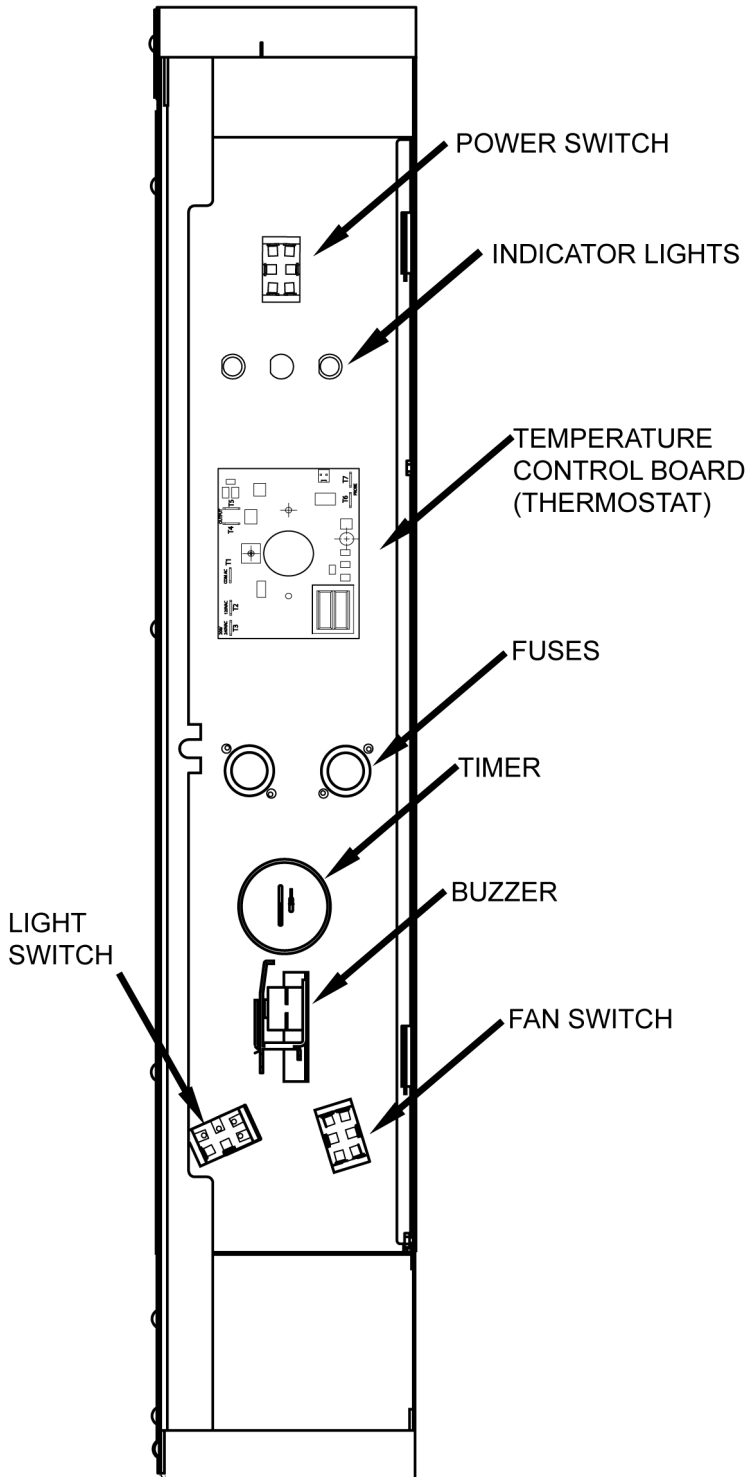

**COMPONENT PANEL
(FRONT VIEW)**

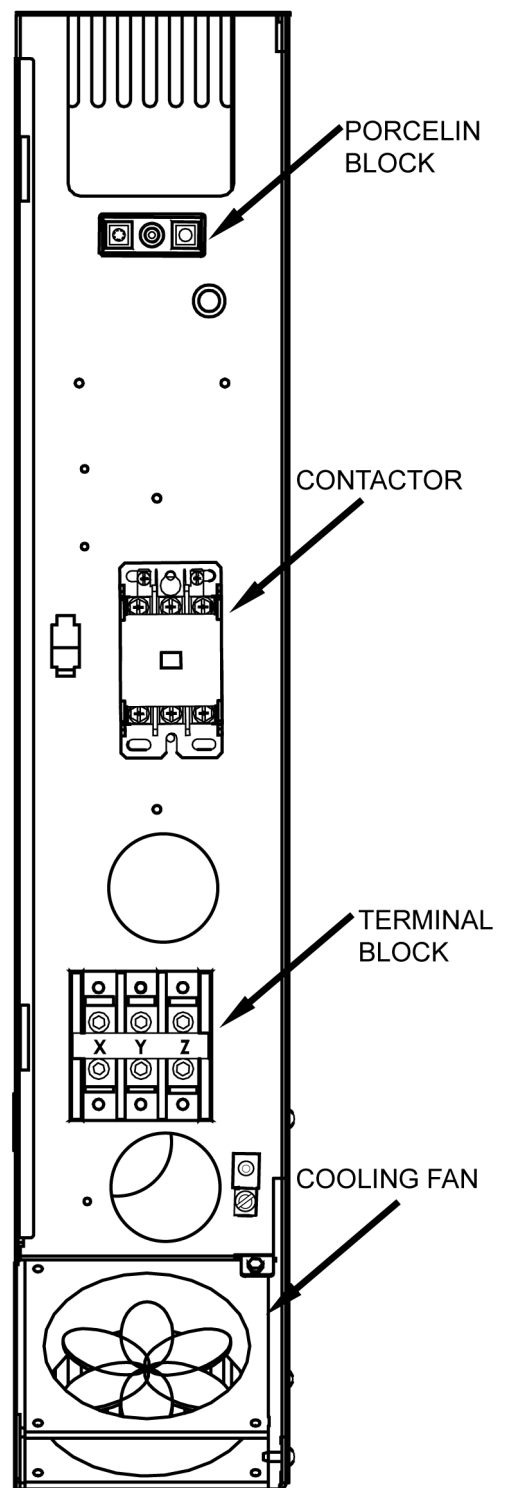

AI3782

Fig. 29

CAVITY VIEW

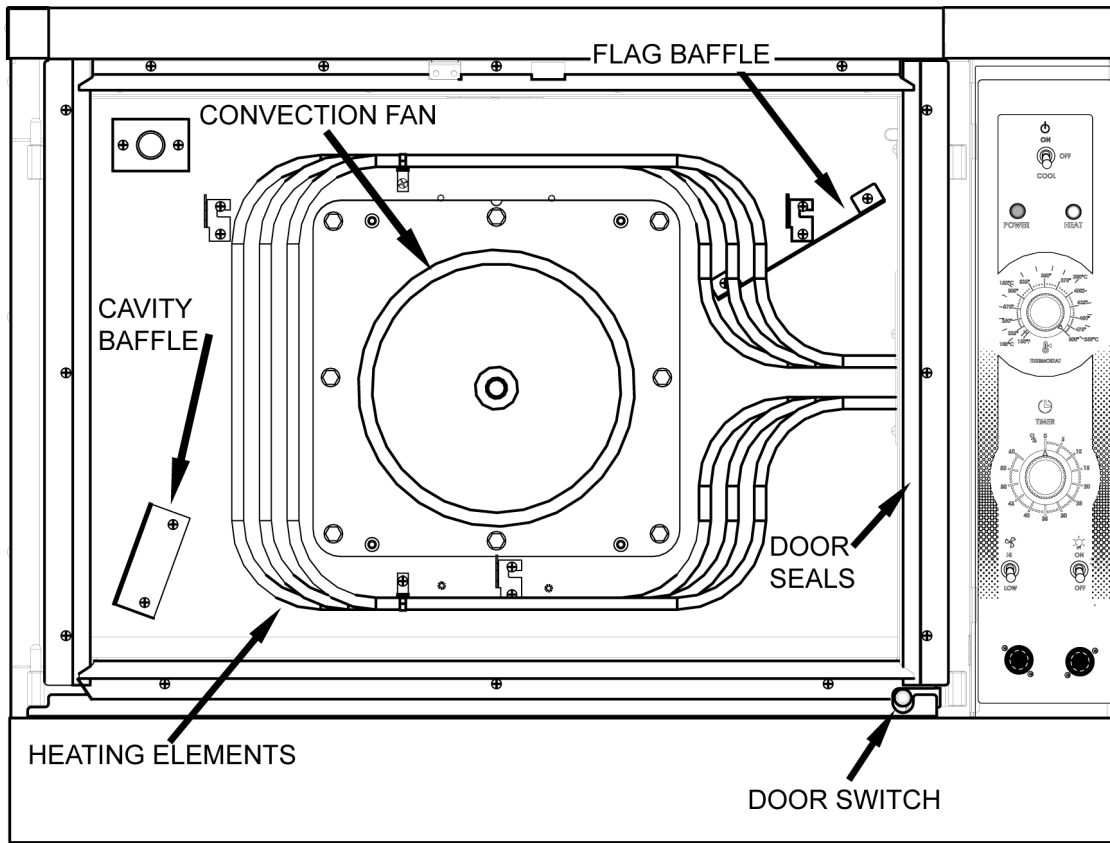

A13784

Fig. 30

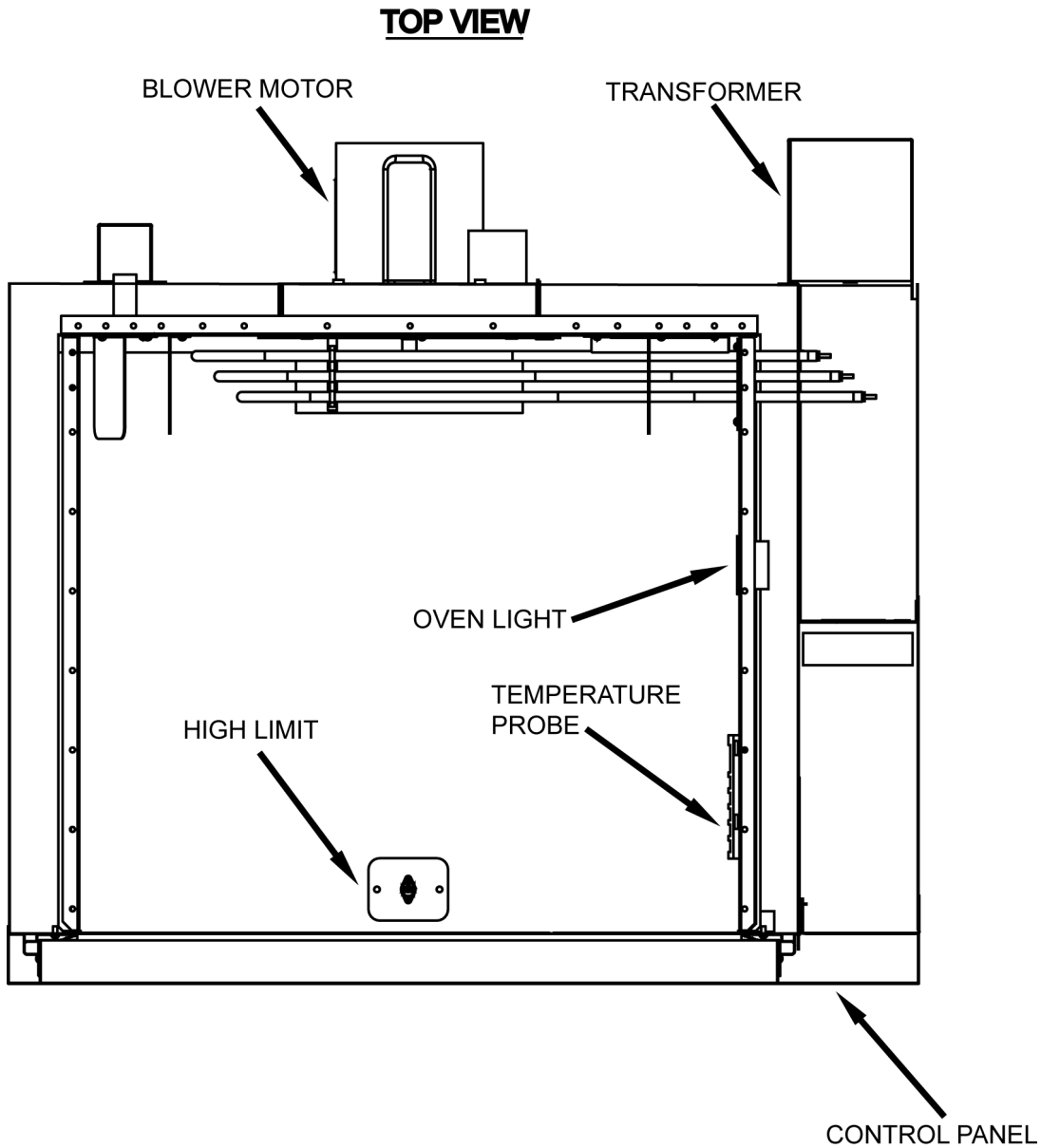

Fig. 31

SEQUENCE OF OPERATION

Cook Cycle

1. Conditions.
 - A. Oven connected to correct voltage and is properly grounded.
 - B. Power switch (S1) OFF.
 - C. Temperature dial set to lowest temperature (fully CCW).
 - D. High limit thermostat CLOSED.
2. Power switch (S1) turned ON.
 - A. Power ON light (Amber) comes ON.
 - B. Solid state temperature control energized.
 - 1) Heating elements powered and heating starts.
 - 2) 1C coil energized.
 - 3) Heat light (Clear) comes on.
 - E. Oven doors closed (door switch contacts CLOSED).
 - F. Oven cavity temperature below 140°F.

C. Blower motor energized.

NOTE: Motor speed (Hi/Low) depends on position of fan speed switch (S2).

D. Component cooling fan energized.

E. Power to oven cavity light switch (S3) wire #1. Turns cavity lights ON/OFF; does not affect "Cook" cycle.

3. Set temperature dial to desired "Cook" temperature.

4. Oven reaches set temperature.

A. Temperature control de-energizes internal relay and the normally open (N.O.) contacts OPEN.

1) Heat light goes out.

2) 1C coil de-energized.

a. Power removed from heating elements and heating stops.

5. The oven will continue to cycle on the temperature control until the doors are opened or power switch (S1) is turned to the OFF or COOL down position.

Timer Cycle, Cooking

NOTE: The "Cook" timer operates independently of the heating cycle. Additional time can be set or the timer can be turned OFF throughout the cooking cycle.

1. With the power switch turned ON, power is supplied to "Cook" timer terminal 1.

2. Set "Cook" timer to desired time.

A. Contacts 1 & 3 close, timer motor is energized and timing "down" begins.

3. Time expires on "Cook" timer.

A. Contacts 1 & 3 open, timer motor is de-energized and timing stops.

B. Contacts 1 & 4 close.

1) Buzzer energized and sounds.

NOTE: The buzzer continues to sound until the timer dial is set to the OFF position or additional time is set.

Cool Down Cycle

1. Conditions.

A. Oven is ON.

B. Oven cavity temperature needs to be lowered.

C. Doors are open (door switch contacts OPEN).

D. Fan speed switch (S2) set to "Hi".

2. Power Switch (S1) turned to COOL DOWN.

A. Power ON light (Amber) goes out.

B. Convection fan motor energized.

3. If doors are CLOSED (door switch contacts CLOSED):

A. Power ON light (Amber) comes ON.

B. Component cooling fan energized.

C. Power is supplied to:

1) "Cook" timer terminal 1. If a time is dialed, timer will operate and buzzer will sound when timer reaches zero.

2) Oven cavity light switch (S3) wire #1. Turns cavity lights ON/OFF; does not affect Cool down cycle.

4. The oven will remain in this condition until the power switch (S1).

SCHEMATICS AND WIRING DIAGRAMS

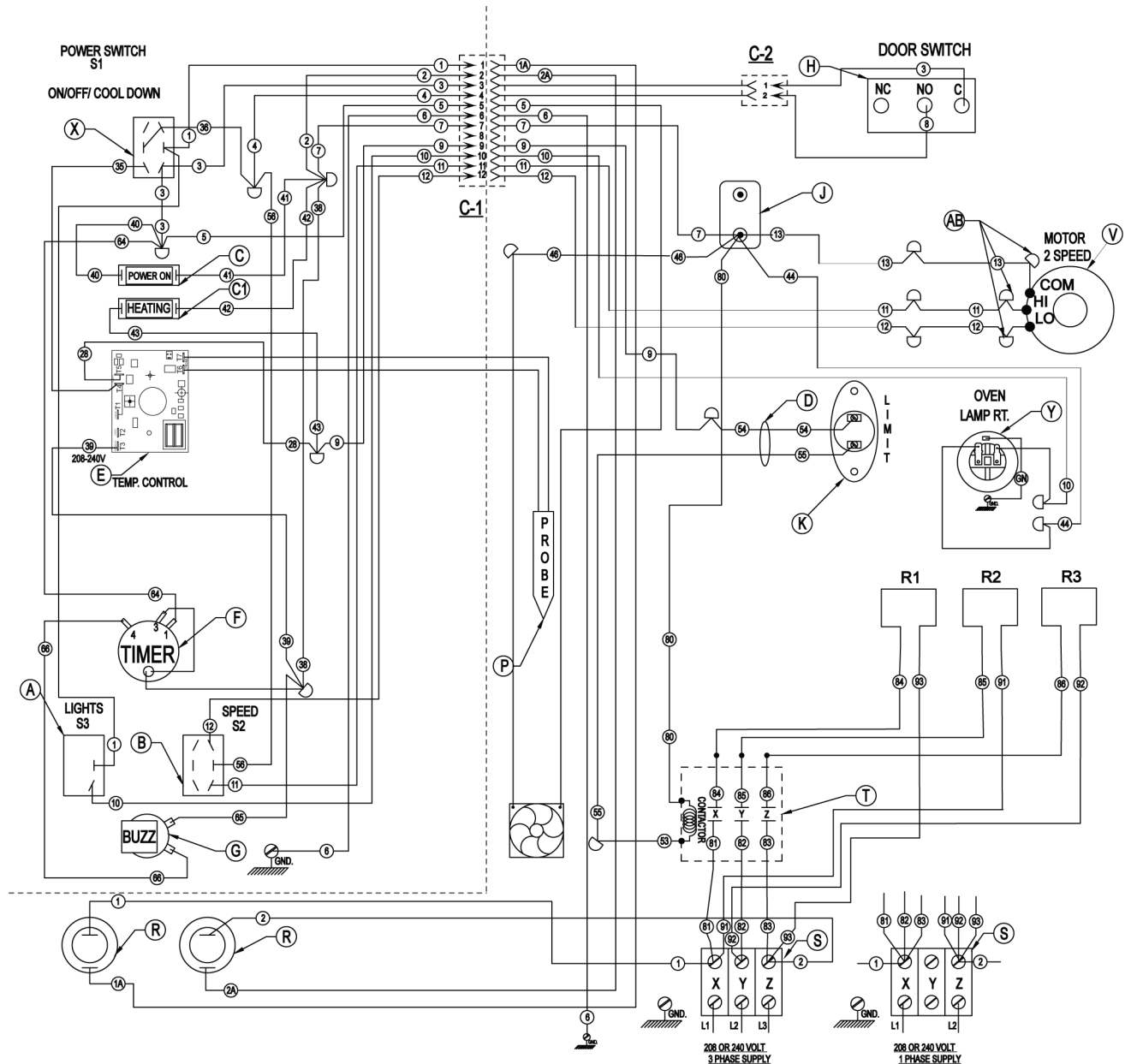

DERIVED FROM 960055 Rev C
VC3ED 208-240V WIRING DIAGRAM

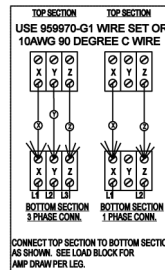

| UNIT | TOTAL KW CONN. | 3PHASE LOAD KW/PHASE | | |
|-----------------------|----------------|----------------------|------|---------|
| | | X-Y | Y-Z | X-Z |
| SINGLE | 12.5 | 4.0 | 4.0 | 4.5 |
| STACKED | 25 | 8.0 | 8.0 | 9.0 |
| NOMINAL AMPS PER LINE | | | | |
| 3 PHASE | | | | |
| | | 208V | 240V | 208/240 |
| SINGLE | 35 | 33 | 29 | 33 |
| STACKED | 70 | 66 | 58 | 66 |

SEE SCHEMATIC DECAL 960057-1

A13749

VC3ED 208-240V Wire Diagram

| VC3ED 208-240V WIRE DIAGRAM TABLE | |
|--|---|
| ITEM | DESCRIPTION |
| A | SWITCH, TOGGLE S.P.S.T |
| B | FAN SWITCH, TOGGLE D.P.D.T |
| C | LIGHT, 250V, CLEAR |
| C1 | LIGHT, 250V, CLEAR |
| D | WIRE SET, LIMIT SWITCH |
| E | TEMP. CONTROL - NCC |
| F | TIMER, 230 VOLT (1-HR, 60 HZ.) (5-HR, 60 HZ.) |
| G | BUZZER 230 VOLT |
| H | DOOR SWITCH, 2HP |
| J | BLOCK, PORCELAIN ASSEMBLY |
| K | LIMIT CONTROL 550F |
| L | ELEMENT ASSY, 12.5 KW (240 VOLT) (208 VOLT) |
| P | PROBE, THERMISTOR |
| R | FUSE & HOLDER 15A |
| S | TERMINAL BLOCK 3 POLE |
| T | CONTACTOR 40A 3 POLE |
| V | MOTOR 1/2 HP. 2 SPEED G.E. |
| X | SWITCH, TOGGLE D.P.D.T. (CO) |
| Y | OVEN LAMP, 40W, 230V |
| AB | WIRE NUT BLUE |

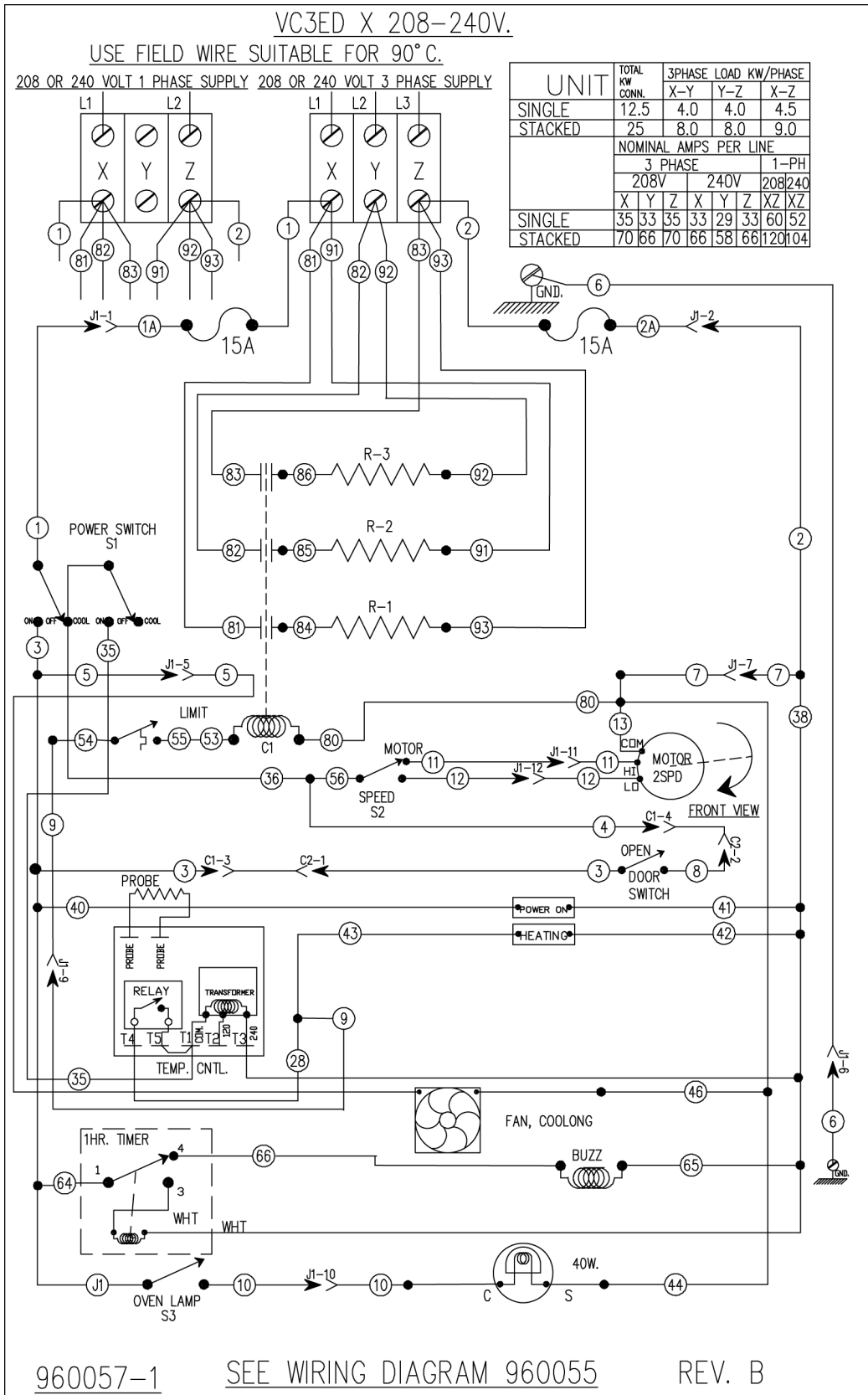

AI3757

VC3ED 208-240V SCHEMATIC

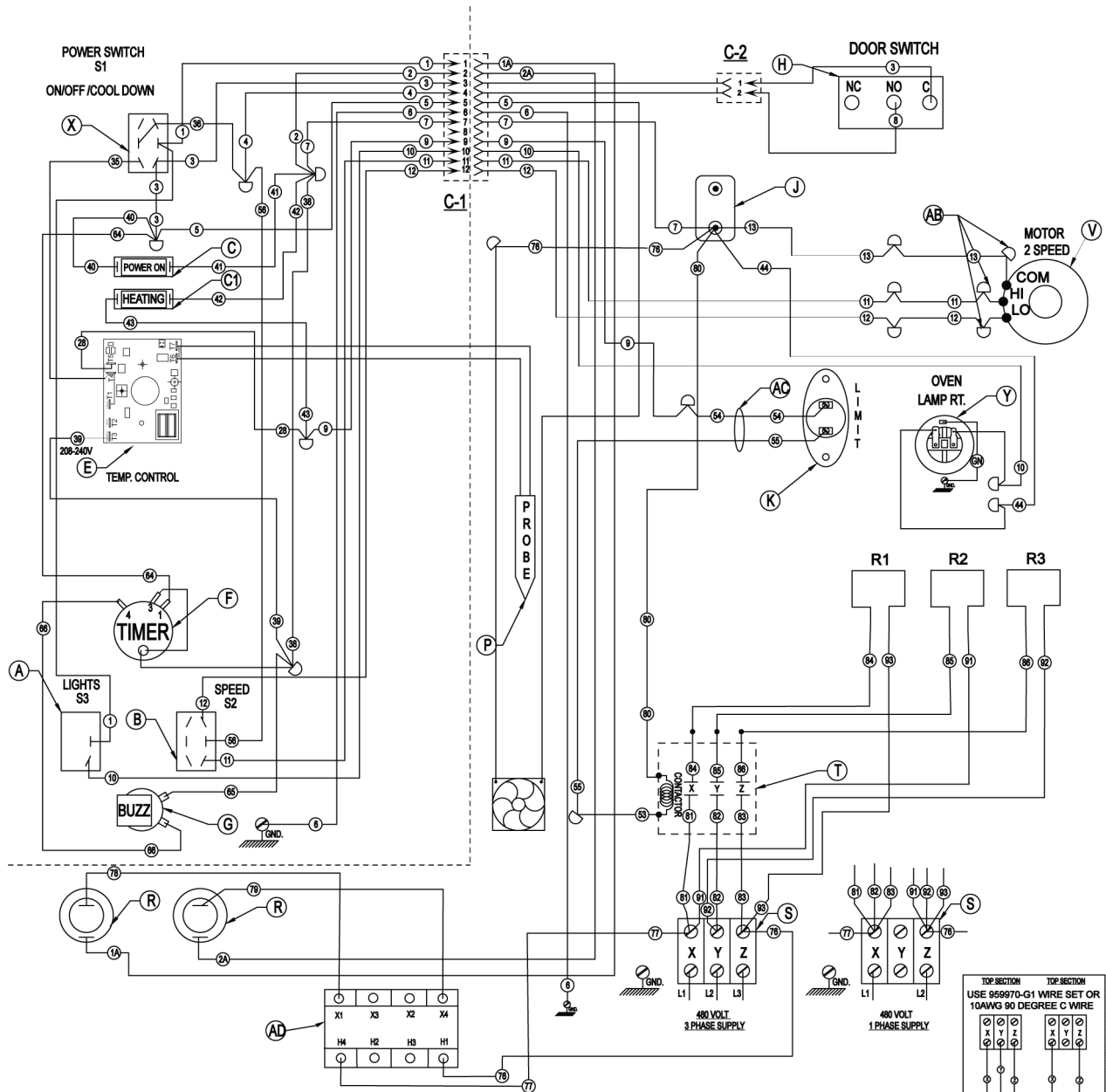

DERIVED FROM 960056 VC3ED
Rev C 480V WIRING DIAGRAM

| UNIT | TOTAL KW CONN. | 3PHASE LOAD KW/PHASE | | |
|-----------------------|----------------|----------------------|------|------|
| | | X-Y | Y-Z | X-Z |
| SINGLE | 12.5 | 4.0 | 4.0 | 4.5 |
| STACKED | 25 | 8.0 | 8.0 | 9.0 |
| NOMINAL AMPS PER LINE | | | | |
| | | 3 PHASE | | 1-PH |
| | | 480V | | 480V |
| SINGLE | 14.4 | X | Y | Z |
| STACKED | 28.8 | 14.4 | 15.3 | 15.3 |
| | | 28.8 | 30.6 | 30.6 |

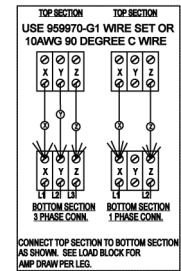

SEE SCHEMATIC DECAL 960057-1

A13748

VC3ED 480V Wire Diagram

| VC3ED 480V WIRE DIAGRAM TABLE | |
|-------------------------------|----------------------------|
| ITEM | DESCRIPTION |
| A | SWITCH, TOGGLE S.P.S.T |
| B | FAN SWITCH, TOGGLE D.P.D.T |
| C | LIGHT, 250V, CLEAR |
| C1 | LIGHT, 250V, CLEAR |

| VC3ED 480V WIRE DIAGRAM TABLE | |
|--------------------------------------|--|
| ITEM | DESCRIPTION |
| E | TEMP. CONTROL - NCC |
| F | TIMER, 230 VOLT (1-HR, 60 HZ.) (5-HR, 60 HZ.) |
| G | BUZZER 230 VOLT |
| H | DOOR SWITCH, 2HP |
| J | BLOCK,PORCELIAN ASSEMBLY |
| K | LIMIT CONTROL 550F |
| L | LCOE ELEMENT ASSY, 12.5 KW (208 VOLT) (240 VOLT) |
| P | PROBE,THERMISTOR |
| R | FUSE & HOLDER 15A |
| S | TERMINAL BLOCK 3 POLE |
| T | CONTACTOR 40A 3 POLE |
| V | MOTOR 1/2 HP. 2 SPEED G.E. |
| X | SWITCH, TOGGLE D.P.D.T. (CO) |
| Y | OVEN LAMP, 40W, 230V |
| AB | WIRE NUT BLUE |
| AC | WIRE SET, LIMIT SWITCH |
| AD | TRANSFORMER, 480 TO 240V |

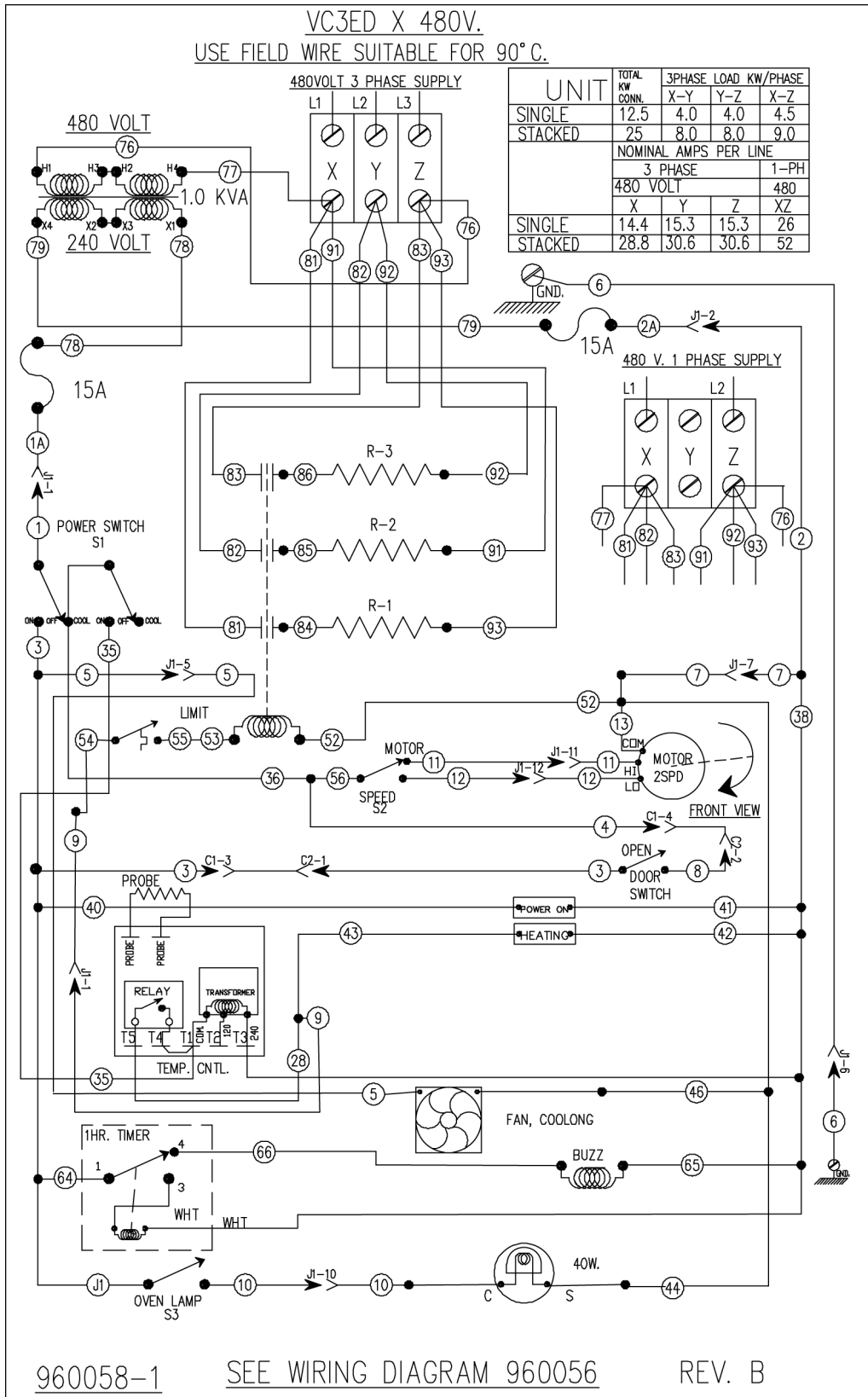

AI3776

VC3ED 480V SCHEMATIC

TROUBLESHOOTING



⚠ WARNING Certain procedures in this section require electrical test or measurements while power is applied to the machine. Exercise extreme caution at all times and follow Arc Flash procedures. If test points are not easily accessible, disconnect power and follow Lockout/Tagout procedures, attach test equipment and reapply power to test.

VC3ED

| SYMPTOMS | POSSIBLE CAUSES |
|---|---|
| Blower motor doesn't run with power switch in "ON" "COOL DOWN" or position. | <ol style="list-style-type: none"> 1. Line voltage incorrect. 2. Fuse. 3. Power switch (S1) malfunction. 4. Fan speed switch (S2) malfunction. 5. Interconnecting wiring malfunction. 6. Motor inoperative. |
| Blower motor doesn't run with power switch "ON", but oven heats. | <ol style="list-style-type: none"> 1. Door switch malfunction. 2. Fan speed switch (S2) malfunction. 3. Interconnecting wiring malfunction. 4. Motor inoperative. |
| Blower motor doesn't run in "Cool Down", but runs OK in "ON" position. | <ol style="list-style-type: none"> 1. Power switch (S1) malfunction. 2. Interconnecting wiring malfunction. |
| Excessive Heat in oven. | <ol style="list-style-type: none"> 1. Temperature probe malfunction. 2. Temperature control not calibrated. 3. Contactor malfunction. 4. Heating element(s) malfunction. |
| Low heat in oven. | <ol style="list-style-type: none"> 1. Line voltage incorrect. 2. High limit thermostat OPEN. 3. Contactor malfunction. 4. Heating element(s) malfunction. 5. Temperature probe malfunction. 6. Temperature calibration. |
| Timer inoperative or not functioning properly. | <ol style="list-style-type: none"> 1. Interconnecting wiring malfunction. 2. Timer malfunction. |
| Component cooling Fan does not run. | <ol style="list-style-type: none"> 1. Interconnecting wiring malfunction. 2. Fan motor inoperable. |

| SYMPTOMS | POSSIBLE CAUSES |
|-------------------------------------|---|
| Uneven Cooking. | <ol style="list-style-type: none"> 1. Convection Fan motor speed/direction. 2. Air flow Baffles missing or damaged. 3. Line voltage incorrect. 4. High limit thermostat malfunction. 5. Contactor malfunction. 6. Heating element(s) malfunction. 7. Doors out of adjustment. 8. Door roller out of adjustment or broken. 9. Door seals damaged. |
| Intermittent operation problems. | <ol style="list-style-type: none"> 1. Cooling fan malfunction. 2. Wiring connections loose. 3. High ambient temperatures. |
| Oven will not turn on. | <ol style="list-style-type: none"> 1. Line voltage incorrect. 2. Control circuit fuses OPEN. 3. Power switch (S1) inoperative. 4. Transformer inoperative (480V only). |
| No heat, convection fan motor runs. | <ol style="list-style-type: none"> 1. High limit thermostat OPEN. 2. Temperature probe malfunction. 3. Heating element malfunction. 4. Contactor malfunction. 5. Temperature control malfunction. |
| No power to temperature control. | <ol style="list-style-type: none"> 1. Power switch (S1) in "Cool Down". 2. Door switch malfunction. |
| Door does not seal or shut properly | <ol style="list-style-type: none"> 1. Doors out of adjustment. 2. Door catch roller out of adjustment or broken (independent doors). 3. Door seals damaged. |

Free Manuals Download Website

<http://myh66.com>

<http://usermanuals.us>

<http://www.somanuals.com>

<http://www.4manuals.cc>

<http://www.manual-lib.com>

<http://www.404manual.com>

<http://www.luxmanual.com>

<http://aubethermostatmanual.com>

Golf course search by state

<http://golfingnear.com>

Email search by domain

<http://emailbydomain.com>

Auto manuals search

<http://auto.somanuals.com>

TV manuals search

<http://tv.somanuals.com>