

# **SprayTECH<sup>®</sup>**

**BUILT TO WORK AS HARD AS YOU™**

## **Diaphragm Pumps**

1150

## **Piston Pumps**

EP2105

EP2205

EP2300

EP2300se

EP2400

EP2510

GP2605

GP2905

## **HVLP**

CS5100

CS8100

CS9100

Maxum II Gun

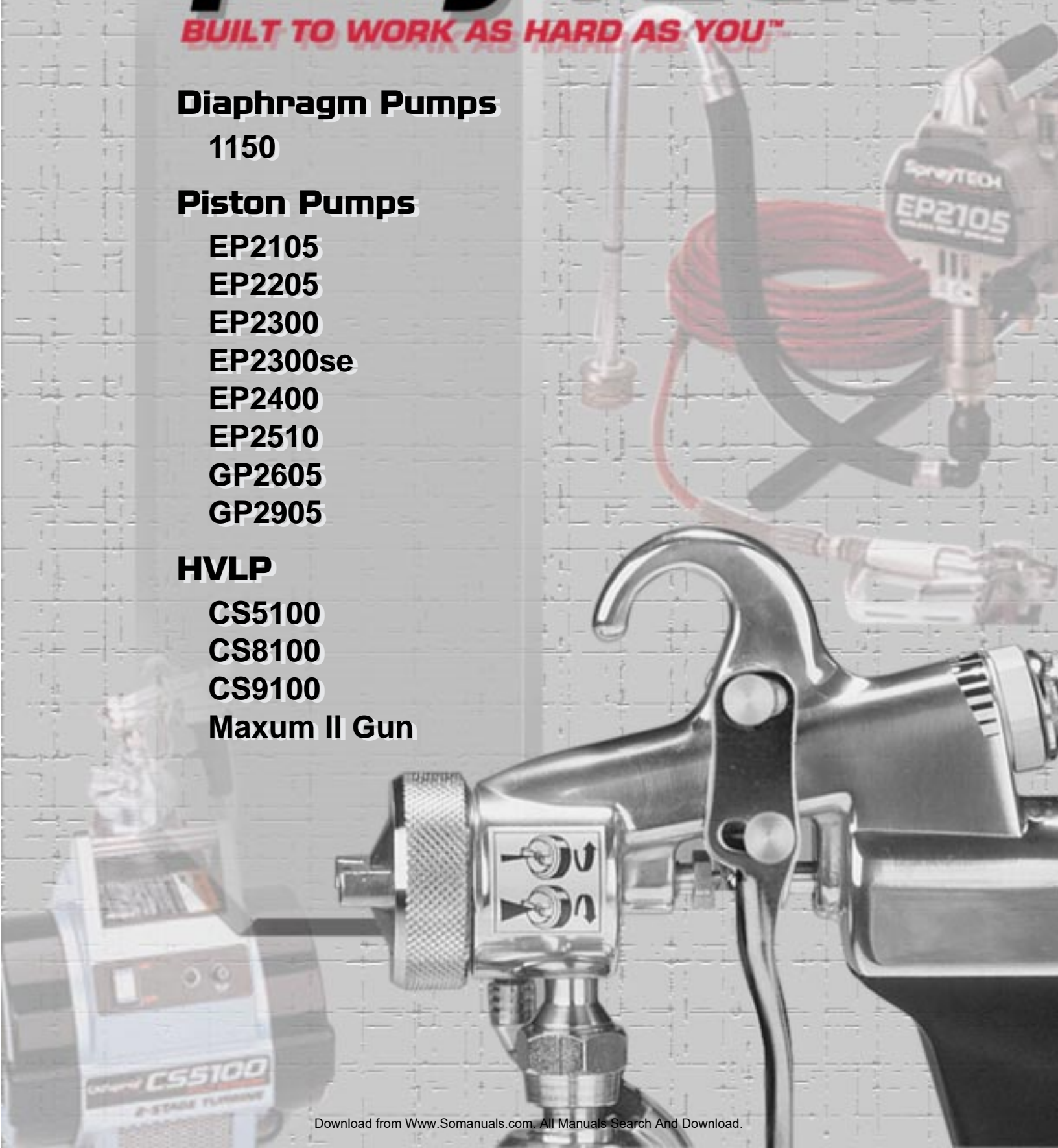



# **EP2300 Piston Pump**

## **Owner's Manual**

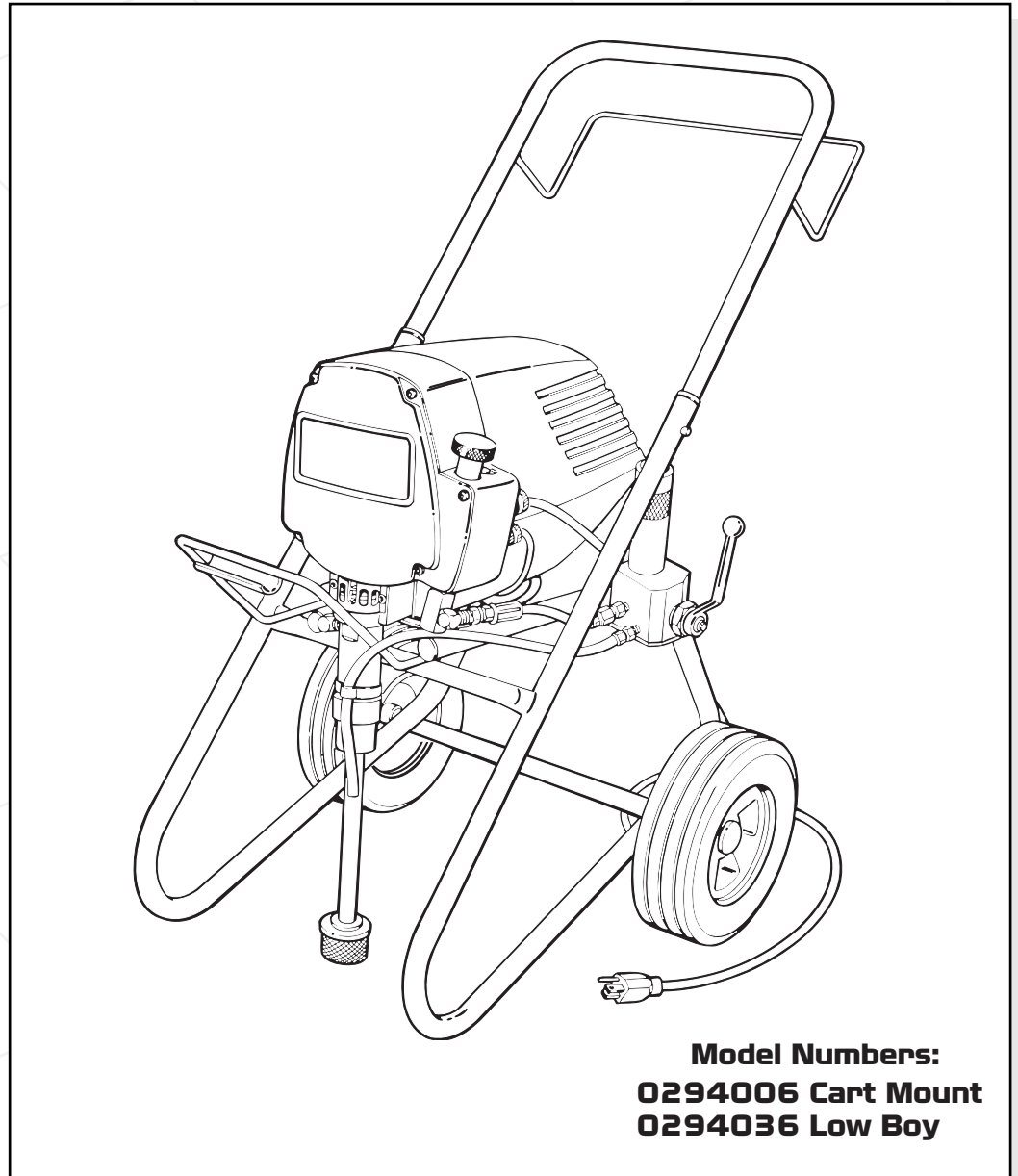

**SprayTECH**  
BUILT TO WORK AS HARD AS YOU™

**SprayTECH**  
1770 Fernbrook Lane  
Minneapolis, MN 55447

1297 © 1997 Wagner Spray Tech. All rights reserved. Form No. 0294724E

# GROUNDING INSTRUCTIONS

This product must be grounded. In the event of an electrical short circuit, grounding reduces the risk of electric shock by providing an escape wire for the electric current. This product is equipped with a cord having a grounding wire with an appropriate grounding plug. The plug must be plugged into an outlet that is properly installed and grounded in accordance with all local codes and ordinances.

## WARNING

Improper installation of the grounding plug can result in a risk of electrical shock.

If repair or replacement of the cord or plug is necessary, do not connect the green grounding wire to either flat blade terminal. The wire with insulation having an outer surface that is green with or without yellow stripes is the grounding wire and must be connected to grounding pin.

Check with a qualified electrician or serviceman if the grounding instructions are not completely understood, or if in doubt as to whether the product is properly grounded. Do not modify the plug provided; if it will not fit the outlet, have the proper outlet installed by a qualified electrician.

This product is for use on a nominal 120 volt circuit, and has a grounding plug that looks like plug illustrated in sketch A. A temporary adapter which looks like the adapter illustrated in sketch B and C, may be used to connect this plug to a 2 pole receptacle as shown in sketch B if a properly grounded outlet is not available. The temporary adapter should be used only until a properly grounded outlet (sketch A) can be installed by a qualified electrician. The green colored rigid ear lug, or the like extending from the adapter must be connected to a permanent ground such as a properly grounded outlet box cover. Whenever the adapter is used, it must be held in place by a metal screw.

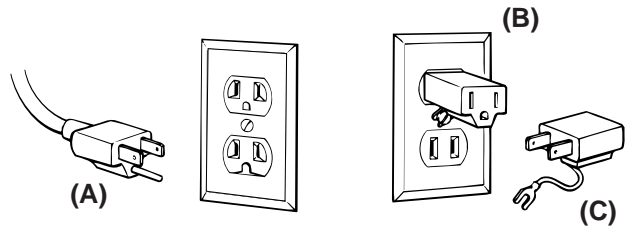

## IMPORTANT

### EXTENSION CORD SELECTION

If an extension cord is used, make sure it is of the three-conductor type with NEMA connectors so a continuous grounding circuit is provided from tool to power circuit receptacle. Also, be sure that the conductor size is large enough to prevent excessive voltage drop which will cause loss of power. A table of recommended extension cord sizes will be found below.

For nameplate ampere ratings which are between those given, use the extension cord recommended for the **NEXT** higher ampere rating.

If an extension cord is to be used outdoors it must be marked with the suffix **W-A** following the cord type designation. For example — SJTW-A to indicate it is acceptable for outdoor use.

### RECOMMENDED EXTENSION CORD SIZES FROM SERVICE ENTRANCE TO PUMP MOTOR.

NAMEPLATE AMPERE RATING

Cord Lgth.	0 to 5	6	7	8	9	10	11	12	13	14	15	16	17	18	19	20
25Ft.	18	18	18	18	18	18	16	16	16	14	14	14	14	14	12	12
50Ft.	18	18	18	18	18	18	16	16	16	14	14	14	14	14	12	12
25Ft.	18	18	18	18	18	18	16	16	16	14	14	14	14	14	12	12
100Ft.	18	18	18	16	16	16	16	16	14	14	14	14	14	14	12	12
125Ft.	18	18	16	16	16	14	14	14	14	14	14	12	12	12	12	12
150Ft.	18	16	16	16	14	14	14	14	14	12	12	12	12	12	12	12

# CONTENTS

Safety Warnings.....	4-6	Clean-up.....	12
Specifications.....	7	Maintenance.....	13
Initial Set-up.....	7	Daily Maintenance.....	13
Purging & Priming.....	8	Repacking the Fluid Section.....	14
Operation.....	9	Motor Brush Replacement.....	16
Setting the Pressure.....	9	Trouble Shooting.....	17
Using the Spray Gun.....	10	Parts List.....	19 - 29
Pressure Relief Procedure.....	10	Accessories.....	30
Prime the Sprayer with Paint.....	10	Warranty.....	Back Cover
Spraying Technique.....	11		

## SAFETY PRECAUTIONS

This manual contains information which must be read and understood before using the equipment. When you come to an area which has one of the following symbols, pay particular attention and make certain to heed the safeguard.



Important safety information indicates a hazard which may cause serious injury or loss of life.



Important information that tells how to prevent damage to equipment or how to avoid causes of minor injuries.

**Note:** Gives important information which should be given special attention.

# **WARNING**

## HAZARD

## PREVENTION

**Injection Injury** - A high pressure stream of paint produced by this equipment can pierce the skin and underlying tissues, leading to serious injury and possible amputation.

- Maximum operating range of the gun - **3000 PSI fluid pressure.**
- NEVER aim the gun at any part of the body.
- NEVER allow any part of the body to come in contact with the fluid stream. DO NOT come in contact with a fluid stream created by a leak in the fluid hose.
- NEVER put hand in front of the gun. Gloves will not provide protection against an injection injury.
- ALWAYS lock the gun trigger, shut fluid pump off and release all pressure before servicing, cleaning tip guard, changing tips, or leaving unattended. Simply turning off the motor will not release pressure in the system. The Prime Spray Valve must be turned to the  position to relieve the pressure. See Pressure Relief Procedure, Page 10.
- ALWAYS have the tip guard in place while spraying. The tip guard provides some protection against injection injuries but is mainly a warning device.
- ALWAYS remove spray tip before flushing or cleaning the system.
- Paint hose can develop leaks from wear, kinking, abuse etc. A leak is capable of injecting material into the skin. The paint hose should be inspected before each use.
- NEVER use a spray gun which does not have a trigger lock or trigger guard in place and in working order.
- All accessories must be rated at or above 3000 PSI (Includes spray tips, guns, extensions, and hose).
- In case of skin injection, see physician immediately.

**DO NOT TREAT AS A SIMPLE CUT! Injection can lead to amputation. See a physician immediately.**

**NOTE TO PHYSICIAN: Injection into the skin is a traumatic injury. It is important to treat the injury surgically as soon as possible. DO NOT delay treatment to research toxicity. Toxicity is a concern with some coatings injected directly into the blood stream. Consultation with a plastic surgeon or reconstructive hand surgeon may be advisable.**



## HAZARD

## PREVENTION

**Explosion or fire** - Solvent and paint fumes can explode or ignite causing property damage and or severe injury.

- Exhaust and fresh air introduction must be provided to keep the air within the spray area free from accumulation of flammable vapors.
- Avoid all ignition sources such as static electricity sparks, open flames such as pilot lights, hot objects such as cigarettes, and sparks from connecting and disconnecting power cords and working light switches.
- Fire extinguishing equipment must be present and in working order.
- Keep the pump away from spray area to avoid solvent and paint fumes.
- High velocity flow of material through equipment may develop static electricity. The equipment being used, and objects in and around the spray area must be properly grounded to prevent static discharge and sparks.
- Use only conductive or grounded high pressure fluid hoses for airless applications. Be sure that gun is grounded through hose connections.
- Follow the material and solvent manufacturer's safety precautions and warnings.
- WHEN FLUSHING EQUIPMENT use lowest possible pressure.



## HAZARD

## PREVENTION

**Explosion hazard incompatible materials** - May cause property damage or severe injury.

- Halogenated hydrocarbon solvents such as methylene chloride and 1,1,1 - Trichlorethane are not compatible with aluminum and may cause an explosion. If unsure of a material's compatibility with aluminum, contact your coating's supplier.
- Some spray guns and accessories cannot be used with halogenated hydrocarbon solvents. Be certain of compatibility before use with halogenated hydrocarbon solvents.
- The SprayTech EP2300 pump is **NOT** compatible for use with halogenated hydrocarbon solvents. The SprayTech G-05, G-09, and G-10 guns must not be used with halogenated hydrocarbon solvents.

**Hazardous vapors** - Paints, solvents, insecticides, and other materials may be harmful if inhaled causing severe nausea, fainting, or poisoning.

- Use a respirator or mask whenever there is a chance that vapors may be inhaled. Read all instructions with the mask to assure that it will provide the necessary protection against the inhalation of harmful vapors.

**General** - May cause property damage or severe injury.

- Read all instructions and safety precautions before operating.
- Comply with all appropriate local, state and national codes governing ventilation, fire preventive, and operation.
- The United States Government Safety Standards have been adopted under Occupational Safety and Health Act. These standards, particularly the General Standards, Part 1910 and construction Standard, Part 1926, should be consulted.
- This high- pressure airless pump is designed to be used with authorized SprayTech parts only. When using this pump with parts that do not comply with the minimum specifications and safety devices of the pump manufacturer, the user assumes all risks and liabilities.
- Before each use, check all hoses for cuts, leaks, abrasion or bulging of cover or damage or movement of couplings. If any of these conditions exist, replace the hose immediately. Never repair a paint hose. Replace it with another grounded hose.
- All hoses, swivels, guns, and accessories used with this unit must be pressure rated at or above 3000 PSI.



# SPECIFICATIONS

## MODEL EP2300

1. GPM-----2/3
2. Maximum pressure-----3000 PSI
3. Motor - electric -----1 HP
4. Amperage-----8.5 Amps
5. Cycle-----124 cycles per min.
6. Maximum Tip Size @2000 psi----- .023"  
(Latex paint)

7. Max. Hose Length @ 2000 PSI-----100 feet
8. Weight:  
LowBoy-----63 lbs.  
Cart Mount-----64 lbs.
9. Dimensions:  
Cart Mount -----30"Lx39"Hx21"W  
LowBoy-----28L x 21H x 21W  
(38H with Handle)

## INITIAL SET-UP

The SprayTech EP2300 Piston Pump unit is fully assembled upon delivery. Follow these simple steps for set-up:

### LOWBOY

1. Remove the plug from the inlet elbow on the fluid section.
2. Attach the suction set fitting into the inlet elbow on the fluid section.
3. Attach the return line to the tube fitting at the dump valve.
4. Remove protector cap on outlet fitting and install air-less hose. **DO NOT INSTALL SPRAY TIP(S) IN GUN(S) AT THIS POINT.**

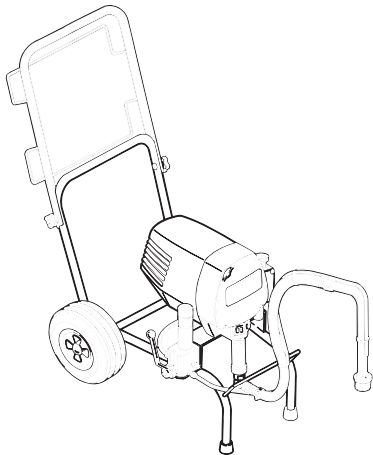

SprayTech EP2300 Low Boy Piston Pump

### CART MOUNT/LOW BOY

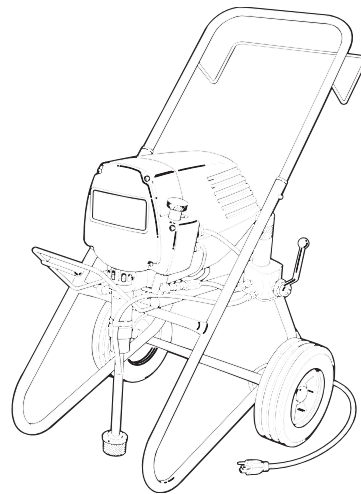

Figure 1. SprayTech EP2300 Cart Mounted Piston Pump

1. Attach handle to cart using bolts and knobs provided. Insert bolt through square hole in handle and then through hole in cart leg. Secure with knob. Repeat other side.
2. Remove protector cap on outlet fitting and install air-less hose. **DO NOT INSTALL SPRAY TIP(S) IN GUN(S) AT THIS POINT.**



Figure 2. Install Siphon Tube

# PURGING AND PRIMING

This unit is shipped with test fluid in the fluid section to prevent corrosion during shipment and storage.

For spraying with solvent-based paint, thorough flushing of this material is not necessary.

If you are going to spray with **LATEX** paint, this fluid must be thoroughly cleaned out of the system.

**KEEP SPRAY GUN LOCKED AND IN THE OFF POSITION DURING ALL THESE STEPS.**

## Purging System for Latex Paint

1. Place a bucket of soapy water under the paint suction tube. Also, have a waste container handy to catch the purged fluid.
2. Place paint return hose into the waste container.

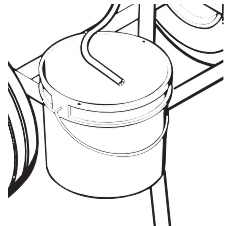

**Figure 3. Place return hose so purged fluid goes into waste container.**

**⚠WARNING** If a metal container is used, ground the gun by holding it against the edge of the container while flushing (As shown below). Failure to do so may lead to static electric discharge, which may cause a fire.

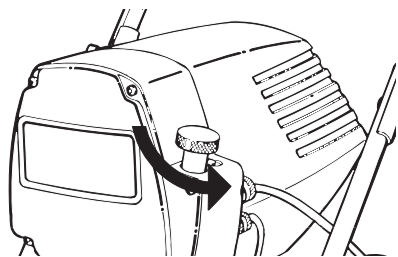
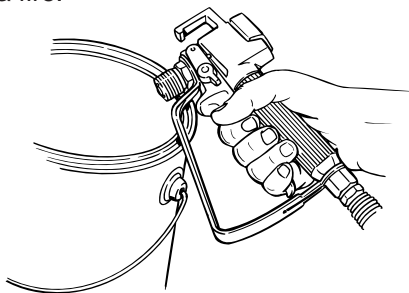

**Figure 4. Turn Pressure Control Knob Counter-Clockwise to Reduce Pressure**

4. Set Prime/Spray Ball Valve to the Prime position.

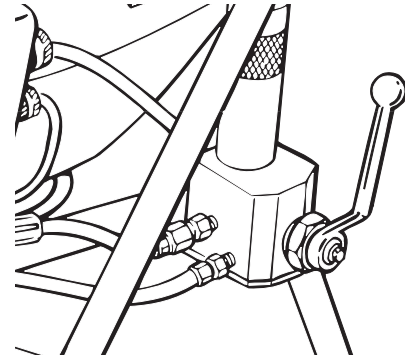

**Figure 5. Set Prime/Spray Ball Valve to Prime**

5. Turn the ON-OFF switch to the ON position.
6. Gradually increase pressure by turning Pressure Control Knob clockwise.
7. Watch for fluid to start coming through return tube. Use minimum pressure necessary to keep fluid flowing.
8. When test fluid is purged, soapy water will flow through the return. Turn pressure down to minimum and replace soapy water bucket with clear water.
9. Increase pressure again and let unit run until water running through the return line is clear.
10. Decrease pressure. Replace clean water container with bucket of latex paint.
11. Increase pressure slowly until paint comes through the return tube. Place return hose back into operating position above paint bucket. Keep recirculating until the paint coming through the return tube is free of air bubbles.
12. Decrease pressure to minimum setting (counter-clockwise). The unit is now ready to use. (See "Operating the Sprayer, page 9.)

## Purging System for Solvent-Based Paint

If you are going to spray solvent-based paint, all you need to do is purge the fluid. Thorough cleaning is not necessary as it is with latex paint.

**NOTE: KEEP SPRAY GUN LOCKED OFF DURING ALL THESE STEPS.**

1. Put full paint bucket into position.
2. Place return hose over waste container. (See Figure 3.) Attach paint hose without tip and put into waste container.
3. Set Pressure Control Knob full counter-clockwise (minimum pressure). (See Figure 4.)
4. Set Prime/Spray Ball Valve on Prime. (See Figure 5.)
5. Turn the ON-OFF switch to the ON position.
6. Turn Pressure Control Knob clockwise to increase pressure until fluid starts to come through return tube into waste container.
7. When paint starts to flow through return tube, decrease pressure to minimum setting and place return tube over paint bucket.
8. Continue recirculating until paint flowing through return tube is free of bubbles.
9. Install spray tip.
10. You are now ready to spray.

## OPERATION

Before starting spraying every day, squirt upper packing lubricant (Part No. 9992504) into slots in packing nut cover. Do not apply so much that it overflows and drips into the paint. This lubricant keeps the piston seals pliant, minimizing paint by-pass and piston wear. If unit is operated several hours a day, repeat lubrication after about 4 hours.

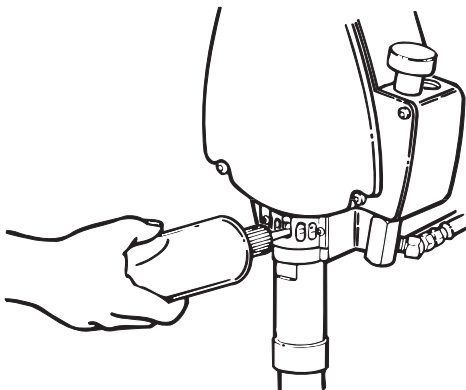

Figure 6. Oil Upper Pump Packings

For a new unit, follow purging and priming steps above. For units already in service, also purge water or solvent from the system as described above, depending on the type of paint being used.

After pump is primed and ready to spray, it may also be necessary to purge the hoses of water or solvent.

1. Set Pressure Control Knob to minimum setting (counter-clockwise).
2. Set Prime/Spray Ball Valve to Spray.
3. Be sure spray gun still has no tip installed.
4. Unlock spray gun.
5. Increase pressure by turning Pressure Control Knob clockwise.
6. Trigger gun into waste container until solvent or water is purged from the hose.
7. Decrease pressure by turning Pressure Control Knob counter-clockwise.
8. Set Prime/Spray Ball Valve to Prime, and trigger gun to be sure no pressure is left in the hose.
9. Lock gun off.
10. Install spray tip appropriate for the material being sprayed. (The thicker the paint, the larger the spray tip required.)
11. Re-set Prime/Spray Ball valve to Spray.
12. Increase pressure to maximum setting (turn Pressure Control Knob clockwise).
13. Release gun lock.
14. Trigger gun to test spray pattern. Spray against a scrap piece of pasteboard or other test surface.
15. See Setting the Pressure, below.

## Setting the Pressure

The best pressure setting will vary with the type of paint and the size and type of nozzle. The thicker the paint, the higher the pressure needed.

To find the optimum pressure setting, start with the Pressure Control Knob turned fully clockwise (maximum pressure). Gradually decrease the pressure by turning the knob counter-clockwise to the minimum level necessary to maintain the desired spray pattern and atomization.

Until you are satisfied with the spray pattern, spray on a test surface rather than on the surface to be painted.

## Using the Spray Gun

**NOTE: FOLLOW THE INSTRUCTIONS THAT CAME WITH YOUR GUN.**

## PRESSURE RELIEF PROCEDURE

**⚠WARNING** Be sure to follow the Pressure Relief Procedure when shutting the unit down for any purpose, including servicing or adjusting any part of the spray system, changing or cleaning spray tips, or preparing for clean-up.

1. Engage the gun safety latch.
2. Shut off the motor and turn the pressure control knob counterclockwise as far as possible.
3. Turn the prime/spray ball valve to prime, having a pail ready to catch the drainage or return to the paint container via the return hose.
4. Disengage the gun safety latch.
5. Hold metal part of the gun firmly to the side of a metal pail to avoid a build up of static electricity, and trigger the gun into the metal container to relieve the pressure.
6. Engage the gun safety latch.
7. Leave the prime/spray ball valve on prime, until you are ready to operate the sprayer again.

## Prime the Sprayer with Paint

1. Turn the prime/spray ball valve to prime.
2. Put the suction tube into the paint container.
3. Turn the pressure control knob counterclockwise as far as possible to the lowest pressure setting.
4. Start motor. Slowly increase pressure by turning the pressure control knob clockwise until pump begins to function. When paint begins to flow through return tube decrease pressure by turning the pressure control knob counterclockwise and then turn the prime/spray ball valve to the spray position.
5. Disengage the gun safety latch.
6. Hold a metal part of the gun firmly against and aimed into a metal waste container. Trigger the gun and hold it open while slowly increasing the pressure setting by turning the pressure control knob clockwise until the sprayer starts. Keep the gun triggered until all the air is forced out of the system and paint is flowing freely. Release the trigger and engage the safety latch.
7. Check all fluid connections for leaks. If any are found, follow the pressure relief procedure before tightening the connection.

## Spraying Technique

You can learn to spray paint as easily as you can learn to paint with a brush or roller. You can get a professional looking job in a safe manner by following the spray painting tips below.

1. Heed all **WARNINGS** and **CAUTIONS** that are listed on pages 3 thru 6 at the front of this manual. Take time out now to reread them.
2. Avoid sharp bending and kinking of the paint hose. All paint hoses should be kept clear of traffic and sharp cutting edges or objects.
3. Use the lowest pressure possible when spraying. Too much pressure shortens equipment life. It also causes faster than normal wear on the spray tip.
4. Determine the best spraying distance (distance from spray tip on the spray gun to the work). If the spray gun is held too close to the work, you will have paint buildup that will cause sags and runs. If the spray gun is held too far from the work, "fogging" will result.

The correct distance should be about 10 to 12 inches. Keep this distance for the entire length of the stroke. Of course, the shape of some work surfaces will not permit this. However, the same spraying distance should be kept whenever possible.

5. Do not move the spray gun by flexing your wrist. The result of this is shown in Figure 7. Rather, move the spray gun with a smooth stroke of the entire arm and shoulder. Maintain the same arm speed all the way through the stroke. The result of this is shown in Figure 8.

**NOTE:**  
**WHEN SPRAYING BLOCK FILLER, MASTICS OR HIGH SOLID COATING LEAVE OUT GUN FILTER AND HIGH PRESSURE FILTER SCREENS.**

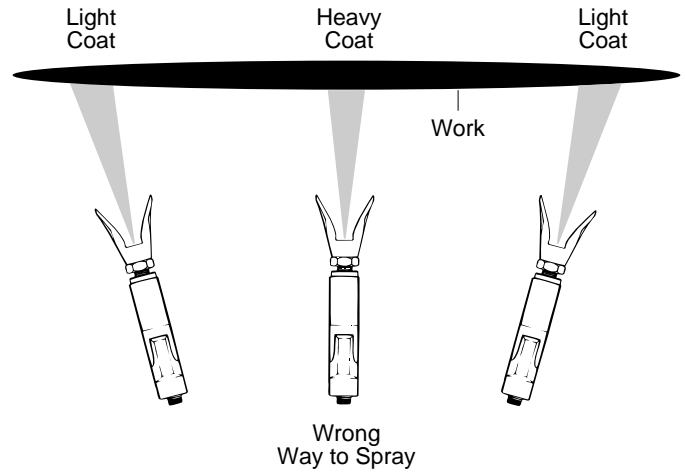

Figure 7. - Result of flexing wrist while spraying.

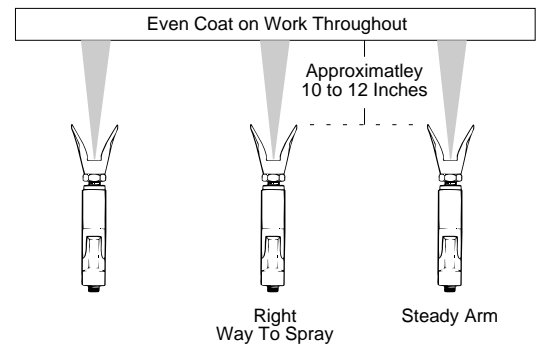

Figure 8. - Result of smooth arm stroke and steady, even speed while spraying.

6. Keep the spray gun perpendicular to the work as shown in Figure 9.

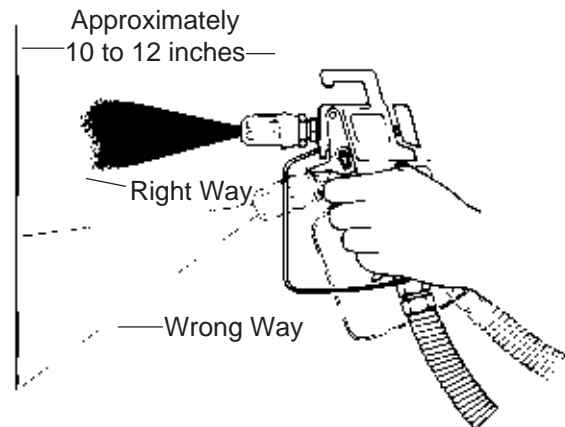
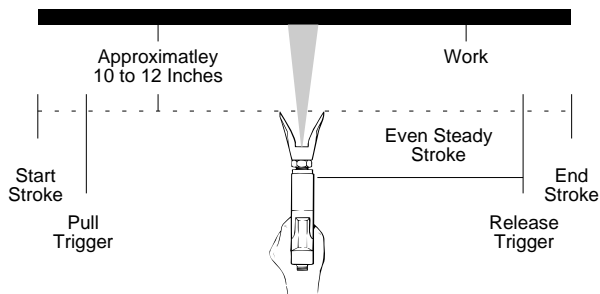

Figure 9. - Right and wrong ways to hold spray gun toward work.

7. The spray gun should be triggered (turned off and on) on each stroke. This will save paint and avoid paint buildup at the end of the stroke. However, do not trigger during the middle of a stroke. This will result in an uneven spray and splotchy work. See Figure 10 for proper triggering on a left-to-right stroke. Reverse for a right-to-left stroke.
8. Move the spray gun at a rate of speed that is comfortable for you. If you have to move your arm too fast in order to prevent excessive paint buildup, either (1) lower the pressure by turning the pressure control knob counterclockwise, or (2) use a spray tip with a smaller hole. If you have to move your arm too slow in order to get a good coating, either (1) raise the pressure by turning the pressure control knob clockwise, or (2) use a spray tip with a larger orifice. You should always keep the spray gun moving when making a stroke. Slowing down in one place will cause sags or runs.



**Figure 10. - Proper way to trigger spray gun.**

9. Overlap each stroke by about 40% to 50%. The overlap will assure a paint coating that is uniform across the work. One way to get good overlap is to point the spray gun at the edge of the last stroke.

## CLEAN-UP

**CAUTION** The pump, hose and gun should be cleaned thoroughly after daily use. Failure to do so permits material to cake, seriously affecting the performance of the unit.

**WARNING** When cleaning the pump, hose and gun with mineral spirits or any other solvent, **ALWAYS** spray at minimum pressure with the gun nozzle tip removed. Static electricity build-up may result in a fire or explosion in the presence of flammable vapors.

After daily use, paint should be flushed from the unit with solvent compatible with the material applied, and then re-flushed with mineral spirits.

1. Turn power switch to OFF.
2. Bleed off any pressure remaining in the pump by opening the dump valve.
3. Remove gun tip and clean with solution compatible with material applied.
4. Remove paint container from its position directly below siphon hose and paint strainer. Replace with a container of solvent compatible with material being applied.
5. Turn the pressure control knob counter-clockwise to the lowest pressure setting.
6. Turn power switch to ON.
7. Trigger spray gun(s) into container to flush pump, hose and gun(s) clean.
8. Turn power switch to OFF.
9. Bleed off solvent.
10. Unplug unit and store in a clean dry area.

For long-term storage, be sure to flush unit with appropriate oil before storing.

# MAINTENANCE

Routine operator maintenance on this unit is minimal. Only three daily procedures are required: (1) lubricating the upper packings, (2) cleaning the high pressure filter screen, and (3) cleaning the intake screen.

## Daily Maintenance

1. Squirt upper packing lubricant into slots in upper pump housing. Do not over-lubricate, as this will result in oil dripping into the paint. Oil approximately every four hours of operation.

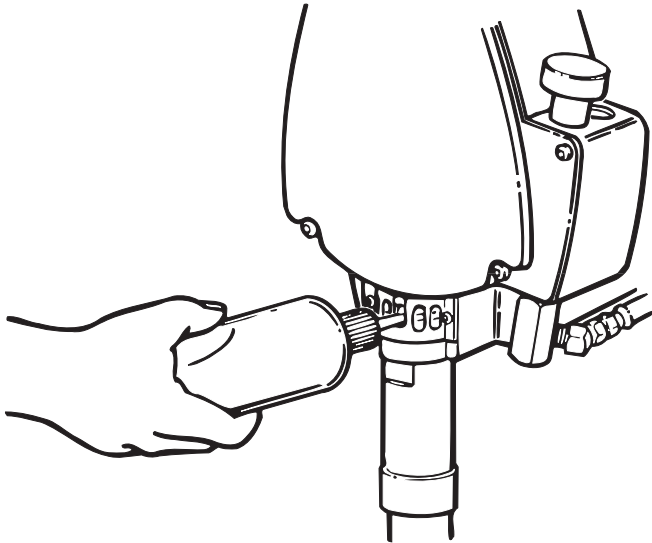

Figure 11. Squirt upper packing lubricant into upper cylinder housing every four hours.

2. Clean high pressure filter, as needed. Remove filter housing. (Filter canister is threaded into base with right-hand threads.) Take out filter element and wash thoroughly. Scrub gently with a fiber-bristle brush if necessary (**DO NOT** use a wire brush). If spraying block fillers, mastics, etc. leave filter element out.

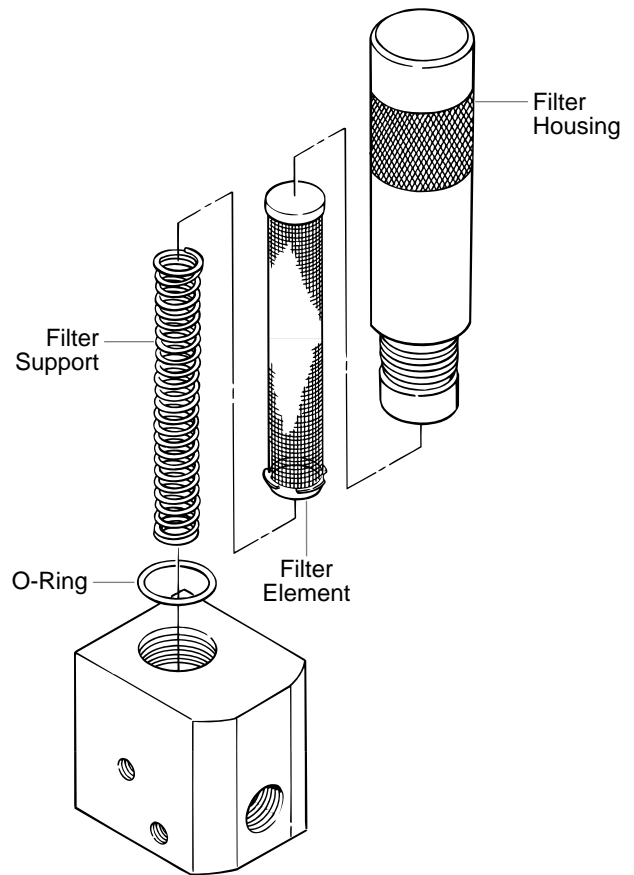

Figure 12. Remove and clean High-Pressure Filter at least daily, more often if needed.

3. Inspect paint intake screen (at bottom of paint suction tube) and wash if necessary. (Screen is threaded onto suction tube. Remove by turning counter-clockwise.)

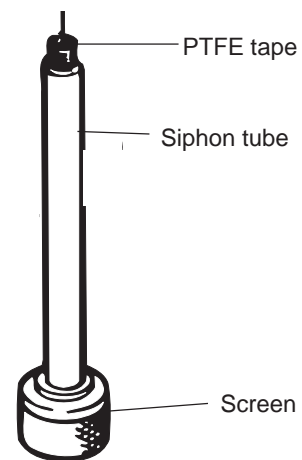
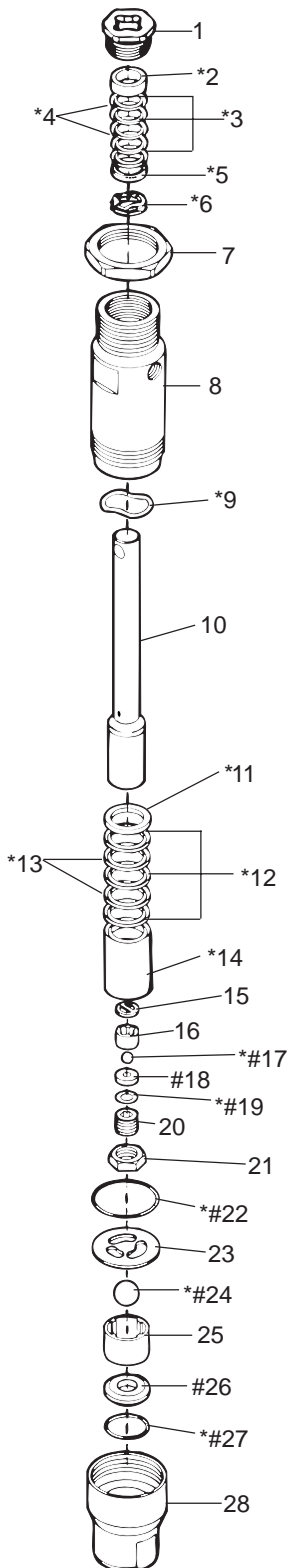

Figure 13. Clean paint intake screen daily, or more often if needed.

# Repacking the Fluid Section

A small amount of paint by-passing the piston and coming out of the slots in the upper piston housing is normal, but if it becomes excessive, or if paint pressure drops, the piston packings need to be replaced.



\* Included in Packing Kit  
P/N 0294905.

# Included in Valve Kit  
P/N 0294689.

Figure 14 - Fluid Section

**WARNING** ALWAYS follow the Pressure Relief Procedure (page 10) before starting any troubleshooting, servicing, or cleaning.

Refer to Figure 14 (left).

1. Loosen and remove siphon tube assembly by turning counterclockwise.
2. Remove front cover.
3. Remove packing nut cover.
4. Run the unit in short intervals until the connecting pin is in front of the recessed area of the housing.
5. Disconnect the power cord from the electrical supply.
6. Remove the retainer clip on the yoke.
7. Remove the connecting pin by pushing it through the yoke and piston rod.
8. Loosen and remove fluid hose.
9. Loosen large locknut (7) on upper end of fluid section.
10. Unscrew entire fluid section assembly by turning counterclockwise.

**CAUTION** Do not run motor with fluid section removed.

11. Using wrench flats on inlet valve holder (28), position fluid section vertically into vise. Tighten vise.
12. Locate wrench flats on cylinder (8). Turn cylinder counterclockwise with large adjustable wrench until it is removed from the inlet valve holder (28).
13. Remove and inspect upper O-Ring (22) in inlet valve holder. If damaged, replace when re-installing.
14. Remove inlet valve holder (28) from vise. Tap out ball stop disc (23), ball cage (25) and ball (24).

If any parts are difficult to disassemble, soak in lacquer thinner until paint softens.

15. Remove lower ball seat (26). Inspect the ball and ball seat for damage. If seat is worn or damaged it can be flipped to the unused side. Ball must be replaced if damaged or if the seat is flipped.

**NOTE:**

**Inlet and Outlet Valve carbide seats are reversible. If one side becomes worn or damaged, flip the seat to the un-used side.**

Continued on next page.



## Repacking Fluid Section

### Continued from Page 14

(Refer to Figure 14, Page 14)

16. Remove lower O-Ring (27) from inlet valve holder.
17. Place cylinder (8) in vise (on wrench flats) and tighten.

#### **CAUTION**

Do not over tighten or damage to cylinder may occur.

18. Remove packing nut (1).
19. Gently hammer piston assembly down with rubber mallet. Piston assembly will come out.

#### **CAUTION**

Hold hand under piston rod (10). Damage can occur if piston rod falls to the floor. Lower packings may also fall out.

20. Remove lower packings (12, 13) and lower female adapter (14) if they have not already fallen out.
21. Remove lower male adapter (11) and wave spring (9).
22. Remove upper packings (3, 4 ) and adapter (2, 5) and wave spring (6).
23. Insert connecting pin through hole in piston rod (10). Lock connecting pin in vise jaws so piston rod is vertical. DO NOT put piston rod itself in vise. The vise jaws will damage piston rod.
24. Remove jam nut (21).
25. Remove piston seat retainer (20) with 5/16" allen wrench.
26. Remove piston rod assembly from vise.
27. Remove washer (19), ball seat (18), ball (17), ball cage(16) and ball stop disc (15) from lower end of piston rod assembly.
28. Inspect ball, and ball seat for damage. If the seat is worn or damaged it can be flipped to the un-used side. Ball must be replaced if damaged or the seat is flipped. Washer must be replaced.
29. Hold piston assembly in vice using same procedure as step 23.
30. Insert upper ball stop disc (15), ball cage (16), ball (17), ball seat (18), and washer (19) into piston assembly.
31. Put removable loctite on piston seat retainer (20). Insert into piston assembly and tighten. Torque to 250 in./lbs.
32. Put removable loctite on jam nut (21). Tighten onto piston seat retainer. Torque to 200 in./lbs. Remove piston assembly from vice.
33. Place cylinder in vice using wrench flats and tighten.

34. Soak new leather packings in linseed oil for 5 minutes. Do not oversoak.
35. Insert wave spring (9) and lower male adapter (11) into cylinder. Remove leather packings from oil. Install leather packings (13) alternatively with UHMWPE packings (12). Insert lower female adapter (14).
36. Insert piston assembly into bottom of cylinder (8). A slight force may be required to push piston rod through packings.
37. Place O-Ring (27), lower ball seat (26), ball cage (25), ball (24) and lower ball stop disc (23) into inlet valve holder (28).
38. Put anti-seize compound on lower threads of cylinder (8). Put O-Ring (22) on cylinder. Loosen vise and tilt cylinder assembly at about a 45 degree angle. Tighten vise again.
39. Tighten foot valve holder assembly onto cylinder with an appropriate adjustable wrench until cylinder bottoms out in foot valve holder. Make sure to use wrench flats on foot valve holder to tighten completely. Torque to 40 ft./lbs.
40. Soak remaining new leather packings in linseed oil for 5 minutes. Do not oversoak.
41. Insert wave spring (6), upper male adapter (5). Remove leather packings from oil. Install leather packings (4) alternatively with UHMWPE packings (3). A tool, Wagner part #06009, may be required to compress packings down. Insert female adapter (2).
42. Install packing nut (1) and tighten until the nut bottoms out in cylinder. Torque to 25 ft./lbs. Do not over-tighten.
43. Install large locknut (7) onto upper cylinder (8) and turn until nut bottoms out on threaded section of cylinder.
44. Put anti-seize compound on upper cylinder threads.
45. Remove fluid section from vice and install into main pump housing. Piston rod (10) will align itself inside yoke.
46. Rotate fluid section slightly to align hole in yoke and hole in piston assembly. Insert connecting pin. Replace spring retainer.
47. Thread fluid section into pump housing completely, then unscrew up to 3/4 turn to align outlet elbow with fluid hose.
48. Rotate large locknut (7) clockwise until tight against drive housing.

# **!WARNING**

**NEVER OPERATE PUMP WITHOUT FRONT COVER IN PLACE.**

## **Motor Brush Replacement**

Brushes should be inspected periodically to insure uninterrupted service. Their life depends on speed as well as load.

If one of the brushes measures less than 1/4" or is worn roughly or chipped, replace both motor brushes. It is also recommended that brushes be checked when packings are replaced.

1. Disconnect power cord from electrical supply.
2. Remove the four (4) motor shroud mounting screws and remove the motor shroud.
3. Unscrew and remove brush caps holding brushes in place.
4. Remove brushes.
5. Replace with new brushes.

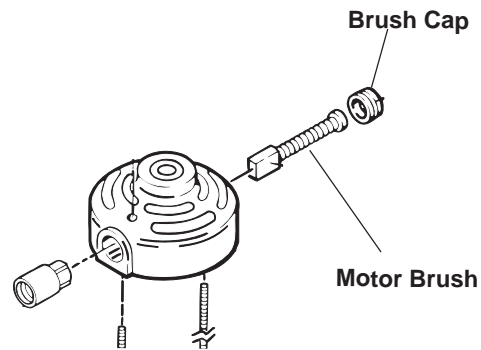

**Figure 15. Remove Brush Cap and Motor Brush**

6. Replace brush caps.
7. Replace motor shroud and screws.

# TROUBLESHOOTING

PROBLEM	CAUSE	REMEDY
Unit will not run	Blown panel fuse or tripped breaker Unit not plugged in Pressure control knob set too low Faulty or loose wiring  Worn motor brushes Clogged Tip or Filters Faulty On/Off switch fuse	Check and replace/reset  Plug in Turn knob to higher pressure Inspect/Take to SprayTech Authorized Service Center  Check and replace brushes Clean tip and filters. Take to SprayTech Authorized Service Center
Unit will not prime	Dried out piston packings  Pump inlet screen plugged Air in pump or hose  Packings worn Fluid is too viscous  Siphon tube clogged Siphon tube air leak Clogged tip	Remove siphon tube and feel lower ball check to be sure it is free to move off its seat. Place full cup of paint thinner over end of fluid section and turn on pump. Remove and clean. Hold gun trigger in open position and run unit about 10 seconds until air is purged Check for siphon tube leak Replace packings. (See page 14) Prime pump with compatible solvent. Bring pump up to pressure. Carefully remove pump from solvent container and immerse inlet tube in heavy material to be sprayed. With nozzle tip removed, trigger gun until heavy material appears at gun. Replace nozzle tip. Remove and clean Check connection and seal Relieve pressure, remove tip and clean.
Unit will not build or maintain pressure	Pressure adjusting knob not properly set Pump inlet strainer dirty Valve balls or seals worn or dirty Air in pump or hose  Packings worn Worn spray tip Internal leakage  Fluid leak  Fluid too viscous  Spray tip too large	Adjust to increase pressure  Clean Replace or clean Hold gun trigger in open position and run about 10 seconds until air is purged Replace (See Page 14) Replace (Follow direction supplied with gun) With gun trigger closed, allow unit to pump up to pressure and shut off if pump momentarily starts. Internal leak is indicated and fluid section rebuild is necessary. (See Page14) Check for external leaks including hydraulic fittings attached to pressure control housing Consult manufacturers recommendations on paint container label Change tip
Fluid leakage at upper end of fluid section	Upper packing worn  Piston rod worn	Relieve pressure and tighten packing take up nut or replace packings. (See Page 14) Replace. (See Page 14)

# TROUBLESHOOTING CONTINUED

<b>PROBLEM</b>	<b>CAUSE</b>	<b>REMEDY</b>
Poor spray pattern	Tip too large Pressure adjustment wrong Insufficient fluid delivery Fluid too viscous	Change to smaller tip Adjust pressure control knob Clean all strainers and filters Add solvent according to manufacturer's recommendations
Unit lacks power	Pressure adjustment low Improper voltage supply	Increase pressure Reconnect input voltage for 115 AC
Blow Fuses at Pump	Excessive pressure Circuit Breaker Overtightened packings gear box, linkage or motor failures	Take to SprayTech Authorized Service Center Repair/replace malfunctioning parts

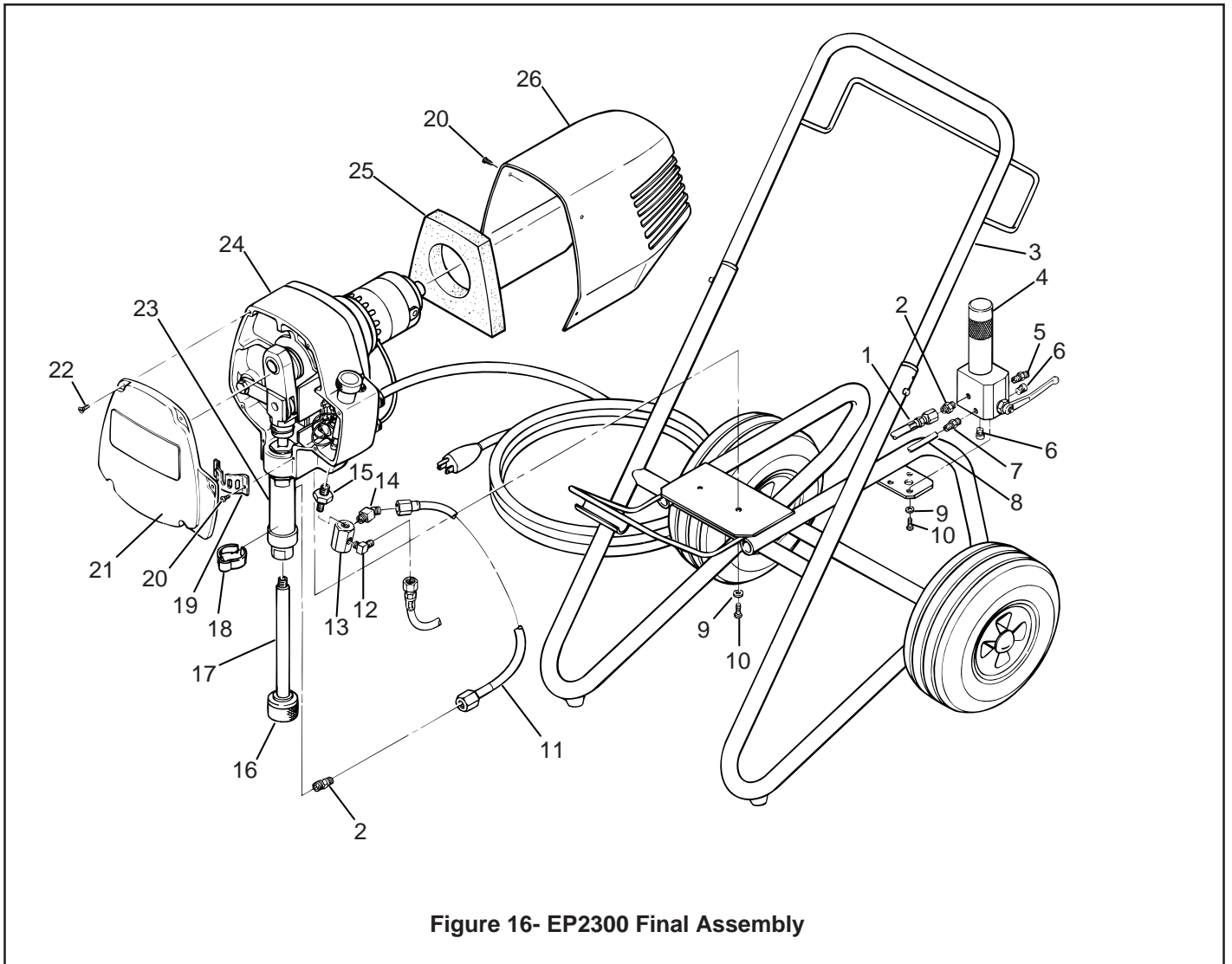

Figure 16- EP2300 Final Assembly

## EP2300 FINAL ASSEMBLY - FIGURE 16

ITEM	PART NO.	DESCRIPTION	QTY	ITEM	PART NO.	DESCRIPTION	QTY
1	0294611	Hose, Fluid, 1/4 NPT	1	14	9885547	Elbow 45°	1
2	05045	Nipple	2	15	02208	Transducer Assembly (See Figure 22)	1
3	-----	Cart Assembly (See Figure 18)	1	16	02975	Strainer	1
4	0294220	Filter/Dump Valve Assembly (See Figure 26)	1	17	0279473	Siphon Tube Assembly	1
	0294229	Optional Filter Assembly (Includes Items 2, 4, 5, 6 & 7)		18	0294584	Return Tube Clamp	1
5	02518	Nipple	1	19	0294393	Cover, Packing Nut	1
6	51055	Plug, Pipe	2	20	9802515	Screw	6
7	9885563	Fitting, Tube	1	21	0294425	Cover, Front	1
8	0294416	Tube, Return	1	22	9802511	Screw	5
9	51357	Washer, Lock	4	23	0294133	Fluid Section Assembly (See Figure 21)	1
10	52183	Bolt, Hex. Head	4	24	-----	Drive Assembly, 23 Series (See Figure 25)	1
11	13549	Hose, Fluid	1	25	0294344	Baffle	1
12	12440	Elbow, 90°	1	26	0294405	Shroud, Motor	1
13	0294415	Manifold	1				

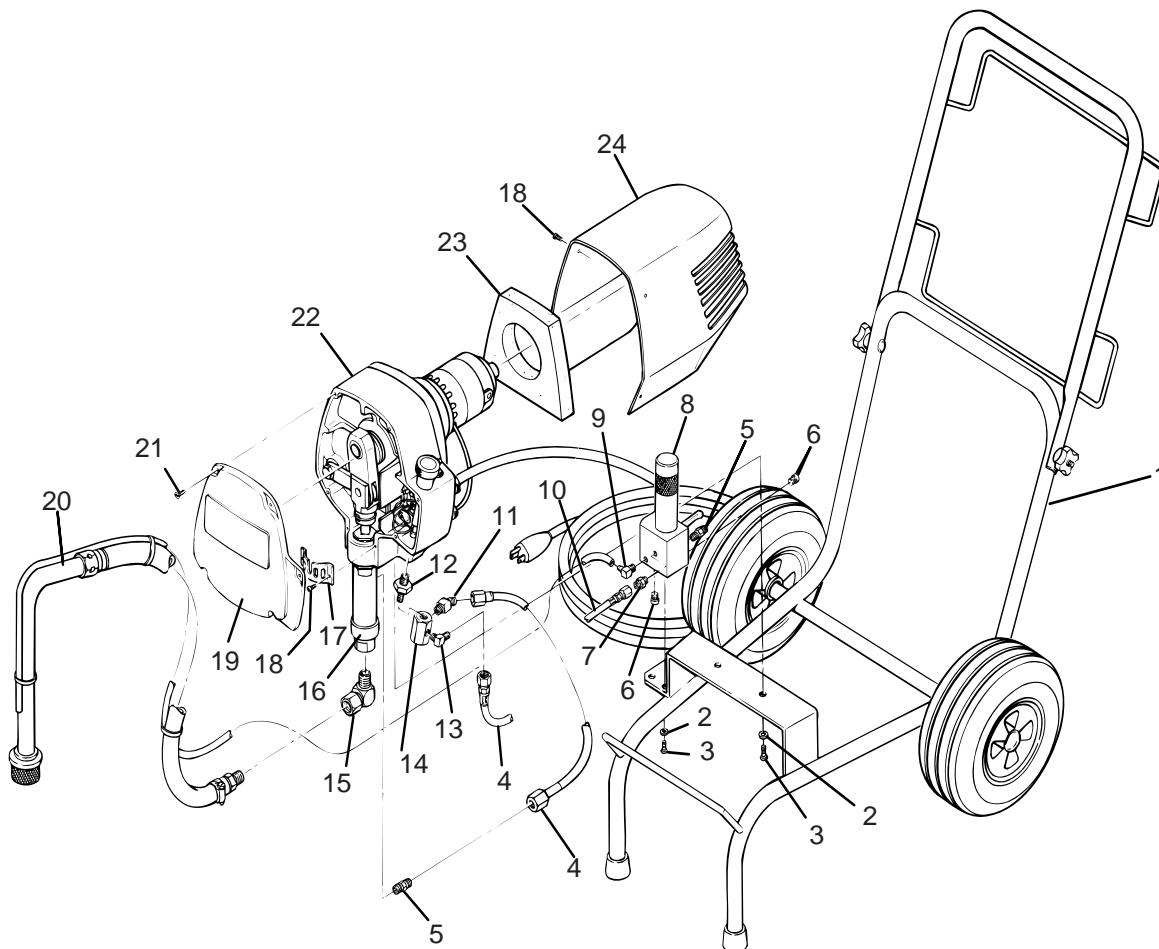

Figure 17- Low Boy Final Assembly

## EP2300 LOW BOY FINAL ASSEMBLY - FIGURE 17

ITEM	PART NO.	DESCRIPTION	QTY.	ITEM	PART NO.	DESCRIPTION	QTY.
1	-----	LowBoy Cart Assembly (See Figure 19)	1	13	12440	Elbow, 90°	1
2	51357	Washer, Lock	4	14	0294415	Manifold	1
3	52183	Bolt, Hex. Hex.	4	15	0090447	Elbow, 90°	1
4	13549	Hose, Fluid	2	16	0294133	Fluid Section Assembly (See Figure 21)	1
5	05045	Nipple	2	17	0294393	Cover, Packing Nut	1
6	51055	Plug, Pipe	2	18	9802515	Screw	6
7	02518	Nipple	1	19	0294425	Cover, Front	1
8	0294220	Filter/Dump Valve Assembly (See Figure 26)	1	20	0294185	Suction Set (See Figure 23)	1
	0294228	Optional Filter Assembly ( Includes Items 5, 6, 7, 8, & 9)		21	9802511	Screw	5
9	9885559	Elbow, 90°, Return Line	1	22	-----	Drive Assembly 23 Series (See Figure 25)	1
10	0294424	Tube, Return	1	23	0294344	Baffle	1
11	9885547	Elbow, 45°	1	24	0294405	Shroud, Motor	1
12	02208	Transducer Assembly (See Figure 22)	1				

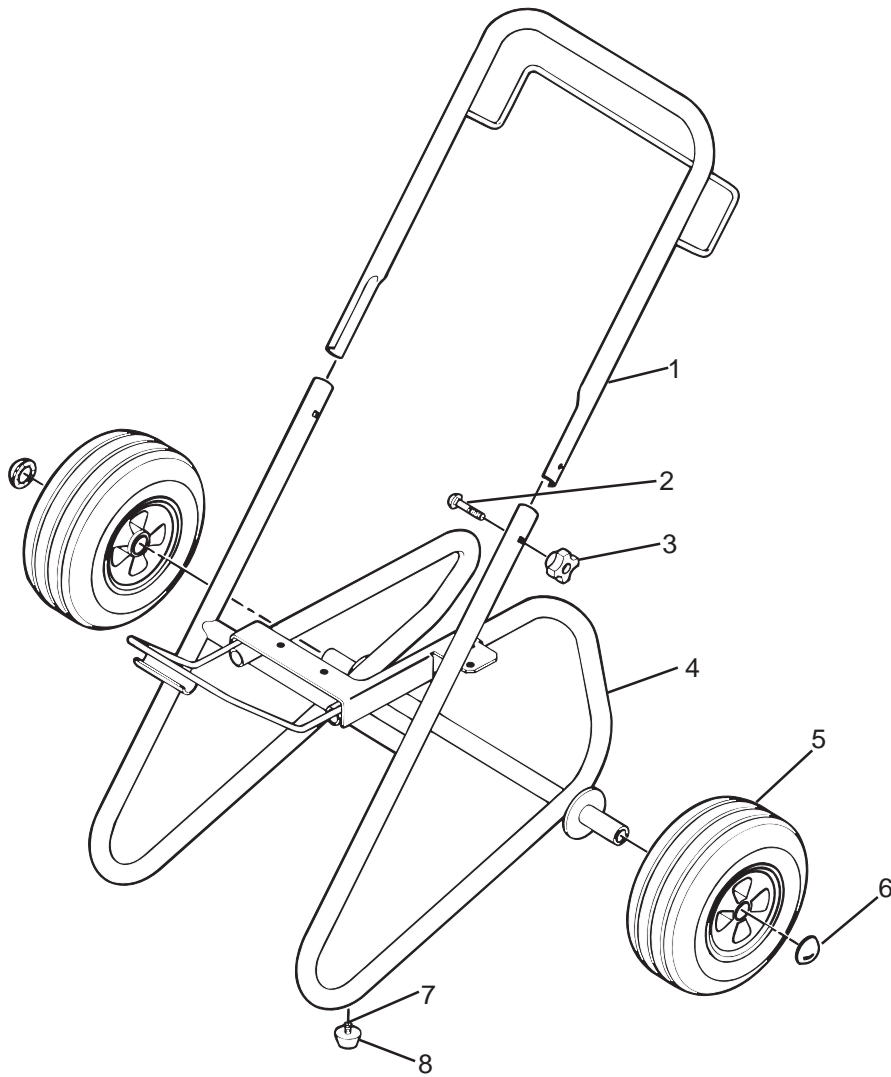

Figure 18 - Cart Assembly

## CART ASSEMBLY - FIGURE 18

ITEM	PART NO.	DESCRIPTION	QTY.	ITEM	PART NO.	DESCRIPTION	QTY.
1	0279324	Handle	1	6	9890104	Cap, Axle	2
2	9802518	Bolt	2	7	54458	Screw	2
3	0288661	Knob	2	8	13538	Bumper	2
4	0294558	Frame, Cart	1		0294534	Spacer, Wheel (NOT SHOWN)	4
5	0270318	Wheel					

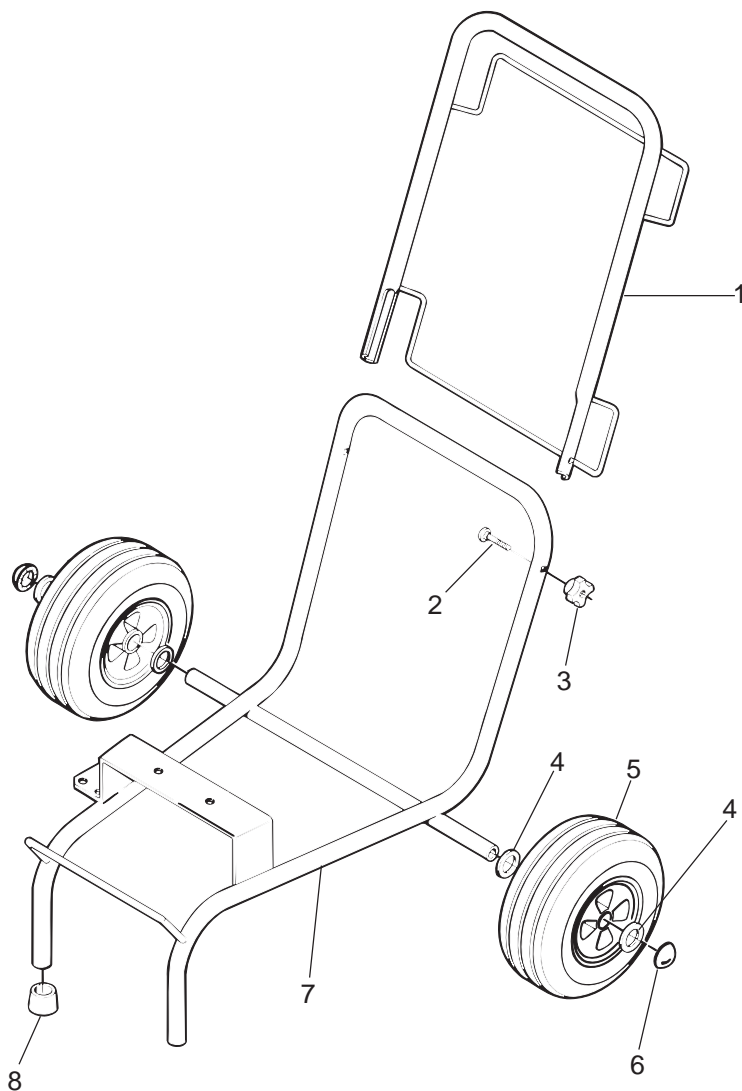

Figure 19- LowBoy Cart Assembly

## LOWBOY CART ASSEMBLY - FIGURE 19

ITEM	PART NO.	DESCRIPTION	QTY.	ITEM	PART NO.	DESCRIPTION	QTY.
1	0294445	Handle, Cart	1	5	0270318	Wheel	2
2	9802518	Bolt, Carriage	2	6	9890104	Cap, Hub	2
3	0288661	Knob, Handle	2	7	0294579	Cart	1
4	0294534	Spacer, Wheel	4	8	0270343	Foot, Rubber	2



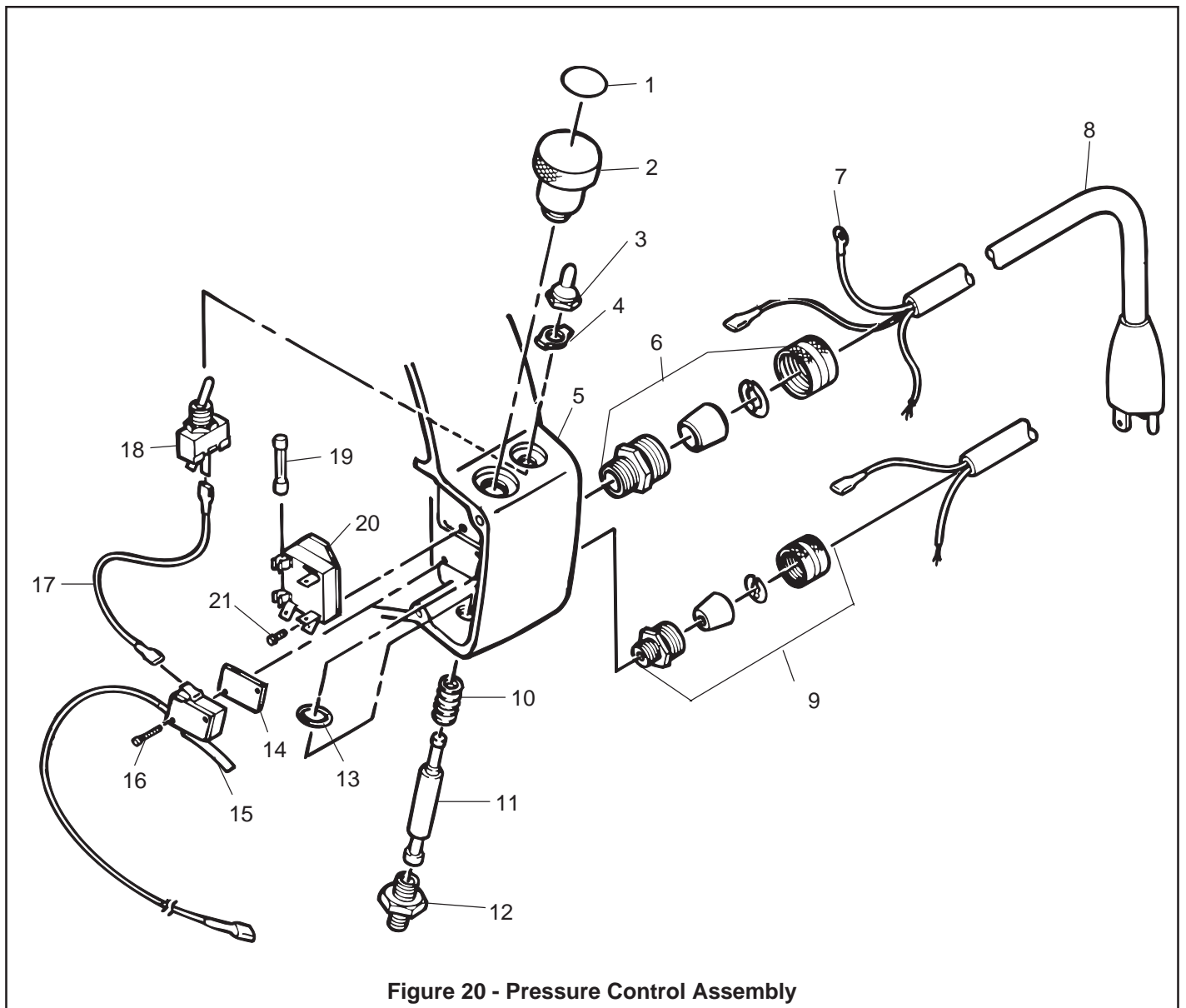
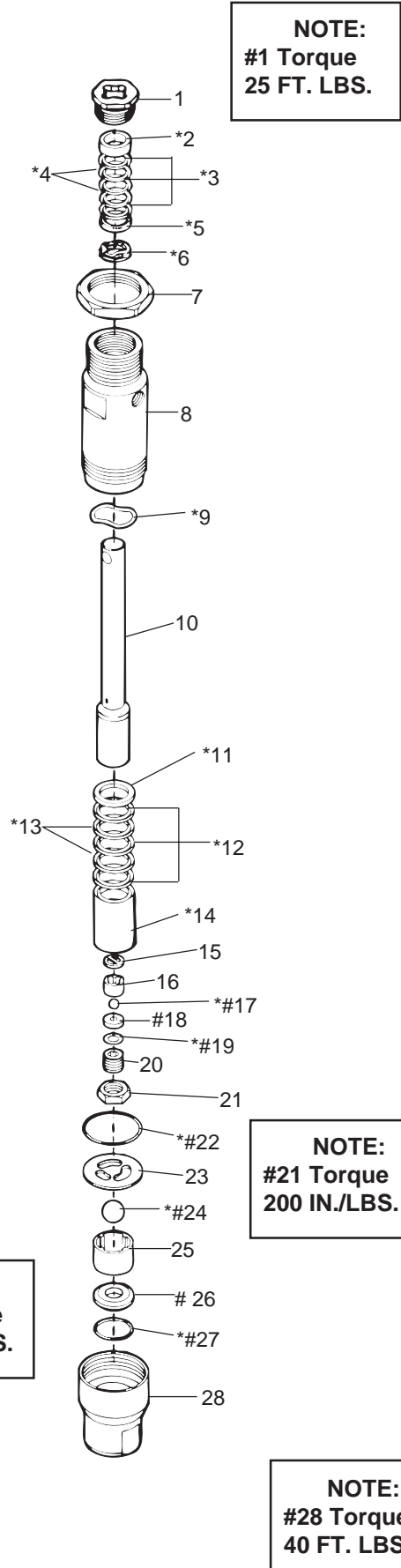

Figure 20 - Pressure Control Assembly

## PRESSURE CONTROL ASSEMBLY - FIGURE 20

Item	Part No.	Description	Qty.	Item	Part No.	Description	Qty.
1	0294837	Pressure Increase Label	1	12	02208	Transducer assy. (See Figure 23)	1
2	0295426	Knob	1	13	9822522	Retainer ring	1
3	02585	Toggle Boot	1	14	03662	Switch spacer	1
4	0089986	On/Off plate	1	15	0294132	Pressure Switch Assembly	1
5	0294349	Housing	1	16	9800604	Screw	2
6	0275703	Strain relief	1	17	9851311	Lead wire	1
	9850630	Strain relief (CSA)		18	53280	On/Off switch	1
7	52671	Ring terminal	1	19	53732	Fuse (10 amp)	1
8	0294428	Cord set	1	20	18066	Relay (25 amp)	1
	02491	Cord Set (CSA)	1	21	50520	Screw	3
9	9850629	Strain relief	1				
10	02712	Spring	1				
11	0294359	Plunger	1				

# 0294133 FLUID SECTION ASSEMBLY FIGURE 21



**NOTE:**  
#1 Torque  
25 FT. LBS.

**NOTE:**  
#20 Torque  
250 IN. LBS.

**NOTE:**  
#21 Torque  
200 IN./LBS.

**NOTE:**  
#28 Torque  
40 FT. LBS.

ITEM	PART NO	DESCRIPTION	QTY.
1	0294319	Packing nut	1
2	0294377	Adapter	1
3	08180	Packings, UHMWPE	3
4	00078	Packings, leather	2
5	0294376	Upper male adapter	1
6	0294379	Wave spring	1
7	00302	Locknut	1
8	0294318	Cylinder	1
9	13364	Wave spring	1
10	0294316	Piston rod	1
11	0294326	Lower male adapter	1
12	08070	Lower packings, UHMWPE	3
13	09091	Lower packings, leather	2
14	0294375	Lower female adapter	1
15	13458	Upper ball stop disc	1
16	13357	Upper ball cage	1
17	50164	Upper ball	1
18	13359	Upper ball seat	1
19	09446	Washer	1
20	13481	Piston seat retainer	1
21	13482	Jam nut	1
22	13381	O-ring	1
23	13380	Lower ball stop disc	1
24	51519	Lower ball	1
25	00311	Lower ball cage	1
26	00310	Lower ball seat	1
27	00203	O-ring	1
28	13403	Inlet valve holder	1

## REPAIR KITS

KIT NO.	DESCRIPTION
0294905	Packing Kit (* Items Included)
0294689	Valve Kit (# Items Included)

Figure 21 - Fluid Section

## TRANSDUCER ASSEMBLY - FIGURE 22

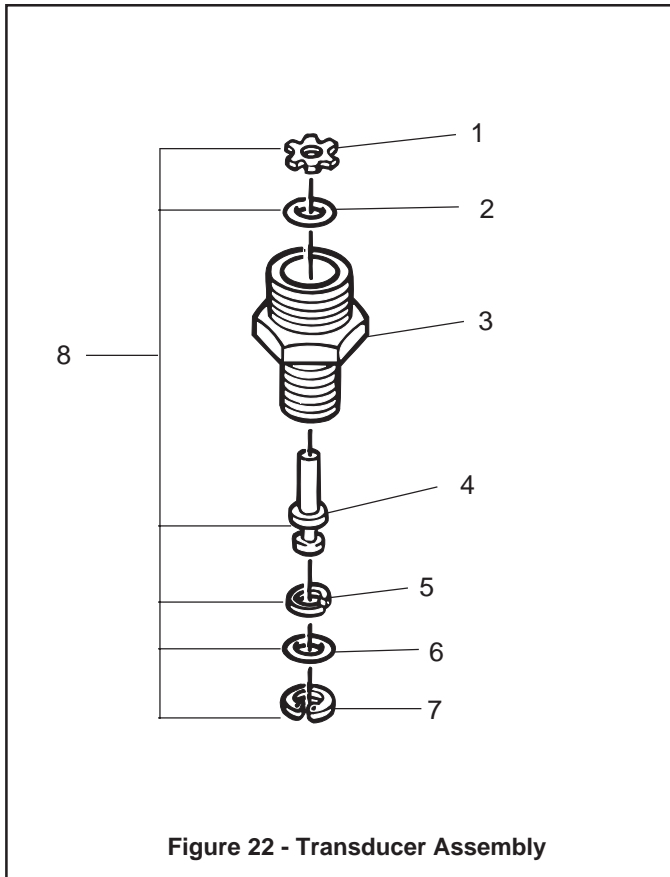

Figure 22 - Transducer Assembly

ITEM	PART NO.	DESCRIPTION	QTY
1	50431	Retainer ring	1
2	50504	O-ring	1
3	02216	Transducer body	1
4	02232	Piston	1
5	50512	Back-up ring	1
6	50482	O-ring - Standard material	1
	02305*	O-Ring - Lacquer based material	1
7	50423	Retainer ring	1
8	02283	Transducer Packing Kit Includes Items 1, 2, and 4 through 7.	

\* Optional - for lacquer based material

**NOTE:** When paint begins to leak through the weep hole on the transducer assembly, repack the transducer assembly.

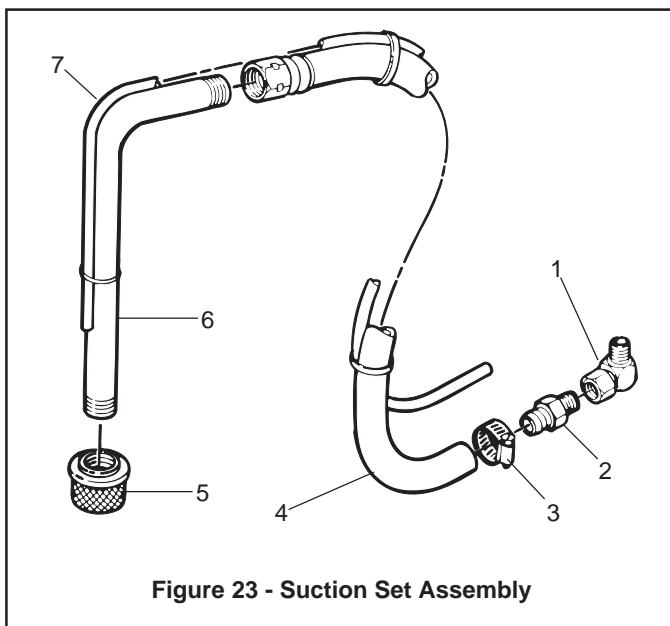
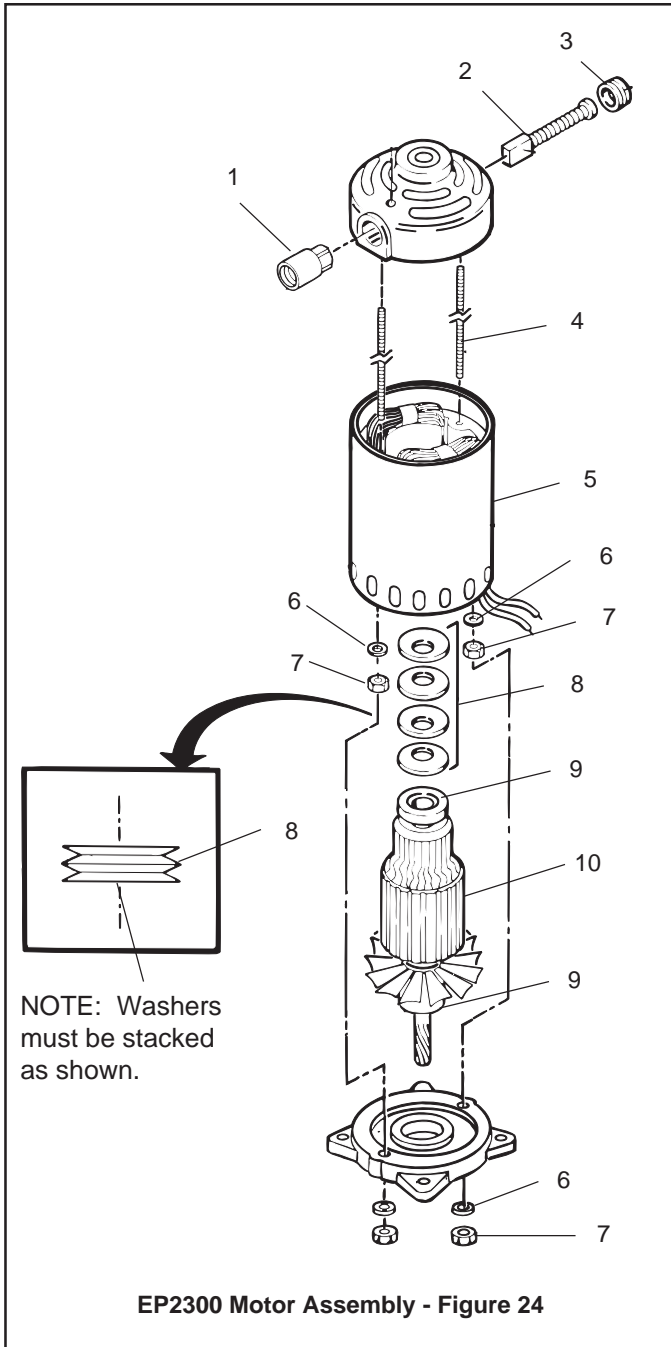

Figure 23 - Suction Set Assembly

## 0294185 SUCTION SET ASSEMBLY - FIGURE 23

ITEM	PART NO.	DESCRIPTION	QTY
1	0090447	Elbow	1
2	13455	Fitting, Hose	1
3	53635	Clamp, Hose	1
4	0294426	Hose, Siphon	1
5	02975	Strainer	1
6	13463	Tube, Siphon	1
7	0294424	Hose, Return	1

# EP2300 MOTOR ASSEMBLY - FIGURE 24



ITEM	PART NO.	DESCRIPTION	QTY.
1	01678	Brush Holder	2
2	01694	Motor Brush	2
3	01686	Brush Cap	2
4	01783	Stud	2
5	19498	Stator Assy.	1
6	50148	#10 Lockwasher	4
7	50865	10-32 Nut	4
8	01791	Belleville Washer	4
9	50962	Bearing-Commutator End	2
10	*01961	Armature w/Bearings	1

\* Includes #50962 Bearing

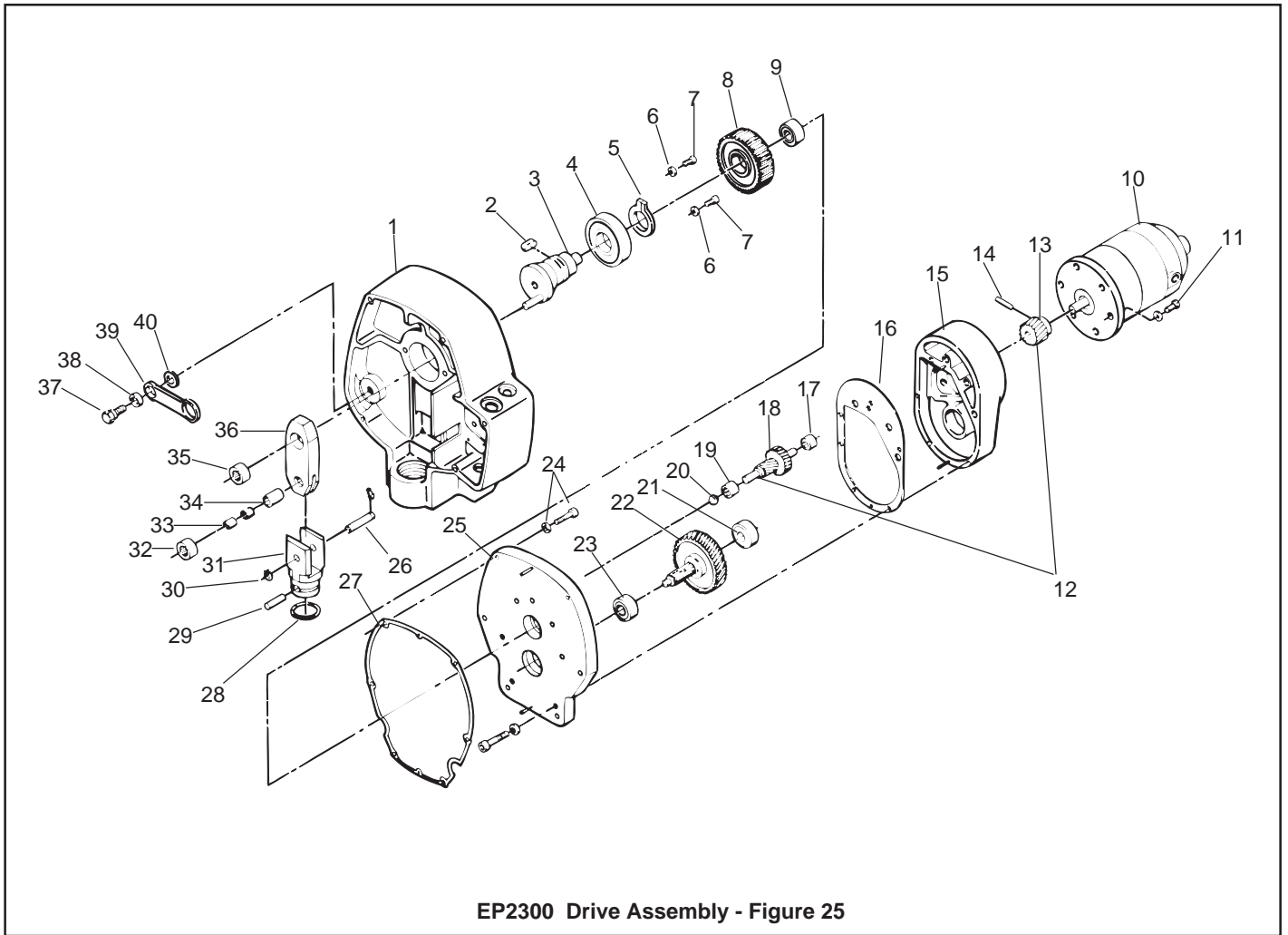

EP2300 Drive Assembly - Figure 25

## EP2300 DRIVE ASSEMBLY - FIGURE 25

ITEM	PART NO.	DESCRIPTION	QTY.	ITEM	PART NO.	DESCRIPTION	QTY.
1	0294349	Housing	1	21	50962	Bearing	1
2	05304	Key	1	22	05274	Low Speed Cluster	1
3	11177	Crankshaft	1	23	50954	Bearing	1
4	51837	Bearing	1	24	53074	Screw	6
5	51845	Ring, Retainer	1			Washer, Lock	6
6	11843	Washer	2	25	0294402	Plate, Adapter	1
7	53074	Screw	2	26	0294365	Pin, Yoke	1
8	05282	Gear	1	27	0294394	Gasket	1
9	50547	Bearing	1	28	0294301	Retainer. Spring	1
10	0294154	Motor with Pinion	1	29	0294302	Pin, Connecting	1
11	50318	Screw	13	30	51187	Ring, Retainer	2
	50113	Washer	13	31	0294606	Yoke	1
12	05208	Gear Set	1	32	0294366	Bearing	1
13	05207	Pinion	1	33	0294367	Bearing	2
14	50717	Spring Pin	1	34	0294364	Bushing	1
15	19015	Gear Case	1	35	50555	Bearing	1
16	17183	Gasket	1	36	0294604	Rod, Connecting	1
17	50989	Bearing	1	37	0294410	Bolt, Shoulder	1
18	05223	High Speed Cluster	1	38	0294368	Bearing	1
19	50997	Bearing	1	39	0294602	Drag Line	1
20	50008	Ball, Stainless	1	40	0294446	Washer	1

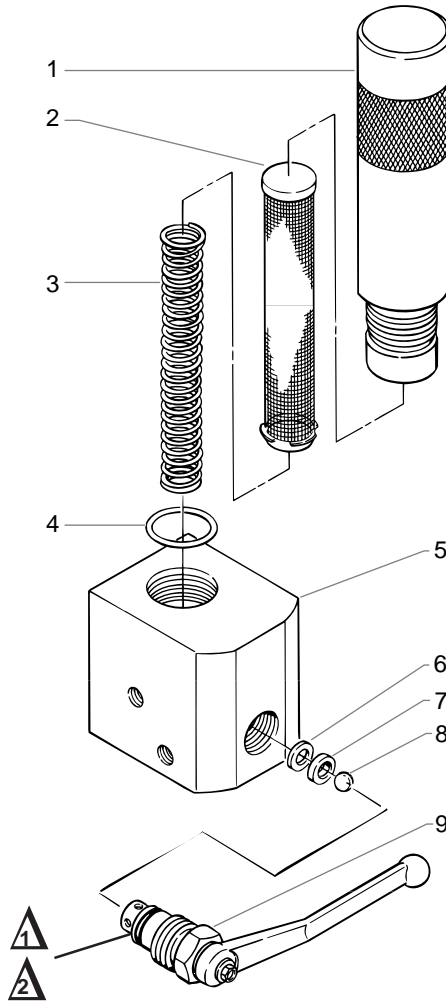

Figure 26 - Dump Valve Assembly

## 0294220 DUMP VALVE ASSEMBLY - FIGURE 26

ITEM	PART NO.	DESCRIPTION	QTY.	ITEM	PART NO.	DESCRIPTION	QTY.
1	0294194	Filter Body Assembly	1	5	0294555	Head, Filter/Dump Valve	1
2	14069	Filter Sieve (50 Mesh)	1	6	0294499	Seal, Dump Valve	1
	14068	Filter Sieve (100 Mesh) (OPTIONAL)		7	0294516	Seat, Valve	1
3	9894245	Support, Filter	1	8	9841502	Ball, 10mm	1
4	14072	O-Ring	1	9	0294214	Dump Valve Cartridge	1

### NOTES:

1 Apply antisieze (P/N 0093930) to threads when reassembled.

2 Torque to 35 Ft./Lbs. **CAUTION: Be sure the handle is turned all the way counterclockwise when reassembled. Valve seat (item 6) will be damaged if it is not.**

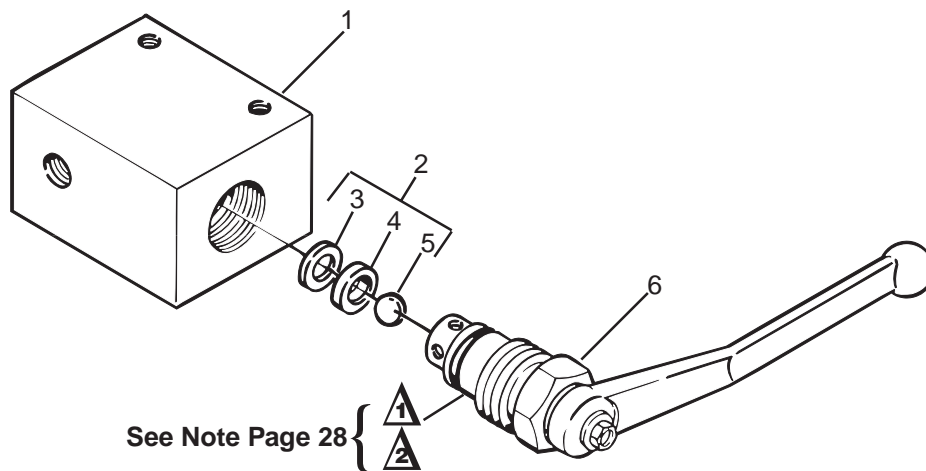

Figure 27 - Dump Valve Assembly

## DUMP VALVE ASSEMBLY - FIGURE 27

Item	Part No.	Description	Qty.	Item	Part No.	Description	Qty.
1	0294502	Housing, Dump Valve	1	4	0294516	Seat, Valve	1
2	0294966	Repair Kit	1	5	9841502	Ball, 10mm	1
3	0294499	Seal, Dump Valve	1	6	0294214	Dump Valve Cartridge	1

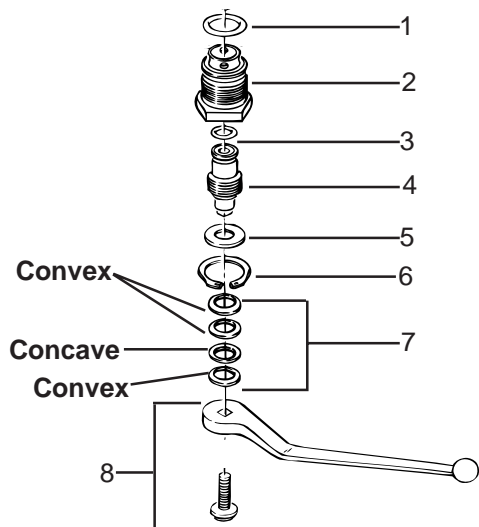

Figure 28 - Dump Valve Cartridge

## DUMP VALVE CARTRIDGE - FIGURE 28

Item	Part No.	Description	Qty.	Item	Part No.	Description	Qty.
1	9871046	O-Ring	1	5	0294501	Washer, Dump Valve	1
2	0294498	Body, Dump Valve	1	6	9822516	Ring, Retainer	1
3	9871045	O-Ring	1	7	0294788	Washer, Kit, Bellville	4
4	0294500	Stem, Dump Valve	1	8	0291512	Handle, Dump Valve	1

# ACCESSORIES

## GUN FILTERS

### Part Number Description

0153— Tungsten Carbide Flat Tips  
 0153003 Tip Guard, Flat Tip  
 0291004 Hose, Whip End, 3' x 3/16"  
 0291003 Hose, Whip End, 5' x 3/16"  
 0291002 Hose, Wireless, 25' x 1/4"  
 0291000 Hose, Wireless, 50' x 1/4"  
 0093896 Hose Connector, 1/4" x 1/4"M  
 0088154 Pressure Gauge  
 0153043 Tip Extension, 6" (fits 11/16" diffuser)  
 0153042 Tip Extension, 12" (fits 11/16" diffuser)  
 0152001 Power Roller Gun Attachment  
 0152308 9" Roller Cover, 3/8" Nap  
 0152307 9" Roller Cover, 1/2" Nap  
 0152309 9" Roller Cover, 3/4" Nap  
 0152310 9" Roller Cover, 1-1/4" Nap  
 0152235 12" Roller Cover, 1/2" Nap  
 0152236 12" Roller Cover, 3/8" Nap  
 0152237 12" Roller Cover, 3/4" Nap  
 0152238 12" Roller Cover, 1-1/4" Nap  
 0152700 Adapter, Power Roller Extension  
 0149017 G-10 Four Finger Airless Spray Gun (no tip)  
 0093930 Anti-Seize Compound  
 0152909 R-10 Telescoping Roller, 9", 3/8" Nap  
 0152900 R-10 Telescoping 12" Roller, 3/8" Nap  
 0502007 G-10 Four Finger Airless Spray Gun with 517 Reversible Tip  
 0502008 G-10 Two Finger Airless Spray Gun (no tip)  
 0502009 G-10 Two Finger Airless Spray Gun with 517 Reversible Tip  
 0270214 G-10 Four Finger Spray Pack with 50' x 1/4" airless hose  
 0502012 G-10 Two Finger Spray Pack with 50' x 1/4" Airless Hose

Part No.	Application	Filter Type	Mesh Number	Color of Filter Body
0089960	Synthetic resin enamels, clean varnishes, stains azures	Extrafine	0.084 mm	Red
0089959	Base coat enamels primer enamels fillers, marking paints, textured enamels	Fine	0.140 mm	Yellow
0089958	Emulsions Latex-paints acrylic-paints	Medium	0.315 mm	Green
0089957	Filler paints, large area surfaces	Coarse	0.560 mm	White



# Limited Warranty

## Commercial Airless Spray Equipment

### Two Year Warranty

Spray Tech, a division of Wagner Spray Tech Corporation ("Spray Tech"), warrants this product against defects in material and workmanship for a period of two years following the date of purchase by the original purchaser. During that period, Spray Tech will repair or replace any defective or worn-out component or, at Spray Tech's option, refund to the original purchaser the full purchase price for the product in exchange for the return of that product. However, Spray Tech will not replace or repair any fluid pump component on account of wear more than twice during the two year warranty period. This warranty does not cover consumable products such as filters and tips.

### Lifetime Warranty on Gear Trains, Electric Motors, and Gas Engines

Spray Tech warrants any gear train, electric motor (excluding brushes) and gas engine (excluding the clutch) in this product against defects in material and workmanship for the lifetime of the original purchaser. If Spray Tech determines that the foregoing warranty has been breached, Spray Tech will repair or replace the defective components without charge or, at Spray Tech's option, refund to the original purchaser the full purchase price for the product in exchange for the return of that product.

### Warranty Claims

Any request for repair or replacement pursuant to the warranties above must be accompanied by the return of the applicable parts, with transportation charges prepaid, to a service center authorized by Spray Tech or to Wagner Spray Tech Corporation, 1770 Fernbrook Lane, Minneapolis, MN 55447.

### Limitation of Remedies

THE REMEDIES SET FORTH ABOVE ARE THE EXCLUSIVE REMEDIES AVAILABLE FOR BREACH OF EXPRESS AND IMPLIED WARRANTIES. These remedies shall not be deemed to have failed of their essential purpose so long as Spray Tech is willing to repair or replace parts, or to refund the purchase price, as set forth above.

### What Is Not Covered By This Warranty

This warranty does not cover defects or damages caused by:

- the use or installation of repair or replacement parts or accessories not manufactured by Spray Tech;
- repair performed by anyone other than a Spray Tech Authorized Service Center; or
- abuse, misuse, negligence, accident, faulty installation or tampering in a manner which impairs normal operation.

This warranty also does not cover equipment and accessories supplied to Spray Tech from an original equipment manufacturer, including but not limited to hoses, tips, and accessories. Spray Tech will provide the purchaser with copies of the original equipment manufacturer's express warranties provided to Spray Tech along with the name and address of the appropriate manufacturer.

### Limitation of Remedies

IN NO CASE SHALL SPRAY TECH BE LIABLE FOR ANY INCIDENTAL, SPECIAL OR CONSEQUENTIAL DAMAGES OR LOSS, INCLUDING TRANSPORTATION COSTS, WHETHER SUCH DAMAGES ARE BASED UPON A BREACH OF EXPRESS OR IMPLIED WARRANTIES, BREACH OF CONTRACT, NEGLIGENCE, STRICT TORT, OR ANY OTHER LEGAL THEORY.

### Disclaimer Of Implied Warranties

THE FOREGOING WARRANTIES ARE IN LIEU OF ALL OTHER WARRANTIES, EXPRESS OR IMPLIED, INCLUDING BUT NOT LIMITED TO THE IMPLIED WARRANTIES OF MERCHANTABILITY AND FITNESS FOR A PARTICULAR PURPOSE.

### No Ability To Transfer

This warranty is extended to the original purchaser only and is not transferable.

## Patents

These products are covered by one or more of the following patents:

5,228,842	5,192,425	D344,832	5,318,314	5,282,722	5,099,183
5,346,037	5,494,199	5,472,318	5,435,697	4,992,633	

**SprayTECH.**

1770 Fernbrook Lane  
Minneapolis, Minnesota 55447  
Telephone 1-800-292-4637

Printed in U.S.A.

## Free Manuals Download Website

<http://myh66.com>

<http://usermanuals.us>

<http://www.somanuals.com>

<http://www.4manuals.cc>

<http://www.manual-lib.com>

<http://www.404manual.com>

<http://www.luxmanual.com>

<http://aubethermostatmanual.com>

Golf course search by state

<http://golfingnear.com>

Email search by domain

<http://emailbydomain.com>

Auto manuals search

<http://auto.somanuals.com>

TV manuals search

<http://tv.somanuals.com>