

Betriebsanleitung  
Operating manual .....p. 24  
Mode d'emploi .....p. 48  
Istruzioni per l'uso .....p. 71

---

**Airless Hochdruck-Spritzgerät**  
**Airless high-pressure spraying unit**  
**Groupe de projection à haute pression**  
**Impianto per la verniciatura a spruzzo ad alta pressione Airless**

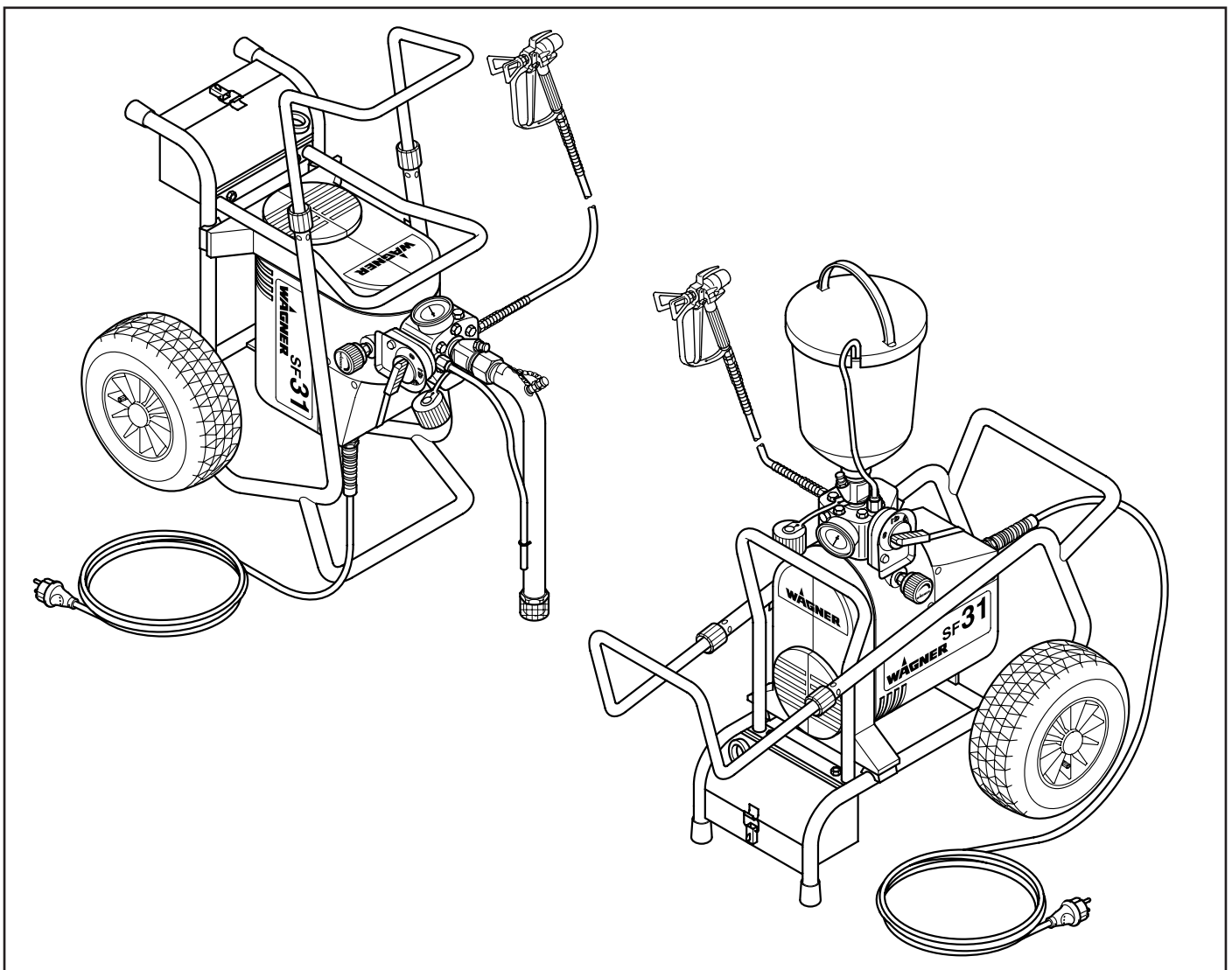

**Super Finish 27 • 31**

# Warning!

**Attention: Danger of injury by injection!**  
Airless units develop extremely high spraying pressures.



**Danger**

**1**

Never put your fingers, hands or any other parts of the body into the spray jet!  
Never point the spray gun at yourself, other persons or animals.  
Never use the spray gun without safety guard.

Do not treat a spraying injury as a harmless cut. In case of injury to the skin through coating materials or solvents, consult a doctor immediately for quick and expert treatment. Inform the doctor about the coating material or solvent used.

**2**

The operating instructions state that the following points must always be observed before starting up:

1. Faulty units must not be used.
2. Secure WAGNER spray gun using the safety catch on the trigger.
3. Ensure that the unit is properly earthed. The connection must take place through a correctly earthed two-pole and earth socket outlet.
4. Check allowable operating pressure of high-pressure hose and spray gun.
5. Check all connections for leaks.

**3**

The instructions regarding regular cleaning and maintenance of the unit must be strictly observed.

Before any work is done on the unit or for every break in work the following rules must be observed:

1. Release the pressure from spray gun and hose.
2. Secure the WAGNER spray gun using the safety catch on the trigger.
3. Switch off unit.

# Be safety-conscious!

# Contents

<b>1. SAFETY REGULATIONS FOR AIRLESS SPRAYING</b>	<b>26/27</b>	11.4 Pressure regulating valve	18
<b>2. GENERAL VIEW OF APPLICATION</b>	<b>27/28</b>	11.5 Relief valve	38
2.1 Application	27	11.6 Exchanging diaphragm	39
2.2 Coating materials	27	11.7 Replace unit connection line	39
<b>3. DESCRIPTION OF UNIT</b>	<b>28-30</b>	11.8 Circuit diagram	40
3.1 Airless process	28	<b>12. ACCESSORIES AND SPARE PARTS</b>	<b>41-44</b>
3.2 Functioning of the unit	28	12.1 Accessories for Super Finish 27 and 31	41
3.3 Explanatory diagram	29	Accessories illustration for Super Finish 27 and 31	42
– Vertical set-up with suction system		Accessories illustration for Super Finish 27 and 31	95
– Horizontal set-up with upper hopper		12.2 Spare parts list pump head Super Finish 27 and 31	43
3.4 Technical data Super Finish 27 and 31	30	Spare parts diagram pump head	
3.5 Transport	30	Super Finish 27 and 31	96
<b>4. STARTING OPERATION</b>	<b>30-32</b>	12.3 Spare parts list trolley	43
4.1 Unit with suction system	30	Spare parts diagram trolley	97
4.2 Unit with upper hopper (5 litres)	30/31	12.4 Spare parts list suction system	43
4.3 High-pressure hose and spray gun	31	Spare parts diagram suction system	97
4.4 Connection to the mains	31	12.5 Spare parts list upper hopper 5 litres	43
4.5 Cleaning preserving agent when starting-up of operation initially	31	Spare parts diagram upper hopper 5 litres	97
4.6 Ventilate unit (hydraulic system) if the sound of the inlet valve is not audible	31/32	12.6 Spare parts list upper hopper 20 litres	43
4.7 Starting operation of unit with coating material	32	Spare parts diagram upper hopper 20 litres	97
4.8 Socket on unit	32	12.7 Spare parts list pump aggregate	
<b>5. SPRAYING TECHNIQUE</b>	<b>32</b>	Super Finish 27 and 31	44
<b>6. HANDLING THE HIGH-PRESSURE HOSE</b>	<b>32</b>	Spare parts diagram pump aggregate	
6.1 High-pressure hose	32	Super Finish 27 and 31	98
<b>7. INTERRUPTION OF WORK</b>	<b>32</b>	<b>13. APPENDIX</b>	<b>45-46</b>
<b>8. CLEANING UNIT (SHUTTING DOWN OPERATION)</b>	<b>33/34</b>	13.1 Selection of tip	45
8.1 Cleaning unit from outside	33	13.2 Servicing and cleaning of Airless hard-metal tips	45
8.2 Suction filter	34	13.3 Spray gun accessories	45
8.3 High-pressure filter (accessory)	34	13.4 Airless tip table	46
8.4 Cleaning Airless spray gun G 12	34	<b>IMPORTANT NOTES ON PRODUCT LIABILITY</b>	<b>101</b>
<b>9. REMEDY IN CASE OF DISTURBANCE</b>	<b>35/36</b>	<b>CE DECLARATION OF CONFORMITY</b>	<b>101</b>
<b>10. SERVICING</b>	<b>36</b>	<b>NOTE ON DISPOSAL</b>	<b>101</b>
10.1 General servicing	36	<b>WARRANTY</b>	<b>101/102</b>
10.2 High-pressure hose	36	<b>SALES AND SERVICE COMPANIES</b>	<b>109</b>
<b>11. REPAIRS ON THE UNIT</b>	<b>37-40</b>		
11.1 Inlet valve trigger with Super Finish 31	37		
11.2 Inlet valve	37		
11.3 Outlet valve	37		

# 1. SAFETY REGULATIONS FOR AIRLESS SPRAYING

All local regulations in force must be observed.  
For secure handling of Airless high-pressure spraying units the following safety regulations are to be observed:

## •Flash point



**Danger**

Only use coating materials with a flash point of 21 °C or above without additional heating. The flash point is the lowest temperature at which vapours develop from the coating material.

These vapours are sufficient to form an inflammable mixture over the air above the coating material.

## •Explosion protection



**Danger**

Do not use the unit in work places which are covered to the explosion protection regulations.

## •Danger of explosion and fire through sources of flame during spraying work



**Danger**

There may be no sources of flame such as, for example, open fires, smoking of cigarettes, cigars or tobacco pipes, sparks, glowing wires, hot surfaces, etc. in the vicinity.

## •Danger of injury through the spray jet



**Danger**



**Caution! Danger of injury through injection!**

Never point the spray gun at yourself, other persons or animals.

Never use the spray gun without spray jet safety guard. The spray jet may not come into contact with any part of the body.

In working with Airless spray guns, the high spray pressures arising can cause very dangerous injuries.

If contact is made with the spray jet, coating material can be injected into the skin. Do not treat a spray injury as a harmless cut. In the case of injury to the skin through coating material or solvents, consult a doctor for quick and correct treatment. Inform the doctor about the coating material or solvent used.

## •Secure spray gun against unintended operation

Always secure the spray gun when mounting or dismounting the tip and in case of interruption to work.

## •Recoil of spray gun



**Danger**

In case of high operating pressure, pulling the trigger guard can effect a recoil force of up to 15 N. If you are not prepared for this, your hand can be thrust backwards or your balance lost. This can lead to injury.

## •Respiratory protection for protection against vapours of solvents

Wear respiratory protection when spraying.  
The user must be provided with a breathing mask.

## •Prevention of occupational illnesses

Protective clothing, gloves and possibly skin protection cream are necessary for the protection of the skin. Observe the regulations of the manufacturer concerning coating materials, solvents and cleaning agents in preparation, processing and cleaning units.

## •Max. operating pressure

**Max. permissible operating pressure for spray gun, spray gun accessories and high-pressure hose may not fall short of the maximum operating pressure of 250 bar (25 MPa) stated on the unit.**

## •High-pressure hose (safety note)

Electrostatic charging of spray guns and the high-pressure hose is discharged through the high-pressure hose. For this reason the electric resistance between the connections of the high-pressure hose must be equal or lower than 1 MΩ.



**For reasons of function, safety and durability use only original WAGNER high-pressure hoses.**

## •Electrostatic charging (formation of sparks or flame)



**Danger**

Under certain circumstances, electrostatic charging can occur on the unit due to the rate of flow of the coating material when spraying. On discharging this can result in the emergence of sparks or fire. It is therefore necessary that the unit is always earthed through the electrical installation. The connection must take place through a correctly earthed two-pole-and-earth socket outlet.

## •Using unit on construction sites

**Connection to the mains only through a special feed point, e.g. through an error protection installation with INF ≤ 30 mA.**

## •Loading the socket at the unit

**Do not load the socket with more than 1000 Watt. Unroll any connected cable drum completely.**

### •Ventilation when spraying in rooms

Adequate ventilation must be guaranteed for the removal of the solvent vapours.

### •Suction installations

These are to be set-up by the user of the unit according to local regulations.

### •Earthing of the object

The object to be coated must be earthed.

### •Cleaning units with solvents



**Danger**

When cleaning the unit with solvents, the solvent should never be sprayed or pumped back into a container with a small opening (bunghole). An explosive gas/air mixture can be produced. The container must be earthed.

### •Cleaning the unit



**Danger**

**Danger of short circuit through penetrating water!**

**Never spray down the unit with high-pressure or high-pressure steam cleaners.**

**Socket on unit**

**Only carry out damp cleaning in the area of the socket and the multifunction switch when the mains plug is removed.**

### •Work or repairs on the electrical equipment

Only have this work carried out by a qualified electrician. No liability will be taken for incorrect installation.

### •Working on electrical components

**Remove the mains plug from the socket for all such works.**

### •Setting-up on uneven surfaces

The front side of the unit must point downwards to prevent sliding away. (fig. 1)

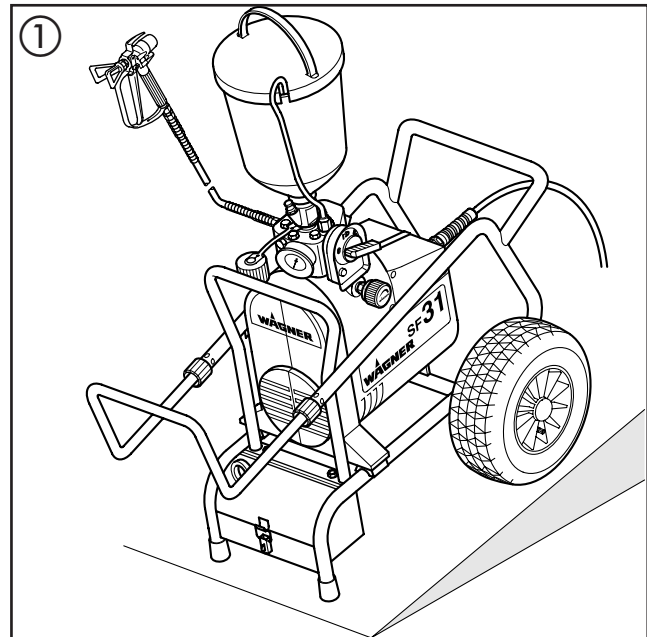

## 2. GENERAL VIEW OF APPLICATION

### 2.1 APPLICATION

All painting jobs in the workshop and on the building site, small and large-area dispersion work with the spray gun or internally fed Airless roller, corrosion and fire protection.

#### Examples of object of spraying

Doors, door frames, balustrades, furniture, wooden cladding, fences, radiators (heating) and steel parts, internal ceilings and walls, and also façades, basement garages, fire and noise protection for steel and wooden construction.

### 2.2 COATING MATERIALS

#### Processible coating materials



Pay attention to the Airless quality of the coating materials to be processed.

Dilutable lacquers and paints or those containing solvents, two-component coating materials, dispersions, latex paints, façade paints, roof and attic coatings, fire and corrosion protection material.

No other materials should be used for spraying without WAGNER's approval.

#### Filtering

In spite of the suction filter, the insertion filter in the spray gun and the high-pressure filter obtainable as accessory, filtering of the coating material is to be recommended in general. Stir coating material before commencement of work.



**Attention:** Make sure, when stirring up with motor-driven agitators that no air bubbles are stirred in. Air bubbles disturb when spraying and can, in fact, lead to interruption of operation.

### Viscosity

With this unit it is possible to process highly viscous coating materials of up to around 25.000 mPa·s.

If highly viscous coating materials cannot be taken in by suction, they must be diluted in accordance with the manufacturer's instructions.

### Two-component coating material

The appropriate processing time must be adhered to exactly. Within this time rinse through and clean the unit meticulously with the appropriate cleaning materials.

### Coating materials with sharp-edged additional materials

These have a strong wear and tear effect on valves, high-pressure hose, spray gun and tip. The durability of these parts can be reduced appreciably through this.

## 3. DESCRIPTION OF UNIT

### 3.1 AIRLESS PROCESS

The main areas of application are thick layers of highly viscous coating material for large areas and a high consumption of material.

A diaphragm pump takes in the coating material by suction and conveys it to the tip. Pressed through the tip at a pressure of up to a maximum of 250 bar (25 MPa), the coating material is atomised. This high pressure has the effect of micro fine atomisation of the coating material.

As no air is used in this process, it is described as an AIRLESS process.

This method of spraying has the advantages of finest atomisation, cloudless operation and a smooth, bubblefree surface. As well as these, the advantages of the speed of work and convenience must be mentioned.

### 3.2 FUNCTIONING OF THE UNIT

In the following there is a short description of the technical construction for better understanding of the function.

WAGNER Super Finish 27 and 31 are electrically driven high-pressure spraying units.

The electric motor (fig. 2, item 1) drives the pump by means of a toothed belt (2).

In the pump the diaphragm (3) is moved up and down by means of hydraulic oil.

The inlet valve is opened independently through the downward movement of the diaphragm.

The outlet valve is opened by means of the upward movement

of the diaphragm. The coating material flows under high pressure through the high-pressure hose to the spray gun. The coating material is atomised when flowing out of the tip.

The pressure regulating valve (4) controls the operating pressure and the quantity of the conveyed coating material.

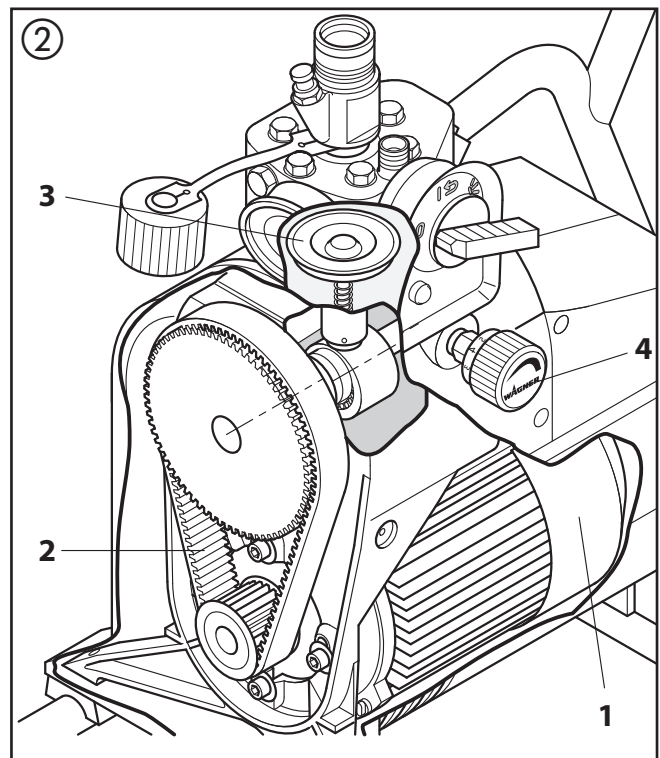

### 3.3 EXPLANATORY DIAGRAM

#### Vertical set-up with suction system

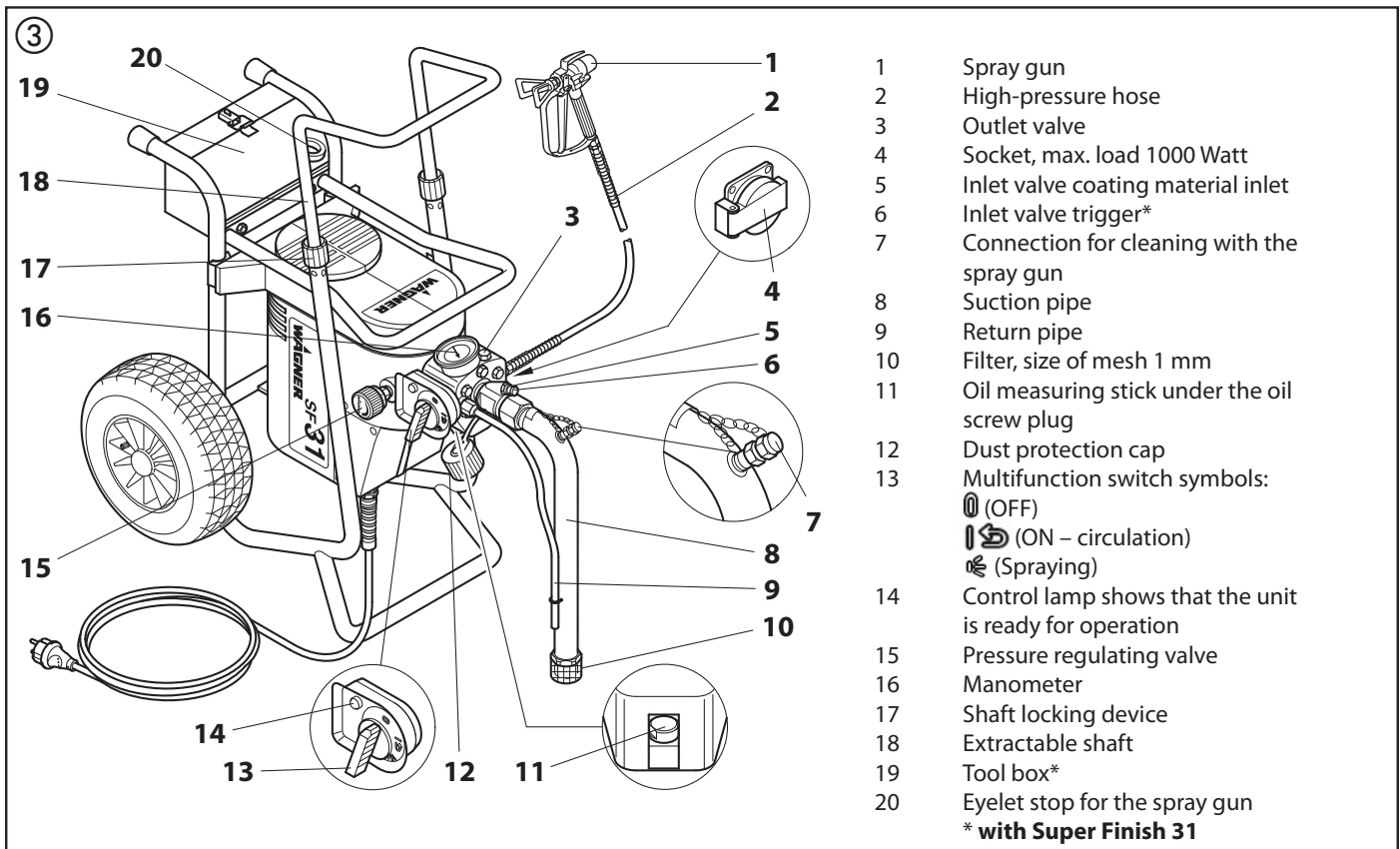

#### Horizontal set-up with upper hopper

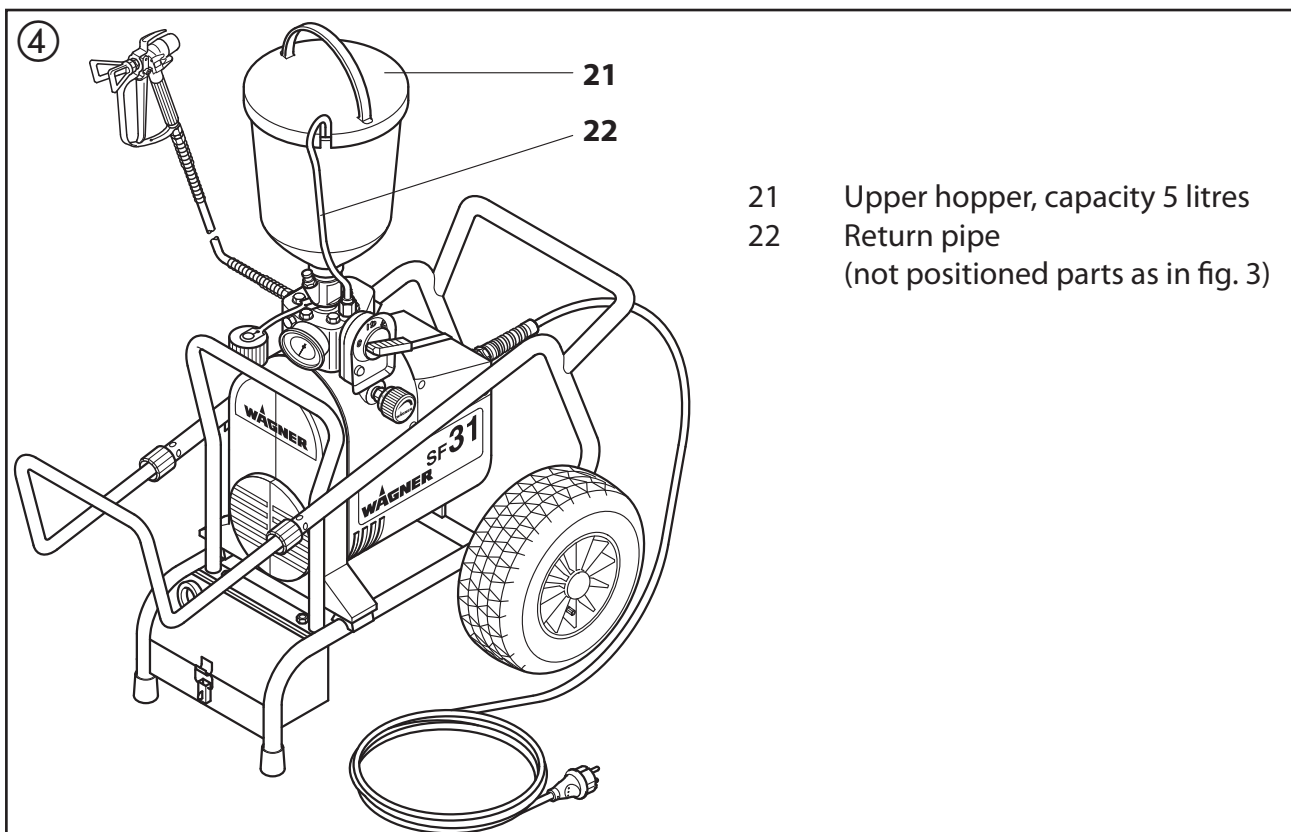

### 3.4 TECHNICAL DATA

	Super Finish 27	Super Finish 31
Voltage:	230 Volt~, 50 Hz	
Fuse protection:	16 A slow-blow	
Voltage on multifunction switch:	24 V	
Unit connection line:	6 m long, 3 x 1.5 mm <sup>2</sup>	
Socket on unit:	230 Volt ~, 50 Hz	
Max. connection:	1000 Watt	
Type of protection:	IP 44	IP 54
Capacity:	1.5 kW	1.7 kW
Max. operating pressure:	250 bar (25 MPa)	
Max. volume flow:	3.0 l/min 3.5 l/min (220 Volt~, 60 Hz)	3.5 l/min
Volume flow at 120 bar (12 MPa) with water:	2.5 l/min 3.1 l/min (220 Volt~, 60 Hz)	3.2 l/min
Max. size of tip:	0.027 inch – 0.69 mm	0.031 inch – 0.79 mm
Max. temperature of the coating material:	43°C	
Max. viscosity:	25.000 mPa·s	
Net weight:	40 kg	43 kg
Hydraulic filling quantity:	0.9 Litre, ESSO NUTO H 22	
Max. tyre pressure:	2 bar (0.2 MPa)	
Max. acoustic pressure level:	74 dB (A)*	

\*Place of measuring: 1 m in distance from the unit and 1.6 m above the floor, 120 bar (12 MPa) operating pressure, reverberant floor

### 3.5 TRANSPORT

Push or pull unit.  
Loosen terminal sleeves (fig. 5, item 1) on the shaft (↺ open).  
Extract shaft to the desired length.  
Tighten terminal sleeves again by hand (↻ closed).

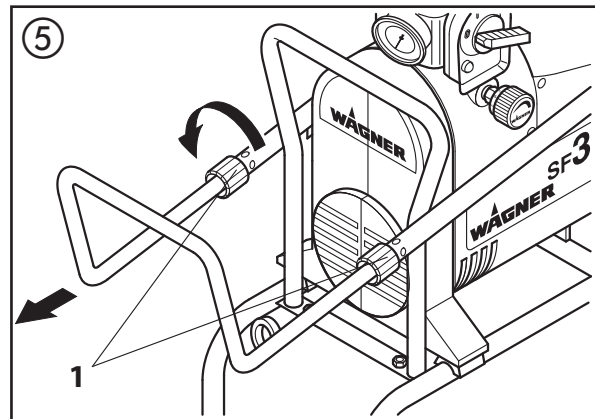

#### Transport in vehicle

Unroll high-pressure hose and lay it over the shaft. Secure the unit by means of suitable fastening.

## 4. STARTING OPERATION

### 4.1 UNIT WITH SUCTION SYSTEM

1. Screw off dust protection cap (fig. 6, item 1).
2. Pay attention to clean sealing areas on the connections. Pay attention to the fact that the red inlet (2) is inserted into the coating material inlet.
3. Screw and tighten the union nut (3) on the suction pipe (4) onto the coating material inlet (5) with the accompanying spanner 41 mm.
4. Screw the union nut (6) on the return pipe (7) onto the connection (8).

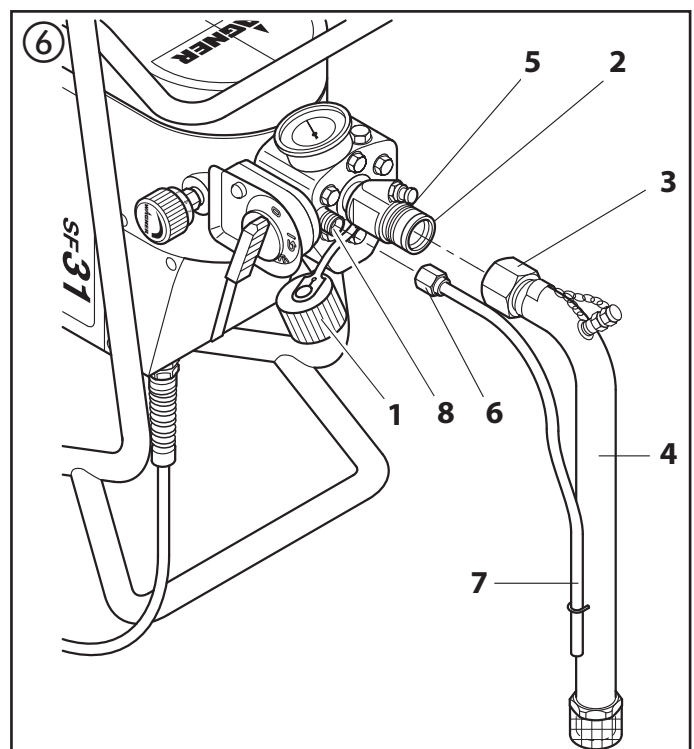

### 4.2 UNIT WITH UPPER HOPPER (5 LITRES)

1. Screw off dust protection cap (fig. 7, item 1).
2. Pay attention to clean sealing areas on the connections.



Pay attention to the fact that the red inlet (2) is inserted into the coating material inlet.

- Screw the upper hopper (3) onto the coating material inlet (4).
- Hang the return pipe (5) into the upper hopper.
- Screw the union nut (6) on the return pipe (5) onto the connection (7).

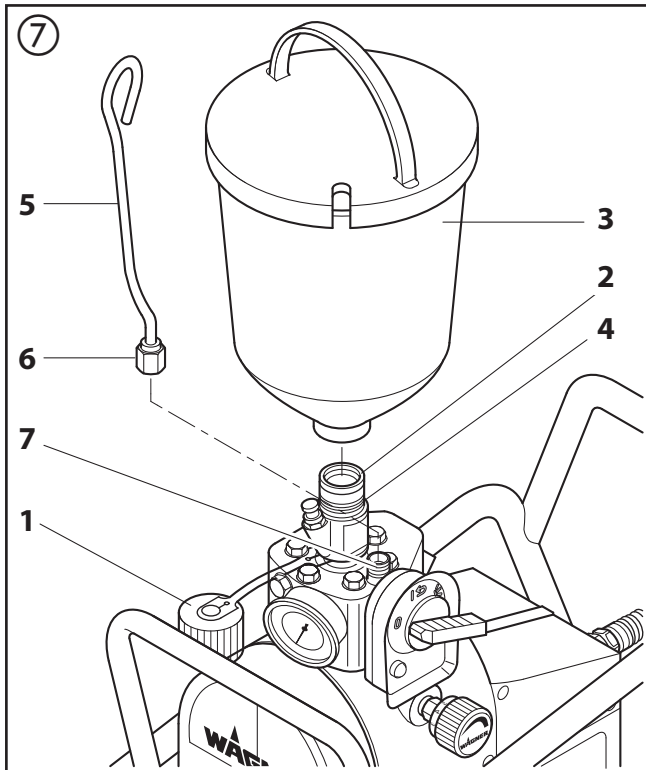

#### 4.3 HIGH-PRESSURE HOSE AND SPRAY GUN

- Screw the high-pressure hose (fig. 8, item 1) onto the hose connection (2).
- Screw the spray gun (3) with selected tip onto the high-pressure hose.
- Tighten the union nut on high-pressure hose so that no coating material escapes.

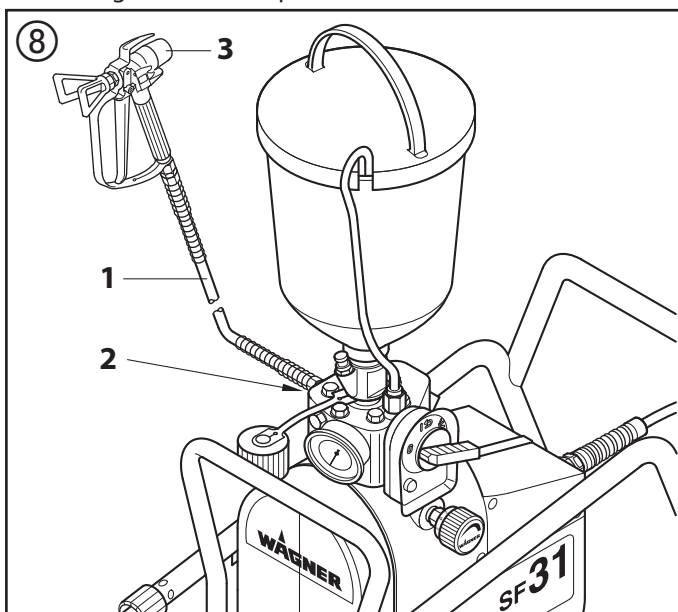

#### 4.4 CONNECTION TO THE MAINS



The connection must take place through a correctly earthed two-pole and-earth socket outlet.

Before connection to the mains, pay attention to the fact that the mains voltage agrees with the information on the makers' name plate on the rear of the unit.

The green control lamp will light up as soon as the mains plug has been connected.



#### 4.5 CLEANING PRESERVING AGENT WHEN STARTING-UP OF OPERATION INITIALLY

##### 1. Unit with suction system

Submerge suction pipe into a vessel filled with a suitable cleaning agent

##### 2. Unit with upper hopper

Fill suitable cleaning agent into the upper hopper.

- Set multifunction switch (fig. 9, item 1) to  (ON-circulation); the unit commences to run. Turn pressure regulation knob (2) to the **right** until stop.
- Wait until the cleaning agent flows out at the re-turn pipe.
- Set multifunction switch (1) to  (spray). Pull trigger guard of spray gun.
- Spray cleaning agent from the unit into an open collection container.

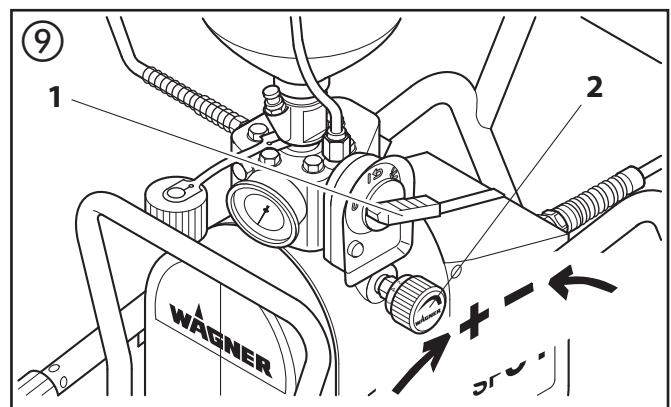

#### 4.6 VENTILATE UNIT (HYDRAULIC SYSTEM) IF THE SOUND OF THE INLET VALVE IS NOT AUDIBLE

- Turn pressure regulating knob (fig. 10, item 1) **three revolutions** to the **left**.
- Set multifunction switch (2) to  (ON - circulation). The hydraulic system is ventilated. Leave the unit on for two to three minutes.
- Then turn the pressure regulating knob (1) to the **right** until stop. Sound of the inlet valve is audible.
- If not, repeat points 1 and 3.

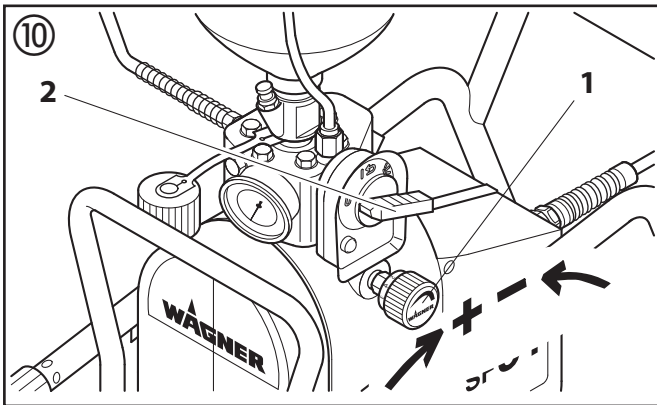

#### 4.7 STARTING OPERATION OF UNIT WITH COATING MATERIAL

##### 1. Super Finish 27



Before mounting suction system or upper hopper, check inlet valve for functionality. Press inlet valve with a soft implement (e.g. a pencil); it must allow movement.

##### 2. Unit with suction system

Submerge suction pipe into a container filled with coating material.

##### 3. Unit with upper hopper

Fill coating material into the upper hopper.

##### 4. Super Finish 31

Press inlet valve trigger (fig 11, item 1) several times to release possibly clogged inlet valve.

5. Set multifunction switch (2) to  (ON - circulation); the unit will start. Turn pressure regulating knob (3) to the **right** until stop.

6. When the sound of the valves can be heard clearly, the unit is ventilated.

7. Set multifunction switch (2) to  (spray). Pull trigger guard of spray gun, then set the desired operating pressure by means of the pressure regulating knob (3).

8. The unit is ready for spraying.

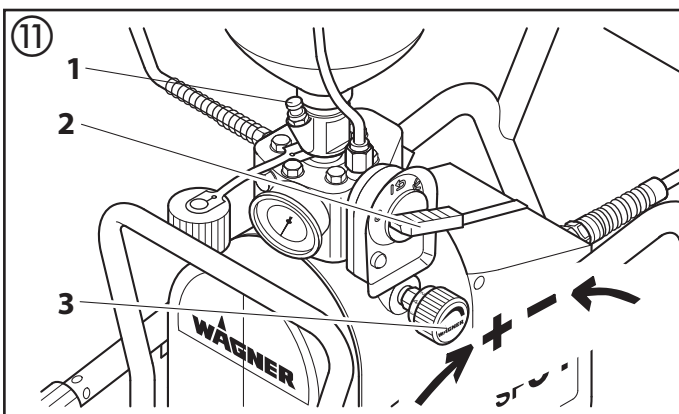

#### 4.8 SOCKET ON UNIT

It is possible, for example, to connect an agitator, a working lamp etc with a **maximum of 1000 Watt**.



Completely unroll a connected cabledrum.



So that in switching on the unit the mains fuse protection of 16 A does not react: Always switch on the Super Finish 27 or 31 unit first and then the connected unit.

## 5. SPRAYING TECHNIQUE

Guide the spray gun evenly during the spraying process. If this is not observed, an irregular spraying appearance will be the result. Spray with the arm and not with the wrist. Maintain a parallel distance of approx. 30 cm, between the spray gun and object of spraying. The lateral limitation of the spray jet should not be too distinct. The edge of the spraying should be gradual to facilitate overlapping of the next coat. Always guide the spray gun parallel to and at an angle of 90° to the spraying area; in this way the least paint cloud arises.



If very distinct edge zones appear and streaks in the spray jet – increase operating pressure or dilute coating material.

## 6. HANDLING THE HIGH-PRESSURE HOSE

Avoid bending or folding the high-pressure hose sharply; smallest bending radius approx. 10 cm.

Do not run over the high-pressure hose and protect it from sharp objects and edges.



There is danger of injury as a result of a leaking high-pressure hose. Replace high-pressure hose immediately. Never repair the high-pressure hose your-self!



### 6.1 HIGH-PRESSURE HOSE

The unit is equipped with high-pressure hose specially suited for diaphragm pumps.



For reasons of function, safety and durability, only use original WAGNER high-pressure hoses.

## 7. INTERRUPTION OF WORK

1. Switch off unit, set multifunction switch to  (pressure relief, circulation), then to  (OFF).
2. Secure spray gun, see operating manual for spray gun.
3. If the tip is to be cleaned, see page 45, point 13.2.

4. **Unit with suction system**

Leave the suction system submerged in the coating material or submerge it into the appropriate cleaning agent. Suction filter and unit should not dry out.

	In using quick-drying - or two-component coating material, do not fail to rinse unit through with a suitable cleaning agent during the processing period.
---	---

	<b>The effect of cleaning is increased if the spray gun is alternately opened and closed.</b>
---	---



	<b>In case of coating materials diluted with water, warm water improves cleaning.</b>
---	---

## 8. CLEANING UNIT (SHUTTING DOWN OPERATION)

Cleanliness is the surest guarantee for disturbance-free operation. Always clean the unit after completing spraying work. In no event may residue of the coating material dry and collect in the unit. The cleaning agent used for cleaning (only with a flash point of over 21 °C) must correspond to the coating material.

•**Secure spray gun**, see operating manual for spray gun. Dismount tip and clean, see page 45, point 13.2.

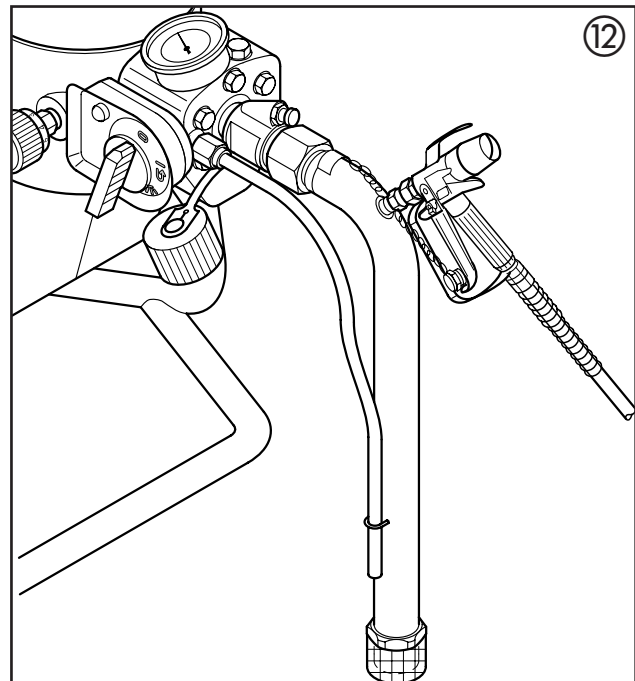

•**Unit with suction system (fig. 12)**

1. Remove suction system from the material vessel, e.g. put unit in the horizontal set-up position.
2. Switch on unit, set multifunction switch to  (ON-circulation) and further to  (spray).
3. Pull the trigger guard on the spray gun in order to pump residue coating material from the suction pipe, the high-pressure hose and the spray gun into an open container.





	In case of coating material containing solvents, the vessel must be earthed.
---	--





• **Unit with upper hopper**

1. Fill upper hopper with suitable cleaning agent.
2. Switch on unit, set multifunction switch to  (ON - circulation).
3. Operate unit for a few minutes in circuit with spray gun closed (without tip).
4. Set multifunction switch to  (spray).
5. Pull trigger guard on spray gun.
6. Pump cleaning agent into a separate, open container until the unit is empty.

	<b>Caution! Do not pump or spray in container with a small opening (bunghole)! See safety regulations.</b>
---	--

	In the case of coating materials containing solvents, the container must be earthed.
---	--

	<b>Caution! Do not pump or spray in container with a small opening (bunghole)! See safety regulations.</b>
---	--

4. Submerge suction system in a suitable cleaning agent.
5. Set multifunction switch to  (OFF).
6. Screw on spray gun on suction pipe (fig. 12) with the two accompanying spanners 22 mm.
7. Set multifunction switch to  (ON - circulation).
8. Pump suitable cleaning agent in the circuit for approx. 1 minute.
9. Pull trigger guard on spray gun and hold with clamp.
10. Set multifunction switch to  (spray).
11. Clean suction pipe for about three minutes.
12. Rinse in circuit - set multifunction switch to  (ON).
13. Close spray gun.
14. When cleaning with water, repeat procedure for about three minutes with clear water.
15. Switch off unit - set multifunction switch to  (OFF).

7. Switch off unit, set multifunction switch to  (OFF).

### 8.1 CLEANING UNIT FROM OUTSIDE

	<b>First of all pull out mains plug from socket.</b>
---	--



**Danger**

**Danger of short circuit through penetrating water! Never spray down the unit with high-pressure or high-pressure steam cleaners.**

Wipe down unit externally with a cloth which has been immersed in a suitable cleaning agent.  
Clean socket and the multifunction switch areas meticulously also.

### 8.2 SUCTION FILTER



Clean filters also guarantee the maximum conveyance quantity, constant spraying pressure and faultless function of the unit.

#### •Unit with suction system

1. Screw off the filter (fig. 13) from suction pipe.
2. Clean or replace the filter. Carry out cleaning with a hard brush and an appropriate cleaning agent.

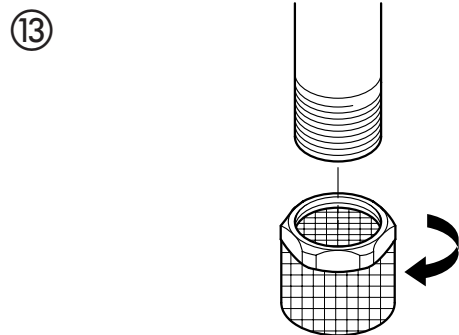

#### •Unit with upper hopper

1. Release screws with a screwdriver (fig. 14, item 1).
2. Lift (2) and remove filter disk with a screwdriver.
3. Clean or replace the filter disk. Carry out cleaning with a hard brush and an appropriate cleaning agent.

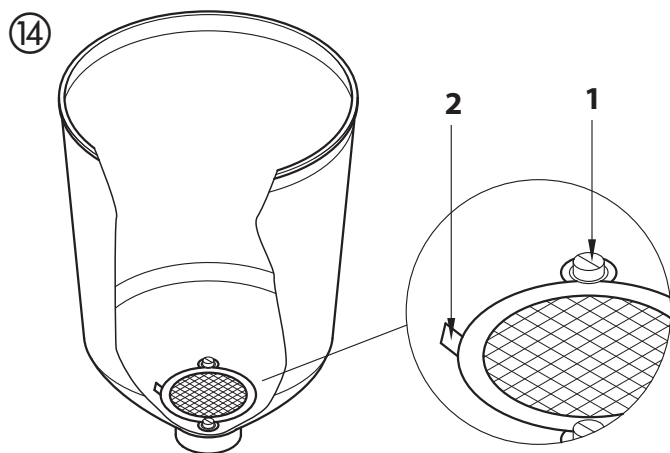

### 8.3 HIGH-PRESSURE FILTER (ACCESSORY)

- Switch off unit – set multifunction switch to 0 (OFF).
- Open high-pressure filter and clean filter insert; in addition:
  1. Insert open-ended spanner into the groove of the filter housing (fig. 15, item 1) – screw out filter housing.
  2. Remove filter housing (1), supporting part (2), centring ring

- (4) and O-ring (5).
3. Roll in filter insert (3) (for filter insert with 70 mesh this is not necessary) and pull out of supporting part (2).
4. Clean all parts with appropriate cleaning agent. If pressure air is existent – blow through filter insert and supporting part.
5. Remount high-pressure filter.

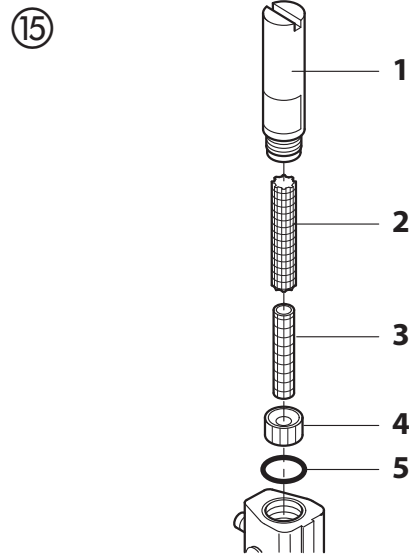

### 8.4 CLEANING AIRLESS SPRAY GUN G 12

- Rinse Airless spray gun with an appropriate cleaning agent.
- Clean tip thoroughly with appropriate cleaning agent so that no coating material residue re-mains.
- Thoroughly clean the outside of the Airless spray gun.

#### Intake filter in Airless spray gun

##### Dismounting (fig. 16)





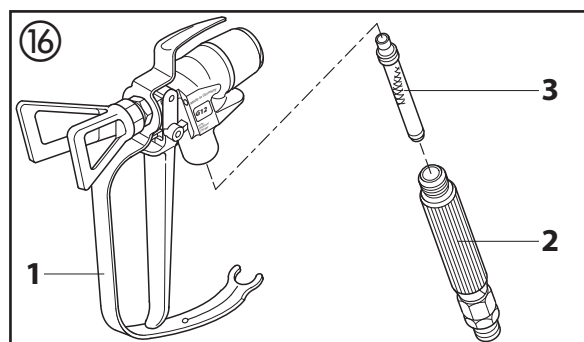

1. Pull protective guard (1) forward vigorously.
2. Screw grip (2) out of the gun housing. Remove intake filter (3).
3. Intake filter congested or defective – replace.

##### Mounting

1. Place intake filter (3) with the long cone into the gun housing.
2. Screw in grip (2) into the gun housing and tighten.
3. Slot in protective guard (1).

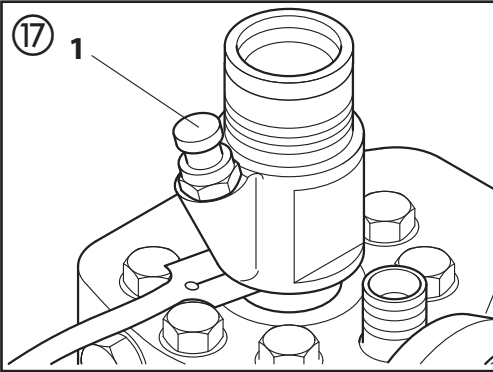

## 9. REMEDY IN CASE OF DISTURBANCE

Type of malfunction	Possible cause	Measure for elimination of malfunction
<p><b>Unit does not start</b></p>	<ul style="list-style-type: none"> <li>• No voltage.</li> <li>• Fuse protection has reacted. For example an agitator is connected to the socket on the unit. This agitator has not been switched off before switching on the unit Super Finish 27 or 31.</li> <li>• The unit switches off automatically in case of overloading. The green control lamp in the multifunction switch extinguishes.</li> </ul> <p><b>The unit does not switch on again independently.</b></p>	<ul style="list-style-type: none"> <li>• Check voltage supply</li> <li>• First switch on the unit Super finish 27 or 31 and then, for example, the connected agitator.</li> <li>• The green control light will light up again after 2 - 3 minutes. Then set multifunction switch to  (OFF).</li> </ul> <p>Switch unit on again  (ON – circulation), then set multifunction switch to  (spray).</p>
<p><b>Unit does not exert suction</b></p>	<p><b>Unit with suction system:</b></p> <ul style="list-style-type: none"> <li>• Filter extends beyond the liquid level and sucks in air.</li> <li>• Suction filter congested.</li> <li>• Suction pipe not tightened, i.e. the unit sucks in ancillary air.</li> </ul> <p><b>Device with upper hopper:</b></p> <ul style="list-style-type: none"> <li>• Filter disk congested.</li> </ul> <p><b>Super Finish 31:</b></p> <ul style="list-style-type: none"> <li>• Inlet valve trigger leaks, sucks in ancillary air.</li> </ul> <p><b>Super Finish 27:</b></p> <ul style="list-style-type: none"> <li>• Inlet valve is clogged, cannot be pressed down into inlet valve housing.</li> </ul> <p><b>Super Finish 31:</b></p> <ul style="list-style-type: none"> <li>• Inlet valve is clogged</li> </ul>	<ul style="list-style-type: none"> <li>• Refill coating material.</li> <li>• Clean or replace suction filter.</li> <li>• Clean and tighten connections.</li> <li>• Clean or replace filter disk.</li> <li>• Replace stripper and O-ring, see page 37, point 11.1.</li> </ul> <p>Switch off unit -  (OFF)</p> <ul style="list-style-type: none"> <li>• Inlet valve must allow movement; test by pressing the inlet valve slightly with a soft implement (e.g. a pencil). Moving the inlet valve back and forth removes impurities from the valve seat. If this does not help, screw the inlet valve out of the paint section and clean it, refer to page 37, point 11.2.</li> </ul> <p>Switch off unit -  (OFF)</p> <ul style="list-style-type: none"> <li>• Press inlet valve trigger (fig. 17, item 1) several times; this releases the clogged inlet valve.</li> </ul> <div data-bbox="997 1534 1492 1904">  </div> <div data-bbox="997 1937 1492 2072">  <p><b>Attention</b></p> <p><b>Press inlet valve trigger (fig.17, item 1) only by hand -never hit the inlet valve trigger with a hammer.</b></p> </div>

Type of malfunction	Possible cause	Measure for elimination of malfunction
<b>Unit does not exert suction</b>	<ul style="list-style-type: none"> <li>• Inlet valve does not close as, for example, the guidance is clogged</li> <li>• Outlet valve is clogged</li> </ul>	<ul style="list-style-type: none"> <li>• Screw inlet valve out of the paint section and clean, see page 37, point 11.2</li> <li>• Screw the outlet valve out of the paint section and clean, see page 37, point 11.3</li> </ul>
<b>Unit exerts suction but no build-up of pressure takes place</b>	<ul style="list-style-type: none"> <li>• Air in the hydraulic system</li> </ul>	<ul style="list-style-type: none"> <li>• Release air from unit (hydraulic system), i.e. turn pressure regulating valve three revolutions to the <b>left</b>. Allow the unit to run one or two minutes. After that, turn pressure regulating valve to the <b>right</b> to set the desired operating pressure.</li> </ul>
<b>Unit exerts pressure and reaches pressure. If the spray gun is removed, the pressure falls appreciably</b>	<ul style="list-style-type: none"> <li>• No tip in the spray gun</li> <li>• Tip too large</li> <li>• Suction filter clogged</li> <li><b>Specially for unit with suction system:</b></li> <li>• Suction pipe not tight</li> <li>• Outlet valve parts worn</li> <li>• Relief valve does not close. Coating material escapes at switch position  (spray) from the return pipe.</li> </ul>	<ul style="list-style-type: none"> <li>• Mount tip.</li> <li>• Selection of smaller tip, see page 46, point 13.4.</li> <li>• Clean suction filter or replace.</li> <li>• Clean and tighten connection points.</li> <li>• Replace outlet valve parts, see page 37, point 11.3.</li> <li>• Screw out relief valve from paint section and clean or replace, see page 38, point 11.5.</li> </ul>
<b>Hard pressure jolts and excessive vibration on the spray gun and unit</b>	<ul style="list-style-type: none"> <li>• High-pressure hose for diaphragm unit not suitable</li> <li>• Outlet valve parts worn</li> </ul>	<ul style="list-style-type: none"> <li>• Use original WAGNER high-pressure hose.</li> <li>• Replace outlet valve parts, see page 37, point 11.3.</li> </ul>

## 10. SERVICING

### 10.1 GENERAL SERVICING

Servicing of the unit should be carried out once annually by the WAGNER service.

1. Check high-pressure hoses, unit connection line, plug and socket for damage.
2. Check inlet valve, outlet valve, diaphragm and filter for wear.
3. Check oil level (fig. 18) in the horizontal set-up.

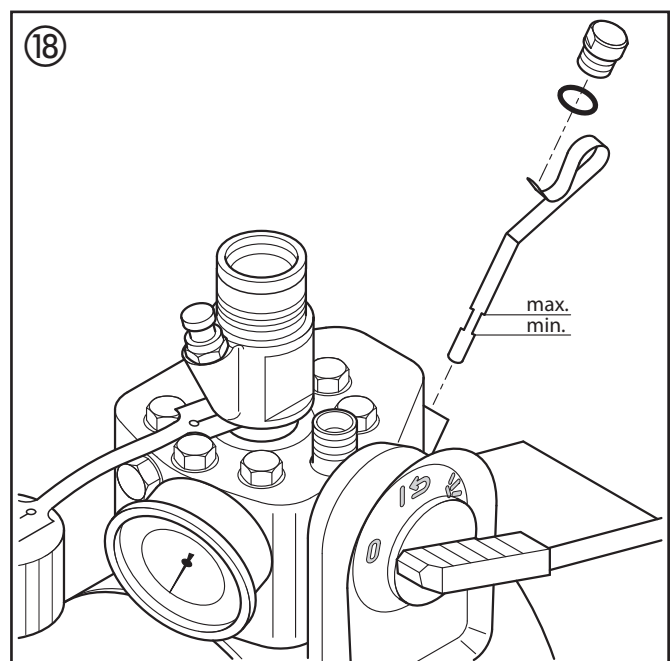

### 10.2 HIGH-PRESSURE HOSE

Check high-pressure hose optically for any cuts or bulges in particular at the connection to the fitting. Union nuts must be able to be turned freely.

## 11. REPAIRS ON THE UNIT



Switch off unit  (OFF).  
Pull mains plug from the socket before all repairs.

### 11.1 INLET VALVE TRIGGER (FIG. 19) WITH SUPER FINISH 31

1. Screw out inlet valve trigger with spanner 17mm.
2. Replace stripper (1) and O-ring (2).

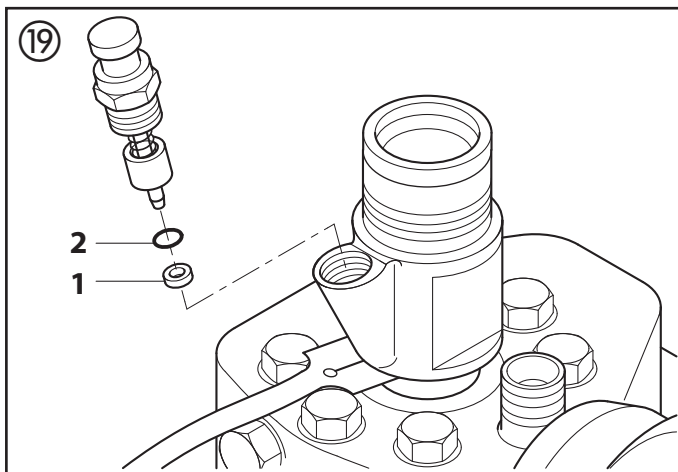

### 11.2 INLET VALVE (FIG. 20)

#### 1. Super Finish 27

Place accompanying spanner 36 mm on the inlet valve housing (1).

#### Super Finish 31

Place accompanying spanner 30 mm on the trigger housing (2).

2. Release inlet valve housing (1) or trigger housing (2) with light blows of a hammer on the end of the spanner.
3. Screw out inlet valve housing or trigger housing with the inlet valve (3) from the paint section.
4. Remove clasp (4) by means of a screwdriver.
5. Place accompanying spanner 30 mm on the inlet valve (3). Withdraw carefully turning the inlet valve.
6. Clean valve seat (5) with cleaning agent and brush.
7. Clean seals (6, 7) and check for damage, replace if necessary.
8. If there are traces of wear in the valve seat, replace inlet valve.

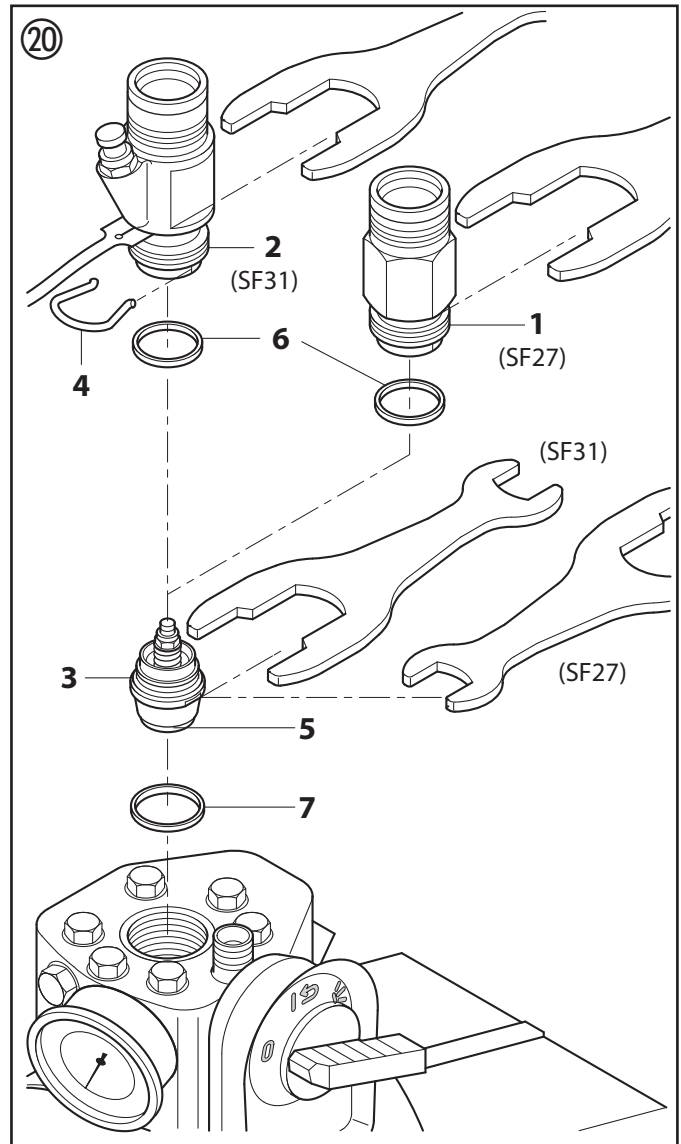

#### Mounting

1. Insert inlet valve (3) into the inlet valve housing (1) or the trigger housing (2) and secure with clasp (4).
2. Screw unit from inlet valve housing or trigger housing and inlet valve into the paint section.
3. Tighten inlet valve housing with spanner 36 mm or trigger housing with spanner 30 mm and tighten with three light blows of the hammer on the end of the spanner.

### 11.3 OUTLET VALVE (FIG. 21)

1. Screw out outlet valve with spanner 22 mm from the paint section.



2. Remove clasp (1) carefully with screwdriver, pressure spring (2) presses parts out 3 to 4.

3. Clean or replace individual parts.
4. Check O-ring (6) for damage.
5. Pay attention to installation position in mounting spring support ring (3), outlet valve seat (4) and seal ring (5), see fig. 21.

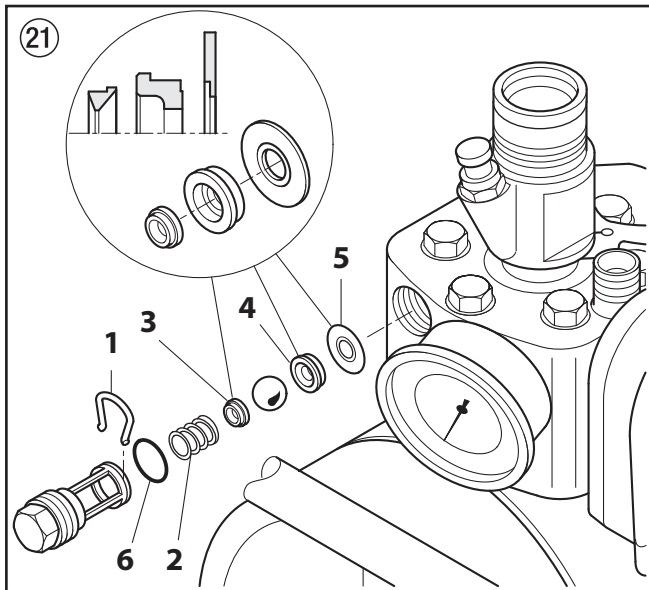

#### 11.4 PRESSURE REGULATING VALVE (FIG. 22, ITEM 1)



**Attention**

Allow pressure regulating valve (1) only to be replaced by the customer service. The max. operating pressure is to be reset by the customer service.

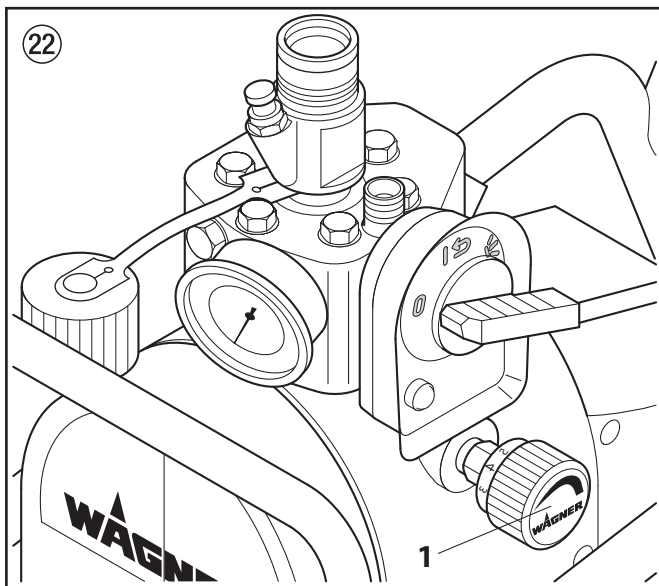

#### 11.5 RELIEF VALVE



**Danger**

Switch off unit  (OFF).  
Pull mains plug from socket before repair.

1. Screw out stop screw (2) from the regulating knob (fig. 23, item 1) into switch position  (spray).
2. Remove regulating knob.

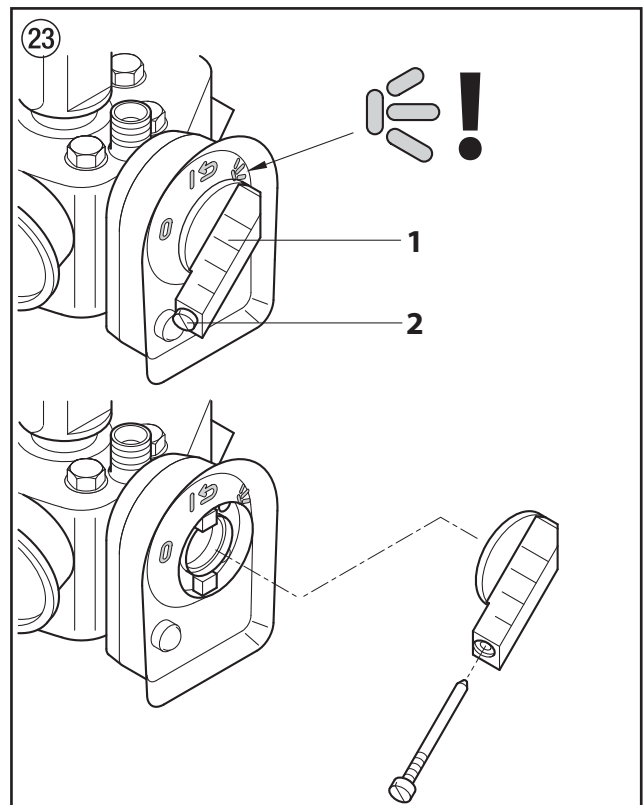

3. Screw out screws (fig. 24, item 3) from the switch housing (4).
4. Remove switch housing (4) from the paint section.
5. Screw relief valve (5) out with the spanner 17mm.
6. Clean valve seat with cleaning agent and brush.
7. Check O-ring (6) for damage, replace if necessary.

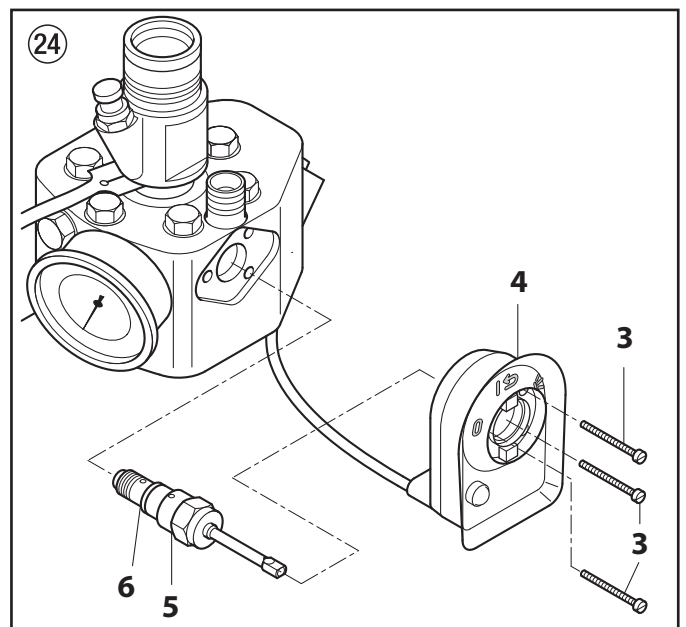

#### Mounting regulating knob (fig. 23, item 1).

1. Place regulating knob first of all onto the axle, turn a little until the regulating knob can be pushed on completely.
2. Turn regulating knob into switch position  (spray). Only in this position can the stop screw (fig. 23, item 2) be pushed in by hand and screwed tight.



## 11.6 EXCHANGING DIAPHRAGM



Switch off unit  (OFF).  
Pull mains plug from the socket before repair.

1. Remove stop screw, regulating knob and switch housing, see under 11.5 relief valve, points 1 to 4.
2. Screw hexagonal screws (fig. 25, item 1) from the flange ring (2) with spanner 19 mm.
3. Remove paint section (3).
4. Remove insert (4) and diaphragm (5).
5. The diaphragm can only be used **once**. **Always** replace diaphragm.
  - Before mounting, clean and dry diaphragm, insert and built-in areas on screw flange (6) and on paint section (3).

### Mounting takes place in the reverse order

6. First of all tighten hexagonal screws (1) with 10 Nm, then crosswise with 70 Nm.

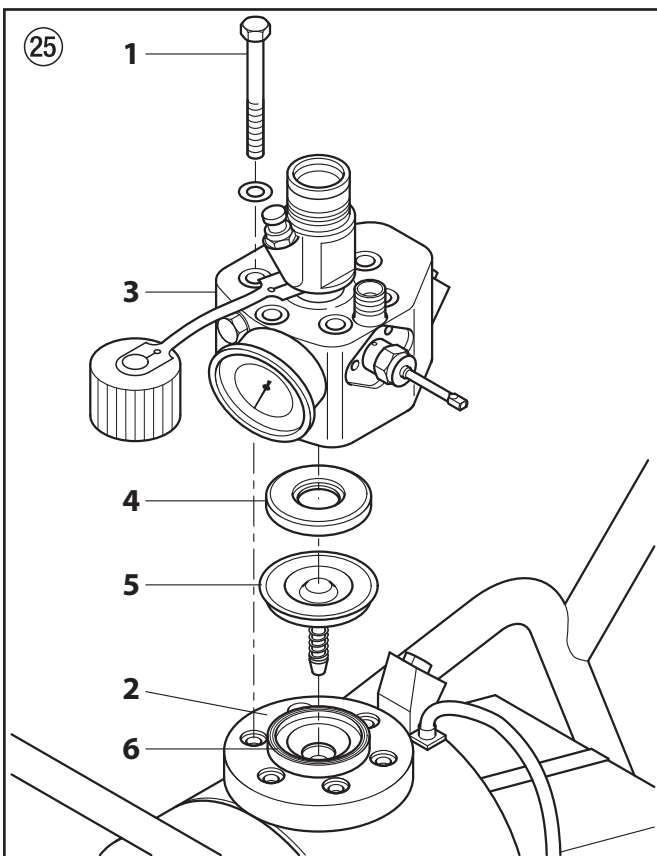

## 11.7 REPLACE UNIT CONNECTION LINE (FIG. 26)



Switch off unit  (OFF).  
Pull mains plug from the socket before repair.

1. Dismount trolley.
2. Screw off housing half with socket and remove.
3. Loosen cable connection (1).
4. Loosen cord in the mains connection terminal (2).
5. Replace unit connection line.

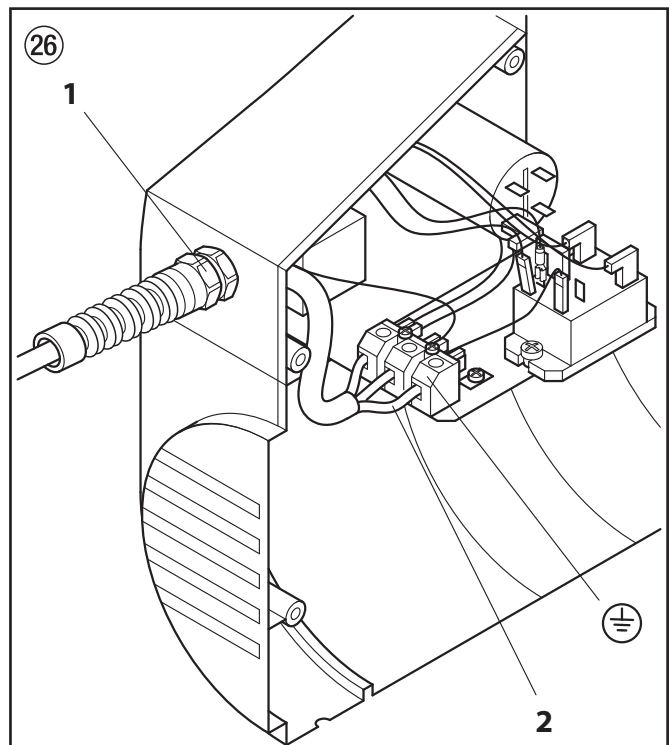

### 11.8 SCHALTPLAN

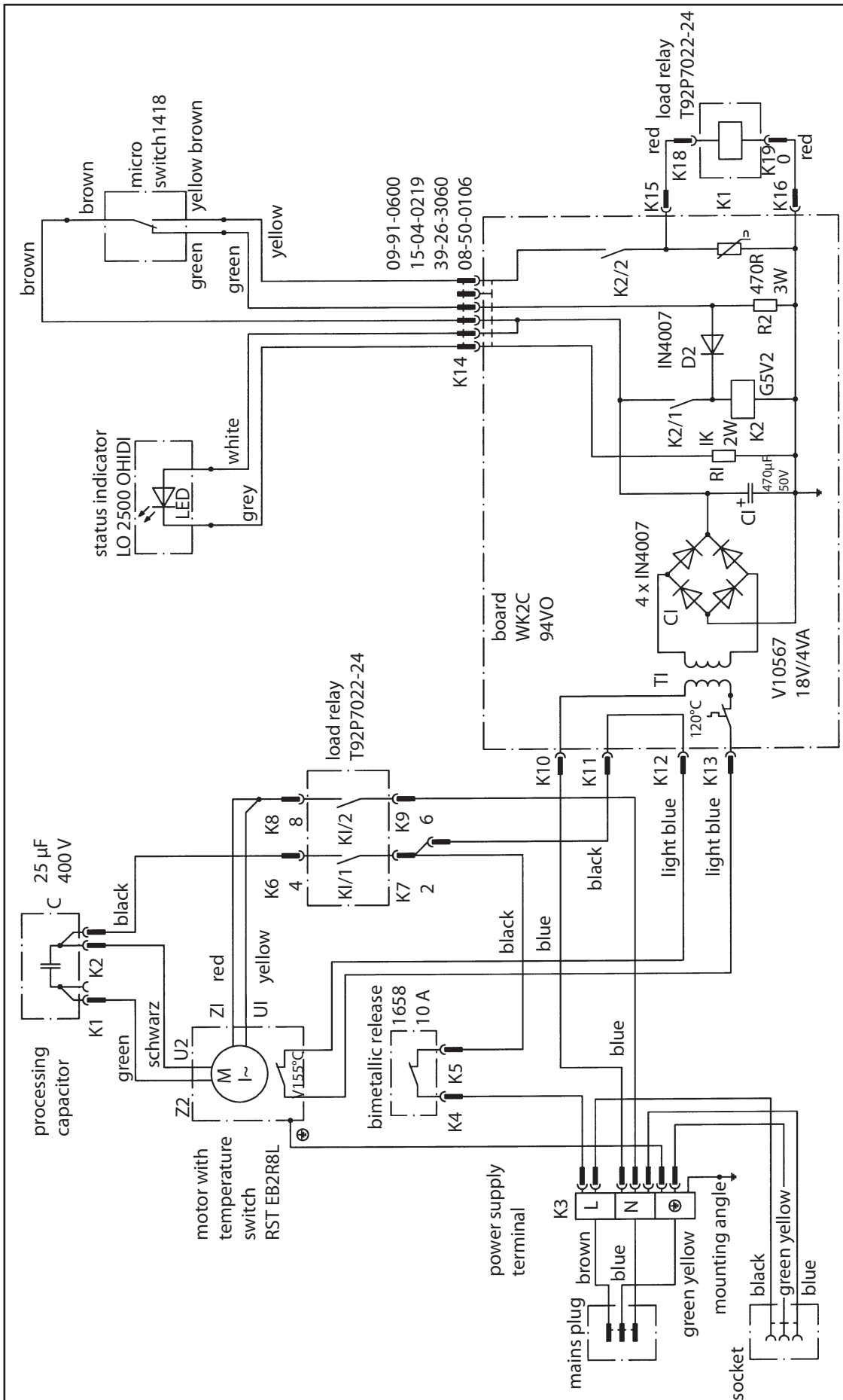

## 12. ACCESSORIES AND SPARE PARTS

### 12.1 ACCESSORIES FOR SUPER FINISH 27 AND 31

Item	SuperFinish 27 Order no.	SuperFinish 31 Order no.	Description
			<b>Accessories illustration, see page 42</b>
1	0341 705	-----	Inlet valve – trigger housing
2	0341 713	-----	Tool box
3	0341 910	0341 910	Hose drum (without high-pressure hose) for 30 m high-pressure hose DN 6 mm
4	0070 212 0070 317 0070 344 0070 326	0070 212 0070 317 0070 344 0070 326	High-pressure filter 200 meshes, 0.085 mm mesh width The high-pressure filter is suitable as a fine filter, each tuned to the tip used. Filter insert 200 meshes (tip size under 011/0.28 mm) Filter insert 100 meshes (tip size over 011/0.28 mm) Filter insert 70 meshes (tip size over 015/0.38 mm)
			<b>Accessories illustration, see page 95</b>
			Spray gun accessories and tips, see page 45/46
5	0257 001 0335 002	0257 001 0335 002	Spray gun AG-09 S (stainless steel model) Spray gun G 12 (aluminium model)
6	0096 004 0096 019 0096 005 0096 006	0096 004 0096 019 0096 005 0096 006	Pole gun 30 cm Pole gun 100 cm Pole gun 150 cm Pole gun 270 cm
7	0097 057	0097 057	Injection lance for regeneration of concrete
8	0345 010	0345 010	Inline Roller IR-100
9	9984 510 9984 507 9984 562	9984 510 9984 507 9984 562	High-pressure hose DN 4 mm, 7.5 m with stainless steel nipple High-pressure hose DN 6 mm, 15 m for dispersion High-pressure hose DN 6 mm, 30 m for dispersion
10	0034 030	0034 030	Double socket for coupling high-pressure hoses
11	0341 263	0341 263	Suction system QuickClean, filter mesh width 1 mm
12	0097 531	0097 531	Filter bag, mesh width 0.3 mm
13	0341 265	0341 265	Upper hopper fittings, 5 litres
14	0097 258 0097 259	0097 258 0097 259	Hopper filling sieve for upper hopper 5 litres. Prevents filling of rough particles from the container. Through this suction problems are avoided. Sieve package (5 pcs) for paint Sieve package (5 pcs) for dispersion
15	0341 266	0341 266	Upper hopper fittings, 20 litres
16	0097 260 0097 261	0097 260 0097 261	Hopper filling sieve for upper hopper 20 litres. Prevents filling of rough particles from the container. Through this suction problems are avoided. Sieve package (5 pcs) for paint Sieve package (5 pcs) for dispersion
17	0034 950 0034 952 0034 951	0034 950 0034 952 0034 951	Metex-Reuse Reuse for pre-filtering of coating material in vessel. Place suction pipe in the reuse. Sieve package (5 pcs) for paint Sieve package (5 pcs) for dispersion
18	0037 607 0003 756  0097 521 0017 408	0037 607 0003 756  0097 521 0017 408	<b>Filter disks Upper hopper, 5 litres</b> Filter disk, mesh width 0.8 mm Filter disk, mesh width 0.4 mm  <b>Filter disks Upper hopper, 20 litres</b> Filter disk, mesh width 0.8 mm Filter disk, mesh width 0.4 mm
19	0034 660	0034 660	Suction system (flexible) for paint
20	0034 630	0034 630	Suction system (flexible) for dispersion
	0340 720	0340 720	Concrete regeneration set (without diagram)

Accessories illustration for Super Finish 27 and 31

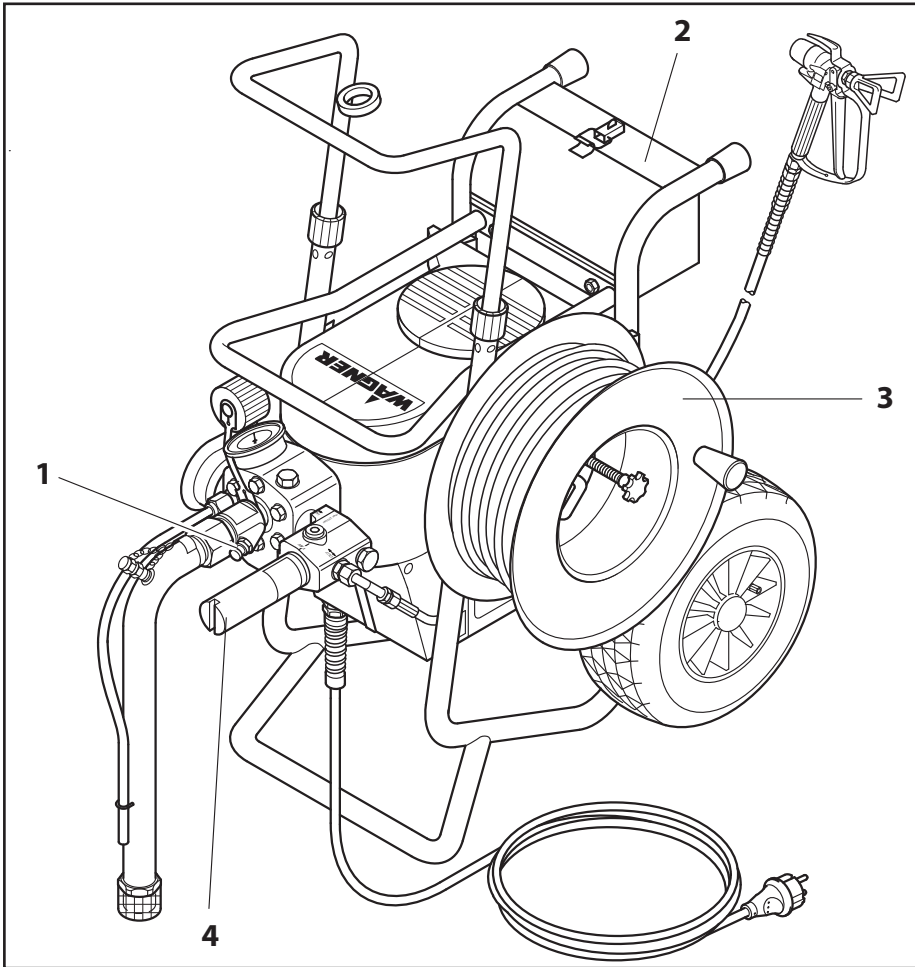

## 12.2 SPARE PARTS LIST PUMP HEAD SUPER FINISH 27 AND 31 (SPARE PARTS DIAGRAM, SEE PAGE 96)

Item	SuperFinish 27 Order no.	SuperFinish 31 Order no.	Description
1	-----	0341 241	Inlet valve trigger
2	-----	0341 316	Stripper
3	-----	9971 486	O-ring 4 x 2
4	0340 339	0340 339	Inlet
5	-----	0341 335	Trigger housing
6	0344 326	-----	Inlet valve housing
7	0341 336	0341 336	Clasp
8	0341 331	0341 331	Sealing ring
9	0341 330	0341 330	Sealing ring
10	0341 247	0341 247	Inlet valve
11	9990 865	9990 865	Dust protection cap
12	0341 322	0341 322	Paint section
13	0341 248	0341 248	Relief valve
14	9974 031	9974 031	O-ring 12 x 1.3
15	0341 414	0341 414	Disk
16	0341 242	0341 242	Diaphragm with insert
18	0341 711	0341 710	Screw flange (item 19 -> 23)
19	0340 361	0340 361	Groove nut
20	0340 368	0340 368	Disk
21	0340 359	0340 359	Rubber disc
22	9971 469	9971 469	O-ring 35 x 2
23	0340 358	0340 358	Ring
24	0341 315	0341 315	Flange ring
25	0340 312	0034 357	Pressure spring
26	0344 327	-----	Spring plate
27	0341 482	0341 311	Piston
28	9991 797	9991 797	Manometer 0 - 400 bar (0 - 40 MPa)
29	9970 109	9970 109	Sealing ring
30	0341 702	0341 702	Outlet valve, service set (item 31 -> 37)
31	0341 347	0341 347	Sealing ring
32	0341 327	0341 327	Outlet valve seat
33	9941 501	9941 501	Ball 11
34	0253 405	0253 405	Spring support ring
35	0341 326	0341 326	Pressure spring
36	9971 470	9971 470	O-ring 20 x 2
37	0341 328	0341 328	Clasp
39	0341 325	0341 325	Valve guide
41	0341 488	0341 488	Anode ring
42	9970 103	9970 103	Sealing ring 16 x 20 x 1.5

Item	SuperFinish 27 Order no.	SuperFinish 31 Order no.	Description
43	0341 350 0344 337	0341 350 -----	Double socket M 16 x 1.5 Double socket NPSM 1/4
44	9920 204	9920 204	Disk 13 DIN 433 (6)
45	9900 217	9900 217	Hexagonal screw M 12 x 60 DIN 931 (6)

## 12.3 SPARE PARTS LIST TROLLEY (SPARE PARTS DIAGRAM, SEE PAGE 97)

Item	SuperFinish 27 Order no.	SuperFinish 31 Order no.	Description
1	0341 211	0341 211	Trolley
2	9920 701	9920 701	Disk
3	0348 349	0348 349	Wheel, pneumatic-tyred
4	9994 902	9994 902	Wheel cap
5	9920 301	9920 301	Disk 8.4
6	9990 866	9990 866	Rubber cap
7	-----	9900 106	Hexagonal screw M 6 x 12
8	-----	0341 372	Tool box
9	-----	9920 304	Disk 6.4
10	-----	9910 102	Hexagonal nut M 6

## 12.4 SPARE PARTS LIST SUCTION SYSTEM (SPARE PARTS DIAGRAM, SEE PAGE 97)

Item	Order no.	Description
	0341 263	Suction system QuickClean
1	0341 435	Filter, mesh width 1 mm
2	0253 211	Return pipe

## 12.5 SPARE PARTS LIST UPPER HOPPER, 5 LITRES (SPARE PARTS DIAGRAM, SEE PAGE 97)

Item	Order no.	Description
	0341 265	Upper hopper fittings, 5 litres
1	0340 901	Cover
2	9902 306	Combination sheet metal screw 3.9 x 13
3	0037 607	Filter disk, mesh width 0.8 mm
4	0340 904	Upper hopper
5	0340 908	Return pipe

## 12.6 SPARE PARTS LIST UPPER HOPPER, 20 LITRES (SPARE PARTS DIAGRAM, SEE PAGE 97)

Item	Order no.	Description
1	0341 266	Upper hopper fittings, 20 litres
2	0097 269	Upper hopper without cover
3	0097 270	Cover
5	9902 306	Combination sheet metal screw 3.9 x 13
6	0097 521	Filter disk, mesh width 0.8 mm
7	9922 609	Securing ring 37 x 1.5

Item	Order no.	Description
9	0037 776	Pressure spring
10	9941 509	Ball 30
13	0097 295	Return pipe
15	0097 271	Container adapter
16	0037 756	Valve support
17	9971 065	O-ring 44 x 3
19	0097 522	Container acceptance

**12.7 SPARE PARTS LIST - PUMP AGGREGATE SUPER FINISH 27 AND 31**  
(SPARE PARTS DIAGRAM, SEE PAGE 98)

Item	SuperFinish 27 Order no.	SuperFinish 31 Order no.	Description
1	9900 336	9900 336	Cylinder head screw M 6 x 40 (2)
3	0340 303	0340 303	Foot (2)
4	0341 208	0341 208	Housing
5	9905 111	9905 111	Oval head screw 5 x 20 (9)
6	9905 112	9905 112	Screw M 6 x 20 (4)
7	9950 241	9950 241	Socket
8	9950 242	9950 242	Seal
9	9900 408	9900 408	Screw M 6 x 16
10	0340 302	0340 302	Connecting plate
11	0341 353	0341 353	Toothed belt
12	0341 352	0341 352	Belt pulley
13	0341 706	0341 706	Eccentric shaft, item 14 -> 21
14	3056 464	3056 464	Securing ring 72 x 2.5
15	9970 532	9970 532	Shaft seal 40 x 72 x 10
16	0341 324	0341 324	Eccentric shaft
17	9960 151	9960 151	Groove ball bearing 6207
18	9922 518	9922 518	Securing ring 35 x 1.5
19	9960 431	9960 431	Roller bearing NUTR 25
20	9922 506	9922 506	Securing ring 25 x 1.2
21	9960 432	9960 432	Cylinder roller bearing NJ 202
24	9900 315	9900 315	Cylinder head screw M 6 x 25 (4)
25	9920 806	9920 806	Disk 6,4 (4)
26	0341 225	0341 220	Hydraulic housing
27	9993 105	9993 105	Nipple
28	0341 445	0341 445	Return hose
29	0288 317	0288 317	O-ring 6.07 x 1.78
30	0288 309	0288 309	Angle piece
31	0341 446	0341 446	Suction hose
32	0341 307	0341 307	Seal
33	0341 309	0341 309	Cover
34	3050 858	3050 858	Disk 5,3 (6)

Item	SuperFinish 27 Order no.	SuperFinish 31 Order no.	Description
35	9906 007	9906 007	Cylinder head screw M 5 x 45 (6)
36	0341 348	0341 348	Oil dip-stick
37	9971 146	9971 146	O-ring 16 x 2
38	0341 349	0341 349	Oil cap screw
39	9953 144	9953 144	Capacitor 25 MF/400 V (230 V~, 50 Hz)
40	9900 341	9900 341	Cylinder head screw M 8 x 12
41	0341 230	0341 230	Electric bracket
43	0341 351	0341 351	Belt disk
44	0341 398	0341 398	Ventilator
45	9922 508	9922 508	Securing ring 14 x 1
46	0341 397	0341 397	Ventilator hood
47	9921 504	9921 504	Spring ring 4
48	9900 737	9900 737	Cylinder head screw M 4 x 6
49	0341 201 0341 204	0341 201 -----	Electric motor 230 V~, 50 Hz Electric motor 220 V~, 60 Hz
51	0340 354	0340 354	Seal
53	0261 352	0261 352	Unit connection line-H07RN – F3G 1.5 – 6 m
54	9951 074	9951 074	Cable screw connection
55	9951 075	9951 075	Nut
56	0341 235	0341 235	Multifunction switch
57	3050 639	3050 639	Cylinder head screw M 4 x 40 (3)
58	0341 237	0341 237	Regulating knob
59	0341 413	0341 413	Stop screw
62	9971 365	9971 365	O-ring 9,25 x 1.78
63	0340 222*	0340 222*	Regulating unit
64	0010 861*	0010 861*	Pressure spring
65	0010 858*	0010 858*	Clamp
66	0010 859*	0010 859*	Stop sleeve
67	0158 251*	0158 251*	Pressure regulating knob
68	0340 223*	0340 223*	Pressure regulating valve
	9984 510 9984 507 9984 562	9984 510 9984 507 9984 562	<b>without diagram</b> High-pressure hose DN 4 mm, 7,5 m with stainless steel nipple High-pressure hose DN 6 mm, 15 m for dispersion High-pressure hose DN 6 mm, 30 m for dispersion

\*When exchanging these parts the operating pressure must be reset by the **customer service**.

# 13. APPENDIX

## 13.1 SELECTION OF TIP

To achieve faultless and rational working, the selection of the tip is of the greatest importance. In many cases the correct tip can only be determined by means of a spraying test.

### Some rules for this:

The spray jet must be even.

If streaks appear in the spray jet the spraying pressure is either too low or the viscosity of the coating material too high.

### Remedy:

Increase pressure or dilute coating material. Each pump conveys a certain quantity in proportion to the size of the tip:

**The following principle is valid:** large tip = low pressure  
 small tip = high pressure

There is a large range of tips with various spraying angles.

## 13.2 SERVICING AND CLEANING OF AIRLESS HARD-METAL TIPS

### Standard tips

If a different tip type has been fitted, then clean it according to manufacturer's instructions.

The tip has a bore processed with the greatest precision. Careful handling is necessary to achieve long durability. Do not forget the fact that the hard-metal insert is brittle! Never throw the tip or handle with sharp metal objects.

### The following points must be observed to keep the tip clean and ready for use:

1. Switch off unit  (OFF).
2. Dismount the tip from the spray gun.
3. Place tip in an appropriate cleaning agent until all coating material residue is dissolved.
4. If there is pressure air, blow out tip.
5. Remove any residue by means of a sharp wooden rod (toothpick).
6. Check the tip with the help of a magnifying glass and, if necessary, repeat points 3 to 5.

## 13.3 SPRAY GUN ACCESSORIES



**Flat jet adjusting tip**  
 up to 250 bar (25 MPa)

Tip marking	Bore mm	Spray width at about 30 cm removal of spray object Pressure 100 bar (10 MPa)	Use	Flat jet adjusting tip Order no.
15	0,13 - 0,46	5 - 35 cm	Paints	<b>0999 057</b>
20	0,18 - 0,48	5 - 50 cm	Paints, fillers	<b>0999 053</b>
28	0,28 - 0,66	8 - 55 cm	Paints, dispersions	<b>0999 054</b>
41	0,43 - 0,88	10 - 60 cm	Rust protection paints - dispersions	<b>0999 055</b>
49	0,53 - 1,37	10 - 40 cm	Large-area coats	<b>0999 056</b>

**Contact protection for the flat jet adjustment tip**

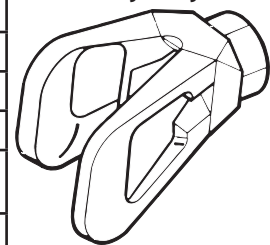

Order no. **0097 294**

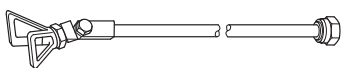
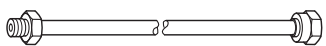
Tip extension with slewable knee joint (without tip)		Tip extension with	
Length 100 cm Length 200 cm Length 300 cm	Order no. <b>0096 015</b> Order no. <b>0096 016</b> Order no. <b>0096 017</b>	Length 15 cm Length 30 cm Length 45 cm Length 60 cm	Order no. <b>0999 320</b> Order no. <b>0999 321</b> Order no. <b>0999 322</b> Order no. <b>0999 323</b>

## 13.4 Airless tip table

**Wagner Professional tip**  
up to 270 bar  
(27 MPa)



without tip  
F thread (11/16 - 16 UN)  
for Wagner spray guns  
**Order no. 0556 042**

without tip  
G thread (7/8 - 14 UN)  
for Graco/Titan spray guns  
**Order no. 0556 041**

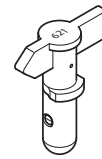

Application	Tip marking	Spray angle	Bore inch / mm	Spraying width mm 1)	Order no.	
Natural paints Clear paints Oils	Spray gun filter "RED"	407	40°	0.007 / 0.18	160	0552 407
		507	50°	0.007 / 0.18	190	-----
		209	20°	0.009 / 0.23	145	0552 209
		309	30°	0.009 / 0.23	160	0552 309
		409	40°	0.009 / 0.23	190	0552 409
		509	50°	0.009 / 0.23	205	0552 509
		609	60°	0.009 / 0.23	220	0552 609
Synthetic-resin paints PVC paints	Spray gun filter "RED"	111	10°	0.011 / 0.28	85	0552 111
		211	20°	0.011 / 0.28	95	0552 211
		311	30°	0.011 / 0.28	125	0552 311
		411	40°	0.011 / 0.28	195	0552 411
		511	50°	0.011 / 0.28	215	0552 511
		611	60°	0.011 / 0.28	265	0552 611
Paints, primers Zinc chromate base Fillers	Spray gun filter "RED"	113	10°	0.013 / 0.33	100	0552 113
		213	20°	0.013 / 0.33	110	0552 213
		313	30°	0.013 / 0.33	135	0552 313
		413	40°	0.013 / 0.33	200	0552 413
		513	50°	0.013 / 0.33	245	0552 513
		613	60°	0.013 / 0.33	275	0552 613
		813	80°	0.013 / 0.33	305	0552 813
Fillers Spray plasters Rust protection paints	Spray gun filter "YELLOW"	115	10°	0.015 / 0.38	90	0552 115
		215	20°	0.015 / 0.38	100	0552 215
		315	30°	0.015 / 0.38	160	0552 315
		415	40°	0.015 / 0.38	200	0552 415
		515	50°	0.015 / 0.38	245	0552 515
		615	60°	0.015 / 0.38	265	0552 615
		715	70°	0.015 / 0.38	290	0552 715
		815	80°	0.015 / 0.38	325	0552 815
Spray plasters Rust protection paints Red lead Latex paints	Spray gun filter "WHITE"	217	20°	0.017 / 0.43	110	0552 217
		317	30°	0.017 / 0.43	150	0552 317
		417	40°	0.017 / 0.43	180	0552 417
		517	50°	0.017 / 0.43	225	0552 517
		617	60°	0.017 / 0.43	280	0552 617
		717	70°	0.017 / 0.43	325	0552 717
		219	20°	0.019 / 0.48	145	0552 219
		319	30°	0.019 / 0.48	160	0552 319
		419	40°	0.019 / 0.48	185	0552 419
		519	50°	0.019 / 0.48	260	0552 519
		619	60°	0.019 / 0.48	295	0552 619
		719	70°	0.019 / 0.48	320	0552 719
		819	80°	0.019 / 0.48	400	0552 819
Mica paints Zinc dust paints Dispersions	Spray gun filter "WHITE"	221	20°	0.021 / 0.53	145	0552 221
		421	40°	0.021 / 0.53	190	0552 421
		521	50°	0.021 / 0.53	245	0552 521
		621	60°	0.021 / 0.53	290	0552 621
		821	80°	0.021 / 0.53	375	0552 821
Rust protection paints	Spray gun filter "WHITE"	223	20°	0.023 / 0.58	155	0552 223
		423	40°	0.023 / 0.58	180	0552 423
		523	50°	0.023 / 0.58	245	0552 523
		623	60°	0.023 / 0.58	275	0552 623
		723	70°	0.023 / 0.58	325	0552 723
		823	80°	0.023 / 0.58	345	0552 823
Dispersions Binder, glue and filler paints	Spray gun filter "GREEN"	225	20°	0.025 / 0.64	130	0552 225
		425	40°	0.025 / 0.64	190	0552 425
		525	50°	0.025 / 0.64	230	0552 525
		625	60°	0.025 / 0.64	250	0552 625
		825	80°	0.025 / 0.64	295	0552 825
		227	20°	0.027 / 0.69	160	0552 227
		427	40°	0.027 / 0.69	180	0552 427
		527	50°	0.027 / 0.69	200	0552 527
		627	60°	0.027 / 0.69	265	0552 627
		827	80°	0.027 / 0.69	340	0552 827
		629	60°	0.029 / 0.75	285	0552 629
		231	20°	0.031 / 0.79	155	0552 231
		431	40°	0.031 / 0.79	185	0552 431
		531	50°	0.031 / 0.79	220	0552 531
		631	60°	0.031 / 0.79	270	0552 631
		433	40°	0.033 / 0.83	220	0552 433
		235	20°	0.035 / 0.90	160	0552 235
		435	40°	0.035 / 0.90	195	0552 435
		535	50°	0.035 / 0.90	235	0552 535
635	60°	0.035 / 0.90	295	0552 635		
839	80°	0.039 / 0.99	480	-----		
Large-area coatings	Spray gun filter "GREEN"	243	20°	0.043 / 1.10	185	0552 243
		543	50°	0.043 / 1.10	340	0552 543
		552	50°	0.052 / 1.30	350	0552 552

1)Spray width at about 30 cm to the object and 100 bar (10 MPa) pressure with synthetic-resin paint 20 DIN seconds.



Super Finish 27 • 31

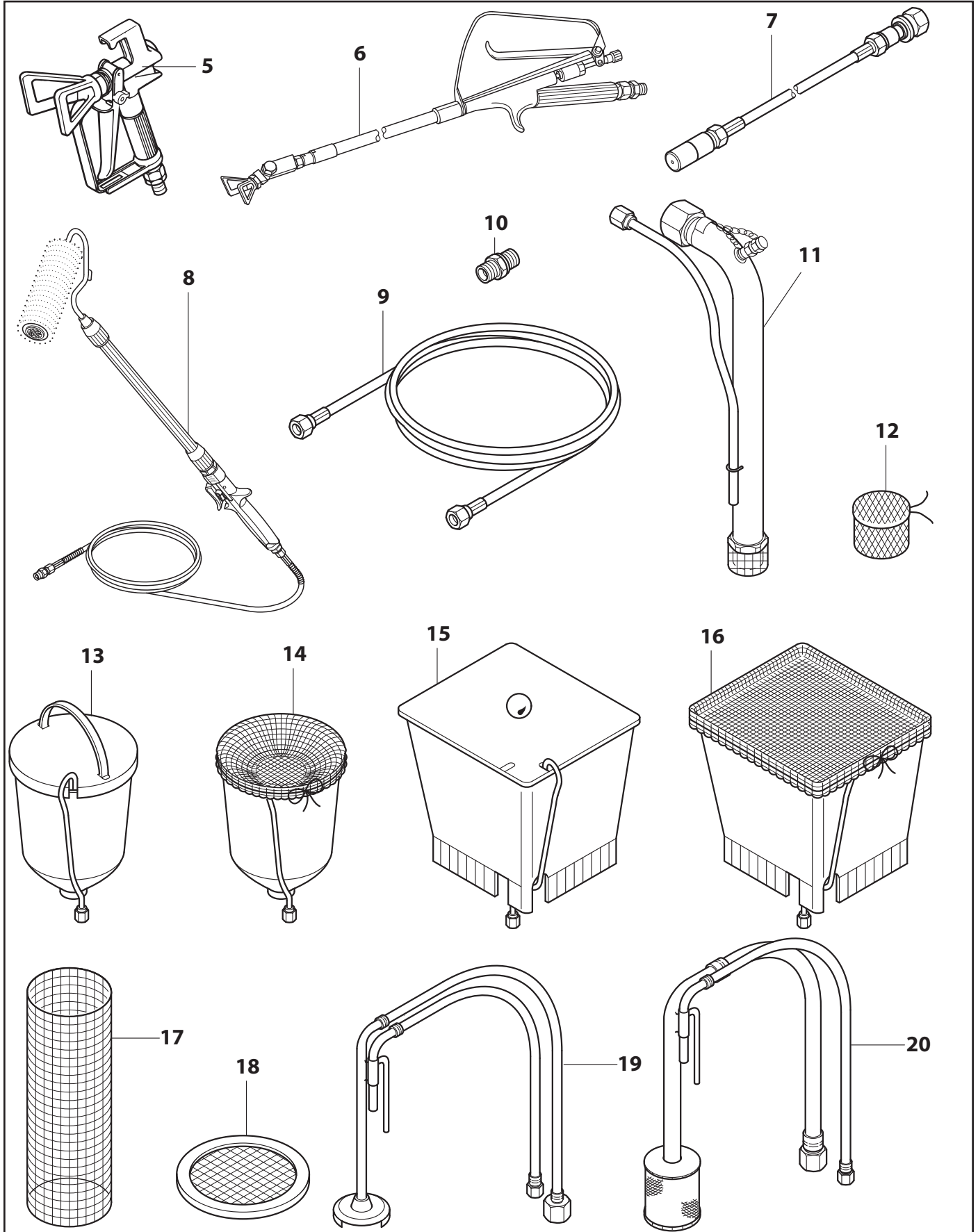

**Super Finish 27 • 31**

**(D)** Pumpenkopf

**(GB)** Pump head

**(F)** Tête de pompe

**(I)** Testa della pompa

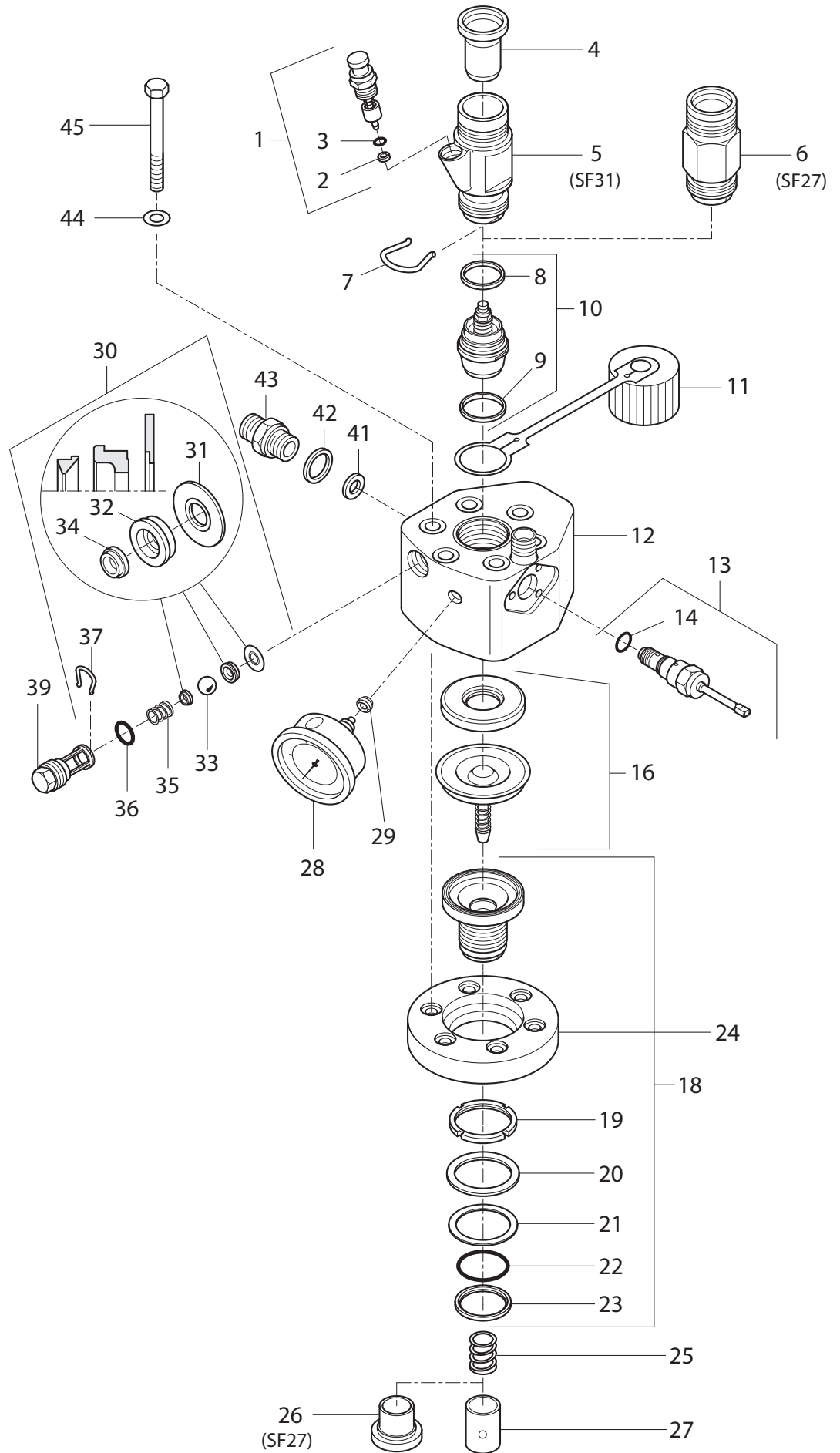



(D) Ersatzteilbild (GB) Spare parts diagram (F) Illustration des pièces de rechange

(I) Schema pezzi di ricambio

Super Finish 27 • 31

(D) Pumpen-Aggregat

(GB) Pump aggregate

(F) Groupe de pompe

(I) Aggregato pompe

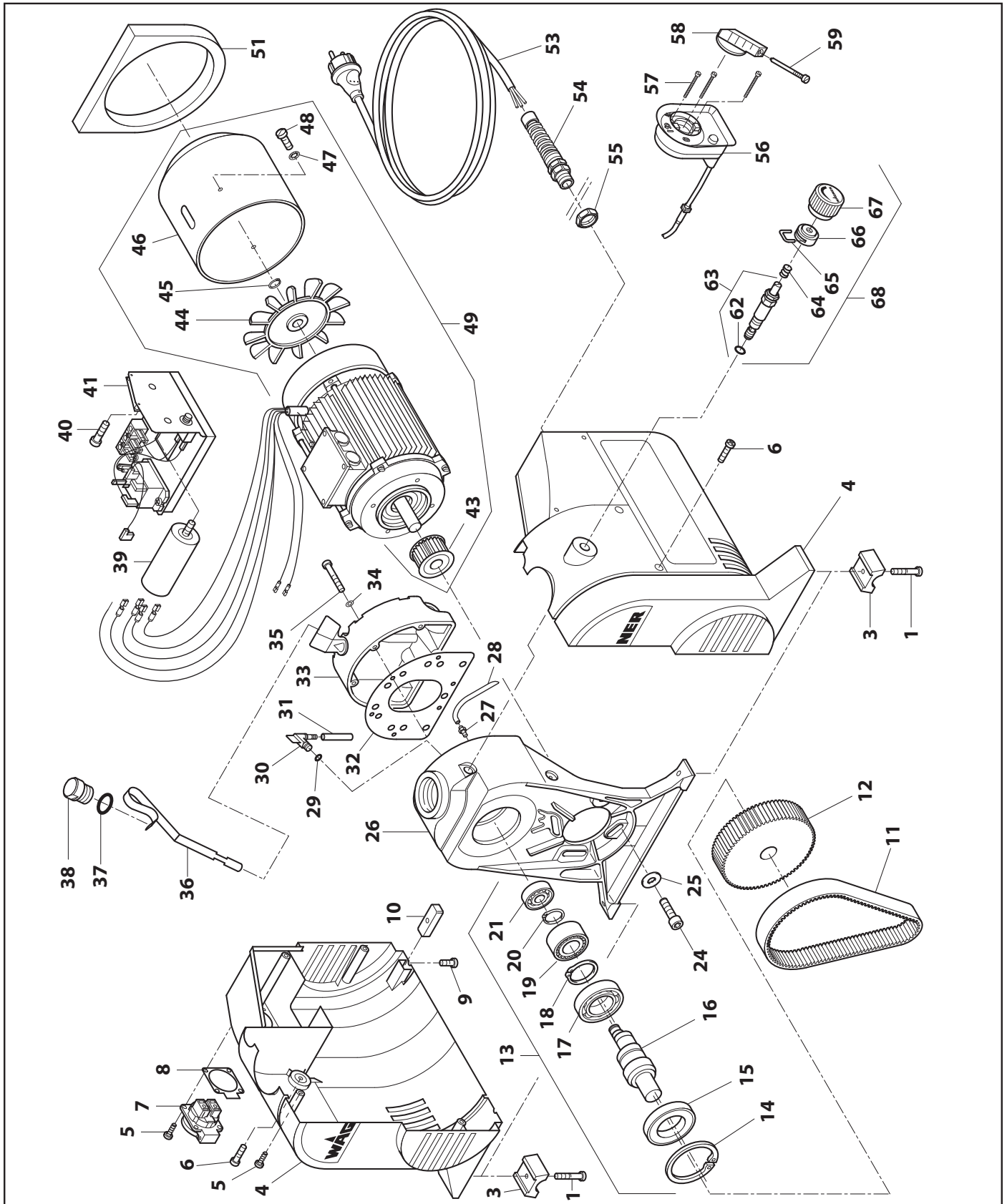

## Important notes on product liability

As a result of an EC regulation being effective as from January 1, 1990, the manufacturer shall only be liable for his product if all parts come from him or are released by him, and if the devices are properly mounted and operated.

If the user applies outside accessories and spare parts, the manufacturer's liability can fully or partially be inapplicable; in extreme cases usage of the entire device can be prohibited by the competent authorities (employer's liability insurance association and factory inspectorate division).

Only the usage of original WAGNER accessories and spare parts guarantees that all safety regulations are observed.

## CE Declaration of conformity

Herewith we declare that the supplied version of

**WAGNER Super Finish 27, 230 V, 50 Hz**

**WAGNER Super Finish 27, 220 V, 60 Hz**

**WAGNER Super Finish 31, 230 V, 50 Hz**

Complies with the following provisions applying to it:

**73/23 EEC, 89/336 EEC and 89/392 EEC.**

Applied harmonized standards, in particular:

**EN 292-1/-2, EN 55014, EN 55104, EN 60204-1,**

**EN 6100-3-2**

Applied national technical standards and specifications, in particular:

**VBG 5, BGV D15**

**Date: 18. 12. 2000**



Executive Officer



Signature Head of Development

## Note on disposal

In observance of the European Directive 2002/96/EC on waste electrical and electronic equipment and implementation in accordance with national law, this product is not to be disposed of together with household waste material but must be recycled in an environmentally friendly way!



Wagner or one of our dealers will take back your used Wagner waste electrical or electronic equipment and will dispose of it for you in an environmentally friendly way. Please ask your local Wagner service centre or dealer for details or contact us direct.

## Warranty

(Status 01.02.2009)

### 1. Scope of guarantee

All Wagner professional colour application devices (hereafter referred to as products) are carefully inspected, tested and are subject to strict checks under Wagner quality assurance. Wagner exclusively issues extended guarantees to commercial or professional users (hereafter referred to as "customer") who have purchased the product in an authorised specialist shop, and which relate to the products listed for that customer on the Internet under [www.wagner-group.com/profi-guarantee](http://www.wagner-group.com/profi-guarantee).

The buyer's claim for liability for defects from the purchase agreement with the seller as well as statutory rights are not impaired by this guarantee.

We provide a guarantee in that we decide whether to replace or repair the product or individual parts, or take the device back and reimburse the purchase price. The costs for materials and working hours are our responsibility. Replaced products or parts become our property.

### 2. Guarantee period and registration

The guarantee period amounts to 36 months. For industrial use or equal wear, such as shift operations in particular, or in the event of rentals it amounts to 12 months.

Systems driven by petrol or air are also guaranteed for a 12 month period.

The guarantee period begins with the day of delivery by the authorised specialist shop. The date on the original purchase document is authoritative.

For all products bought in authorised specialist shops from 01.02.2009 the guarantee period is extended to 24 months providing the buyer of these devices registers in accordance with the following conditions within 4 weeks of the day of delivery by the authorised specialist shop.

Registration can be completed on the Internet under [www.wagner-group.com/profi-guarantee](http://www.wagner-group.com/profi-guarantee).

The guarantee certificate is valid as confirmation, as is the original purchase document that carries the date of the purchase. Registration is only possible if the buyer is in agreement with having the data being stored that is entered during registration.

When services are carried out under guarantee the guarantee period for the product is neither extended nor renewed.

Once the guarantee period has expired, claims made against the guarantee or from the guarantee can no longer be enforced.

### 3. Handling

If defects can be seen in the materials, processing or performance of the device during the guarantee period, guarantee claims must be made immediately, or at the latest within a period of 2 weeks.

The authorised specialist shop that delivered the device is entitled to accept guarantee claims. Guarantee claims may also be made to the service centres named in our operating instruc-

tions. The product has to be sent without charge or presented together with the original purchase document that includes details of the purchase date and the name of the product. In order to claim for an extension to the guarantee, the guarantee certificate must be included.

The costs as well as the risk of loss or damage to the product in transit or by the centre that accepts the guarantee claims or who delivers the repaired product, are the responsibility of the customer.

#### 4. Exclusion of guarantee

Guarantee claims cannot be considered

- for parts that are subject to wear and tear due to use or other natural wear and tear, as well as defects in the product that are a result of natural wear and tear, or wear and tear due to use. This includes in particular cables, valves, packaging, jets, cylinders, pistons, means-carrying housing components, filters, pipes, seals, rotors, stators, etc. Damage due to wear and tear that is caused in particular by sanded coating materials, such as dispersions, plaster, putty, adhesives, glazes, quartz foundation.
- in the event of errors in devices that are due to non-compliance with the operating instructions, unsuitable or unprofessional use, incorrect assembly and/or commissioning by the buyer or by a third party, or utilisation other than is intended, abnormal ambient conditions, unsuitable coating materials, unsuitable operating conditions, operation with the incorrect mains voltage supply/frequency, over-operation or defective servicing or care and/or cleaning.
- for errors in the device that have been caused by using accessory parts, additional components or spare parts that are not original Wagner parts.
- for products to which modifications or additions have been carried out.
- for products where the serial number has been removed or is illegible
- for products to which attempts at repairs have been carried out by unauthorised persons.
- for products with slight deviations from the target properties, which are negligible with regard to the value and usability of the device.
- for products that have been partially or fully taken apart.

#### 5. Additional regulations.

The above guarantees apply exclusively to products that have been bought by authorised specialist shops in the EU, CIS, Australia and are used within the reference country.

If the check shows that the case is not a guarantee case, repairs are carried out at the expense of the buyer.

The above regulations manage the legal relationship to us concludingly. Additional claims, in particular for damages and losses of any type, which occur as a result of the product or its use, are excluded from the product liability act except with regard to the area of application.

Claims for liability for defects to the specialist trader remain unaffected.

German law applies to this guarantee. The contractual language is German. In the event that the meaning of the German and a foreign text of this guarantee deviate from one another,

the meaning of the German text has priority.

J. Wagner GmbH  
 Division Professional Finishing  
 Otto Lilienthal Strasse 18  
 88677 Markdorf  
 Federal Republic of Germany

Subject to modifications · Printed in Germany

## Free Manuals Download Website

<http://myh66.com>

<http://usermanuals.us>

<http://www.somanuals.com>

<http://www.4manuals.cc>

<http://www.manual-lib.com>

<http://www.404manual.com>

<http://www.luxmanual.com>

<http://aubethermostatmanual.com>

Golf course search by state

<http://golfingnear.com>

Email search by domain

<http://emailbydomain.com>

Auto manuals search

<http://auto.somanuals.com>

TV manuals search

<http://tv.somanuals.com>