

WAGNER®

Fine Finish™

**STATI-KIT 2000™
ELECTROSTATIC
SPRAYING SYSTEM**

Model No. 0292003

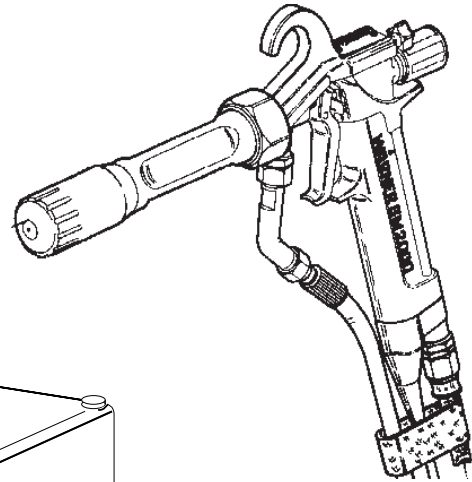

OWNER'S MANUAL



APPROVED
FOR ELECTROSTATIC FINISHING APPLICATION

POWER PACK, VM 200	P/N 0179637
POWER PACK, EPP 200	P/N 0179633
POWER PACK, EPP 2000	
SPRAY GUN, GM 2000 EAC	P/N 0179673
AIR HOSE	P/N 0128510
FLUID HOSE	P/N 9984482
SPRAY GUN, GM 2000 EA	P/N 0179221
AIR HOSE	
FLUID HOSE	P/N 0179248

P/N 0179966

CAUTION

**Read Rules for
Safe Operation
and Instructions
Carefully**

Form No.0292522-4/91A

CONTENTS

SAFETY PRECAUTIONS	3-6
SPECIFICATIONS.....	7
INTRODUCTIONS	7
GENERAL DESCRIPTION	8
MOUNTING ARRANGEMENT	9
SET UP	9
OPERATION	10
CLEAN UP	11
TIP CHANGE	12
FILTER REPLACEMENT	13
FRONT & REAR PACKING REPLACEMENT	13
TROUBLE SHOOTING	14-15
PARTS LIST	16-17
SPARE TIPS	18
WARRANTY	20

SAFETY PRECAUTIONS

This manual contains information which must be read and understood before using the equipment. When you come to an area which has one of the following symbols, pay particular attention and make certain to heed the safeguard.



Important safety information indicates a hazard which may cause serious injury or loss of life.



Important information that tells how to prevent damage to equipment or how to avoid causes of minor injuries.

Notes: Gives important information which should be given special attention.



HAZARD

Electrostatic arcing may cause an explosion or fire. Solvent and paint fumes can explode or ignite causing property damage and/or severe injury.

PREVENTION

- Operator must be grounded. Grounding straps must be used when wearing rubber soled shoes.
- Operator must be in contact with the spray gun handle; cut out palm section of any work gloves to be used.
- Operator must remove all metal objects from his or her person which are not grounded.
- The object being sprayed must be grounded.
- All metal objects within the spray area must be grounded (including spray booth, part hangers, fire extinguishers, etc.)
- Grounded conductive floor must be provided in spray area.
- Turn off the Power Pack and unplug from outlet before flushing out the gun, cleaning or replacing parts on the gun such as changing tips.

Explosion or fire. Solvent and paint fumes can explode or ignite causing property damage and/or severe injury.

- Exhaust and fresh air introduction must be provided to keep the air within the spray area free of accumulation of flammable vapors.
- Smoking must not be allowed in spray area.
- Fire extinguishing equipment must be present and in working order.
- Electrostatic arcing must be prevented. (See Electrostatic arcing)
- When flushing the system use only solvents recommended by the coatings manufacturer. Be sure Power Pack is turned off and unplugged.
- Use only grounded high pressure fluid hose.
- Avoid all ignition sources such as static electricity sparks, open flames such as pilot lights, hot objects such as cigarettes and sparks from connecting and disconnecting power cords and working light switches.



HAZARD

PREVENTION

Toxic Substances: Some materials may be harmful if inhaled or come in contact with the skin.

- Follow the requirements of the Material Safety Data Sheet supplied by the coatings manufacturer.
- Exhaust and fresh air introduction must be provided within the spray area to keep the air free of accumulations of toxic materials.
- Wear a mask or respirator. Read all instructions for the mask to insure that it will provide the necessary protection against the inhalation of harmful vapors.

Explosion hazard incompatible materials. May cause property damage or severe injury.

- Some spray pumps prohibit the use of halogenated hydrocarbon solvents.
- Halogenated hydrocarbon solvents such as methylene chloride and 1,1,1 - Trichlorethane are not compatible with aluminum and may cause an explosion. If you are not sure of a material's compatibility with aluminum, contact your coatings supplier. Halogenated hydrocarbon solvents are compatible with the GM2000 spray gun and may be used if the solvents are compatible with the pump and other accessories.

Injection. A high pressure stream of paint can pierce the skin and underlying tissues, leading to serious injury and possible amputation.

- Maximum operating range of the gun - **3625 PSI fluid pressure.**
- NEVER aim the gun at any part of the body under any circumstances.
- NEVER let any part of the body come in contact with the fluid stream. **DO NOT** come in contact with a fluid stream created by a leak in the fluid hose.
- Paint hose can develop leaks from wear, kinking, abuse etc. A leak is capable of injecting material into the skin. Paint hose should be inspected before each use. Replace a damaged hose.
- NEVER put hand in front of the gun. Gloves will not provide protection against an injection injury.
- ALWAYS lock the gun trigger when cleaning, changing tips or leaving unattended.
- ALWAYS shut fluid pump off and release all pressure before servicing, cleaning, or changing tips.

WARNING

HAZARD

PREVENTION

Injection (Con't)

- All accessories must be rated at or above the maximum pressure rating of spray pump (includes spray tips, guns, extensions and fluid hose).
- If you are injected, see a physician immediately.

DO NOT TREAT AS A SIMPLE CUT! It can lead to amputation. See a physician immediately.

NOTE TO PHYSICIAN: Injection into the skin is a traumatic injury. It is important to treat the injury surgically as soon as possible. DO NOT delay treatment to research toxicity. Toxicity is a concern with some coatings injected directly into the blood stream. Consultation with a plastic surgeon or reconstructive hand surgeon may be advisable.

General

- Read all instructions and safety precautions before operating.
- Comply with all appropriate local, state and national codes governing ventilation, fire prevention, and operation of Electrostatic equipment usage.
- The United States Government Safety Standards have been adopted under the Occupational Safety and Health Act. These standards, particularly the General Standards, Part 1910 and the Construction Standard, Part 1926, should be consulted.
- NFPA Standard No. 33 is to be followed when setting up your spray area. Contact the National Fire Protection Association, Batterymarch Park, Quincy, Massachusetts, 02269 for more information.
- Check with insurance company for additional requirements.
- DO NOT substitute any other spray gun or power pack with this system. Use only identical replacement parts.

SPECIFICATIONS

GM2000 EAC SPRAYGUN (P/N 0179673)

Air Pressure, max.	145 psi
Material Pressure, max.	3625 psi
Air Volume	10 CFM@ 45 PSI
Material Volume	Varies due to Tip size
Air Connector	1/4 inch
Material Connector	NPS 1/4
Length	11.8 inches
Height	10 inches
Weight	21 oz.
Input voltage	22 VAC
Input Current, max.	0.8 A
Frequency	26 kHz
High Voltage	80 kV DC
Output Current, max.	100 A AC
Polarity	Negative
Cable, Connecting	36 ft.

VM200 ELECTROSTATIC POWER PACK (P/N 0179637)

Length	7.5 inches
Width	4.75 inches
Height	3.5 inches
Weight	3.9 lbs.
Input - VAC	110 - 60 Hz
Power consumption max.	15 W
Output Voltage	80 KV
Output Current max	0.7 A
Output Frequency	17 kHz
Power Cord	9 ft.

NOTE

Use only coating materials with a specific resistance of 50 - 3.500 K Ohms . If you are not sure of the specific resistance check with the coatings supplier before using.

INTRODUCTION

INTRODUCTION TO ELECTRO-STATIC SPRAYING

The spraying medium is atomized using a pneumatic or diaphragm pump and a booster air feed supply. A high DC voltage (up to 80 kV), applied across the grounded component and the electrode fitted to the gun body generates an electric field and applies a negative charge to the paint particles. These repel each other as they move from gun to workpiece and so distribute evenly through the fine spray cloud and then uniformly deposit on the positively grounded surface. Particles shooting past the component remain trapped in the electric field and deposit on the backside of the work object. Effective material yield up to 90%, time savings up to 80%, markedly improved quality of finish, less cleaning and a healthier environment are the principal properties of the process.

FEATURES:

- Minimum overspray
- Coating by electrostatic wrap-around action
- Good atomization of charged particles

ADVANTAGES:

- Effective material utilization up to 90%
- Enormous time and labor savings

GENERAL DESCRIPTION

GM2000 EAC SPRAY GUN

The GM2000 EAC Electrostatic Air Coat Spraygun is very light and easy to service. It can be used up to a maximum operating pressure of 3625 PSI.

Trigger Lock: Turn knob **clockwise** to lock the trigger.

Electrostatic On/Off Switch: This switch can be used to turn off the electrostatics. Sometimes the Faraday Cage effect prevents proper coverage on inside corners. If you run into this problem turn this switch off (up), spray the inside corner(s), then turn the switch back on (down), and resume electrostatic spraying.

Fluid Inlet: Securely fasten airless hose to this threaded port. Be sure to use only hose with adequate pressure rating.

Air Inlet: Securely fasten air hose to this threaded port.

Air Adjustment: This knob can be used to regulate the amount of air that is used in spraying. Turn knob clockwise until it closes, slowly turn knob counterclockwise until adequate air flow results.

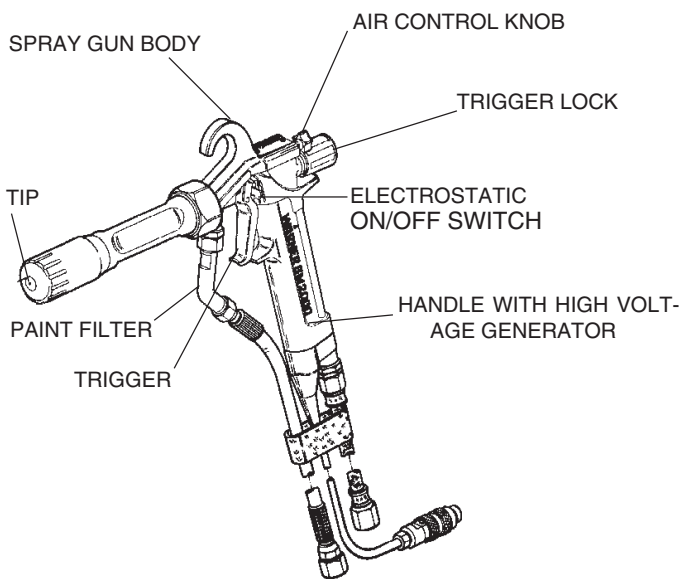

Figure 1

VM 200 ELECTROSTATIC POWER PACK

The heavy metal case is water tight. All external components and operating controls, as well as the case finish are largely solvent-resistant.

With the power switch on, the green pilot lamp lights up. Internal components now convert the supplied voltage into a pulsating DC voltage of 12 V and 17 kHz frequency. This low output voltage supplies the GM 2000 EAC gun via the connecting cable.

When the gun trigger is pulled, a solenoid-operated Reed contact initiates the switching on of the high voltage, signalled by lighting up of the red high voltage lamp. Via the connecting cable to the gun, the 12 V/17 kHz, medium-frequency, low voltage is now fed to the high-voltage generating section inside the guard of the gun. Here, a transformer within the cascade converts the low voltage into a high voltage of 80 kV and applies this with negative polarity to the electrodes.

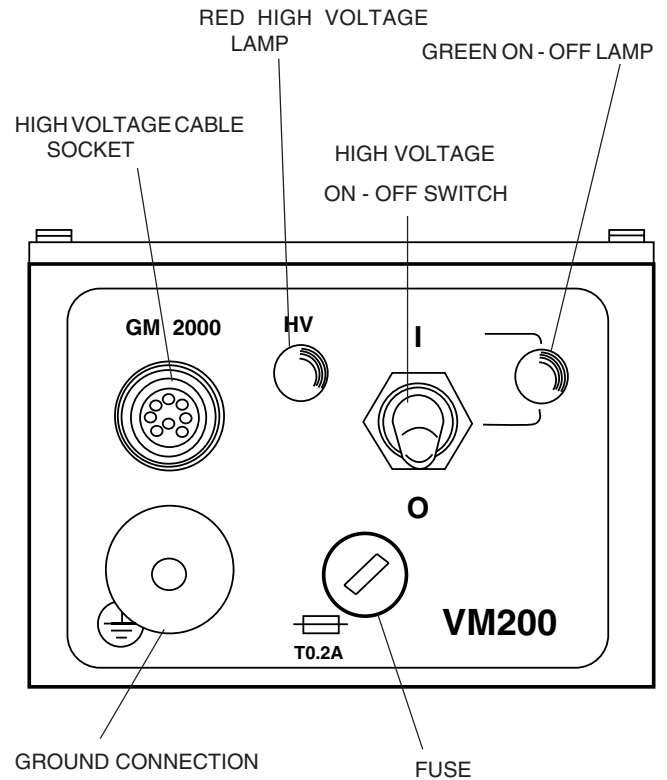

Figure 2

TYPICAL MOUNTING ARRANGEMENT WAGNER AIRLESS SPRAYER

MOUNTING INSTRUCTIONS

1. Use the allen wrench provided, attach the mounting bracket (1) to the power pack (2) with the 2.4mm lockwashers (3) and socket head screws (4).
2. Place the power pack/mounting bracket assembly on any 1" diameter tube, preferably as illustrated below.
3. Align support clamps (5) with mounting bracket (1), using the other allen wrench provided, attach the 2 pieces with the 4-1/4" lockwashers (6) and socket head screws (7), tightening down equally on both sides.

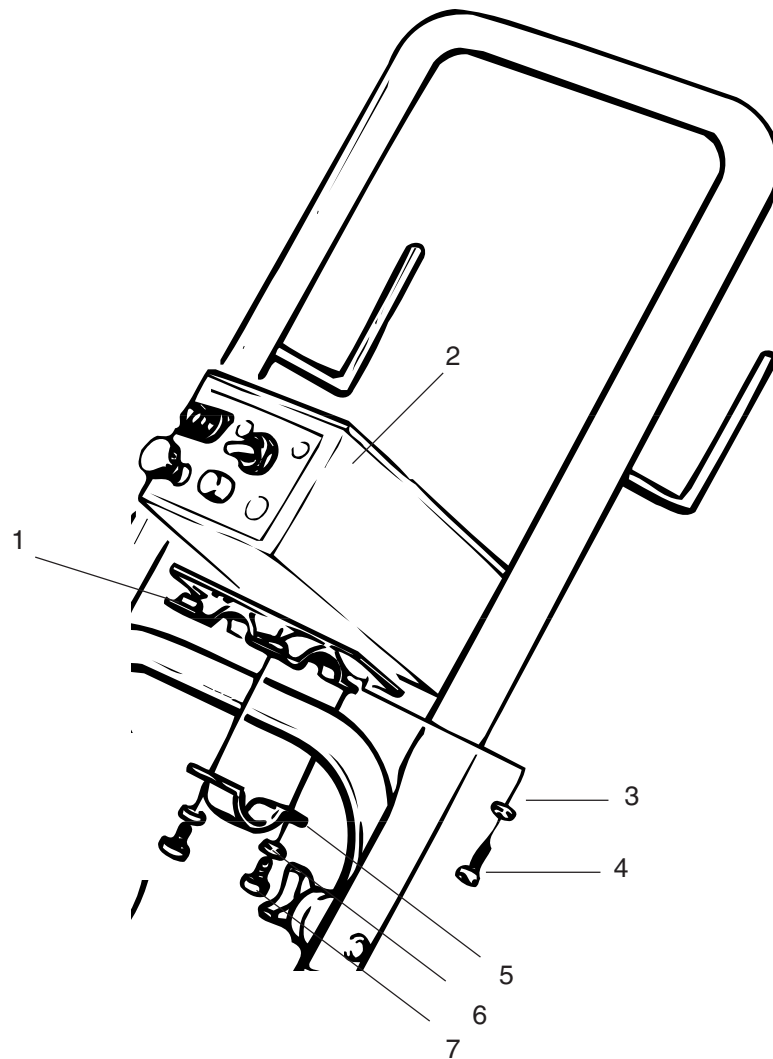

Figure 3

SET-UP

SET-UP VM 200 POWER PACK:

1. GM 2000 EAC Socket Outlet
2. Ground Connection Knob
3. Fuse
4. On/Off Switch
5. On/Off Indicator Lamp (Green)
6. High Voltage Indicator Lamp (Red)
7. Grounding Cable
8. Ground Washer
9. GM 2000 EAC Connecting Cable

Step 1: Attach the grounding cable (7). Remove the ground connection knob (2) and the ground washer (8). Put the ring terminal end of the grounding cable on the grounding stud and replace the ground washer (8) and the ground connection knob (2) securely. The end of the grounding cable with the spring clip is to be attached to the object being sprayed.

Step 2: Attach the GM2000 EAC Connecting Cable (9) to the Socket Outlet (1) on the Power Pack. Secure the cable in place by screwing the nut onto the threads of the power pack cable receptor.

Step 3: Plug power cord into a grounded 110 volt outlet.

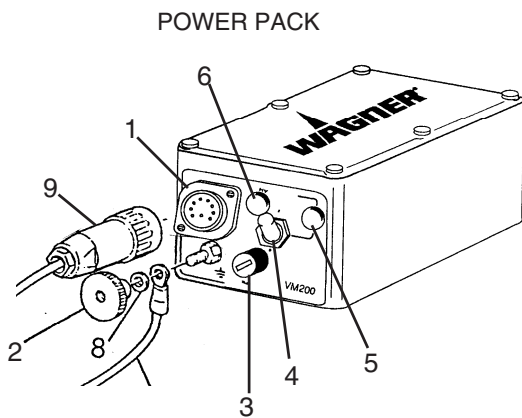

Figure 4



Power cord ground must remain intact. Do not clip off ground pole on plug to fit a non-grounded socket. Static build up will result which may cause an explosion.

OPERATION

1. Set the VM 200 Power Pack Switch to the "I" position (the green light turns on)
2. Adjust the fluid pressure to achieve maximum atomization.
3. If air assist is used, adjust air pressure regulator between 10 & 30 psi.
4. Be sure all items within the spray area are well grounded — Refer back to Warnings — Electrostatic arcing may cause fire/explosion.
5. Test spray pattern and finish on a sample surface. Keep the spray 8 - 12 inches away from the work surface. Readjust fluid and/or air pressure to achieve the optimum atomization and spray pattern.
6. Use the Air Adjustment Knob (located at rear of the spray gun) to control the volume of air. For additional fine tuning rotate tip nut. (Round tip only).
7. For best results, move the entire arm while spraying, not just the wrist.
8. When Power Pack is turned on and the trigger on the spray gun is pulled, both the green light and the red light will be lit. The red light indicates the high voltage is on.
9. The electrostatic On/Off Switch is to be turned off when spraying into corners. With this switch in the "Off" position, the red light on the Power Pack will not be lit. (If the red light is lit with the electrostatic switch in the "Off" position, DO NOT USE - TAKE TO AN AUTHORIZED SERVICE CENTER FOR REPAIR.)
10. Lock the trigger on the spray gun after each use by turning the trigger lock knob (located at the rear of the spray gun) all the way to the right until it stops.

NOTE: The GM2000 EAC spray gun has a two-stage trigger:

1. Pulling the trigger part way - Only the air is on.
2. Pulling the trigger all the way - Both air and fluid are on.

CLEAN UP



WHEN CLEANING THE ELECTROSTATIC SYSTEM, THESE SAFETY PROCEDURES MUST BE FOLLOWED. FAILURE TO FOLLOW THESE PROCEDURES MAY RESULT IN AN EXPLOSION/FIRE.

- Turn power pack to the “OFF” position and unplug from power source before starting to clean.
- Be certain that gun, cable, and power pack are free of all paint spots and cleaning agent residue.
- Exhaust and fresh air introduction must be maintained during the clean up operation.
- Keep cleaning solvents in approved safety containers and only in minimum quantities.
- All personnel and cleaning equipment, including container used in cleaning operation, must be grounded.
- **DO NOT** turn on the VM200 power pack until the cleaning operation has been completed, all cleaning materials have been removed from spray area, and spray area is free of any vapors produced by the cleaning operation.
- If defects in the equipment are found , **DO NOT** use until repairs are completed.



- Clean equipment immediately after use.
 - **NEVER IMMERSE SPRAY GUN IN ANY FLUID AT ANY TIME.**
 - Flush out fluid passages with a cleaning solvent compatible with the coating material being sprayed after each use.
1. **Be sure the VM200 Power Pack is turned off and unplugged from the power source.**
 2. **Check the coating manufacturer’s recommendation for a compatible cleaning solvent.**

NOTE

- **The fluid passages of the spray gun should be cleaned while cleaning the fluid hose and fluid pump, following instructions, provided with the fluid pump.**
- **Clean the spray tip and air cap by removing from spray gun, rinsing in solvent, drying and replacing on spray gun.**

TIP CHANGE

CHANGING THE ROUND SPRAY TIP (OPTIONAL):

1. Screw out spray tip (B) with tip wrench (A). (See Fig.5)
2. Attach desired spray tip and tighten with tip wrench.

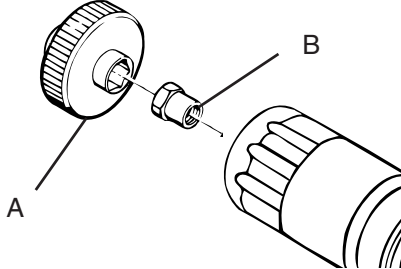

Figure 5

CHANGING THE ROUND NOZZLE BODY

- To remove the tip body (D) place the tip body removal tool on the tip security lever (E) fig. 6A. Squeeze and hold as shown in fig. 6B while unscrewing the tip body.
- Screw out spray tip (B) using the tip spanner and remove diffuser (C) fig 6C.
- Carefully handle the carbide spray tip; avoid cleaning with sharp-edged metal objects.

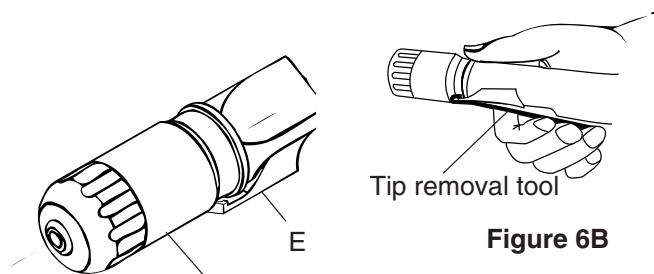

Figure 6B

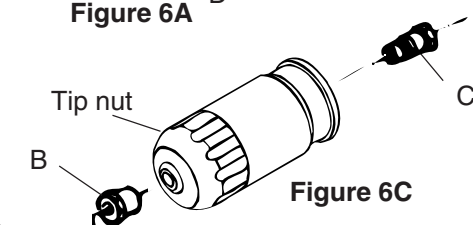

Figure 6C

- Assemble in reverse order.
- Mount tip body (D) and tighten by hand. (Do not use tip removal tool).
- When adjusting tip nut leave a gap for atomizing air between the air cap and tip body.

ASSEMBLY OF FLAT SPRAY TIP

If the round nozzle body is attached: Fig. 7.

- Remove tip body (D) from the spray gun body (F). Using the procedure described in changing the round nozzle body.

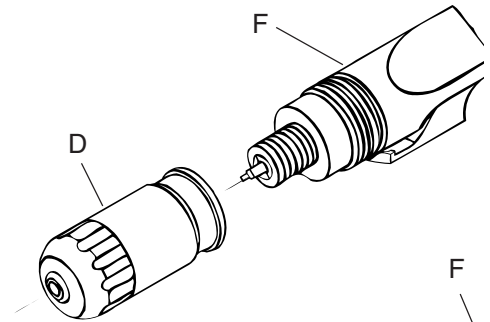

Figure 7

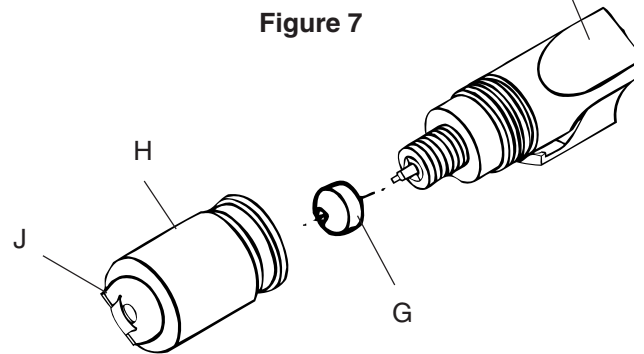

Figure 8

- Mount tip (G) on paint channel of spray gun body (F). See Fig.8.
- Place air cap (H) on tip (G) fitting lugs of air cap into grooves of tip insert.
- Mount air cap (H) onto spray gun body until past the tip security lever.
- Adjust desired air jet level by means of air cap horns (J) and tighten air cap.

ALL PARTS NEEDED FOR THE FLAT TIP MUST BE PURCHASED SEPARATELY. SEE PAGE 18 FOR PART NUMBERS AND ORDERING INFORMATION.

CLEANING OF THE FLAT SPRAY TIP

- Remove air cap (H). (See Fig. 8)
- Remove flat spray tip (G) and clean it.
- Carefully handle the carbide flat spray tip (G); avoid cleaning with sharp-edged metal objects.

MAINTENANCE



Turn off Power Pack and unplug from power source. Relieve pressure to the Spray Gun, Lockout trigger and turn off supply pump and air supply before cleaning or replacing filters, tips, or any other parts failure to follow these procedures may result in fire, explosion or injection injury.

FILTER REPLACEMENT AND CLEANING.

1. Disconnect material hose at fitting (1) Fig 11. Hold material connecting tube with the universal spanner wrench at surface (A).
2. Disconnect union nut (4). Do not allow locking nut (5) to rotate while disconnecting union nut.
3. Unscrew red filter screw. Fig. 9
4. Slip filter cylinder(6) from filter screw.
5. Rinse or replace filter cylinder, (7).
6. Assemble in reverse order.

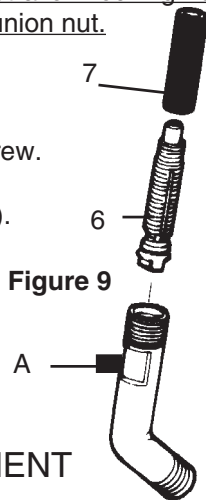

Figure 9

FRONT PACKING ADJUSTMENT

1. If there is evidence of material leakage past the front seal (10) lightly tighten the packing nut (11) with the universal wrench. Fig. 10

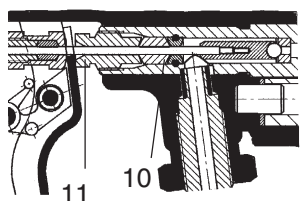

Figure 10

VALVE SEAL REPLACEMENT

To replace valve seals you must remove the entire valve rod.

1. Actuate trigger (3) and unscrew trigger lock knob (2), remove the compression spring. Fig. 11
2. Remove screws holding trigger assembly in place and remove trigger (3). Fig. 11
3. Unscrew seal screw (11/C) from gun body. Fig. 12
4. Carefully remove complete valve rod by pulling end of rod (12). Fig. 12
5. Hold the rod valve using the universal spanner at surface (F) and using a pliers turn the valve seal (8/B) and remove. Fig. 12
6. Remove compression ring (9) and front seal (10). Fig.12
7. To remove push rod cap (14) hold universal spanner at surface (E) and unscrew at surface (D). Fig.12
8. Replace compression ring with O-Ring (9), front seal (12), rear seal (11) and if necessary push rod seal (15) and O-Ring (16) of the air valve . Fig. 12
9. Assemble in reverse order.

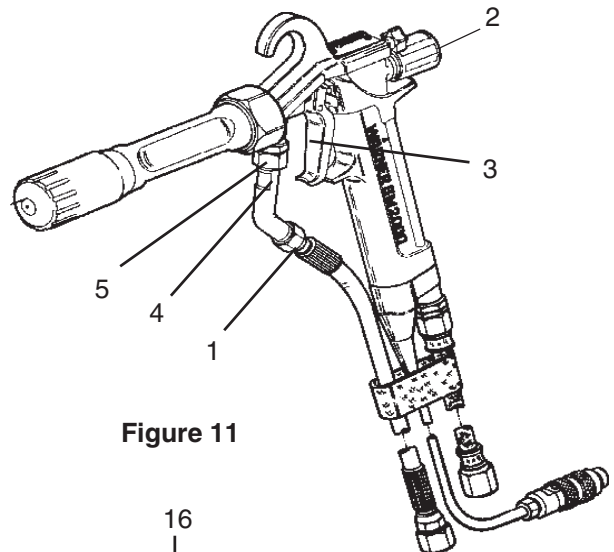

Figure 11

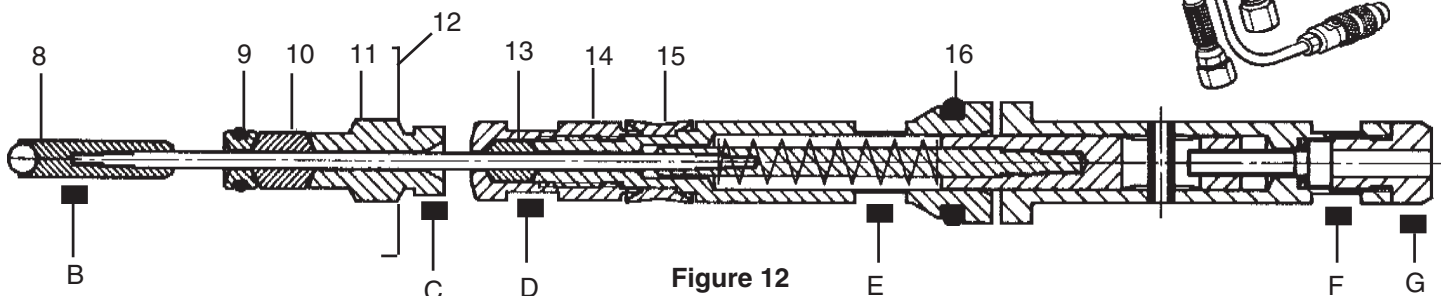

Figure 12

TROUBLESHOOTING

Problem	Cause	Solution
<ul style="list-style-type: none"> • No green light on Power Pack 	<ul style="list-style-type: none"> • Dead outlet. • Fuse blown. • Not plugged in. • Faulty circuit board. 	<ul style="list-style-type: none"> • Live outlet. • Replace fuse. • Plug in. • Take to Authorized Service Center.
<ul style="list-style-type: none"> • Gun on-off switch performing opposite. 	<ul style="list-style-type: none"> • Defective switch. 	<ul style="list-style-type: none"> • Take to Authorized Service Center.
<ul style="list-style-type: none"> • No red light on Power Pack. 	<ul style="list-style-type: none"> • Cable from gun to Power Pack loose or not connected. • Cable from gun to Power Pack defective. • Blown fuse. • If the trigger on the gun is pressed and the above causes have been checked and remedied and there is still no high voltage, then the high voltage generator or Power Pack need service. 	<ul style="list-style-type: none"> • Tighten power cable. • Replace power cable. • Check fuse; replace if necessary. • Take to Authorized Service Center
<ul style="list-style-type: none"> • Spray pattern not even; unsymmetrical or poor atomization. 	<ul style="list-style-type: none"> • Plugged spray tip. • Worn or faulty tip. • Paint too thick. • Uneven air distribution at tip nut. 	<ul style="list-style-type: none"> • Clean tip. • Replace tip. • Thin paint. • Clean all air passages.
<ul style="list-style-type: none"> • Spray pattern is correct, but there is no wraparound. 	<ul style="list-style-type: none"> • Object not grounded. • Cable not fitted properly. • Cable faulty. • High voltage generator • Power Pack is turned off. • Gun on/off switch is off. • Fluid pressure too high. • Air pressure too high. • Electrode dirty or damaged. 	<ul style="list-style-type: none"> • Check ground. • Check connection. • Replace cable. • Replace. • Turn on. • Turn on. • Reduce fluid pressure. • Reduce air pressure. • Clean or replace.

TROUBLESHOOTING

Problem	Cause	Solution
<ul style="list-style-type: none"> • Air leaking at tip without pulling trigger. 	<ul style="list-style-type: none"> • Air valve is faulty. 	<ul style="list-style-type: none"> • Replace air valve.
<ul style="list-style-type: none"> • Air leaks between gun body and gun barrel. 	<ul style="list-style-type: none"> • Gun Barrel Nut. 	<ul style="list-style-type: none"> • Tighten nut.
<ul style="list-style-type: none"> • No air at tip when trigger is pulled. 	<ul style="list-style-type: none"> • Air hose not connected. • No air supply • Wrong tip body fitted • Round tip nut screwed down too hard. • Air channels in tip body or cascade blocked 	<ul style="list-style-type: none"> • Connect air hose • Check air supply • Fit correct EAC tip body • Unscrew nut slightly • Unblock air channels as necessary or take to authorized service center
<ul style="list-style-type: none"> • Material leaks at front or rear packings. 	<ul style="list-style-type: none"> • Packings not tight enough. • Packing faulty. 	<ul style="list-style-type: none"> • Lightly tighten packing nuts. • Replace packings as necessary.
<ul style="list-style-type: none"> • Material leaks at tip without pulling trigger. 	<ul style="list-style-type: none"> • Valve stem and valve seat dirty or faulty. 	<ul style="list-style-type: none"> • Clean or replace as necessary
<ul style="list-style-type: none"> • No material at tip when trigger is pulled. 	<ul style="list-style-type: none"> • No material supply • Gun filter blocked or fitted upside-down. • Tip plugged. 	<ul style="list-style-type: none"> • Check supply pressure • Replace filter, or mount it correctly. • Unplug tip.
<ul style="list-style-type: none"> • Material leaks at joint between gun body and gun barrel when trigger is pulled. 	<ul style="list-style-type: none"> • Gun barrel nut loose • Material channel faulty 	<ul style="list-style-type: none"> • Tighten nut. DO NOT overtighten. • Take to Authorized Service Center.

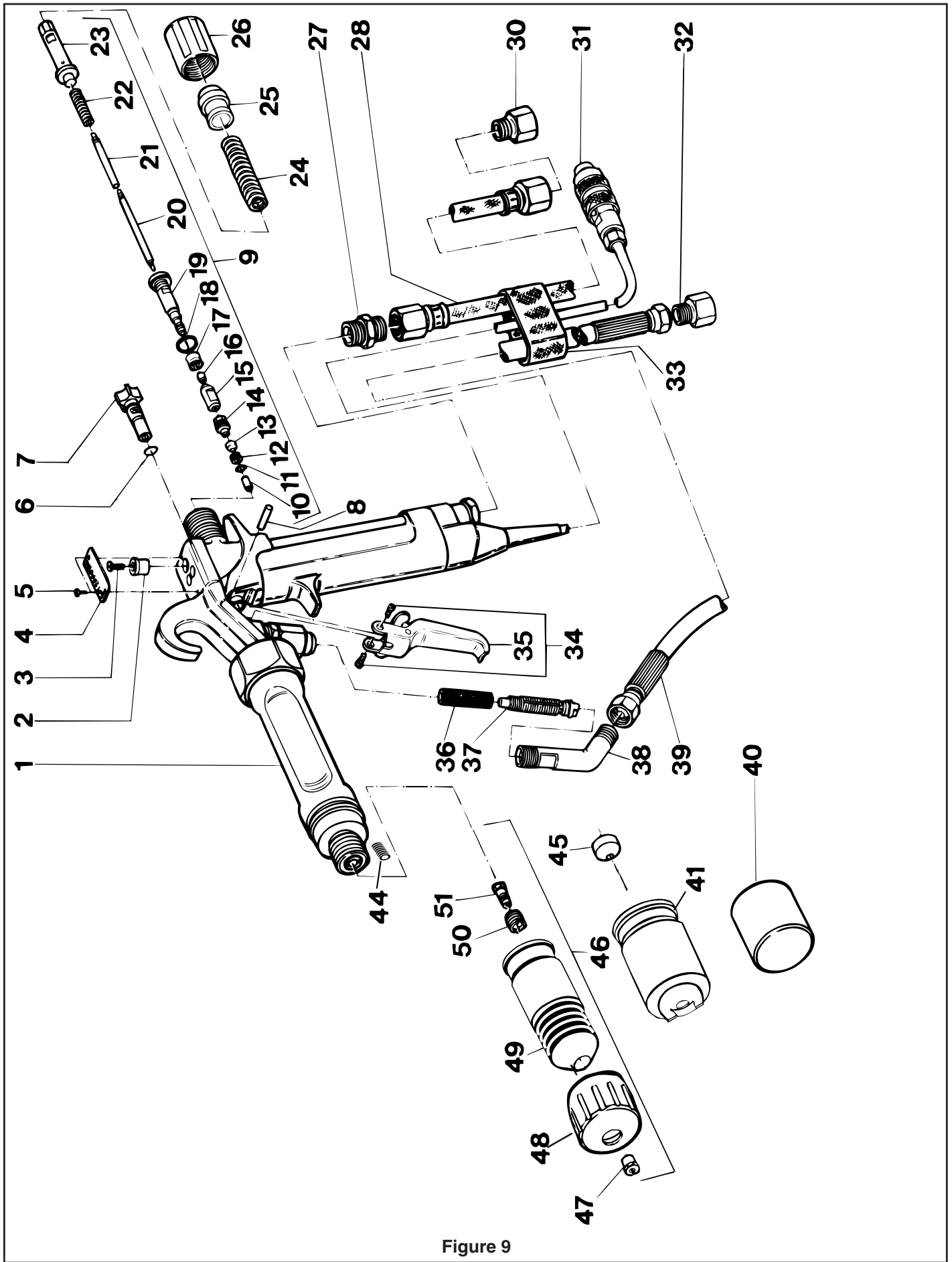

Figure 9

GM 2000 EAC

Item	Description	Part Number
1	Spray gun barrel	0179500
2	Bushing	0128336
3	Screw countersunk	0179354
4	Type plate	9900962
5	Screw flathead	9900810
6	O-ring	9971003
7	Knob, Air Adjustment	0179416
8	Trigger sleeve	0179396
9	Valve rod complete	0179254
10	Valve sealing element	0179236
11	O-ring	9971182
12	Compression ring	0179343
13	Seal	0179341
14	Sealing screw	0179342
15	Push-rod cap	0179340
16	Seal	0179395
17	Push-rod seal	0179339
18	O-ring	9971372
19	Valve push-rod	0179337
20	Valve rod	0179335
21	Valve rod spring guide	0179394
22	Compression spring	9994247
23	Adjusting element	0179253
24	Compression spring	9994248
25	Compressing element EAC	0179488
26	Locking nut	0179356
27	Double socket	9994627
28	Air hose	0128510
30	Connection adapter BSP 1/4	9983226
31	Connecting cable	Call Factory
32	Connecting adapter M16x1.5	0097201
33	Hose cover	0179248
34	Flat-head screw*	9900808
35	Trigger*	0179219
36	Cylindrical filter*	9995611
37	Filter screw	0179383
38	Material connector	0179241
39	High pressure hose	9984482
40	Protecting cap EAC	0179482
41	Nozzle EAC, flat	0179678
44	Compression spring	9994269
45	Tip insert EAC, flat	See Nozzle List
46	Nozzle EACR 2000	0179679
47	Tip insert EACR 15, standard	0132724
48	Air cap EACR	0179536
49	Tip body, EACR	0179664
50	Locking screw	0132351
51	Diffuser with sealing nipple	0132516
52	Wrench Universal	0179901
53	Glove	9994682
54	Tip Wrench	0179902
55	Tip body removal tool	0179963

Flat Tip

Round Tip

Part Number	Tip Marking	Orifice Size (Inch)	Fan Width
0128550	9/15	.009	15°
0128216	9/20	.009	20°
0128552	11/15	.011	15°
0128217	11/20	.011	20°
0128201	11/50	.011	50°
0128554	13/15	.013	15°
0128218	13/20	.013	20°
0128212	13/50	.013	50°
0128556	15/15	.015	15°
0128219	15/20	.015	20°
0128213	15/50	.015	50°
0128215	18/50	.018	50°
0128565	21/20	.021	20°
0128559	21/50	.021	50°
0128561	26/50	.026	50°
0128562	31/50	.031	50°
0128563	36/50	.036	50°

Part Number	Tip Marking	Orifice	Volume oz./Min	@ 250 PSI G.P.M.
		Size .001 (Inch)		
0132720	R11/2	.0066	2.28	.0178
0132721	R12/2	.0080	3.07	.0240
0132722	R13/2	.0092	3.74	.0292
0132723	R14/2	.0104	4.77	.0373
0132724	R15/2	.0110	5.29	.0413
0132725	R16/2	.0115	6.02	.0470
0132726	R17/2	.0121	6.72	.0525
0132727	R18/2	.0126	7.30	.0570
0132728	R19/2	.0132	8.32	.0650
0132729	R20/2	.0139	9.22	.0720
0132730	R21/2	.0145	9.92	.0775
0132731	R22/2	.0151	10.75	.0840

Accessories

0088154 Fluid Pressure Gauge

LIMITED WARRANTY ELECTROSTATIC PAINT SPRAY EQUIPMENT

To validate this warranty, the completed registration card must be mailed within one week of the date of purchase to Wagner Spray Tech Corporation.

Wagner Spray Tech Corporation extends to the original purchaser of its electrostatic paint spray equipment a one year warranty against defects in material or workmanship provided that the equipment is installed and operated in accordance with the recommendations and instructions of Wagner Spray Tech Corporation. Wagner Spray Tech will repair or replace, at its option, defective parts without charge if such parts are returned with transportation charges prepaid to the nearest authorized service agency or to Wagner Spray Tech Corporation, 1770 Fernbrook Lane, Minneapolis, Minnesota.

This warranty does not cover:

1. Equipment and accessories supplied to Wagner Spray Tech Corporation by other manufacturers including hose are covered by the express warranties of the original manufacturers. Wagner Spray Tech Corporation will provide the purchaser with reasonable information and assistance in making claims to the original manufacturers under their warranty.
2. Normal wear and/or defects caused by or related to abrasion, corrosion, abuse, negligence, accident faulty installation or tampering in a manner which impairs normal operation.
3. Transportation costs and other incidental, direct, special or consequential damages or loss.

Any implied warranty of merchantability or fitness for a particular purpose on Wagner Spray Tech Corporation's spray equipment is limited in duration to the duration of this warranty.

Some states do not allow the exclusion of incidental or consequential damages, or allow limitations on how long an implied warranty lasts, so the above limitations or exclusion may not apply to you. This warranty gives you specific legal rights, and you may also have other rights which vary from state to state.

Copyright 1989 by Wagner Spray Tech Corporation

ALL RIGHTS RESERVED

U.S. PATENT 3,843,052



Wagner Spray Tech Corporation
1770 Fernbrook Lane
Minneapolis, Minnesota 55447
Telephone (612) 553-7000

PRINTED IN U.S.A.

Free Manuals Download Website

<http://myh66.com>

<http://usermanuals.us>

<http://www.somanuals.com>

<http://www.4manuals.cc>

<http://www.manual-lib.com>

<http://www.404manual.com>

<http://www.luxmanual.com>

<http://aubethermostatmanual.com>

Golf course search by state

<http://golfingnear.com>

Email search by domain

<http://emailbydomain.com>

Auto manuals search

<http://auto.somanuals.com>

TV manuals search

<http://tv.somanuals.com>