

ED655 Plus Airless Pump

Owner's Manual



Model Number 0508090

SprayTECH[®]
THE DEPENDABLE CHOICE™

SprayTECH
✉ 1770 Fernbrook Lane
Minneapolis, MN 55447

Technical Assistance: 1-800-292-4637
Order Entry: 1-800-443-4500
Fax: 1-800-525-9501

www.spraytechinc.com

Printed in the U. S. A.

0505 © 2005 SprayTECH. All rights reserved. Form No. 0508278A

Table of Contents

Safety Precautions	2
Grounding Instructions	3
General Description	4
Specifications	4
Preparing to Paint	4
Attaching the Tip to the Gun	4
Checking the Outlet Valve (optional)	4
Attaching the Paint Hose	5
Pressure Relief Procedure	5
Priming	5
Preparing to Prime	5
Mounting the Paint Hopper	6
Attaching the Return Tube	6
Priming the Pump	6
Spraying	7
Spraying Technique	7
Practice	7
Cleanup	8
Overnight Storage	8
Long-Term Storage	8
Maintenance	10
Removing and Cleaning the Inlet Valves	10
Removing and Cleaning the Outlet Valve	10
Cleaning the Hopper Screen	10
Troubleshooting	11
Parts Listings	16
Main Assembly	16
Diaphragm Pump	17
Pump Head Assembly	18
Hopper Assembly	18
Limited Warranty	20

Safety Precautions

This manual contains information which must be read and understood before using the equipment. When you come to an area which has one of the following symbols, pay particular attention and make certain to heed the safeguard.



This symbol indicates a potential hazard which may cause serious injury or loss of life. Important safety information will follow.



This symbol indicates a potential hazard to you or to the equipment. Important information that tells how to prevent damage to the equipment or how to avoid causes of minor injuries will follow.

NOTE: Notes give important information which should be given special attention.



This unit is provided with a thermally protected automatic reset. If an overload occurs the thermally protected automatic reset disconnects the motor from the power supply.

- The motor will restart without warning when the protector automatically resets.
- Always disconnect the motor from the power supply before working on the equipment.
- When the thermally protected automatic reset disconnects the motor from the power supply, relieve pressure by turning the priming valve to PRIME.
- Turn the ON/OFF switch to OFF.

NOTE: The cause of the overload should be corrected before restarting. See TROUBLESHOOTING.



IMPORTANT SAFETY INSTRUCTIONS

- A. SAVE THESE INSTRUCTIONS – To reduce the risks of fire or explosion, electrical shock, and the injury to persons, read and understand all instructions included in this manual. Be familiar with the controls and the proper usage of the equipment.**
- B. WARNING – To reduce the risk of fire or explosion:**
1. Do not spray flammable or combustible materials near an open flame, pilot lights or sources of ignition such as hot objects, cigarettes, motors, electrical equipment and electrical appliances. Avoid creating sparks from connecting and disconnecting power cords.
 2. For units intended for use with only water-based materials — Do not spray or clean with flammable liquids. For use with water-based liquids only.
 3. For units intended for use with only water-based or mineral spirit-type materials with a minimum flash point of 21°C (69.8°F) — Do not spray or clean with liquids having a flash point of less than 21°C (69.8°F). Flash point is the temperature at which a fluid can produce enough vapor to ignite.
 4. Paint or solvent flowing through the equipment is able to result in static electricity. Static electricity creates a risk of fire or explosion in the presence of paint or solvent fumes. All parts of the spray system, including the pump, hose assembly, spray gun and objects in and around the spray area shall be properly grounded to protect against static discharge and sparks. Use only conductive or grounded high-pressure airless paint sprayer hoses specified by the manufacturer.
 5. Verify that all containers and collection systems are grounded to prevent static discharge.
 6. Connect to a grounded outlet and use grounded extension cords. Do not use a 3 to 2 adapter.
 7. Do not use a paint or solvent containing halogenated hydrocarbons. Such as chlorine, bleach mildewcide, methylene chloride and trichloroethane. They are not compatible with aluminum. Contact the coating supplier about compatibility of material with aluminum.
 8. Keep spray area well ventilated. Keep a good supply of fresh air moving through the area to keep the air within the spray area free from accumulation of flammable vapors. Keep pump assembly in well ventilated area. Do not spray pump assembly.
 9. Do not smoke in the spray area.
 10. Do not operate light switches, engines, or similar spark producing products in the spray area.
 11. Keep area clean and free of paint or solvent containers, rags, and other flammable materials.
 12. Know the contents of the paint and solvents being sprayed. Read all Material Safety Data Sheets (MSDS) and container labels provided with the paints and solvents. Follow the paint and solvent manufacturer's safety instructions.
 13. Place pump at least 25 feet (7.62 meters) from the spray object in a well ventilated area (add more hose if necessary). Flammable vapors are often heavier than air. Floor area must be extremely well ventilated. The pump contains arcing parts that emit sparks and can ignite vapors.
 14. Plastic can cause static sparks. Never hang plastic to enclose spray area. Do not use plastic drop cloths when spraying flammable material.
 15. Fire extinguisher equipment shall be present and working.

⚠ WARNING

C. WARNING – To reduce the risk of skin injection:

HAZARD:

Injection injury – A high pressure fluid stream produced by this equipment can pierce the skin and underlying tissues, leading to a serious injury and possible amputation. See a physician immediately. DO NOT TREAT AN INJECTION AS A SIMPLE CUT.

1. Do not aim the gun at, or spray any person or animal.
2. Keep hands and other body parts away from the discharge. For example, do not try to stop leaks with any part of the body.
3. Always use the nozzle tip guard. Do not spray without the nozzle tip guard in place.
4. Only use a nozzle tip specified by the manufacturer.
5. Use caution when cleaning and changing nozzle tips. In the case where the nozzle tip clogs while spraying, ALWAYS lock gun trigger, shut pump off, and release all pressure before servicing, cleaning tip or guard, or changing tip. Pressure will not be released by turning off the motor. The PRIME/SPRAY valve handle must be turned to PRIME to relieve the pressure. Refer to PRESSURE RELIEF PROCEDURE described in the pump manual.
6. Do not leave the unit energized or under pressure while unattended. When the unit is not in use, turn off the unit and relieve the pressure in accordance with the manufacturer's instructions.
7. High-pressure spray is able to inject toxins into the body and cause serious bodily injury. In the event that injection occurs, seek medical attention immediately.
8. Check hoses and parts for signs of damage, a leak can inject material into the skin. Inspect hose before each use. Replace any damaged hoses or parts.
9. This system is capable of producing 2800 PSI / 19.3 MPa. Only use replacement parts or accessories that are specified by the manufacturer and that are rated a minimum of 3100 PSI. This includes spray tips, nozzle guards, guns, extensions, fittings, and hose.
10. Always engage the trigger lock when not spraying. Verify the trigger lock is functioning properly.
11. Verify that all connections are secure before operating the unit.
12. Know how to stop the unit and bleed pressure quickly. Be thoroughly familiar with the controls. Pressure will not be released by turning off the motor. The PRIME/SPRAY valve handle must be turned to PRIME to relieve the pressure. Refer to PRESSURE RELIEF PROCEDURE described in the pump manual.
13. Always remove the spray tip before flushing or cleaning the system.

⚠ WARNING

D. WARNING – To reduce the risk of injury:

1. Always wear appropriate gloves, eye protection, clothing and a respirator or mask when painting. Hazardous vapors – Paints, solvents, insecticides, and other materials can be harmful if inhaled or come in contact with body. Vapors can cause severe nausea, fainting or poisoning.
2. Do not operate or spray near children. Keep children away from equipment at all times.
3. Do not overreach or stand on an unstable support. Keep effective footing and balance at all times.
4. Stay alert and watch what you are doing.
5. Do not operate the unit when fatigued or under the influence of drugs or alcohol.

6. Do not kink or over-bend the hose. Airless hose can develop leaks from wear, kinking and abuse. A leak can inject material into the skin.
7. Do not expose the hose to temperatures or pressures in excess of those specified by manufacturer.
8. Do not use the hose as a strength member to pull or lift the equipment.
9. Use lowest possible pressure to flush equipment.
10. Follow all appropriate local, state and national codes governing ventilation, fire prevention and operation.
11. The United States Government Safety Standards have been adopted under the Occupational Safety and Health Act (OSHA). These standards, particularly part 1910 of the General Standards and part 1926 of the Construction Standards should be consulted.
12. Before each use, check all hoses for cuts, leaks, abrasion or bulging of cover. Check for damage or movement of couplings. Immediately replace hose if any of those conditions exist. Never repair a paint hose. Replace with a conductive high-pressure hose.
13. Do not spray outdoors on windy days.
14. Always unplug cord from outlet before working on equipment.

Grounding Instructions

This product must be grounded. In the event of an electrical short circuit, grounding reduces the risk of electric shock by providing an escape wire for the electric current. This product is equipped with a cord having a grounding wire with an appropriate grounding plug. The plug must be plugged into an outlet that is properly installed and grounded in accordance with all local codes and ordinances.

DANGER — Improper installation of the grounding plug can result in a risk of electric shock. If repair or replacement of the cord or plug is necessary, do not connect the green grounding wire to either flat blade terminal. The wire with insulation having a green outer surface with or without yellow stripes is the grounding wire and must be connected to the grounding pin.

Check with a qualified electrician or serviceman if the grounding instructions are not completely understood, or if you are in doubt as to whether the product is properly grounded. Do not modify the plug provided. If the plug will not fit the outlet, have the proper outlet installed by a qualified electrician.

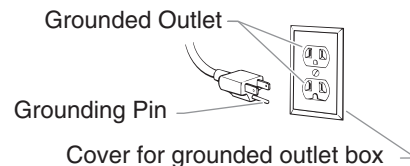

⚠ CAUTION

Use only a 3-wire extension cord that has a 3-blade grounding plug and a 3-slot receptacle that will accept the plug on the product. Make sure your extension cord is in good condition. When using an extension cord, be sure to use one heavy enough to carry the current your product will draw. An undersized cord will cause a drop in line voltage resulting in loss of power and overheating. A 12 gauge cord is recommended. If an extension cord is to be used outdoors, it must be marked with the suffix W-A after the cord type designation. For example, a designation of SJTW-A would indicate that the cord would be appropriate for outdoor use.

General Description

This high performance airless sprayer is a precision power tool used for spraying many types of materials. Read and follow this instruction manual carefully for proper operating instructions, maintenance and safety information.



Specifications

Weight	27 lbs
Capacity	Up to .35 gallon (1.25 liters) per minute
Power source	Electric motor, totally enclosed, fan cooled
Power requirement.....	15 amp minimum circuit on 115 VAC, 60 Hz current.
Generator	15 amp A/C.
Spraying pressure	Up to 2750 PSI
Capabilities.....	Sprays a variety of oil-based and latex paints, primers, and stains

Preparing to Paint

Attaching the Tip to the Gun

1. Lock the trigger by rotating the trigger lock forward until it stops.

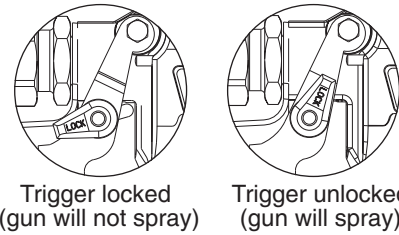

WARNING

POSSIBLE INJECTION HAZARD. Do not spray without the tip guard in place. Never trigger the gun unless the tip is in either the spray or the unclog position. Always engage the gun trigger lock before removing, replacing or cleaning tip.

2. Thread the tip guard onto the gun. Tighten the nut first by hand, then tighten more firmly with a wrench.

NOTE: When attaching the tip guard to the gun, align the tip guard as shown in the figure below, then tighten with a wrench.

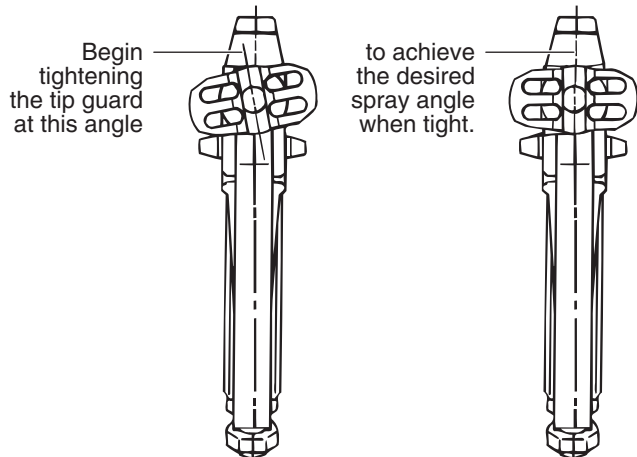

Checking the Outlet Valve (optional)

1. Firmly press the optional pusher valve button on the side of the pump housing to make sure the outlet ball valve moves freely.

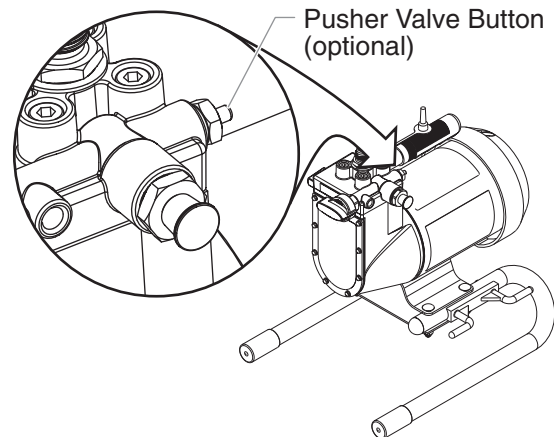

Attaching the Paint Hose

1. Attach the high pressure hose to the paint sprayer. Use a wrench to tighten the paint hose securely.

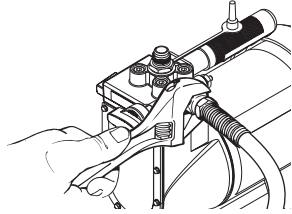

2. Attach the spray gun to the other end of the high pressure hose. Tighten the hose securely to the gun using two wrenches.

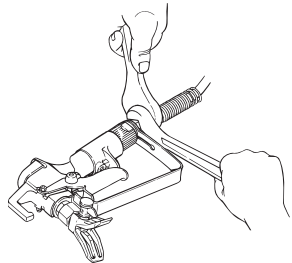

3. Plug the sprayer into a properly grounded outlet or heavy duty grounded extension cord. Do not use more than 100 feet of cord. If you must spray a long distance from a power source, use more paint hose, not more extension cords. Use a minimum size of 16 gauge extension cord for up to 50 feet in length, or 12 to 14 gauge for extension cords between 50 and 100 feet in length.

Pressure Relief Procedure

Follow this procedure after the unit is assembled and before any operation which involves the spray gun such as cleaning and maintenance or changing tips or accessories.

1. Turn the pressure control knob counterclockwise to its lowest setting.

Pressure Control Knob

PRIME/SPRAY Knob

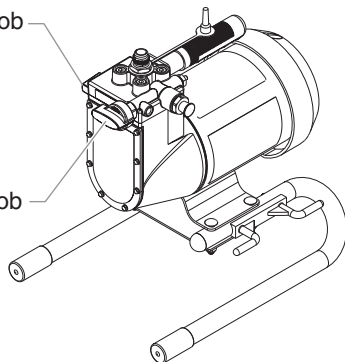

2. Turn the PRIME/SPRAY knob to PRIME.
3. Trigger the gun to remove any pressure which may still be in the hose.
4. Lock the trigger by rotating the trigger lock forward until it stops.

WARNING

Injection hazard. Do not spray without the tip guard in place. NEVER trigger the gun unless the tip is completely turned to either the spray or the unclog position. ALWAYS engage the gun trigger lock before removing, replacing or cleaning tip.

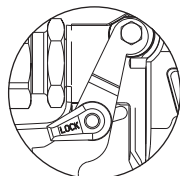

Trigger locked
(gun will not spray)

Priming

Preparing to Prime

1. Fill the inlet valve with water or with a light household oil.

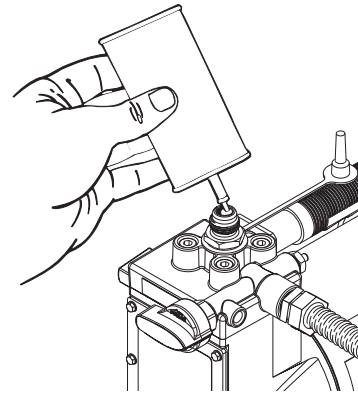

2. Make sure the PRIME/SPRAY knob is set to PRIME and that the pressure control knob is turned counterclockwise to the lowest pressure setting.
3. Turn the motor switch to ON.
4. Increase the pressure by turning the pressure control knob clockwise 1/2 turn.
5. Force the inlet valve to open and close by pushing on it with a screwdriver or the eraser end of a pencil. It should move up and down about 1/16 of an inch. Continue until water or oil is sucked into the sprayer. This will wet the moving parts and break loose any old paint residue.

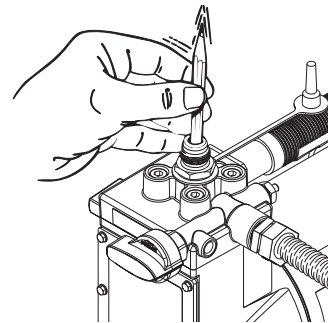

6. Put the palm of your hand over the inlet. Turn the pressure control knob clockwise to its maximum setting. You should feel suction coming from the inlet valve. If you do not, see the section on cleaning and servicing the outlet valve.

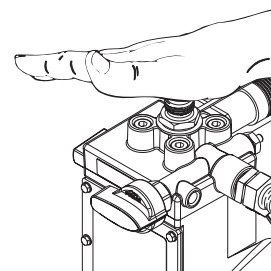

7. Turn the pressure control knob counterclockwise to the minimum pressure setting.
8. Turn the motor switch to OFF.

Mounting the Paint Hopper

1. Align the bottom of the paint hopper with the threaded inlet valve on the paint pump block.
2. Turn the paint hopper clockwise to thread it onto the inlet valve. Continue to turn the paint hopper until it is secure on the inlet valve.

NOTE: Make sure the threads are straight and the hopper turns freely on the inlet valve. Do not cross-thread.

3. Place the filter screen into the bottom of the paint hopper and snap it in position.

Attaching the Return Tube

1. Make sure that the motor switch is turned to OFF.
2. Screw the return tube fitting found in the literature set into the return tube port on the side of the pump.

NOTE: Do not over-tighten. Hand-tighten only. Some threads will be visible even when fully tightened.

3. Place the straight end of the return tube into the return tube fitting.

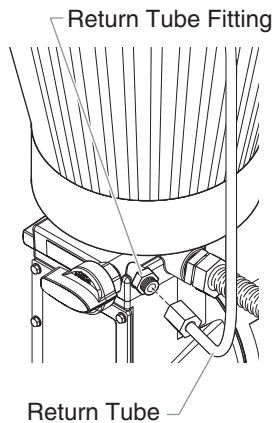

4. Thread the nut on the return tube onto the return tube fitting and tighten until the return tube is secure.
5. Place the hook end of the return tube into the hole in the paint hopper cover.

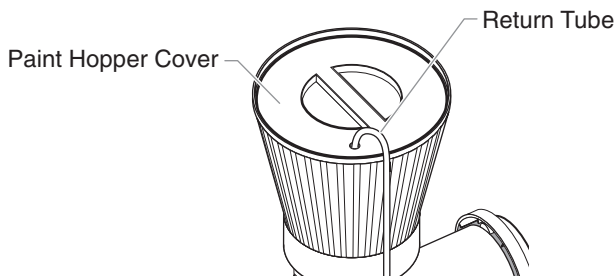

Priming the Pump

1. Turn the pressure control knob counterclockwise to its lowest pressure setting.

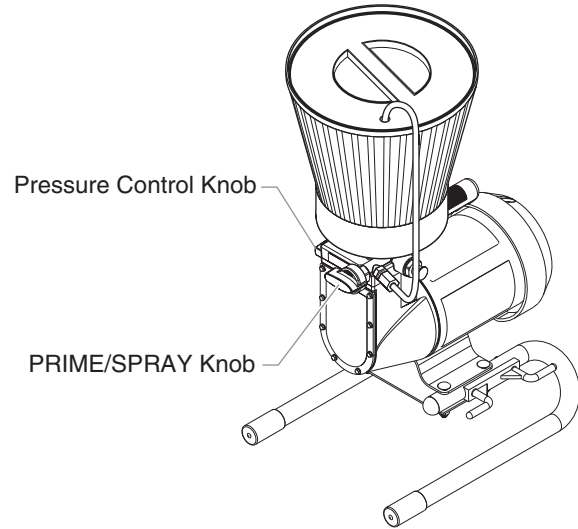

2. Remove the paint hopper cover and fill the paint hopper with material.
3. Turn the PRIME/SPRAY knob to PRIME.
4. Turn the motor switch to ON.
5. Turn the pressure control knob clockwise to between half and full pressure. Let the unit prime 1 to 2 minutes after material begins to flow through the return tube.

CAUTION

Always reduce the pressure to zero before changing the position of the PRIME/SPRAY knob. Failure to do so may cause damage to the paint pump diaphragm.

CAUTION

If the pressure control knob is reduced to zero and the PRIME/SPRAY knob is still on SPRAY while the sprayer is operating, there will be high pressure in the hose and spray gun until the PRIME/SPRAY knob is turned to PRIME or until the spray gun is triggered to relieve the pressure.

Spraying

Spraying Technique

The key to a good paint job is an even coating over the entire surface. This is done by using even strokes. Keep your arm moving at a constant speed and keep the spray gun at a constant distance from the surface. The best spraying distance is 10 to 12 inches between the spray tip and the surface.

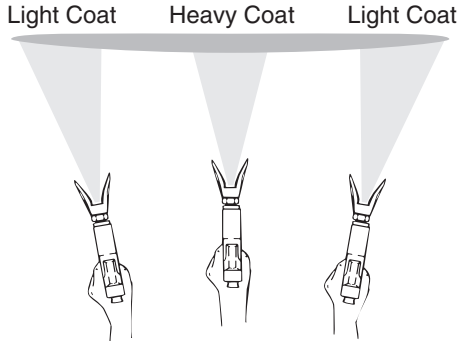

Do not flex wrist while spraying.

Keep the spray gun at right angles to the surface. This means moving your entire arm back and forth rather than just flexing your wrist.

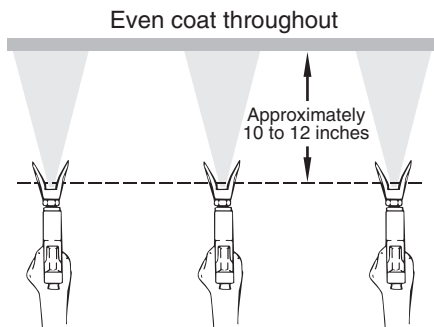

Keep stroke smooth and at an even speed.

Keep the spray gun perpendicular to the surface, otherwise one end of the pattern will be thicker than the other.

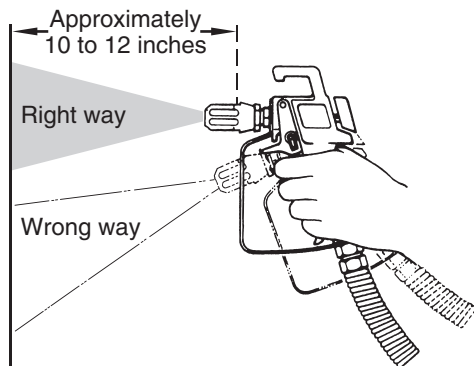

The spray gun should be triggered by turning it on and off with each stroke. This will save paint and avoid paint buildup at the end of the stroke. Do not trigger the gun during the middle of a stroke. This will result in an uneven spray and splotchy coverage.

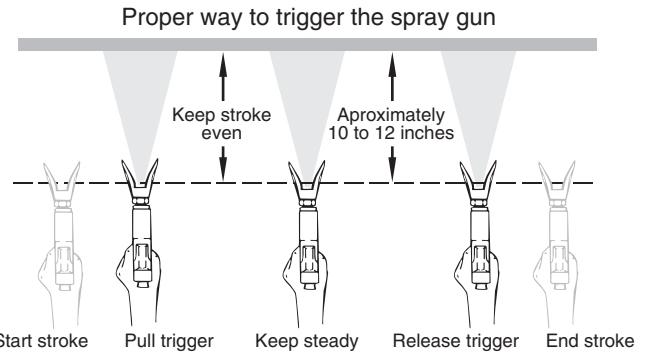

Overlap each stroke by about 30%. This will ensure an even coating.

When you stop painting, lock the gun trigger lock, turn the pressure control knob counterclockwise to its lowest setting and set the PRIME/SPRAY knob to PRIME. Turn the motor switch to OFF and unplug the sprayer.

If you expect to be gone more than 1 hour, follow the short term clean up procedure described in the CLEANUP section of this manual.

Practice

1. Be sure that the paint hose is free of kinks and clear of objects with sharp cutting edges.
2. Turn the pressure control knob counterclockwise to its lowest setting.

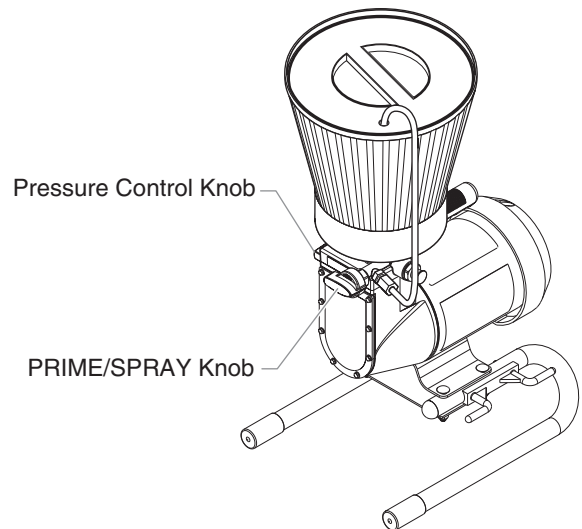

3. Turn the PRIME/SPRAY knob to SPRAY.
4. Turn the pressure control knob clockwise to its highest setting. The paint hose should stiffen as paint begins to flow through it.

5. Unlock the gun trigger lock by turning the switch so that it is parallel to the handle.
6. Trigger the spray gun to bleed air out of the hose.
7. When paint reaches the spray tip, spray a test area to check the spray pattern.

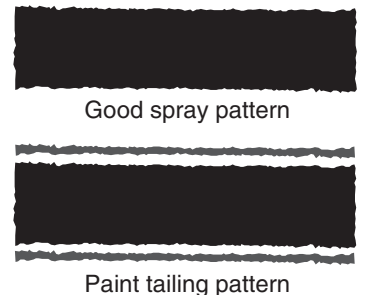

8. Use the lowest pressure setting necessary to get a good spray pattern. If the pressure is set too high, the spray pattern will be too light. If the pressure is set too low, tailing will appear or the paint will spatter out in gobs rather than in a fine spray.

Cleanup

Overnight Storage

Shutdown

1. Turn the pressure control knob counterclockwise to the minimum setting.
2. Turn the PRIME/SPRAY knob to PRIME to release system pressure.
3. Trigger the gun to remove any pressure that may still be in the hose.
4. Lock the trigger by rotating the trigger lock forward until it stops.
5. Turn the motor switch to OFF and unplug the sprayer.
6. For latex materials only, pour 1/2 cup water slowly on the top of the paint to prevent the paint from drying. For other materials, seal the paint hopper with the hopper cover keeping the return tube in the paint.

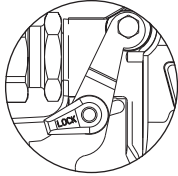

Trigger locked
(gun will not spray)

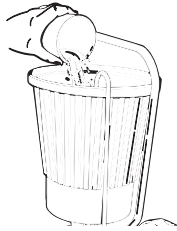

7. Wrap the spray gun assembly in a damp cloth and place it in a plastic bag. Seal the bag shut.



8. Place the sprayer in a safe place out of the sun for short-term storage.

Startup

1. Remove the gun from the plastic bag.
2. Stir the water into the paint for latex materials. Remove the hopper cover from the paint hopper and stir the paint for all other materials.



3. Check to be sure that the PRIME/SPRAY knob is set to PRIME and that the pressure is completely reduced.
4. Plug sprayer in and turn the motor switch to ON.
5. After the sprayer is primed, turn the PRIME/SPRAY knob to SPRAY and gradually turn the pressure control knob clockwise to increase the pressure.
6. Test the sprayer on a practice piece and begin spraying.

Long-Term Storage

⚠ WARNING

Do not allow paint to build up on the motor or the motor will overheat. Do not allow flammable solvents to come in contact with the motor or they could ignite.

NOTE: You will need a bucket, cleaning solution, a toothbrush, a wrench and cleaning rags.

NOTE: If spraying with latex paint, use warm soapy water for cleaning. If using oil or alkyd-based paints, use mineral spirits or paint thinner.

⚠ CAUTION

Do not use mineral spirits or paint thinner on latex paint, or the mixture will turn into a jelly-like substance which is difficult to remove.

Clearing the Paint Hopper

1. Lock the gun trigger by rotating the trigger lock forward until it stops.
2. Turn the pressure control knob counterclockwise to the minimum setting.
3. Turn the PRIME/SPRAY knob to PRIME.
4. Turn the motor switch to OFF.
5. Direct the return tube into the original paint bucket.
6. Turn the motor switch to ON.
7. Turn the pressure control knob to 1/2 maximum pressure. This will draw the remaining paint in the paint hopper through the pump, up the return tube, and into the paint bucket.
8. Turn the pressure control knob counterclockwise to the minimum pressure setting.
9. Trigger the gun to relieve pressure and lock the gun.
10. Remove the spray tip and guard and place them into a container of water or appropriate solvent for the type of material with which you are painting.
11. Fill the paint hopper with water or an appropriate solvent for the type of material with which you are painting.
12. Direct the return tube into a waste bucket.
13. Increase the pressure to 1/2 the maximum pressure. Let the water or solvent circulate for 2-3 minutes to flush paint out of the pump, the paint hopper, and the return tube.

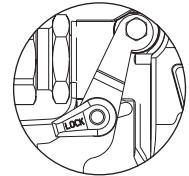

Trigger locked
(gun will not spray)

Clearing the Paint Hose

1. To save paint left in the hose, release the gun trigger lock and carefully trigger the gun with the spray tip removed against the inside of the paint container.

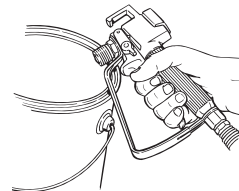

2. Turn the pressure control knob counterclockwise to the minimum pressure setting.
3. Turn the PRIME/SPRAY knob to SPRAY.

4. Turn the pressure control knob slowly until paint starts to flow into the bucket. As soon as the water or solvent starts to come into the bucket, release the trigger.
5. Change to clean water or solvent, point the gun to the side of the waste bucket, and continue circulating for another 5 minutes to thoroughly clean the hose, pump and spray gun.
6. Turn the pressure control knob counterclockwise to its lowest setting.
7. Turn the PRIME/SPRAY knob to PRIME.
8. Trigger the gun to remove any pressure which may still be in the hose.
9. Lock the gun trigger by rotating the trigger lock forward until it stops.
10. Turn the motor switch to OFF.

Clearing the Gun

1. Remove the spray gun from the paint hose using two adjustable wrenches.
2. Remove the filter housing from the gun. Place the gun and the filter assembly into a container of water or solvent to soak.
3. Cover the paint container and set it aside.
4. Clean the spray tip and gun filter with a soft brush.
5. Reassemble the gun and filter. Assemble the spray tip in the cleaning position with the arrow pointing to the back of the gun.



6. Attach the paint hose to the gun and tighten using two wrenches.

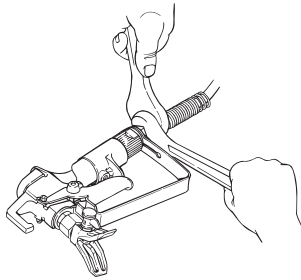

7. Turn the motor switch to ON.
8. Unlock gun trigger by turning the gun trigger lock so that it is parallel to the gun handle.
9. Turn the PRIME/SPRAY knob to SPRAY and point the gun to the side of the waste bucket.

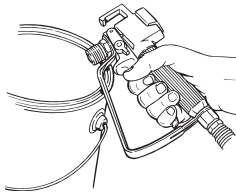

10. Trigger the gun and gradually turn the pressure control knob clockwise to 1/2 pressure. Continue to trigger the gun for approximately 30 seconds.
11. Turn the pressure control knob counterclockwise to its lowest setting.
12. Turn the PRIME/SPRAY knob to PRIME.

13. Trigger the gun to remove any pressure which may still be in the hose.
14. Lock the gun trigger by rotating the trigger lock forward until it stops.
15. Turn the motor switch to OFF.

Final Cleanup

1. Remove the tip assembly.
2. Turn the motor to ON.
3. Turn the PRIME/SPRAY knob to SPRAY.
4. Turn the pressure control knob clockwise to 1/2 power.
5. Trigger the gun into the cleaning bucket until the hopper is empty.
6. Refill the hopper and continue flushing the system until the solution coming out of the gun appears clean.
7. Lock the gun and turn the pressure control knob counterclockwise to its lowest setting.
8. Turn the PRIME/SPRAY knob to PRIME.
9. Remove the hopper from the inlet valve.
10. Clean the threads of the inlet valve with a damp cloth.
11. Fill the inlet valve with a light household oil.

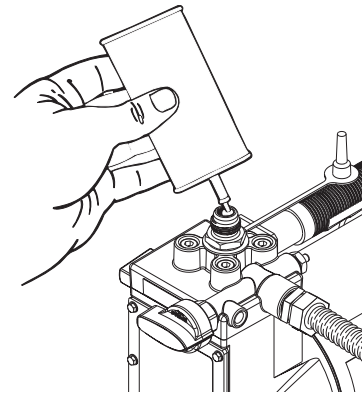

12. Turn the PRIME/SPRAY knob to SPRAY to distribute the oil.

NOTE: Proper cleaning and oiling of the pump after use are the most important steps you can take to insure proper operation after storage.

13. Turn the pressure control knob counterclockwise to its lowest setting.
14. Turn the PRIME/SPRAY knob to PRIME.
15. Trigger the gun to remove any pressure that may still be in the hose.
16. Lock the gun trigger by rotating the trigger lock forward until it stops..
17. Turn the motor switch to OFF.
18. Remove the hopper filter and clean in clean water or the appropriate solvent. Use a soft brush.
19. Return the hopper filter to its position in the hopper and replace the hopper on the inlet valve.
20. Wipe the entire unit, hose and gun with a damp cloth to remove accumulated paint.

Maintenance

Follow these procedures when encountering problems indicated in the troubleshooting section.

Removing and Cleaning the Inlet Valves

1. Be certain that the sprayer is off.
2. Remove the inlet valve assembly using a 27 millimeter socket or box end wrench.

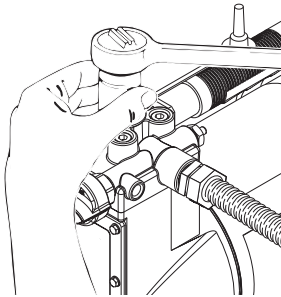

3. Test movement of the valve by pushing on it from the open end of the valve housing with a screwdriver or the eraser end of a pencil. It should move about 1/16 of an inch. If it does not move, it should be cleaned or replaced.

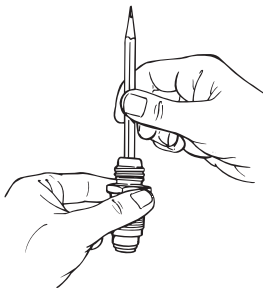

NOTE: The inlet valve must be oiled after every job. This will reduce or eliminate priming problems the next time the sprayer is used.

4. Thoroughly clean the valve assembly with water or the appropriate solvent. Use a small brush.
5. If you have properly cleaned the valve and water drips out of the bottom, the valve is worn and needs to be replaced. A properly seated valve filled with water and held vertically will not drip.
6. Install a new or cleaned valve in the pump block and then fill the valve with light oil or solvent.

Removing and Cleaning the Outlet Valve

It may be necessary to remove and clean the outlet valve or to replace parts inside the valve worn out through normal use.

1. Remove the outlet valve body with a wrench.

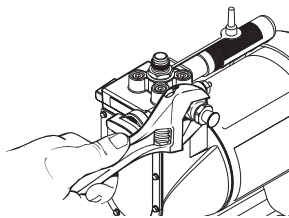

2. Remove and clean the ball stop and small spring inside the valve using a wire hook or tweezers. Replace the spring if it is broken or worn.

NOTE: This spring is manufactured to a very specific tension. Do not put in an unauthorized substitute. See the paint pump assembly parts diagram for the proper replacement part number.

3. Remove the seat and ball assembly.
4. Clean all parts thoroughly. If the ball or seat show any sign of wear or damage, replace them with new parts. This carbide ball must seal tightly against its seat for the valve to function properly.
5. Cover all parts with a thin coat of light oil before reassembling.

NOTE: You will need to align the ridge on the seat with the groove in the pump housing when reassembling.

6. Drop in the valve ball.
7. Insert the ball stop and spring and replace the valve body. Be sure that the o-ring is positioned properly and that the tongue on the cap fits inside the spring.
8. Tighten the valve body securely with an adjustable wrench. Do not over-tighten.

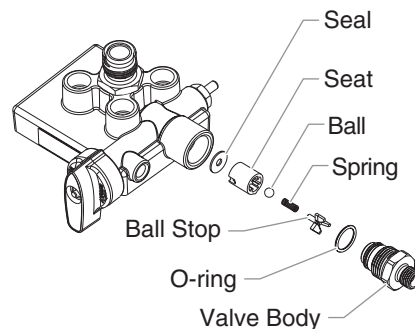

Cleaning the Hopper Screen

The screen at the bottom of the paint hopper may need cleaning periodically. Check it every time you add paint. Remove the screen by pulling it out of the hopper with a pliers. Clean the screen with water or solvent and a soft-bristle brush, if necessary.



Troubleshooting

Problem

The sprayer does not start up.

Cause

1. The sprayer is not plugged in.
2. The ON/OFF switch is set to OFF.
3. Low or no voltage is coming from the wall plug.
4. The sprayer was turned off while still under pressure.
5. The extension cord is damaged or has too low a capacity.
6. The thermal overload on the sprayer is tripped.
7. There is a problem with the motor.

Solution

1. Plug the sprayer in.
2. Turn the ON/OFF switch to ON.
3. Properly test the power supply voltage.
4. Turn the PRIME/SPRAY knob to PRIME.
5. Replace the extension cord.
6. Allow the motor to cool and move the sprayer to a cooler spot.
7. Take the sprayer to a SprayTECH Authorized Service Center.

The sprayer starts up but does not draw in paint when the PRIME/SPRAY knob is set to PRIME.

1. The unit will not prime properly or has lost prime.
2. The paint hopper is empty.
3. The hopper filter is clogged.
4. The inlet valve is stuck.
5. The outlet valve is stuck.
6. The PRIME/SPRAY valve is plugged.
7. The inlet valve is worn or damaged.
8. There is a problem with the diaphragm.
9. The hydraulic oil level is low or empty.

1. Try to prime the unit again.
2. Fill the paint hopper with paint.
3. Clean the hopper filter.
4. Clean the inlet valve.
5. Clean the outlet valve and replace any worn parts.
6. Take the sprayer to a SprayTECH Authorized Service Center.
7. Replace the inlet valve.
8. Take the sprayer to a SprayTECH Authorized Service Center.
9. Take the sprayer to a SprayTECH Authorized Service Center.

The sprayer draws up paint but the pressure drops when the gun is triggered.

1. The spray tip is worn.
2. The hopper filter is clogged.
3. The gun or spray tip filter is plugged.
4. The paint is too heavy or coarse.
5. The outlet valve assembly is dirty or worn.
6. The inlet valve assembly is damaged or worn.

1. Replace the spray tip with a new tip.
2. Clean the hopper filter.
3. Clean or replace the proper filter. Always keep extra filters on hand.
4. Thin or strain the paint.
5. Clean or replace the outlet valve assembly.
6. Replace the inlet valve.

The sprayer will not shut off.

1. The inlet or outlet valve ball or ball seat is worn.
2. Foreign matter or paint has built up between the ball and the seat.

1. Take the sprayer to a SprayTECH Authorized Service Center.
2. Take the sprayer to a SprayTECH Authorized Service Center.

The spray gun leaks.

1. Internal parts of the gun are worn or dirty.

1. Take the sprayer to a SprayTECH Authorized Service Center.

The tip assembly leaks.

1. The tip was assembled incorrectly.
2. A seal is worn.

1. Check the tip assembly and assemble properly.
2. Replace the seal.

The spray gun will not spray.

1. The spray tip, the gun filter or the tip filter is plugged.
2. The spray tip is in the CLEAN position.

1. Clean the spray tip, gun filter or tip filter.
2. Put the tip in the SPRAY position.

The paint pattern is tailing.

1. The pressure is set too low.
2. The gun, the tip, or the hopper filter is plugged.
3. The tip is worn.
4. The paint is too thick.

1. Increase the pressure.
2. Clean the filters.
3. Replace the spray tip.
4. Thin the paint.

The thermal overload tripped and shut off the sprayer.

1. The motor overheated.
2. The extension cord is too long or is too small a gauge.
3. Paint has built up on the motor.
4. The motor was started while the sprayer was under pressure.
5. The sprayer was sitting in the hot sun.

1. Allow to cool for 30 minutes.
2. Allow to cool for 30 minutes and replace the extension cord with a shorter extension or a thicker gauge cord.
3. Clean the paint from the motor.
4. Restart the sprayer in the PRIME mode.
5. Move the sprayer out of the sun.

NOTE: When the PRIME/SPRAY valve is on SPRAY and there is flow through the return tube, remove the PRIME/SPRAY valve and clean or replace it.

NOTE: The electric motor should always be kept clean and dry. Paint acts as an insulator. Too much paint on the motor will cause the motor to overheat.

Consignes de sécurité

⚠ ATTENTION

CET ENSEMBLE EST DOTÉ D'UN DISPOSITIF DE REMISE EN MARCHÉ AUTOMATIQUE AVEC PROTECTION THERMIQUE. EN CAS DE SURCHARGE, CE DISPOSITIF DÉBRANCHE LE MOTEUR DU BLOC D'ALIMENTATION.

- Le moteur se remet en marche sans avertissement lorsque le protecteur est réarmé automatiquement.
- Il faut toujours débrancher le moteur du bloc d'alimentation avant de travailler sur le matériel.
- Lorsque le dispositif de remise en marche automatique débranche le moteur du bloc d'alimentation, réduire la pression en tournant la soupape d'amorçage à AMORCER.
- Mettre l'interrupteur MARCHÉ/ARRÊT à ARRÊT.

NOTA : Il faut remédier à la cause de la surcharge avant de relancer l'appareil. À ce sujet, voir la rubrique DÉPANNAGE.

⚠ AVERTISSEMENT

DANGER: Blessures résultant d'une injection cutanée - Le jet de peinture haute pression produit par cet appareil peut transpercer la peau et les tissus sous-jacents, causant des blessures graves pouvant aller jusqu'à l'amputation.

NE PAS TRAITER CE TYPE DE BLESSURE COMME S'IL S'AGISSAIT D'UNE SIMPLE COUPURE ! Une amputation peut en résulter. Consulter un médecin immédiatement. Le plus haut niveau de fonctionnement du pistolet est une pression du fluide de 2800 PSI.

PRÉVENTION:

- NE JAMAIS diriger le pulvérisateur vers toute partie du corps.
- NE JAMAIS placer toute partie du corps devant le jet. ÉVITER d'entrer en contact avec un jet de fluide sortant d'une fuite dans le tuyau à fluide.
- NE JAMAIS placer les mains devant le pulvérisateur. Les gants ne sont pas une protection suffisante contre les risques d'injection cutanée.
- TOUJOURS bloquer la détente du pistolet, fermer la pompe à fluide et décharger toute la pression avant de faire de l'entretien, de nettoyer le protecteur de la tête, de changer de tête ou de laisser l'appareil sans surveillance. Le bouton AMORCER/PULVÉRISER doit être tourné à AMORCER, afin d'éliminer la pression. Consulter la PROCÉDURE DE LIMITATION DE LA PRESSION décrite dans le présent manuel.
- Toujours débrancher le pistolet avant d'effectuer toute opération d'entretien ou de nettoyage du protecteur de tête ou de remplacement des embouts, ou lorsque le pistolet n'est pas utilisé.
- TOUJOURS garder le protecteur de tête en place durant l'opération de pulvérisation. Ce dispositif fournit une certaine protection contre toute blessure résultant d'une injection cutanée; on l'utilise principalement à titre d'avertissement.
- TOUJOURS enlever la tête de pulvérisation avant d'effectuer un lavage ou un nettoyage du système.
- Des fuites peuvent être provoquées dans le tuyau à peinture par l'usure, par des faux plis ou par la mauvaise utilisation. Une fuite peut injecter des substances dans la peau, et il est donc indispensable d'examiner le tuyau à peinture avant chaque utilisation.
- NE JAMAIS utiliser un pistolet qui ne soit pas muni d'un cran de sûreté ou de pontet en place et en bon état de fonctionnement.
- Tous les accessoires doivent avoir une valeur nominale d'au moins 2800 PSI. Cette exigence s'applique aux têtes de pulvérisation, aux pistolets, aux rallonges et aux tuyaux.

REMARQUE DESTINÉE AU MÉDECIN:

Une injection cutanée est une blessure du type traumatique. Il est essentiel de traiter ce genre de blessure à l'aide d'une intervention chirurgicale et ce, dans les plus brefs délais. NE PAS retarder le traitement dans le but d'effectuer des recherches sur le degré de toxicité du produit. La toxicité d'un produit ne doit être considérée que pour certaines substances ayant été directement injectées dans les vaisseaux sanguins. Il pourrait s'avérer nécessaire de consulter un spécialiste en chirurgie plastique, ou encore, un spécialiste en chirurgie reconstructive de la main.

DANGER: EXPLOSION OU INCENDIE - Les émanations provenant des solvants et des peintures peuvent exploser ou s'enflammer, entraînant des dommages matériels ou des blessures graves.

PRÉVENTION:

- Un approvisionnement d'air frais et une évacuation des gaz doivent être assurés, afin que l'air entourant la zone de pulvérisation soit libre de toute accumulation de vapeurs inflammables.
- Éviter toute source d'ignition, telle que des étincelles d'électricité statique, des flammes nues, des veilleuses, des objets chauds, des cigarettes, ou des étincelles produites lors du branchement ou du débranchement des cordons d'alimentation ou du déclenchement des interrupteurs d'éclairage.
- Des appareils d'extinction d'incendie doivent être en place et en bon état de fonctionnement.
- Garder la pompe à l'écart de la zone de pulvérisation, afin d'éviter les vapeurs de solvants et de peintures.
- L'écoulement à haute vitesse d'un liquide à travers le matériel peut générer l'électricité statique. Il faut donc assurer une bonne mise à la terre du matériel dont on se sert ainsi que des objets dans la zone de pulvérisation et aux alentours, pour éviter la décharge de l'électricité statique et les étincelles.
- Pour le travail sans air, utiliser uniquement les tuyaux à fluide à haute pression qui soient mis à la terre ou qui soient bons conducteurs de l'électricité. S'assurer que le pistolet est mis à la terre correctement à travers les raccords des tuyaux.
- Respecter les mesures de sécurité et les avertissements du fabricant des solutions et des produits.
- Lors du lavage du matériel, utiliser la plus basse pression possible.

⚠ AVERTISSEMENT

DANGER: EXPLOSION CAUSÉE PAR L'INCOMPATIBILITÉ DES MATÉRIAUX - Peut causer des dommages matériels ou des blessures graves.

PRÉVENTION:

- Ne pas utiliser de l'eau de Javel.
- Ne pas utiliser de solutions halocarbonées, tels que le chlorure de méthylène et le 1-1-1 trichloro-éthane. Ces produits ne sont pas compatibles avec l'aluminium et peuvent provoquer une explosion. En cas de doute, communiquer avec le fournisseur du produit en question.

DANGER: VAPEURS DANGEREUSES - Les peintures, les solutions, les insecticides et autres produits peuvent être dangereux en cas d'inhalation, provoquant des nausées graves, des évanouissements ou un empoisonnement.

PRÉVENTION:

- Utiliser un respirateur ou un masque dans toute situation où il y a risque d'inhalation de vapeurs. Lire toute la documentation accompagnant le produit de pulvérisation et le masque, afin de s'assurer qu'une protection adéquate est offerte contre l'inhalation de vapeurs dangereuses.
- Utiliser des lunettes de protection pour empêcher les vapeurs dangereuses de pénétrer dans les yeux.

DANGER : GÉNÉRALITÉS - Peut causer des dommages matériels ou des blessures graves

PRÉVENTION:

- Lire toutes les directives et toutes les mesures de sécurité portant sur l'équipement et sur le produit de pulvérisation avant l'emploi de tout équipement.
- Se conformer aux règlements locaux, provinciaux et nationaux appropriés régissant la ventilation, la prévention des incendies et l'exécution des opérations.
- Les normes de sécurité du gouvernement des États-Unis ont été adoptées en application de la Occupational Safety and Health Act (OSHA) (Loi sur la santé et la sécurité au travail). Il convient de prendre connaissance de ces normes, et surtout de l'article 1910 des Normes générales et de l'article 1926 des Normes de construction.
- Cette pompe, qui fonctionne à haute pression sans air, est conçue pour être utilisée exclusivement avec des pièces autorisées par le fabricant. L'utilisateur qui emploie cette pompe avec des pièces qui ne se conforment pas à la spécification minimum et aux mesures de sûreté prévues par le fabricant de la pompe assume tous les risques et toutes les responsabilités découlant d'un tel usage.
- Avant chaque utilisation, vérifier tous les tuyaux pour repérer éventuellement des coupures, des fuites, des zones d'abrasion et le renflement du revêtement ainsi que des dommages aux raccords ou leur déplacement. Si un de ces problèmes est constaté, il faut remplacer le tuyau immédiatement. Ne jamais réparer un tuyau à peinture; il faut le remplacer avec un autre tuyau mis à la terre.
- Tous les tuyaux, pivots, pistolets et accessoires utilisés avec ce matériel doivent avoir une valeur nominale d'au moins 2800 PSI.
- Ne pas pulvériser par des temps de grand vent.



Utiliser uniquement une rallonge à trois fils dotée d'une fiche de mise à la terre à trois broches et d'une prise à trois fentes pouvant accepter la fiche sur le produit. S'assurer que la rallonge est en bon état. S'assurer également que cette dernière convient au courant consommé par l'appareil. Pour une longueur inférieure à 15,2 m (50 pieds), utiliser une rallonge no 18 AWG. Pour une longueur supérieure à 15,2 m (50 pieds), utiliser une rallonge no 14 ou no 16 AWG. Une rallonge de section inférieure produira une perte de tension, entraînant une perte de puissance et la surchauffe. On recommande l'utilisation d'un cordon de calibre 14 ou 12.

NOTA : Ne pas utiliser plus de 100 pieds de cordon de rallonge. Au cas où il serait nécessaire de faire de la peinture à une distance de plus de 100 pieds du bloc d'alimentation, utiliser d'autres tuyaux à peinture et non pas d'autres rallonges. Par ailleurs, les rallonges plus courtes assureront une alimentation maximale et un bon fonctionnement.

Instructions de mise à la terre

Cet appareil doit être mis à la terre. La mise à la terre réduit les risques d'électrocution lors d'un court-circuit en permettant au courant de s'écouler par le fil de mise à la terre. Cet appareil est muni d'un cordon électrique avec fil de mise à la terre ainsi que d'une fiche de terre. La fiche doit être branchée sur une prise installée correctement et mise à la terre conformément à la réglementation et aux codes en vigueur.

DANGER — Une prise de terre mal branchée peut être à l'origine d'électrocutions. S'il s'avère nécessaire de réparer ou de remplacer le cordon électrique ou la fiche, ne pas brancher le fil vert de mise à la terre sur l'une ou l'autre des bornes à broche plate. Le fil recouvert d'un isolant vert avec ou sans rayures jaunes est le fil de mise à la terre et doit être branché sur la broche de mise à la terre.

Si vous ne comprenez pas les instructions de mise à la terre ou si vous n'êtes pas sûr que l'appareil est correctement mis à la terre, contactez un électricien agréé. Ne pas modifier la fiche d'origine. Si la prise ne convient pas à la fiche, faites installer la prise adéquate par un électricien agréé.

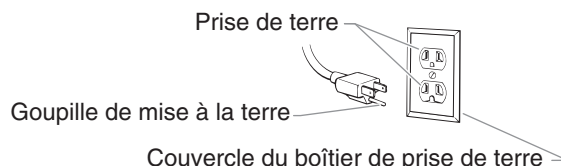

Utiliser uniquement une rallonge à trois fils munie d'une fiche de terre dans une prise secteur mise à la terre correspondant au type de fiche de l'appareil. S'assurer que votre rallonge est en bon état. Lorsque vous utilisez une rallonge, assurez-vous qu'elle soit d'un calibre suffisant pour supporter l'intensité du courant requise par l'appareil. Une rallonge trop mince entraîne une chute de tension, une diminution de l'intensité et une surchauffe. Une rallonge de calibre 12 est recommandée. Si vous devez utiliser une rallonge à l'extérieur, celle-ci doit comprendre la marque W-A après la désignation indiquant le type de cordon. Par exemple, la désignation SJTW-A indique que le cordon est conçu pour être utilisé à l'extérieur.

Advertencias de seguridad

⚠ PRECAUCION

LA UNIDAD CUENTA CON UN MECANISMO DE RESTABLECIMIENTO AUTOMÁTICO TÉRMICAMENTE PROTEGIDO. EL MECANISMO DE RESTABLECIMIENTO AUTOMÁTICO TÉRMICAMENTE PROTEGIDO HACE QUE EL MOTOR SE DESCONECTE DEL SUMINISTRO DE ENERGÍA SI SE PRESENTA UNA SOBRECARGA.

- El motor arrancará de nuevo sin ninguna advertencia cuando el protector se restablezca automáticamente.
- Desconecte siempre el motor del suministro de energía antes de empezar a trabajar con el equipo.
- Cuando el mecanismo de restablecimiento automático térmicamente protegido haga que el motor se desconecte del suministro de energía, gire la válvula de cebadura hasta la posición PRIME (cebar) para liberar la presión.
- Gire el interruptor ON/OFF (encendido/apagado) hasta la posición OFF (apagado).

NOTA: La causa de la sobrecarga debe corregirse antes de arrancar de nuevo. Vea la sección DETECCIÓN DE PROBLEMAS.

⚠ ADVERTENCIA

PELIGRO: LESIÓN DE PERFORACIÓN – Este equipo produce un chorro de pintura a alta presión que puede perforar la piel y los tejidos que se encuentran abajo, ocasionando lesiones graves y la posible amputación.

¡NO SE TRATE COMO UNA SIMPLE CORTADURA! la perforación de la piel puede llevar a la amputación. Véase inmediatamente a un médico.

El valor máximo de operación de la pistola corresponde a una presión de fluido de 2800 lb/pulg2.

PREVENCIÓN:

- JAMAS apunte la pistola hacia cualquier parte de su cuerpo.
- JAMAS permita que alguna parte de su cuerpo entre en contacto con el chorro. EVITE TENER CONTACTO con el fluido que salga de fugas que haya en la manguera de fluido.
- JAMAS ponga su mano delante de la pistola. Los guantes no proporcionan protección adecuada contra lesiones de perforación.
- Bloquee SIEMPRE el gatillo de la pistola, apague la bomba de fluido y libere toda la presión antes de dar mantenimiento, limpiar el protector de la boquilla, cambiar las boquillas o dejar desatendido el sistema. La presión no se liberará al apagar el motor. Para liberar la presión debe girarse la perilla PRIME/SPRAY hasta la posición PRIME. Consulte el PROCEDIMIENTO DE LIBERACIÓN DE PRESIÓN que se describe en este manual.
- SIEMPRE desenchufe la pistola de pulverización antes de dar servicio, limpiar el protector de la punta, cambiar las boquillas o dejar la pistola sin supervisión.
- Quite SIEMPRE la boquilla del atomizador antes de enjuagar o limpiar el sistema.
- Pueden desarrollarse fugas en la manguera de pintura por causa del desgaste, retorcimientos o el abuso. Una fuga es capaz de inyectar el material en la piel. Inspeccione antes la manguera de pintura cada vez que la use.
- No use NUNCA una pistola de atomización que no tenga un bloqueador o un protector de gatillo puesto y que funcione.

- Todos los accesorios deben tener una capacidad de 2800 lb/pulg2 o mayor. Esto incluye las boquillas de atomización, las pistolas, las extensiones y la manguera.

NOTA PARA EL MÉDICO:

El a perforación de la piel constituye un serio traumatismo. Es importante tratar quirúrgicamente la herida lo más pronto posible. NO RETRASE el tratamiento para poder estudiar la toxicidad. La toxicidad es importante cuando determinadas resinas exóticas penetran directamente en el torrente sanguíneo. Se recomienda consultar con un cirujano plástico o un cirujano especializado en la reconstrucción de las manos.

PELIGRO: EXPLOSION O FUEGO - Los vapores emitidos por solventes y pinturas pueden explotar o incendiarse, causando daños a la propiedad y/o severas lesiones personales.

PREVENCIÓN:

- Suministre aire fresco y de escape para evitar la acumulación de vapores inflamables en el ambiente que rodea al pulverizador.
- Evite cualquier fuente de encendido como las chispas de electricidad estática, llamas, luces piloto, objetos calientes, cigarrillos y chispas producidas por la conexión o desconexión de cables de alimentación eléctrica o conmutadores de luces.
- Mantenga equipo de extinción cerca y en buenas condiciones.
- Mantenga la bomba lejos del área de atomización para evitar los vapores de solvente y pintura.
- Un flujo de material con una velocidad elevada que atraviese el equipo puede generar electricidad estática. El equipo que se utilice, así como los objetos que estén dentro y alrededor del área de atomización, deben conectarse a tierra de manera apropiada para prevenir las descargas eléctricas y las chispas.
- Use solamente mangueras para fluidos de alta presión conductoras o conectadas a tierra para las aplicaciones sin aire. Asegúrese de que la pistola esté conectada a tierra de manera apropiada mediante conexiones de manguera.
- Observe las precauciones y advertencias de seguridad del fabricante con respecto al uso de sustancias y solventes.
- Cuando enjuague el equipo utilice la presión más baja posible.

⚠ ADVERTENCIA

PELIGRO: EXPLOSIONES OCASIONADAS POR SUBSTANCIAS INCOMPATIBLES - Pueden causar daños a la propiedad o lesiones graves.

PREVENCIÓN:

- No use blanqueadores.
- No use solventes que contengan hidrocarburos halogenados, como el cloruro de metileno y el 1,1,1-tricloroetano. Estas sustancias no son compatibles con el aluminio y podrían ocasionar una explosión. Si tiene dudas acerca de la compatibilidad de una sustancia con el aluminio, póngase en contacto con su proveedor de recubrimientos.

PELIGRO: VAPORES PELIGROSOS - Las pinturas, los solventes, los insecticidas y otras sustancias pueden ser dañinos al inhalarse y causar severas náuseas, desmayos o envenenamiento.

PREVENCIÓN:

- Use un respirador o una mascarilla cuando exista la posibilidad de inhalación de vapores. Léanse todas las instrucciones incluidas con las sustancias que se vayan a rociar y con la mascarilla para asegurar la protección necesaria contra la inhalación de vapores dañinos.

PELIGRO: GENERAL - Puede causar daños a la propiedad o severas lesiones.

PREVENCIÓN:

- Antes de operar cualquier equipo, lea todas las instrucciones y los avisos de seguridad del equipo y de las sustancias que se vayan a rociar.
- Observe todas las normas locales, estatales y nacionales relativas a la ventilación, prevención y operación.
- Los Estándares de Seguridad del Gobierno de los Estados Unidos se han adoptado bajo el Acta de Seguridad y Salud Ocupacionales (OSHA por sus siglas en inglés). Deben consultarse estos estándares, particularmente la parte 1910 de los Estándares Generales y la parte 1926 de los Estándares de la Construcción.
- La bomba de alta presión sin aire está diseñada para usarse solamente con piezas autorizadas por el fabricante. Cuando se use esta bomba con piezas que no cumplan con las especificaciones mínimas ni con los dispositivos de seguridad del fabricante de la bomba, el usuario asumirá todos los riesgos y responsabilidades legales.
- Antes de usarlo cada vez, revise todas las mangueras para ver que no tengan cortadas, fugas, una cubierta desgastada por abrasión o con abolladuras, así como uniones dañadas o que se hayan movido. Si existiera cualquiera de estas condiciones, reemplace la manguera inmediatamente. No repare nunca una manguera de pintura. Reemplácela con otra manguera conectada a tierra.
- Todas las mangueras, soportes giratorios, pistolas y accesorios que se usen con esta unidad deben tener una capacidad de presión de 2800 lb/pulg2 o mayor.
- No atome en días con viento.

PRECAUCION

Use sólo un cable de extensión de tres hilos que tenga un enchufe con tres contactos y un tomacorriente con conexión de tierra que sea compatible con el enchufe del producto. Asegúrese que su cable de extensión esté en buenas condiciones. Cuando use un cable de extensión, asegúrese de usar uno que pueda soportar la corriente que consuma su producto. Para distancias inferiores a 50 pies, use un cable de extensión AWG No. 18. Para distancias mayores de 50 pies use un cable de extensión AWG No. 14 ó 16. Un cable de menor capacidad causará una caída del voltaje de la línea, ocasionando pérdida de potencia y recalentamiento. Se recomienda un alambre de calibre 14 ó 12.

NOTA: No use una extensión de más de 100 pies. Si necesita pintar a una distancia que esté más allá de 100 pies de su fuente de energía, alargue la manguera de pintura, no la extensión. Las extensiones más cortas asegurarán que se tenga la máxima energía eléctrica para una operación apropiada.

Instrucciones para conectar a tierra

Este producto se debe conectar a tierra. En caso de que ocurra un corto circuito, la conexión a tierra reduce el riesgo de choque eléctrico al proporcionar un alambre de escape para la corriente eléctrica. Este producto está equipado con un cable que tiene un alambre de conexión a tierra con un enchufe de conexión a tierra apropiado. El enchufe se debe enchufar en una toma de corriente que se haya instalado y conectado a tierra debidamente, de acuerdo con todos los códigos y estatutos locales.

PELIGRO — Una instalación inapropiada del enchufe de conexión a tierra puede dar como resultado el que exista un riesgo de choque eléctrico. Si es necesario reparar o reemplazar el cable o el enchufe, no conecte el alambre de conexión a tierra a ninguno de los terminales de hoja planos. El alambre con aislamiento que tiene la superficie exterior de color verde con franjas amarillas o sin ellas es el alambre de conexión a tierra que debe conectarse al conector de conexión a tierra.

Verifique con un electricista o técnico de servicio calificado si las instrucciones para conectar a tierra no le han quedado completamente claras, o si duda que el producto haya quedado conectado a tierra de manera apropiada. No modifique el enchufe que se proporciona. Si el enchufe no entra en la toma de corriente, pídale a un electricista calificado que instale la toma apropiada.

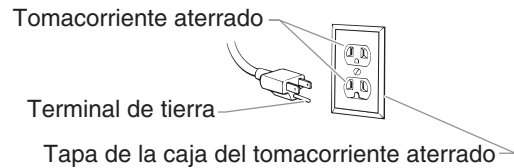

PRECAUCION

Use solamente extensiones trifilares que tengan un enchufe de conexión a tierra de 3 hojas y un receptáculo de triple ranura que acepte el enchufe del producto. Asegúrese de que su extensión esté en buenas condiciones. Cuando use una extensión, asegúrese de usar una que sea lo suficientemente resistente como para soportar la corriente que descargue su producto. Un cable de un tamaño menor causará una caída de voltage en la línea que dará como resultado una pérdida de energía y un sobrecalentamiento. Se recomienda usar un cable de calibre 12. Si se utiliza un cable de extensión en el exterior, tiene que estar marcado con el sufijo W-A después de la designación del tipo de cable. Por ejemplo, SJTW-A para indicar que el cable es apropiado para uso en exteriores.

Parts Listing

Main Assembly

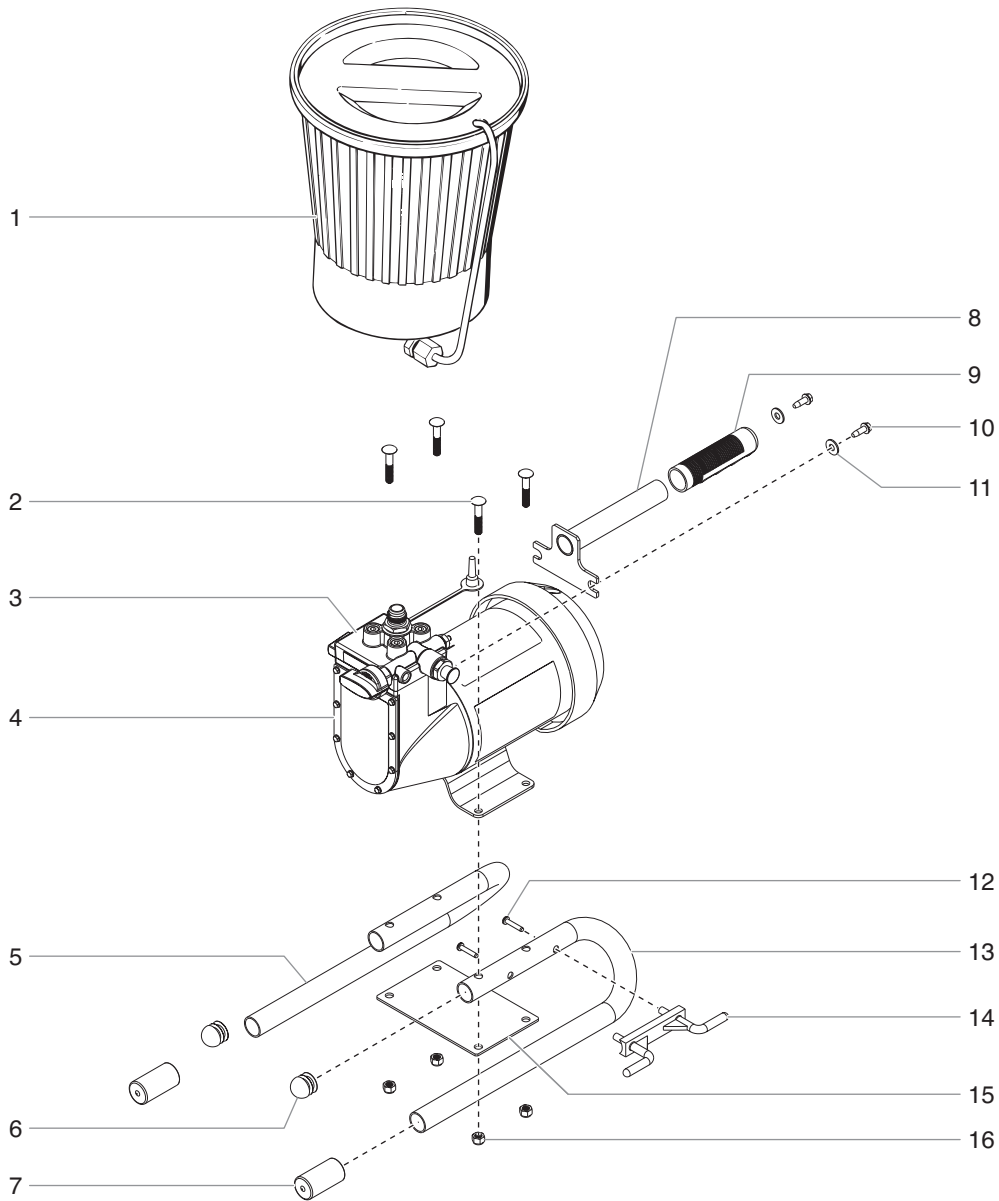

<u>Item</u>	<u>Part #</u>	<u>Description</u>	<u>Quantity</u>	<u>Item</u>	<u>Part #</u>	<u>Description</u>	<u>Quantity</u>
1	0288144	Hopper assembly.....	1	9	0288478	Handle grip	1
2	9801533	Carriage bolt	4	10	0508276	Screw	2
3	-----	Pump head assembly	1	11	9820206	Washer.....	2
4	0555124	Diaphragm pump	1	12	0508660	Screw.....	2
5	0508271	Left leg	1	13	0508270	Right leg.....	1
6	0551525	Plug.....	2	14	0508377	Cord wrap	1
7	0555513	Tube cap.....	2	15	0508267	Mounting plate	1
8	0508259	Handle assembly	1	16	9811122	Lock nut	4

Diaphragm Pump (P/N 0555124)

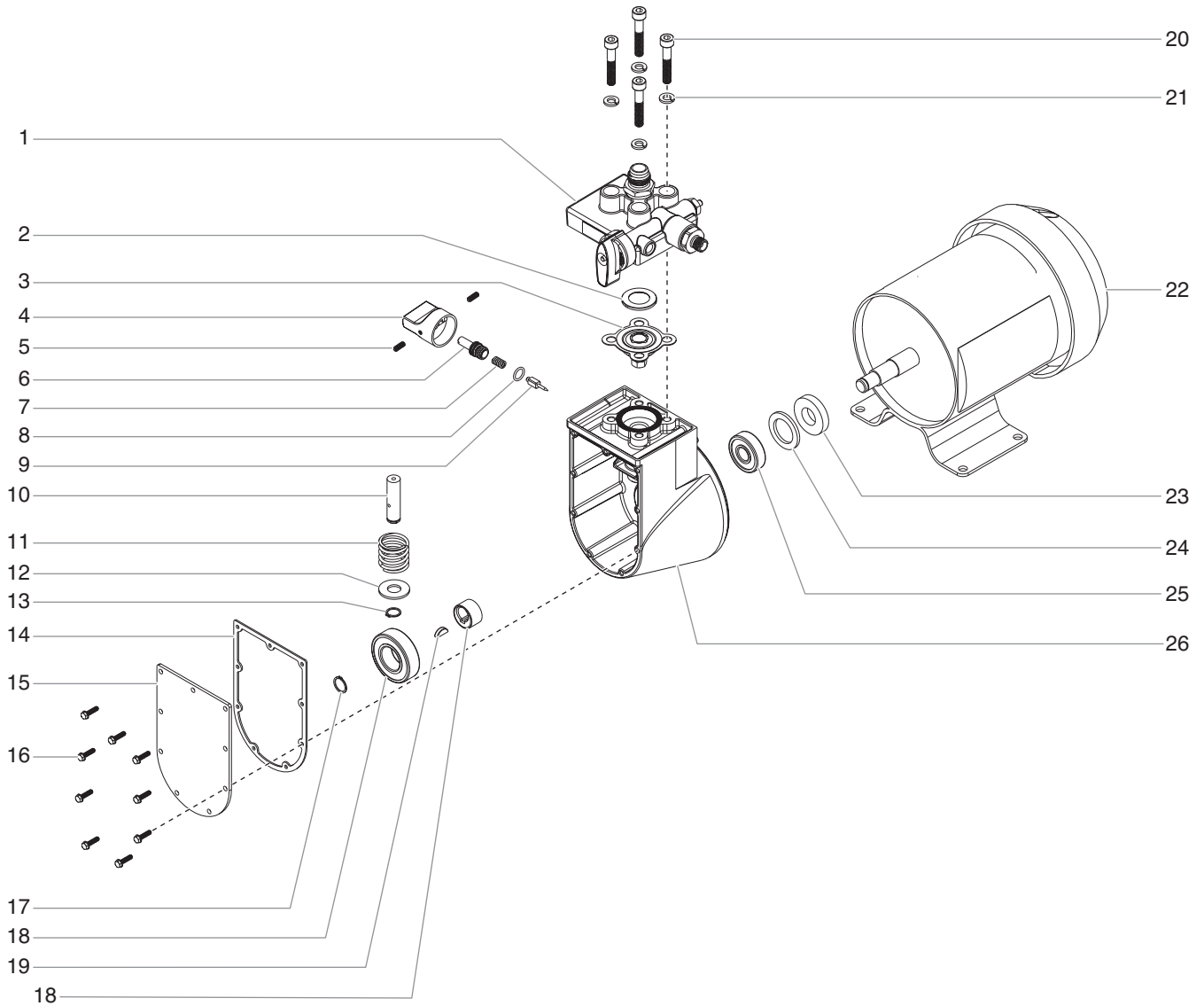

Item	Part #	Description	Quantity	Item	Part #	Description	Quantity
1	0555123	Pump head	1	16	9800049	Screw.....	9
2	0270494	Diaphragm ring	1	17	0047393	Retaining ring.....	1
3	0278240	Diaphragm	1	18	0090031	Eccentric sleeve and bearing assembly	1
4	0288775	Pressure control knob.....	1	19	0089829	Shaft key.....	1
5	9801109	Set screw	2	20	9900355	Socket screw	4
6	0270529	Valve stem	1	21	9921601	Lock washer.....	4
7	0047373	Pressure regulating spring.....	1	22	0270546	Motor (includes items 27 and 28).....	1
8	0089518	O-ring	1	23	0089930	Seal.....	1
9	0089475	Pressure valve needle	1	24	0270477	Seal.....	1
10	0278339	Hydraulic piston	1	25	0089929	Ball bearing.....	1
11	0005311	Piston spring.....	1	26	0278237	Hydraulic housing assembly (includes items 23 – 25).....	1
12	0270548	Piston washer	1	27	0270462	Fan (not shown).....	1
13	0089456	Retainer	1	28	0270612	Fan cover (not shown).....	1
14	0278359	Gasket	1				
15	0278341	Hydraulic cover.....	1				

Pump Head Assembly

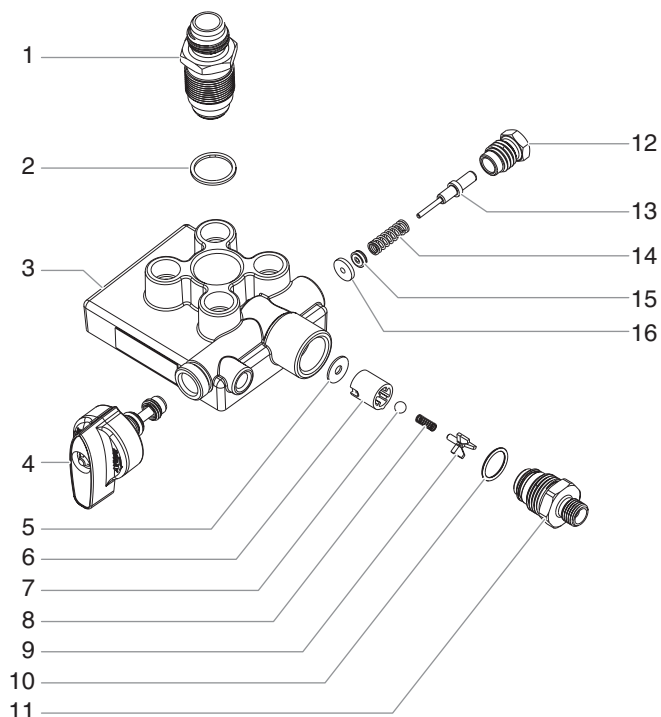

Item	Part #	Description	Quantity
1	0278242	Inlet valve assembly (includes item 2).....	1
2	0089482	Sealing washer, nylon.....	1
3	0278334	Paint pump.....	1
4	0555850	PRIME/SPRAY valve assembly.....	1
5	0278362	Outlet seal.....	1
6	0278241	Ball seat.....	1
7	0093635	Ball.....	1
8	0047485	Outlet spring.....	1
9	0278361	Ball guide.....	1
10	9871114	O-ring.....	1
11	0278335	Outlet fitting.....	1
12	0278337	Pusher body.....	1
13	0278250	Pusher stem assembly.....	1
14	0278368	Pusher spring.....	1
15	0156646	Seal.....	1
16	0278340	Pusher washer.....	1

Hopper Assembly

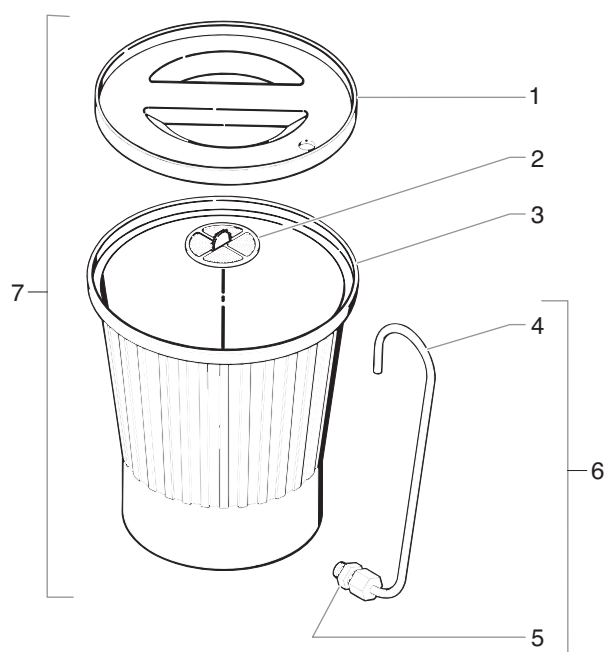

Item	Part #	Description	Quantity
1	0279591	Cover, hopper.....	1
2	0089917	Filter screen, fine (shown).....	1
3	0088871	Filter screen, coarse.....	1
4	0093865	Return tube.....	1
5	0090617	Fitting.....	1
6	0090560	Return tube assembly.....	1
7	0279971	Hopper complete.....	1

Notes/Nota

Limited Warranty

SprayTECH, a division of Wagner Spray Tech Corporation ("SprayTECH"), warrants that at the time of delivery to the original purchaser for use ("End User"), the equipment covered by this warranty is free from defects in material and workmanship. With the exception of any special, limited, or extended warranty published by SprayTECH, SprayTECH's obligation under this warranty is limited to replacing or repairing without charge those parts which, to SprayTECH's reasonable satisfaction, are shown to be defective within twelve (12) months after sale to the End User. This warranty applies only when the unit is installed and operated in accordance with the recommendations and instructions of SprayTECH.

This warranty does not apply in the case of damage or wear caused by abrasion, corrosion or misuse, negligence, accident, faulty installation, substitution of non- SprayTECH component parts, or tampering with the unit in a manner to impair normal operation.

Defective parts are to be returned to an authorized SprayTECH sales/service outlet. All transportation charges, including return to the factory, if necessary, are to be borne and prepaid by the End User. Repaired or replaced equipment will be returned to the End User transportation prepaid.

THERE IS NO OTHER EXPRESS WARRANTY. SPRAYTECH HEREBY DISCLAIMS ANY AND ALL IMPLIED WARRANTIES INCLUDING, BUT NOT LIMITED TO, THOSE OF MERCHANTABILITY AND FITNESS FOR A PARTICULAR PURPOSE, TO THE EXTENT PERMITTED BY LAW. THE DURATION OF ANY IMPLIED WARRANTIES WHICH CANNOT BE DISCLAIMED IS LIMITED TO THE TIME PERIOD SPECIFIED IN THE EXPRESS WARRANTY. IN NO CASE SHALL SPRAYTECH LIABILITY EXCEED THE AMOUNT OF THE PURCHASE PRICE. LIABILITY FOR CONSEQUENTIAL, INCIDENTAL OR SPECIAL DAMAGES UNDER ANY AND ALL WARRANTIES IS EXCLUDED TO THE EXTENT PERMITTED BY LAW.

SPRAYTECH MAKES NO WARRANTY AND DISCLAIMS ALL IMPLIED WARRANTIES OF MERCHANTABILITY AND FITNESS FOR A PARTICULAR PURPOSE WITH RESPECT TO ACCESSORIES, EQUIPMENT, MATERIALS OR COMPONENTS SOLD BUT NOT MANUFACTURED BY SPRAYTECH. THOSE ITEMS SOLD, BUT NOT MANUFACTURED BY SPRAYTECH (SUCH AS GAS ENGINES, SWITCHES, HOSES, ETC.) ARE SUBJECT TO THE WARRANTY, IF ANY, OF THEIR MANUFACTURER. SPRAYTECH WILL PROVIDE THE PURCHASER WITH REASONABLE ASSISTANCE IN MAKING ANY CLAIM FOR BREACH OF THESE WARRANTIES.

Patents

These products are covered by one or more of the following U.S. patents:

5,286,045	D349,711	5,263,789	5,252,210	D345,841	5,059,099	5,084,964
5,217,238	4,720,801	4,785,719	4,828,464	5,145,331	4,390,324	4,403,924
4,928,722	4,416,588	4,003,504	RE29,055	4,624,602	4,834,287	5,073,092
D376,637	D387,414	D382,938	3,963,180	4,025,045	D405,159	D412,965
5,505,381	5,765,753	5,887,793	5,893,522			

Material Safety Data Sheets (MSDS) are available on SprayTECH's website or by calling Technical Service.



Technical Assistance: 1-800-292-4637
Order Entry: 1-800-443-4500
Fax: 1-800-525-9501

www.spraytechinc.com

Free Manuals Download Website

<http://myh66.com>

<http://usermanuals.us>

<http://www.somanuals.com>

<http://www.4manuals.cc>

<http://www.manual-lib.com>

<http://www.404manual.com>

<http://www.luxmanual.com>

<http://aubethermostatmanual.com>

Golf course search by state

<http://golfingnear.com>

Email search by domain

<http://emailbydomain.com>

Auto manuals search

<http://auto.somanuals.com>

TV manuals search

<http://tv.somanuals.com>