

D **GB** **F** **I**

WAGNER®

Betriebsanleitung

Operating manual p. 30

Mode d'emploi p. 60

Istruzioni per l'uso..... p. 90

Airless Hochdruck-Spritzgerät

Airless high-pressure spraying unit

Groupe de projection à haute pression

Impianto per la verniciatura a spruzzo ad alta pressione Airless

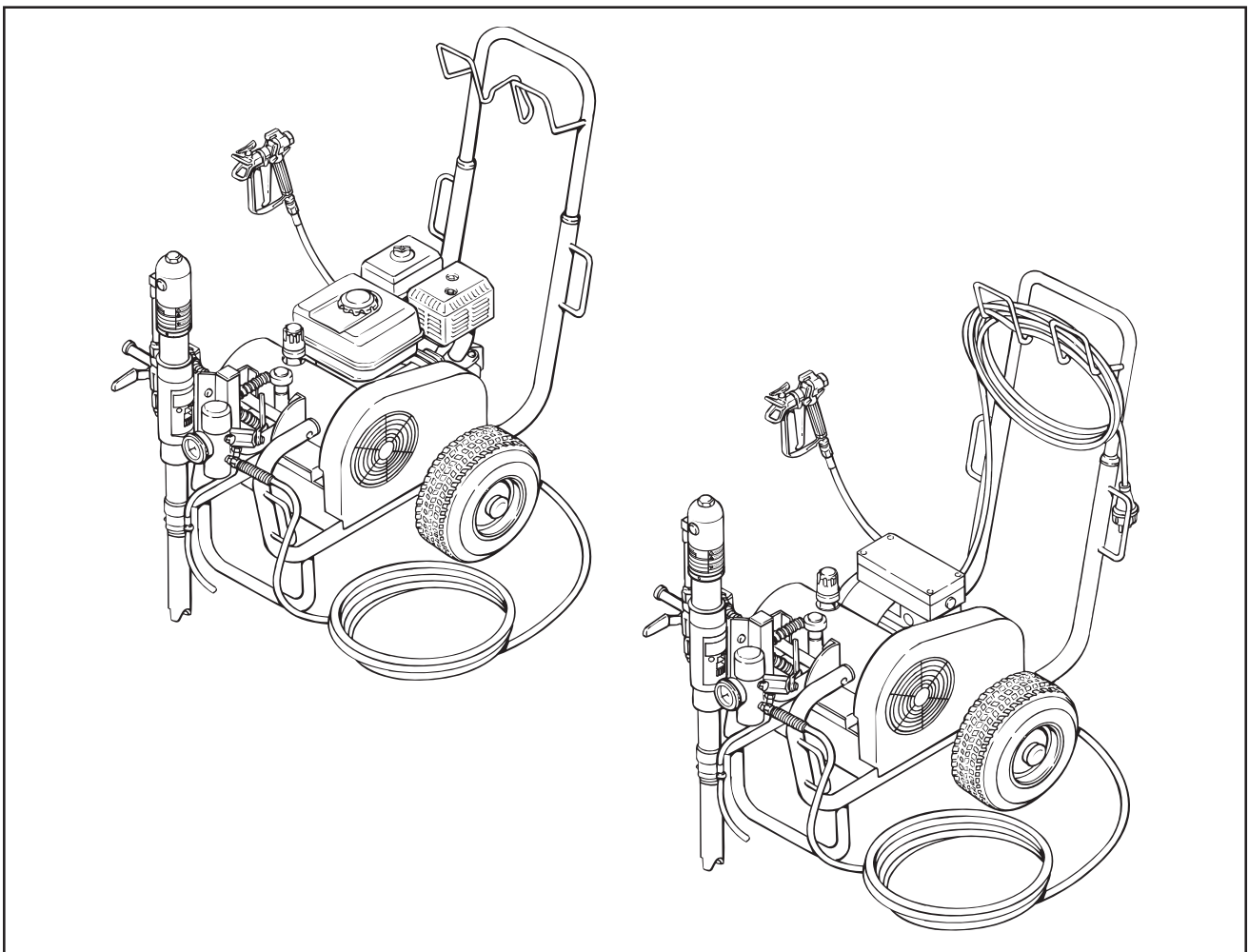

HC 920 • HC 940 • HC 960
HC 940-SSP • HC 960-SSP

Warning!

Attention: Danger of injury by injection!
Airless units develop extremely high spraying pressures.

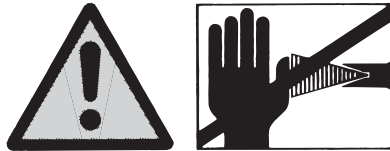

Danger

Never put your fingers, hands, or any other parts of the body into the spray jet!
 Never point the spray gun at yourself, other persons, or animals!
 Never use the spray gun without tip safety guard!

1

Do not treat an injection injury as a harmless cut. In case of injury to the skin through coating materials or solvents, consult a doctor immediately for quick and expert treatment. Inform the doctor about the coating material or solvent used.

The operating instructions state that the following points must always be observed before starting up:

2

1. Faulty units must not be used.
2. Secure WAGNER spray gun using the safety catch on the trigger.
3. Ensure that the unit is properly earthed.
4. Check allowable operating pressure of high-pressure hose and spray gun.
5. Check all connections for leaks.

The instructions regarding regular cleaning and maintenance of the unit must be strictly observed.

3

Before any work is done on the unit or for every break in work the following rules must be observed:

1. Release the pressure from spray gun and hose.
2. Secure the WAGNER spray gun using the safety catch on the trigger.
3. Switch off the gasoline engine.

Be safety-conscious!

Contents

	Page		Page
1. Safety regulations for Airless spraying	32	11. Standard equipment of HC units	49
2. General view of application	33	12. Accessories and spare parts	49
2.1 Application	33	12.1 Accessories for HC units	49
2.2 Coating materials	34	Accessories illustration for HC units	120
3. Description of unit	34	12.2 Spare parts list for the material feed pump	
3.1 Airless process	34	HC 920	50
3.2 Functioning of the unit	34	Spare parts diagram for the material	
3.3 Illustration legend for gasoline HC units	35	feed pump HC 920	121
3.4 Illustration of gasoline HC units	35	12.3 Spare parts list for the material feed pump	
3.5 Illustration legend for electric HC units	36	HC 940 • HC 940-SSP • HC 960 •	
3.6 Illustration of electric HC units	36	HC 960-SSP	51
3.7 Technical data for gasoline HC units	37	Spare parts diagram for the material feed	
3.8 Technical data for electric HC units	38	pump HC 940 • HC 940-SSP • HC 960 •	
3.9 Transport	39	HC 960-SSP	121
3.10 Transport in vehicle	39	12.4 Spare parts list for the shovel valve	
3.11 Crane transport	39	HC 940-SSP • HC 960-SSP	51
4. Starting operation	40	Spare parts diagram for the shovel valve	
4.1 Swivel mechanism of the material		HC 940-SSP • HC 960-SSP	122
feed pump	40	12.5 Spare parts list for the high-pressure filter	
4.2 Changing the material feed pump position	40	Spare parts diagram for the high-pressure	
4.3 High-pressure hose,		filter	123
spray gun and separating oil	41	12.6 Spare parts list for the hydraulic system	53
4.4 Gasoline engine (gas units only)	42	Spare parts diagram for the hydraulic	
4.5 Connection to the mains (electric units only)	42	system	124/125
4.6 Cleaning preserving agent when starting-up		12.7 Spare parts list for units	
of operation initially	42	with a gasoline engine	54
4.7 Taking the unit into operation		Spare parts diagram for units	
with coating material	42	with a gasoline engine	126
5. Spraying technique	43	12.8 Spare parts list for units	
6. Handling the high-pressure hose	43	with an electric motor	54
6.1 High pressure hose	43	Spare parts diagram for units	
7. Interruption of work	43	with an electric motor	127
8. Cleaning the unit (shutting down)	43	12.9 Spare parts list for the carriage	55
8.1 Cleaning the unit from the outside	44	Spare parts diagram for the carriage	128
8.2 Suction filter HC 920	44	12.10 Electrical schematic HC920 • HC940	56
8.3 Cleaning the high-pressure filter	44	12.11 Electrical schematic HC960	56
8.4 Cleaning Airless spray gun	45	13. Appendix	57
9. Remedy in case of faults	46	13.1 Selection of tip	57
9.1 Gasoline engine	46	13.2 Servicing and cleaning of Airless	
9.2 Electric motor	46	hard-metal tips	57
9.3 Hydraulic motor	46	13.3 Spray gun accessories	57
9.4 Material feed pump	47	13.4 Airless tip table	58
10. Servicing	48	Sales and service companies	59
10.1 General servicing	48	Important notes on product liability	130
10.2 Checking the oil level in the hydraulic		3+2 years guarantee for professional finishing	130
oil tank	48	CE Declaration of conformity	134
10.3 Oil and oil filter change of the hydraulic			
oil pump	48		
10.4 High-pressure hose	48		

1. Safety regulations for Airless spraying

All local regulations in force must be observed.
For secure handling of Airless high-pressure spraying units the following safety regulations are to be observed:

● Flash point



Only use coating materials with a flash point of 21°C or above without additional heating.
The flash point is the lowest temperature at which vapours develop from the coating material.

These vapours are sufficient to form an inflammable mixture over the air above the coating material.

● Explosion protection



Do not use the unit in work places which are covered by the explosion protection regulations.

● Danger of explosion and fire from sources of ignition during spraying work



There must be no sources of ignition such as, for example, open fires, lit cigarettes, cigars or tobacco pipes, sparks, glowing wires, hot surfaces, etc. in the vicinity.

● Danger of injury from the spray jet

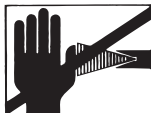

Caution! Danger of injury by injection!

Never point the spray gun at yourself, other persons or animals.

Never use the spray gun without spray jet safety guard.

The spray jet must not come into contact with any part of the body.

In working with Airless spray guns, the high spray pressures arising can cause very dangerous injuries. If contact is made with the spray jet, coating material can be injected into the skin. Do not treat a spray injury as a harmless cut. In case of injury to the skin by coating material or solvents, consult a doctor for quick and correct treatment.

Inform the doctor about the coating material or solvent used.

● Secure the spray gun against unintentional operation

Always secure the spray gun when mounting or dismounting the tip and in case of interruption to work.

● Recoil of spray gun



When using a high operating pressure, pulling the trigger guard can effect a recoil force up to 15 N.
If you are not prepared for this, your hand can be thrust backwards or your balance lost. This can lead to injury.

● Respiratory protection for protection against vapours of solvents

Wear respiratory protection when spraying.
The user must be provided with a breathing mask.

● Prevention of occupational illnesses

Protective clothing, gloves and possibly skin protection cream are necessary for the protection of the skin.

Observe the regulations of the manufacturer concerning coating materials, solvents and cleaning agents in preparation, processing and cleaning units.

● Max. operating pressure

The permissible operating pressure for the spray gun, spray gun accessories, and high-pressure hose must not fall short of the maximum operating pressure of 22.8 MPa (228 bar).

● High-pressure hose (safety note)

Electrostatic charging of spray guns and the high-pressure hose is discharged through the high-pressure hose. For this reason the electric resistance between the connections of the high-pressure hose must be equal to or lower than 1MΩ.



For reasons of function, safety and durability use only original Wagner high-pressure hoses.

● Electrostatic charging (formation of sparks or flame)



Under certain circumstances, electrostatic charging can occur on the unit due to the rate of flow of the coating material when spraying. On discharging this can result in the emergence of sparks or fire. It is therefore necessary that the unit is always earthed through the electrical installation. The unit must therefore always be earthed via the carriage frame.

● Installing the unit (gasoline units)



Use the Airless spraying unit with a gasoline engine, preferably outdoors.

Take the wind direction into account. Then place the unit so that no vapors containing solvents are deposited in the area of the unit.

Observe a minimum distance of 3 m between the unit with gasoline engine and the spray gun.

Observe a minimum distance of 3 m between the unit with gasoline engine and the spray gun.

● Using unit on construction sites (electric units)

Connection to the mains only through a special feed point, e.g. through an error protection installation with INF < 30 mA

● Ventilation when spraying in rooms

Adequate ventilation must be guaranteed in order to remove the solvent vapors and the exhaust fumes of the gasoline engine.

● Suctions installations

These are to be set-up by the user of the unit according to local regulations.

● Earthing of the object

The object to be coated must be earthed.

● Cleaning the unit with solvents



When cleaning the unit with solvents, the solvent should never be sprayed or pumped back into a container with a small opening (bunghole). An explosive gas/air mixture can arise. The container must be earthed.

● Cleaning the unit



Danger of short-circuits caused by water ingressing into the electrical equipment of the gasoline engine.

Never spray down the unit with high-pressure or high-pressure steam cleaners.

● Work or repairs on the electrical equipment

Only have this work carried out by a qualified electrician. No liability will be taken for incorrect installation.

● Working on electrical components

Remove the power cord from the socket during all repair work.

● Setting-up on uneven surfaces

The front side of the unit must point downwards to prevent sliding away.

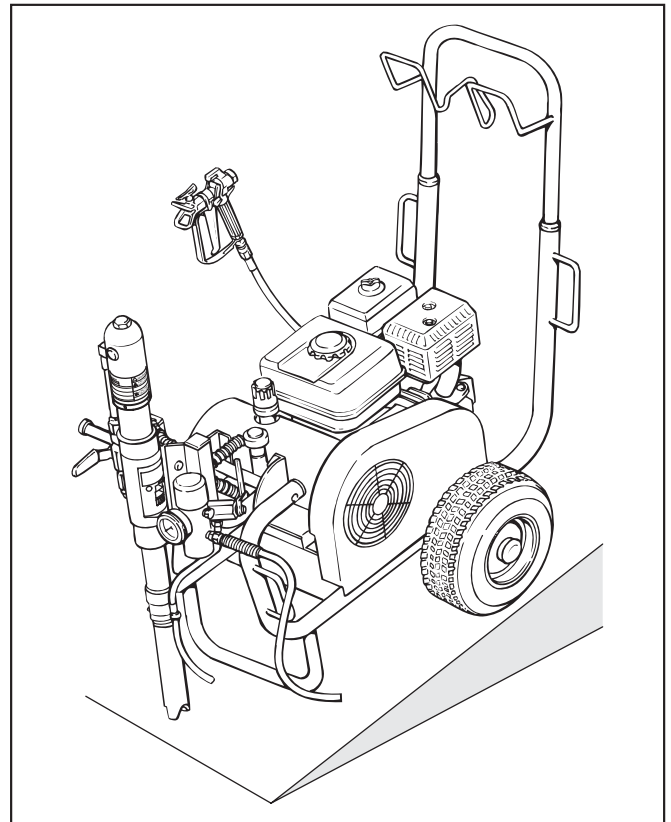

2. General view of application

2.1 Application

Priming and final coating of large areas, sealing, impregnation, construction sanitation, façade protection and renovation, rust protection and building protection, roof coating, roof sealing, concrete sanitation, as well as heavy corrosion protection.

Examples of objects to be sprayed

Large-scale construction sites, underground construction, cooling towers, bridges, sewage treatment plants and terraces.

Generally for the whole building protection where operation without electric power is required.

2.2 Coating materials

Processible coating materials



Pay attention to the Airless quality of the coating materials to be processed.

Dilutable lacquers and paints or those containing solvents, primer and filler, synthetic-resin paints, acrylics, epoxies, latex paints, reactant paints, dispersion paints, fire protection and thick film materials, zinc dust and micaceous iron ore paints, Airless spray primer, sprayable glue and bitumen-like coating materials.

No other materials should be used for spraying without WAGNER's approval.

HC 940-SSP

With suitable accessories, especially for working with airless spray primer.

HC 960-SSP

Especially suited to working with airless spray primer directly from the container (see accessories).

Filtering

In spite of the high-pressure filter, filtering of the coating material is to be recommended in general.

Stir coating material before commencement of work.



Make sure when stirring with motor-driven agitators that no air bubbles are stirred in. Air bubbles disturb when spraying and can, in fact, lead to interruption of operation.

Viscosity

It is possible to work with high-viscosity coating materials with the devices.

If highly viscous coating materials cannot be sucked up, they must be diluted in accordance with the manufacturer's instruction.

Two-component coating material

The appropriate processing time must be adhered to exactly. Within this time rinse through and clean the unit meticulously with the appropriate cleaning agents.

Coating materials with sharp-edged additional materials

These have a strong wear and tear effect on valves, high-pressure hose, spray gun and tip. The durability of these parts can be reduced appreciably through this.

3. Description of unit

3.1 Airless process

The main area of application are thick layers of highly viscous coating material for large areas and a high consumption of material.

A piston pump takes in the coating material by suction and conveys it to the tip. Pressed through the tip at a pressure of up to a maximum of 228 bar (22.8 MPa), the coating material is atomised. This high pressure has the effect of micro fine atomisation of the coating material.

As no air is used in this process, it is described as an AIRLESS process.

This method of spraying has the advantages of finest atomisation, cloudless operation and a smooth, bubble-free surface. As well as these, the advantages of the speed of work and convenience must be mentioned.

3.2 Functioning of the unit

The following section contains a brief description of the technical construction for better understanding of the function.

WAGNER HC 920 • 940 • 960 are high-pressure spraying units driven by either a gasoline engine or electric motor.

The gasoline engine or electric motor (fig. 2, item 1) drives the hydraulic pump (3) by means of a V-belt which is under the belt cover (2). Hydraulic oil flows to the hydraulic motor (4) and then moves the piston up and down in the material feed pump (5).

With devices HC 940-SSP and HC 960-SSP, the piston in the material feed pump moves a shovel valve (6). The shovel valve feeds high-viscosity coating materials.

The inlet valve is opened automatically by the upwards movement of the piston. The outlet valve is opened when the piston moves downward.

The coating material flows under high pressure through the high-pressure hose to the spray gun. When the coating material exits from the tip it atomises.

The pressure control valve (7) controls the volume and the operating pressure of the coating material.

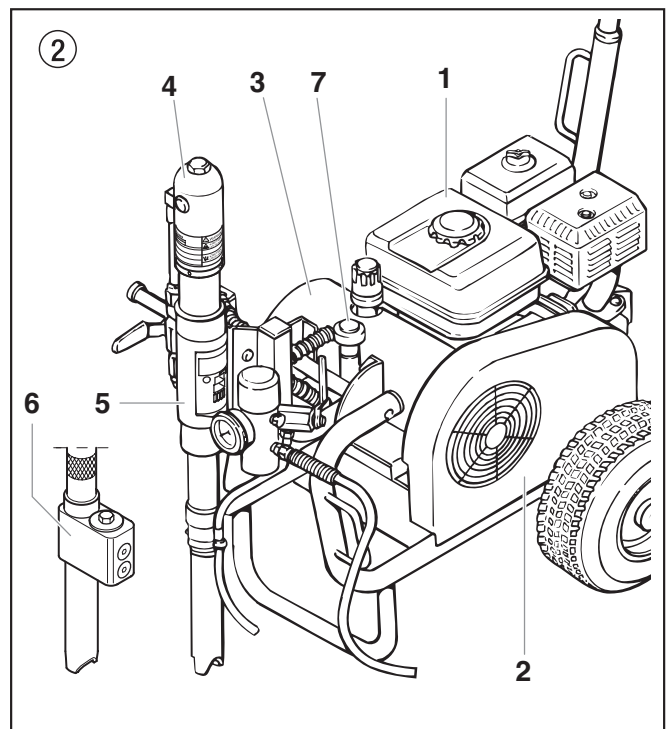

3.3 Illustration legend for gasoline HC units

- | | |
|--|---|
| 1 Spray gun | 13 Oil cup for separating oil (separating oil prevents increased wear and tear of the packings) |
| 2 High-pressure hose | 14 Ball valve horizontal position – hydraulic motor switched off |
| 3 Gasoline engine | vertical position – hydraulic motor switched on |
| 4 Extractable handle | 15 Handle for swiveling the material feed pump |
| 5 V-belt under the belt cover | 16 Hydraulic motor |
| 6 Return hose | 17 Relief valve handle |
| 7 Suction tube | Turn left for circulation ↺ |
| 8 High-pressure filter | Turn right for spray ↻ |
| 9 Material feed pump – HC 940, HC 960 | 18 Hydraulic oil pump |
| 10 Material feed pump – HC 940-SSP, HC 960-SSP | 19 Pressure control knob |
| 11 Material feed pump – HC 920 | 20 Oil measuring stick |
| 12 Pressure gauge | |

3.4 Illustration of gasoline HC units

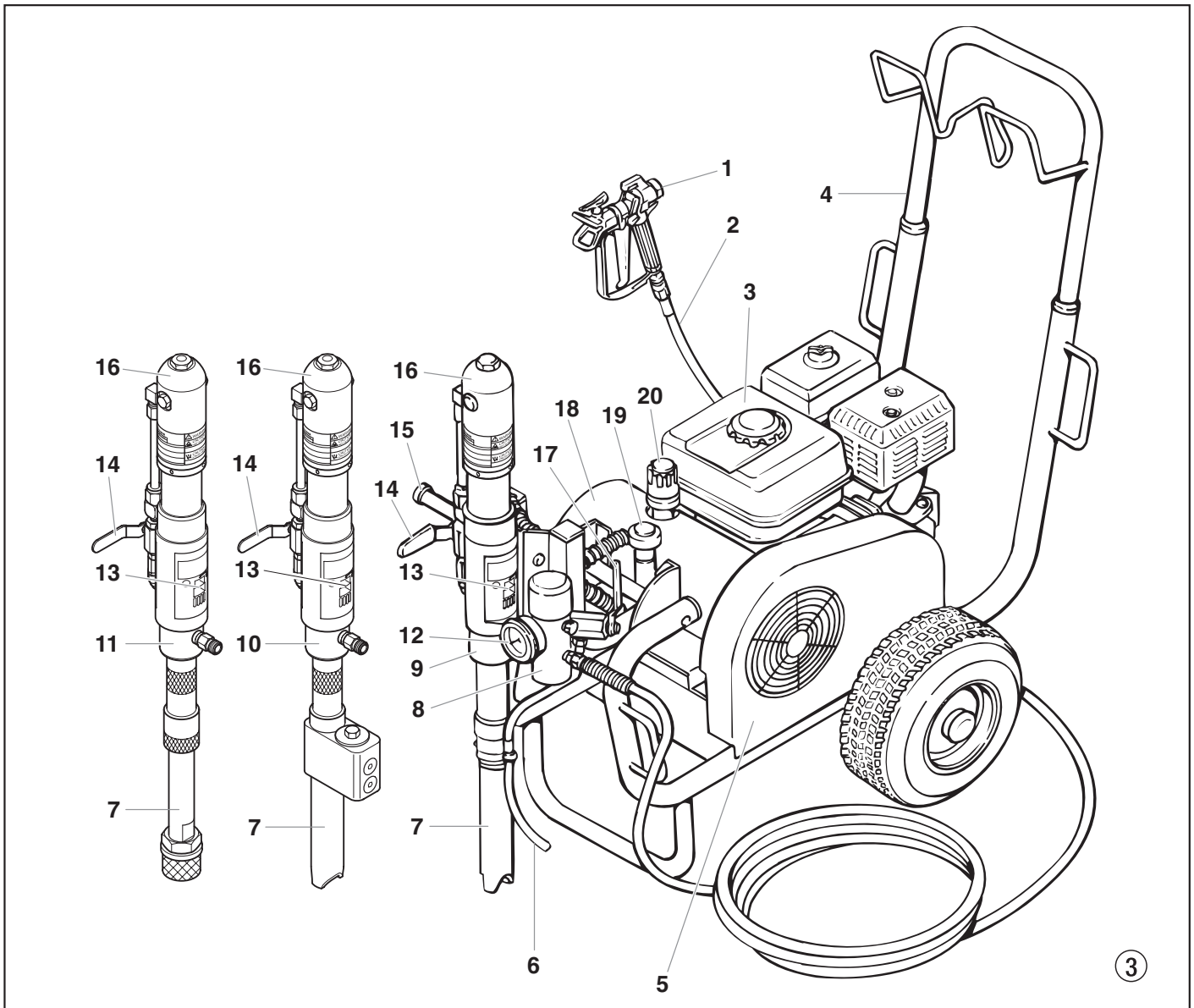

3.5 Illustration legend for electric HC units

- | | |
|---|---|
| 1 Spray gun | 16 Material feed pump — HC 920 |
| 2 High-pressure hose | 17 Pressure gauge |
| 3 Electric motor | 18 Oil cup for separating oil (separating oil prevents increased wear and tear of the packings) |
| 4 ON/OFF switch — HC 920, HC 940, HC 940-SSP | 19 Ball valve horizontal position — hydraulic motor switched off |
| 5 Control lamp that shows unit operational — HC 920, HC 940, HC 940-SSP | vertical position — hydraulic motor switched on |
| 6 Power cord | 20 Handle for swiveling the material feed pump |
| 7 Extractable handle | 21 Hydraulic motor |
| 8 Control lamp that shows unit operational — HC 960, HC 960-SSP | 22 Relief valve handle |
| 9 ON/OFF switch (400 V) — HC 960, HC 960-SSP | Turn left for circulation ↻ |
| 10 V-belt under the belt cover | Turn right for spray ➤ |
| 11 Return hose | 23 Hydraulic oil pump |
| 12 Suction tube | 24 Pressure control knob |
| 13 High-pressure filter | 25 Oil measuring stick |
| 14 Material feed pump — HC 940, HC 960 | |
| 15 Material feed pump — HC 940-SSP, HC 960-SSP | |

3.6 Illustration of electric HC units

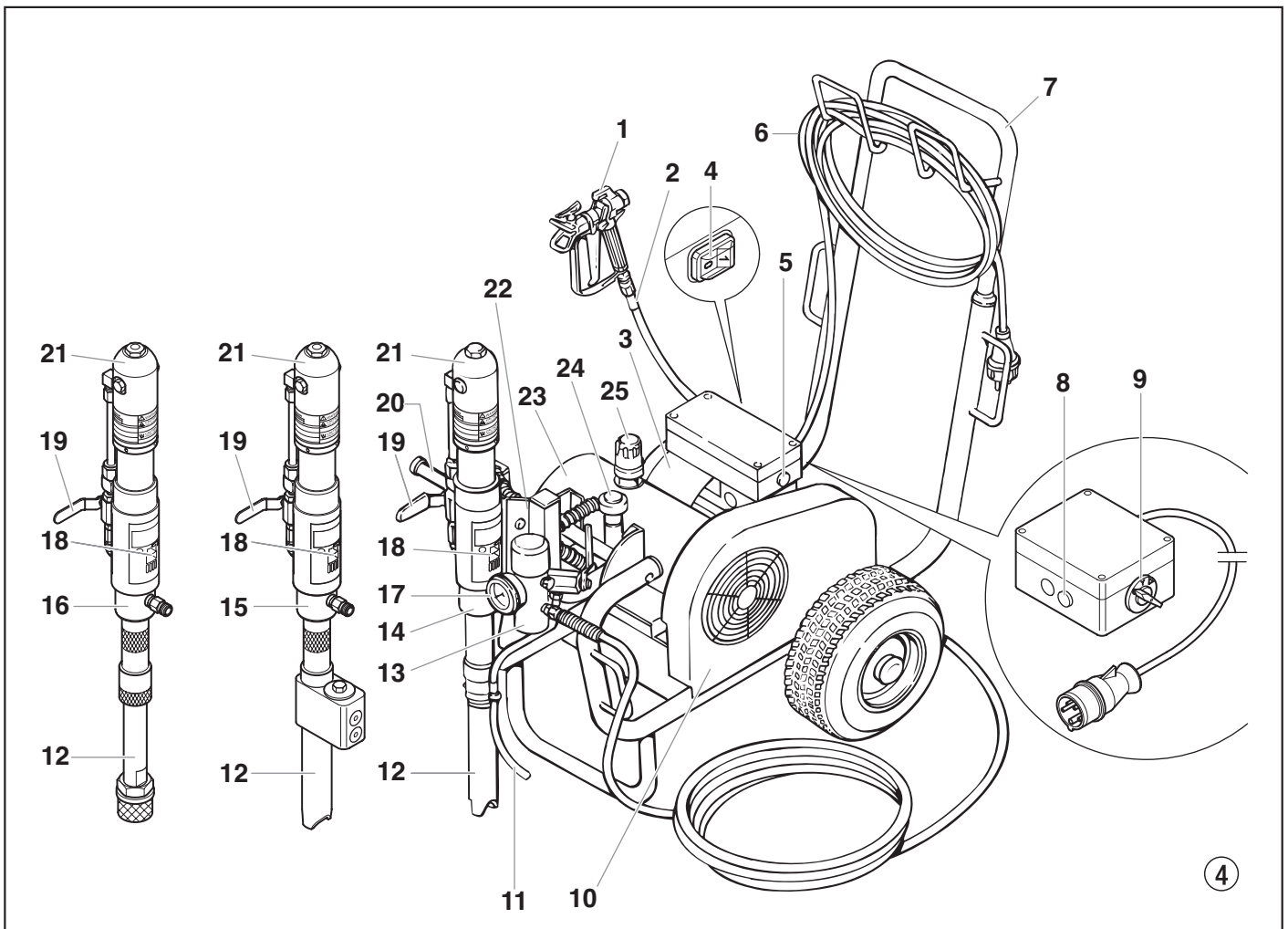

3.7 Technical data for gasoline HC units

	HC 920	HC 940	HC 940-SSP	HC 960	HC 960-SSP
Gasoline engine, power					
3 kW:	*				
4.1 kW:		*	*		
6 kW:				*	*
Max. operating pressure					
22.8 MPa (228 bar):	*	*	*	*	*
Max. volume flow					
5.5 l/min:	*				
8 l/min:		*	*		
12 l/min:				*	*
Volume flow at 12 MPa (120) bar					
5 l/min:	*				
7.6 l/min:		*	*		
11 l/min:				*	*
Max. size of tip with a spray gun					
0.043 inch – 1.10 mm:	*				
0.052 inch – 1.30 mm:		*	*		
0.056 inch – 1.42 mm:				*	*
Max. temperature of the coating material					
43° C:	*	*	*	*	*
Max. Viscosity					
40.000 mPa·s:	*				
50.000 mPa·s:		*	*		
65.000 mPa·s:				*	*
Filter insert (standard equipment)					
5 Maschen:	*				
0 Maschen:		*	*	*	*
Weight					
74 kg	*				
76 kg		*	*		
88 kg				*	*
Hydraulic oil filling quantity					
4.7 l ESSO Nuto H 32:	*	*	*	*	*
max. Reifendruck					
0.2 MPa (2 bar):	*	*	*	*	*
Special high-pressure hose					
DN 10 mm, 15 m, connection thread NPSM 3/8:	*	*			
DN 13 mm, 15 m, connection thread NPSM 1/2:			*	*	*
DN 19 mm, 15 m, connection thread NPSM 3/4:			*	*	*
Hose whip					
DN 10 mm, 2.5 m, connection thread NPSM 3/8:			*	*	*
Dimensions L x W x H					
1160 x 955 x 655 mm:	*				
1185 x 955 x 655 mm:		*	*		
1200 x 955 x 655 mm:				*	*
Max.sound pressure level:					
90 dB (A)*	*				
92 dB (A)*		*	*		
98 dB (A)*				*	*

* Place of measurement: 1 m distance from unit and 1.60 m above reverberant floor, 120 bar (12 MPa) operating pressure.

3.8 Technical data for electric HC units

	HC 920	HC 940	HC 940-SSP	HC 960	HC 960-SSP
Voltage					
230 V~, 50 Hz:	*	*	*		
400 V, 50 Hz, V3~:				*	*
Fuse protection					
16 A:		*	*	*	*
Power cord					
3 x 2.5 mm ² – 6 m:	*	*	*		
5 x 2.5 mm ² – 6 m:				*	*
Capacity					
3.1 kW:	*	*	*		
5.5 kW:				*	*
Max operating pressure					
22.8 MPa (228 bar):	*	*	*	*	*
Maximum volume flow					
5.5 l/min:	*				
6.6 l/min:		*	*		
10 l/min:				*	*
Volume flow at 12 MPa (120 bar)					
4.8 l/min:	*				
5.2 l/min:		*	*		
10 l/min:				*	*
Max. size of tip with a spray gun					
0.043 inch – 1.10 mm:	*				
0.052 inch – 1.30 mm:		*	*		
0.056 inch – 1.42 mm:				*	*
Max. temperature of the coating material					
43° C:	*	*	*	*	*
Max. Viscosity					
40.000 mPa·s:	*				
50.000 mPa·s:		*		*	
65.000 mPa·s:			*		*
Filter insert (standard equipment)					
5 Maschen:	*				
0 Maschen:		*	*	*	*
Weight:					
83 kg	*	*			
84.5 kg			*		
100 kg				*	
103 kg					*
Hydraulic oil filling quantity					
4.7 l ESSO Nuto H 32:	*	*	*	*	*
Max. tire pressure					
0.2 MPa (2 bar):	*	*	*	*	*
Special high-pressure hose					
DN 10 mm, 15 m, connection thread NPSM 3/8:	*	*			
DN 13 mm, 15 m, connection thread NPSM 1/2:			*	*	*
DN 19 mm, 15 m, connection thread NPSM 3/4:			*	*	*
Hose whip					
DN 10 mm, 2,5 m, connection thread NPSM 3/8:			*	*	*
Dimensions L x W x H					
1160 x 955 x 655 mm:	*				
1185 x 955 x 655 mm:		*	*		
1200 x 955 x 655 mm:				*	*
Max. sound pressure level:					
77 dB (A)*	*				
80 dB (A)*		*	*		
88 dB (A)*				*	*

* Place of measurement: 1 m distance from unit and 1.60 m above reverberant floor, 12 MPa (120 bar) operating pressure.

3.9 Transport

Handle

Pull out the handle (fig. 5, item 1) until it will come no further. Push in the snap buttons (2) on the sides of the handle and insert the handle.

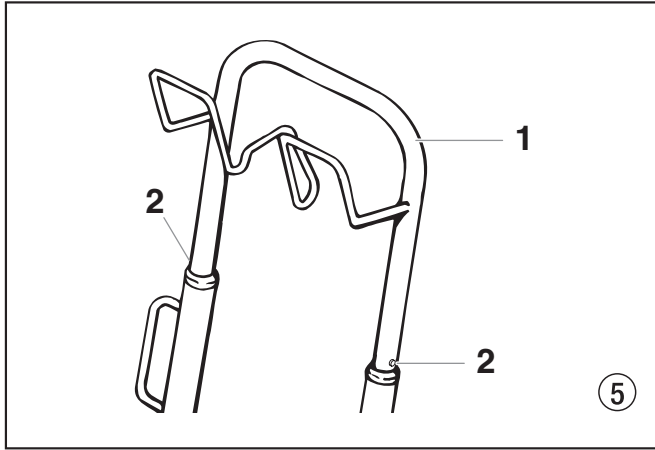

3.10 Transport in vehicle

Push locking pin (fig. 6, item 1) in the swivel mechanism (2) for the material feed pump (3) and swivel it to a horizontal position. Ensure that the locking pin locks.

Roll the high-pressure hose over the hose rack on the handle. Secure the unit with a suitable fastening.

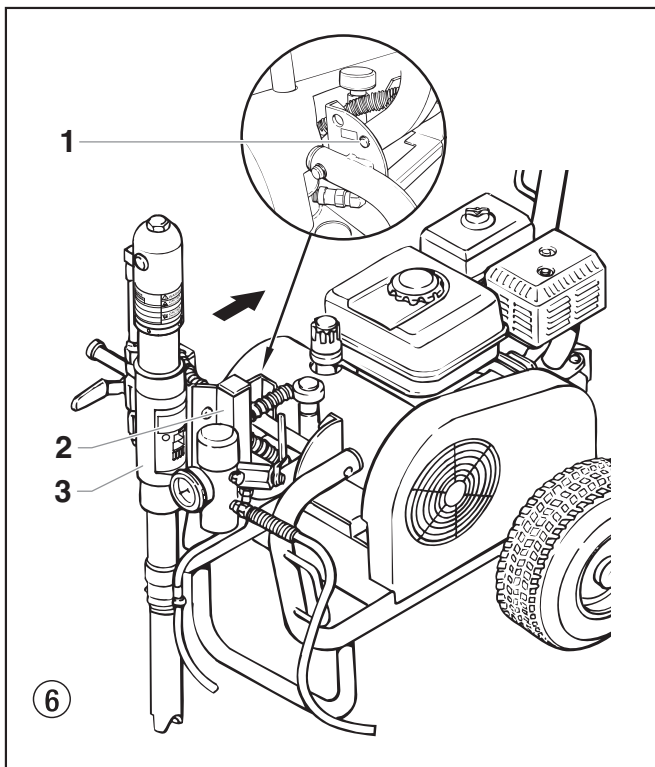

3.11 Crane transport

Hanging points for crane straps or ropes, see figure 7.

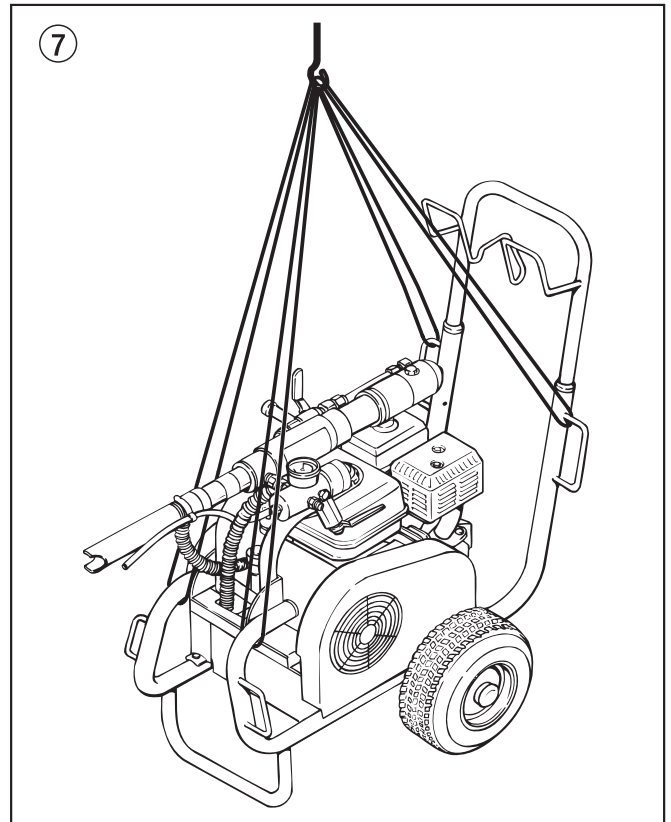

4. Starting operation

4.1 Swivel mechanism of the material feed pump



Be careful, as the moving parts of the swivel mechanism can crush fingers and feet.

1. Transport position (fig. 8)

Transport unit only when the material feed pump is in the horizontal position.

Swiveling the material feed pump to a horizontal position also allows removal of the pump from the coating material container. Ensure that the locking pin locks.

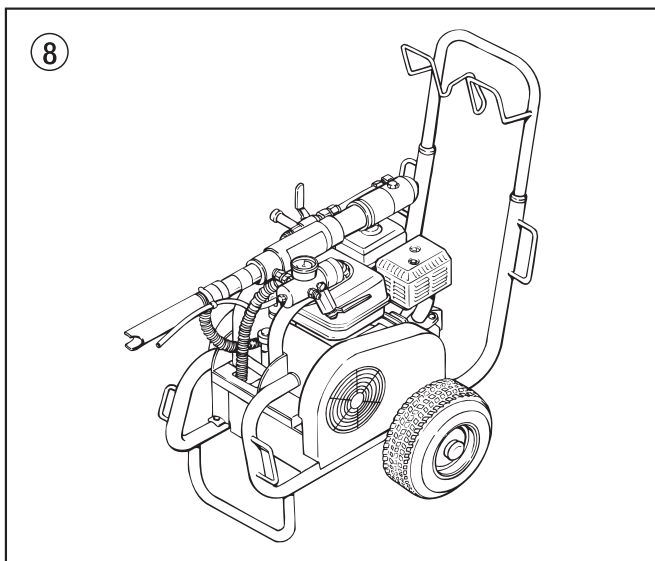

2.0 Operating position I (fig. 9)

Swiveling the material feed pump to a vertical position allows the material feed pump to be immersed in the coating material container.

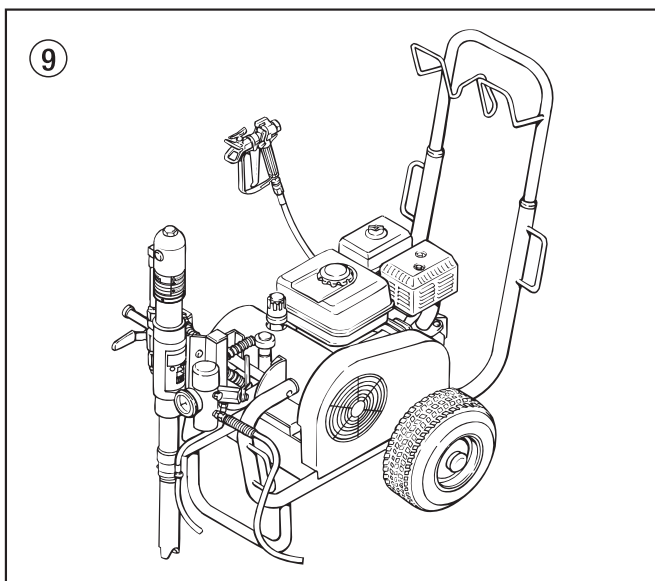

2.1 Operating position II (fig. 10)

Swivel material feed pump to a slanted (45°) position if using the container suction system (accessory). In this position, there is open space under the material feed pump.

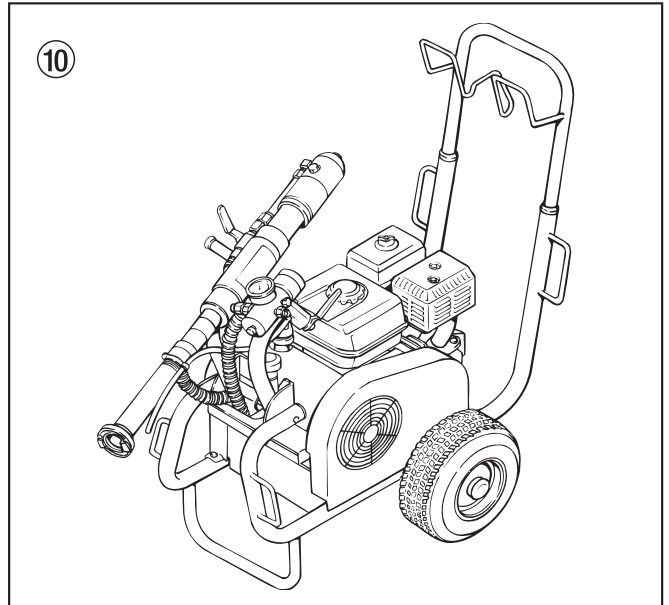

4.2 Changing the material feed pump position



Be careful, as the moving parts of the swivel mechanism can crush fingers and feet.

1. Grip handle (fig. 11, item 1) with one hand.
2. Push locking pin (2) with the other hand.
3. Swivel material feed pump up or down to the desired position, until the locking pin (2) locks into the new position.

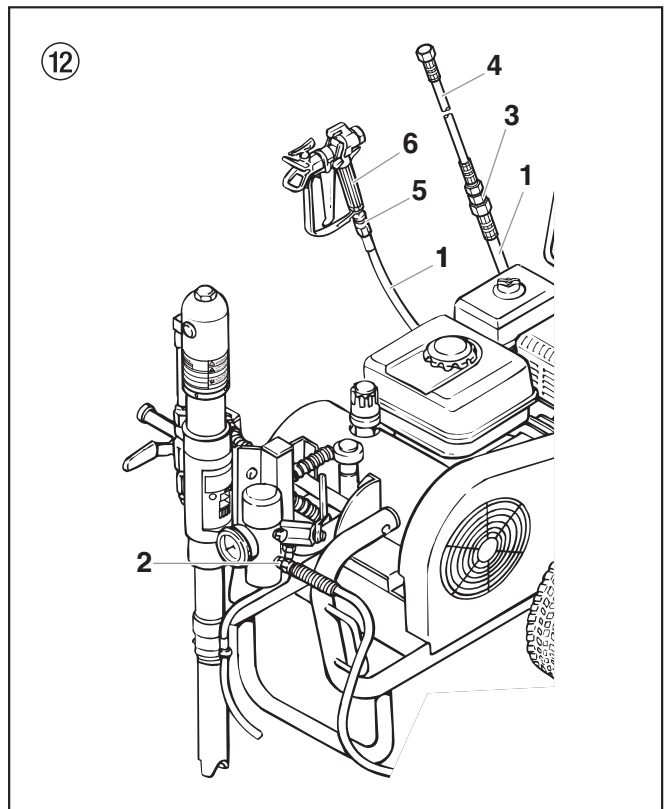
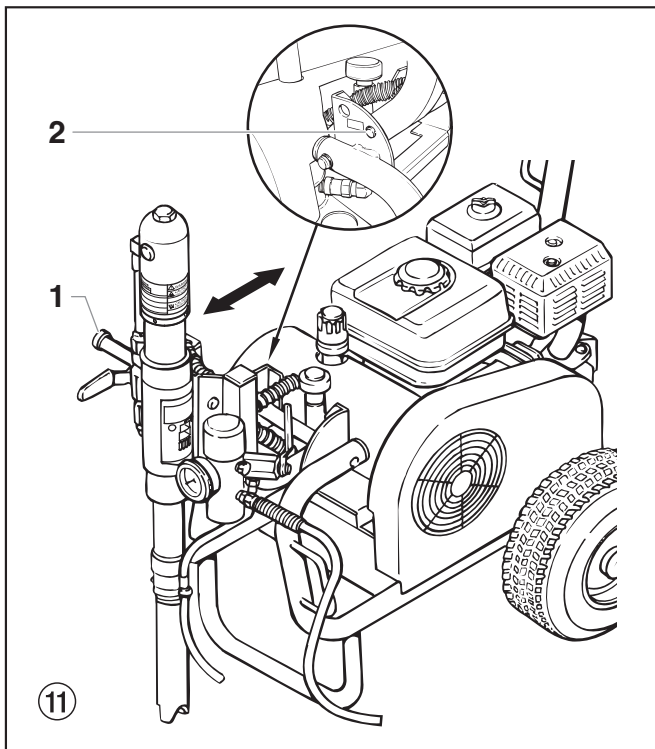

4.3 High-pressure hose, spray gun and separating oil

1. Screw the high-pressure hose (fig. 12, item 1) onto the hose connection (2).
2. Screw HC 940-SSP • HC 960 and HC 960-SSP double socket (3) into the high-pressure hose. Screw on hose whip (4).
3. Screw connection socket (5) to the spray gun (6).
4. Screw spray gun with selected tip to the high-pressure hose or hose whip (4), depending on the model.
5. Tighten union nuts at high-pressure hose and, depending on the model, at the hose whip to prevent coating material from leaking.

6. Fill in EasyGlide (fig. 13). Do not fill in too much separating oil, i.e. ensure that no separating oil drips into the coating material container.



Attention

EasyGlide prevents increased wear and tear to the packings.

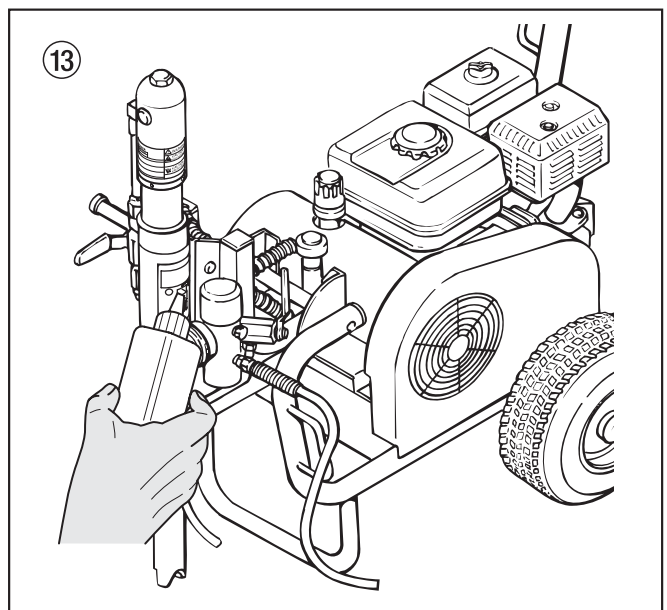

4.4 Gasoline engine (gas units only)

1. Fill in the supplied engine oil.
The gasoline engine is transported without engine oil. The oil-level sensor prevents the engine from being started when the oil level is too low. For oil grades and quantities please refer to the engine instructions.
2. Fill the gasoline tank.
For information on the gasoline please refer to the engine instructions.

4.5 Connection to the mains (electric units only)



The connection must take place through a properly earthed two-pole and earth socket outlet.

Before connecting the unit to the mains supply, make sure that the line voltage matches the specifications on the unit's rating plate.

The green indicator light will light up as soon as the mains plug has been connected.

4.6 Cleaning preserving agent when starting-up of operation initially

1. Push locking pin (fig. 14, item 1) and swivel material feed pump to a container with suitable cleaning agent.
2. Turn the pressure control knob (2) on the hydraulic pump to the left (pressure reduction) until it stops.
3. Turn the relief valve handle (3) fully counterclockwise (↺ Circulation).
4. Start the engine or turn on the electric motor.
 - a. To start the gas engine, refer to the engine manual.
 - b. To start the electric motor:
 - For HC 920 and HC 940 units, move the switch to "1" (ON).
 - For HC 960 units, first set the switch to "Y" and then to "Δ" (ON).



The direction of the rotation of the pulley must correspond to the arrow (4) on the belt cover. If the belt is running opposite the direction of the arrow: Switch unit to "O" (OFF). Unplug power plug and turn the polarity changer (5) in the power plug by 180° with a screwdriver. Plug in power plug again.

5. Move the hydraulic ball valve (6) on the material feed pump to its vertical position (open). This will switch on the hydraulic motor.
Hydraulic oil flows to the hydraulic motor of the material feed pump.
6. Turn the pressure control knob (2) to the right (pressure increase) until cleaning agent exits the return hose.
7. Turn relief valve handle (3) fully clockwise (↻ spray).
8. Pull the trigger of the spray gun.
9. Spray the cleaning agent from the unit into an open collecting container.

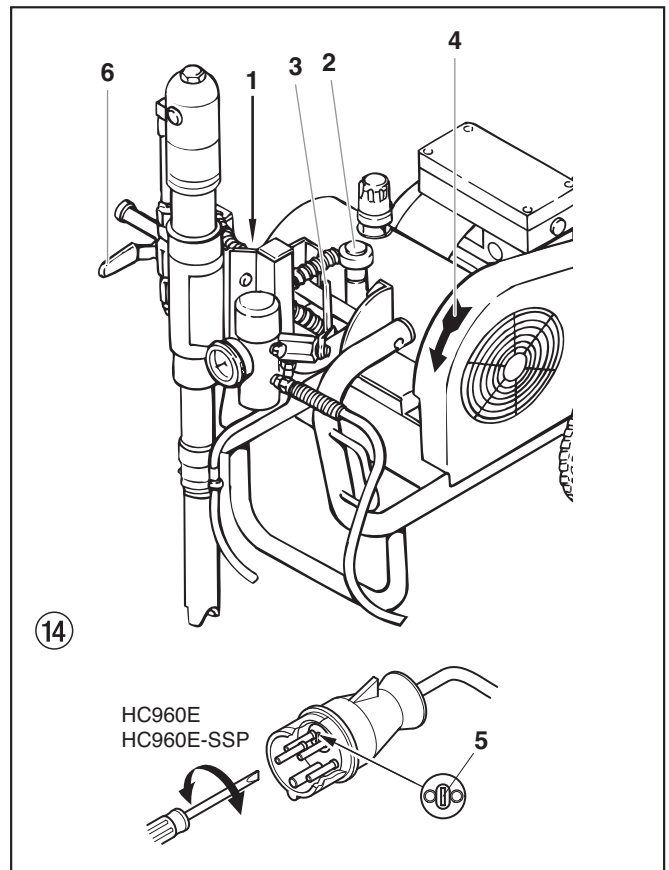

4.7 Taking the unit into operation with coating material



If the unit is located on a non-conductive surface (e.g. a wood floor), earth the unit with an earthing cable.

1. Push locking pin (fig. 14, item 1) and swivel material feed pump into the coating material container.
2. Turn the pressure control knob (2) on the hydraulic pump to the left (pressure reduction) until it stops.
3. Turn the relief valve handle (3) fully counterclockwise (↺ Circulation).
4. Start the engine or turn on the electric motor.
 - a. To start the gas engine, refer to the engine manual.
 - b. To start the electric motor:
 - For HC 920 and HC 940 units, move the switch to "1" (ON).
 - For HC 960 units, first set the switch to "Y" and then to "Δ" (ON).



The direction of the rotation of the pulley must correspond to the arrow (4) on the belt cover. If the belt is running opposite the direction of the arrow: Switch unit to "O" (OFF). Unplug power plug and turn the polarity changer (5) in the power plug by 180° with a screwdriver. Plug in power plug again.

5. Move the hydraulic ball valve (6) on the material feed pump to its vertical position (open). This will switch on the hydraulic motor.
Hydraulic oil flows to the hydraulic motor of the material feed pump.
6. Turn the pressure control knob (2) to the right (pressure increase) until coating material exits the return hose.
7. Turn relief valve handle (3) fully clockwise (↻ spray).
8. Pull the trigger of the spray gun, then set the desired operating pressure by means of the pressure control knob (2).
9. The unit is ready to spray.

5. Spraying technique

Move the spray gun evenly during the spraying process. Otherwise the spray pattern will be uneven. Carry out the spray movement with the arm, not with the wrist. Observe a parallel distance of approx. 30 cm between the spray gun and the object of spraying. The lateral edge of the spray jet should not be too distinct. The spray edge should be gradual in order to facilitate overlapping of the next coat. Always move the spray gun parallel and at an angle of 90° to the surface to be coated in order to minimize the paint mist.



If very sharp edges result or if there are streaks in the spray jet – increase the operating pressure or dilute the coating material.

6. Handling the high-pressure hose

Avoid sharp bending or kinking of the high-pressure hose. The smallest bending radius amounts to about 20 cm.

Do not drive over the high-pressure hose. Protect against sharp objects and edges.



Danger of injury through leaking high-pressure hose. Replace any damaged high-pressure hose immediately.
Never repair defective high-pressure hoses yourself!

6.1 High-pressure hose

The unit is equipped with a high-pressure hose specially suited for piston pumps.



Use only WAGNER original-high-pressure hoses in order to ensure functionality, safety and durability.

7. Interruption of work

1. Move the hydraulic ball valve on the material feed pump to its horizontal position (closed).
Flow of hydraulic oil to hydraulic motor of material feed pump is interrupted.
2. Turn the relief valve handle (3) fully counterclockwise (↺ Circulation).
3. Turn off the gasoline engine or electric motor.
4. Pull the trigger of the spray gun in order to release the pressure from the high-pressure hose and spray gun.
5. Secure the spray gun, refer to the operating manual of the spray gun.
6. If a standard tip is to be cleaned, see page 57, point 13.2. If a non-standard tip is installed, proceed according to the relevant operating manual.
7. Leave the suction tube immersed in the coating material or immerse it in the corresponding cleaning agent.



If fast-drying or two-component coating material is used, ensure that the unit is rinsed with a suitable cleaning agent within the processing time.

8. Cleaning the unit (shutting down)

A clean state is the best method of ensuring operation without problems. After you have finished spraying, clean the unit. Under no circumstances may any remaining coating material dry and harden in the unit.

The cleaning agent used for cleaning (only with an ignition point above 21 °C) must be suitable for the coating material used.

- Secure the spray gun, refer to the operating manual of the spray gun.

Clean and remove tip.

For a standard tip, refer to page 57, point 13.2.

If a non-standard tip is installed, proceed according to the relevant operating manual.

1. Push locking pin and swivel material feed pump out of coating material.
2. Pull the trigger of the spray gun in order to pump the remaining coating material from the suction tube, high-pressure hose and the spray gun into an open container.



The container must be earthed in case of coating materials which contain solvents.



Caution! Do not pump or spray into a container with a small opening (bunghole)! Refer to the safety regulations.

3. Push locking pin and swivel material feed pump to a container with suitable cleaning agent.
4. Turn the relief valve handle (3) fully counterclockwise (↺ Circulation).
5. Pump a suitable cleaning agent in the circuit for a few minutes.
6. Turn relief valve handle (3) fully clockwise (↻ spray).
7. Pump the remaining cleaning agent into an open container until the unit is empty.
8. Turn the relief valve handle (3) fully counterclockwise (↺ Circulation).

9. Move the hydraulic ball valve on the material feed pump to its horizontal position (closed).
10. Turn off the gasoline engine or electric motor.

8.1 Cleaning the unit from the outside



Gasoline units — Switch off the gasoline engine and let it cool down.

Electric units — Unplug the mains plug from the socket.



Danger of short-circuits through penetrating water.

Never spray down the unit with high-pressure or high-pressure steam cleaners.

Wipe the unit off with a cloth soaked in a suitable cleaning agent.

8.2 Suction filter on HC 920



A clean suction filter always guarantees maximum feed quantity, constant spraying pressure and problem-free functioning of the unit.

- Screw off the filter (fig. 15) from suction pipe.
- Clean or replace the filter.

Carry out cleaning with a hard brush and an appropriate cleaning agent.

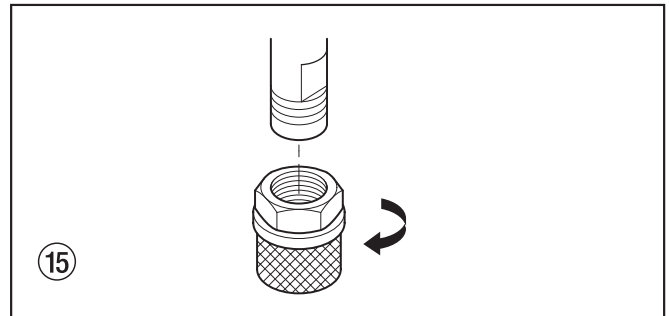

8.3 Cleaning the high-pressure filter

Clean the filter cartridge regularly.

A soiled or clogged high-pressure filter can cause a poor spray pattern or a clogged tip.

Disassembly

1. Move the hydraulic ball valve on the material feed pump to its horizontal position (closed).
Flow of hydraulic oil to hydraulic motor of material feed pump is interrupted.
2. Turn the relief valve handle (3) fully counterclockwise (k Circulation).
3. Turn off the gasoline engine or electric motor.
4. Unscrew the housing cover (fig. 16, item 1).
5. Pull filter cartridge (3) out of housing (8).
6. Clean the pressure spring (2) and filter cartridge (3) with an appropriate cleaning agent, clean the inside of the housing (8) and housing cover (1).
7. Check ball in the filter cartridge (3) for wear and replace filter cartridge, if necessary.
8. If ball in filter cartridge (3) is thoroughly worn, remove O-ring (6) and valve seat (7). Replace worn valve seat, if necessary.
9. **Always replace O-ring (6) after removal.**
10. Pull off pressure spring (2) from housing cover (1).
Measure length of pressure spring, and replace if shorter than 19 mm.

Assembly

1. Insert valve seat (7) with the ball seat surface facing up into the housing (8).
2. Insert O-ring (6) into the housing (8).
3. Insert filter cartridge (3).
4. Place thin seal (5) on threaded section of housing (8).
5. Place thick seal (4) on top of thin seal (5).
6. Slide pressure spring (2) onto housing cover pin (2).
7. Screw on housing cover (1) and tighten by hand.

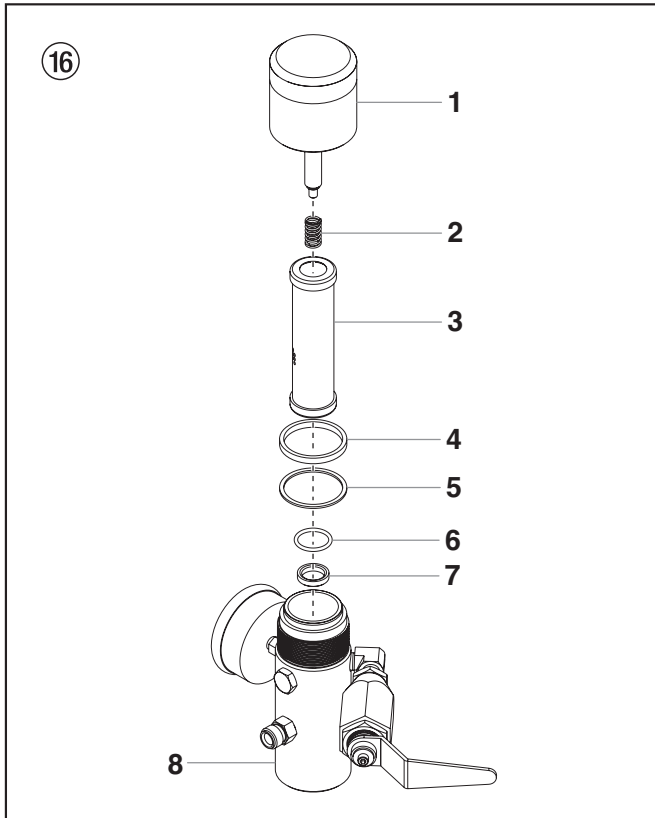

8.4 Cleaning Airless spray gun

- Rinse Airless spray gun with an appropriate cleaning agent.
- Clean tip thoroughly with appropriate cleaning agent so that no coating material residue remains.
- Thoroughly clean the outside of the Airless spray gun.

Intake filter in Airless spray gun

Dismounting (fig. 17)

1. Pull protective guard (1) forward vigorously.
2. Screw handle (2) out of the gun housing. Remove intake filter (3).
3. Intake filter congested or defective – replace.

Mounting

1. Place intake filter (3) with the long cone into the gun housing.
2. Screw handle (2) into the gun housing and tighten.
3. Snap in protective guard (1).

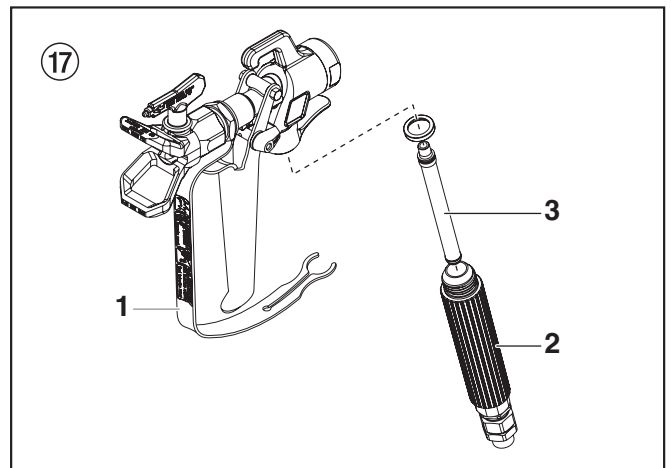

9. Remedy in case of faults

9.1 Gasoline engine

Type of malfunction	Possible cause	Measures for eliminating the malfunction
A. Gasoline engine does not start up	<ol style="list-style-type: none"> 1. No gasoline. 2. ON/OFF switch to OFF. 3. Gasoline cock closed. 4. Engine problem. 5. Engine defective. 6. Oil level insufficient. 	<ol style="list-style-type: none"> 1. Fill the gasoline tank. 2. Move the switch to ON. 3. Open the gasoline cock. 4. Please refer to the engine instructions. 5. Bring to the Honda service point. 6. Top off oil.

9.2 Electric Motor

Type of malfunction	Possible cause	Measures for eliminating the malfunction
A. Unit does not start	<ol style="list-style-type: none"> 1. Indicator light does not indicate unit has power. 2. The unit has switched off automatically because of an overload. 	<ol style="list-style-type: none"> 1. Check power supply. 2. Wait 2 – 3 minutes, then turn the unit back on.
B. HC 960 units: Piston rod in the material feed pump is not moving up and down.	<ol style="list-style-type: none"> 1. Direction of the rotation of the electric motor is incorrect 	<ol style="list-style-type: none"> 1. Turn the polarity changer in the power plug 180°.

9.3 Hydraulic motor

Type of malfunction	Possible cause	Measures for eliminating the malfunction
A. Hydraulic motor stuck in the lower position.	<ol style="list-style-type: none"> 1. Outlet valve seat in the material feed pump is loose. 2. Reversing valve in the hydraulic motor is stuck or the upper or lower hexagonal nut on the valve rod has become loose. 	<ol style="list-style-type: none"> 1. Ball valve on the material feed pump – lever position vertical. Screw out sealing screw on hydraulic motor. Press down reversing valve on hydraulic motor. Remount sealing screw. Start unit. The piston rod moves upward and then gets stuck in the lower position. The cause is a loose outlet valve seat. 2. Take unit to a Wagner authorized service center.
B. Hydraulic motor stuck in the upper position.	<ol style="list-style-type: none"> 1. Reversing valve is stuck. 2. Pressure spring on valve rod is broken. 3. Pressure spring stop on valve rod is broken. 4. Air in the hydraulic motor. 5. Air in the material feed pump. 	<ol style="list-style-type: none"> 1. Take unit to a Wagner authorized service center. 2. Take unit to a Wagner authorized service center. 3. Take unit to a Wagner authorized service center. 4. Turn back pressure control knob. Vent air at low pressure during a 5 – 10 minute endurance run. Do not let the material feed pump run dry. Check for leaks: • Loose connections on hydraulic oil tank • Loose connections on the hydraulic oil pump • Loose hydraulic oil hose connections • Level of oil in hydraulic tank is too low 5. Ball valve on the material feed pump – lever position vertical. Screw out sealing screw on hydraulic motor. Press down reversing valve on hydraulic motor. Remount sealing screw. Start unit. Prevent the material feed pump from sucking up air.
C. Low pressure. The piston rod moves correctly in the downward stroke, but the upward stroke is sluggish. The outside of the hydraulic motor is very hot.	<ol style="list-style-type: none"> 1. Faulty piston packing in hydraulic motor. 2. Piston rod is broken. 	<ol style="list-style-type: none"> 1. Take unit to a Wagner authorized service center. 2. Take unit to a Wagner authorized service center.
D. Low pressure. The outside of the hydraulic motor becomes very hot when stroking upward and downward.	<ol style="list-style-type: none"> 1. Middle O-ring on reversing valve is faulty. 2. Packings in the material feed pump are worn. 	<ol style="list-style-type: none"> 1. Take unit to a Wagner authorized service center. 2. Replace

9.4 Material feed pump

Type of malfunction	Possible cause	Measures for eliminating the malfunction
A. A sufficient amount of coating material is ejected only with an upward stroke, or upward motion of the piston rod is slow and downward motion is fast	<ol style="list-style-type: none"> Inlet valve is leaky due to impurities or wear. Coating material viscosity is too high, preventing it from being sucked up. 	<ol style="list-style-type: none"> Clean and check the inlet valve housing. Insert ball and fill with water; if leaky, replace ball. Thin out according to the manufacturer's instructions.
B. A sufficient amount of coating material is ejected only with a downward stroke, or downward motion of the piston rod is slow and upward motion is fast.	<ol style="list-style-type: none"> Outlet valve leaky. Lower packing is worn. 	<ol style="list-style-type: none"> Dismantle and check outlet valve seat. Insert ball and fill with water; if leaky, replace ball. Replace.
C. Piston rod moves up and down quickly.	<ol style="list-style-type: none"> Suction tube projects over the fluid level and sucks in air. Coating material viscosity is too high, preventing it from being sucked up. Ball in inlet valve housing is stuck. 	<ol style="list-style-type: none"> Refill the coating material Thin out the coating material according to manufacturer's instructions. Vent air from material feed pump and turn the relief valve knob to the left (↺ Circulation).
D. Piston rod moves up and down slowly when the spray gun is closed.	<ol style="list-style-type: none"> Loose connections. Relief valve is not closed completely. Relief valve worn. Lower packing worn. Ball in inlet valve housing and ball in outlet valve seat are not sealing properly. 	<ol style="list-style-type: none"> Dismantle inlet valve housing, clean ball and valve seat. Check all connections between the material feed pump and spray gun. Turn relief valve handle (3) fully clockwise (↻ spray). Replace If the measures described above do not help, replace lower packing. Dismantle inlet valve housing and outlet valve seat. Clean balls and valve seats.
E. Not enough pressure to the spray gun.	<ol style="list-style-type: none"> Tip is worn. Filter cartridge in high-pressure filter is clogged. High-pressure hose is too long. 	<ol style="list-style-type: none"> Replace Clean or replace the filter cartridge. Reduce length.
F. Piston rod sputters when stroking upward or downward.	<ol style="list-style-type: none"> Solvent has made the upper packing expand. 	<ol style="list-style-type: none"> Replace upper packing.

10. Servicing

10.1 General servicing

The unit should be serviced once a year by the Wagner Service.

1. For servicing of the gasoline engine, refer to the engine instructions.
2. Check the high-pressure hoses for damage.
3. Check the inlet and outlet vents for wear.
4. Check oil level in hydraulic oil tank.
5. Carry out an oil change if necessary.

10.2 Checking the oil level in the hydraulic oil tank



Gasoline units — Check oil level daily.



Electric units — Switch off unit "O" (OFF). Remove the mains plug from the socket.

1. Turn oil measuring stick (fig. 18, item 1) to the left and pull out.
2. The oil level should be visible between the marking (see arrows) on the oil measuring stick.
3. If necessary, refill oil. For information on the oil grade, refer to the oil change section, chapter 10.3.

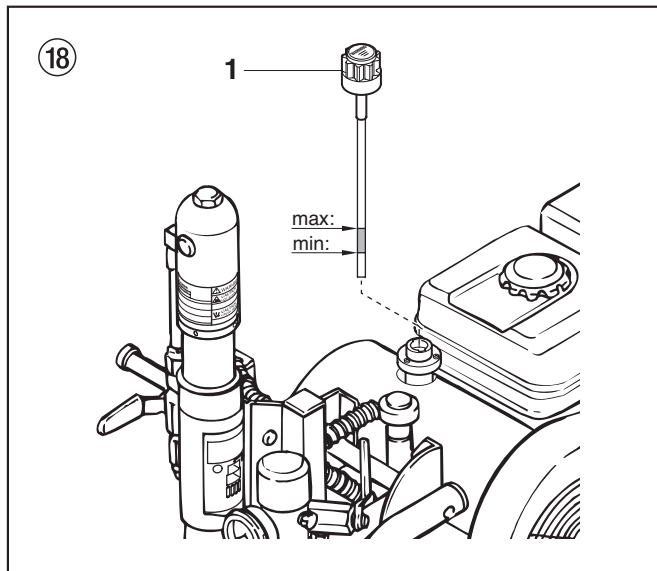

10.3 Oil and oil filter change of the hydraulic oil pump

Carry out oil and oil filter change once every 12 months.



Danger to the environment
Do not dispose of waste oil into the sewer or soil. Polluting the ground water is a crime. Waste oil can be returned where hydraulic oil is bought.



Carry out an oil change while the unit is still warm from operation.



Electric units — Switch off unit "O" (OFF). Remove the mains plug from the socket.

1. Turn off the gasoline engine or electric motor.
2. Move the hydraulic ball valve (fig. 19, item 1) on the material feed pump to its vertical position (open).
3. Remove the screws on the hydraulic oil pump cover (2) and remove cover.
4. Turn oil measuring stick (3) to the left and pull out.
5. Screw out oil filter (4) with a strap spanner and replace.
6. Screw out sealing screw (5) under the hydraulic oil tank. Drain the waste oil.
7. Replace the sealing screw into the hydraulic oil tank.
8. Fill in 4.7 liters of ESSO NUTO H 32 hydraulic oil.



When oil is filled in, air can enter the hydraulic system. Therefore, the system must be vented.

9. Let the unit run for at least five minutes at low pressure to automatically bleed the air from the hydraulic system.

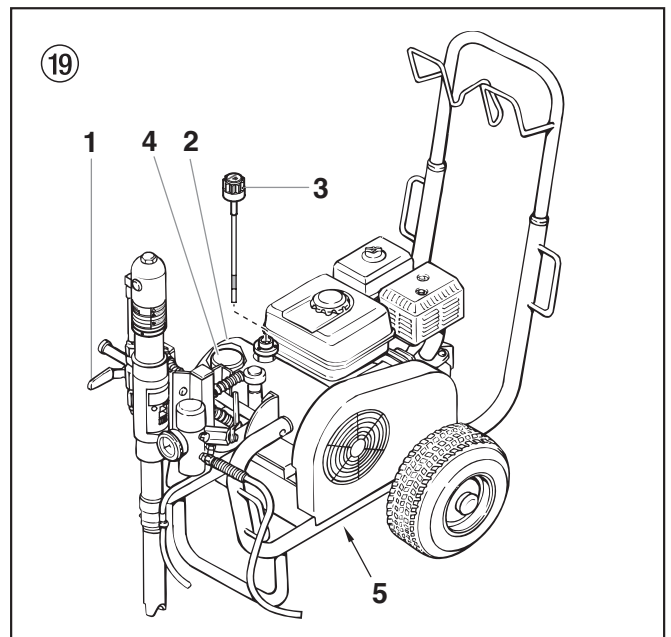

10.4 High-pressure hose

Inspect the high-pressure hose visually for any notches or bulges, in particular at the transition in the fittings. It must be possible to turn the union nuts freely.

11. Standard equipment of HC units

Item	HC 920 Order No.	HC 940 Order No.	HC 940-SSP Order No.	HC 960 Order No.	HC 960-SSP Order No.	Description
1	0502 166	0502 166	0502 166	0502 166	0502 166	Spray gun AG 14, F-thread
	0502 119	0502 119	0502 119	0502 119	0502 119	Spray gun AG 14, G-thread
2	0556 042	0556 042	0556 042	0556 042	0556 042	TradeTip 2 tip holder F
	0556 041	0556 041	0556 041	0556 041	0556 041	TradeTip 2 tip holder G
3	0552 427	0552 427	_____	_____	_____	Wagner TradeTip 2
	_____	_____	0552 433	0552 433	0552 433	Wagner TradeTip 2
	_____	_____	0552 243	_____	0552 243	Wagner TradeTip 2
4	0179 732	0179 732	0179 732	0179 732	0179 732	Connection socket, 1/4" x 3/8"
5	_____	_____	0528 127	0528 127	0528 127	Hose whip DN 10 mm, 2.5 m, NPSM 3/8
6	_____	_____	3203 026	3203 026	3203 026	Double socket 3/8 inch – 1/2 inch
	_____	_____	9985 783	9985 783	9985 783	Double socket 3/8 inch – 3/4 inch
	_____	_____	9985 782	9985 782	9985 782	Double socket 1/2 inch – 3/4 inch
7	0528 125	0528 125	_____	_____	_____	Special high-pressure hose DN 10 mm, 15 m, NPSM 3/8 inch
	_____	_____	0528 126	0528 126	0528 126	Special high-pressure hose DN 13 mm, 15 m, NPSM 1/2 inch
	_____	_____	9984 571	9984 571	9984 571	Special high-pressure hose DN 19 mm, 15 m, NPSM 3/4 inch
8	_____	_____	9985 783	9985 783	9985 783	Double socket 3/8 inch – 3/4 inch (for high-pressure filter)

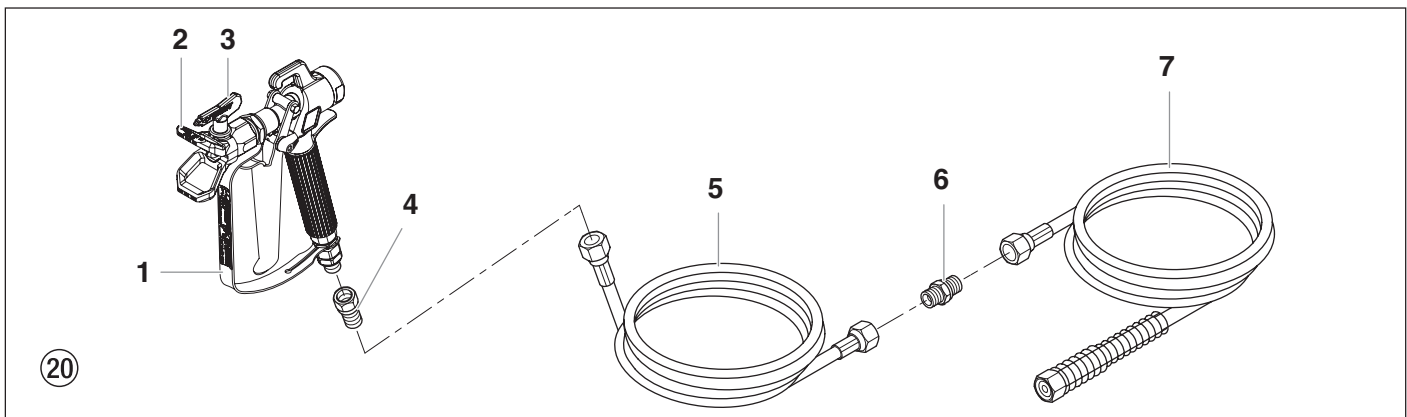

12. Accessories and spare parts

12.1 Accessories for HC units (accessories illustration, see page 120)

Item	HC 920 Order No.	HC 940 Order No.	HC 940-SSP Order No.	HC 960 Order No.	HC 960-SSP Order No.	Description
1	0096 019 0096 005 0096 006	0096 019 0096 005 0096 006	0096 019 0096 005 0096 006	0096 019 0096 005 0096 006	0096 019 0096 005 0096 006	Pole gun 100 cm Pole gun 150 cm Pole gun 270 cm
2	—	—	—	—	—	High-pressure hoses and connection sockets, see under 11. Standard equipment HC units
3	0256 343 — —	0256 343 — —	— 3202 901 9985 781	— 3202 901 9985 781	— 3202 901 9985 781	Double socket NPSM 3/8 inch (for hose extension) Double socket 1/2 inch (for hose extension) Double socket 3/4 inch (for hose extension)
4	0268 905	0268 905	0268 905	0268 905	0268 905	Texture tip set 4, 6, 8, 10 mm
5	0258 202 0258 720	0258 202 0258 720	0258 202 0258 720	0258 202 0258 720	0258 202 0258 720	Spray head for working with Airless filler (sprinkle texture) with air support Sprinkle texture set: Spray head, texture tip set, tip-cleaning needle and air hose DN 9 mm, 15 m with rapid action coupling (no. fig.)
6	0345 010	0345 010	0345 010	0345 010	0345 010	In-line roller IR-100
7	— —	0349 907 —	0349 907 9991 651	0349 907 —	0349 907 9991 651	Container suction system, hose diameter 50 mm Reduction adapter B- to C- coupling
8	—	0258 712	—	0258 712	—	Dispersion system
9	—	0258 715	—	0258 715	—	Plaster system
10	—	—	0349 910	—	0349 910	Container – Spacspray (plaster)

12.2 Spare parts list for the material feed pump HC 920 (spare parts diagram, see page 121)

Item	Order No.	Description	Item	Order No.	Description
1	0349 473	Cover (2)	16	0349 503**(**)	O-ring (2)
2	0349 472	Screw (2)	17	0349 508*	Cylinder
3	0349 406**(**)	Spiral ring	18	0349 502**(**)	O-ring
4	0349 506	Connection pin	19	0528 071	Wave washer
5	0349 612	Adapter	20	0528 080	Ball cage
6	0349 238**(**)	Packing, complete (2)	21	0349 509**(**)	Ball
7	0349 498	Conical spring	22	0509 592*	Inlet valve seat
8	0349 507*	Piston rod	23	0509 582**(**)	Seat o-ring
9	0349 493	Spring plate	24	0528 009	Inlet valve housing
10	0349 505**(**)	Bushing	25	0507 782	Suction tube
11	0349 504	Pressure spring	26	0349 602	Filter, 10 meshes
12	0349 519**(**)	Ball			
13	0555 651*	Outlet valve seat		0528 105*	Service set: Major
14	0555 652**(**)	Seal washer		0528 104**	Service set: Minor
15	0555 653	Outlet valve housing		9992 504	250 ml separating oil (Mesamoll)

12.3 Spare parts list for the material feed pump HC 940 • HC 940-SSP • HC 960 • HC 960-SSP

(spare parts diagram, see page 121)

Item	HC 940 Order No.	HC 940-SSP Order No.	HC 960 Order No.	HC 960-SSP Order No.	Description
1	0349 473	0349 473	0349 473	0349 473	Cover (2)
2	0349 472	0349 472	0349 472	0349 472	Screw (2)
3	0349 406(**)	0349 406(**)	0349 406(**)	0349 406(**)	Spiral ring
4	0349 407	0349 407	0349 407	0349 407	Connection pin
5	0349 612	0349 612	0349 612	0349 612	Adapter
6	0349 409(**)	0349 409(**)	0349 409(**)	0349 409(**)	Packing, complete (2)
7	0349 410	0349 410	0349 410	0349 410	Conical spring
8	0349 596*	0349 596*	0349 411*	0349 411*	Piston rod
9	0349 412	0349 412	0349 412	0349 412	Flange bushing
10	0349 413	0349 413	0349 413	0349 413	Pressure spring
11	0349 622(**)	0349 622(**)	0349 622(**)	0349 622(**)	Ball cage
12	0349 414(**)	0349 414(**)	0349 414(**)	0349 414(**)	Ball
13	0555 668*	0555 668*	0555 668*	0555 668*	Outlet valve seat
14	0555 669(**)	0555 669(**)	0555 669(**)	0555 669(**)	Seal washer
15	0555 670	0555 670	0555 670	0555 670	Outlet valve housing
16	0349 408(**)	0349 408(**)	0349 408(**)	0349 408(**)	O-ring (2)
17	0349 606*	0349 606*	0349 416*	0349 416*	Cylinder
18	0349 417(**)	0349 417(**)	0349 417(**)	0349 417(**)	O-ring
19	0528 081	0528 081	0528 081	0528 081	Wave washer
20	0555 672	—————	0555 672	—————	Ball cage
21	0509 707(**)	—————	0509 707(**)	—————	Ball
22	0509 623*	0509 623*	0509 623*	0509 623*	Inlet valve seat
23	0509 708(**)	0509 708(**)	0509 708(**)	0509 708(**)	Seat o-ring
24	0528 011	—————	0528 011	—————	Inlet valve housing
25	0349 300	—————	0349 300	—————	Suction tube
	0528 102*	0528 102*	0528 103*	0528 103*	Service set: Major
	0528 101**	0528 101**	0528 101**	0528 101**	Service set: Minor
	9992 504	9992 504	9992 504	9992 504	250 ml separating oil (Mesamoll)

12.4 Spare parts list for the shovel valve

HC 940-SSP • HC 960-SSP

(spare parts diagram, see page 122)

Item	Order No.	Description	Item	Order No.	Description
1	9907 195	Hex screw (4)	21	9910 712	Cap nut M 6 (2)
2	9920 102	Washer (4)	22	9923 501	Disk spring (4)
3	9900 513	Screw	23	0349 690	Connection element
4	0349 683	Pressure plate	24	9910 113	Hexagon nut M 6
5	0349 684	Plug plate	25	0349 551	Flat perforated screw
6	0367 525	O-ring (2)	26	9923 504	Disk spring
7	0349 685	Sealing ring	27	0349 576	Packing, complete
8	0349 556	Ball cage	28	3053 865	Retaining ring
9	0037 776	Pressure spring	29	0349687	Insert
10	9941 537	Ball	30	9971 353	O-ring 21 x 2
11	0349 557	Ball seat	31	0349 408	O-ring 50 x 1.78
12	9930 411	Grooved pin	32	0349 686	Groove nut
13	9906 025	Head cap screw	33	0349 682	Inlet valve housing
14	9971 009	O-ring	34	9971 489	O-ring 47 x 2.5
15	0349 555	Plug	35	0349 545	Rod
16	0349 152	Plug assembly	36	9920 311	Washer
17	0349 688	Sealing plug with adapter	37	0349 544	Shovel valve plate
18	9971 148	O-ring	38	0349 543	Shovel valve
19	9941 501	Ball	39	0349 580	Suction tube
20	0349 151	Outlet valve assembly			
				0349 150	Shovel valve assembly

**12.5 Spare parts list for the high-pressure filter**

(spare parts diagram, see page 123)

Item	HC 920	HC 940	HC 940-SSP	Description
	Order No.	Order No.	Order No.	
1+	0349 429	0349 429	0349 429	Housing cover
2+	0349 430*	0349 430*	0349 430*	Pressure spring
3+	0349 707	0349 707	0349 707	Filter cartridge 0 meshes (standard equipment)
	0349 431	0349 431	0349 431	Filter cartridge 5 meshes (accessories)
	0349 704	0349 704	0349 704	Filter cartridge 50 meshes (accessories)
	0349 705	0349 705	0349 705	Filter cartridge 100 meshes (accessories)
4+	0349 432*	0349 432*	0349 432*	Seal thick
5+	0349 433*	0349 433*	0349 433*	Seal thin
6+	0349 434*	0349 434*	0349 434*	O-ring
7+	0349 435	0349 435	0349 435	Valve seat
8	0528 161	0528 161	0528 161	Manometer
9+	0349 436	0349 436	0349 436	Housing
10+	0349 438	0349 438	0349 438	Sealing screw
11	0349 439	0349 439	_____	Double socket NPSM 3/8 inch
			0349 610	Double socket NPSM 3/8 inch
12+	0528 082	0528 082	0528 082	Elbow, 90°
13	0555 645	0555 645	0555 645	Relief valve
14+	0556 101	0556 101	0556 101	Swivel adapter
15	0528 034	0528 034	0528 034	Return hose
16	0528 095	9850 639	9850 639	Hose clamp
	0349 700*	0349 700*	0349 700*	Service set: high-pressure filter
	0528 935+	0528 935+	0528 935+	Service set: filter body assembly

12.6 Spare parts list for the hydraulic system (HC 920 · HC 940 · HC 940-SSP · HC 960)

(spare parts diagram, see page 124)

Item	HC 920	HC 940 HC 940-SSP HC 960	Description
	Order No.	Order No.	
1	0349 358	0349 358	Pressure hose
2	0349 487	0349 487	Angle
3	0349 339	0349 339	Connection nipple
4	0349 337	0349 337	Tube
5	0349 338	0349 338	Hose clamp
6	0349 340	0349 340	Angle
7	0349 341	0349 341	Pressure control knob
8	0349 490	0349 455	Hydraulic oil pump
9	0349 456	0349 456	Feather key
10	0349 345	0349 345	Securing screw
11	0349 483	0349 344	Pulley
12	0349 360	0349 360	O-ring
13	0349 302	0349 302	Hexagonal bolt (8)
14	0349 303	0349 303	Lock washer (10)
15	0528 160	0528 160	Oil tank cover
16	0349 348	0349 348	Countersunk bolt (2)
17	0349 347	0349 347	Washer (2)
18	0349 349	0349 349	Screw (2)
19	0349 350	0349 350	Seal
20	0349 374	0349 374	Tightening nut
23	0349 351	0349 351	Double nipple
24	0349 352	0349 352	Angle
25	0349 353	0349 353	Filter
26	0349 458	0349 458	Securing nut (2)
27	0254 426	0254 426	Washer (5)
28	0349 480	0349 480	Hexagonal bolt (3)
29	0349 484	0349 484	Sealing screw
30	0349 302	0349 302	Hexagonal bolt
31	0349 485	0349 485	Hydraulic oil tank
32	0349 371	0349 371	Distance washer
33	0349 370	0349 370	Bolt
34	0349 369	0349 369	Cap nut
35	0349 368	0349 368	Wing screw
36	0349 356	0349 356	Return hose
37	0349 465	0349 465	Angle 45°
38	0349 463	0349 463	Adapter
39	0349 361	0349 361	Earthing bar
40	0349 373	0349 373	Bypass valve
41	0349 468	0349 468	Filter
42	0349 467	0349 467	Filler neck
43	0349 614	0349 614	Oil measuring stick
44	0349 521	0349 521	Ball valve
45	0528 096	0528 096	Swivel fitting
46	0555 968	0555 969	Controller
47	0349 616	0349 616	Label
48	0349 492	0349 492	Securing screw

Spare parts list for the hydraulic system (HC 960-SSP)

(spare parts diagram, see page 125)

Item	HC 960-SSP	Description
	Order No.	
1	0349 358	Pressure hose
2	0349 487	Angle
3	0349 339	Connection nipple
4	0349 337	Tube
5	0349 338	Hose clamp
6	0349 340	Angle
7	0349 341	Pressure control knob
8	0349 455	Hydraulic oil pump
10	0349 345	Securing screw
11	0349 344	Pulley
12	0349 360	O-ring
13	0349 302	Hexagonal bolt (8)
14	0349 303	Lock washer (10)
15	0528 314	Oil tank cover
16	0349 348	Countersunk bolt (2)
17	0349 347	Washer (2)
18	0349 349	Screw (2)
19	0349 350	Seal
20	0349 374	Tightening nut
23	0528 171	Double nipple
24	0349 352	Angle
25	0349 353	Filter
26	0349 458	Securing nut (2)
27	0254 426	Washer (5)
28	0349 480	Hexagonal bolt (3)
29	0349 484	Sealing screw
30	0349 302	Hexagonal bolt
31	0349 485	Hydraulic oil tank
32	0349 371	Distance washer
33	0349 370	Bolt
34	0349 369	Cap nut
35	0349 368	Wing screw
36	0349 356	Return hose
37	0349 465	Angle 45°
38	0349 463	Adapter
39	0349 361	Earthing bar
40	0349 373	Bypass valve
41	0349 468	Filter
42	0349 467	Filler neck
43	0349 614	Oil measuring stick
44	0349 521	Ball valve
45	0528 096	Swivel fitting
46	0349 616	Label
47	0349 492	Securing screw



12.7 Spare parts list for units with a gasoline motor

(spare parts diagram, see page 126)

Item	HC 920 Order No.	HC 940 HC 940-SSP Order No.	HC 960 HC 960-SSP Order No.	Description
1	0349 533	_____	_____	Gasoline engine Honda GX 120 K1-QX-4-OH, 3 kW
	_____	0349 589	_____	Gasoline engine Honda GX 160 T1-QX-4-OH, 4.1 kW
	_____	_____	0349 421	Gasoline engine Honda GX 270 K1-QX-4-OH, 6 kW
2	9900 241	9900 241	_____	Hexagon screw M 8 x 40 (4)
	_____	_____	9900 137	Hexagon screw M 10 x 40 (4)
3	3138 808	3138 808	_____	Washer 8.4 (8)
	_____	_____	9920 201	Washer 10.5 (8)
4	0349 537	0349 537	0349 537	Mounting plate
5	9921 601	9921 601	_____	Spring washer 8 (4)
	_____	_____	9921 507	Spring washer A 10 (4)
6	9910 107	9910 107	_____	Hexagonal nut M 8 (4)
	_____	_____	9910 105	Hexagonal nut M 10 (4)
7	0349 587	0528 109	0349 426	V-belt
8	0349 530	0349 591	0349 423	Pulley
9	9931 043	9931 043	0349 422	Key

12.8 Spare parts list for units with an electric motor

(spare parts diagram, see page 127)

Item	HC 920 Order No.	HC 940 HC 940-SSP Order No.	HC 960 HC 960-SSP Order No.	Description
1	0349 592	0349 592	_____	Electric motor 230 V~, 50 Hz
	_____	_____	0349 222	Electric motor 400 V, 50 Hz, V3~
2	9931 039	9931 039	_____	Featherkey 8 x 7 x 25
	_____	_____	9931 042	Featherkey 8 x 7 x 45
3	0349 586	0349 643	0349 535	Pulley
4	_____	0349 644	0349 536	Spring collet
5	0349 587	0349 590	0349 538	Belt
6	9921 601	9921 601	_____	Spring washer 8 (4)
	_____	_____	9921 507	Spring washer A 10 (4)
7	3138 808	3138 808	_____	Screw 8.4 (8)
	_____	_____	9920 201	Screw 10.5 (8)
8	9910 107	9910 107	_____	Hex nut M 8 (4)
	_____	_____	9910 105	Hex nut M 10 (4)
9	0349 537	0349 537	0349 537	Mounting plate
10	9900 241	9900 241	_____	Hex screw M 8 x 40 (4)
	_____	_____	9900 127	Hex screw M 10 x 35 (4)
11	0349 653	0349 653	_____	Housing
12	0349 677	0349 677	_____	Capacitor 60 MF/400-450 V (230 V~, 50 Hz)
13	9953 704	9953 704	_____	ON/OFF switch 230 V~, 50 Hz
	_____	_____	0349 645	ON/OFF switch 400 V, 50 Hz, V3~
14	0349 670	0349 670	0349 670	Control lamp
15	9951 652	9951 652	_____	Power cord H07RN-F3G2.5 – 6m
	_____	_____	0349 259	Power cord H07RN-F5G2.5 – 6 m

12.9 Spare parts list for the carriage

(spare parts diagram, see page 128)

Item	HC 920	HC 960	Description
	HC 940 HC 940-SSP	HC 960-SSP	
	Order No.	Order No.	
1	0528 002	0528 002	Tank cover
2	0509 219	0509 219	Screw (2)
3	0349 303	0349 303	Spring washer (4)
4	0528 090	0528 090	Connector
5	0528 093	0528 093	Washer (2)
6	0528 092	0528 092	Screw (2)
7	0528 093	0528 093	Hexagon nut
8	0507 561	0507 561	Washer
9	0555 449	0555 449	Clip
10	0528 005	0528 021	Belt cover
11	0349 524	0349 541	Lower belt cover
12	0528 088	0528 088	Retaining ring (6)
13	0295 687	0295 687	Washer (4)
14	0528 087	0528 087	Axle
15	0509 239	0509 239	Cotter pin
16	0528 085	0528 085	Stopper (2)
17	0349 324	0349 324	Swing arm handle
18	0349 327	0349 327	Locking pin
19	0349 328	0349 328	Pressure spring
20	0349 480	0349 480	Material feed pump mounting screw
21	0349 362	0349 362	Spring washer
22	0528 086	0528 086	Swing arm
23	0349 302	0349 302	Hex screw (2)
24	0528 089	0528 089	Cart handle
25	9841 504	9841 504	Snap button (2)
26	0295 609	0295 609	Handle washer (2)
27	0295 610	0295 610	Roll pin (2)
28	0295 607	0295 607	Handle sleeve (2)
29	0295 606	0295 606	Lock washer (4)
30	0295 608	0295 608	Screw (4)
31	0528 083	0528 083	Carriage frame
32	0509 390	0509 390	Wheel (2)
33	0528 084	0528 084	Cart handle spacer (not shown)

12.10 Electrical schematic HC920 · HC940

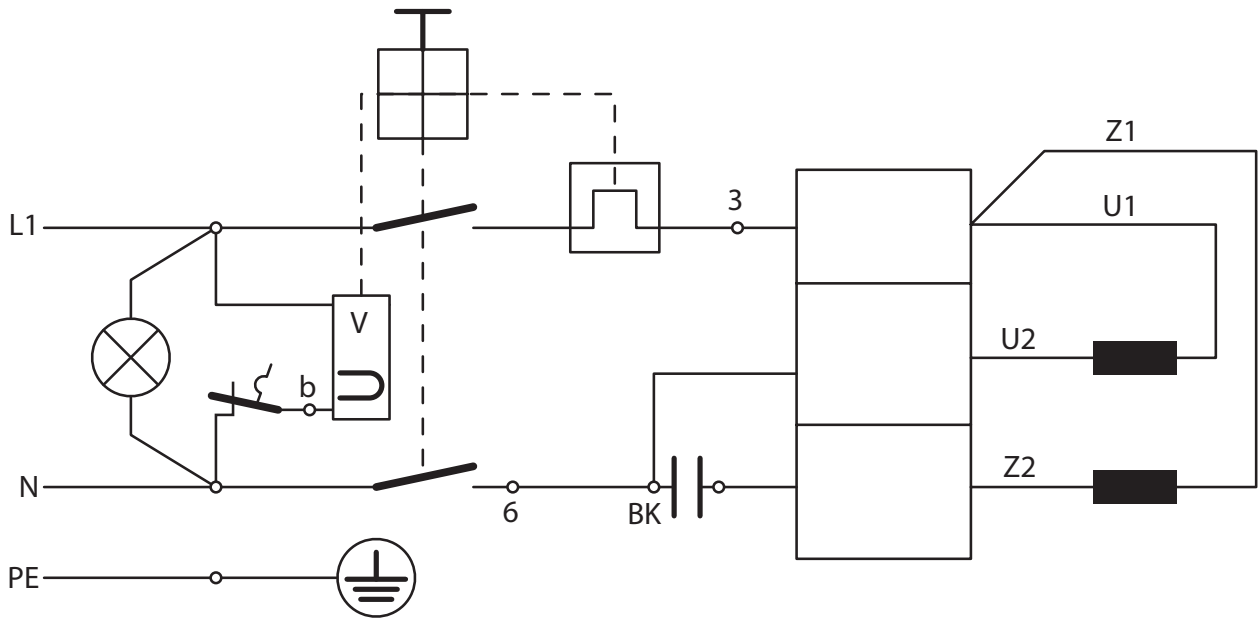

12.11 Electrical schematic HC960

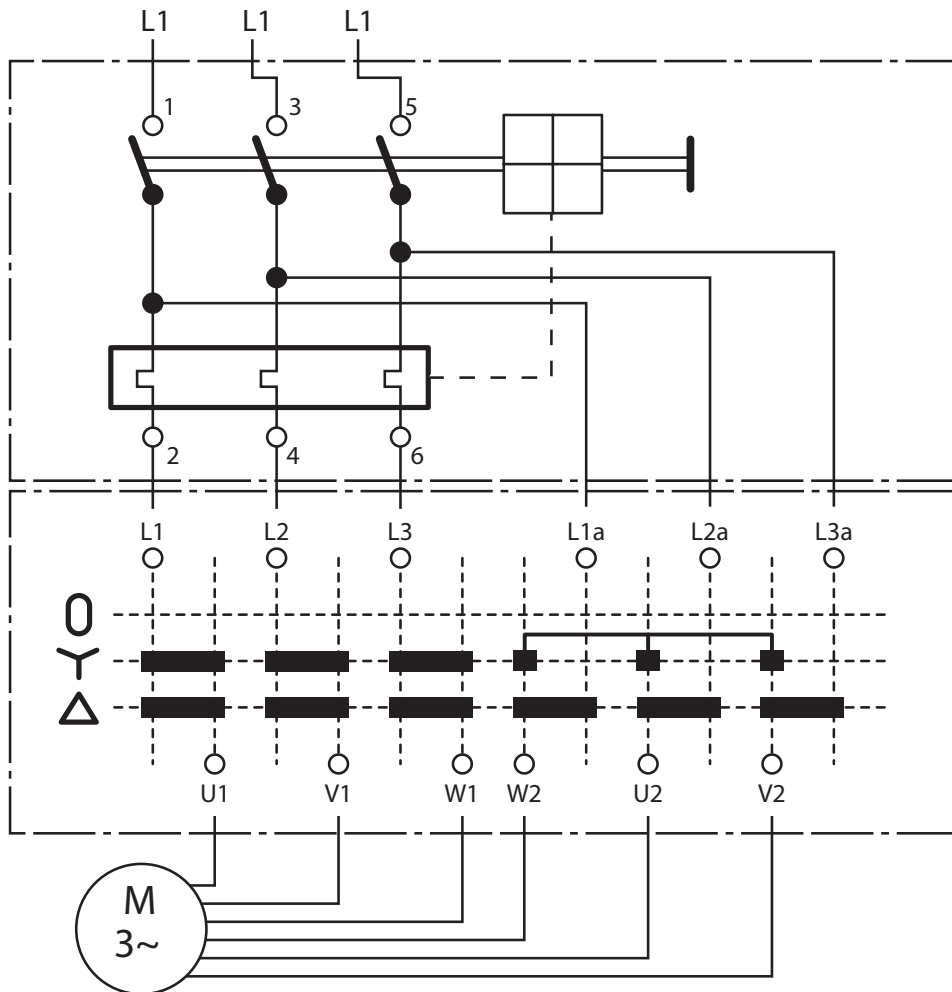



13.4 Airless tip table

WAGNER Trade Tip 2
up to 270 bar
(27 MPa)



without tip
F thread (11/16 - 16 UN)
for Wagner spray guns
Order no. **0556 042**

without tip
G thread (7/8 - 14 UN)
for Graco/Titan spray guns
Order no. **0556 041**

WAGNER tip
up to 530 bar (53 MPa)



without tip
Order no. **1088 001**

Standard tips
up to 530 bar (53 MPa)



Application	Tip marking	Spray angle	Bore inch / mm	Spraying width mm ¹⁾	Order no.	Order no.	Order no.	
Natural paints Clear paints Oils	"RED"	407	40°	0.007 / 0.18	160	0090 407	1088 407	0552 407
		507	50°	0.007 / 0.18	190	0090 507		
		209	20°	0.009 / 0.23	145	0090 209	1088 209	0552 209
		309	30°	0.009 / 0.23	160	0090 309	1088 309	0552 309
		409	40°	0.009 / 0.23	190	0090 409	1088 409	0552 409
		509	50°	0.009 / 0.23	205	0090 509	1088 509	0552 509
Synthetic-resin paints PVC paints	"RED"	609	60°	0.009 / 0.23	220	0090 609	1088 609	0552 609
		111	10°	0.011 / 0.28	85	0090 111	1088 111	0552 111
		211	20°	0.011 / 0.28	95	0090 211	1088 211	0552 211
		311	30°	0.011 / 0.28	125	0090 311	1088 311	0552 311
		411	40°	0.011 / 0.28	195	0090 411	1088 411	0552 411
		511	50°	0.011 / 0.28	215	0090 511	1088 511	0552 511
Paints, primers Zinc chromate base Fillers	"RED"	611	60°	0.011 / 0.28	265	0090 611	1088 611	0552 611
		113	10°	0.013 / 0.33	100	0090 113	1088 113	0552 113
		213	20°	0.013 / 0.33	110	0090 213	1088 213	0552 213
		313	30°	0.013 / 0.33	135	0090 313	1088 313	0552 313
		413	40°	0.013 / 0.33	200	0090 413	1088 413	0552 413
		513	50°	0.013 / 0.33	245	0090 513	1088 513	0552 513
Fillers Spray plasters Rust protection paints	"YELLOW"	613	60°	0.013 / 0.33	275	0090 613	1088 613	0552 613
		813	80°	0.013 / 0.33	305	0090 813	1088 813	0552 813
		115	10°	0.015 / 0.38	90	0090 115	1088 115	0552 115
		215	20°	0.015 / 0.38	100	0090 215	1088 215	0552 215
		315	30°	0.015 / 0.38	160	0090 315	1088 315	0552 315
		415	40°	0.015 / 0.38	200	0090 415	1088 415	0552 415
Spray plasters Rust protection paints Red lead Latex paints	"YELLOW"	515	50°	0.015 / 0.38	245	0090 515	1088 515	0552 515
		615	60°	0.015 / 0.38	265	0090 615	1088 615	0552 615
		715	70°	0.015 / 0.38	290	0090 715	1088 715	0552 715
		815	80°	0.015 / 0.38	325	0090 815	1088 815	0552 815
		217	20°	0.017 / 0.43	110	0090 217	1088 217	0552 217
		317	30°	0.017 / 0.43	150	0090 317	1088 317	0552 317
Mica paints Zinc dust paints Dispersions	"WHITE"	417	40°	0.017 / 0.43	180	0090 417	1088 417	0552 417
		517	50°	0.017 / 0.43	225	0090 517	1088 517	0552 517
		617	60°	0.017 / 0.43	280	0090 617	1088 617	0552 617
		717	70°	0.017 / 0.43	325	0090 717	1088 717	0552 717
		219	20°	0.019 / 0.48	145	0090 219	1088 219	0552 219
		319	30°	0.019 / 0.48	160	0090 319	1088 319	0552 319
Rust protection paints	"WHITE"	419	40°	0.019 / 0.48	185	0090 419	1088 419	0552 419
		519	50°	0.019 / 0.48	260	0090 519	1088 519	0552 519
		619	60°	0.019 / 0.48	295	0090 619	1088 619	0552 619
		719	70°	0.019 / 0.48	320	0090 719	1088 719	0552 719
		819	80°	0.019 / 0.48	400	0090 819	1088 819	0552 819
		221	20°	0.021 / 0.53	145	0090 221	1088 221	0552 221
Dispersion Binder, glue and filler paints	"GREEN"	421	40°	0.021 / 0.53	190	0090 421	1088 421	0552 421
		521	50°	0.021 / 0.53	245	0090 521	1088 521	0552 521
		621	60°	0.021 / 0.53	290	0090 621	1088 621	0552 621
		821	80°	0.021 / 0.53	375	0090 821	1088 821	0552 821
		223	20°	0.023 / 0.58	155	0090 223	1088 223	0552 223
		423	40°	0.023 / 0.58	180	0090 423	1088 423	0552 423
Large-area coatings	"GREEN"	523	50°	0.023 / 0.58	245	0090 523	1088 523	0552 523
		623	60°	0.023 / 0.58	275	0090 623	1088 623	0552 623
		723	70°	0.023 / 0.58	325	0090 723	1088 723	0552 723
		823	80°	0.023 / 0.58	345	0090 823	1088 823	0552 823
		225	20°	0.025 / 0.64	130	0090 225	1088 225	0552 225
		425	40°	0.025 / 0.64	190	0090 425	1088 425	0552 425
Large-area coatings	"GREEN"	525	50°	0.025 / 0.64	230	0090 525	1088 525	0552 525
		625	60°	0.025 / 0.64	250	0090 625	1088 625	0552 625
		825	80°	0.025 / 0.64	295	0090 825	1088 825	0552 825
		227	20°	0.027 / 0.69	160	0090 227	1088 227	0552 227
		427	40°	0.027 / 0.69	180	0090 427	1088 427	0552 427
		527	50°	0.027 / 0.69	200	0090 527	1088 527	0552 527
Large-area coatings	"GREEN"	627	60°	0.027 / 0.69	265	0090 627	1088 627	0552 627
		827	80°	0.027 / 0.69	340	0090 827	1088 827	0552 827
		629	60°	0.029 / 0.75	285	0090 629	1088 629	0552 629
		231	20°	0.031 / 0.79	155	0090 231	1088 231	0552 231
		431	40°	0.031 / 0.79	185	0090 431	1088 431	0552 431
		531	50°	0.031 / 0.79	220	0090 531	1088 531	0552 531
Large-area coatings	"GREEN"	631	60°	0.031 / 0.79	270	0090 631	1088 631	0552 631
		433	40°	0.033 / 0.83	220	0090 433	1088 433	0552 433
		235	20°	0.035 / 0.90	160	0090 235	1088 235	0552 235
		435	40°	0.035 / 0.90	195	0090 435	1088 435	0552 435
		535	50°	0.035 / 0.90	235	0090 535	1088 535	0552 535
		635	60°	0.035 / 0.90	295	0090 635	1088 635	0552 635
Large-area coatings	"GREEN"	839	80°	0.039 / 0.99	480	0090 839		
		243	20°	0.043 / 1.10	185	0090 243	1088 243	0552 243
		543	50°	0.043 / 1.10	340	0090 543	1088 543	0552 543
		552	50°	0.052 / 1.30	350	0090 552	1088 552	0552 552

¹⁾ Spray width at about 30 cm to the object and 100 bar (10 MPa) pressure with synthetic-resin paint 20 DIN seconds.



Deutschland	J. Wagner GmbH • Otto-Lilienthal-Straße 18 • 88677 Markdorf ☎ Tel. 0043/07544/5050 • Fax: 0043/07544/505/200 • info@wagner-group.com
Österreich	J. Wagner Ges.m.b.H • Ottogasse 2/20 • 2333 Leopoldsdorf ☎ Tel. 0043/2235/44 158 • Fax: 0043/2235/44 163 • office@wagner-group.at
Schweiz	J. Wagner AG • Industriestrasse 22 • 9450 Altstätten ☎ Tel. 0041/71/7572211 • Fax: 0041/71/7572222 • wagner@wagner-group.ch
Japan	Wagner Spraytech Japan/Ltd. • 2-35, Shinden-Nishimachi • Osaka/Japan ☎ Tel. 728/743562 • Fax: 728/744684
China	Wagner Spraytech Shanghai Co LTD • 4th Floor, No. 395 • Jianchang Xi Road Shibei Industrial Zone • Shanghai, 200436 China ☎ Tel. 0086/2166521858 • Fax: 0086/2166529819 • wagnersh@public8.sta.net.cn
France	J. Wagner France S.A.R.L. • Parc Gutenberg - Bâtiment F • 8 voie la Cardon • 91128 Palaiseau Cedex ☎ Tel. 0033/1/825011111 • Fax: 0033/1/69817257 • division.batiment@wagner-france.fr
Italia	Wagner Colora S.R.L. • Via Fermi, 3 • 20040 Burago Molgora • Milano ☎ Tel. 0039/039/625021 • Fax: 0039/039/6851800 • info@wagnercolora.com
Belgie	Wagner Spraytech • Belgium SA • Veilinglaan 58 • 1861 Meise-Wolvertem ☎ Tel. 0032/2/2694675 • Fax: 0032/2/2697845 • info@wagner-group.be
Nederland	Wagner Spraytech Benelux B.V. • Zonnebaan 10 • 3542 EC Utrecht ☎ Tel. 0031/30/2414155 • Fax: 0031/30/2411787 • info@wagner-group.nl
USA	Wagner Spraytech Corp. • P.O. Box 279 • Minneapolis, MN 55440 USA ☎ Tel. 001/763/553-7000 • Fax: 001/763/553-7288 • info@wagnersystemsinc.com
Australia	Wagner Spraytech Australia Pty. Ltd. • POB 286 • Braeside, Vic., 3195 Australia ☎ Tel. 03/95872000 • Fax: 03/95809120 • wagner@wagnerspraytech.cm.au
Great Britain	Wagner Spraytech (UK) Ltd. • The Coach House • 2 Main Road • Middleton Cheney • OX17 2ND • Great Britain ☎ 0844/335/0517 • Fax: 0044/1295/269861 • enquiry@wagnerspraytech.co.uk
España	Wagner Spraytech Ibérica S.A. • P.O. Box 132, Crta. N-340 • KM 1.245,4 • 08750 Molins de Rey - Barcelona Spain ☎ Tel. 0034/93/6800028 • Fax: 0034/93/6800555 • info@wagnerspain.com
Danmark	Wagner Spraytech Scandinavia A/S • Helgeshøj Allé 28 • DK2605 Taastrup • Denmark ☎ Tel. 0045/43/271818 • Fax: 0045/43/430528 • wagner@wagner-group.dk
Sverige	Wagner Spraytech Scandinavia A/S • Helgeshøj Allé 28 • DK2605 Taastrup • Denmark ☎ Tel. 0046/42/150020 • Fax: 0046/42/150020 • mailbox@wagner.se



Important notes on product liability

As a result of an EC regulation being effective as from January 1, 1990, the manufacturer shall only be liable for his product if all parts come from him or are released by him, and if the devices are properly mounted and operated.

If the user applies outside accessories and spare parts, the manufacturer's liability can fully or partially be inapplicable; in extreme cases usage of the entire device can be prohibited by the competent authorities (employer's liability insurance association and factory inspectorate division).

Only the usage of original WAGNER accessories and spare parts guarantees that all safety regulations are observed.

3+2 years guarantee for professional finishing

Wagner professional guarantee

(Status 01.02.2009)

1. Scope of guarantee

All Wagner professional colour application devices (hereafter referred to as products) are carefully inspected, tested and are subject to strict checks under Wagner quality assurance. Wagner exclusively issues extended guarantees to commercial or professional users (hereafter referred to as "customer") who have purchased the product in an authorised specialist shop, and which relate to the products listed for that customer on the Internet under www.wagner-group.com/profi-guarantee.

The buyer's claim for liability for defects from the purchase agreement with the seller as well as statutory rights are not impaired by this guarantee.

We provide a guarantee in that we decide whether to replace or repair the product or individual parts, or take the device back and reimburse the purchase price. The costs for materials and working hours are our responsibility. Replaced products or parts become our property.

2. Guarantee period and registration

The guarantee period amounts to 36 months. For industrial use or equal wear, such as shift operations in particular, or in the event of rentals it amounts to 12 months.

Systems driven by petrol or air are also guaranteed for a 12 month period.

The guarantee period begins with the day of delivery by the authorised specialist shop. The date on the original purchase document is authoritative.

For all products bought in authorised specialist shops from 01.02.2009 the guarantee period is extended to 24 months providing the buyer of these devices registers in accordance with the following conditions within 4 weeks of the day of delivery by the authorised specialist shop.

Registration can be completed on the Internet under www.wagner-group.com/profi-guarantee. The guarantee certificate is valid as confirmation, as is the original purchase document that carries the date of the purchase. Registration is only possible if the buyer is in agreement with having the data being stored that is entered during registration.

When services are carried out under guarantee the guarantee period for the product is neither extended nor renewed.

Once the guarantee period has expired, claims made against the guarantee or from the guarantee can no longer be enforced.

3. Handling

If defects can be seen in the materials, processing or performance of the device during the guarantee period, guarantee claims must be made immediately, or at the latest within a period of 2 weeks.

The authorised specialist shop that delivered the device is entitled to accept guarantee claims. Guarantee claims may also be made to the service centres named in our operating instructions. The product has to be sent without charge or presented together with the original purchase document that includes details of the purchase date and the name of the product. In order to claim for an extension to the guarantee, the guarantee certificate must be included.

The costs as well as the risk of loss or damage to the product in transit or by the centre that accepts the guarantee claims or who delivers the repaired product, are the responsibility of the customer.

4. Exclusion of guarantee

Guarantee claims cannot be considered

- for parts that are subject to wear and tear due to use or other natural wear and tear, as well as defects in the product that are a result of natural wear and tear, or wear and tear due to use. This includes in particular cables, valves, packaging, jets, cylinders, pistons, means-carrying housing components, filters, pipes, seals, rotors, stators, etc. Damage due to wear and tear that is caused in particular by sanded coating materials, such as dispersions, plaster, putty, adhesives, glazes, quartz foundation.
- in the event of errors in devices that are due to non-compliance with the operating instructions, unsuitable or unprofessional use, incorrect assembly and/or commissioning by the buyer or by a third party, or utilisation other than is intended, abnormal ambient conditions, unsuitable coating materials, unsuitable operating conditions, operation with the incorrect mains voltage supply/frequency, over-operation or defective servicing or care and/or cleaning.
- for errors in the device that have been caused by using accessory parts, additional components or spare parts that are not original Wagner parts.
- for products to which modifications or additions have been carried out.
- for products where the serial number has been removed or is illegible
- for products to which attempts at repairs have been carried out by unauthorised persons.
- for products with slight deviations from the target properties, which are negligible with regard to the value and usability of the device.
- for products that have been partially or fully taken apart.

5. Additional regulations.

The above guarantees apply exclusively to products that have been bought by authorised specialist shops in the EU, CIS, Australia and are used within the reference country.

If the check shows that the case is not a guarantee case, repairs are carried out at the expense of the buyer.

The above regulations manage the legal relationship to us conclusively. Additional claims, in particular for damages and losses of any type, which occur as a result of the product or its use, are excluded from the product liability act except with regard to the area of application.

Claims for liability for defects to the specialist trader remain unaffected.

German law applies to this guarantee. The contractual language is German. In the event that the meaning of the German and a foreign text of this guarantee deviate from one another, the meaning of the German text has priority.

J. Wagner GmbH
Division Professional Finishing
Otto Lilienthal Strasse 18
88677 Markdorf
Federal Republic of Germany

D**Entsorgungshinweis:**

Gemäß der europäischen Richtlinie 2002/96/EG zur Entsorgung von Elektro-Altgeräten, und deren Umsetzung in nationales Recht, ist dieses Produkt nicht über den Hausmüll zu entsorgen, sondern muss der umweltgerechten Wiederverwertung zugeführt werden!

Ihr Wagner-Altgerät wird von uns, bzw. unseren Handelsvertretungen zurückgenommen und für Sie umweltgerecht entsorgt. Wenden Sie sich in diesem Fall an einen unserer Service-Stützpunkte, bzw. Handelsvertretungen oder direkt an uns.

**F****Consignes d'élimination:**

Selon la directive européenne 2002/96/CE sur l'élimination des vieux appareils électriques et sa conversion en droit national, ce produit ne peut pas être jeté dans les ordures ménagères, mais est à amener à un point de recyclage en vue d'une élimination dans le respect de l'environnement!

Wagner, resp. nos représentations commerciales reprennent votre vieil appareil Wagner pour l'éliminer dans le respect de l'environnement. Adressez-vous donc directement à nos points de service resp. représentations commerciales ou directement à nous.

**GB****Note on disposal:**

In observance of the European Directive 2002/96/EC on waste electrical and electronic equipment and implementation in accordance with national law, this product is not to be disposed of together with household waste material but must be recycled in an environmentally friendly way!

Wagner or one of our dealers will take back your used Wagner waste electrical or electronic equipment and will dispose of it for you in an environmentally friendly way. Please ask your local Wagner service centre or dealer for details or contact us direct.

**I****Indicazione per lo smaltimento:**

Secondo la direttiva europea 2002/96/CE per lo smaltimento di vecchi apparecchi elettrici e la sua conversione nel diritto nazionale, questo prodotto non va smaltito attraverso i rifiuti domestici, bensì va smaltito portandolo al riutilizzo in conformità della tutela ambiente!

Il Vs. apparecchio vecchio Wagner verrà preso indietro da noi resp. dalle nostre rappresentanze commerciali e smaltito per Voi in conformità della tutela ambiente. In questo caso rivolgetevi ad uno dei nostri punti di servizio per l'assistenza clienti, resp. ad una delle nostre rappresentanze commerciali oppure direttamente a noi.



(D)

CE Konformitätserklärung

Hiermit erklären wir, dass die Bauart von
WAGNER HC 920, HC 940, HC 960
folgenden einschlägigen Bestimmungen entspricht:
98/37 EG.

Angewendete harmonisierte Normen, insbesondere:
EN 292-1/-2, EN 55014-1/2 (Geräte mit Elektromotor),
EN 60204 (Geräte mit Elektromotor).

Angewendete nationale technische Spezifikationen, insbesondere:
VBG 5, BGV D15

Datum: 03.17.2006

(GB)

CE Declaration of conformity

Herewith we declare that the supplied version of
WAGNER HC 920, HC 940, HC 960
Complies with the following provisions applying to it:
98/37 EG.

Applied harmonized standards, in particular:
EN 292-1/-2, EN 55014-1/2 (groupes avec moteur électrique),
EN 60204 (groupes avec moteur électrique).

Applied national technical standards and specifications, in particular:
VBG 5, BGV D15

Date: 03.17.2006

(F)

CE Déclaration de conformité

Par la présente, nous déclarons, que le type de
WAGNER HC 920, HC 940, HC 960
Correspond aux dispositions pertinentes suivantes:
98/37 EG.

Normes harmonisée utilisées, notamment:
EN 292-1/-2, EN 55014-1/2 (electric units),
EN 60204 (electric units).

Normes et spécifications techniques nationales qui ont été utilisées, notamment:
VBG 5, BGV D15

Date: 03.17.2006

(I)

CE Dichiarazione di conformità

Si dichiara che il modello della
WAGNER HC 920, HC 940, HC 960
è conforme alle seguenti disposizioni pertinenti:
98/37 EG.

Norme armonizzate applicate, in particolare:
EN 292-1/-2, EN 55014-1/2 (apparecchi con motore elettrico),
EN 60204 (apparecchi con motore elettrico).

Norme e specificazioni tecniche nazionali applicate in particolare:
VBG 5, BGV D15

Data: 03.17.2006



Geschäftsführer
Executive Officer
Directeur
Dirigente affaristico



Unterschrift
Signature
Signature
Firma

Entwicklungsleiter
Head of Development
Directeur du développement
Dirigente tecnico

Free Manuals Download Website

<http://myh66.com>

<http://usermanuals.us>

<http://www.somanuals.com>

<http://www.4manuals.cc>

<http://www.manual-lib.com>

<http://www.404manual.com>

<http://www.luxmanual.com>

<http://aubethermostatmanual.com>

Golf course search by state

<http://golfingnear.com>

Email search by domain

<http://emailbydomain.com>

Auto manuals search

<http://auto.somanuals.com>

TV manuals search

<http://tv.somanuals.com>