

D GB F I

WAGNER®

Betriebsanleitung

Operating manualp. 24

Mode d'emploi.....p. 48

Istruzioni per l'uso.....p. 72

HC950 • HC950 SSP

HC970 • HC970 SSP

Airless Hochdruck-Spritzgerät

Airless high-pressure spraying unit

Groupe de projection à haute pression

Impianto per la verniciatura a spruzzo ad alta pressione Airless

HC 950 230V

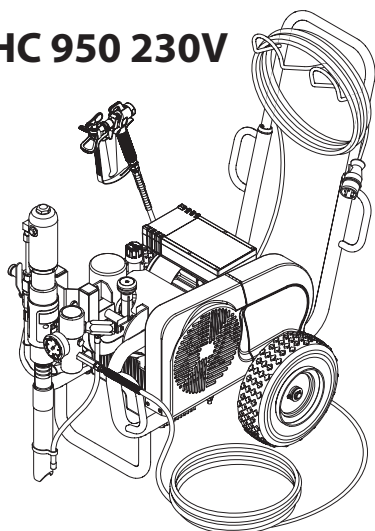

HC 970 400V

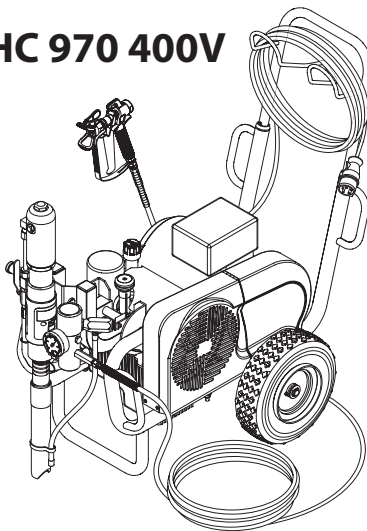

**HC 950
HC 970**

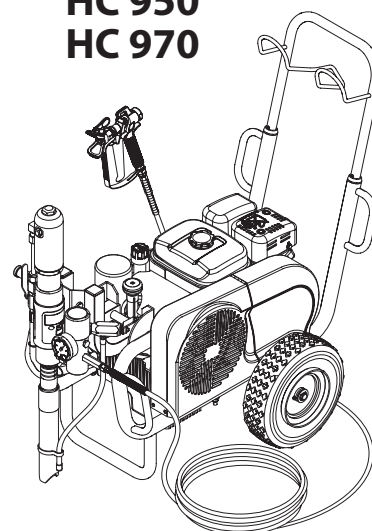

**HC 950 SSP
230V**

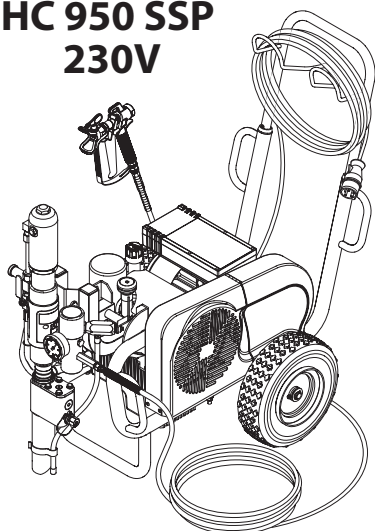

**HC 970 SSP
400V**

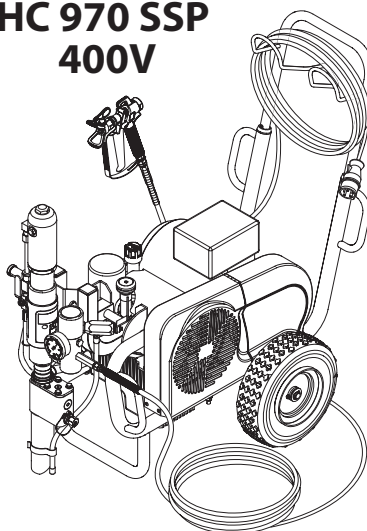

**HC 950 SSP
HC 970 SSP**

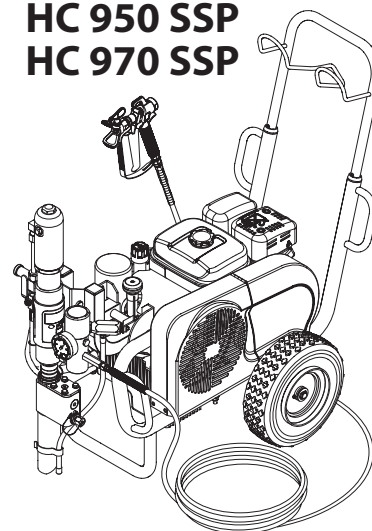

Warning!

Attention: Danger of injury by injection!
Airless units develop extremely high spraying pressures.



1

Never put your fingers, hands or any other parts of the body into the spray jet!

Never point the spray gun at yourself, other persons or animals.

Never use the spray gun without safety guard.

Do not treat a spraying injury as a harmless cut. In case of injury to the skin through coating materials or solvents, consult a doctor immediately for quick and expert treatment. Inform the doctor about the coating material or solvent used.

2

The operating instructions state that the following points must always be observed before starting up:

1. Faulty units must not be used.
2. Secure WAGNER spray gun using the safety catch on the trigger.
3. Ensure that the unit is properly earthed.
4. Check allowable operating pressure of high-pressure hose and spray gun.
5. Check all connections for leaks.

3

The instructions regarding regular cleaning and maintenance of the unit must be strictly observed.

Before any work is done on the unit or for every break in work the following rules must be observed:

1. Release the pressure from spray gun and hose.
2. Secure the WAGNER spray gun using the safety catch on the trigger.
3. Switch off unit.

Be safety conscious!







Contents

	Page		Page
1. Safety regulations for Airless spraying	26	9. Remedy in case of faults	40
1.1 Explanation of symbols used	26	9.1 Gasoline engine	40
1.2 Electrical safety.....	27	9.2 Electric motor	40
1.3 Gasoline engine safety	28	9.3 Hydraulic motor.....	40
1.4 Setting up on uneven surfaces.....	28	9.4 Material feed pump.....	41
2. General view of application	29	10. Servicing	42
2.1 Application	29	10.1 General servicing.....	42
2.2 Coating materials	29	10.2 Checking the oil level in the hydraulic oil tank	42
3. Description of unit	29	10.3 Oil and oil filter change of the hydraulic oil pump	42
3.1 Airless process.....	29	10.4 High-pressure hose.....	42
3.2 Functioning of the unit	29	11. Appendix	43
3.3 Illustration legend for gasoline HC units	30	11.1 Selection of tip	43
3.4 Illustration of gasoline HC units.....	30	11.2 Servicing and cleaning of Airless hard-metal tips	43
3.5 Illustration legend for electric HC units.....	31	11.3 Spray gun accessories.....	43
3.6 Illustration of electric HC units	31	11.4 Airless tip table.....	44/45
3.7 Technical data for gasoline HC units.....	32	11.5 2Speed Tip table.....	46
3.8 Technical data for electric HC units	33	Sales and service companies	47
3.9 Transport.....	34	Accessories and spare parts	96
3.10 Transport in vehicle.....	34	Accessories for HC units I	96/97
3.11 Crane transport.....	34	Accessories for HC units II	98/99
4. Starting operation	35	Spare parts list for the main assembly.....	100/101
4.1 Changing the material feed pump position.....	35	Spare parts list for the cart assembly	102/103
4.2 High-pressure hose, spray gun and separating oil	36	Spare parts list for the hydraulic system.....	104/105
4.3 Gasoline engine (gas units only).....	36	Spare parts list for the hydraulic motor	106/107
4.4 Connection to the mains (electric units only).....	36	Spare parts list for the fluid section	108/109
4.5 Flushing preserving fluid during initial start-up	36	Spare parts list for the shovel valve	
4.6 Taking the unit into operation with coating material.....	37	HC 950-SSP • HC 970-SSP.....	110/111
5. Spraying technique	37	Spare parts list for the high-pressure filter	112/113
6. Handling the high-pressure hose	37	Spare parts list for electric convertokit (230V / 400V).....	114
7. Interruption of work	37	Spare parts list for gas convertokit	116
8. Cleaning the unit (shutting down)	38	Spare parts list for belt guard assembly.....	117
8.1 Cleaning the unit from the outside	38	Spare parts list for bleed valve	118
8.2 Cleaning the high-pressure filter.....	38	Electrical schematic HC950 • HC970	119
8.3 Cleaning Airless spray gun.....	39	Important notes on product liability	121
		3+2 years guarantee for professional finishing	121

1. Safety regulations for Airless spraying

1.1 Explanation of symbols used

This manual contains information that must be read and understood before using the equipment. When you come to an area that has one of the following symbols, pay particular attention and make certain to heed the safeguard.

	This symbol indicates a potential hazard that may cause serious injury or loss of life. Important safety information will follow.
	This symbol indicates a potential hazard to you or to the equipment. Important information that tells how to prevent damage to the equipment or how to avoid causes of minor injuries will follow.
	Danger of skin injection
	Danger of fire from solvent and paint fumes
	Danger of explosion from solvent, paint fumes and incompatible materials
	Danger of injury from inhalation of harmful vapors
	Notes give important information which should be given special attention.



HAZARD: INJECTION INJURY

A high pressure stream produced by this equipment can pierce the skin and underlying tissues, leading to serious injury and possible amputation.

Do not treat a spraying injury as a harmless cut. In case of injury to the skin through coating materials or solvents, consult a doctor immediately for quick and expert treatment. Inform the doctor about the coating material or solvent used.

PREVENTION:

- NEVER aim the gun at any part of the body.
- NEVER allow any part of the body to touch the fluid stream. DO NOT allow body to touch a leak in the fluid hose.
- NEVER put your hand in front of the gun. Gloves will not provide protection against an injection injury.
- ALWAYS lock the gun trigger, shut the fluid pump off and release all pressure before servicing, cleaning the tip guard, changing tips, or leaving unattended. Pressure will not be released by turning off the engine. The PRIME/SPRAY valve or pressure bleed valve must be turned to their appropriate positions to relieve system pressure.
- ALWAYS keep tip guard in place while spraying. The tip guard provides some protection but is mainly a warning device.
- ALWAYS remove the spray tip before flushing or cleaning the system.
- NEVER use a spray gun without a working trigger lock and trigger guard in place.

- All accessories must be rated at or above the maximum operating pressure range of the sprayer. This includes spray tips, guns, extensions, and hose.



HAZARD: HIGH PRESSURE HOSE

The paint hose can develop leaks from wear, kinking and abuse. A leak can inject material into the skin. Inspect the hose before each use.

PREVENTION:

- High-pressure hoses must be checked thoroughly before they are used.
- Replace any damaged high-pressure hose immediately.
- Never repair defective high-pressure hoses yourself!
- Avoid sharp bends and folds: the smallest bending radius is about 20 cm.
- Do not drive over the high-pressure hose. Protect against sharp objects and edges.
- Never pull on the high-pressure hose to move the device.
- Do not twist the high-pressure hose.
- Do not put the high-pressure hose into solvents. Use only a wet cloth to wipe down the outside of the hose.
- Lay the high-pressure hose in such a way as to ensure that it cannot be tripped over.



Only use WAGNER original-high-pressure hoses in order to ensure functionality, safety and durability.



HAZARD: EXPLOSION OR FIRE

Solvent and paint fumes can explode or ignite. Severe injury and/or property damage can occur.

PREVENTION:

- Do not use materials with a flashpoint below 21° C (70° F). Flashpoint is the temperature at which a fluid can produce enough vapors to ignite.
- Do not use the unit in work places which are covered by the explosion protection regulations.
- Provide extensive exhaust and fresh air introduction to keep the air within the spray area free from accumulation of flammable vapors.
- Avoid all ignition sources such as static electricity sparks, electrical appliances, flames, pilot lights, hot objects, and sparks from connecting and disconnecting power cords or working light switches.
- Do not smoke in spray area.
- Place sprayer sufficient distance from the spray object in a well ventilated area (add more hose if necessary). Flammable vapors are often heavier than air. Floor area must be extremely well ventilated. The pump contains arcing parts that emit sparks and can ignite vapors.
- The equipment and objects in and around the spray area must be properly grounded to prevent static sparks.
- Use only conductive or earthed high pressure fluid hose. Gun must be earthed through hose connections.
- Power cord must be connected to a grounded circuit (electric units only).
- Always flush unit into separate metal container, at low pump pressure, with spray tip removed. Hold gun firmly against side of container to ground container and prevent static sparks.

- Follow material and solvent manufacturer's warnings and instructions. Be familiar with the coating material's MSDS sheet and technical information to ensure safe use.
- Use lowest possible pressure to flush equipment.
- When cleaning the unit with solvents, the solvent should never be sprayed or pumped back into a container with a small opening (bunghole). An explosive gas/air mixture can arise. The container must be earthed.



HAZARD: HAZARDOUS VAPORS

Paints, solvents, and other materials can be harmful if inhaled or come in contact with body. Vapors can cause severe nausea, fainting, or poisoning.

PREVENTION:

- Wear respiratory protection when spraying. Read all instructions supplied with the mask to be sure it will provide the necessary protection.
- All local regulations regarding protection against hazardous vapors must be observed.
- Wear protective eyewear.
- Protective clothing, gloves and possibly skin protection cream are necessary for the protection of the skin. Observe the regulations of the manufacturer concerning coating materials, solvents and cleaning agents in preparation, processing and cleaning units.



HAZARD: GENERAL

This product can cause severe injury or property damage.

PREVENTION:

- Follow all appropriate local, state, and national codes governing ventilation, fire prevention, and operation.
- Pulling the trigger causes a recoil force to the hand that is holding the spray gun. The recoil force of the spray gun is particularly powerful when the tip has been removed and a high pressure has been set on the airless pump. When cleaning without a spray tip, set the pressure control knob to the lowest pressure.
- Use only manufacturer authorized parts. User assumes all risks and liabilities when using parts that do not meet the minimum specifications and safety devices of the pump manufacturer.
- ALWAYS follow the material manufacturer's instructions for safe handling of paint and solvents.
- Clean up all material and solvent spills immediately to prevent slip hazard.
- Wear ear protection. This unit can produce noise levels above 85 dB(A).
- Never leave this equipment unattended. Keep away from children or anyone not familiar with the operation of airless equipment.
- Do not spray on windy days.
- The device and all related liquids (i.e. hydraulic oil) must be disposed of in an environmentally friendly way.

1.2 Electric Safety

Electric models must be earthed. In the event of an electrical short circuit, earthing reduces the risk of electric shock by providing an escape wire for the electric current. This product is equipped with a cord having an earthing wire with an appropriate earthing plug. Connection to the mains only through a special feed point, e.g. through an error protection installation with INF < 30 mA.



DANGER — Work or repairs at the electrical equipment may only be carried out by a skilled electrician. No liability is assumed for incorrect installation. Switch the unit off. Before all repair work, unplug the power plug from the outlet.

Danger of short-circuits caused by water ingressing into the electrical equipment. Never spray down the unit with high-pressure or high-pressure steam cleaners.

Work or repairs at the electrical equipment:

These may only be carried out by a skilled electrician. No liability is assumed for incorrect installation.

1.3 Gasoline Engine Safety



Always place sprayer outside of structure in fresh air. Keep all solvents away from engine exhaust. Never fill fuel tank with a running or hot engine. Hot surface can ignite spilled fuel. Always attach ground wire from pump to a grounded object. Refer to engine owner's manual for complete safety information.

1. Gas engines are designed to give safe and dependable service if operated according to instructions. Read and understand the engine manufacturer's Owner's Manual before operating the engine. Failure to do so could result in personal injury or equipment damage.
2. To prevent fire hazards and to provide adequate ventilation, keep the engine at least 1 meter (3 feet) away from buildings and other equipment during operation. Do not place flammable objects close to the engine.
3. People who are not operating the device must stay away from the area of operation due to a possibility of burns from hot engine components or injury from any equipment the engine may be used to operate.
4. Know how to stop the engine quickly, and understand the operation of all controls. Never permit anyone to operate the engine without proper instructions.
5. Gasoline is extremely flammable and is explosive under certain conditions.
6. Refuel in a well-ventilated area with the engine stopped. Do not smoke or allow flames or sparks in the refueling area or where gasoline is stored.
7. Do not overfill the fuel tank. After refueling, make sure the tank cap is closed properly and securely.
8. Be careful not to spill fuel when refueling. Fuel vapor or spilled fuel may ignite. If any fuel is spilled, make sure the area is dry before starting the engine.
9. Never run the engine in an enclosed or confined area. Exhaust contains poisonous carbon monoxide gas; exposure may cause loss of consciousness and may lead to death.
10. The muffler becomes very hot during operation and remains hot for a while after stopping the engine. Be careful not to touch the muffler while it is hot. To avoid severe burns or fire hazards, let the engine cool before transporting it or storing it indoors.
11. Never ship/transport sprayer with gasoline in the tank.



DO NOT use this equipment to spray water or acid.

1.4 Setting up on uneven surfaces

The front side of the unit must point downwards to prevent sliding away.

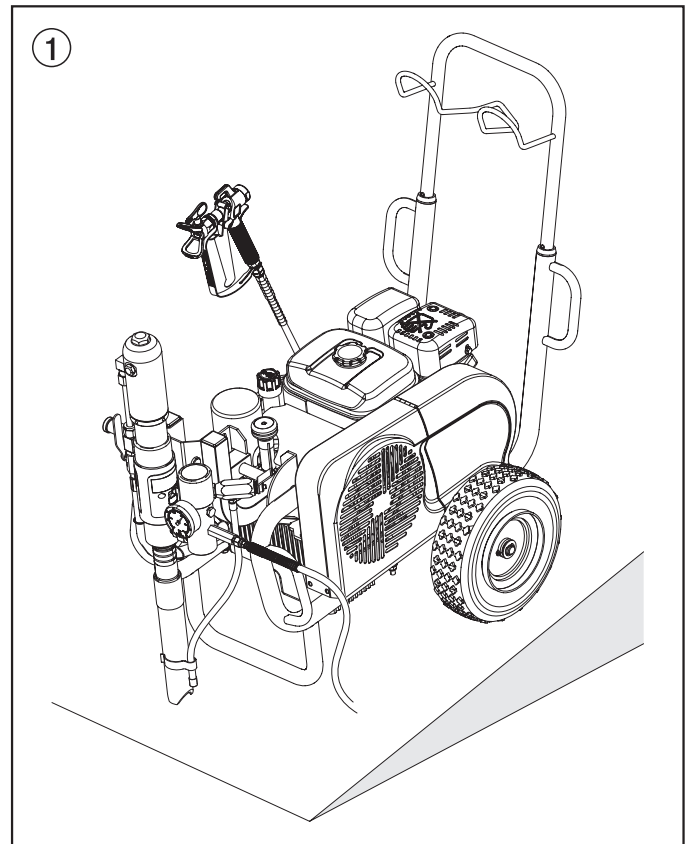

2. General view of application

2.1 Application

Priming and final coating of large areas, sealing, impregnation, construction sanitation, façade protection and renovation, rust protection and building protection, roof coating, roof sealing, concrete sanitation, as well as heavy corrosion protection.

Examples of objects to be sprayed

Large-scale construction sites, underground construction, cooling towers, bridges, sewage treatment plants and terraces.

2.2 Coating materials

Processible coating materials



Pay attention to the Airless quality of the coating materials to be processed.

Latex paint, dispersion paints, fire protection and thick film materials, zinc dust and micaceous iron ore paints, Airless spray primer, sprayable glue, anti-corrosive agents, thick coating materials and bitumen-like coating materials.

No other materials should be used for spraying without WAGNER's approval.

HC 950-SSP

With suitable accessories, especially for working with airless spray primer (Object size: 200-800 m²).

HC 970-SSP

Especially suited to working with airless spray primer (Object size: more than 800 m²).

Filtering

In spite of the high-pressure filter, filtering of the coating material is to be recommended in general (except when processing airless joint filler).

Stir coating material before commencement of work.



Make sure when stirring with motor-driven agitators that no air bubbles are stirred in. Air bubbles disturb when spraying and can, in fact, lead to interruption of operation.

Viscosity

It is possible to work with high-viscosity coating materials with the devices.

If highly viscous coating materials cannot be sucked up, they must be diluted in accordance with the manufacturer's instruction.

Two-component coating material

The appropriate processing time must be adhered to exactly. Within this time rinse through and clean the unit meticulously with the appropriate cleaning agents.

Coating materials with sharp-edged additional materials

These have a strong wear and tear effect on valves, high-pressure hose, spray gun and tip. The durability of these parts can be reduced appreciably through this.

3. Description of unit

3.1 Airless process

The main area of application are thick layers of highly viscous coating material for large areas and a high consumption of material.

A piston pump takes in the coating material by suction and conveys it to the tip. Pressed through the tip at a pressure of up to a maximum of 250 bar (25 MPa), the coating material is atomised. This high pressure has the effect of micro fine atomisation of the coating material.

As no air is used in this process, it is described as an AIRLESS process.

This method of spraying has the advantages of finest atomisation, cloudless operation and a smooth, bubble-free surface. As well as these, the advantages of the speed of work and convenience must be mentioned.

3.2 Functioning of the unit

The following section contains a brief description of the technical construction for better understanding of the function.

WAGNER HC 950 • 970 are high-pressure spraying units driven by either a gasoline engine or electric motor.

The gasoline engine or electric motor (fig. 2, item 1) drives the hydraulic pump (3) by means of a V-belt which is under the belt cover (2). Hydraulic oil flows to the hydraulic motor (4) and then moves the piston up and down in the material feed pump (5).

With devices HC 950-SSP and HC 970-SSP, the piston in the material feed pump moves a shovel valve (6). The shovel valve feeds high-viscosity coating materials.

The inlet valve is opened automatically by the upwards movement of the piston. The outlet valve is opened when the piston moves downward.

The coating material flows under high pressure through the high-pressure hose to the spray gun. When the coating material exits from the tip it atomises.

The pressure control valve (7) controls the volume and the operating pressure of the coating material.

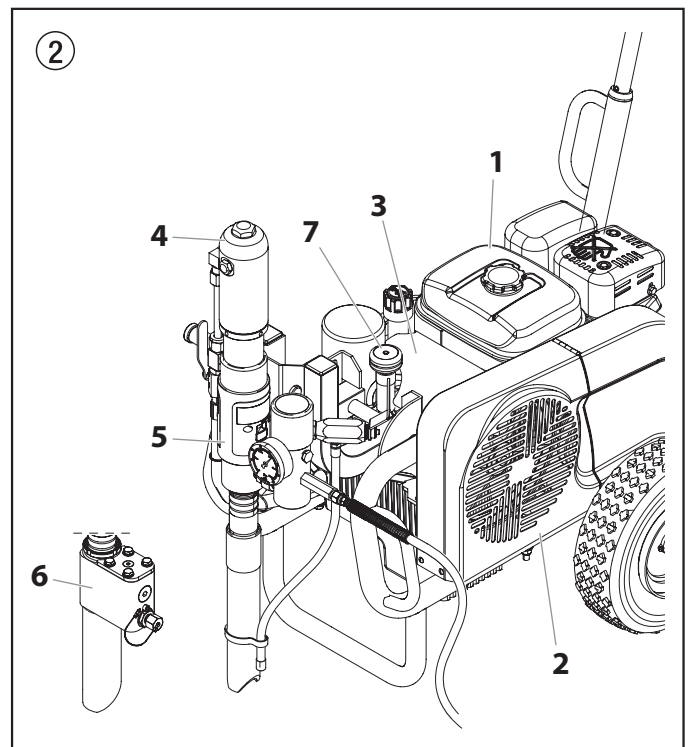

3.3 Illustration legend for gasoline HC units

- | | |
|--|--|
| 1 Spray gun | 12 Oil cup for separating oil (separating oil prevents increased wear and tear of the packings) |
| 2 High-pressure hose | 13 Ball valve: horizontal position – hydraulic motor switched off
vertical position – hydraulic motor switched on |
| 3 Gasoline engine | 14 Handle for swiveling the material feed pump |
| 4 Extractable handle | 15 Hydraulic motor |
| 5 V-belt under the belt cover | 16 Relief valve handle: Turn left for circulation ↻
Turn right for spray ➤ |
| 6 Return hose | 17 Hydraulic oil pump |
| 7 Suction tube | 18 Pressure control knob |
| 8 High-pressure filter | 19 Oil measuring stick |
| 9 Material feed pump — HC 950, HC 970 | |
| 10 Material feed pump — HC 950-SSP, HC 970-SSP | |
| 11 Pressure gauge | |

3.4 Illustration of gasoline HC units

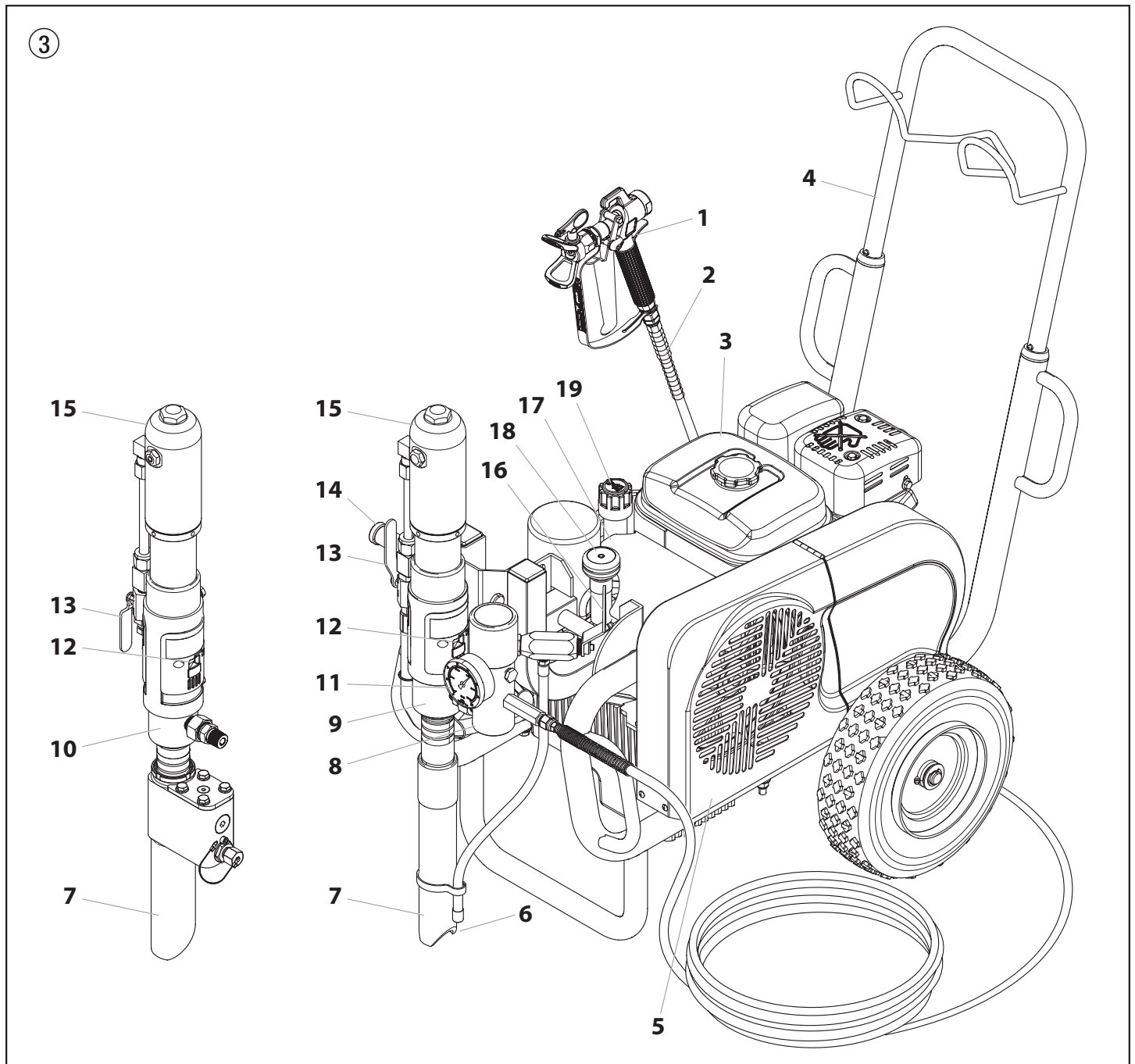

3.5 Illustration legend for electric HC units

- | | |
|---|--|
| 1 Spray gun | 12 Suction tube |
| 2 High-pressure hose | 13 High-pressure filter |
| 3 Electric motor | 14 Material feed pump — HC 950, HC 970 |
| 4 ON/OFF switch — HC 950, HC 950-SSP | 15 Material feed pump — HC 950-SSP, HC 970-SSP |
| 5 Control lamp that shows unit operational — HC 950, HC 950-SSP | 16 Pressure gauge |
| 6 Power cord | 17 Oil cup for separating oil (separating oil prevents increased wear and tear of the packings) |
| 7 Extractable handle | 18 Ball valve: horizontal position – hydraulic motor switched off
vertical position – hydraulic motor switched on |
| 8 Control lamp that shows unit operational — HC 970, HC 970-SSP | 19 Handle for swiveling the material feed pump |
| 9 ON/OFF switch (400 V) — HC 970, HC 970-SSP | 20 Hydraulic motor |
| 10 V-belt under the belt cover | 21 Relief valve handle: Turn left for circulation ↻
Turn right for spray ➤ |
| 11 Return hose | 22 Hydraulic oil pump |
| | 23 Pressure control knob |
| | 24 Oil measuring stick |

3.6 Illustration of electric HC units

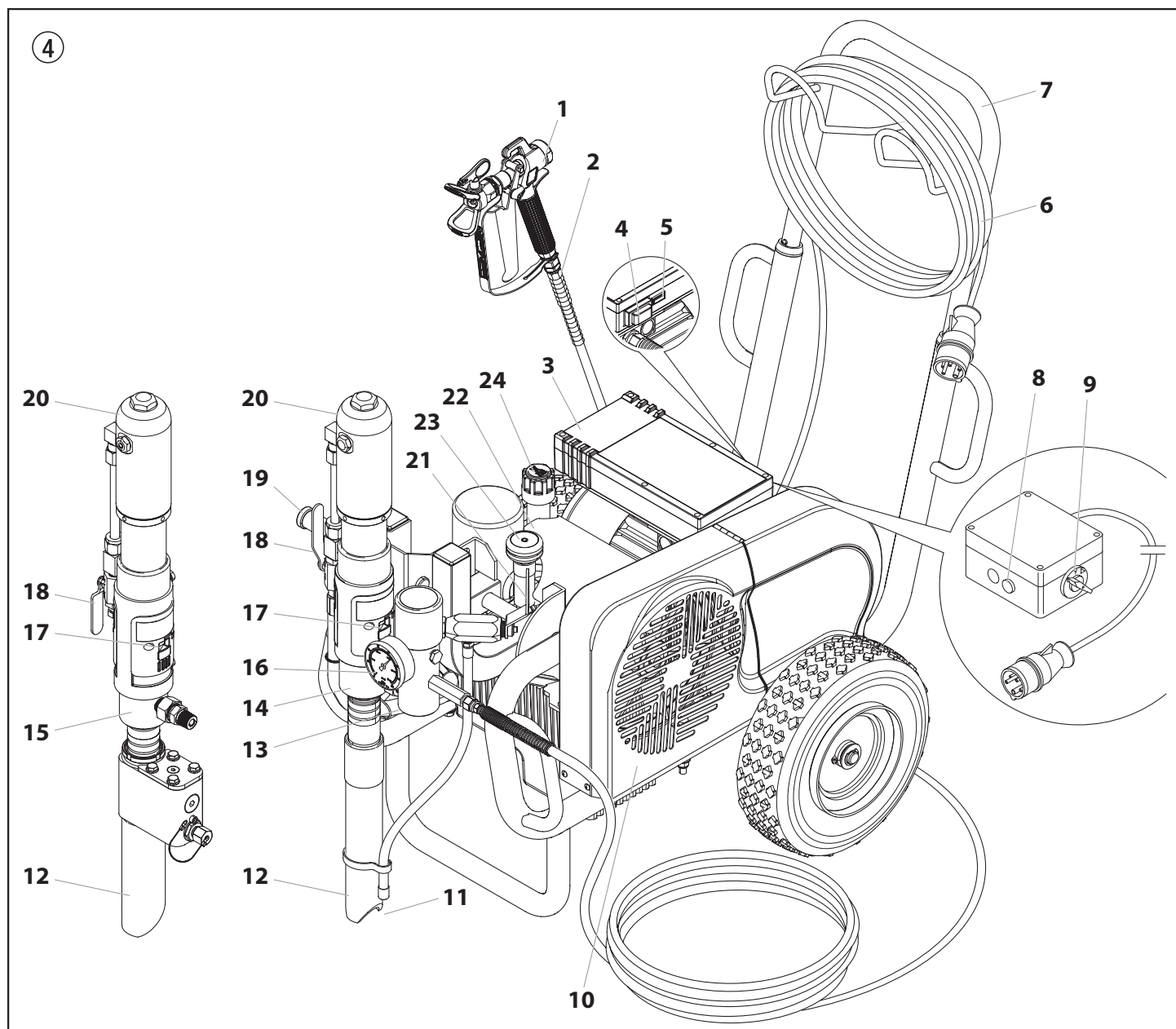

3.7 Technical data for gasoline HC units

	HC 950 (0528500)	HC 950-SSP (0528502)	HC 970 (0528508)	HC 970-SSP (0528506)
Gasoline engine, power				
4.1 kW:	*	*		
6 kW:			*	*
Max. operating pressure				
25 MPa (250 bar):	*	*	*	*
Max. volume flow				
8 l/min:	*	*		
12 l/min:			*	*
Volume flow at 12 MPa (120) bar				
7.6 l/min:	*	*		
11 l/min:			*	*
Max. size of tip with a spray gun				
0.052 inch – 1.30 mm:	*	*		
0.056 inch – 1.42 mm:			*	*
Fluid outlet fitting				
3/8 inch – 9.5 mm:	*			
1/2 inch – 12.7 mm:		*	*	*
Max. temperature of the coating material				
43° C:	*	*	*	*
Max. Viscosity				
50.000 mPa-s:	*	*		
65.000 mPa-s:			*	*
Filter insert (standard equipment)				
0 Mesh:	*	*	*	*
Weight				
76 kg	*	*		
88 kg			*	*
Hydraulic oil filling quantity				
4.7 l ISO 32:	*	*	*	*
Max. tire pressure				
0.2 MPa (2 bar):	*	*	*	*
Special high-pressure hose				
DN 10 mm, 15 m, connection thread NPSM 3/8:	*			
DN 13 mm, 15 m, connection thread NPSM 1/2:		*	*	*
Hose whip				
DN 10 mm, 2.5 m, connection thread NPSM 3/8:		*	*	*
Dimensions L x W x H				
1185 x 955 x 655 mm:	*	*		
1200 x 955 x 655 mm:			*	*
Max.sound pressure level:				
92 dB (A)*	*	*		
98 dB (A)*			*	*

* Place of measurement: 1 m distance from unit and 1.60 m above reverberant floor, 120 bar (12 MPa) operating pressure.

3.8 Technical data for electric HC units

	HC 950 (0528501)	HC 950-SSP (0528503)	HC 970 (0528509)	HC 970-SSP (0528507)
Voltage				
230 V~, 50 Hz:	*	*		
400 V, 50 Hz, V3~:			*	*
Fuse protection				
16 A:	*	*	*	*
Power cord				
3 x 2.5 mm ² – 6 m:	*	*		
5 x 2.5 mm ² – 6 m:			*	*
Capacity				
3.6 kW:	*	*		
5.5 kW:			*	*
Max operating pressure				
25 MPa (250 bar):	*	*	*	*
Maximum volume flow				
6.6 l/min:	*	*		
10 l/min:			*	*
Volume flow at 12 MPa (120 bar)				
5.2 l/min:	*	*		
10 l/min:			*	*
Max. size of tip with a spray gun				
0.052 inch – 1.30 mm:	*	*		
0.056 inch – 1.42 mm:			*	*
Fluid outlet fitting				
3/8 inch – 9.5 mm:	*			
1/2 inch – 12.7 mm:		*	*	*
Max. temperature of the coating material				
43° C:	*	*	*	*
Max. Viscosity				
50.000 mPa·s:	*		*	
65.000 mPa·s:		*		*
Filter insert (standard equipment)				
0 Mesh:	*	*	*	*
Weight:				
83 kg	*			
84.5 kg		*		
100 kg			*	
103 kg				*
Hydraulic oil filling quantity				
4.7 l ISO 32:	*	*	*	*
Max. tire pressure				
0.2 MPa (2 bar):	*	*	*	*
Special high-pressure hose				
DN 10 mm, 15 m, connection thread NPSM 3/8:	*			
DN 13 mm, 15 m, connection thread NPSM 1/2:		*	*	*
Hose whip				
DN 10 mm, 2,5 m, connection thread NPSM 3/8:		*	*	*
Dimensions L x W x H				
1185 x 955 x 655 mm:	*	*		
1200 x 955 x 655 mm:			*	*
Max. sound pressure level:				
80 dB (A)*	*	*		
88 dB (A)*			*	*

* Place of measurement: 1 m distance from unit and 1.60 m above reverberant floor, 12 MPa (120 bar) operating pressure.

Description of unit

Operating Temperature

This equipment will operate correctly in its intended ambient, at a minimum between +10°C and +40°C.

Relative Humidity

The equipment will operate correctly within an environment at 50% RH, +40°C. Higher RH may be allowed at lower temperatures.

Measures shall be taken by the Purchaser to avoid the harmful effects of occasional condensation.

Altitude

This equipment will operate correctly up to 2100 m above mean sea level.

Transportation and Storage

This equipment will withstand, or has been protected against, transportation and storage temperatures of -25°C to +55°C and for short periods up to +70°C.

It has been packaged to prevent damage from the effects of normal humidity, vibration and shock.

3.9 Transport



Do not lift by cart handle when loading or unloading. Device is very heavy. Three-person lift is required.

Handle

Pull out the handle (fig. 5, item 1) until it will come no further. Push in the snap buttons (2) on the sides of the handle and insert the handle.

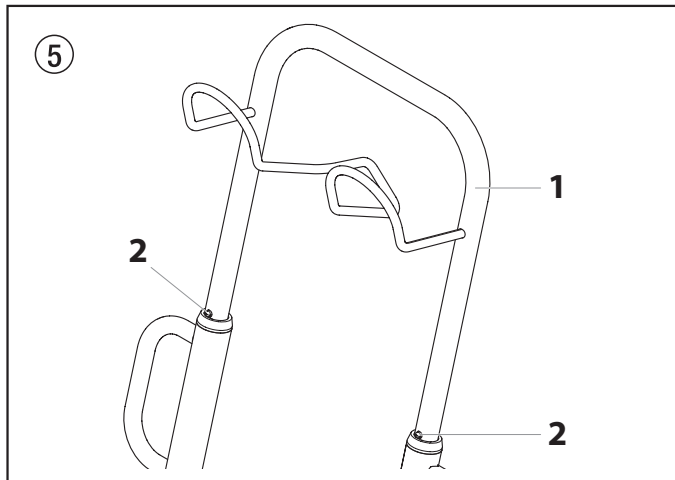

3.10 Transport in vehicle

Push locking pin (fig. 6, item 1) in the swivel mechanism (2) for the material feed pump (3) and swivel it to a horizontal position. Ensure that the locking pin locks.

Roll the high-pressure hose over the hose rack on the handle. Secure the unit with a suitable fastening.

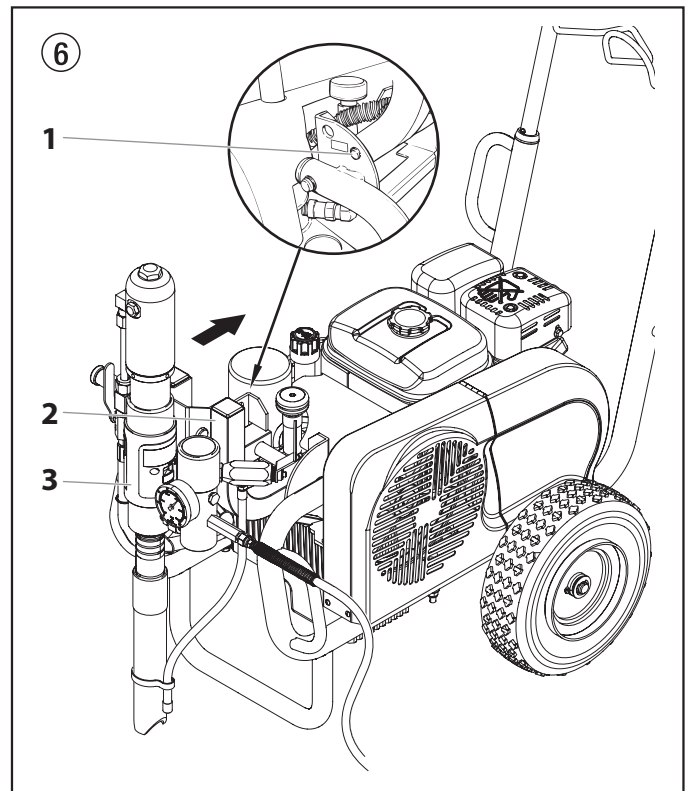

3.11 Crane transport

Hanging points for crane straps or ropes, see figure 7.

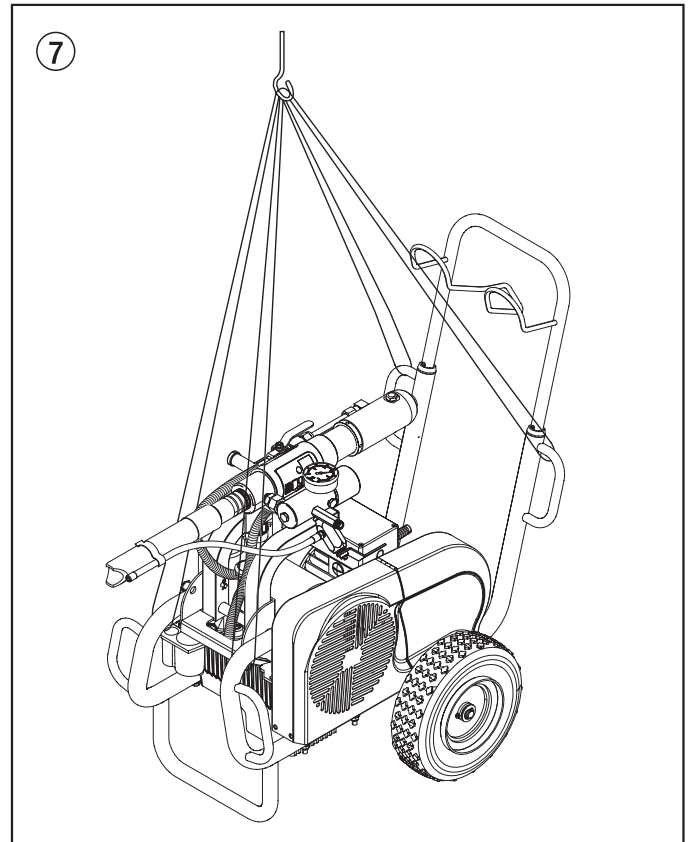

4. Starting operation

4.1 Changing the material feed pump position



Be careful, as the moving parts of the swivel mechanism can crush fingers and feet.

1. Grip handle (fig. 8, item 1) with one hand.
2. Push locking pin (2) with the other hand.
3. Swivel material feed pump up or down to the desired position, until the locking pin (2) locks into the new position.

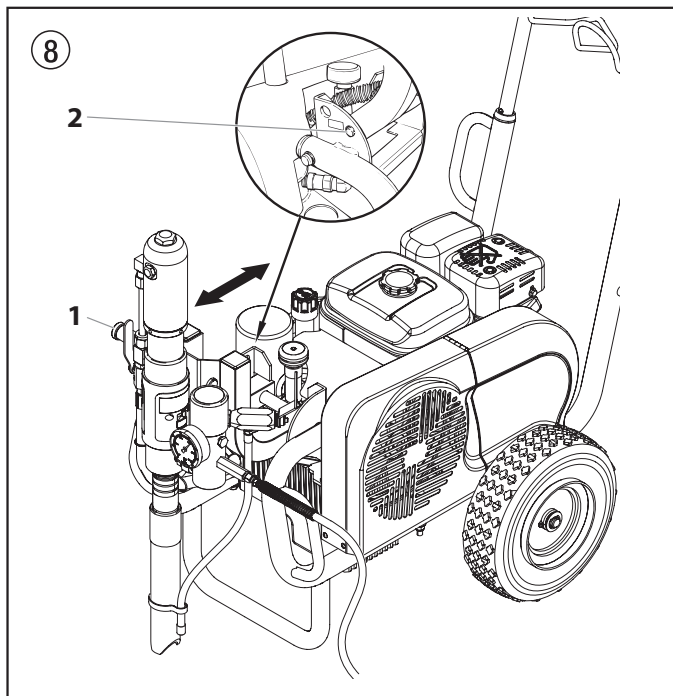

1. Transport position (fig. 9)

Transport unit only when the material feed pump is in the horizontal position.

Swiveling the material feed pump to a horizontal position also allows removal of the pump from the coating material container.

Ensure that the locking pin locks.

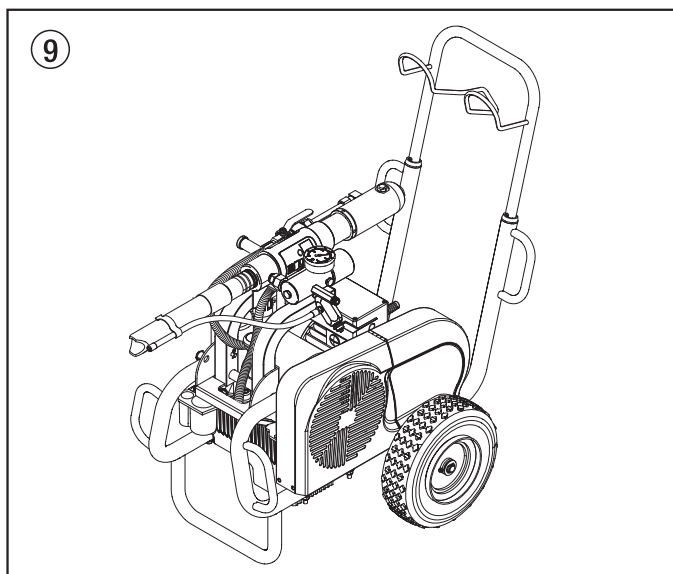

2. Operating position I (fig. 10)

Swiveling the material feed pump to a vertical position allows the material feed pump to be immersed in the coating material container.

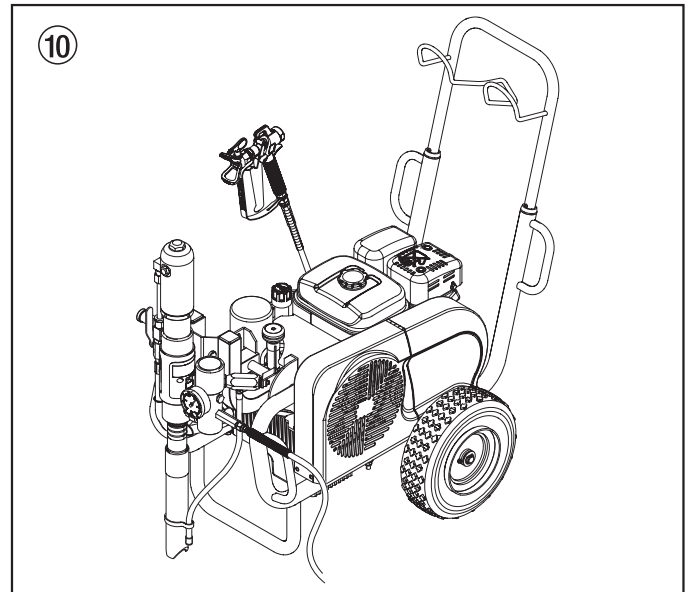

3. Operating position II (fig. 11)

Swivel material feed pump to a slanted (45°) position if using the container suction system (accessory). In this position, there is open space under the material feed pump.

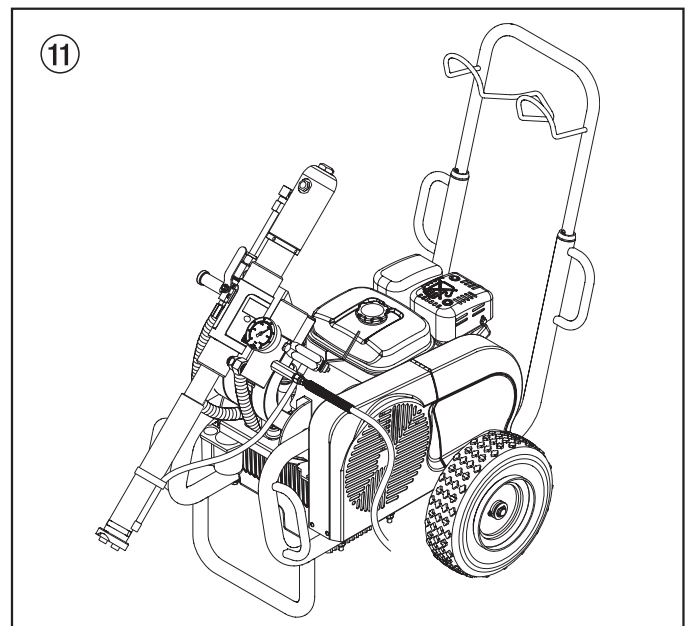

4.2 High-pressure hose, spray gun and separating oil

1. Screw the high-pressure hose (fig. 12, item 1) onto the hose connection (2).
2. Screw HC 950-SSP • HC 970 and HC 970-SSP double socket (3) into the high-pressure hose.
Screw on hose whip (4).
3. Screw connection socket (5) to the spray gun (6).
4. Screw spray gun with selected tip to the high-pressure hose or hose whip (4), depending on the model.
5. Tighten union nuts at high-pressure hose and, depending on the model, at the hose whip to prevent coating material from leaking.

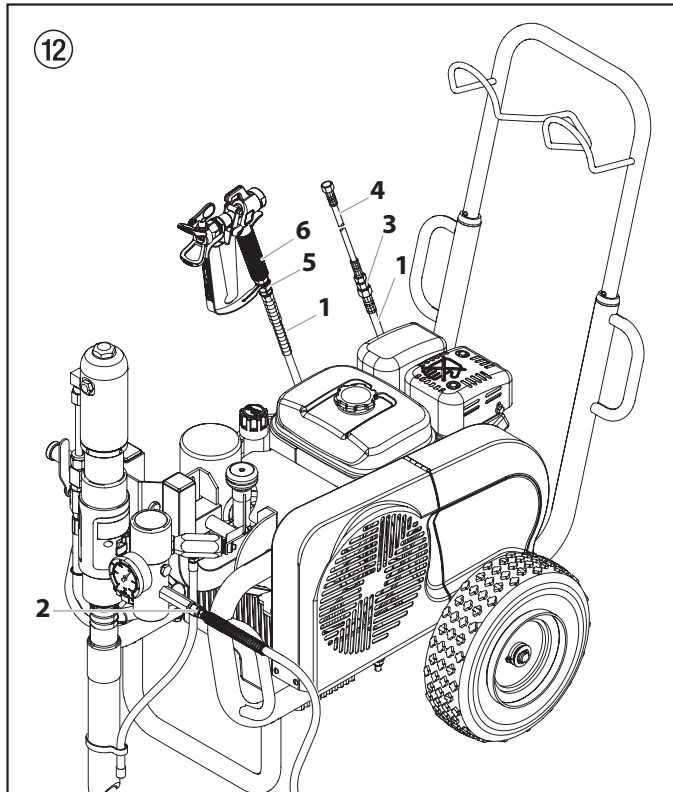

6. Fill in EasyGlide (fig. 13). Do not fill in too much separating oil, i.e. ensure that no separating oil drips into the coating material container.



EasyGlide prevents increased wear and tear to the packings.

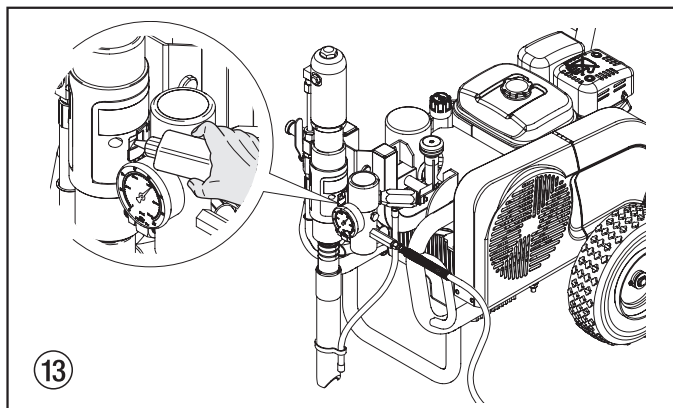

4.3 Gasoline engine (gas units only)

1. Fill in the supplied engine oil.
The gasoline engine is transported without engine oil. The oil-level sensor prevents the engine from being started when the oil level is too low.
For oil grades and quantities please refer to the engine instructions.
2. Fill the gasoline tank.
For information on the gasoline please refer to the engine instructions.

4.4 Connection to the mains (electric units only)



The connection must take place through a properly earthed two-pole and earth socket outlet.

Before connecting the unit to the mains supply, make sure that the line voltage matches the specifications on the unit's rating plate. The green indicator light will light up as soon as the mains plug has been connected.

4.5 Flushing preserving fluid during initial start-up

1. Push locking pin (fig. 14, item 1) and swivel material feed pump to a container with suitable cleaning agent.
2. Turn the pressure control knob (2) on the hydraulic pump to the left (pressure reduction) until it stops.
3. Turn the relief valve handle (3) fully counterclockwise (↺ Circulation).
4. Start the engine or turn on the electric motor.
 - a. To start the gas engine, refer to the engine manual.
 - b. To start the electric motor:
 - For HC 920 and HC 950 units, move the switch to "1" (ON).
 - For HC 970 units, first set the switch to "Y" and then to "Δ" (ON).



The direction of the rotation of the pulley must correspond to the arrow (4) on the belt cover. If the belt is running opposite the direction of the arrow: Switch unit to "O" (OFF). Unplug power plug and turn the polarity changer (5) in the power plug by 180° with a screwdriver. Plug in power plug again.

5. Move the hydraulic ball valve (6) on the material feed pump to its vertical position (open). This will switch on the hydraulic motor.
Hydraulic oil flows to the hydraulic motor of the material feed pump.
6. Turn the pressure control knob (2) to the right (pressure increase) until cleaning agent exits the return hose.
7. Turn relief valve handle (3) fully clockwise (↻ spray).
8. Pull the trigger of the spray gun.
9. Spray the cleaning agent from the unit into an open collecting container.

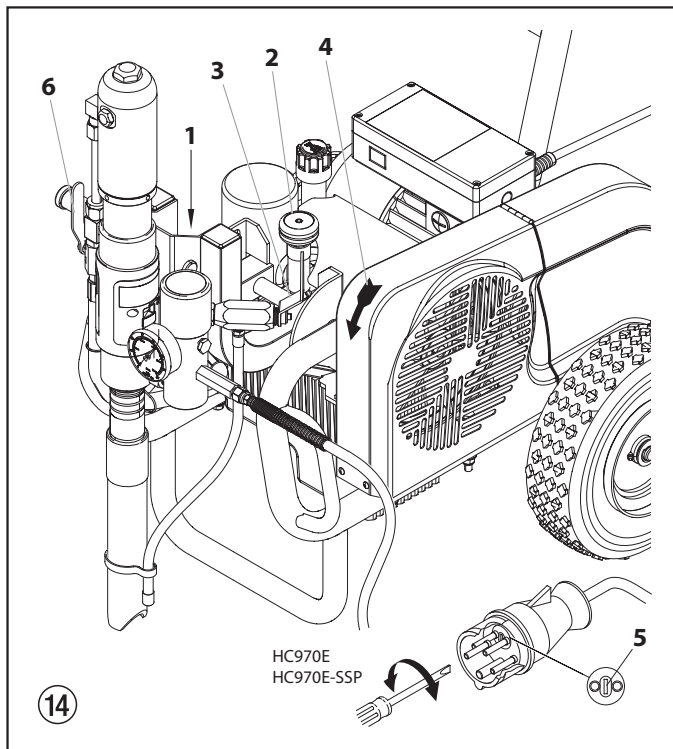

4.6 Taking the unit into operation with coating material



If the unit is located on a non-conductive surface (e.g. a wood floor), earth the unit with an earthing cable.

1. Push locking pin (fig. 14, item 1) and swivel material feed pump into the coating material container.
2. Turn the pressure control knob (2) on the hydraulic pump to the left (pressure reduction) until it stops.
3. Turn the relief valve handle (3) fully counterclockwise (↻ Circulation).
4. Start the engine or turn on the electric motor.
 - a. To start the gas engine, refer to the engine manual.
 - b. To start the electric motor:
 - For HC 950 units, move the switch to "1" (ON).
 - For HC 970 units, first set the switch to "Y" and then to "Δ" (ON).



The direction of the rotation of the pulley must correspond to the arrow (4) on the belt cover. If the belt is running opposite the direction of the arrow: Switch unit to "O" (OFF). Unplug power plug and turn the polarity changer (5) in the power plug by 180° with a screwdriver. Plug in power plug again.

5. Move the hydraulic ball valve (6) on the material feed pump to its vertical position (open). This will switch on the hydraulic motor.
Hydraulic oil flows to the hydraulic motor of the material feed pump.
6. Turn the pressure control knob (2) to the right (pressure increase) until coating material exits the return hose.
7. Turn relief valve handle (3) fully clockwise (↻ spray).
8. Pull the trigger of the spray gun, then set the desired operating pressure by means of the pressure control knob (2).
9. The unit is ready to spray.

5. Spraying technique

Move the spray gun evenly during the spraying process. Otherwise the spray pattern will be uneven. Carry out the spray movement with the arm, not with the wrist. Observe a parallel distance of approx. 30 cm between the spray gun and the object of spraying. The lateral edge of the spray jet should not be too distinct. The spray edge should be gradual in order to facilitate overlapping of the next coat. Always move the spray gun parallel and at an angle of 90° to the surface to be coated in order to minimize the paint mist.



If very sharp edges result or if there are streaks in the spray jet – increase the operating pressure or dilute the coating material.

6. Handling the high-pressure hose

The unit is equipped with a high-pressure hose specially suited for piston pumps.



**Danger of injury through leaking high-pressure hose. Replace any damaged high-pressure hose immediately.
Never repair defective high-pressure hoses yourself!**

The high-pressure hose is to be handled with care. Avoid sharp bends and folds: the smallest bending radius is about 20 cm.

Do not drive over the high-pressure hose. Protect against sharp objects and edges.

Never pull on the high-pressure hose to move the device.

Make sure that the high-pressure hose cannot twist. This can be avoided by using a Wagner spray gun with a swivel joint and a hose system.



When using the high-pressure hose while working on scaffolding, it is best to always guide the hose along the outside of the scaffolding.

The risk of damage rises with the age of the high-pressure hose. Wagner recommends replacing high-pressure hoses after 6 years.

Use only WAGNER original-high-pressure hoses in order to ensure functionality, safety and durability.

7. Interruption of work

1. Move the hydraulic ball valve on the material feed pump to its horizontal position (closed).
Flow of hydraulic oil to hydraulic motor of material feed pump is interrupted.
2. Turn the relief valve handle (3) fully counterclockwise (↻ Circulation).
3. Turn off the gasoline engine or electric motor.
4. Pull the trigger of the spray gun in order to release the pressure from the high-pressure hose and spray gun.
5. Secure the spray gun, refer to the operating manual of the spray gun.
6. If a standard tip is to be cleaned, see page 43, point 11.2.
If a non-standard tip is installed, proceed according to the relevant operating manual.
7. Leave the suction tube immersed in the coating material or immerse it in the corresponding cleaning agent.



Attention

If fast-drying or two-component coating material is used, ensure that the unit is rinsed with a suitable cleaning agent within the processing time.

8. Cleaning the unit (shutting down)

A clean state is the best method of ensuring operation without problems. After you have finished spraying, clean the unit. Under no circumstances may any remaining coating material dry and harden in the unit.

The cleaning agent used for cleaning (only with an ignition point above 21 °C) must be suitable for the coating material used.

- Secure the spray gun, refer to the operating manual of the spray gun.

Clean and remove tip.

For a standard tip, refer to page 43, point 11.2.

If a non-standard tip is installed, proceed according to the relevant operating manual.

1. Push locking pin and swivel material feed pump out of coating material.
2. Pull the trigger of the spray gun in order to pump the remaining coating material from the suction tube, high-pressure hose and the spray gun into an open container.



Attention

The container must be earthed in case of coating materials which contain solvents.



Caution! Do not pump or spray into a container with a small opening (bunghole)! Refer to the safety regulations.

3. Push locking pin and swivel material feed pump to a container with suitable cleaning agent.
4. Turn the relief valve handle fully counterclockwise (↺ Circulation).
5. Pump a suitable cleaning agent in the circuit for a few minutes.
6. Turn relief valve handle fully clockwise (→ spray).
7. Pump the remaining cleaning agent into an open container until the unit is empty.
8. Turn the relief valve handle fully counterclockwise (↺ Circulation).
9. Move the hydraulic ball valve on the material feed pump to its horizontal position (closed).
10. Turn off the gasoline engine or electric motor.

8.1 Cleaning the unit from the outside



Gasoline units — Switch off the gasoline engine and let it cool down.

Electric units — Unplug the mains plug from the socket.

Danger of short-circuits through penetrating water.

Never spray down the unit with high-pressure or high-pressure steam cleaners.



Attention

Do not put the high-pressure hose into solvents. Use only a wet cloth to wipe down the outside of the hose.

Wipe the unit off with a cloth soaked in a suitable cleaning agent.

8.2 Cleaning the high-pressure filter

Clean the filter cartridge regularly.

A soiled or clogged high-pressure filter can cause a poor spray pattern or a clogged tip.

Disassembly

1. Move the hydraulic ball valve on the material feed pump to its horizontal position (closed).
Flow of hydraulic oil to hydraulic motor of material feed pump is interrupted.
2. Turn the relief valve handle fully counterclockwise (↺ Circulation).
3. Turn off the gasoline engine or electric motor.
4. Unscrew the housing cover (fig. 15, item 1).
5. Pull filter cartridge (3) out of housing (8).
6. Clean the pressure spring (2) and filter cartridge (3) with an appropriate cleaning agent, clean the inside of the housing (8) and housing cover (1).
7. Check ball in the filter cartridge (3) for wear and replace filter cartridge, if necessary.
8. If ball in filter cartridge (3) is thoroughly worn, remove O-ring (6) and valve seat (7). Replace worn valve seat, if necessary.
9. **Always replace O-ring (6) after removal.**
10. Pull off pressure spring (2) from housing cover (1).
Measure length of pressure spring, and replace if shorter than 19 mm.

Assembly

1. Insert valve seat (7) with the ball seat surface facing up into the housing (8).
2. Insert O-ring (6) into the housing (8).
3. Insert filter cartridge (3).
4. Place thin seal (5) on threaded section of housing (8).
5. Place thick seal (4) on top of thin seal (5).
6. Slide pressure spring (2) onto housing cover pin (2).
7. Screw on housing cover (1) and tighten by hand.

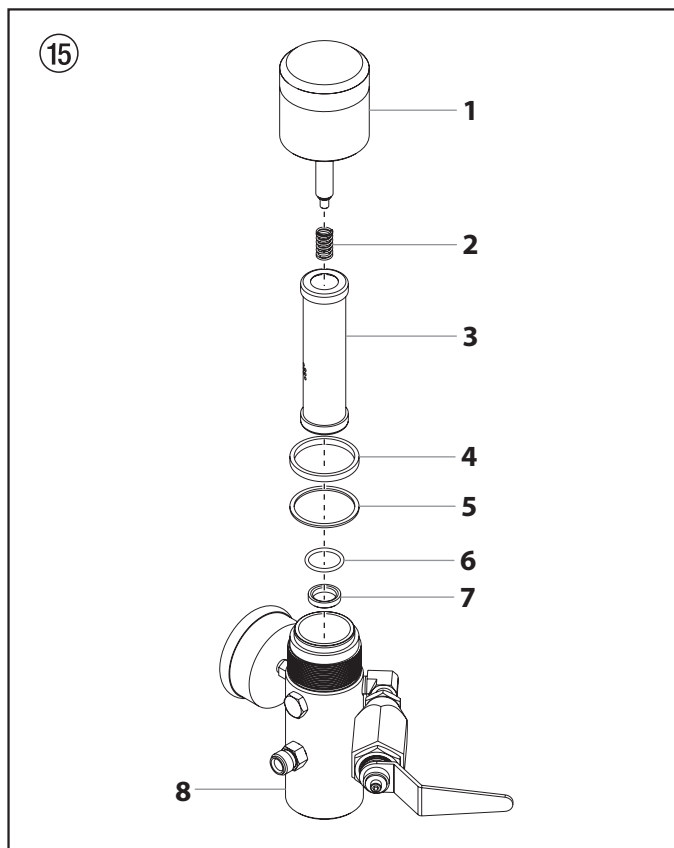

8.3 Cleaning Airless spray gun

- Rinse Airless spray gun with an appropriate cleaning agent.
- Clean tip thoroughly with appropriate cleaning agent so that no coating material residue remains.
- Thoroughly clean the outside of the Airless spray gun.

Intake filter in Airless spray gun (fig. 16)

Dismounting

1. Pull protective guard (1) forward vigorously.
2. Screw handle (2) out of the gun housing. Remove intake filter (3).
3. Intake filter congested or defective – replace.

Mounting

1. Place intake filter (3) with the long cone into the gun housing.
2. Screw handle (2) into the gun housing and tighten.
3. Snap in protective guard (1).

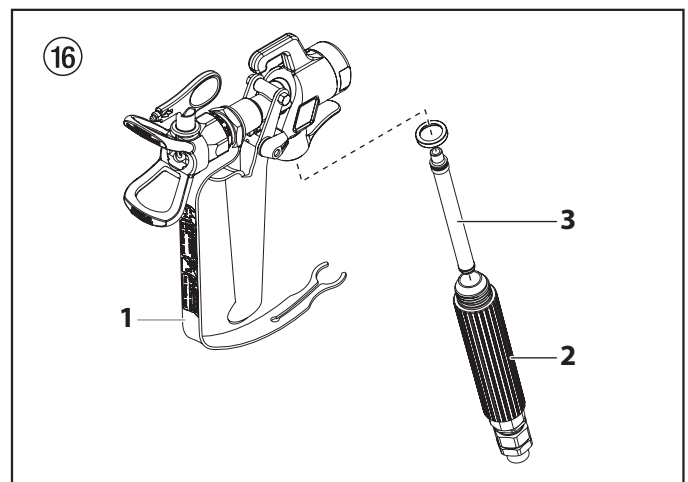

9.1 Gasoline engine

Type of malfunction	Possible cause	Measures for eliminating the malfunction
A. Gasoline engine does not start up	<ol style="list-style-type: none"> No gasoline. ON/OFF switch to OFF. Gasoline cock closed. Engine problem. Engine defective. Oil level insufficient. 	<ol style="list-style-type: none"> Fill the gasoline tank. Move the switch to ON. Open the gasoline cock. Please refer to the engine instructions. Bring to the Honda service point. Top off oil.

9.2 Electric Motor

Type of malfunction	Possible cause	Measures for eliminating the malfunction
A. Unit does not start	<ol style="list-style-type: none"> Indicator light does not indicate unit has power. The unit has switched off automatically because of an overload. 	<ol style="list-style-type: none"> Check power supply. Wait 2 – 3 minutes, then turn the unit back on.
B. HC 970 units: Piston rod in the material feed pump is not moving up and down.	<ol style="list-style-type: none"> Direction of the rotation of the electric motor is incorrect 	<ol style="list-style-type: none"> Turn the polarity changer in the power plug 180°.

9.3 Hydraulic motor

Type of malfunction	Possible cause	Measures for eliminating the malfunction
A. Hydraulic motor stuck in the lower position.	<ol style="list-style-type: none"> Outlet valve seat in the material feed pump is loose. Reversing valve in the hydraulic motor is stuck or the upper or lower hexagonal nut on the valve rod has become loose. 	<ol style="list-style-type: none"> Ball valve on the material feed pump – lever position vertical. Screw out sealing screw on hydraulic motor. Press down reversing valve on hydraulic motor. Remount sealing screw. Start unit. The piston rod moves upward and then gets stuck in the lower position. The cause is a loose outlet valve seat. Take unit to a Wagner authorized service center.
B. Hydraulic motor stuck in the upper position.	<ol style="list-style-type: none"> Reversing valve is stuck. Pressure spring on valve rod is broken. Pressure spring stop on valve rod is broken. Air in the hydraulic motor. Air in the material feed pump. 	<ol style="list-style-type: none"> Take unit to a Wagner authorized service center. Take unit to a Wagner authorized service center. Take unit to a Wagner authorized service center. Turn back pressure control knob. Vent air at low pressure during a 5 – 10 minute endurance run. Do not let the material feed pump run dry. <p>Check for leaks:</p> <ul style="list-style-type: none"> • Loose connections on hydraulic oil tank • Loose connections on the hydraulic oil pump • Loose hydraulic oil hose connections • Level of oil in hydraulic tank is too low <ol style="list-style-type: none"> Ball valve on the material feed pump – lever position vertical. Screw out sealing screw on hydraulic motor. Press down reversing valve on hydraulic motor. Remount sealing screw. Start unit. Prevent the material feed pump from sucking up air.
C. Low pressure. The piston rod moves correctly in the downward stroke, but the upward stroke is sluggish. The outside of the hydraulic motor is very hot.	<ol style="list-style-type: none"> Faulty piston packing in hydraulic motor. Piston rod is broken. 	<ol style="list-style-type: none"> Take unit to a Wagner authorized service center. Take unit to a Wagner authorized service center.
D. Low pressure. The outside of the hydraulic motor becomes very hot when stroking upward and downward.	<ol style="list-style-type: none"> Middle O-ring on reversing valve is faulty. Packings in the material feed pump are worn. 	<ol style="list-style-type: none"> Take unit to a Wagner authorized service center. Replace

9.4 Material feed pump

Type of malfunction	Possible cause	Measures for eliminating the malfunction
A. A sufficient amount of coating material is ejected only with an upward stroke, or upward motion of the piston rod is slow and downward motion is fast	<ol style="list-style-type: none"> Inlet valve is leaky due to impurities or wear. Coating material viscosity is too high, preventing it from being sucked up. 	<ol style="list-style-type: none"> Clean and check the inlet valve housing. Insert ball and fill with water; if leaky, replace ball. Thin out according to the manufacturer's instructions.
B. A sufficient amount of coating material is ejected only with a downward stroke, or downward motion of the piston rod is slow and upward motion is fast.	<ol style="list-style-type: none"> Outlet valve leaky. Lower packing is worn. 	<ol style="list-style-type: none"> Dismantle and check outlet valve seat. Insert ball and fill with water; if leaky, replace ball. Replace.
C. Piston rod moves up and down quickly.	<ol style="list-style-type: none"> Suction tube projects over the fluid level and sucks in air. Coating material viscosity is too high, preventing it from being sucked up. Ball in inlet valve housing is stuck. 	<ol style="list-style-type: none"> Refill the coating material Thin out the coating material according to manufacturer's instructions. Vent air from material feed pump and turn the relief valve knob to the left (↻ Circulation).
D. Piston rod moves up and down slowly when the spray gun is closed.	<ol style="list-style-type: none"> Loose connections. Relief valve is not closed completely. Relief valve worn. Lower packing worn. Ball in inlet valve housing and ball in outlet valve seat are not sealing properly. 	<ol style="list-style-type: none"> Dismantle inlet valve housing, clean ball and valve seat. Check all connections between the material feed pump and spray gun. Turn relief valve handle (3) fully clockwise (→ spray). Replace If the measures described above do not help, replace lower packing. Dismantle inlet valve housing and outlet valve seat. Clean balls and valve seats.
E. Not enough pressure to the spray gun.	<ol style="list-style-type: none"> Tip is worn. Filter cartridge in high-pressure filter is clogged. High-pressure hose is too long. 	<ol style="list-style-type: none"> Replace Clean or replace the filter cartridge. Reduce length.
F. Piston rod sputters when stroking upward or downward.	<ol style="list-style-type: none"> Solvent has made the upper packing expand. 	<ol style="list-style-type: none"> Replace upper packing.

10. Servicing

10.1 General servicing

The unit should be serviced once a year by the Wagner Service.

1. For servicing of the gasoline engine, refer to the engine instructions.
2. Check the high-pressure hoses for damage.
3. Check the inlet and outlet vents for wear.
4. Check oil level in hydraulic oil tank.
5. Carry out an oil change if necessary.

10.2 Checking the oil level in the hydraulic oil tank



Gasoline units — Check oil level daily.



Electric units — Switch off unit "O" (OFF). Remove the mains plug from the socket.

1. Turn oil measuring stick (fig. 17, item 1) to the left and pull out.
2. The oil level should be visible between the marking (see arrows) on the oil measuring stick.
3. If necessary, refill oil. For information on the oil grade, refer to the oil change section, chapter 10.3.

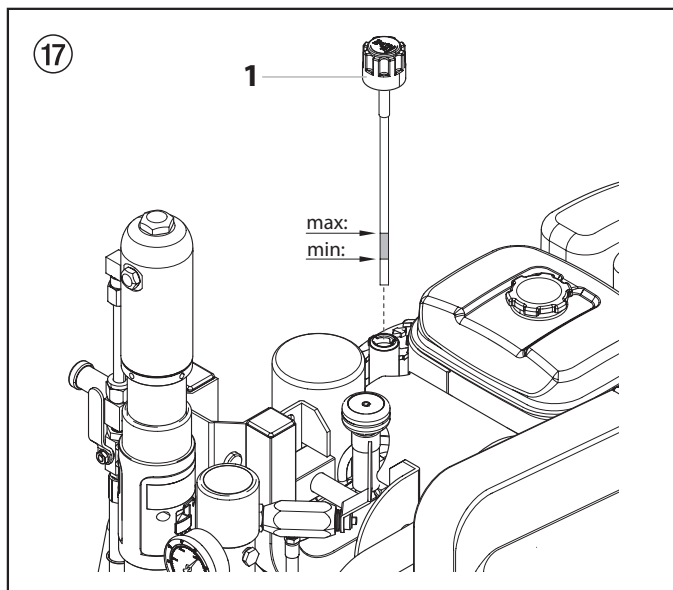

10.3 Oil and oil filter change of the hydraulic oil pump

Carry out oil and oil filter change once every 12 months.



Danger to the environment
Do not dispose of waste oil into the sewer or soil. Polluting the ground water is a crime. Waste oil can be returned where hydraulic oil is bought.



Carry out an oil change while the unit is still warm from operation.



Electric units — Switch off unit "O" (OFF). Remove the mains plug from the socket.

1. Turn off the gasoline engine or electric motor.
2. Move the hydraulic ball valve (fig. 18, item 1) on the material feed pump to its vertical position (open).
3. Remove the screws on the hydraulic oil pump cover (2) and remove cover.
4. Turn oil measuring stick (3) to the left and pull out.
5. Screw out oil filter (4) with a strap spanner and replace.
6. Screw out sealing screw (5) under the hydraulic oil tank. Drain the waste oil.
7. Replace the sealing screw into the hydraulic oil tank.
8. Fill in 4.7 liters of ESSO ISO 32 hydraulic oil.



When oil is filled in, air can enter the hydraulic system. Therefore, the system must be vented.

9. Let the unit run for at least five minutes at low pressure to automatically bleed the air from the hydraulic system.

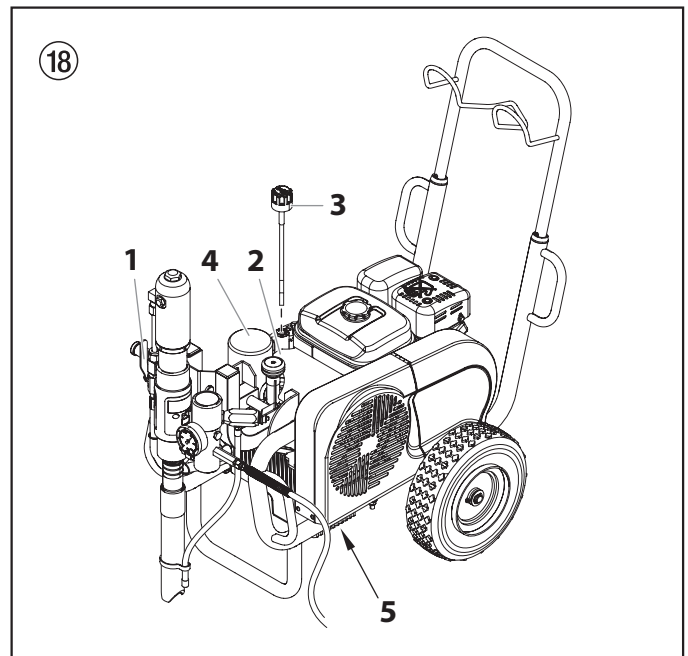

10.4 High-pressure hose

Inspect the high-pressure hose visually for any notches or bulges, in particular at the transition in the fittings. It must be possible to turn the union nuts freely.



The risk of damage rises with the age of the high-pressure hose. Wagner recommends replacing high-pressure hoses after 6 years.

11. Appendix

11.1 Selection of tip

To achieve faultless and rational working, the selection of the tip is of the greatest importance. In many cases the correct tip can only be determined by means of a spraying test.

Some rules for this:

The spray jet must be even.

If streaks appear in the spray jet the spraying pressure is either too low or the viscosity of the coating material too high.

Remedy: Increase pressure or dilute coating material. Each pump conveys a certain quantity in proportion to the size of the tip:

The following principle is valid:
 large tip = low pressure
 small tip = high pressure

There is a large range of tips with various spraying angles.

11.2 Servicing and cleaning of Airless hard-metal tips

Standard tips

If a different tip type has been fitted, then clean it according to manufacturer's instructions.

The tip has a bore processed with the greatest precision. Careful handling is necessary to achieve long durability. Do not forget the fact that the hard-metal insert is brittle! Never throw the tip or handle with sharp metal objects.

The following points must be observed to keep the tip clean and ready for use:

1. Turn the relief valve handle fully counterclockwise (↺ Circulation).
2. Switch off the gasoline engine.
3. Dismount the tip from the spray gun.
4. Place tip in an appropriate cleaning agent until all coating material residue is dissolved.
5. If there is pressure air, blow out tip.
6. Remove any residue by means of a sharp wooden rod (toothpick).
7. Check the tip with the help of a magnifying glass and, if necessary, repeat points 4 to 6.

11.3 Spray gun accessories

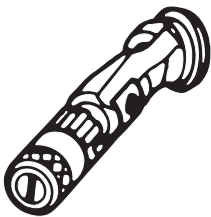

Flat jet adjusting tip
 up to 250 bar (25 MPa)

Tip marking	Bore mm	Spray width at about 30 cm removal of spray object Pressure 100 bar (10 MPa)	Use	Flat jet adjusting tip Order No.
15	0.13 - 0.46	5 - 35 cm	Paints	0999 057
20	0.18 - 0.48	5 - 50 cm	Paints, fillers	0999 053
28	0.28 - 0.66	8 - 55 cm	Paints, dispersions	0999 054
41	0.43 - 0.88	10 - 60 cm	Rust protection paints - dispersions	0999 055
49	0.53 - 1.37	10 - 40 cm	Large-area coats	0999 056

Contact protection for the flat jet adjustment tip

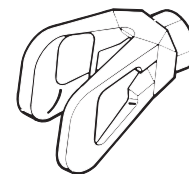

Order No. **0097 294**

Tip extension with slewable knee joint (without tip)

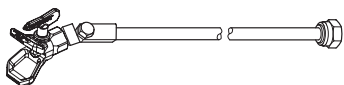

- Length: 100 cm Order no. **0096 015**
- Length: 200 cm Order no. **0096 016**
- Length: 300 cm Order no. **0096 017**

Tip extension

- 15 cm, F-thread, Order no. **0556 051**
- 30 cm, F-thread, Order no. **0556 052**
- 45 cm, F-thread, Order no. **0556 053**
- 60 cm, F-thread, Order no. **0556 054**

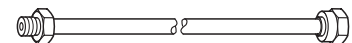

- 15 cm, G-thread, Order no. **0556 074**
- 30 cm, G-thread, Order no. **0556 075**
- 45 cm, G-thread, Order no. **0556 076**
- 60 cm, G-thread, Order no. **0556 077**

11.4 Airless tip table

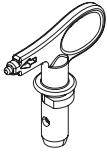

Wagner TradeTip 3 tip
up to 270 bar
(27 MPa)

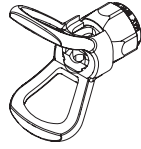

without tip
F thread (11/16 - 16 UN)
for Wagner spray guns
Order no. 0289391

without tip
G thread (7/8 - 14 UN)
for Graco/Titan spray guns
Order no. 0289390



All of the tips in the table below are supplied together with the appropriate gun filter.

Application	Tip marking	Spray angle	Bore inch / mm	Spraying width mm 1)	Gun filter	Order no.
Water-thinnable and solvent-based paints and varnishes, oils, separating agents	107	10°	0.007 / 0.18	100	red	0553107
	207	20°	0.007 / 0.18	120	red	0553207
	307	30°	0.007 / 0.18	150	red	0553307
	407	40°	0.007 / 0.18	190	red	0553407
	109	10°	0.009 / 0.23	100	red	0553109
	209	20°	0.009 / 0.23	120	red	0553209
	309	30°	0.009 / 0.23	150	red	0553309
	409	40°	0.009 / 0.23	190	red	0553409
	509	50°	0.009 / 0.23	225	red	0553509
	609	60°	0.009 / 0.23	270	red	0553609
Synthetic-resin paints PVC paints	111	10°	0.011 / 0.28	100	red	0553111
	211	20°	0.011 / 0.28	120	red	0553211
	311	30°	0.011 / 0.28	150	red	0553311
	411	40°	0.011 / 0.28	190	red	0553411
	511	50°	0.011 / 0.28	225	red	0553511
	611	60°	0.011 / 0.28	270	red	0553611
Paints, primers Fillers	113	10°	0.013 / 0.33	100	red	0553113
	213	20°	0.013 / 0.33	120	red	0553213
	313	30°	0.013 / 0.33	150	red	0553313
	413	40°	0.013 / 0.33	190	red	0553413
	513	50°	0.013 / 0.33	225	red	0553513
	613	60°	0.013 / 0.33	270	red	0553613
	813	80°	0.013 / 0.33	330	red	0553813
	Fillers Rust protection paints	115	10°	0.015 / 0.38	100	yellow
215		20°	0.015 / 0.38	120	yellow	0553215
315		30°	0.015 / 0.38	150	yellow	0553315
415		40°	0.015 / 0.38	190	yellow	0553415
515		50°	0.015 / 0.38	225	yellow	0553515
615		60°	0.015 / 0.38	270	yellow	0553615
715		70°	0.015 / 0.38	300	yellow	0553715
815		80°	0.015 / 0.38	330	yellow	0553815
Rust protection paints Latex paints Dispersions	117	10°	0.017 / 0.43	100	yellow	0553117
	217	20°	0.017 / 0.43	120	yellow	0553217
	317	30°	0.017 / 0.43	150	yellow	0553317
	417	40°	0.017 / 0.43	190	yellow	0553417
	517	50°	0.017 / 0.43	225	yellow	0553517
	617	60°	0.017 / 0.43	270	yellow	0553617
	717	70°	0.017 / 0.43	300	yellow	0553717
	817	80°	0.017 / 0.43	330	yellow	0553817
Rust protection paints Latex paints Dispersions	219	20°	0.019 / 0.48	120	white	0553219
	319	30°	0.019 / 0.48	150	white	0553319
	419	40°	0.019 / 0.48	190	white	0553419
	519	50°	0.019 / 0.48	225	white	0553519
	619	60°	0.019 / 0.48	270	white	0553619
	719	70°	0.019 / 0.48	300	white	0553719
	819	80°	0.019 / 0.48	330	white	0553819
	919	90°	0.019 / 0.48	385	white	0553919
	Flame retardant	221	20°	0.021 / 0.53	120	white
321		30°	0.021 / 0.53	150	white	0553321
421		40°	0.021 / 0.53	190	white	0553421
521		50°	0.021 / 0.53	225	white	0553521
621		60°	0.021 / 0.53	270	white	0553621
721		70°	0.021 / 0.53	300	white	0553721
821		80°	0.021 / 0.53	330	white	0553821

1) Spray width at about 30 cm to the object and 100 bar (10 MPa) pressure with synthetic-resin paint 20 DIN seconds.

Application	Tip marking	Spray angle	Bore inch / mm	Spraying width mm 1)	Gun filter	Order no.
Roof coatings	223	20°	0.023 / 0.58	120	white	0553223
	323	30°	0.023 / 0.58	150	white	0553323
	423	40°	0.023 / 0.58	190	white	0553423
	523	50°	0.023 / 0.58	225	white	0553523
	623	60°	0.023 / 0.58	270	white	0553623
	723	70°	0.023 / 0.58	300	white	0553723
	823	80°	0.023 / 0.58	330	white	0553823
	Thick-film materials, Corrosion protection Spray filler	225	20°	0.025 / 0.64	120	white
325		30°	0.025 / 0.64	150	white	0553325
425		40°	0.025 / 0.64	190	white	0553425
525		50°	0.025 / 0.64	225	white	0553525
625		60°	0.025 / 0.64	270	white	0553625
725		70°	0.025 / 0.64	300	white	0553725
825		80°	0.025 / 0.64	330	white	0553825
227		20°	0.027 / 0.69	120	white	0553227
327		30°	0.027 / 0.69	150	white	0553327
427		40°	0.027 / 0.69	190	white	0553427
527		50°	0.027 / 0.69	225	white	0553527
627		60°	0.027 / 0.69	270	white	0553627
827		80°	0.027 / 0.69	330	white	0553827
229		20°	0.029 / 0.75	120	white	0553229
329		30°	0.029 / 0.75	150	white	0553329
429		40°	0.029 / 0.75	190	white	0553429
529		50°	0.029 / 0.75	225	white	0553529
629		60°	0.029 / 0.75	270	white	0553629
231		20°	0.031 / 0.79	120	white	0553231
331		30°	0.031 / 0.79	150	white	0553331
431		40°	0.031 / 0.79	190	white	0553431
531		50°	0.031 / 0.79	225	white	0553531
631		60°	0.031 / 0.79	270	white	0553631
731		70°	0.031 / 0.79	300	white	0553731
831		80°	0.031 / 0.79	330	white	0553831
233		20°	0.033 / 0.83	120	white	0553233
333		30°	0.033 / 0.83	150	white	0553333
433		40°	0.033 / 0.83	190	white	0553433
533		50°	0.033 / 0.83	225	white	0553533
633		60°	0.033 / 0.83	270	white	0553633
235		20°	0.035 / 0.90	120	white	0553235
335		30°	0.035 / 0.90	150	white	0553335
435		40°	0.035 / 0.90	190	white	0553435
535		50°	0.035 / 0.90	225	white	0553535
635		60°	0.035 / 0.90	270	white	0553635
735	70°	0.035 / 0.90	300	white	0553735	
439	40°	0.039 / 0.99	190	white	0553439	
539	50°	0.039 / 0.99	225	white	0553539	
639	60°	0.039 / 0.99	270	white	0553639	
Heavy duty applications	243	20°	0.043 / 1.10	120	green	0553243
	443	40°	0.043 / 1.10	190	green	0553443
	543	50°	0.043 / 1.10	225	green	0553543
	643	60°	0.043 / 1.10	270	green	0553643
	445	40°	0.045 / 1.14	190	green	0553445
	545	50°	0.045 / 1.14	225	green	0553545
	645	60°	0.045 / 1.14	270	green	0553645
	451	40°	0.051 / 1.30	190	green	0553451
	551	50°	0.051 / 1.30	225	green	0553551
	651	60°	0.051 / 1.30	270	green	0553651
	252	20°	0.052 / 1.32	120	green	0553252
	455	40°	0.055 / 1.40	190	green	0553455
	555	50°	0.055 / 1.40	225	green	0553555
	655	60°	0.055 / 1.40	270	green	0553655
	261	20°	0.061 / 1.55	120	green	0553261
	461	40°	0.061 / 1.55	190	green	0553461
	561	50°	0.061 / 1.55	225	green	0553561
	661	60°	0.061 / 1.55	270	green	0553661
	263	20°	0.063 / 1.60	120	green	0553263
	463	40°	0.063 / 1.60	190	green	0553463
	565	50°	0.065 / 1.65	225	green	0553565
	665	60°	0.065 / 1.65	270	green	0553665
	267	20°	0.067 / 1.70	120	green	0553267
	467	40°	0.067 / 1.70	190	green	0553467

1)Spray width at about 30 cm to the object and 100 bar (10 MPa) pressure with synthetic-resin paint 20 DIN seconds.

11.5 2Speed Tip table

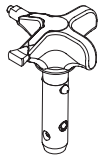

The innovative changeover nozzle from WAGNER combines two nozzle cores into one nozzle.

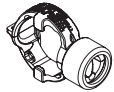

2 Speed Tip holder
Order no. 0271065

Tip table

Object size	Painting material		
	Lacquer (L)	Emulsion (D)	Filler (S)
Small		D5 Nozzles: 111 / 415 Order no. 0271 062	S5 Nozzles: 225 / 629 Order no. 0271 064
		D7 Nozzles: 113 / 417 Order no. 0271 063	
	L10 Nozzles: 208 / 510 Order no. 0271 042	D10 Nozzles: 111 / 419 Order no. 0271 045	S10 Nozzles: 527 / 235 Order no. 0271 049
Medium	L20 Nozzles: 210 / 512 Order no. 0271 043	D20 Nozzles: 115 / 421 Order no. 0271 046	S20 Nozzles: 539 / 243 Order no. 0271 050
Large	L30 Nozzles: 212 / 514 Order no. 0271 044	D30 Nozzles: 115 / 423 Order no. 0271 047	S30 Nozzles: 543 / 252 Order no. 0271 051
X-Large		D40 Nozzles: 117 / 427 Order no. 0271 048	
Recommended gun filter	red	white	-

- A** J. Wagner Ges.m.b.H.
Ottogasse 2/20
2333 Leopoldsdorf
Österreich
Tel. +43/ 2235 / 44 158
Telefax +43/ 2235 / 44 163
office@wagner-group.at
- B** WSB Finishing Equipment
Veilinglaan 56-58
1861 Wolvertem
Belgium
Tel. +32/2/269 46 75
Telefax +32/2/269 78 45
info@wagner-wsb.nl
- CH** Wagner International AG
Industriestrasse 22
9450 Altstätten
Schweiz
Tel. +41/71 / 7 57 22 11
Telefax +41/71 / 7 57 22 22
wagner@wagner-group.ch
- D** J. Wagner GmbH
Otto-Lilienthal-Straße 18
D-88677 Markdorf
Postfach 11 20
Deutschland
Tel. +49 / 75 44 / 505-1664
Telefax +49 / 75 44 / 505-1155
wagner@wagner-group.com
www.wagnergroup.com
- DK** Wagner Spraytech
Scandinavia A/S
Helgeshøj Allé 28
2630 Taastrup
Denmark
Tel. +45/43/ 27 18 18
Telefax +45/43/ 43 05 28
wagner@wagner-group.dk
- E** Wagner Spraytech Iberica S.A.
P.O. Box 132, Crta. N-340
08750 Molins de Rey
Barcelona / Espania
Tel. +34/93/6800028
Telefax +34/93/66800555
info@wagnerspain.com
- F** Wagner France
12 Avenue des Tropiques
Z.A. de Courtaboeuf,
91978 Les Ulis Cedex
France
Tel. 0 825 011 111
Telefax +33 (0) 69 81 72 57
division.batiment@wagner-france.fr
- CZ** Wagner, spol. s r.o.
Nedasovská str. 345
155 21 Praha 5 -Zlicín
Czechia
Tel. +42/ 2 / 579 50 412
Telefax +42/ 2 / 579 51 052
info@wagner.cz
- GB** Wagner Spraytech (UK) Limited
The Coach House
2 Main Road
Middleton Cheney OX17 2ND
Great Britain
UK-Helpline 0844 335 0517
5 p per minute (landline)
- I** Wagner Colora Srl
Via Italia 34
20060 Gessate - MI
Italia
Tel. +39 02.9592920.1
Telefax +39 02.95780187
info@wagnercolora.com
- NL** WSB Finishing Equipment BV
De Heldinnenlaan 200
3543 MB Utrecht
Netherlands
Tel. +31/ 30/241 41 55
Telefax +31/ 30/241 17 87
info@wagner-wsb.nl
- S** Wagner Spraytech
Scandinavia A/S
Helgeshøj Allé 28
2630 Taastrup
Denmark
Tel. +45/43/ 21 18 18
Telefax +45/43/ 43 05 28
wagner@wagner-group.dk

www.wagner-group.com

Important notes on product liability

As a result of an EC regulation being effective as from January 1, 1990, the manufacturer shall only be liable for his product if all parts come from him or are released by him, and if the devices are properly mounted and operated.

If the user applies outside accessories and spare parts, the manufacturer's liability can fully or partially be inapplicable; in extreme cases usage of the entire device can be prohibited by the competent authorities (employer's liability insurance association and factory inspectorate division).

Only the usage of original WAGNER accessories and spare parts guarantees that all safety regulations are observed.

3+2 years guarantee for professional finishing

Wagner professional guarantee
(Status 01.02.2009)

1. Scope of guarantee

All Wagner professional colour application devices (hereafter referred to as products) are carefully inspected, tested and are subject to strict checks under Wagner quality assurance. Wagner exclusively issues extended guarantees to commercial or professional users (hereafter referred to as "customer") who have purchased the product in an authorised specialist shop, and which relate to the products listed for that customer on the Internet under www.wagner-group.com/profi-guarantee.

The buyer's claim for liability for defects from the purchase agreement with the seller as well as statutory rights are not impaired by this guarantee.

We provide a guarantee in that we decide whether to replace or repair the product or individual parts, or take the device back and reimburse the purchase price. The costs for materials and working hours are our responsibility. Replaced products or parts become our property.

2. Guarantee period and registration

The guarantee period amounts to 36 months. For industrial use or equal wear, such as shift operations in particular, or in the event of rentals it amounts to 12 months.

Systems driven by petrol or air are also guaranteed for a 12 month period.

The guarantee period begins with the day of delivery by the authorised specialist shop. The date on the original purchase document is authoritative.

For all products bought in authorised specialist shops from 01.02.2009 the guarantee period is extended to 24 months providing the buyer of these devices registers in accordance with the following conditions within 4 weeks of the day of delivery by the authorised specialist shop.

Registration can be completed on the Internet under www.wagner-group.com/profi-guarantee. The guarantee certificate is valid as confirmation, as is the original purchase document that carries the date of the purchase. Registration is only possible if the buyer is in agreement with having the data being stored that is entered during registration.

When services are carried out under guarantee the guarantee period for the product is neither extended nor renewed.

Once the guarantee period has expired, claims made against the guarantee or from the guarantee can no longer be enforced.

3. Handling

If defects can be seen in the materials, processing or performance of the device during the guarantee period, guarantee claims must be made immediately, or at the latest within a period of 2 weeks.

The authorised specialist shop that delivered the device is entitled to accept guarantee claims. Guarantee claims may also be made to the service centres named in our operating instructions. The product has to be sent without charge or presented together with the original purchase document that includes details of the purchase date and the name of the product. In order to claim for an extension to the guarantee, the guarantee certificate must be included.

The costs as well as the risk of loss or damage to the product in transit or by the centre that accepts the guarantee claims or who delivers the repaired product, are the responsibility of the customer.

4. Exclusion of guarantee

Guarantee claims cannot be considered

- for parts that are subject to wear and tear due to use or other natural wear and tear, as well as defects in the product that are a result of natural wear and tear, or wear and tear due to use. This includes in particular cables, valves, packaging, jets, cylinders, pistons, means-carrying housing components, filters, pipes, seals, rotors, stators, etc. Damage due to wear and tear that is caused in particular by sanded coating materials, such as dispersions, plaster, putty, adhesives, glazes, quartz foundation.
- in the event of errors in devices that are due to non-compliance with the operating instructions, unsuitable or unprofessional use, incorrect assembly and/or commissioning by the buyer or by a third party, or utilisation other than is intended, abnormal ambient conditions, unsuitable coating materials, unsuitable operating conditions, operation with the incorrect mains voltage supply/frequency, over-operation or defective servicing or care and/or cleaning.
- for errors in the device that have been caused by using accessory parts, additional components or spare parts that are not original Wagner parts.
- for products to which modifications or additions have been carried out.
- for products where the serial number has been removed or is illegible
- for products to which attempts at repairs have been carried out by unauthorised persons.
- for products with slight deviations from the target properties, which are negligible with regard to the value and usability of the device.
- for products that have been partially or fully taken apart.

5. Additional regulations.

The above guarantees apply exclusively to products that have been bought by authorised specialist shops in the EU, CIS, Australia and are used within the reference country.

If the check shows that the case is not a guarantee case, repairs are carried out at the expense of the buyer.

The above regulations manage the legal relationship to us conclusively. Additional claims, in particular for damages and losses of any type, which occur as a result of the product or its use, are excluded from the product liability act except with regard to the area of application.

Claims for liability for defects to the specialist trader remain unaffected.

German law applies to this guarantee. The contractual language is German. In the event that the meaning of the German and a foreign text of this guarantee deviate from one another, the meaning of the German text has priority.

J. Wagner GmbH

Division Professional Finishing
Otto Lilienthal Strasse 18
88677 Markdorf
Federal Republic of Germany



CE Konformitätserklärung

Hiermit erklären wir, daß die Bauart vom
Airlless Hochdruck-Spritzgerät,
benzinbetrieben

CE Declaration of conformity

Herewith we declare that the supplied
version of
Airlless high-pressure spraying unit, gas
powered

CE Déclaration de conformité

Par la présente, nous déclarons, que le
type de
Groupe de projection à haute pression, à
essence

CE Dichiarazione di conformità

Si dichiara che il modello
Impianto per la verniciatura a spruzzo ad
alta pressione Airlless, azionato a benzina

folgenden einschlägigen Bestimmungen
entspricht:

2006/42 EG

Angewendete harmonisierte Normen,
insbesondere:

complies with the following provisions
applying to it:

2006/42 EC

Applied harmonized standards, in
particular:

correspond aux dispositions pertinentes
suivantes:

2006/42 CE

Normes harmonisées utilisées,
notamment:

è conforme alle seguenti disposizioni
pertinenti:

2006/42 CE

Norme armonizzate applicate,
in particolare:

Angewendete nationale technische
Spezifikationen, insbesondere:

Applied national technical standards and
specifications, in particular:

Normes et specifications techniques
nationales qui ont été utilisées,
notamment:

Gebruikte nationale technische normen en
specifications, in het bijzonder:

DIN EN ISO 12100: 2011-03, DIN EN 1953:2011-7

BGR 500 /2/ Kapitel 2.29, 2.36

T. Wachs

J. Ullrich

Markdorf, 14.12.2012
Location, Date

Senior Vice President
Global Product Planning & Strategy

Hr. T. Jeltsch (Mr.)

Vice President Engineering

Hr. J. Ullrich (Mr.)
Dokumentationsverantwortlicher
Responsible person for documents
Responsabile della documentazione

Wagner-Nr. 2336497



J. Wagner GmbH Otto Lilienthal-Str. 18 D-88677 Markdorf



CE Konformitätserklärung

CE Declaration of conformity

CE Déclaration de conformité

CE Dichiarazione di conformità

Hiermit erklären wir, daß die Bauart vom
Airless Hochdruck-Spritzgerät

Herewith we declare that the supplied
version of
Airless high-pressure spraying unit

Par la présente, nous déclarons, que le
type de
Groupe de projection à haute pression

Si dichiara che il modello
Impianto per la verniciatura a spruzzo ad
alta pressione Airless

Wagner HeavyCoat

HC 950 1~ 230V/50HZ; HC 970 3~ 400V/50HZ; HC 950 SSP 1~ 230V/50HZ; HC 970 SSP 3~ 400V/50HZ

folgenden einschlägigen Bestimmungen
entspricht:

complies with the following provisions
applying to it:

correspond aux dispositions pertinentes
suivantes:

é conforme alle segenti disposizioni
pertinenti:

2006/42 EG

2006/42 EC

2006/42 CE

2006/42 CE

Angewendete harmonisierte Normen,
insbesondere:

Applied harmonized standards, in
particular:

Normes harmonisées utilisées,
notamment:

Norme armonizzate applicate,
in particolare:

DIN EN ISO 12100: 2011-03, DIN EN 1953: 2011-07, DIN EN 60204-1:2011-1,

DIN EN 61000-6-1:2007-10, DIN EN 61000-6-3:2012-11, DIN EN 61000-3-2 :2010-03, DIN EN 61000-3-3 :2009-06

Angewendete nationale technische
Spezifikationen, insbesondere:

Applied national technical standards and
specifications, in particular:

Gebruikte nationale technische normen en
specificaties, in het bijzonder:

BGR 500 /2/ Kapitel 2.29, 2.36

Markdorf, 14.12.2012
Location, Date

Signature

Vice President Engineering

Senior Vice President
Global Product Planning & Strategy

Hr. T. Jeltsch (Mr.)

Wagner-Nr. 2336498

Hr. J. Ulbrich (Mr.)
Dokumentationsverantwortlicher
Responsible person for documents
Responsabile de la documenta
Responsabile della documentazione

D

Entsorgungshinweis:

Gemäß der europäischen Richtlinie 2002/96/EG zur Entsorgung von Elektro-Altgeräten, und deren Umsetzung in nationales Recht, ist dieses Produkt nicht über den Hausmüll zu entsorgen, sondern muss der umweltgerechten Wiederverwertung zugeführt werden!

Ihr Wagner-Altgerät wird von uns, bzw. unseren Handelsvertretungen zurückgenommen und für Sie umweltgerecht entsorgt. Wenden Sie sich in diesem Fall an einen unserer Service-Stützpunkte, bzw. Handelsvertretungen oder direkt an uns.



GB

Note on disposal:

In observance of the European Directive 2002/96/EC on waste electrical and electronic equipment and implementation in accordance with national law, this product is not to be disposed of together with household waste material but must be recycled in an environmentally friendly way!

Wagner or one of our dealers will take back your used Wagner waste electrical or electronic equipment and will dispose of it for you in an environmentally friendly way. Please ask your local Wagner service centre or dealer for details or contact us direct.



Free Manuals Download Website

<http://myh66.com>

<http://usermanuals.us>

<http://www.somanuals.com>

<http://www.4manuals.cc>

<http://www.manual-lib.com>

<http://www.404manual.com>

<http://www.luxmanual.com>

<http://aubethermostatmanual.com>

Golf course search by state

<http://golfingnear.com>

Email search by domain

<http://emailbydomain.com>

Auto manuals search

<http://auto.somanuals.com>

TV manuals search

<http://tv.somanuals.com>