

**Limited Warranty**

For two years from the date of purchase, Wayne Water Systems ("Wayne") will repair or replace, at its option, for the original purchaser any part or parts of its Sump Pumps or Water Pumps ("Product") found upon examination by Wayne to be defective in materials or workmanship. Please call Wayne (800-237-0987) for instructions or see your dealer. Be prepared to provide the model and serial number when exercising this warranty. All transportation charges on Products or parts submitted for repair or replacement must be paid by purchaser.

This Limited Warranty does not cover Products which have been damaged as a result of accident, abuse, misuse, neglect, improper installation, improper maintenance, or failure to operate in accordance with Wayne's written instructions.

**THERE IS NO OTHER EXPRESS WARRANTY. IMPLIED WARRANTIES, INCLUDING THOSE OF MERCHANTABILITY AND FITNESS FOR A PARTICULAR PURPOSE, ARE LIMITED TO TWO YEARS FROM THE DATE OF PURCHASE. THIS IS THE EXCLUSIVE REMEDY AND ANY LIABILITY FOR ANY AND ALL INDIRECT OR CONSEQUENTIAL DAMAGES OR EXPENSES WHATSOEVER IS EXCLUDED.**

Some states do not allow limitations on how long an implied warranty lasts, or do not allow the exclusions or limitations of incidental or consequential damages, so the above limitations might not apply to you. This limited warranty gives you specific legal rights, and you may also have other legal rights which vary from state to state.

In no event, whether as a result of breach of contract warranty, tort (including negligence) or otherwise, shall Wayne or its suppliers be liable for any special, consequential, incidental or penal damages including, but not limited to loss of profit or revenues, loss of use of the products or any associated equipment, damage to associated equipment, cost of capital, cost of substitute products, facilities, services or replacement power, downtime costs, or claims of buyer's customers for such damages.

You **MUST** retain your purchase receipt along with this form. In the event you need to exercise a warranty claim, you **MUST** send a **copy** of the purchase receipt along with the material or correspondence. Please call Wayne (800-237-0987) for return authorization and instructions.

**DO NOT MAIL THIS FORM TO WAYNE.** Use this form only to maintain your records.

MODEL NO. \_\_\_\_\_ SERIAL NO. \_\_\_\_\_

INSTALLATION DATE \_\_\_\_\_

**ATTACH YOUR RECEIPT HERE**

Please completely read and save these instructions. Read carefully before attempting to assemble, install, operate or maintain the product described. Protect yourself and others by observing all safety information. Failure to comply with instructions could result in personal injury and/or property damage! Retain instructions for future reference.



**AC/DC Sump Pump System**

Record Serial Number here. (Serial Number is found on Pump Housing)

**Description**

The AC/DC Sump Pump System includes a submersible sump pump and a Power Supply/Battery Charger (PS/BC). Backup power is supplied by two 12 volt batteries (not included). The system is designed for home sump applications. When an electrical power outage occurs, the PS/BC automatically switches the sump pump to battery power so it will continue to pump water. Using LED's (Light Emitting Diodes), the PS/BC also alerts you to potential problems.

**Safety Guidelines**

This manual contains information that is very important to know and understand. This information is provided for SAFETY and to PREVENT EQUIPMENT PROBLEMS. To help recognize this information, observe the following symbols.

**⚠ DANGER** Danger indicates an imminently hazardous situation which, if not avoided, will result in death or serious injury.

**⚠ WARNING** Warning indicates a potentially hazardous situation which, if not avoided, could result in death or serious injury.

**⚠ CAUTION** Caution indicates a potentially hazardous situation which, if not avoided, may result in minor or moderate injury.

**⚠ NOTICE** Notice indicates important information, that if not followed, may cause damage to equipment.

**General Safety Information**

**⚠ DANGER** Do not use to pump flammable or explosive fluids such as gasoline, fuel oil, kerosene, etc. Do not use in a flammable and/or explosive atmosphere. Personal injury and/or property damage could result. Only use pump to pump clear water.

**⚠ NOTICE** This pump is not designed to handle salt water, brine, laundry discharge, water softener, sewage, graywater or any other application which may contain caustic chemicals and/or foreign materials. Pump damage could occur if used in these applications and will void warranty.

**⚠ WARNING** All wiring must be performed by a qualified electrician.

**⚠ DANGER** If the basement has water or moisture on the floor, do not walk on wet area until all power is turned off. If the shutoff box is in the basement, call an electrician. Remove pump and either repair or replace. Failure to follow this warning could result in fatal electrical shock.

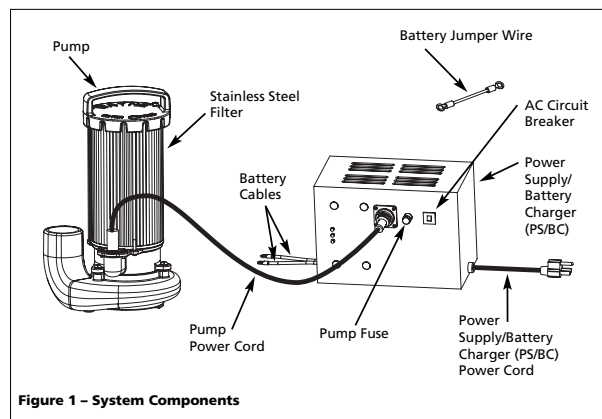

Figure 1 – System Components

**Pump Specifications**

Power supply requirements	.....	120V, 60 Hz
Motor	.....	Brushless Integral Processor
Normal water removal	.....	.36 GPM @ 10 Feet
Liquid temperature range	.....	40°F to 120°F
Circuit requirements	.....	.4 amps AC (min)
Pump Dimensions	.....	.11 1/2" high x 9 1/4" base
Pump starts at (factory set)	.....	.12" Water Level
Pump stops at (factory set)	.....	.6" Water Level

**Pump Construction**

Motor housing, volute, filter cap	.....	Cast Iron
Impeller	.....	Glass-filled Ryton®
Shaft	.....	.410 Stainless Steel
Discharge	.....	1 1/2" NPT
Float switch	.....	.2-position
Filter	.....	Stainless Steel

**REMINDER:** Keep your dated proof of purchase for warranty purposes! Attach it to this manual or file it for safekeeping.

## Pump Installation

**NOTICE** Installation may take several hours. Do not disable an existing sump pump until you have established an appropriate way to evacuate sump pit.

1. Install pump in a sump pit with minimum size as shown in Figure 2. Construct sump pit of tile, concrete, steel or plastic. If the sump pit already exists, disconnect power to existing pump and make certain pit is the correct size.
2. The sump pump should be located on a solid, level foundation. Do not place pump directly on clay, earth, gravel or a sandy surface. These surfaces contain small stones, gravel, sand, etc. that may clog or damage the pump and cause pump failure. Remove any silt or debris from the sump pit and surrounding area.

**AWARNING** Flood risk. If flexible discharge hose is temporarily used, make sure pump is secured in sump pit to prevent movement. Failure to secure pump could result in flooding and property damage.

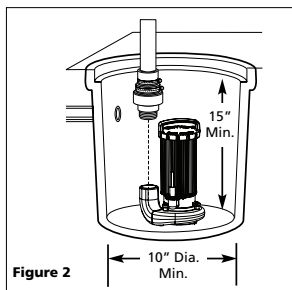

**NOTICE** Flexible discharge hose is intended for temporary use only. Rigid PVC or metal pipe is required for a permanent installation.

3. Thread check valve (not included) into pump body. Avoid stripping or cross threading. Do not use pipe joint sealant.
4. The pump has a 1-1/2" NPT discharge. If the existing piping is smaller, use an adapter. Smaller diameter piping will reduce the pump flow rate and decrease its performance. Do not reduce below 1 1/4".

5. Connect rigid pipe to rubber boot on check valve. Tighten hose clamps.

**AWARNING** Support pump and piping when assembling and after installation. Failure to do so could cause piping or check valve to break, pump to fail, etc., which could result in property damage and/or personal injury.

6. Protect electrical cord from sharp objects, hot surfaces, oil and chemicals. Avoid kinking the cord. Replace a damaged cord immediately.
7. A sump pit cover must be installed to prevent debris from clogging or damaging the pump.
8. Fill sump with at least 6 inches of water.

## Multiple pump systems

When installing more than one pump in a sump it will be necessary to decide if the AC/ DC Sump Pump will be installed as a primary or as a back up sump pump. The manufacturer recommends the AC/ DC Sump Pump be installed as a primary pump. A conventional AC powered electrical back up pump can be installed alongside as shown in Figure 3. You will need to raise the electrical back up pump by placing it on a brick, or by adjusting the float so that the electrical pump turns on above the level of the AC/ DC Sump Pump.

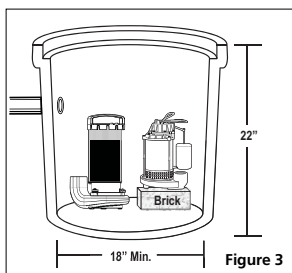

If the AC/ DC Sump Pump is to be used as a backup for an electrical primary pump it is important to maintain a minimum water level of 6 inches in the sump when measured from the bottom of the AC/ DC Sump Pump. The water is needed to allow the AC/ DC Sump Pump to go through its 24-hour testing cycle. You will need to adjust the off level of the Electrical Primary Pump to turn off at the minimum water level of 6 inches as shown in Figure 4.

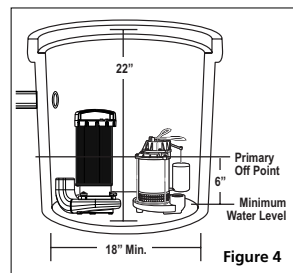

The on level of the Electrical Primary Pump must turn on before the 11 inch on point of the AC/ DC Sump Pump. Do not raise the AC/ DC Sump Pump above the level of the Electrical Primary Pump.

If it is necessary to have the primary and back up pumps discharge into a common line, check valves will be required on both pumps to eliminate back reticulating flow into the inactive pump.

## Battery Information

The system is designed to operate most efficiently with sealed lead acid (SLA) batteries at 24 volts. Two 12-volt 40-amp hour SLA batteries provide enough energy to pump more than 10,000 gallons of water from a basement. Deep cycle marine batteries can also be used.

Sealed lead acid batteries cost slightly more, but they can last longer. Wayne offers a 40 amp hour battery, 66900-

CHART 1 - STANDBY POWER PUMPING CAPACITY

Amp Hours Per Battery	Total Gallons Pumped*
40.0	11,000
80.0	22,000
120.0	33,000

\* Assumes the sump pump is lifting water 10'

## Troubleshooting Chart

Problem	Possible Cause(s)	Corrective Action
AC Power Indicator (red light) is not on	1. Power outage 2. Blown AC breaker 3. GFCI tripped 4. Low AC voltage	1. None 2. Push AC breaker to reset. If breaker trips again, do not reset. Have unit checked by qualified electrician 3. Reset GFCI 4. Have outlet checked by electrician
Alarm sounds - yellow light is on	1. Pump fuse may be blown 2. Pump impeller may be damaged	1. Replace pump fuse. Use Bussmann AGC10 or Littlefuse 312010 2. Remove impeller. Check for damage to bore or bearing
Alarm sounds - yellow light is on and red light is off	Low battery	Apply AC power or replace batteries
Green Light is off	1. Battery polarity is incorrect 2. Battery voltage too low	1. Recheck battery polarity 2. Replace batteries
Pump will not stop	1. Lower float stuck 2. Pump too low in sump	1. Remove filter and clean. Remove debris from float switch area 2. Place a brick under the pump
Pump will not start	1. Pump power cord 2. Upper float switch stuck 3. Impeller rotor jam	1. Check for proper installation of power cord into the PS/BC 2. Remove filter and clean. Remove debris from float switch area 3. Remove filter and clean. Remove debris from float switch area
Pump starts/stops too often	1. Backflow from discharge pipe 2. Pump too low in sump 3. Clogged pump filter	1. Install or replace check valve 2. Place a brick under the pump 3. Remove filter and clean
Pump operates but delivers little or no water	1. Blocked discharge pipe 2. Partially clogged pump filter 3. Broken thrust bearing	1. Check for restrictions in discharge line, flood is immanent. Shut off AC power before entering flooded area 2. Remove impeller, check for debris in inlet 3. Remove and inspect thrust bearing
"Click" inside PS/BC. An overload is indicated when you hear a distinct "click" from the DC circuit breaker internal to the PS/BC. A 3-5 minute cooling off period occurs before the PS/BC resets itself. If the overload condition still exists, the cycle will repeat. Regardless of what is causing the circuit breaker to cycle, unattended or routine operation in this manner could result in serious damage to the PS/BC and the battery.	1. Discharged battery 2. Shorted cell battery	1. If the battery is in otherwise good condition, it is normal for the circuit breaker to cycle ON and OFF several times before the battery recovers enough to allow a normal charge rate. If this happens on a regular basis, however, the batteries may be too large for the PS/BC and it could be damaged. Replace batteries 2. A battery in this condition may cause the breaker to cycle continuously. The battery will not accept a charge. Replace both batteries

## For Replacement Parts, call 1-800-237-0987

Please provide following information:

- Model number
- Serial number (if any)
- Part description and number as shown in parts list

Address parts correspondence to:

Wayne Water Systems  
100 Production Drive  
Harrison, OH 45030 U.S.A.

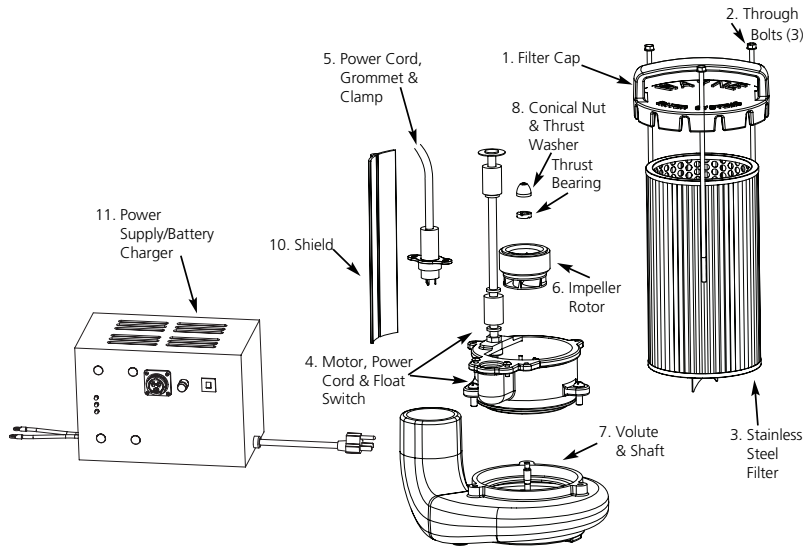

### Replacement Parts List

Ref. No.	Description	ISP40
1	Filter Cap	40020-001
2	Through Bolts	67048-001
3	Stainless Steel Filter	11024-001
4	Motor, Power Cord & Float Switch	66079-WYN1
5	Power Cord, Grommet & Clamp	66080-WYN1
6	Impeller Rotor	32085-002
7	Volute and Shaft	66081-WYN1
8	Conical Nut, Thrust Washer, Thrust Bearing	66082-WYN1
9	Jumper Wire *	31029-001
10	Shield	43005-001
11	Power Supply/Battery Charger	30215-001

\* Not Shown

## Battery Information (Continued)

WYN1, and a 75 amp hour battery, 66901-WYN1.

The oversize battery case (included) will accommodate two 12-volt SLA batteries or two 12-volt deep cycle marine batteries (up to a 27-frame size). Retain blue foam pad to support Wayne sealed lead-acid batteries. Use new, identical batteries (from the same manufacturer and of the same capacity). When batteries wear out replace them as a set. Chart 1 illustrates the expected performance with various battery combinations. Do not use batteries rated below 40 amp hours. Be certain that the area around the batteries is well ventilated. Before servicing the batteries, blow away gasses by waving a piece of cardboard near the batteries. Do not place batteries directly on concrete floor.

**⚠ DANGER** *Dangerous hydrogen gas can be released from batteries while charging. Sparks can ignite the gas in an enclosed space. Wear safety goggles when connecting batteries. Battery connections should be made in a well-ventilated area.*

**⚠ DANGER** *Working in the vicinity of lead acid batteries can be dangerous. Before making connections or servicing the batteries, read and follow instructions in all applicable instruction manuals. To reduce the risk of battery explosion, follow the instructions in this manual and those published by the battery manufacturer, as well as those of any other equipment used in the surrounding area.*

An assistant should be present or close enough to come to your aid in the event of an emergency. Have a reliable source of fresh water and soap nearby in case battery acid contacts clothing, skin or eyes.

Wear eye and clothing protection when working around lead acid batteries. Avoid touching your eyes when working around lead acid batteries.

**⚠ WARNING** *If battery acid contacts your eye(s), flush with cold running water for 10 minutes and seek immediate medical attention. If acid contacts your skin or clothing, wash immediately with soap and water.*

**⚠ WARNING** *Never smoke or allow a spark or flame in the vicinity of the battery.*

CHART 2 - PS/BC STATUS LIGHTS

LIGHT	ON WHEN	ACTION REQUIRED
Red	AC power is connected	None
Green	Battery connected	None
Yellow	Battery voltage is below 23.2 volts – buzzer sounds	Replace batteries – flooding is possible
	— OR —	
	Pump fuse blown – buzzer sounds	Replace fuse

**⚠ WARNING** *Avoid dropping metal tools on the battery posts because they may spark or short-circuit the system or battery, causing an explosion.*

### PS/BC Features

- Provides power to the pump
- Automatically charges and maintains the charge to the batteries
- Operates on 120-volt AC or 24-volt DC (two 12-volt batteries)
- Sounds alarm if fuse is blown or battery power is low
- The PS/BC can be left on the batteries indefinitely. Light Emitting Diodes (LEDs) keep you informed of the system's status (see Chart 2).

The Power Supply/Battery Charger is a 7 ampere, 24 volt automatic battery charger for conventional wet cell and gelled electrolyte type deep cycle lead-acid batteries. The PS/BC is designed for use with your Wayne Water System pump. DO NOT USE for any other purpose.

### PS/BC Installation

**NOTICE** *Use Power Supply/Battery Charger (PS/BC) indoors, in a well-ventilated area. Do not expose PS/BC to rain or snow. Do not use an extension cord. Do not disassemble PS/BC. Be sure PS/BC ventilation holes are unobstructed. If PS/BC is dropped or damaged, do not operate; return to manufacturer for service.*

**⚠ WARNING** *Risk of electrical shock! Use a GFCI (Ground Fault Circuit Interrupter) receptacle to reduce the risk of fatal electrical shock. Grounded receptacle must be rated for at least 5 amps.*

**⚠ WARNING** *Always disconnect AC power and remove pump fuse before connecting or disconnecting battery.*

1. Select a suitable position on the floor near the sump pit to place the battery case. Be certain that the PS/BC power cord will reach AC power, and that the sump pump power cord will reach the PS/BC. Make sure the battery case vent holes are unobstructed. Make no connections at this time.

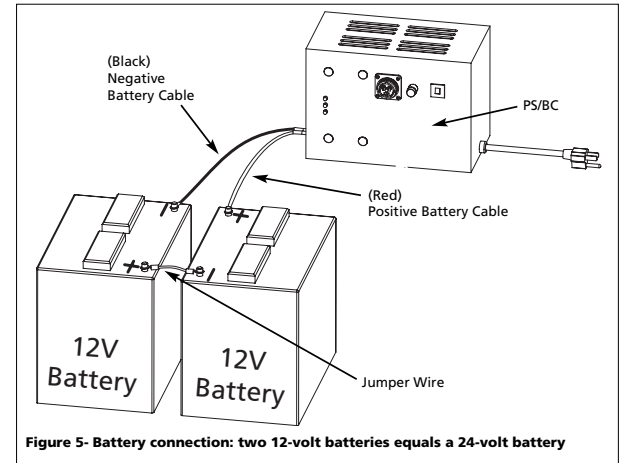

Figure 5- Battery connection: two 12-volt batteries equals a 24-volt battery

## PS/BC Installation (Continued)

2. Make sure the PS/BC power cord is disconnected.
3. Remove pump fuse and keep it in a safe place.
4. Place batteries side by side in battery case (see Figure 5).
5. Feed PS/BC battery cables through side access hole in battery case.
6. Carefully check battery polarity.
7. Attach jumper wire as shown in Figure 5 to achieve 24 volts.
8. Connect PS/BC battery cables to batteries as shown in Figure 5.
9. Tighten all battery connections securely.
10. Reinstall pump fuse. The green LED will light. If it does not light, make sure polarity of batteries and PS/BC cables are identical to Figure 5. The voltage at the PS/BC cables must be at least 18 volts or the PS/BC will not operate. Once the green LED is on, it will stay on unless the combined batteries' voltage falls below 7 volts.
11. Be sure pump is submerged in at least 6 inches of water.
12. Connect pump to PS/BC by inserting locking ring of pump power cord into opening on front of PS/BC – see Figure 1.

## Operation

**⚠ DANGER** Always disconnect the electrical supply before attempting to install, service, relocate or maintain the Power Supply/Battery Charger (PS/BC). Never handle PS/BC with wet hands or when standing on wet or damp surface or in water. Fatal electrical shock could occur.

**⚠ DANGER** Risk of electrical shock! The Power Supply/Battery Charger (PS/BC) is supplied with a grounding conductor and grounding plug. Use a grounded receptacle to reduce the risk of fatal electrical shock.

### PROPER GROUNDING OF AC POWER CORD

1. A ground fault circuit interrupter (GFCI) is required (See Figure 6).
2. The PS/BC is only for use on 120 volt (single-phase), 60 Hz service and is equipped with a 3-conductor cord and 3-prong, grounding type plug.

The plug **MUST** be plugged into a ground fault circuit interrupter outlet that is properly installed and grounded in accordance with all local codes and ordinances. If you ever feel even a slight shock from this or any electrical appliance, or equipment connected to it, STOP. Turn off electricity to outlet, and have it inspected by an electrician. You may have a dangerous, improperly wired outlet.

**IMPORTANT:** Never cut off the round grounding prong. Cutting the cord or plug will void the warranty and make the pump inoperable.

3. Insert the PS/BC power cord plug directly into the GFCI outlet (See Figure 6).

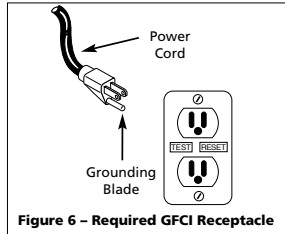

### TO TEST

**⚠ WARNING** Make certain there is at least 6 inches of water in the sump prior to connecting the pump to the PS/BC. Failure to do so may cause damage to pump.

1. Fill sump with water. The pump will start automatically when the water has filled the sump to a depth of approximately 12". The pump will stop when the water depth is approximately 6". The pump will recycle thereafter as required.
2. Do not operate the pump unless it is submerged in water. Dry running causes pump failure.
3. While the pump is draining the pit, verify that the discharge piping is carrying the water to a point several feet away from the foundation.
4. If pump discharge line is exposed to freezing temperature, the exposed line must be pitched to drain. Trapped water will freeze and damage the pump.

## Maintenance

**⚠ DANGER** Always disconnect the electrical supply before attempting to install, service, relocate or perform any maintenance. If the power source is out of sight, lock and tag in the open (off) position to prevent unexpected power application. Failure to do so could result in fatal electrical shock. Only qualified electricians should repair this unit. Improper repair could result in fatal electrical shock.

**NOTICE** When necessary, remove the filter for cleaning. If the pump is used in a dirty environment, frequent cleaning is necessary to assure adequate performance. Never sweep dirt or garbage into the sump pit.

**NOTICE** Do not operate the pump without the filter in place. The filter protects critical areas inside the pump from damage due to foreign objects. Operating the pump without the filter will void the warranty.

**NOTICE** Before disabling your pump, have ready an appropriate way to evacuate the sump pit should it refill with water while your pump is out of commission. Disconnect the power cord from the Power Supply/Battery Charger (PS/BC) to the pump. Simply unplugging the PS/BC from the AC power will not shut off the pump.

### FILTER, IMPELLER AND THRUST BEARING

1. Remove the pump from the sump pit. Loosen the three (3) through bolts that hold the filter cap in place.
2. Loosen the conical nut using an 1/8" Allen wrench.
3. Carefully remove thrust washer and thrust bearing, taking note of their orientation. The thrust washer can crack if it is dropped on a hard surface.
4. Using needlenose pliers, remove the impeller rotor. Take care not to damage the mounting face of the thrust washer with the pliers.
5. Thoroughly clean the filter with soapy water.

**NOTICE** Be careful not to damage the float switch, which is permanently installed in the motor housing. Attempting to remove the float switch will cause irreversible motor damage.

## Maintenance (Continued)

6. Remove any debris from impeller vanes and passages. Wash impeller in soapy water. Impeller magnet will crack if it is dropped on a hard surface.
7. Inspect thrust bearing. If its thickness is less than 0.15" or if it is cracked or damaged, replace.
8. Inspect the three impeller drives that engage with the thrust washer. Replace impeller if they are worn.
9. Inspect thrust washer. Replace if the thrust surface is worn.

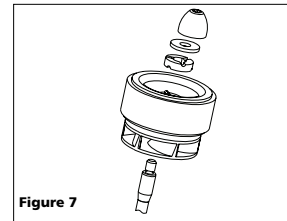

10. Reassemble parts in reverse order, as shown in Figure 7. For proper orientation of the thrust washer, refer to Figure 8. Do not overtighten the conical nut. Be careful not to damage the float when installing the filter cap.

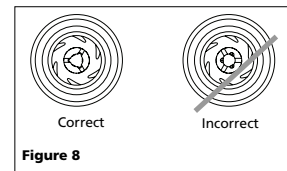

### BATTERIES

**⚠ DANGER** Dangerous hydrogen gas can be released from batteries while charging. Sparks can ignite the gas in an enclosed space. Wear safety goggles when connecting batteries. Battery connections should be made in a well-ventilated area.

**⚠ DANGER** Working in the vicinity of lead acid batteries can be dangerous. Before making connections or servicing the batteries, read and follow instructions in all applicable instruction manuals. To reduce the risk of battery explosion, follow the instructions in this manual and those published by the battery manufacturer, as well as those of any other equipment used in the surrounding area.

**⚠ WARNING** If battery acid contacts your eye(s), flush with cold running water for 10 minutes and seek immediate medical attention. If acid contacts your skin or clothing, wash immediately with soap and water.

**⚠ WARNING** Never smoke or allow a spark or flame in the vicinity of the battery.

**⚠ WARNING** Avoid dropping metal tools on the battery posts because they may spark or short-circuit the system or battery, causing an explosion.

Follow battery manufacturer's maintenance procedures and schedules. Be certain that the area around the batteries is well ventilated. Before servicing the batteries, blow away gasses by waving a piece of cardboard near the batteries.

**⚠ DANGER** Always disconnect the electrical supply before attempting to install, service, relocate or perform any maintenance.



1. Unplug the PS/BC.
2. For batteries with top caps that can be removed, the electrolyte level should be checked and filled to manufacturer's specifications. The charge for each cell should be checked with a hydrometer. A specific gravity of 1.265 indicates the battery is at full charge. If the specific gravity of any of the cells varies more than .050, the battery should be replaced.
3. Inspect the terminals and clamps for corrosion and tightness. Clean and tighten as required.
4. Check for proper pump operation.

### BATTERY TEST

1. Unplug AC power.
2. Fill sump with water. Pump will start automatically when water reaches edge of filter cap.
3. If low battery light (yellow LED) illuminates, batteries should be replaced. Replace batteries as a set. See Battery Information on Pages 2 and 3.

## Free Manuals Download Website

<http://myh66.com>

<http://usermanuals.us>

<http://www.somanuals.com>

<http://www.4manuals.cc>

<http://www.manual-lib.com>

<http://www.404manual.com>

<http://www.luxmanual.com>

<http://aubethermostatmanual.com>

Golf course search by state

<http://golfingnear.com>

Email search by domain

<http://emailbydomain.com>

Auto manuals search

<http://auto.somanuals.com>

TV manuals search

<http://tv.somanuals.com>