

Please read and save these instructions. Read carefully before attempting to assemble, install, operate or maintain the product described. Protect yourself and others by observing all safety information. Failure to comply with instructions could result in personal injury and/or property damage! Retain instructions for future reference.

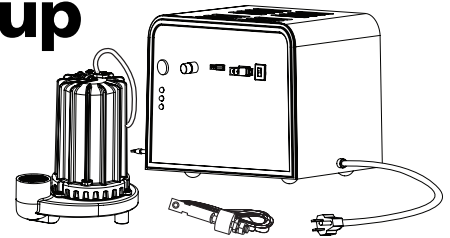

24-Volt Backup Sump Pump



Description

The ESP45 is a battery operated back-up sump pump. It does not replace a regular pump. It is designed to provide protection in the event household electrical power fails or main pump fails.

Unpacking

Inspect this unit before it is used. Occasionally, products are damaged during shipment. If the pump or components are damaged, return the unit to the place of purchase for replacement. Failure to do so could result in serious injury or death.

Safety Guidelines

This manual contains information that is very important to know and understand. This information is provided for SAFETY and to PREVENT EQUIPMENT PROBLEMS. To help recognize this information, observe the following symbols.

⚠ DANGER Danger indicates an imminently hazardous situation which, if not avoided, will result in death or serious injury.

⚠ WARNING Warning indicates a potentially hazardous situation which, if not avoided, could result in death or serious injury.

⚠ CAUTION Caution indicates a potentially hazardous situation which, if not avoided, may result in minor or moderate injury.

NOTICE Notice indicates important information, that if not followed, may cause damage to equipment.

General Safety Information

CALIFORNIA PROPOSITION 65

⚠ WARNING This product or its power cord may contain chemicals known to the State of California to cause cancer and birth defects or other reproductive harm. Wash hands after handling.

GENERAL SAFETY

⚠ DANGER
Do not use to pump flammable or explosive fluids such as gasoline, fuel oil, kerosene, etc. Do not use in a flammable and/or explosive atmosphere. Pump should only be used to pump clear water. Fatal injury and/or property damage could result.



⚠ DANGER
If the basement has water or moisture on the floor, do not walk on wet area until all power is turned off. If the shutoff box is in the basement, call an electrician. Remove pump and either repair or replace. Failure to follow this warning could result in fatal electrical shock.



⚠ WARNING All wiring must be performed by a qualified electrician.

⚠ WARNING Do not expose battery to sparks or flames as an explosion or fire could result.



⚠ WARNING Battery acid is corrosive. Avoid spilling on skin or clothing. Eye protection must be worn when handling the battery.



⚠ WARNING A check valve must be used on the primary sump pump discharge.

⚠ WARNING A ground fault circuit interrupter is required.

NOTICE This pump must only be used to pump clear water. This pump is not designed to handle effluent, salt water, brine, laundry discharge or any other application which may contain caustic chemicals and/or foreign materials. Pump damage may occur if used in these applications and will void warranty.

Pump Specifications

Power supply requirements	120V, 60 Hz
Motor	Permanent Magnet DC Motor
Normal water removal	2880 GPH @ 5 Feet @ 26V DC
Liquid temperature range	40°F to 120°F
Circuit requirements	5 amps AC (min)
Pump Dimensions	11 in. high x 8 3/4 in. base
Pump run time	15 Seconds

Pump Construction

Motor housing, volute, seal plate	Cast Iron
Impeller	Thermoplastic
Shaft	Stainless Steel
Discharge	1 1/2 in. NPT
Float switch	Reed Style

REMINDER: Keep your dated proof of purchase for warranty purposes! Attach it to this manual or file it for safekeeping.

Battery Information

The system is designed to operate most efficiently with sealed lead acid (SLA) batteries. Deep cycle marine batteries can also be used.

Sealed lead acid batteries cost slightly more, but they can last longer. Wayne offers a 40 amp hour battery WSB1240 and a 75 amp hour battery WSB1275. The oversize battery case (included) will accommodate two 12-volt SLA batteries or two 12-volt deep cycle marine batteries (up to a 27-frame size).

Retain blue foam pad to support Wayne sealed lead-acid batteries. Use new, identical batteries (from the same manufacturer and of the same capacity). When batteries wear out replace them as a set. Chart 1 illustrates the expected performance with various battery combinations. Do not use batteries rated below 40 amp hours.

Be certain that the area around the batteries is well ventilated. Before servicing the batteries, blow away gasses by waving a piece of cardboard near the batteries.

⚠ DANGER *Dangerous hydrogen gas can be released from batteries while charging. Sparks can ignite the gas in an enclosed space. Wear safety goggles when connecting batteries. Battery connections should be made in a well-ventilated area.*

⚠ DANGER *Working in the vicinity of lead acid batteries can be dangerous. Before making connections or servicing the batteries, read and follow instructions in all applicable instruction manuals. To reduce the risk of battery explosion, follow the instructions in this manual and those published by the battery manufacturer, as well as those of any other equipment used in the surrounding area.*

An assistant should be present or close enough to come to your aid in the event of an emergency. Have a reliable source of fresh water and soap nearby in case battery acid contacts clothing, skin or eyes.

Wear eye and clothing protection when working around lead acid batteries.

Avoid touching your eyes when working around lead acid batteries.

⚠ WARNING *If battery acid contacts your eye(s), flush with cold running water for 10 minutes and seek immediate medical attention. If acid contacts your skin or clothing, wash immediately with soap and water.*

⚠ WARNING *Never smoke or allow a spark or flame in the vicinity of the battery.*

⚠ WARNING *Avoid dropping metal tools on the battery posts because they may spark or short-circuit the system or battery, causing an explosion.*

PS/BC Features

POWER CIRCUITS:

- Power Supply/Battery Charger (PS/BC) monitors power availability and automatically switches to battery operation during power outage.
- Charger will run pump motor or charge batteries when plugged into AC power
- Automatically charges the batteries
- Operates on 120 VAC and 24 VDC (Using 2 batteries)
- The PS/BC can be left connected to the batteries indefinitely
- The PS/BC is designed for the Wayne Water Systems pump only, DO NOT Use For Any Other Purpose

CHART 1 - STANDBY POWER PUMPING CAPACITY

Amp Hours Per Battery	Total Gallons Pumped*
40.0	11,000
80.0	22,000
120.0	33,000

* Assumes the sump pump is lifting water 10'

SYSTEM WILL ALARM IF:

- You will hear a beeping alarm if pump motor is running
 - You will hear a continuous alarm if the pump fuse on front panel is blown
 - You will hear a continuous alarm if the battery voltage drops below 21.6
- NOTE:** The alarm must be on for the mute function to activate.

LIGHTS:

- Green Light indicates AC power is available
- Yellow Light indicates battery is connected correctly
- Red Light is on when battery voltage is low or if the pump motor fuse on the front panel is blown

PUMP:

- The pump will turn on when the float switch rises. The pump motor will keep running for 15 seconds after the float drops

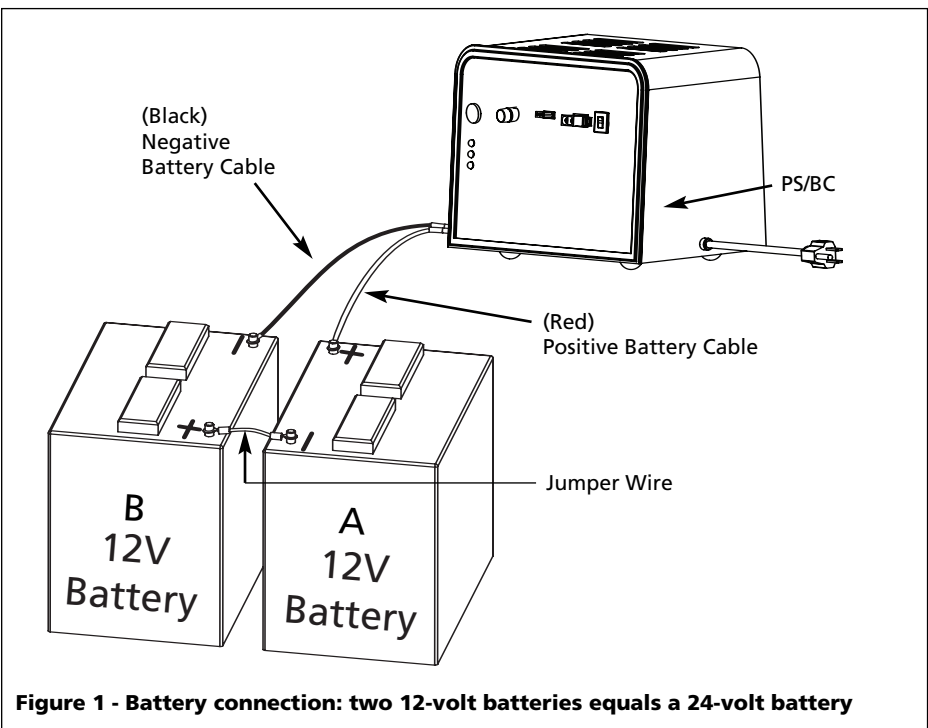

Figure 1 - Battery connection: two 12-volt batteries equals a 24-volt battery

Pump Installation

NOTICE

Installation of this unit may take several hours. Before disabling your main pump, have ready an appropriate means of evacuating the sump.

1. Turn power to main pump off.
2. Pump must be installed using 1/4" or 1/2" rigid PVC piping.

Pump Installation

The ESP45 can be installed as a back up system with a separate dedicated discharge line (Method 1), or tied into an existing sump pump line (Method 2).

⚠ DANGER

Unplug the existing AC pump. Failure to follow this warning could result in fatal electrical shock.

1. Verify that the existing AC pump is in good working order. If the AC pump is questionable, it is typically recommended that the unit be replaced with a 1/3 or 1/2 HP pump.
2. Remove any silt or accumulated debris from the sump pit and surrounding area.

Method 1 (Preferred)

1. Locate the ESP45 on a solid, level surface in the sump pit. Do not place the pump on a loose or sandy surface. Small stones or sand may damage the pump resulting in potential pump failure.
2. This pump has a 1/2" NPT discharge. If a 1/4" discharge pipe is desired, an adapter (not included) will be necessary. Smaller diameter piping will reduce pump flow, rate and performance.
3. Cut a 4' section of 1/4" or 1/2" diameter rigid PVC pipe. Cement 1/4" pipe to a threaded fitting. Cement 1/4" pipe into pipe coupling. Attach 1/4" pipe section to the ESP45 discharge adapter.
4. Screw on to pump discharge.

NOTICE

Be careful not to strip or cross thread plastic fittings or check valves. Flex hose is not recommended. Rigid PVC or metal pipe is required for a permanent installation.

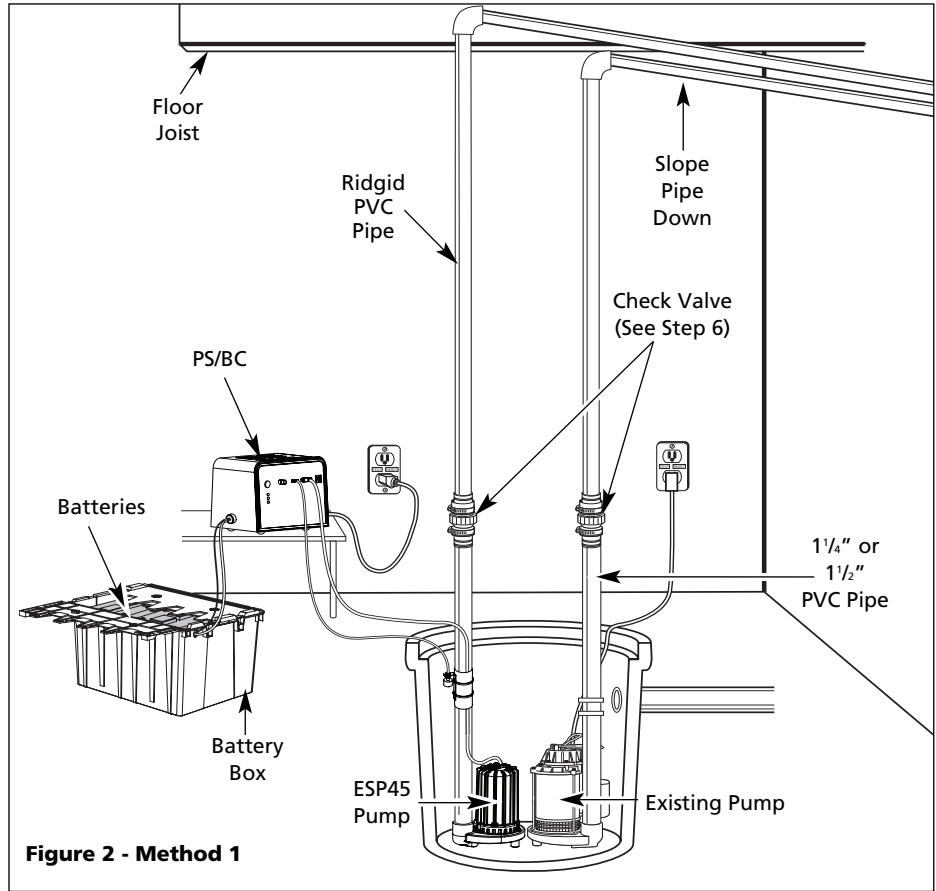

Figure 2 - Method 1

5. Place the pump with the 4' section of PVC pipe on a solid, level surface in the sump pit on an elevated surface.
6. Attach a rubber check valve (sold separately) to the top of the discharge pipe. This will allow the pump or check valve to be removed easily for servicing.
7. Check valve is required for effective operation of system.

NOTE: Check valves can be placed directly in the pump discharge if desired. However, for ease of disassembly, it is recommended that check valves be placed above the sump as shown in Figure 2.

The remainder of the discharge pipe installation will vary depending on individual circumstances. Using sound plumbing practices, route the discharge pipe to an exterior wall by the shortest path. Keep turns to a minimum because they reduce flow output of the pump. The pipe that exits the building structure should be

sloped downward so that water will not freeze in the pipe.

When installing the separate discharge pipe, drill through the outside wall with appropriate drilling equipment. Seal the hole to prevent water from entering.

Method 2

If a separate, dedicated discharge is not possible as in Method 1, the ESP45 pump can be tied in to the AC-operated pump's discharge pipe by installing a "Y" connector. Two check valves will be required.

1. Locate the ESP45 on a solid, level surface in the sump pit. Do not place the pump on a loose or sandy surface. Small stones or sand may damage the pump resulting in potential pump failure.
2. This pump has a 1/2" NPT discharge. If a 1/4" discharge pipe is desired, an adapter (not included) will be necessary. Smaller diameter piping will reduce pump flow, rate and performance.

Pump Installation (Continued)

3. A check valve will be required in the discharge line of **BOTH** the Main AC pump and the ESP45 pump to prevent recirculation of water into the sump pit. System will not function without two check valves.
4. Cut a 4' section of 1 1/4" or 1 1/2" diameter rigid PVC pipe. Cement 1 1/2" pipe to a threaded fitting. Cement 1 1/4" pipe into pipe coupling. Attach 1 1/4" pipe section to the ESP45 discharge adapter.
5. Screw on to pump discharge.

NOTICE *Be careful not to strip or cross thread plastic fittings or check valves. Flex hose is not recommended. Rigid PVC or metal pipe is required for a permanent installation.*

6. Place the pump with the 4' section of PVC pipe on the sump floor or on an elevated surface if required.
7. Attach a rubber check valve (sold separately) to the top of the discharge pipe. This will allow the pump or check valve to be removed easily for servicing.
8. Duplicate the discharge piping arrangement for the primary AC pump if the existing discharge line has to be adjusted to accommodate a second pump.
9. Glue a 45° elbow to the short pipe on the ESP45 pump. Glue a "Y" adapter to the short pipe on the existing pump, as shown in illustration for Method 2.
10. Glue a short piece of PVC pipe between the 45° elbow and the "Y".

NOTE: Check valves can be placed directly in the pump discharge if desired. However, for ease of disassembly, it is recommended that check valves be placed above the sump as shown in Figure 3.

The remainder of the discharge pipe installation will vary depending on individual circumstances. Using sound plumbing practices, route the discharge pipe to an exterior wall by the shortest distance.

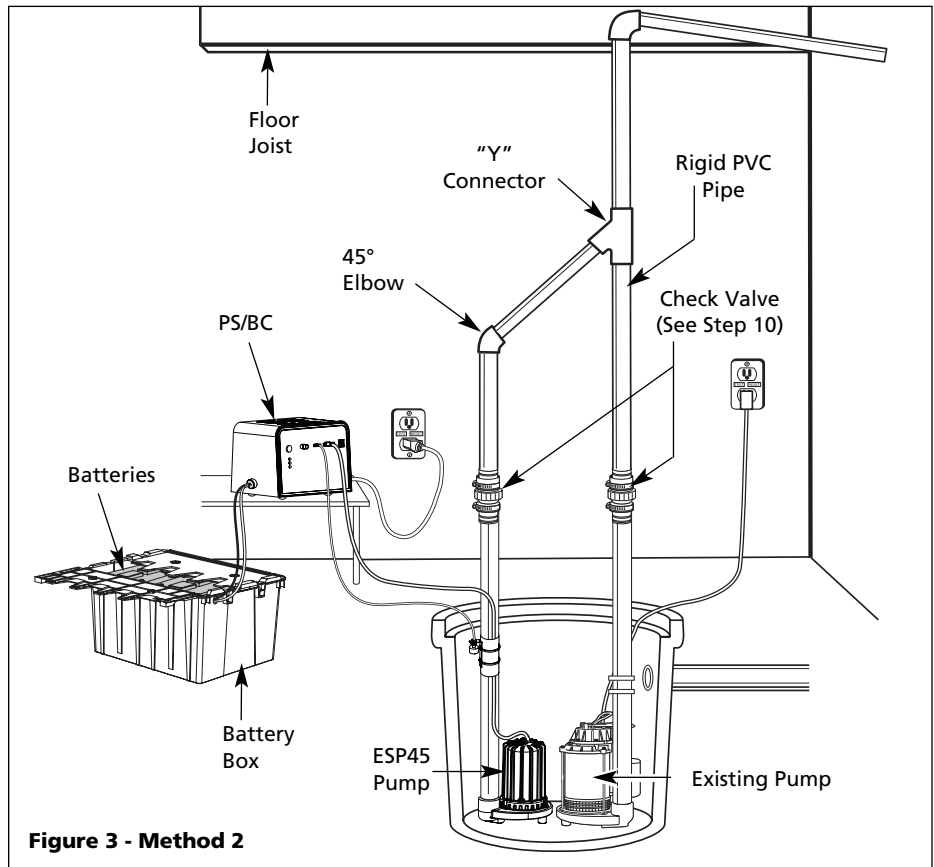

Figure 3 - Method 2

Methods 1 and 2

Install float switch at least 10"-12" above bottom of sump pit so that backup unit turns on only when the water level is higher than the normal "on" level for main pump. Use the hose clamps provided to secure the switch to the discharge pipe. Make sure power wires and hose clamp ends do not interfere with float switch, pump inlet, or main pump operation. Backup pump must not be allowed to run dry.

PS/BC Installation

NOTICE *Use Power Supply/ Battery Charger (PS/BC) indoors, in a well-ventilated area. Do not expose PS/BC to rain or snow. Do not use an extension cord. Do not disassemble PS/BC. Be sure PS/BC ventilation holes are unobstructed. If PS/BC is dropped or damaged, do not operate; return to manufacturer for service.*

WARNING *Risk of electrical shock! Use a GFCI (Ground Fault Circuit Interrupter) receptacle to reduce the risk of fatal electrical shock. Grounded receptacle must be rated for at least 5 amps.*

WARNING *Always disconnect AC power and remove pump fuse before connecting or disconnecting battery.*

1. Select a suitable position on the floor near the sump pit to place the battery case. Be certain that the PS/BC power cord will reach AC power, and that the sump pump power cord will reach the PS/BC. Make sure the battery case vent holes are unobstructed.

ELEVATE PS/BC BY MOUNTING ON WALL OR SETTING ON A SHELF. SLOTS IN THE BACK SIDE OF PS/BC ARE AVAILABLE FOR WALL MOUNTING.

Control Box Installation

CAUTION *If cables are reversed, damage to the PS/BC or battery could result, and warranty will be void.*

Dangerous hydrogen gas can be released from batteries while charging. Sparks can ignite the gas in an enclosed space. Wear safety goggles when connecting batteries. Battery connections should be made in a well-ventilated area.

PS/BC Installation (Continued)

- Place battery box within six feet of the sump and a 115 VAC separately fused outlet. The outlet must be protected by a ground fault circuit interrupter (GFCI). The area must also be clean, dry and well-ventilated.
- Wave cardboard over batteries to blow away any gas that may be present.
- Connect jumper wire between batteries as shown on Figure 1.
- Connect power wires from PS/BC to battery terminals as shown in Figure 1. Connect the red wire to the unconnected positive terminal of battery A and then connect the black wire to the unconnected negative terminal of battery B. The yellow light should now be on.
- Plug the pump and then the float into the PS/BC. The connections are marked.
- Test pump operation by filling the sump with water while the main pump is unplugged. If the pump operates properly, plug the PS/BC into the GFCI protected outlet to begin charging the battery.

NOTE: Protect electrical cord from sharp objects, hot surfaces, oil and chemicals. Avoid kinking the cord and replace damaged components immediately.

Operation

⚠ DANGER

Always disconnect the power source before attempting to install, service, relocate or maintain the pump. Never touch sump pump, pump motor, water or discharge piping when pump is connected to electrical power. Never handle a pump or pump motor with wet hands or when standing on wet or damp surface or in water. Fatal electrical shock could occur.



⚠ DANGER

Risk of electrical shock! Use a GFCI receptacle to reduce the risk of fatal electrical shock. Cutting the cord or plug will void the warranty and make the pump inoperable.



CHART 2 - PS/BC STATUS LIGHTS

LIGHT	ON WHEN	ACTION REQUIRED
Red	Low Voltage or Blown Fuse	Check Fuse or Replace Batteries
Yellow	Battery OK	None
Green	AC power on	None

- After installation, the backup pump will start when the water level rises above the depth that the primary pump should start.
- The PS/BC has a DC charger designed to shorten the recharging time of your battery, and to prevent overcharging. In addition, the control box has a time delay which keeps the pump from repeated, short cycles when it shuts off. This time delay feature will allow the pump to run 15 seconds after the switch reaches the off position.

⚠ DANGER Working in the vicinity of lead acid batteries can be dangerous. Before making connections or servicing the batteries, read and follow instructions in all applicable instruction manuals. To reduce the risk of battery explosion, follow the instructions in this manual and those published by the battery manufacturer, as well as those of any other equipment used in the surrounding area.

⚠ WARNING

If battery acid contacts your eye(s), flush with cold running water for 10 minutes and seek immediate medical attention. If acid contacts your skin or clothing, wash immediately with soap and water.

⚠ WARNING

Never smoke or allow a spark or flame in the vicinity of the battery.

⚠ WARNING

Avoid dropping metal tools on the battery posts because they may spark or short-circuit the system or battery, causing an explosion.

Follow battery manufacturer's maintenance procedures and schedules. Be certain that the area around the batteries is well ventilated. Before servicing the batteries, blow away gasses by waving a piece of cardboard near the batteries.

- Unplug the PS/BC.
- For batteries with top caps that can be removed, the electrolyte level should be checked and filled to manufacturer's specifications. The charge for each cell should be checked with a hydrometer. A specific gravity of 1.265 indicates the battery is at full charge. If the specific gravity of any of the cells varies more than .050, the battery should be replaced.

NOTE: An inexpensive hydrometer can be purchased at an automotive parts dealer.

Maintenance

⚠ DANGER

Unplug main AC pump and the charger. Risk of electrical shock!



⚠ DANGER

Always disconnect the electrical supply before attempting to install, service, relocate or per-form any maintenance. If the power source is out of sight, lock and tag in the open (off) position to prevent unexpected power application. Failure to do so could result in fatal electrical shock. Only qualified electricians should repair this unit. Improper repair could result in fatal electrical shock.



NOTICE

Once a month, check the condition of the battery. In order to review the battery condition, follow the steps that are listed below:

BATTERIES

⚠ DANGER

Dangerous hydrogen gas can be released from batteries while charging. Sparks can ignite the gas in an enclosed space. Wear safety goggles when connecting batteries. Battery connections should be made in a well-ventilated area.

Maintenance (Continued)

3. Inspect the terminals and clamps for corrosion and tightness. Clean and tighten as required.
4. Unplug the main pump and fill sump with water until back up pump turns on. Repeat process two times to be sure pump is operating normally.
5. If pump operates normally, plug PS/BC into wall outlet, turn on main pump. If pump fails to operate normally, see Troubleshooting guide and correct problem. Repeat step 5.

Troubleshooting Chart

Symptom	Possible Cause(s)	Corrective Action
Pump won't run	<ol style="list-style-type: none"> 1. Connections not secure 2. Low or defective battery 3. Float switch stuck 4. Defective or blown fuse 	<ol style="list-style-type: none"> 1. Check all connections 2. Check battery and replace if low or defective 3. Make sure nothing is interfering with operation of switch 4. Check internal fuse located on the PS/BC. Pull the charger from the wall outlet and remove. If the fuse is blown, replace it with an automotive type fuse of the same amp ratio.
Motor hums but pump won't run	<ol style="list-style-type: none"> 1. Defective battery 2. Impeller is locked 	<ol style="list-style-type: none"> 1. Check battery and replace if low or defective 2. Unplug pump, volute, and check to see if impeller is free to turn. If impeller is locked, remove the obstruction. Reassemble pump and reconnect
Pump runs but pumps very little or no water	<ol style="list-style-type: none"> 1. Check valve missing or improperly installed 2. Obstruction in discharge pipe or pump inlet 3. Discharge pipe length and/or height exceeds capacity of pump 4. Low or defective battery 	<ol style="list-style-type: none"> 1. Check to make sure check valves installed between primary pump discharge and Backup Sump Pump are functioning properly 2. Check for obstruction and clear if necessary 3. If discharge is too high, a separate line may be required with a lower discharge height 4. Check battery and replace if low or defective
Pump cycles too frequently	<ol style="list-style-type: none"> 1. Check valve problem 	<ol style="list-style-type: none"> 1. Check to make sure check valves installed between primary pump discharge and Backup Sump Pump are functioning properly
No yellow light	<ol style="list-style-type: none"> 1. Battery connection problem 	<ol style="list-style-type: none"> 1. Verify battery connection is correct
Red light is on with alarm	<ol style="list-style-type: none"> 1. Blown pump fuse 2. Low battery voltage 	<ol style="list-style-type: none"> 1. Check fuse and replace with a fuse of same rating and size 2. Check battery voltage. PS/BC will not charge batteries with a combined voltage of 21.6 VDC or less

For Replacement Parts, call 1-800-237-0987

Please provide following information:

- Model number
- Serial number (if any)
- Part descriptions and number as shown in parts list

Address parts correspondence to:

Wayne Water Systems
 101 Production Drive
 Harrison, OH 45030 U.S.A.

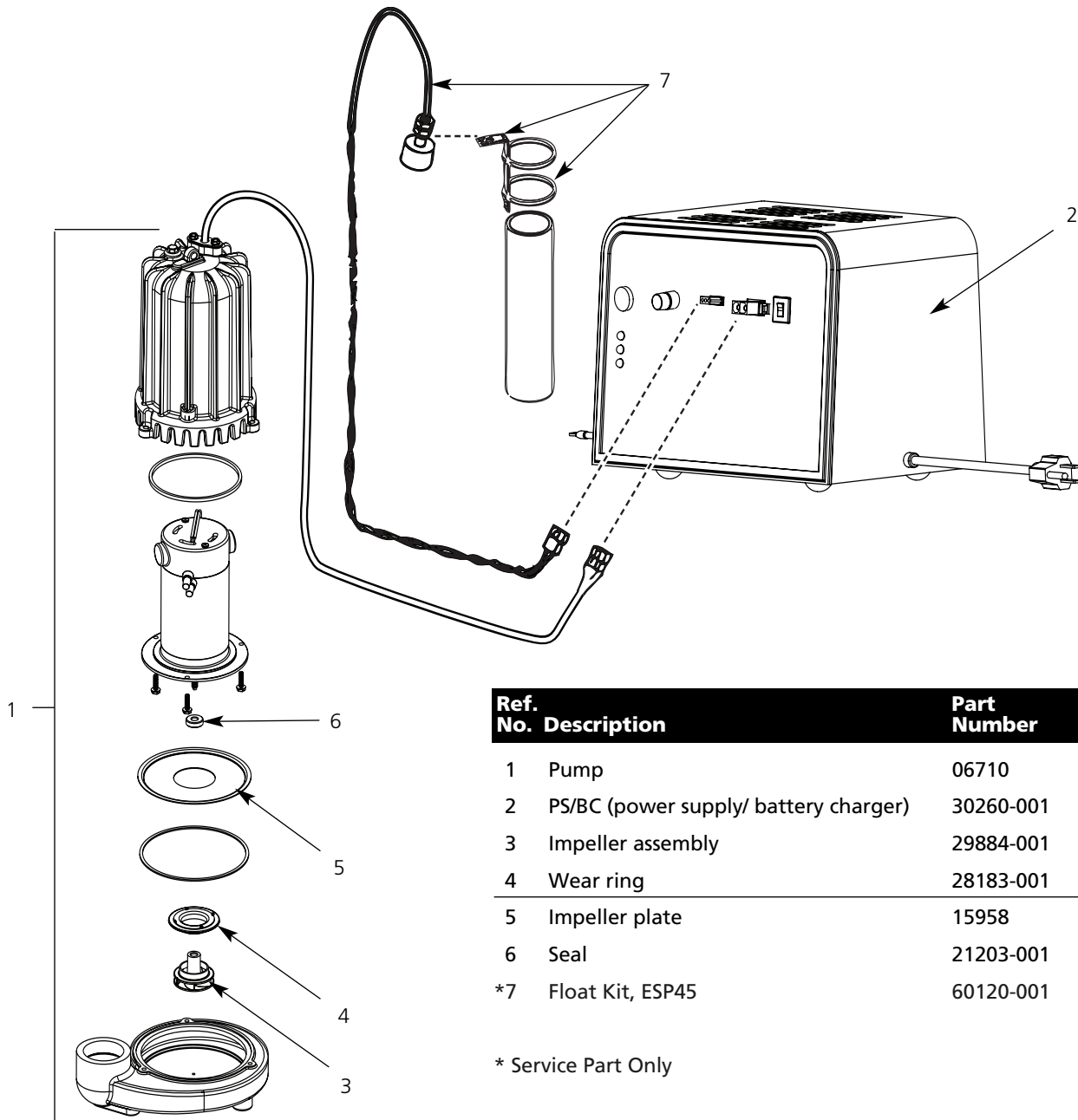

Ref. No.	Description	Part Number	Qty.
1	Pump	06710	1
2	PS/BC (power supply/ battery charger)	30260-001	1
3	Impeller assembly	29884-001	1
4	Wear ring	28183-001	1
5	Impeller plate	15958	1
6	Seal	21203-001	1
*7	Float Kit, ESP45	60120-001	1

* Service Part Only

Limited Warranty

For three years from the date of purchase, Wayne Water Systems ("Wayne") will repair or replace, at its option, for the original purchaser any part or parts of its Sump Pumps or Water Pumps ("Product") found upon examination by Wayne to be defective in materials or workmanship. Please call Wayne (800-237-0987) for instructions or see your dealer. Be prepared to provide the model and serial number when exercising this warranty. All transportation charges on Products or parts submitted for repair or replacement must be paid by purchaser.

This Limited Warranty does not cover Products which have been damaged as a result of accident, abuse, misuse, neglect, improper installation, improper maintenance, or failure to operate in accordance with Wayne's written instructions.

THERE IS NO OTHER EXPRESS WARRANTY. IMPLIED WARRANTIES, INCLUDING THOSE OF MERCHANTABILITY AND FITNESS FOR A PARTICULAR PURPOSE, ARE LIMITED TO THREE YEARS FROM THE DATE OF PURCHASE. THIS IS THE EXCLUSIVE REMEDY AND ANY LIABILITY FOR ANY AND ALL INDIRECT OR CONSEQUENTIAL DAMAGES OR EXPENSES WHATSOEVER IS EXCLUDED.

Some states do not allow limitations on how long an implied warranty lasts, or do not allow the exclusions or limitations of incidental or consequential damages, so the above limitations might not apply to you. This limited warranty gives you specific legal rights, and you may also have other legal rights which vary from state to state.

In no event, whether as a result of breach of contract warranty, tort (including negligence) or otherwise, shall Wayne or its suppliers be liable for any special, consequential, incidental or penal damages including, but not limited to loss of profit or revenues, loss of use of the products or any associated equipment, damage to associated equipment, cost of capital, cost of substitute products, facilities, services or replacement power, downtime costs, or claims of buyer's customers for such damages.

You **MUST** retain your purchase receipt along with this form. In the event you need to exercise a warranty claim, you **MUST** send a **copy** of the purchase receipt along with the material or correspondence. Please call Wayne (800-237-0987) for return authorization and instructions.

DO NOT MAIL THIS FORM TO WAYNE. Use this form only to maintain your records.

MODEL NO. _____ SERIAL NO. _____ INSTALLATION DATE _____

ATTACH YOUR RECEIPT HERE

Free Manuals Download Website

<http://myh66.com>

<http://usermanuals.us>

<http://www.somanuals.com>

<http://www.4manuals.cc>

<http://www.manual-lib.com>

<http://www.404manual.com>

<http://www.luxmanual.com>

<http://aubethermostatmanual.com>

Golf course search by state

<http://golfingnear.com>

Email search by domain

<http://emailbydomain.com>

Auto manuals search

<http://auto.somanuals.com>

TV manuals search

<http://tv.somanuals.com>