

MASTER
DO NOT
MAIL

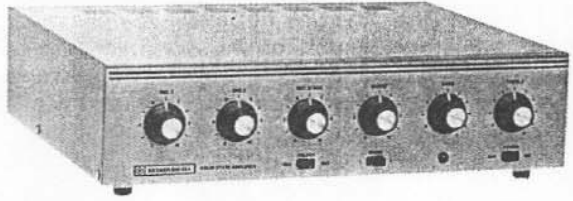

OPERATING INSTI



MODEL 800-40 AMPLIFIER

WARNING: TO PREVENT FIRE OR SHOCK HAZARD, DO NOT EXPOSE THIS AMPLIFIER TO RAIN OR MOISTURE.

DESCRIPTION:

The Raymer Model 800-40 is a multipurpose monaural 40 Watt RMS, all silicon solid state amplifier. It is designed for dependable continuous operation in background music, public address, paging, and sound reinforcement systems. The amplifier has provisions for mixing four inputs: three microphone inputs and one music input or two microphone inputs, one music input and one auxiliary input. Additional provision is made for a choice of one of two separate sources to be connected to the music input. Selector switches are provided to match each microphone input for either high or low impedance and will match a ceramic or crystal phono cartridge, a tuner, or other auxiliary equipment. The Model 800-40 has separate bass and treble controls, which may be used to compensate for room and speaker characteristics.

The amplifier also features an electronic Music Mute (Precedence) circuit in place of a relay to quickly fade out the music while paging; after the page, the music is smoothly restored.

The speaker outputs of the amplifier are for 4 or 8 ohms; or 25 or 70 volt, balanced or unbalanced lines. A preamp input/output jack is provided for connecting two or more amplifiers or receivers together so that they may be operated simultaneously to deliver a total power in multiples of 40 watts to a single speaker line. This feature applies only to units with "-40" model identification.

The amplifier is protected by a circuit breaker which prevents possible damage that might be caused by accidental shorts or overloads.

UNPACKING

The unit is to be removed carefully from the carton and inspected for any possible damage in transit. If there is any evidence of any damage which might have occurred in shipment, immediately notify your supplier, or the transportation company which delivered it. Claims for damage sustained in transit must be made

upon the carrier. Save all packing material for inspection by the claim agent who will furnish you with the proper forms and will also give you the necessary instructions for filing a claim.

INSTALLATION:

The Raymer Model 800-40 has ample vents for normal ventilation; however it should be placed so as to permit free air flow around the unit. DO NOT PLACE ANY OBJECT ON TOP OF THE COVER OR IN ANY WAY BLOCK THE AIR FLOW OF THE VENTS. DO NOT STORE OR OPERATE THE AMPLIFIER IN AREAS WHERE THE TEMPERATURE EXCEEDS 140 degrees F.

The amplifier may be mounted in a 5 1/4" vertical space in a rack, using the Raymer Model RPK-2 rack mounting kit.

This unit has an AC line cord with a 3 prong plug. The line cord should be plugged into a 3 wire grounded 105 to 120 volt 60Hz AC outlet. This will also ground the receiver.

The AC receptacle on the rear panel is a 3 wire grounded outlet which can supply power to accessory or auxiliary equipment. Any auxiliary equipment connected to this AC receptacle is controlled by the POWER on-off switch so that turning off the power on the unit turns off all equipment.

CONNECTIONS

All connections are made on the rear panel of the unit.

INPUT CONNECTIONS

All patch cords and input leads other than Music Mute must be shielded cables. The Music Mute leads do not have to be shielded. When output leads are run near an unshielded microphone input plug, or when run together with the microphone precedence leads, a supersonic oscillation may occur. When this does occur, it will appear as a distortion in the amplifier output, and oftentimes will cause the circuit breaker to "trip."

IN THE EVENT THAT THE CIRCUIT BREAKER CONTINUES TO TRIP, DO NOT ATTEMPT TO DEFEAT THE FUNCTION OF THE CIRCUIT BREAKER. HAVE THE TROUBLE INVESTIGATED BY A QUALIFIED SERVICE TECHNICIAN OR RETURN THE UNIT TO THE FACTORY.

PREAMP INPUT/OUTPUT

The preamp in/out jack may be used as an input for signaling, or as an output for an external amplifier, or as an interlock for parallel amplifier operation.

If it is desirable to add a signaling annunciator or alarm to the music and page system, a Raymer Model TGSP-4 Tone Generator may be connected to the amplifier. The output of the TGSP-4 should be connected to the preamp in/out jack. By connecting in this fashion the tone or alarm is unaffected by any of the front panel controls.

Two or more Raymer 40 watt amplifiers or receivers may be connected in parallel to deliver a total output in multitudes of 40 watts to one single speaker line. The units connected together for parallel operation must all have a "-40" model identification.

To operate these units into a single speaker line requires that the outputs be connected either in series or in parallel. In order to be sure that each of these units is driving the line equally, the inputs of each power stage must be connected in parallel. To do this, connect the preamp in/out jacks of the units together by means of a jumper cable with phono plugs at each end.

The output terminals of the 40 watt units have been phased at the factory so that each terminal is in phase with the corresponding terminal of any other 40 watt unit. To connect the outputs in series or parallel the terminals should be wired as shown in Figure 2.

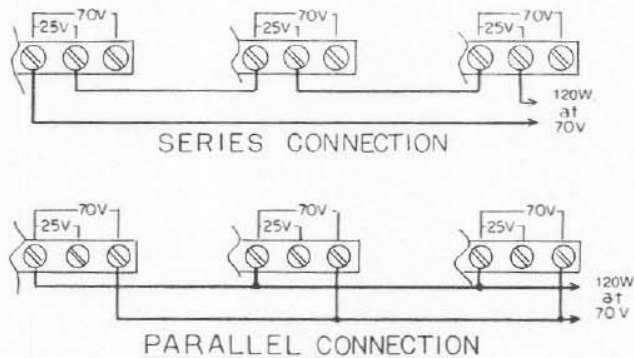

FIGURE 2: OUTPUT CONNECTIONS FOR PARALLEL OR SERIES OPERATION.

WHEN CONNECTING THE OUTPUTS IN SERIES, MAKE CERTAIN THAT THERE IS NO JUMPER CONNECTION BETWEEN COM AND GND ON THE SCREW TERMINAL BOARD.

WARRANTY

This unit has been very carefully inspected and is warranted to be free from defects in material and workmanship under normal use and service for a period of one year from date of sale to the original purchaser. This Warranty does not extend to any unit which has been subject to abuse, misuse, neglect, accident, improper installation, or alterations. The obligation of Cetec Trutone under this Warranty is limited to the repair of any defect in material or workmanship and/or the replacement of any defective part, provided the unit is returned to Cetec Trutone transportation paid within the year.

It is recommended that any unit on which service is required be processed through your distributor or installation company wherever possible.

This Warranty is expressly in lieu of all other Warranties, expressed or implied, and of all other obligations or liabilities on our part. We neither assume nor authorize any other person to assume for us any other liability in connection with the products manufactured by Cetec Trutone.

INPUTS

The Microphone input jacks are for an unbalanced line only. If it is necessary to use a balanced input, an outboard matching transformer such as Raymer Model LMT-150 must be used. If the signal source is a telephone line or a 500 ohm input, the connection can be made to the amplifier by means of a Raymer Telephone Matching Adaptor TM-2. The switch alongside each microphone input selects the proper input impedance. The Hi-Z position will match either crystal or high impedance dynamic microphones; the Lo-Z position will match microphones in the 150 to 500 ohm range.

If it is desirable to fade out the music while paging, a "dispatcher" type of microphone with an auxiliary switch having a pair of normally open contacts should be used. The microphone is to be connected as shown in Figure 1.

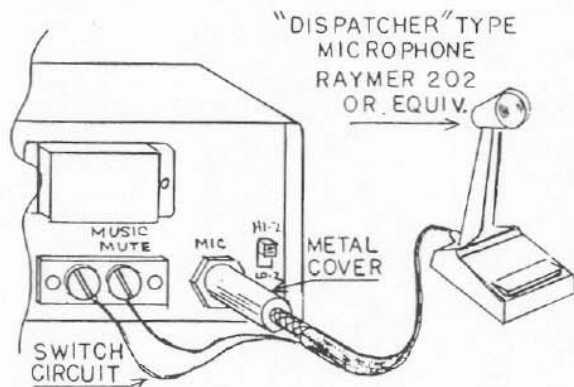

FIGURE 1.

TYPICAL CONNECTION FOR A SINGLE MICROPHONE. FOR MORE THAN ONE MICROPHONE, CONNECT THE SWITCH CIRCUITS IN PARALLEL.

CAUTION

To avoid possible supersonic oscillation which might result in damage to the unit, it is mandatory that a shielded (metal cover) microphone plug be used.

The MUSIC input is high impedance with a sensitivity of one-half volt and will accommodate the output of a ceramic phono cartridge or the output from any pre-amplifier such as tape, phono, etc. If the source into the MUSIC input is from leased telephone lines, a Raymer TM-2 telephone adaptor is required to match the telephone lines to the input.

The music channel has two input jacks for the selection of a desired signal source. This selection is controlled by a slide switch directly below the music control.

The Aux input is high impedance and is identical to the MUSIC input. The Aux input may be used in place of the MICROPHONE 3 input by means of a selector switch located directly below the MIC 3/AUX control.

OUTPUT CONNECTIONS

The speaker(s) or line matching transformers are connected to the screw terminal board located on the rear panel. For short distances any ordinary insulated wire, such as parallel lamp cord, may be used.

Long lines have an appreciable resistance with resultant power loss. The use of parallel matching transformers on either 25 volt or 70 volt lines is recommended for long distances. In all cases, it is advisable to run as heavy a wire as possible consistent with the requirements. To avoid inducing hum in the system, do not parallel speaker cables with any AC line power cables.

70 volt distribution systems often require the speaker lines to be run in conduit. To determine whether they should be run in conduit check with local city codes for 70 volt system requirements.

The 4 OHM or 8 OHM output is used when connecting directly to the speaker voice coils. When a speaker with an impedance of 8 ohms is connected to the amplifier, use the terminals on the amplifier marked GND and 8 Ω . For a 4 ohm speaker or two 8 ohm speakers in parallel, use GND and 4 Ω .

The 25 VOLT or 70 VOLT output is used when connecting to speakers which have line matching transformers. Connecting to the 25 volt or 70 volt tap on the unit permits the use of a number of speakers each with its own corresponding line matching transformer, thereby eliminating the necessity of calculating impedances. The tap on the line matching transformer is selected to give the power desired for each speaker. The total of all the power settings should be no greater than the amplifier output rating. If the speaker uses a 25 or 70 volt line transformer, connect the speaker transformer to the terminals marked COM and 25V (or 70V) according to the line desired. For an unbalanced line connect a jumper between COM and GND; if a balanced output line is used, no jumper is required.

Optimum performance of any transistor amplifier depends on the proper current delivered at the output terminals. Connecting a total load impedance at any tap less than the impedance indicated on the back panel of the amplifier will cause the transistors to deliver more current than they were designed for and will deteriorate the performance of the unit and cause damage to the transistors. To prevent this from occurring and to protect the components, the unit is equipped with a circuit breaker that will trip if the output impedance is below the specified rated value; for example, if two 8 ohm speakers are connected in parallel (resulting in a 4 ohm impedance), and in turn connected to the 8 ohm output terminal, the circuit breaker will trip as soon as the volume control is turned up to the unit's maximum output.

The circuit breaker located on the rear panel protects the unit from drawing excessive AC line current which could cause damage to the internal components.

Free Manuals Download Website

<http://myh66.com>

<http://usermanuals.us>

<http://www.somanuals.com>

<http://www.4manuals.cc>

<http://www.manual-lib.com>

<http://www.404manual.com>

<http://www.luxmanual.com>

<http://aubethermostatmanual.com>

Golf course search by state

<http://golfingnear.com>

Email search by domain

<http://emailbydomain.com>

Auto manuals search

<http://auto.somanuals.com>

TV manuals search

<http://tv.somanuals.com>