

# **TAS5110D6REF**

**Reference Design for the TAS5110DAD Digital  
Audio PWM Power Output Stage**

## *User's Guide*

## IMPORTANT NOTICE

Texas Instruments Incorporated and its subsidiaries (TI) reserve the right to make corrections, modifications, enhancements, improvements, and other changes to its products and services at any time and to discontinue any product or service without notice. Customers should obtain the latest relevant information before placing orders and should verify that such information is current and complete. All products are sold subject to TI's terms and conditions of sale supplied at the time of order acknowledgment.

TI warrants performance of its hardware products to the specifications applicable at the time of sale in accordance with TI's standard warranty. Testing and other quality control techniques are used to the extent TI deems necessary to support this warranty. Except where mandated by government requirements, testing of all parameters of each product is not necessarily performed.

TI assumes no liability for applications assistance or customer product design. Customers are responsible for their products and applications using TI components. To minimize the risks associated with customer products and applications, customers should provide adequate design and operating safeguards.

TI does not warrant or represent that any license, either express or implied, is granted under any TI patent right, copyright, mask work right, or other TI intellectual property right relating to any combination, machine, or process in which TI products or services are used. Information published by TI regarding third-party products or services does not constitute a license from TI to use such products or services or a warranty or endorsement thereof. Use of such information may require a license from a third party under the patents or other intellectual property of the third party, or a license from TI under the patents or other intellectual property of TI.

Reproduction of information in TI data books or data sheets is permissible only if reproduction is without alteration and is accompanied by all associated warranties, conditions, limitations, and notices. Reproduction of this information with alteration is an unfair and deceptive business practice. TI is not responsible or liable for such altered documentation.

Resale of TI products or services with statements different from or beyond the parameters stated by TI for that product or service voids all express and any implied warranties for the associated TI product or service and is an unfair and deceptive business practice. TI is not responsible or liable for any such statements.

Following are URLs where you can obtain information on other Texas Instruments products and application solutions:

<b>Products</b>		<b>Applications</b>	
Amplifiers	<a href="http://amplifier.ti.com">amplifier.ti.com</a>	Audio	<a href="http://www.ti.com/audio">www.ti.com/audio</a>
Data Converters	<a href="http://dataconverter.ti.com">dataconverter.ti.com</a>	Automotive	<a href="http://www.ti.com/automotive">www.ti.com/automotive</a>
DSP	<a href="http://dsp.ti.com">dsp.ti.com</a>	Broadband	<a href="http://www.ti.com/broadband">www.ti.com/broadband</a>
Interface	<a href="http://interface.ti.com">interface.ti.com</a>	Digital Control	<a href="http://www.ti.com/digitalcontrol">www.ti.com/digitalcontrol</a>
Logic	<a href="http://logic.ti.com">logic.ti.com</a>	Military	<a href="http://www.ti.com/military">www.ti.com/military</a>
Power Mgmt	<a href="http://power.ti.com">power.ti.com</a>	Optical Networking	<a href="http://www.ti.com/opticalnetwork">www.ti.com/opticalnetwork</a>
Microcontrollers	<a href="http://microcontroller.ti.com">microcontroller.ti.com</a>	Security	<a href="http://www.ti.com/security">www.ti.com/security</a>
		Telephony	<a href="http://www.ti.com/telephony">www.ti.com/telephony</a>
		Video & Imaging	<a href="http://www.ti.com/video">www.ti.com/video</a>
		Wireless	<a href="http://www.ti.com/wireless">www.ti.com/wireless</a>

Mailing Address: Texas Instruments  
Post Office Box 655303 Dallas, Texas 75265

Copyright © 2003, Texas Instruments Incorporated

## EVM IMPORTANT NOTICE

Texas Instruments (TI) provides the enclosed product(s) under the following conditions:

This evaluation kit being sold by TI is intended for use for **ENGINEERING DEVELOPMENT OR EVALUATION PURPOSES ONLY** and is not considered by TI to be fit for commercial use. As such, the goods being provided may not be complete in terms of required design-, marketing-, and/or manufacturing-related protective considerations, including product safety measures typically found in the end product incorporating the goods. As a prototype, this product does not fall within the scope of the European Union directive on electromagnetic compatibility and therefore may not meet the technical requirements of the directive.

Should this evaluation kit not meet the specifications indicated in the EVM User's Guide, the kit may be returned within 30 days from the date of delivery for a full refund. **THE FOREGOING WARRANTY IS THE EXCLUSIVE WARRANTY MADE BY SELLER TO BUYER AND IS IN LIEU OF ALL OTHER WARRANTIES, EXPRESSED, IMPLIED, OR STATUTORY, INCLUDING ANY WARRANTY OF MERCHANTABILITY OR FITNESS FOR ANY PARTICULAR PURPOSE.**

The user assumes all responsibility and liability for proper and safe handling of the goods. Further, the user indemnifies TI from all claims arising from the handling or use of the goods. Please be aware that the products received may not be regulatory compliant or agency certified (FCC, UL, CE, etc.). Due to the open construction of the product, it is the user's responsibility to take any and all appropriate precautions with regard to electrostatic discharge.

**EXCEPT TO THE EXTENT OF THE INDEMNITY SET FORTH ABOVE, NEITHER PARTY SHALL BE LIABLE TO THE OTHER FOR ANY INDIRECT, SPECIAL, INCIDENTAL, OR CONSEQUENTIAL DAMAGES.**

TI currently deals with a variety of customers for products, and therefore our arrangement with the user **is not exclusive**.

TI assumes **no liability for applications assistance, customer product design, software performance, or infringement of patents or services described herein**.

Please read the EVM User's Guide and, specifically, the EVM Warnings and Restrictions notice in the EVM User's Guide prior to handling the product. This notice contains important safety information about temperatures and voltages. For further safety concerns, please contact the TI application engineer.

Persons handling the product must have electronics training and observe good laboratory practice standards.

No license is granted under any patent right or other intellectual property right of TI covering or relating to any machine, process, or combination in which such TI products or services might be or are used.

Mailing Address:

Texas Instruments  
Post Office Box 655303  
Dallas, Texas 75265

Copyright © 2003, Texas Instruments Incorporated

## **EVM WARNINGS AND RESTRICTIONS**

It is important to operate this EVM within the specified input and output ranges described in the EVM User's Guide.

Exceeding the specified input range may cause unexpected operation and/or irreversible damage to the EVM. If there are questions concerning the input range, please contact a TI field representative prior to connecting the input power.

Applying loads outside of the specified output range may result in unintended operation and/or possible permanent damage to the EVM. Please consult the EVM User's Guide prior to connecting any load to the EVM output. If there is uncertainty as to the load specification, please contact a TI field representative.

During normal operation, some circuit components may have case temperatures greater than 60°C. The EVM is designed to operate properly with certain components above 60°C as long as the input and output ranges are maintained. These components include but are not limited to linear regulators, switching transistors, pass transistors, and current sense resistors. These types of devices can be identified using the EVM schematic located in the EVM User's Guide. When placing measurement probes near these devices during operation, please be aware that these devices may be very warm to the touch.

### **Mailing Address:**

Texas Instruments  
Post Office Box 655303  
Dallas, Texas 75265

Copyright © 2003, Texas Instruments Incorporated

# Read This First

---

---

---

---

### ***About This Manual***

This manual describes the operation of the TAS5110D6REF evaluation module from Texas Instruments.

### ***How to Use This Manual***

This document contains the following chapters:

- Chapter 1 – Introduction
- Chapter 2 – System Interfaces
- Chapter 3 – Electrical Specifications and Typical Characteristics Graphs
- Chapter 4 – Schematic, Parts List, PCB Specification, and PCB Layout

### ***Information About Cautions and Warnings***

This book may contain cautions and warnings.

**This is an example of a caution statement.**

**A caution statement describes a situation that could potentially damage your software or equipment.**

**This is an example of a warning statement.**

**A warning statement describes a situation that could potentially cause harm to you.**

The information in a caution or a warning is provided for your protection. Please read each caution and warning carefully.

***Related Documentation From Texas Instruments***

The following is a list of data manual that have detailed descriptions of the integrated circuits used in the design of the TAS5110D6REF evaluation module. The data manuals can be obtained at the URL <http://www.ti.com>.

<b>Part Number</b>	<b>Literature Number</b>
TAS5110A	SLES079
SN74LVC2G126DCT	SCES205
TPS75333QPWP	SLVS241

# Contents

---

---

---

<b>1</b>	<b>Introduction</b> .....	<b>1-1</b>
1.1	TAS5110D6REF Features .....	1-2
1.2	PCB Key Map .....	1-3
1.3	Short-Circuit Protection and Fault Reporting Circuitry .....	1-4
1.3.1	Device Fault Reporting .....	1-4
1.3.2	Short-Circuit Protection .....	1-4
1.3.3	Autorecovery System .....	1-4
<b>2</b>	<b>System Interfaces</b> .....	<b>2-1</b>
2.1	PSU Interface (J150) .....	2-2
2.2	PSU Control Interface (J160) .....	2-3
2.3	Loudspeaker Connectors (J240, J280, J340, J380, J440, and J480) .....	2-3
2.4	PWM Interface (J100) .....	2-4
<b>3</b>	<b>Electrical Specifications and Typical Characteristics Graphs</b> .....	<b>3-1</b>
3.1	TAS5110D6REF Electrical Specifications .....	3-2
3.2	Physical Specifications .....	3-2
3.3	Typical Characteristics Graphs .....	3-3
<b>4</b>	<b>Schematic, Parts List, PCB Specification, and PCB Layout</b> .....	<b>4-1</b>

# Figures

---

---

---

1-1	TDAA System With TAS5026REF/TAS5036 and TAS5110D6REF Modules .....	1-2
1-2	Physical Structure for the TAS5110D6REF (Rough Outline) .....	1-3
1-3	Auto Recovery Loop .....	1-5
2-1	Recommended TAS5110 Power-Up Sequence .....	2-2
2-2	Pin Numbers at the PSU Interface (Top View) .....	2-2
2-3	Pin Numbers at the PSU Control Interface .....	2-3
2-4	Pin Numbers at the Loudspeaker Connectors .....	2-3
2-5	Pin Numbers at PWM Interface (J100) .....	2-4
3-1	THD+N vs Frequency – Channel 1 .....	3-3
3-2	THD+N vs Power – Channel 1, 3, and 5 .....	3-3
3-3	THD+N vs Power – Channel 2, 4, and 6 .....	3-4
3-4	FFT With –60 dB Input Signal – Channel 1 .....	3-4
3-5	FFT at 40-W Output Power – Channel 1 .....	3-5
3-6	Noise Floor – Channel 1 .....	3-5
3-7	Channel Separation vs Frequency – Channel 1 .....	3-6
3-8	Frequency Response – Channel 1 .....	3-6

# Tables

---

---

---

1-1	Device Fault Reporting .....	1-4
2-1	J150 Pin Description .....	2-2
2-2	PSU Control Interface Pin Connections .....	2-3
2-3	Description of Loudspeaker Connectors .....	2-3
2-4	J100 Pin Description .....	2-4



# Introduction

---

---

---

---

The true digital audio amplifiers (TDAA) system consists of a PCM–PWM modulator device and a PWM power output device. The PCM–PWM processor accepts a serial PCM digital audio stream and converts it to a 3.3-V PWM audio stream. The TDAA output stage provides a large-signal PWM output. The digital PWM signal is then demodulated providing power output for driving loudspeakers. This patented technology provides low cost, high quality, high efficient digital audio applicable to many audio systems developed for the digital age.

The TAS5110D6REF reference design demonstrates the integrated circuit TAS5110DAD from Texas Instruments (TI). The board does not contain any PWM processors. A separate and compatible PWM processor board (such as TAS5026REF) is available.

The TAS5110 is a single channel PWM power audio device. It contains integrated gate drivers, four matched and electrically isolated enhancement-mode N-channel power DMOS transistors, and protection and fault-reporting circuitry. This device is optimized for use with the TAS50XX PWM processor family.

Together with the TAS5026REF module or the TAS5036REF module, the TAS5110D6REF module is a complete true digital audio amplifier system, which includes digital volume control, headphone amplifier, and a subwoofer output.

<b>Topic</b>	<b>Page</b>
<b>1.1 TAS5110D6REF Features .....</b>	<b>1-2</b>
<b>1.2 PCB Key Map .....</b>	<b>1-3</b>
<b>1.3 Short-Circuit Protection and Fault Reporting Circuitry .....</b>	<b>1-4</b>

## 1.1 TAS5110D6REF Features

- ❑ Six channel TDAA reference design (double-sided plated-through PCB layout)
- ❑ Supports noiseless self-contained protection system (short circuit and thermal)
- ❑ Supports both two-level modulation (AD-modulation scheme) and three-level modulation (BD-modulation scheme)
- ❑ Onboard subwoofer output (line level)

Figure 1–1. TDAA System With TAS5026REF/TAS5036 and TAS5110D6REF Modules

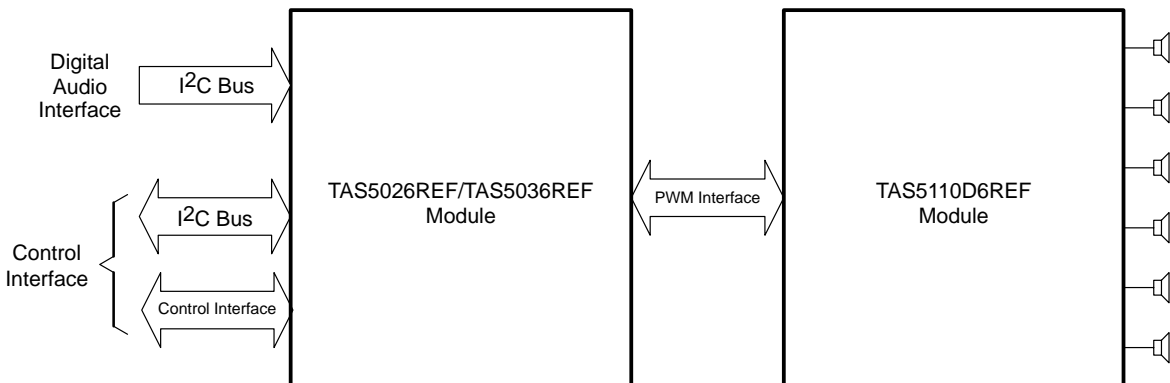

The TAS5026 processor is a two-level PCM-to-PWM modulator and the TAS5036 processor is a three-level modulator.

## 1.2 PCB Key Map

The physical structure for the TAS5110D6REF is illustrated in Figure 1–2.

Figure 1–2. Physical Structure for the TAS5110D6REF (Rough Outline)

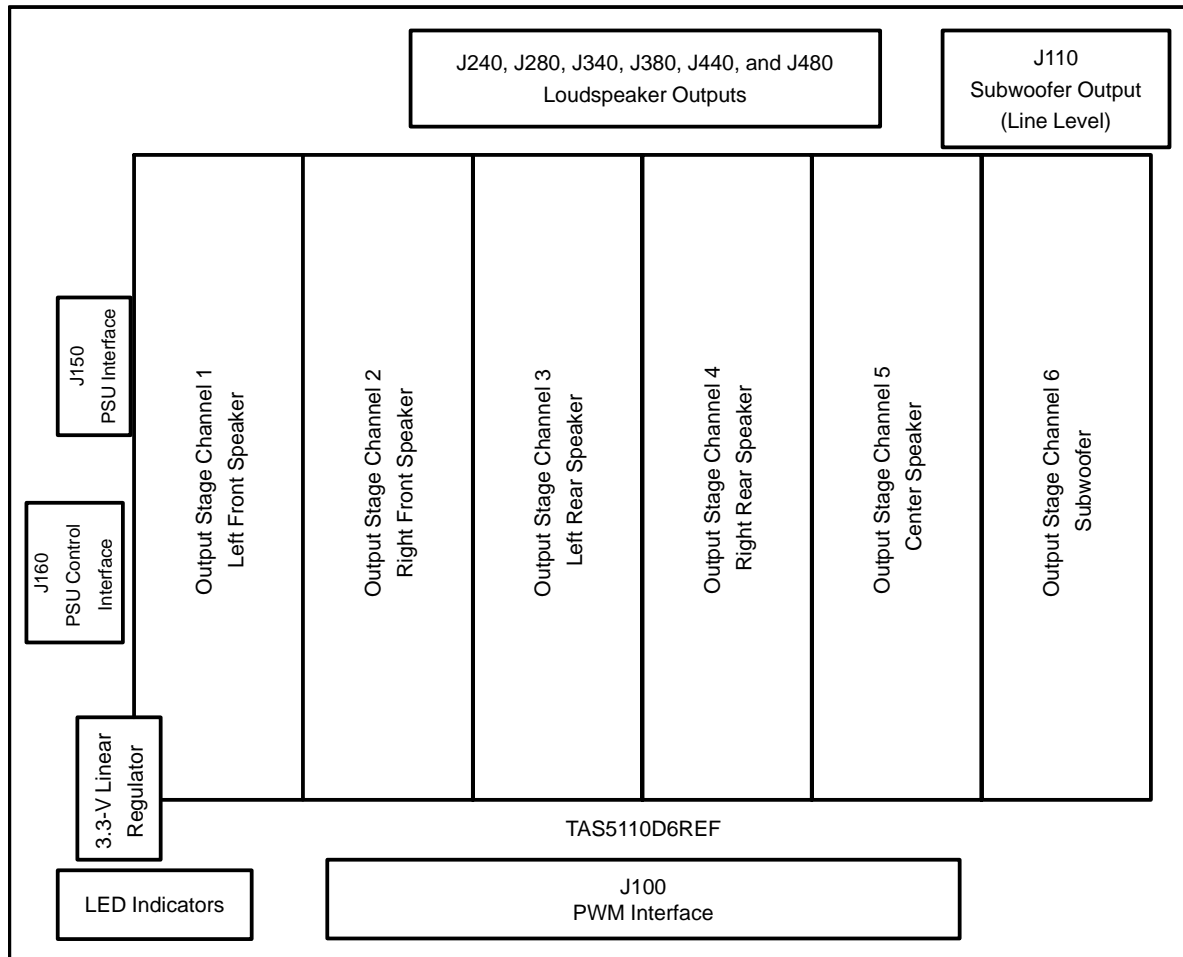

### 1.3 Short-Circuit Protection and Fault Reporting Circuitry

The TAS5110 is a self-protecting device that provides device fault reporting (including over-temperature protect and short-circuit protection).

#### 1.3.1 Device Fault Reporting

The  $\overline{\text{ERR0}}$ ,  $\overline{\text{ERR1}}$ , and  $\overline{\text{SHUTDOWN}}$  outputs from TAS5110 indicates the device conditions shown in Table 1–1. The device fault reporting outputs are open-drain outputs.

Table 1–1. Device Fault Reporting

$\overline{\text{SHUTDOWN}}$	$\overline{\text{ERR0}}$	$\overline{\text{ERR1}}$	DEVICE CONDITION
0	0	0	Illegal PWM input state
0	0	1	Short-circuit protect
0	1	0	Over temperature protect
0	1	1	Low regulator voltage protect
1	0	0	Reserved
1	0	1	Reserved
1	1	0	High temperature warning
1	1	1	Normal operation

#### 1.3.2 Short-Circuit Protection

The short-circuit protect error condition latches the TAS5110 in the shutdown mode:

- H-bridge outputs (OUTPUTA and OUTPUTB) are in a high-impedance state (Hi-Z state).
- $\overline{\text{SHUTDOWN}}$  is asserted low.
- $\overline{\text{ERR0}}$  is high and  $\overline{\text{ERR1}}$  is asserted low.
- The H-bridge outputs remains in a Hi-Z state until the device is reset ( $\overline{\text{RESET}}$  pin asserted low).

The TAS5110 is not designed for driving load impedance less than 4  $\Omega$  (at 20-Vdc output stage supply), where the internal current limit protection is activated at high power levels.

#### 1.3.3 Auto Recovery System

Together with a PWM processor from Texas Instruments (e.g., the TAS5026 or the TAS5036), the TAS5110 can be configured in autorecovery mode. The  $\overline{\text{SHUTDOWN}}$  signal from the TAS5110 is in autorecovery mode connected to  $\overline{\text{ERR\_RCVY}}$  at the PWM processor.

The short-circuit protect error condition results in the following autorecovery sequence:

- ❑ H-bridge outputs (OUTPUTA and OUTPUTB) are in a high-impedance state (Hi-Z state).
- ❑  $\overline{\text{ERR\_RCVY}}$  at the PWM processor is forced low by the  $\overline{\text{SHUTDOWN}}$  signal.
- ❑  $\overline{\text{RESET}}$  at the TAS5110 is forced low by the  $\overline{\text{VALID}}$  signal.
- ❑ The  $\overline{\text{VALID}}$  signal goes high after 4 ms and then the TAS5110 starts switching again.

Figure 1–3. Auto Recovery Loop

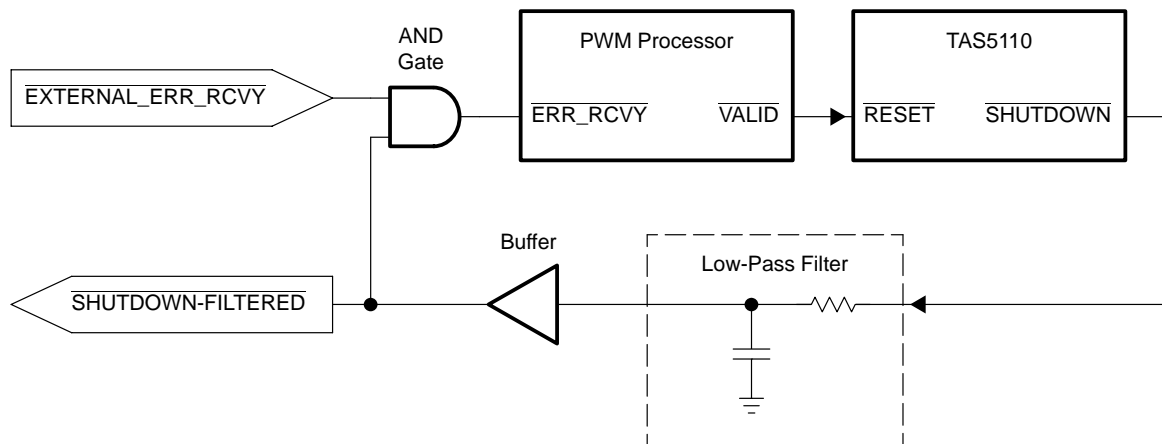

The autorecovery loop is closed when the TAS5110D6REF board is connected to the TAS5026REF or TAS5036REF module.



# System Interfaces

---

---

---

---

This chapter describes the TAS5110D6REF system interfaces.

<b>Topic</b>	<b>Page</b>
<b>2.1 PSU Interface (J150) .....</b>	<b>2-2</b>
<b>2.2 PSU Control Interface (J160) .....</b>	<b>2-3</b>
<b>2.3 Loudspeaker Connectors (J240, J280, J340, J440, and J480) .....</b>	<b>2-3</b>
<b>2.4 PWM Interface (J100) .....</b>	<b>2-4</b>

## 2.1 PSU Interface (J150)

The TAS5110D6DAD board must be powered from external power supplies. High-end audio performance requires a stabilized power supply with low ripple voltage and low output impedance.

**Note:**

The length of the power-supply cable must be minimized. Increasing the impedance of the PSU cable is equal to increasing the distortion for the amplifier at high output levels and low frequencies.

The maximum output stage supply voltage depends on the speaker load resistance. See the recommended maximum supply voltage in Chapter 4.

Description	$R_L = 4 \Omega$	$R_L = 6 \Omega$	$R_L = 8 \Omega$
Supply voltage for output stage	0 V – 20 V	0 V – 26.5 V	0 V – 26.5 V
Supply voltage for gate drive	22 V (min 16.5 V, max 26.5 V)		
Supply voltage for control	5 V (min 4.5 V, max 5.3 V)		

The recommended TAS5110 power-up sequence is shown in Figure 2–1. For proper TAS5110 operation, the  $\overline{\text{RESET}}$  signal should be kept low during power up.  $\overline{\text{RESET}}$  is pulled low during power up for 100 ms by the onboard low-drop linear regulator (U170).

Figure 2–1. Recommended TAS5110 Power-Up Sequence

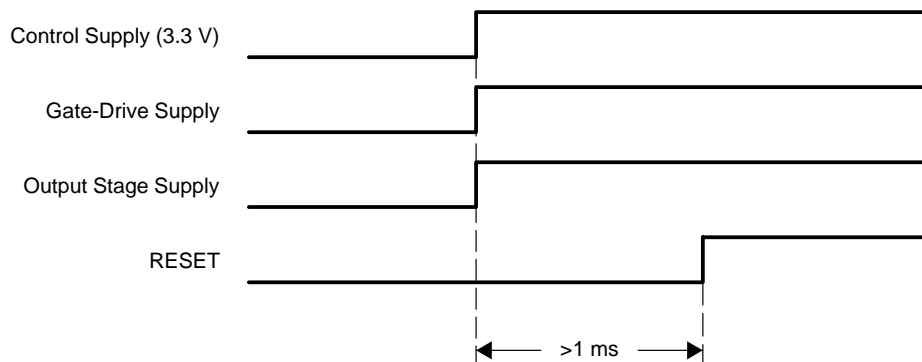

Figure 2–2. Pin Numbers at the PSU Interface (Top View)

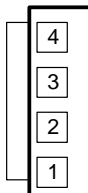

Table 2–1. J150 Pin Description

Pin No.	Net Name at Schematic	Description
1	Power output stage	H-bridge supply voltage
2	GND	Ground
3	Gate-drive supply	Gate-drive supply voltage ( $I \approx 90 \text{ mA}$ )
4	5 V	Control supply voltage ( $I \approx 100 \text{ mA}$ )



## 2.2 PSU Control Interface (J160)

This interface is not used in this board.

Figure 2–3. Pin Numbers at the PSU Control Interface

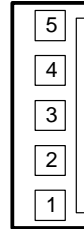

Table 2–2. PSU Control Interface Pin Connections

Pin No.	Pin Description	Net Name at TAS5110D6REF Schematic
1	For future use	
2	For future use	
3	Ground	GND
4	System reset (bidirectional)	$\overline{\text{RESET}}$
5	For future use	V-HBRIDGE-CONTROL

## 2.3 Loudspeaker Connectors (J240, J280, J340, J380, J440, and J480)

Figure 2–4. Pin Numbers at the Loudspeaker Connectors



Table 2–3. Description of Loudspeaker Connectors

Pin No.	Pin Description
2	Speaker positive output terminal
1	Speaker negative output terminal

### Caution

Both positive and negative speaker outputs are floating and may not be connected to ground (e.g., through an oscilloscope).

## 2.4 PWM Interface (J100)

This interface connects the TAS5110D6REF board to the PWM processor module (e.g., TAS5026REF).

Figure 2–5. Pin Numbers at PWM Interface (J100)

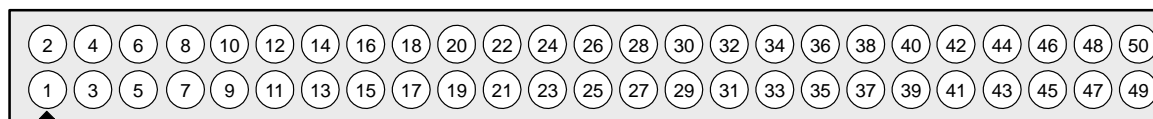

Connector: 50 positions, 2,54-mm pitch, double row IDC connector (Multicom MC9A12–5034).

Table 2–4. J100 Pin Description

Pin No.	Net Name	Description
01	V-HBRIDGE-CONTROL	For future use
02	GND	Ground
03	PWM-AP-1	Channel 1 PWM input (differential +) – positive H-bridge side
04	PWM-AM-1	Channel 1 PWM input (differential –) – positive H-bridge side
05	VALID-1	Valid channel 1
06	PWM-BM-1	Channel 1 PWM input (differential –) – negative H-bridge side
07	PWM-BP-1	Channel 1 PWM input (differential +) – negative H-bridge side
08	GND	Ground
09	PWM-AP-2	Channel 2 PWM input (differential +) – positive H-bridge side
10	PWM-AM-2	Channel 2 PWM input (differential –) – positive H-bridge side
11	VALID-2	Valid channel 2
12	PWM-BM-2	Channel 2 PWM input (differential –) – negative H-bridge side
13	PWM-BP-2	Channel 2 PWM input (differential +) – negative H-bridge side
14	GND	Ground
15	PWM-AP-3	Channel 3 PWM input (differential +) – positive H-bridge side
16	PWM-AM-3	Channel 3 PWM input (differential –) – positive H-bridge side
17	VALID-3	Valid channel 3
18	PWM-BM-3	Channel 3 PWM input (differential –) – negative H-bridge side
19	PWM-BP-3	Channel 3 PWM input (differential +) – negative H-bridge side
20	GND	Ground
21	PWM-AP-4	Channel 4 PWM input (differential +) – positive H-bridge side
22	PWM-AM-4	Channel 4 PWM input (differential –) – positive H-bridge side
23	VALID-4	Valid channel 4
24	PWM-BM-4	Channel 4 PWM input (differential –) – negative H-bridge side
25	PWM-BP-4	Channel 4 PWM input (differential +) – negative H-bridge side
26	GND	Ground
27	PWM-AP-5	Channel 5 PWM input (differential +) – positive H-bridge side

Table 2–4. J100 Pin Description (Continued)

Pin No.	Net Name	Description
28	PWM-AM-5	Channel 5 PWM input (differential –) – positive H-bridge side
29	$\overline{\text{VALID}}-5$	Valid channel 5
30	PWM-BM-5	Channel 5 PWM input (differential –) – negative H-bridge side
31	PWM-BP-5	Channel 5 PWM input (differential +) – negative H-bridge side
32	GND	Ground
33	PWM-AP-6	Channel 6 PWM input (differential +) – positive H-bridge side
34	PWM-AM-6	Channel 6 PWM input (differential –) – positive H-bridge side
35	$\overline{\text{VALID}}-6$	Valid channel 6
36	PWM-BM-6	Channel 6 PWM input (differential –) – negative H-bridge side
37	PWM-BP-6	Channel 6 PWM input (differential +) – negative H-bridge side
38	$\overline{\text{SD}}-E1$	Shutdown group 1 (center + left and right front speakers)
39	$\overline{\text{SD}}-E2$	Shutdown group 2 (subwoofer + left and right rear speakers)
40	$\overline{\text{ERROR}}0$	Error signal ERR0 from TAS5110
41	$\overline{\text{ERROR}}1$	Error signal ERR1 from TAS5110
42	$\overline{\text{RESET}}$	System reset (bidirectional)
43	PSU-COMP-2	For future use
44	PSU-COMP-1	For future use
45	Not Used	For future use
46	Not Used	For future use
47	+3.3V	3.3-V supply voltage for the modulator module (e.g., the TAS5026REF)
48	GND	Ground
49	+5V	5-V supply voltage
50	+5V	5-V supply voltage



# Electrical Specifications and Typical Characteristics Graphs

---

---

---

---

This chapter contains the electrical specifications and the typical characteristics graphs.

<b>Topic</b>	<b>Page</b>
<b>3.1 Electrical Specifications .....</b>	<b>3-2</b>
<b>3.2 Physical Specifications .....</b>	<b>3-2</b>
<b>3.3 Typical Characteristics Graphs .....</b>	<b>3-3</b>

### 3.1 TAS5110D6REF Electrical Specifications

General Test Conditions					
PARAMETER	TEST CONDITIONS	MIN	TYP	MAX	UNIT
Output stage power supply	Laboratory power supply (EA-PS 7065-10A)			26.5	VDC
Gate drive power supply				26.5	VDC
Load impedance		6			$\Omega$
S/PDIF sampling frequency			48		kHz
PWM processor	TAS5026REF (Rev 5) board				
Electrical Data					
Maximum output power (10% THD)	10% THD+N, 1 kHz, $T_A = 25^\circ\text{C}$ , 6 $\Omega$		50/channel		W
Maximum output power (unclipped)	0.15% THD+N, 1 kHz, $T_A = 25^\circ\text{C}$ , 6 $\Omega$		40/channel		W
Continuous maximum output power	After 30 minutes preheat of 1/8 max power in six channels, 10% THD+N, 1 kHz, $T_A = 25^\circ\text{C}$ , 6 $\Omega$ (See Note 1)		2 x 50 W >5 min <sup>†</sup>		W
Rated load impedance	At $V_{(\text{POWER-OUTPUT-STAGE})}$ up to 26.5 V	6		8	$\Omega$
	At $V_{(\text{POWER-OUTPUT-STAGE})}$ up to 20 V	4			
Maximum peak current	1-kHz burst		6		A
Damping factor	1 kHz, load = 8 $\Omega$		13		
Idle switch loss	Six channels, $V_{(\text{POWER-OUTPUT-STAGE})} = 26.5 \text{ V}$		4		W
Gate-drive current	$V_{(\text{GATE-DRIVE-SUPPLY})} = 26.5 \text{ V}$		90		mA
5-V supply current	TAS5110D6REF + TAS5026REF		85		mA
Audio Data					
THD+N, 1 W	1 kHz		0.05%		
THD+N, 30 W	1 kHz		0.09%		
THD+N, 40 W	1 kHz		<0.15 %		
Dynamic range, A-weighted	Ref: rated power, AES17 filter		94		dB
Noise voltage, A-weighted	RMS, AES17 filter		260		$\mu\text{V}$
Channel separation	1 kHz, $P_{\text{OUT}} = 30 \text{ W}$		68		dB
Frequency response	DC – 20 kHz, 40 W, 6 $\Omega$		$\pm 0.5 \text{ dB} - 0.1$		dB

**Note:** All electrical and audio specifications are typical values.

<sup>†</sup> Heatsink solution is a prototype and has to be optimized for end-product mass production by common engineering practice.

### 3.2 Physical Specifications

PCB dimensions	105 x 127 mm (4.13 x 5")	Height x Width
Board weight	0,15 kg (0.33 lb)	Components + PCB

### 3.3 Typical Characteristics Graphs

Figure 3–1. THD+N vs Power – Channel 1, 2, 3, 4, 5, and 6

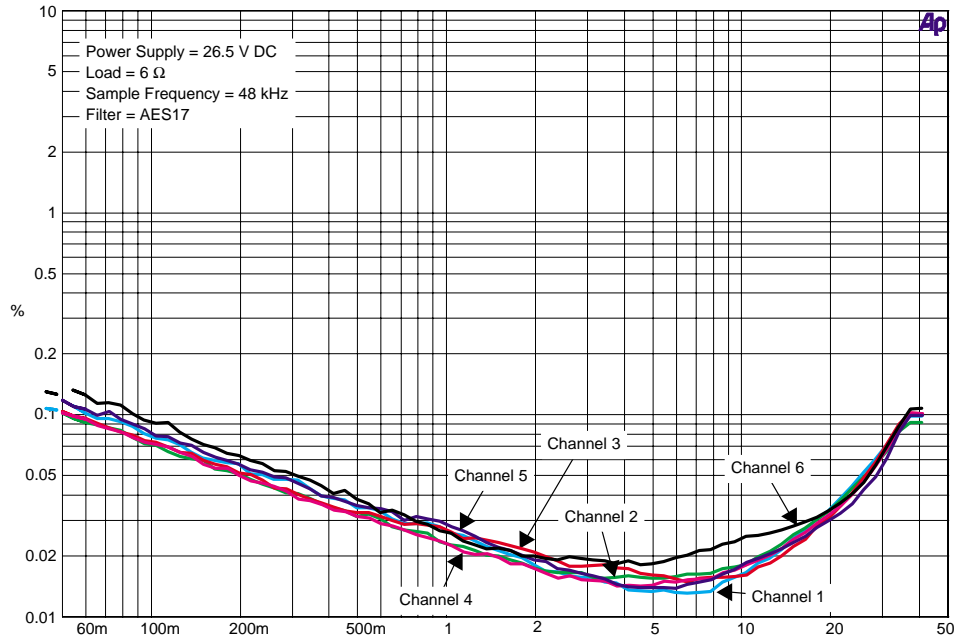
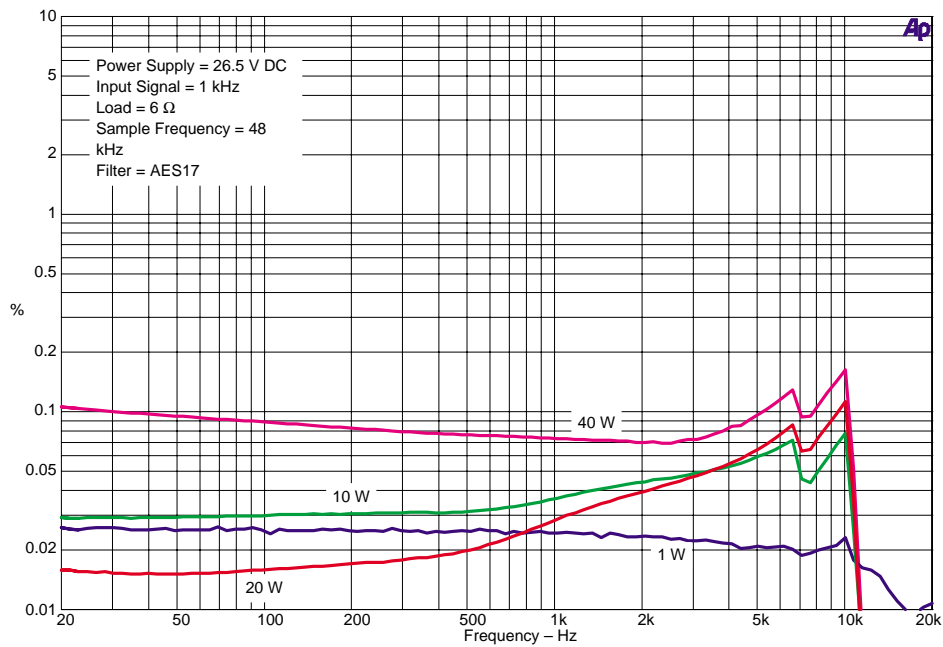

Figure 3–2. THD+N vs Frequency – Channel 1



**Note:** THD+N at high frequencies depends on the output-filter coil material.

Figure 3–3. FFT With –60 dB Input Signal – Channel 1

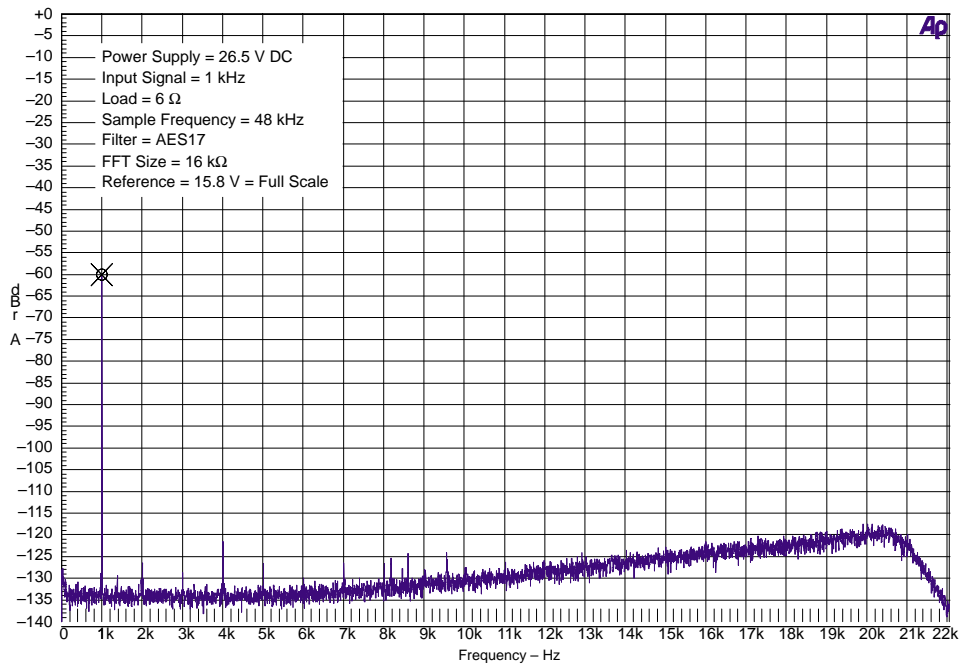

Figure 3–4. Noise Floor – Channel 1

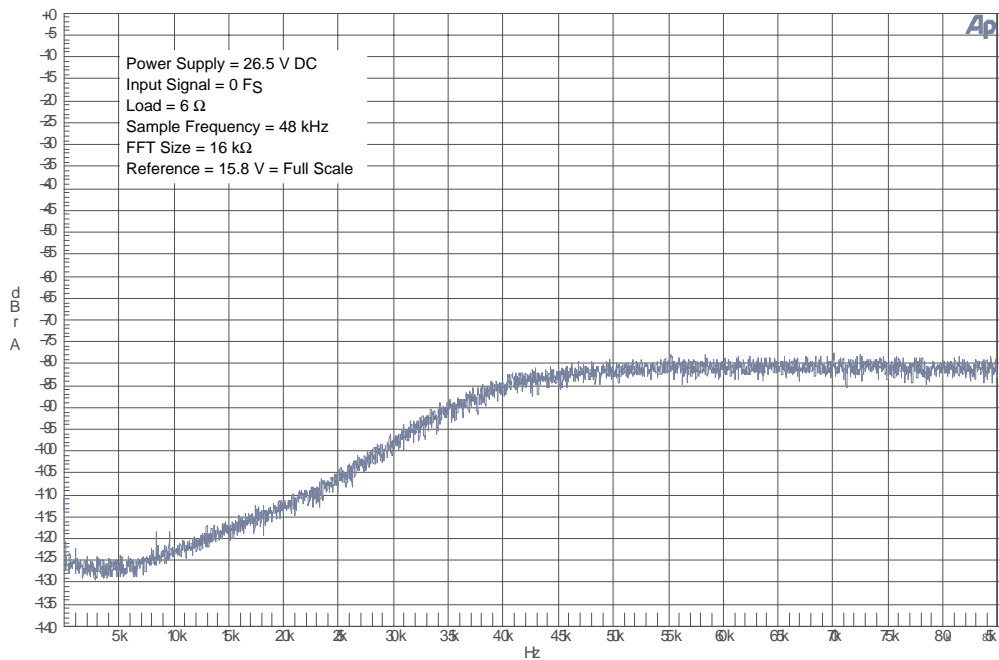



Figure 3–5. Channel Separation vs Frequency – Channel 1

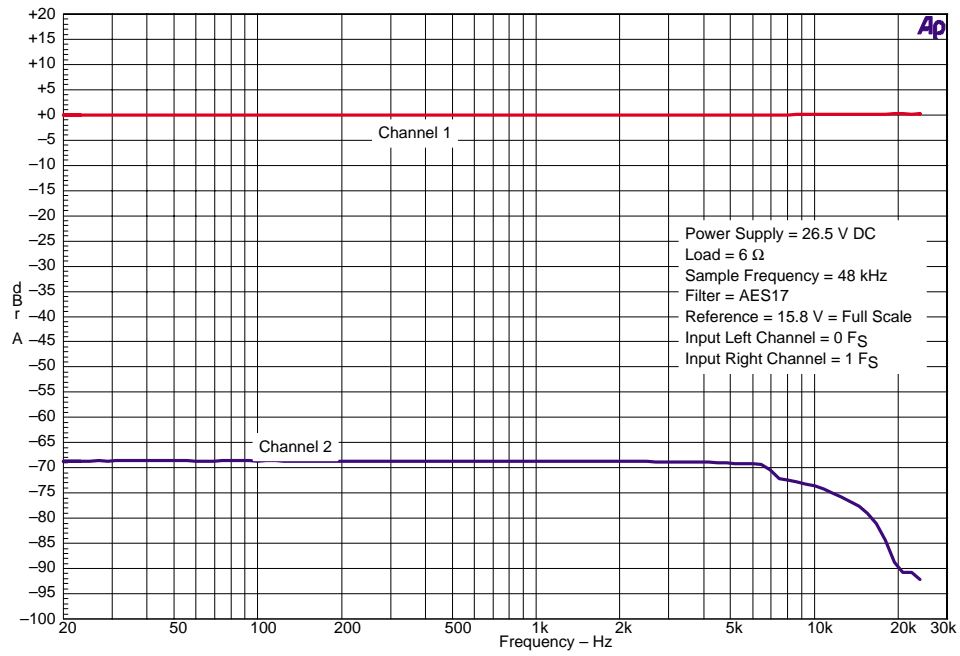

Figure 3–6. Frequency Response – Channel 1

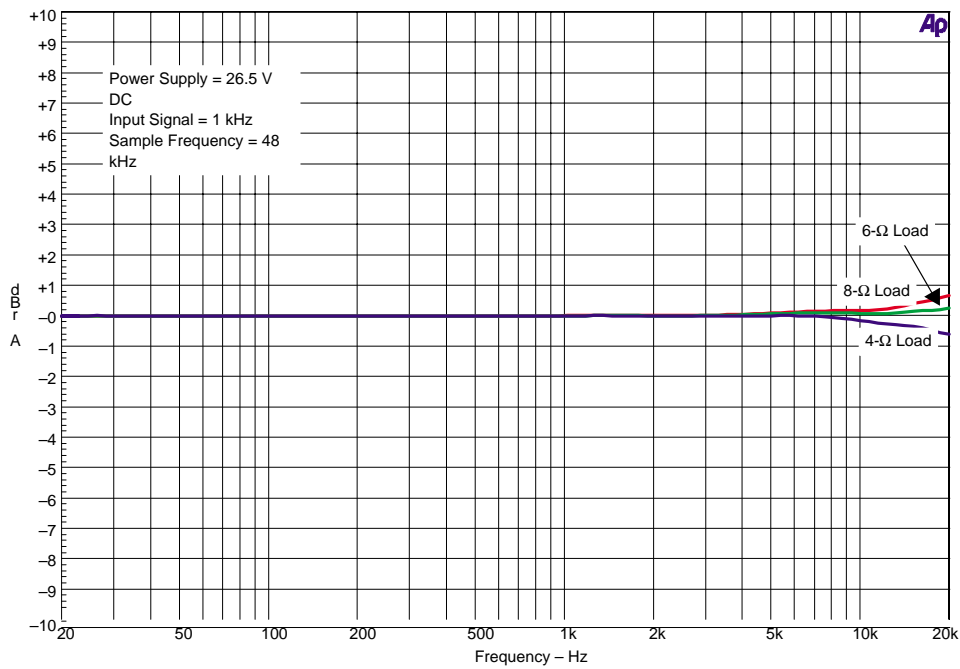
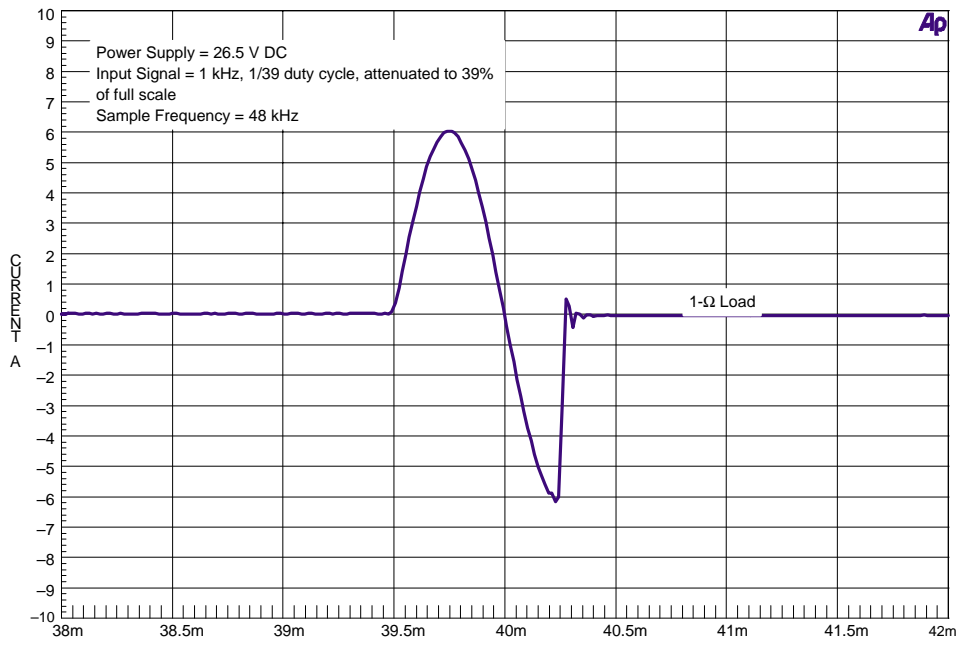

Figure 3–7. Overcurrent Protection – Channel 1

## Typical Characteristics Graphs



# **Schematic, Parts List, PCB Specification, and PCB Layout**

---

---

---

---

The chapter contains the schematic, parts list, PCB specification, and PCB layout for the TAS5110D6REF.

# INPUT SECTION

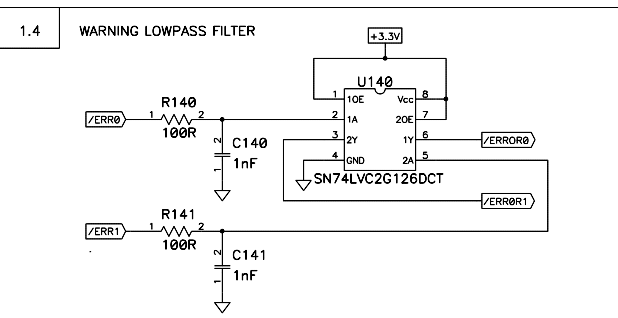
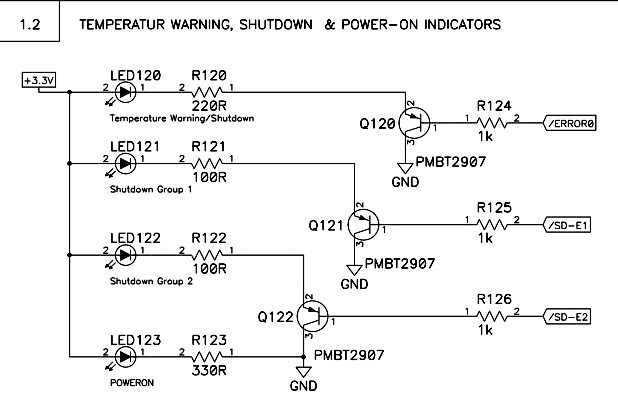
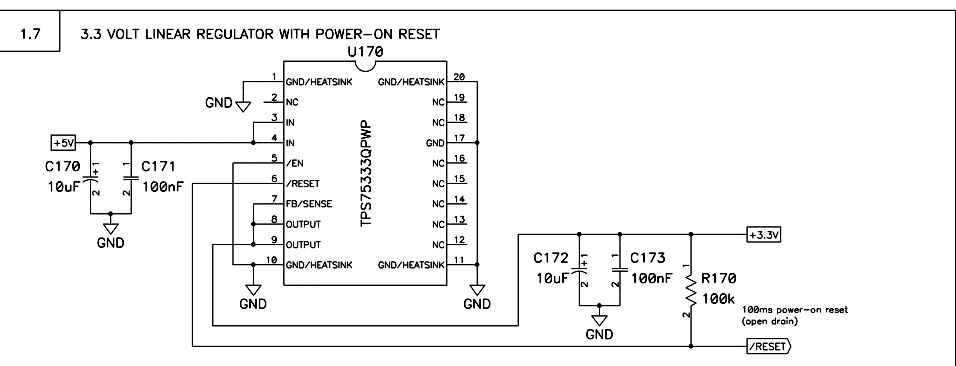
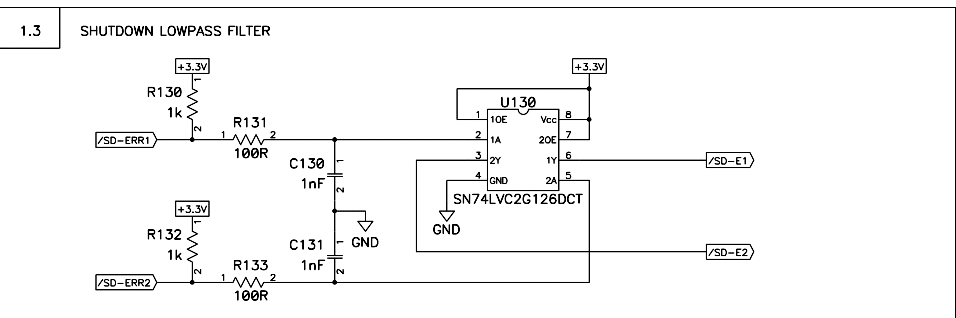
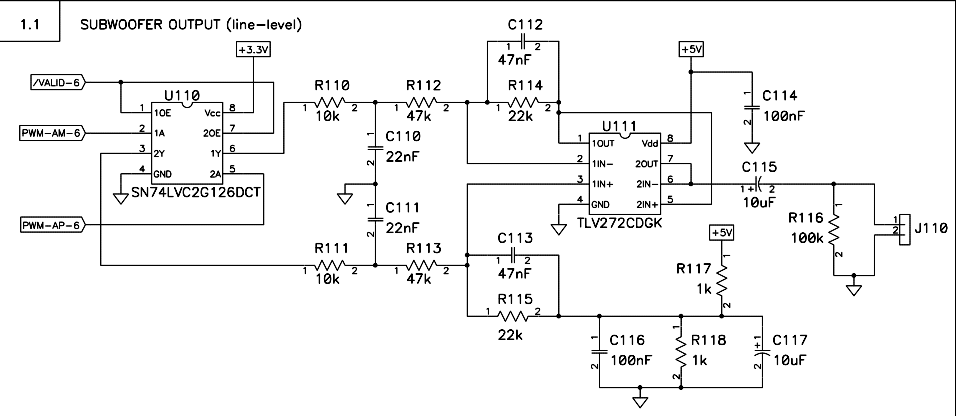
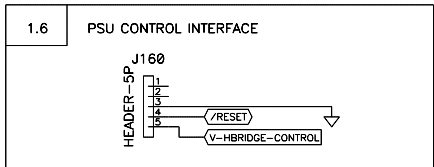
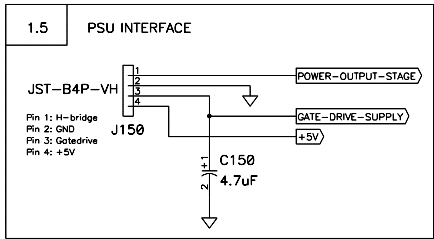
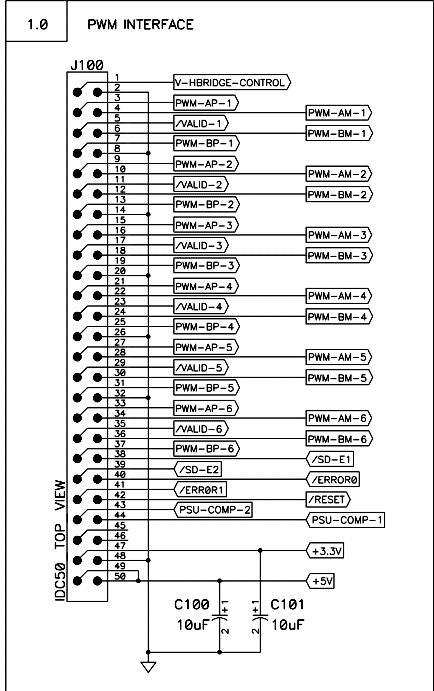

**TEXAS INSTRUMENTS** DIGITAL AUDIO GROUP  
 ALL RIGHTS RESERVED - PATENTS PENDING  
 TEXAS INSTRUMENTS INCORPORATED

Project: **TAS5110D6REF**

Size: A2 Page Title **INPUT SECTION**

Engineers: Claus Reckweg

Date: Thu Sep 26, 2002 Rev: 1.00 Mod: 0 Sheet: 1 of 4

Filename: P167-SCH-001(5.00).sch Drawn by: CRW

File Location:

# Front Speakers

2.0 OUTPUT STAGE CHANNEL 1  
Left Front Speaker

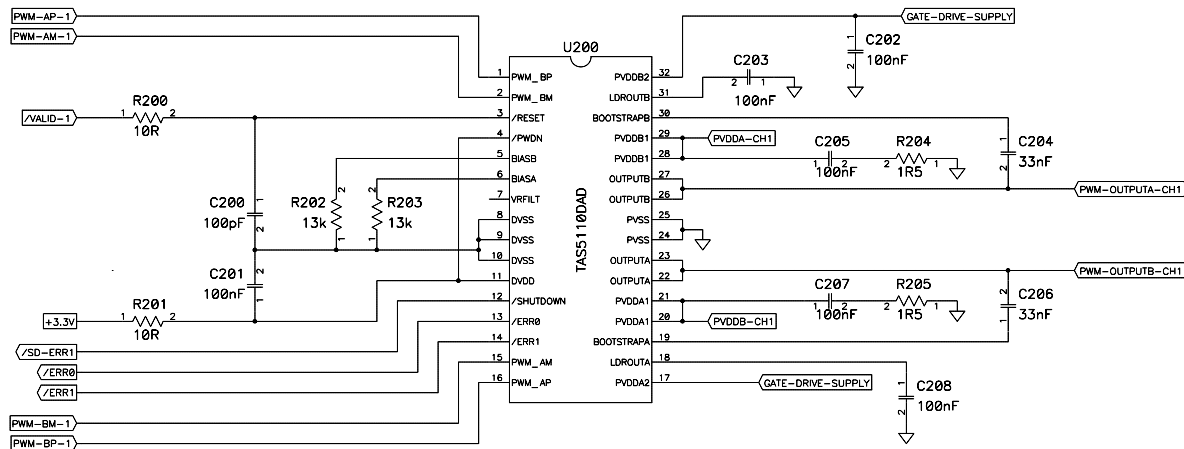

2.2 OUTPUT STAGE CHANNEL 2  
Right Front Speaker

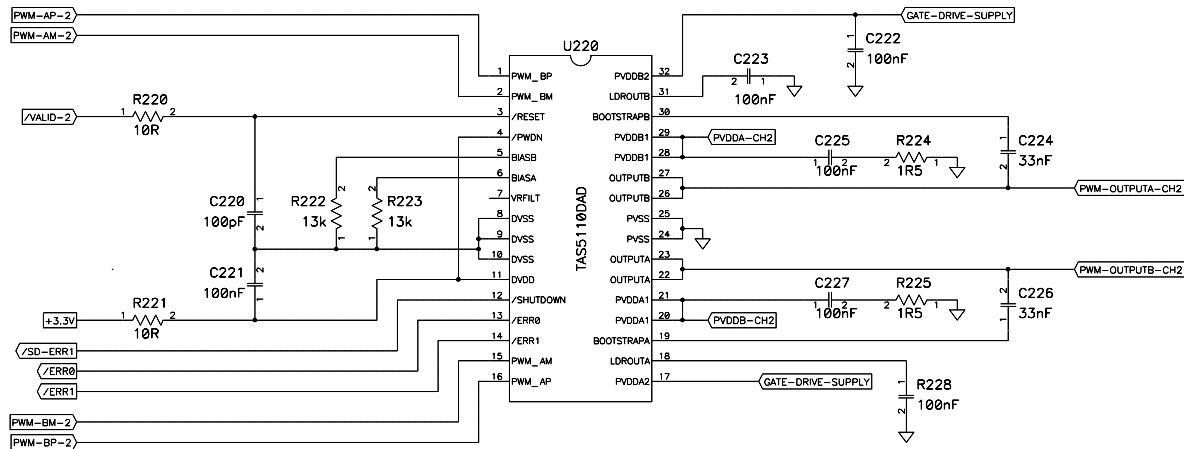

2.4 DEMODULATION FILTER CHANNEL 1

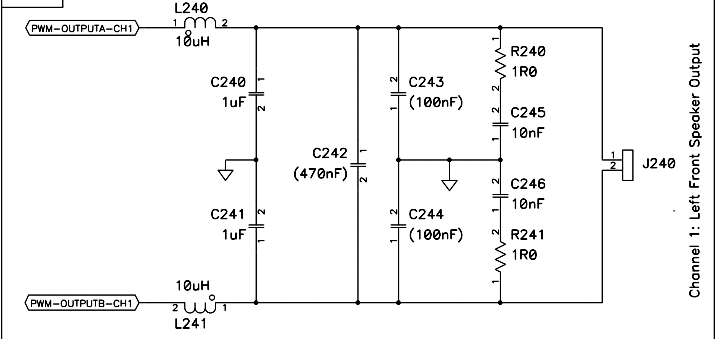

Channel 1: Left Front Speaker Output

2.6 POWER SUPPLY FILTER

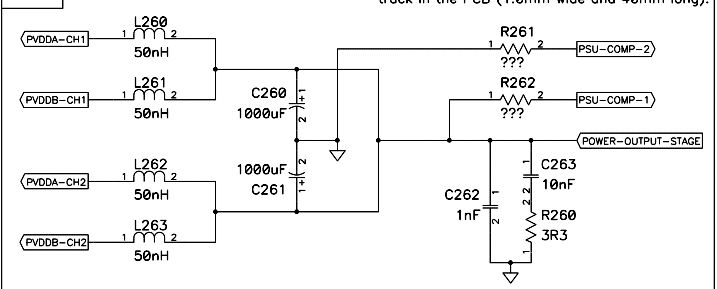

LAYOUT NOTE: L260, L261, L262 and L263 is a track in the PCB (1.0mm wide and 40mm long).

2.8 DEMODULATION FILTER CHANNEL 2

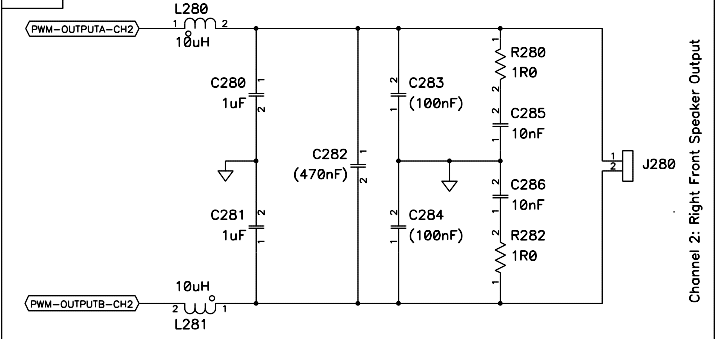

Channel 2: Right Front Speaker Output

Patents pending in circuitry design and layout (WO99/59241 & WO99/59242).  
This circuitry may only be used together with the integrated circuit TAS5100/TAS5110  
from Texas Instruments Incorporated.

**TEXAS INSTRUMENTS** DIGITAL AUDIO GROUP  
ALL RIGHTS RESERVED - PATENTS PENDING  
TEXAS INSTRUMENTS INCORPORATED

Project:	TAS5110D6REF		
Size: A2	Page Title	Front Speakers	
Engineers:	Claus Reckweg	Rev:	1.00
Date:	Thu Sep 26, 2002	Mod:	0
Filename:	P167-SCH-001(5.00).sch	Sheet:	2 of 4
File Location:		Drawn by:	CRW

# Rear Speakers

3.0 OUTPUT STAGE CHANNEL 3  
Left Rear Speaker

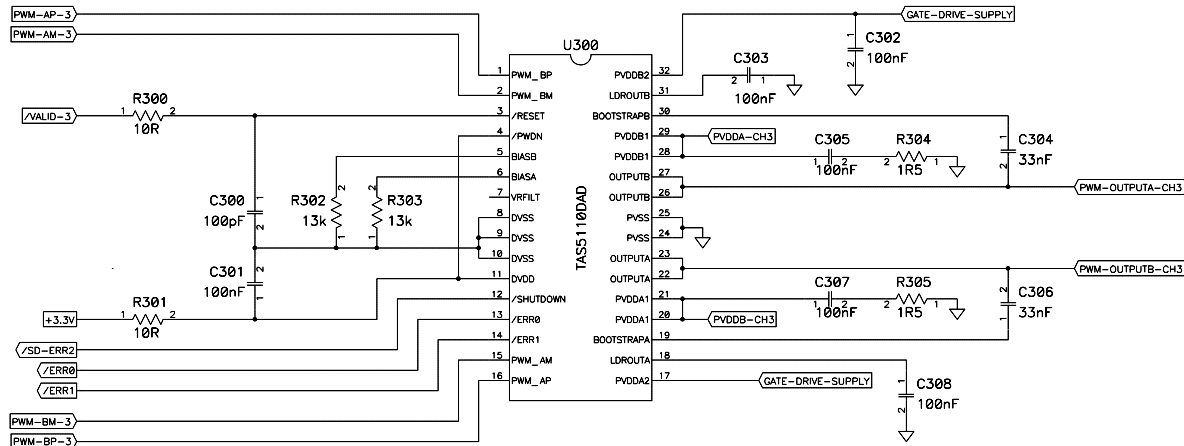

3.2 OUTPUT STAGE CHANNEL 4  
Right Rear Speaker

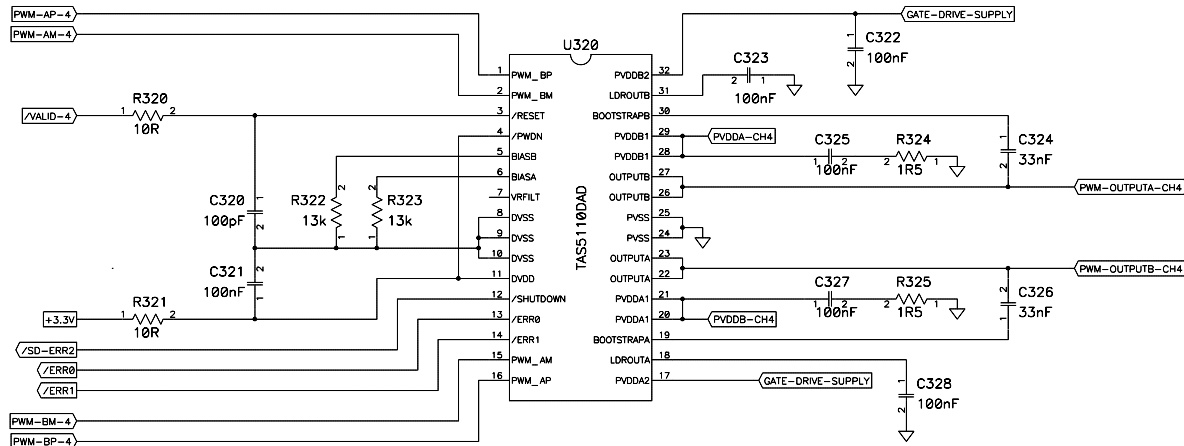

3.4 DEMODULATION FILTER CHANNEL 3

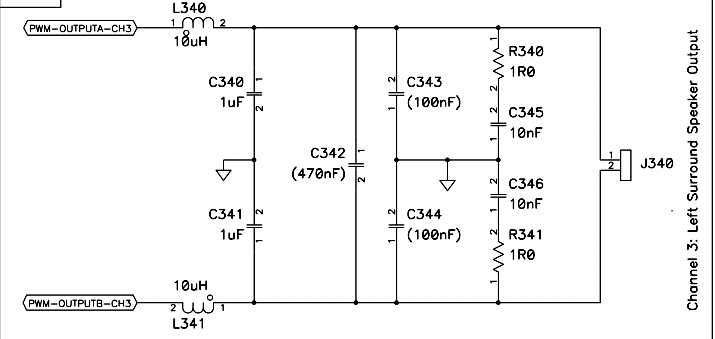

Channel 3: Left Surround Speaker Output

3.6 POWER SUPPLY FILTER

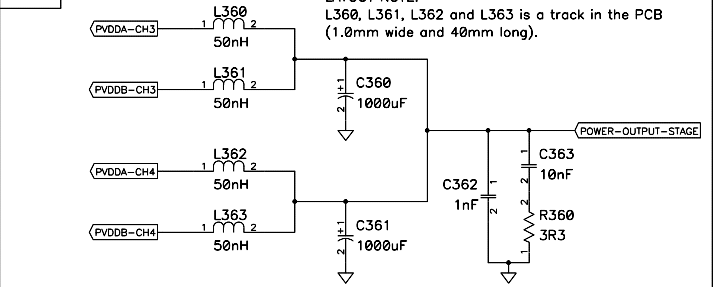

3.8 DEMODULATION FILTER CHANNEL 4

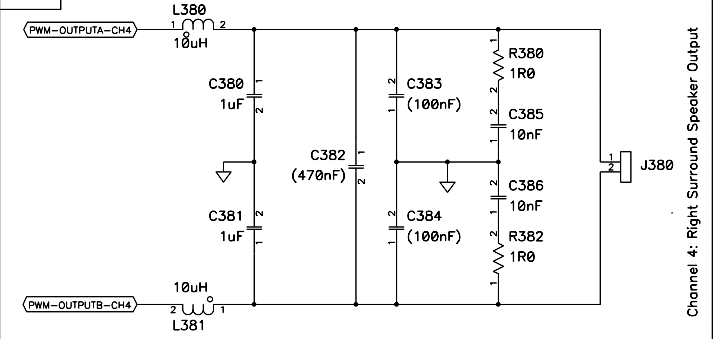

Channel 4: Right Surround Speaker Output

Patents pending in circuitry design and layout (WO99/59241 & WO99/59242).  
This circuitry may only be used together with the integrated circuit TAS5100/TAS5110  
from Texas Instruments Incorporated.

**TEXAS INSTRUMENTS** DIGITAL AUDIO GROUP  
ALL RIGHTS RESERVED - PATENTS PENDING  
TEXAS INSTRUMENTS INCORPORATED

Project:	TAS5110D6REF		
Size: A2	Page Title	Rear Speakers	
Engineers:	Claus Reckweg	Rev:	1.00
Date:	Thu Sep 26, 2002	Mod:	0
Filename:	P167-SCH-001(5.00).sch	Sheet:	3 of 4
File Location:		Drawn by:	CRW

# Center Speaker & Subwoofer

4.0 OUTPUT STAGE CHANNEL 5  
Center Speaker

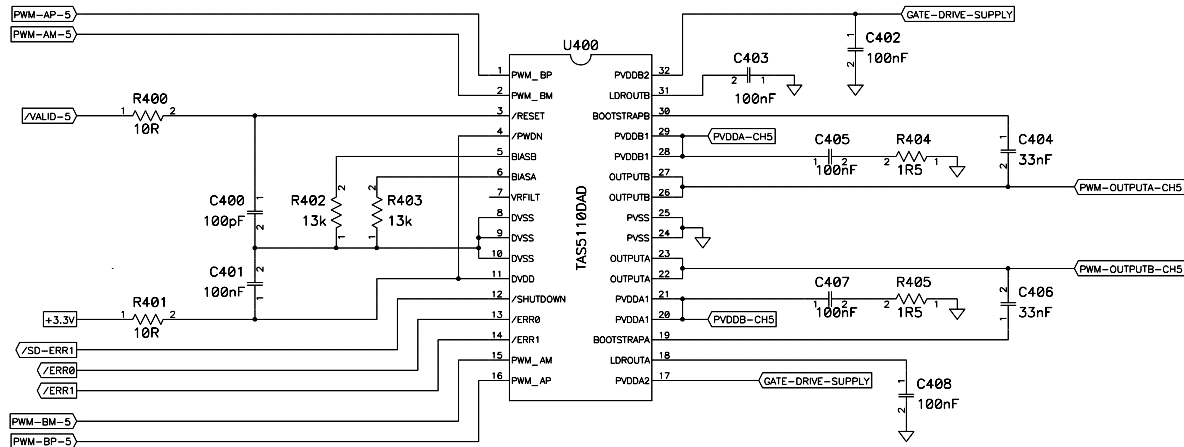

4.2 OUTPUT STAGE CHANNEL 6  
Subwoofer

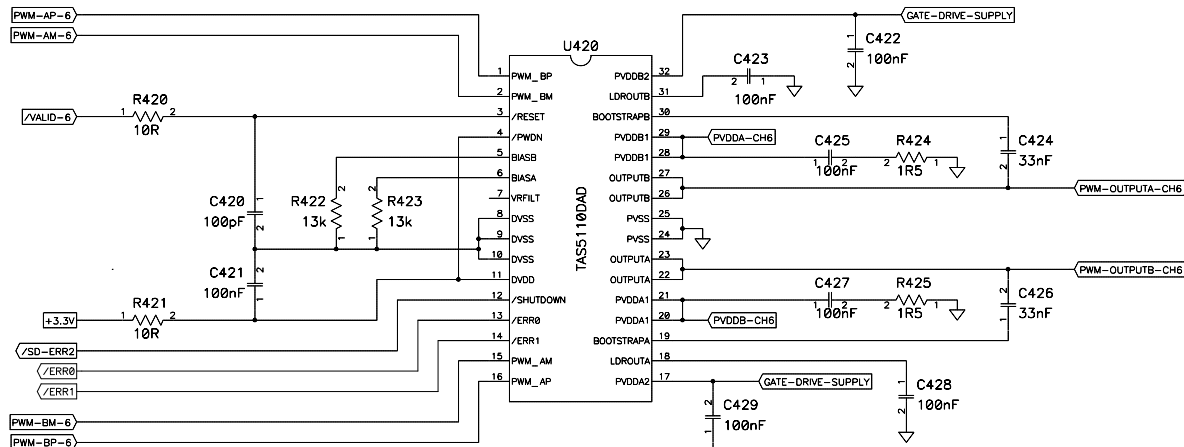

4.4 DEMODULATION FILTER CHANNEL 5

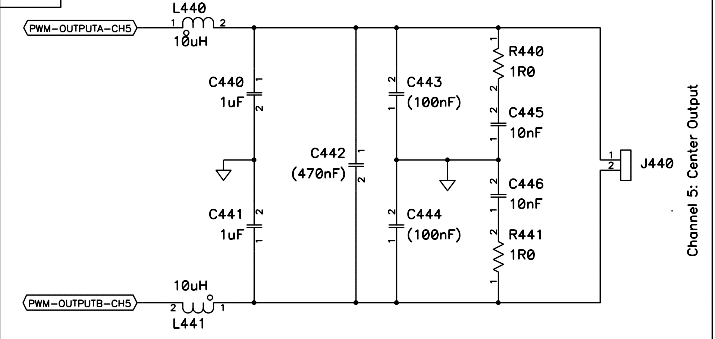

4.6 POWER SUPPLY FILTER

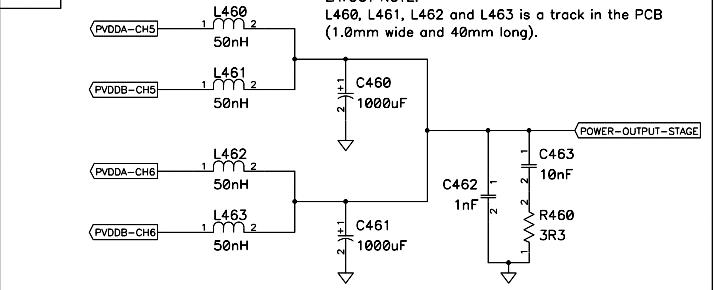

4.8 DEMODULATION FILTER CHANNEL 6

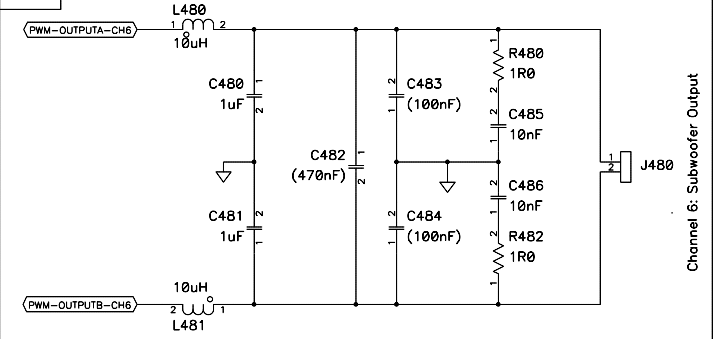

Patents pending in circuitry design and layout (WO99/59241 & WO99/59242).  
This circuitry may only be used together with the integrated circuit TAS5100/TAS5110  
from Texas Instruments Incorporated.

**TEXAS INSTRUMENTS** DIGITAL AUDIO GROUP  
ALL RIGHTS RESERVED - PATENTS PENDING  
TEXAS INSTRUMENTS INCORPORATED

Project: **TAS5110D6REF**

Size: A2 Page Title Center Speaker & Subwoofer

Engineers: Claus Reckweg

Date: Thu Sep 26, 2002 Rev: 1.00 Mod: 0 Sheet: 4 of 4

Filename: P167-SCH-001(5.00).sch Drawn by: CRW

File Location:

Ref Des	Part Number	Description	Housing	Manufacturer	Manufacturer Part Number
R121	100210000	100R 5% 200 ppm 100-mW metalfilm	0603	BC Components	DCT 0603 - 00 5% PA 100R
R122	100210000	100R 5% 200 ppm 100-mW metalfilm	0603	BC Components	DCT 0603 - 00 5% PA 100R
R131	100210000	100R 5% 200 ppm 100-mW metalfilm	0603	BC Components	DCT 0603 - 00 5% PA 100R
R133	100210000	100R 5% 200 ppm 100-mW metalfilm	0603	BC Components	DCT 0603 - 00 5% PA 100R
R140	100210000	100R 5% 200 ppm 100-mW metalfilm	0603	BC Components	DCT 0603 - 00 5% PA 100R
R141	100210000	100R 5% 200 ppm 100-mW metalfilm	0603	BC Components	DCT 0603 - 00 5% PA 100R
R117	100210010	1k00 5% 200 ppm 100-mW metalfilm	0603	BC Components	DCT 0603 - 00 5% PA 1k00
R118	100210010	1k00 5% 200 ppm 100-mW metalfilm	0603	BC Components	DCT 0603 - 00 5% PA 1k00
R124	100210010	1k00 5% 200 ppm 100-mW metalfilm	0603	BC Components	DCT 0603 - 00 5% PA 1k00
R125	100210010	1k00 5% 200 ppm 100-mW metalfilm	0603	BC Components	DCT 0603 - 00 5% PA 1k00
R126	100210010	1k00 5% 200 ppm 100-mW metalfilm	0603	BC Components	DCT 0603 - 00 5% PA 1k00
R130	100210010	1k00 5% 200 ppm 100-mW metalfilm	0603	BC Components	DCT 0603 - 00 5% PA 1k00
R132	100210010	1k00 5% 200 ppm 100-mW metalfilm	0603	BC Components	DCT 0603 - 00 5% PA 1k00
R110	100210020	10k0 5% 200 ppm 100-mW metalfilm	0603	BC Components	DCT 0603 - 00 5% PA 10k0
R111	100210020	10k0 5% 200 ppm 100-mW metalfilm	0603	BC Components	DCT 0603 - 00 5% PA 10k0
R116	100210030	100k 5% 200 ppm 100-mW metalfilm	0603	BC Components	DCT 0603 - 00 5% PA 100k
R170	100210030	100k 5% 200 ppm 100-mW metalfilm	0603	BC Components	DCT 0603 - 00 5% PA 100k
R240	100210080	1R0 5% 300 ppm 100-mW metalfilm	0603	BC Components	DCT 0603 -00 5% PA 1R0
R241	100210080	1R0 5% 300 ppm 100-mW metalfilm	0603	BC Components	DCT 0603 -00 5% PA 1R0
R280	100210080	1R0 5% 300 ppm 100-mW metalfilm	0603	BC Components	DCT 0603 -00 5% PA 1R0
R282	100210080	1R0 5% 300 ppm 100-mW metalfilm	0603	BC Components	DCT 0603 -00 5% PA 1R0
R340	100210080	1R0 5% 300 ppm 100-mW metalfilm	0603	BC Components	DCT 0603 -00 5% PA 1R0
R341	100210080	1R0 5% 300 ppm 100-mW metalfilm	0603	BC Components	DCT 0603 -00 5% PA 1R0
R380	100210080	1R0 5% 300 ppm 100-mW metalfilm	0603	BC Components	DCT 0603 -00 5% PA 1R0
R382	100210080	1R0 5% 300 ppm 100-mW metalfilm	0603	BC Components	DCT 0603 -00 5% PA 1R0
R440	100210080	1R0 5% 300 ppm 100-mW metalfilm	0603	BC Components	DCT 0603 -00 5% PA 1R0
R441	100210080	1R0 5% 300 ppm 100-mW metalfilm	0603	BC Components	DCT 0603 -00 5% PA 1R0
R480	100210080	1R0 5% 300 ppm 100-mW metalfilm	0603	BC Components	DCT 0603 -00 5% PA 1R0
R482	100210080	1R0 5% 300 ppm 100-mW metalfilm	0603	BC Components	DCT 0603 -00 5% PA 1R0
R200	100210090	10R0 5% 200 ppm 100-mW metalfilm	0603	BC Components	DCT 0603 -00 5% PA 10R
R201	100210090	10R0 5% 200 ppm 100-mW metalfilm	0603	BC Components	DCT 0603 -00 5% PA 10R
R220	100210090	10R0 5% 200 ppm 100-mW metalfilm	0603	BC Components	DCT 0603 -00 5% PA 10R
R221	100210090	10R0 5% 200 ppm 100-mW metalfilm	0603	BC Components	DCT 0603 -00 5% PA 10R
R300	100210090	10R0 5% 200 ppm 100-mW metalfilm	0603	BC Components	DCT 0603 -00 5% PA 10R
R301	100210090	10R0 5% 200 ppm 100-mW metalfilm	0603	BC Components	DCT 0603 -00 5% PA 10R
R320	100210090	10R0 5% 200 ppm 100-mW metalfilm	0603	BC Components	DCT 0603 -00 5% PA 10R
R321	100210090	10R0 5% 200 ppm 100-mW metalfilm	0603	BC Components	DCT 0603 -00 5% PA 10R
R400	100210090	10R0 5% 200 ppm 100-mW metalfilm	0603	BC Components	DCT 0603 -00 5% PA 10R
R401	100210090	10R0 5% 200 ppm 100-mW metalfilm	0603	BC Components	DCT 0603 -00 5% PA 10R



Ref Des	Part Number	Description	Housing	Manufacturer	Manufacturer Part Number
R420	100210090	10R0 5% 200 ppm 100-mW metalfilm	0603	BC Components	DCT 0603 -00 5% PA 10R
R421	100210090	10R0 5% 200 ppm 100-mW metalfilm	0603	BC Components	DCT 0603 -00 5% PA 10R
R202	100213020	13k0 5% 200 ppm 100-mW metalfilm	0603	BC Components	DCT 0603 - 00 5% PA 13k0
R203	100213020	13k0 5% 200 ppm 100-mW metalfilm	0603	BC Components	DCT 0603 - 00 5% PA 13k0
R222	100213020	13k0 5% 200 ppm 100-mW metalfilm	0603	BC Components	DCT 0603 - 00 5% PA 13k0
R223	100213020	13k0 5% 200 ppm 100-mW metalfilm	0603	BC Components	DCT 0603 - 00 5% PA 13k0
R302	100213020	13k0 5% 200 ppm 100-mW metalfilm	0603	BC Components	DCT 0603 - 00 5% PA 13k0
R303	100213020	13k0 5% 200 ppm 100-mW metalfilm	0603	BC Components	DCT 0603 - 00 5% PA 13k0
R322	100213020	13k0 5% 200 ppm 100-mW metalfilm	0603	BC Components	DCT 0603 - 00 5% PA 13k0
R323	100213020	13k0 5% 200 ppm 100-mW metalfilm	0603	BC Components	DCT 0603 - 00 5% PA 13k0
R402	100213020	13k0 5% 200 ppm 100-mW metalfilm	0603	BC Components	DCT 0603 - 00 5% PA 13k0
R403	100213020	13k0 5% 200 ppm 100-mW metalfilm	0603	BC Components	DCT 0603 - 00 5% PA 13k0
R422	100213020	13k0 5% 200 ppm 100-mW metalfilm	0603	BC Components	DCT 0603 - 00 5% PA 13k0
R423	100213020	13k0 5% 200 ppm 100-mW metalfilm	0603	BC Components	DCT 0603 - 00 5% PA 13k0
R120	100222000	220R 5% 200 ppm 100-mW metalfilm	0603	BC Components	DCT 0603 -00 5% PA 220R
R114	100222020	22k 5% 200 ppm 100-mW metalfilm	0603	BC Components	DCT 0603 -00 5% PA 22k
R115	100222020	22k 5% 200 ppm 100-mW metalfilm	0603	BC Components	DCT 0603 -00 5% PA 22k
R123	100233000	330R 5% 200 ppm 100-mW	0603	BC Components	DCT 0603 -00 5% PA 330R
R260	100233080	3R30 5% 300 ppm 100-mW metalfilm	0603	BC Components	DCT 0603 -00 5% PA 3R30
R360	100233080	3R30 5% 300 ppm 100-mW metalfilm	0603	BC Components	DCT 0603 -00 5% PA 3R30
R460	100233080	3R30 5% 300 ppm 100-mW metalfilm	0603	BC Components	DCT 0603 -00 5% PA 3R30
R112	100247020	47k0 5% 200 ppm 100-mW metalfilm	0603	BC Components	DCT 0603 -00 5% PA 47k0
R113	100247020	47k0 5% 200 ppm 100-mW metalfilm	0603	BC Components	DCT 0603 -00 5% PA 47k0
R204	100315080	1R50 5% 100 ppm 250-mW metalfilm	RC3715	Beychlag	MMA0204-100 5% BL 1R50
R205	100315080	1R50 5% 100 ppm 250-mW metalfilm	RC3715	Beychlag	MMA0204-100 5% BL 1R50
R224	100315080	1R50 5% 100 ppm 250-mW metalfilm	RC3715	Beychlag	MMA0204-100 5% BL 1R50
R225	100315080	1R50 5% 100 ppm 250-mW metalfilm	RC3715	Beychlag	MMA0204-100 5% BL 1R50
R304	100315080	1R50 5% 100 ppm 250-mW metalfilm	RC3715	Beychlag	MMA0204-100 5% BL 1R50
R305	100315080	1R50 5% 100 ppm 250-mW metalfilm	RC3715	Beychlag	MMA0204-100 5% BL 1R50
R324	100315080	1R50 5% 100 ppm 250-mW metalfilm	RC3715	Beychlag	MMA0204-100 5% BL 1R50
R325	100315080	1R50 5% 100 ppm 250-mW metalfilm	RC3715	Beychlag	MMA0204-100 5% BL 1R50
R404	100315080	1R50 5% 100 ppm 250-mW metalfilm	RC3715	Beychlag	MMA0204-100 5% BL 1R50
R405	100315080	1R50 5% 100 ppm 250-mW metalfilm	RC3715	Beychlag	MMA0204-100 5% BL 1R50
R424	100315080	1R50 5% 100 ppm 250-mW metalfilm	RC3715	Beychlag	MMA0204-100 5% BL 1R50
R425	100315080	1R50 5% 100 ppm 250-mW metalfilm	RC3715	Beychlag	MMA0204-100 5% BL 1R50
C202	200011040	100nF 50V 20% X7R	0805	Philips	2222 580 16741
C203	200011040	100nF 50V 20% X7R	0805	Philips	2222 580 16741
C205	200011040	100nF 50V 20% X7R	0805	Philips	2222 580 16741
C207	200011040	100nF 50V 20% X7R	0805	Philips	2222 580 16741

Ref Des	Part Number	Description	Housing	Manufacturer	Manufacturer Part Number
C208	200011040	100 nF 50 V 20% X7R	0805	Philips	2222 580 16741
C222	200011040	100 nF 50 V 20% X7R	0805	Philips	2222 580 16741
C223	200011040	100 nF 50 V 20% X7R	0805	Philips	2222 580 16741
C225	200011040	100 nF 50 V 20% X7R	0805	Philips	2222 580 16741
C227	200011040	100 nF 50 V 20% X7R	0805	Philips	2222 580 16741
C302	200011040	100 nF 50 V 20% X7R	0805	Philips	2222 580 16741
C303	200011040	100 nF 50 V 20% X7R	0805	Philips	2222 580 16741
C305	200011040	100 nF 50 V 20% X7R	0805	Philips	2222 580 16741
C307	200011040	100 nF 50 V 20% X7R	0805	Philips	2222 580 16741
C308	200011040	100 nF 50 V 20% X7R	0805	Philips	2222 580 16741
C322	200011040	100 nF 50 V 20% X7R	0805	Philips	2222 580 16741
C323	200011040	100 nF 50 V 20% X7R	0805	Philips	2222 580 16741
C325	200011040	100 nF 50 V 20% X7R	0805	Philips	2222 580 16741
C327	200011040	100 nF 50 V 20% X7R	0805	Philips	2222 580 16741
C328	200011040	100 nF 50 V 20% X7R	0805	Philips	2222 580 16741
C402	200011040	100 nF 50 V 20% X7R	0805	Philips	2222 580 16741
C403	200011040	100 nF 50 V 20% X7R	0805	Philips	2222 580 16741
C405	200011040	100 nF 50 V 20% X7R	0805	Philips	2222 580 16741
C407	200011040	100 nF 50 V 20% X7R	0805	Philips	2222 580 16741
C408	200011040	100 nF 50 V 20% X7R	0805	Philips	2222 580 16741
C422	200011040	100 nF 50 V 20% X7R	0805	Philips	2222 580 16741
C423	200011040	100 nF 50 V 20% X7R	0805	Philips	2222 580 16741
C425	200011040	100 nF 50 V 20% X7R	0805	Philips	2222 580 16741
C427	200011040	100 nF 50 V 20% X7R	0805	Philips	2222 580 16741
C428	200011040	100 nF 50 V 20% X7R	0805	Philips	2222 580 16741
C429	200011040	100 nF 50 V 20% X7R	0805	Philips	2222 580 16741
R228	200011040	100 nF 50 V 20% X7R	0805	Philips	2222 580 16741
C204	200023330	33 nF 100 V 20% X7R	1206	Philips	2222 601 16743
C206	200023330	33 nF 100 V 20% X7R	1206	Philips	2222 601 16743
C224	200023330	33 nF 100 V 20% X7R	1206	Philips	2222 601 16743
C226	200023330	33 nF 100 V 20% X7R	1206	Philips	2222 601 16743
C304	200023330	33 nF 100 V 20% X7R	1206	Philips	2222 601 16743
C306	200023330	33 nF 100 V 20% X7R	1206	Philips	2222 601 16743
C324	200023330	33 nF 100 V 20% X7R	1206	Philips	2222 601 16743
C326	200023330	33 nF 100 V 20% X7R	1206	Philips	2222 601 16743
C404	200023330	33 nF 100 V 20% X7R	1206	Philips	2222 601 16743
C406	200023330	33 nF 100 V 20% X7R	1206	Philips	2222 601 16743
C424	200023330	33 nF 100 V 20% X7R	1206	Philips	2222 601 16743
C426	200023330	33 nF 100 V 20% X7R	1206	Philips	2222 601 16743

Ref Des	Part Number	Description	Housing	Manufacturer	Manufacturer Part Number
C100	200041060	10 uF 16 V 20% LYT	LY4x5SMD	Panasonic	ECE V 1C A 100 SR
C101	200041060	10 uF 16 V 20% LYT	LY4x5SMD	Panasonic	ECE V 1C A 100 SR
C115	200041060	10 uF 16 V 20% LYT	LY4x5SMD	Panasonic	ECE V 1C A 100 SR
C117	200041060	10 uF 16 V 20% LYT	LY4x5SMD	Panasonic	ECE V 1C A 100 SR
C170	200041060	10 uF 16 V 20% LYT	LY4x5SMD	Panasonic	ECE V 1C A 100 SR
C172	200041060	10 uF 16 V 20% LYT	LY4x5SMD	Panasonic	ECE V 1C A 100 SR
C150	200044750	4.7 uF 35 V 20% 105°C 8R	LY4x5SMD	Philips	BCC2222-153-60478
C245	200051030	10 nF 50 V 20% X7R	0603	KEMET	C0603C103M5RAC
C246	200051030	10 nF 50 V 20% X7R	0603	KEMET	C0603C103M5RAC
C263	200051030	10 nF 50 V 20% X7R	0603	KEMET	C0603C103M5RAC
C285	200051030	10 nF 50 V 20% X7R	0603	KEMET	C0603C103M5RAC
C286	200051030	10 nF 50 V 20% X7R	0603	KEMET	C0603C103M5RAC
C345	200051030	10 nF 50 V 20% X7R	0603	KEMET	C0603C103M5RAC
C346	200051030	10 nF 50 V 20% X7R	0603	KEMET	C0603C103M5RAC
C363	200051030	10 nF 50 V 20% X7R	0603	KEMET	C0603C103M5RAC
C385	200051030	10 nF 50 V 20% X7R	0603	KEMET	C0603C103M5RAC
C386	200051030	10 nF 50 V 20% X7R	0603	KEMET	C0603C103M5RAC
C445	200051030	10 nF 50 V 20% X7R	0603	KEMET	C0603C103M5RAC
C446	200051030	10 nF 50 V 20% X7R	0603	KEMET	C0603C103M5RAC
C463	200051030	10 nF 50 V 20% X7R	0603	KEMET	C0603C103M5RAC
C485	200051030	10 nF 50 V 20% X7R	0603	KEMET	C0603C103M5RAC
C486	200051030	10 nF 50 V 20% X7R	0603	KEMET	C0603C103M5RAC
C114	200051040	100 nF 16 V 20% X7R	0603	KEMET	C0603C104M4RAC
C116	200051040	100 nF 16 V 20% X7R	0603	KEMET	C0603C104M4RAC
C171	200051040	100 nF 16 V 20% X7R	0603	KEMET	C0603C104M4RAC
C173	200051040	100 nF 16 V 20% X7R	0603	KEMET	C0603C104M4RAC
C201	200051040	100 nF 16 V 20% X7R	0603	KEMET	C0603C104M4RAC
C221	200051040	100 nF 16 V 20% X7R	0603	KEMET	C0603C104M4RAC
C301	200051040	100 nF 16 V 20% X7R	0603	KEMET	C0603C104M4RAC
C321	200051040	100 nF 16 V 20% X7R	0603	KEMET	C0603C104M4RAC
C401	200051040	100 nF 16 V 20% X7R	0603	KEMET	C0603C104M4RAC
C421	200051040	100 nF 16 V 20% X7R	0603	KEMET	C0603C104M4RAC
C110	200052230	22 nF 50 V 20% X7R	0603	KEMET	C0603C223M3RAC
C111	200052230	22 nF 50 V 20% X7R	0603	KEMET	C0603C223M3RAC
C112	200054730	47 nF 16 V 20% X7R	0603	KEMET	C0603C473M2RAC
C113	200054730	47 nF 16 V 20% X7R	0603	KEMET	C0603C473M2RAC
C200	200061010	100 pF 50 V 10% NPO	0603	KEMET	C0603C101K5GAC
C220	200061010	100 pF 50 V 10% NPO	0603	KEMET	C0603C101K5GAC
C300	200061010	100 pF 50 V 10% NPO	0603	KEMET	C0603C101K5GAC

Ref Des	Part Number	Description	Housing	Manufacturer	Manufacturer Part Number
C320	200061010	100 pF 50 V 10% NPO	0603	KEMET	C0603C101K5GAC
C400	200061010	100 pF 50 V 10% NPO	0603	KEMET	C0603C101K5GAC
C420	200061010	100 pF 50 V 10% NPO	0603	KEMET	C0603C101K5GAC
C130	200061020	1 nF 10% 50 V NPO	0603	KEMET	C0603C102K5GAC
C131	200061020	1 nF 10% 50 V NPO	0603	KEMET	C0603C102K5GAC
C140	200061020	1 nF 10% 50 V NPO	0603	KEMET	C0603C102K5GAC
C141	200061020	1 nF 10% 50 V NPO	0603	KEMET	C0603C102K5GAC
C262	200061020	1 nF 10% 50 V NPO	0603	KEMET	C0603C102K5GAC
C362	200061020	1 nF 10% 50 V NPO	0603	KEMET	C0603C102K5GAC
C462	200061020	1 nF 10% 50 V NPO	0603	KEMET	C0603C102K5GAC
C260	250041081	1000 uF 35 V 20% low ESR	C7M5PD18	Panasonic	EEUFC1V102
C261	250041081	1000 uF 35 V 20% low ESR	C7M5PD18	Panasonic	EEUFC1V102
C360	250041081	1000 uF 35 V 20% low ESR	C7M5PD18	Panasonic	EEUFC1V102
C361	250041081	1000 uF 35 V 20% low ESR	C7M5PD18	Panasonic	EEUFC1V102
C460	250041081	1000 uF 35 V 20% low ESR	C7M5PD18	Panasonic	EEUFC1V102
C461	250041081	1000 uF 35 V 20% low ESR	C7M5PD18	Panasonic	EEUFC1V102
C240	270021051	1 uF 63 V 10% polyester	C3B2	Wima	MKS4 1uF 63V 10% PCM7.5
C241	270021051	1 uF 63 V 10% polyester	C3B2	Wima	MKS4 1uF 63V 10% PCM7.5
C280	270021051	1 uF 63 V 10% polyester	C3B2	Wima	MKS4 1uF 63V 10% PCM7.5
C281	270021051	1 uF 63 V 10% polyester	C3B2	Wima	MKS4 1uF 63V 10% PCM7.5
C340	270021051	1 uF 63 V 10% polyester	C3B2	Wima	MKS4 1uF 63V 10% PCM7.5
C341	270021051	1 uF 63 V 10% polyester	C3B2	Wima	MKS4 1uF 63V 10% PCM7.5
C380	270021051	1 uF 63 V 10% polyester	C3B2	Wima	MKS4 1uF 63V 10% PCM7.5
C381	270021051	1 uF 63 V 10% polyester	C3B2	Wima	MKS4 1uF 63V 10% PCM7.5
C440	270021051	1 uF 63 V 10% polyester	C3B2	Wima	MKS4 1uF 63V 10% PCM7.5
C441	270021051	1 uF 63 V 10% polyester	C3B2	Wima	MKS4 1uF 63V 10% PCM7.5
C480	270021051	1 uF 63 V 10% polyester	C3B2	Wima	MKS4 1uF 63V 10% PCM7.5
C481	270021051	1 uF 63 V 10% polyester	C3B2	Wima	MKS4 1uF 63V 10% PCM7.5
L240	350101031	10uH 8A 10% 28mR		TOKIN	SBPSC-11R310-100A
L241	350101031	10uH 8A 10% 28mR		TOKIN	SBPSC-11R310-100A
L280	350101031	10uH 8A 10% 28mR		TOKIN	SBPSC-11R310-100A
L281	350101031	10uH 8A 10% 28mR		TOKIN	SBPSC-11R310-100A
L340	350101031	10uH 8A 10% 28mR		TOKIN	SBPSC-11R310-100A
L341	350101031	10uH 8A 10% 28mR		TOKIN	SBPSC-11R310-100A
L380	350101031	10uH 8A 10% 28mR		TOKIN	SBPSC-11R310-100A
L381	350101031	10uH 8A 10% 28mR		TOKIN	SBPSC-11R310-100A
L440	350101031	10uH 8A 10% 28mR		TOKIN	SBPSC-11R310-100A
L441	350101031	10uH 8A 10% 28mR		TOKIN	SBPSC-11R310-100A
L480	350101031	10uH 8A 10% 28mR		TOKIN	SBPSC-11R310-100A

Ref Des	Part Number	Description	Housing	Manufacturer	Manufacturer Part Number
L481	350101031	10uH 8A 10% 28mR		TOKIN	SBPSC-11R310-100A
LED121	405000810	RED 10mA LED SMD	0603P	Toshiba	TLSU1008
LED122	405000810	RED 10mA LED SMD	0603P	Toshiba	TLSU1008
LED123	405000820	GREEN 10mA LED SMD	0603P	Toshiba	TLGU1008
LED120	405000830	YELLOW 10mA LED SMD	0603P	Toshiba	TLYU1008
Q120	425229070	PNP 40V/800 mA small signal transistor	SOT-23	Fairchild	MMBT2907A
Q121	425229070	PNP 40V/800 mA small signal transistor	SOT-23	Fairchild	MMBT2907A
Q122	425229070	PNP 40V/800 mA small signal transistor	SOT-23	Fairchild	MMBT2907A
U200	500051101	TDAA PWM Power Output Stage, DAD package	HTSSOP32	Texas Instruments	TAS5110DAD
U220	500051101	TDAA PWM Power Output Stage, DAD package	HTSSOP32	Texas Instruments	TAS5110DAD
U300	500051101	TDAA PWM Power Output Stage, DAD package	HTSSOP32	Texas Instruments	TAS5110DAD
U320	500051101	TDAA PWM Power Output Stage, DAD package	HTSSOP32	Texas Instruments	TAS5110DAD
U400	500051101	TDAA PWM Power Output Stage, DAD package	HTSSOP32	Texas Instruments	TAS5110DAD
U420	500051101	TDAA PWM Power Output Stage, DAD package	HTSSOP32	Texas Instruments	TAS5110DAD
U111	510102721	Dual RtR Output OPAMP	MSOP8	Texas Instruments	TLV272CDGK
U110	520141261	Dual buffer with output enable, LVC	MSOP8	Texas Instruments	SN74LVC2G126DCT
U130	520141261	Dual buffer with output enable, LVC	MSOP8	Texas Instruments	SN74LVC2G126DCT
U140	520141261	Dual buffer with output enable, LVC	MSOP8	Texas Instruments	SN74LVC2G126DCT
U170	540251330	3.3 V/1.5A low drop Lin. Reg.	HTSSOP20	Texas Instruments	TPS75333QPWP
MECH1	600100050	P167-MECH-002 (1.00)		GTV	P167-MECH-002 (1.00)
MECH2	600100060	P167-MECH-003 (1.00)		GTV	P167-MECH-003 (1.00)
MECH2	600100070	P167-MECH-004 (1.00)		GTV	P167-MECH-004 (1.00)
SCREW01	600200010	M3x6 Pozidriv stainless steel screw		Bossard	BN 31108 M3x6
SCREW02	600200010	M3x6 Pozidriv stainless steel screw		Bossard	BN 31108 M3x6
SCREW03	600200010	M3x6 Pozidriv stainless steel screw		Bossard	BN 31108 M3x6
SCREW04	600200020	M3x10 Pozidriv stainless steel screw		Bossard	BN 31108 M3x10
SCREW05	600200020	M3x10 Pozidriv stainless steel screw		Bossard	BN 31108 M3x10
SCREW06	600200020	M3x10 Pozidriv stainless steel screw		Bossard	BN 31108 M3x10
WASHER01	600400010	M3 stainless steel washer		Bossard	BN 670
WASHER02	600400010	M3 stainless steel washer		Bossard	BN 670
WASHER03	600400010	M3 stainless steel washer		Bossard	BN 670
WASHER04	600400010	M3 stainless steel washer		Bossard	BN 670
WASHER05	600400010	M3 stainless steel washer		Bossard	BN 670
WASHER06	600400010	M3 stainless steel washer		Bossard	BN 670
J110	700100021	2 pin 2,54 mm pitch header, friction lock	MX2SI	Molex	22-27-2021
J160	700100051	5 pin 2,54 mm pitch header, friction lock	MX5SI	Molex	22-27-2051
J240	700300020	2 Pin 3,96 mm pitch header	MY2S	JST	B 2P-VH
J280	700300020	2 Pin 3,96 mm pitch header	MY2S	JST	B 2P-VH
J340	700300020	2 Pin 3,96 mm pitch header	MY2S	JST	B 2P-VH

Ref Des	Part Number	Description	Housing	Manufacturer	Manufacturer Part Number
J380	700300020	2 pin 3,96 mm pitch header	MY2S	JST	B 2P-VH
J440	700300020	2 pin 3,96 mm pitch header	MY2S	JST	B 2P-VH
J480	700300020	2 pin 3,96 mm pitch header	MY2S	JST	B 2P-VH
J150	700300040	4 pin 3,96 mm pitch header	MY4S	JST	B 4P-VH
J100	700820500	Box header straight 50 pin 2,54 mm	IDC50	Multicomp	MC9A12-5034
PCB	900116710	P167-PCB-001(1.00)		Printline	P167-PCB-001(1.00)
C132	Deleted	Deleted			
C133	Deleted	Deleted			
C134	Deleted	Deleted			
C209	Deleted	Deleted			
C229	Deleted	Deleted			
C309	Deleted	Deleted			
C329	Deleted	Deleted			
C409	Deleted	Deleted			
C242	Not used	Not used			
C243	Not used	Not used			
C244	Not used	Not used			
C282	Not used	Not used			
C283	Not used	Not used			
C284	Not used	Not used			
C342	Not used	Not used			
C343	Not used	Not used			
C344	Not used	Not used			
C382	Not used	Not used			
C383	Not used	Not used			
C384	Not used	Not used			
C442	Not used	Not used			
C443	Not used	Not used			
C444	Not used	Not used			
C482	Not used	Not used			
C483	Not used	Not used			
C484	Not used	Not used			
J101	Not used	Not used			
J102	Not used	Not used			
R261	Not used	Not used			
R262	Not used	Not used			
L260	Trace	A trace in the PCB			
L261	Trace	A trace in the PCB			
L262	Trace	A trace in the PCB			

Ref Des	Part Number	Description	Housing	Manufacturer	Manufacturer Part Number
L263	Trace	A trace in the PCB			
L360	Trace	A trace in the PCB			
L361	Trace	A trace in the PCB			
L362	Trace	A trace in the PCB			
L363	Trace	A trace in the PCB			
L460	Trace	A trace in the PCB			
L461	Trace	A trace in the PCB			
L462	Trace	A trace in the PCB			
L463	Trace	A trace in the PCB			

---

# TAS5110D6REF PCB SPECIFICATION

---

BOARD IDENTIFICATION:	P167-PCB-001 (1.00)
BOARD TYPE:	Double-sided plated-through board
LAMINATE TYPE:	FR4
LAMINATE THICKNESS:	1,6 mm
COPPER THICKNESS:	70 $\mu\text{m}$ (including plating exterior layer)
COPPER PLATING OF HOLES:	>25 $\mu\text{m}$
MINIMUM HOLE DIAMETER	0,3 mm
SILKSCREEN COMPONENT SIDE:	White-remove silkscreen from solder area and pretinned areas
SILKSCREEN SOLDER SIDE:	None
SOLDER MASK COMPONENT SIDE:	Green
SOLDER MASK SOLDER SIDE:	Green
PROTECTIVE COATING:	Solder coating and chemical silver on free copper
ELECTRICAL TEST:	PCB must be electrical tested
MANUFACTURED TO:	PERFAG 2E ( <a href="http://www.perfag.dk">www.perfag.dk</a> )
APERTURE TABLE:	PERFAG 10A ( <a href="http://www.perfag.dk">www.perfag.dk</a> )
BOARD SIZE:	105 x 127 mm

---



COMP. LAYOUT COMP	DpS 4800 020306
TI Copenhagen P167-PCB-001 (1.00)	

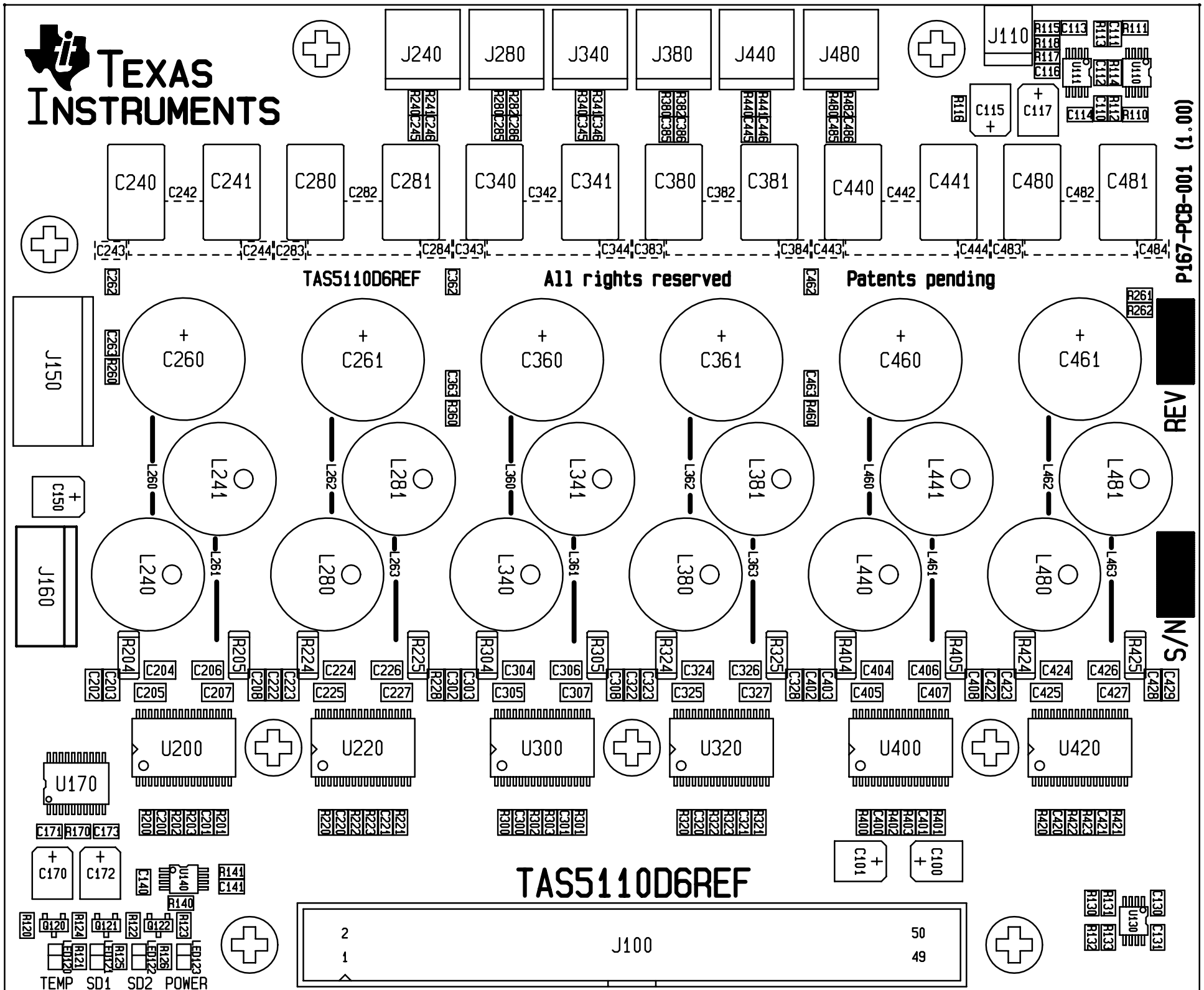

COMPONENT SIDE	DpS 4800 020306
TI Copenhagen P167-PCB-001 (1.00)	

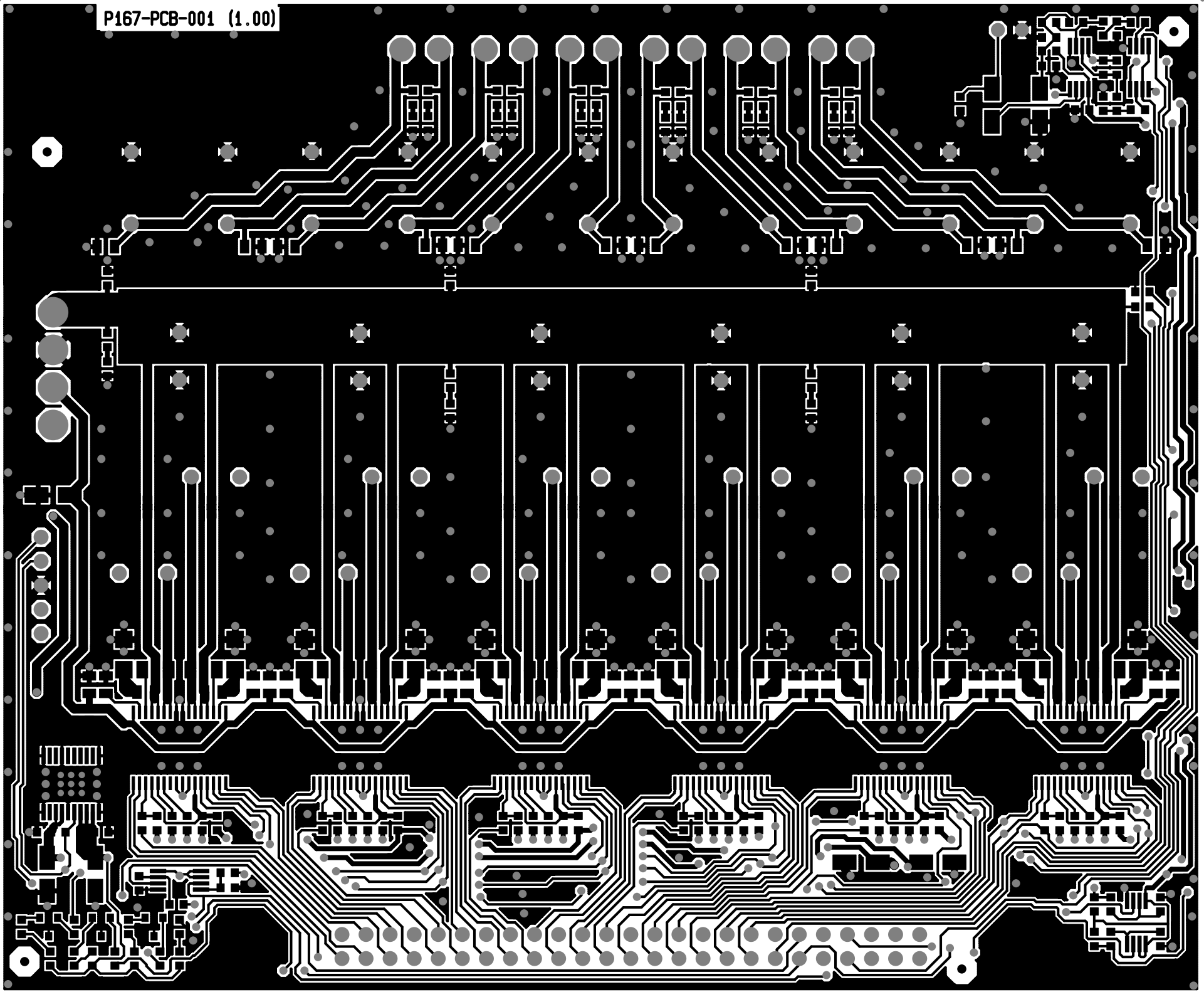

203050 008A 2q0	2012 R30J02
(00.1) 100-8C9-7219	TI Coprnhagen P1E7-PCB-001 (1.00)

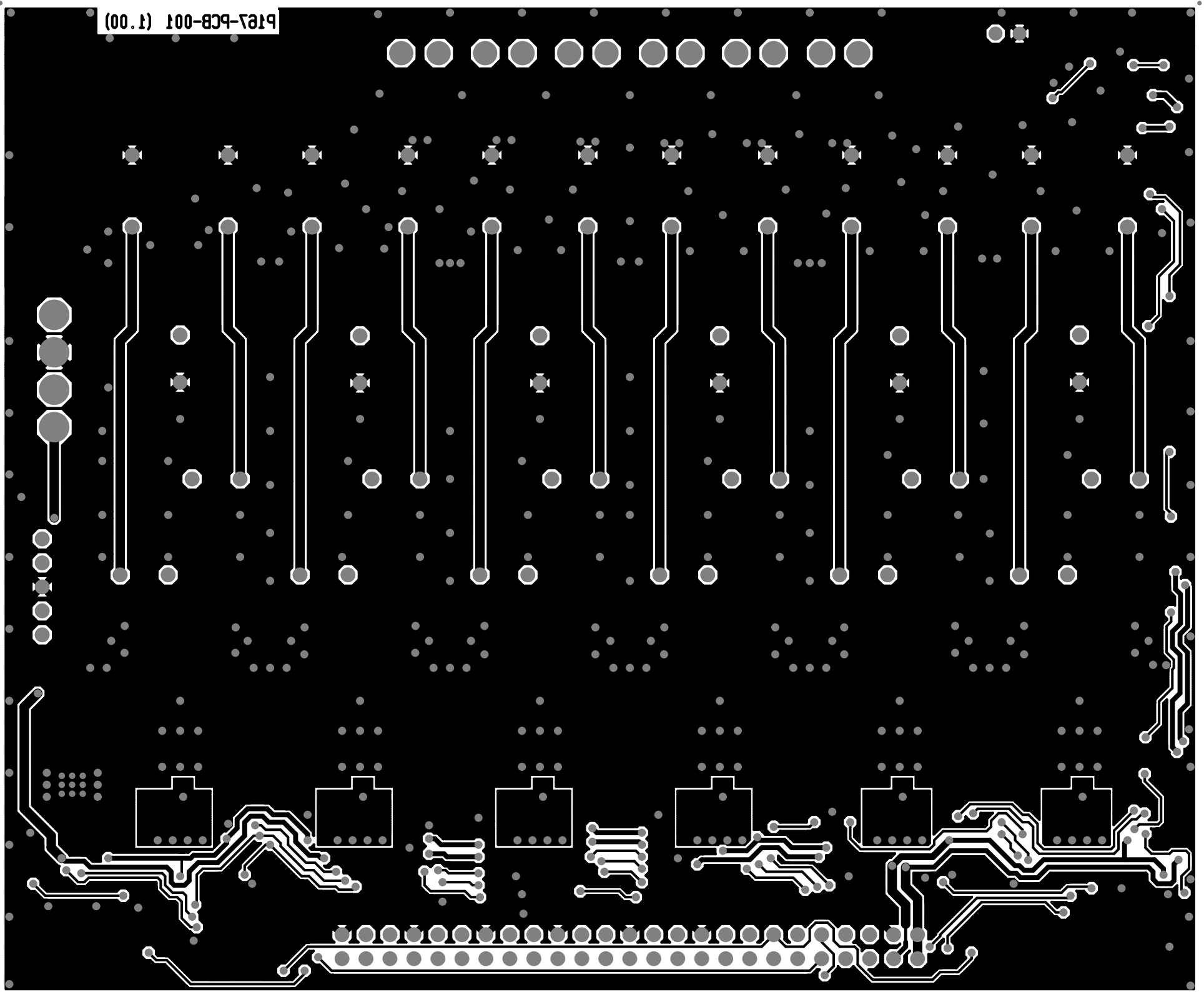

P1E7-PCB-001 (1.00)

SILKSCREEN COMP	Dps 4800 020306
TI Copenhagen P167-PCB-001 (1.00)	

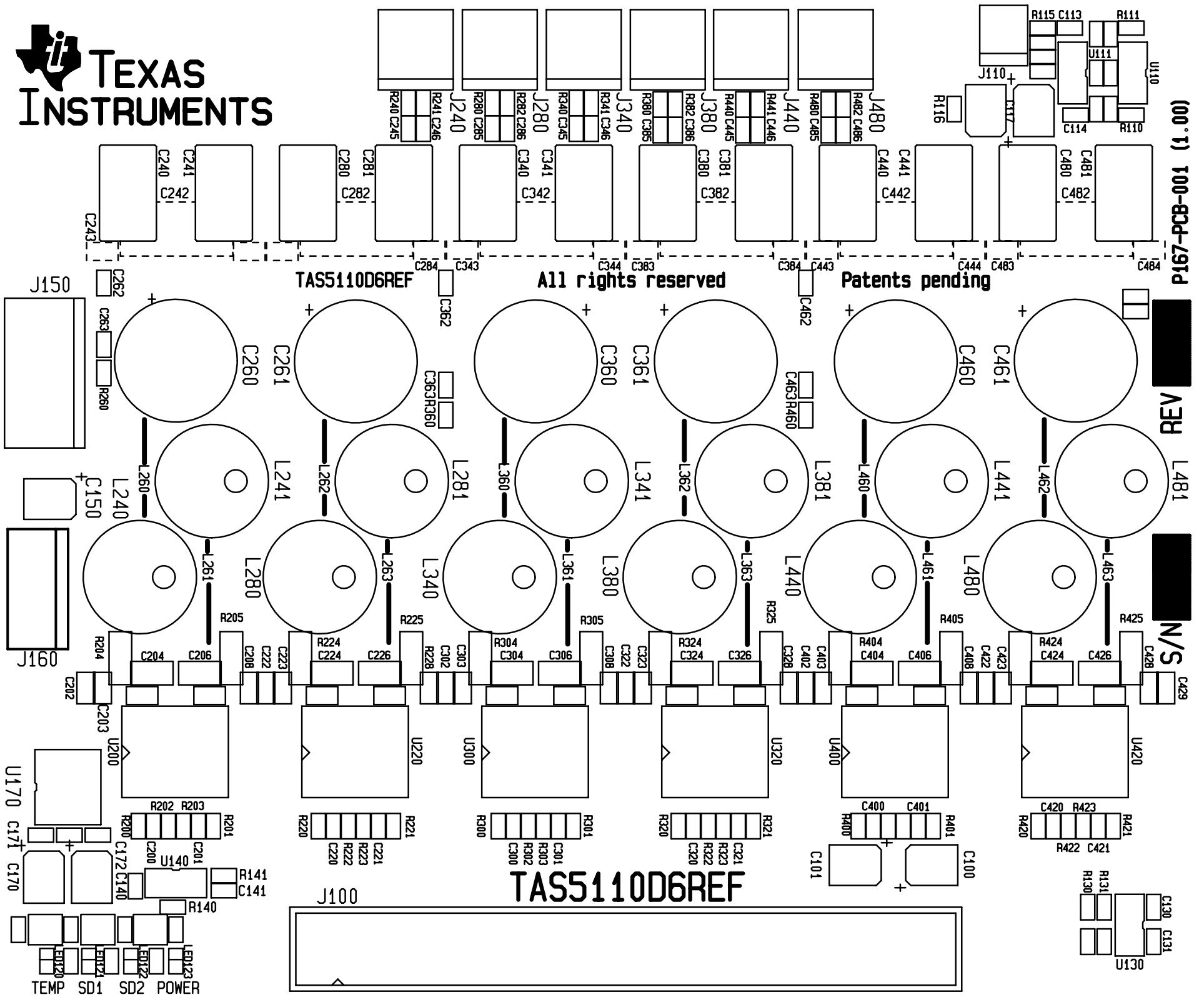

DRILL INFORMATION	Dps 4800 020306
TI Copenhagen P167-PCB-001 (1.00)	

- ✦ T1 VH DIA = 0.3 QTY = 9
- ◻ T2 VH DIA = 0.5 QTY = 461
- ▲ T3 PTH DIA = 1 QTY = 117
- ◻ T4 PTH DIA = 1.5 QTY = 16
- ▽ T5 PTH DIA = 3.3 QTY = 8
- ⊞ T6 NP DIA = 0.05 QTY = 4

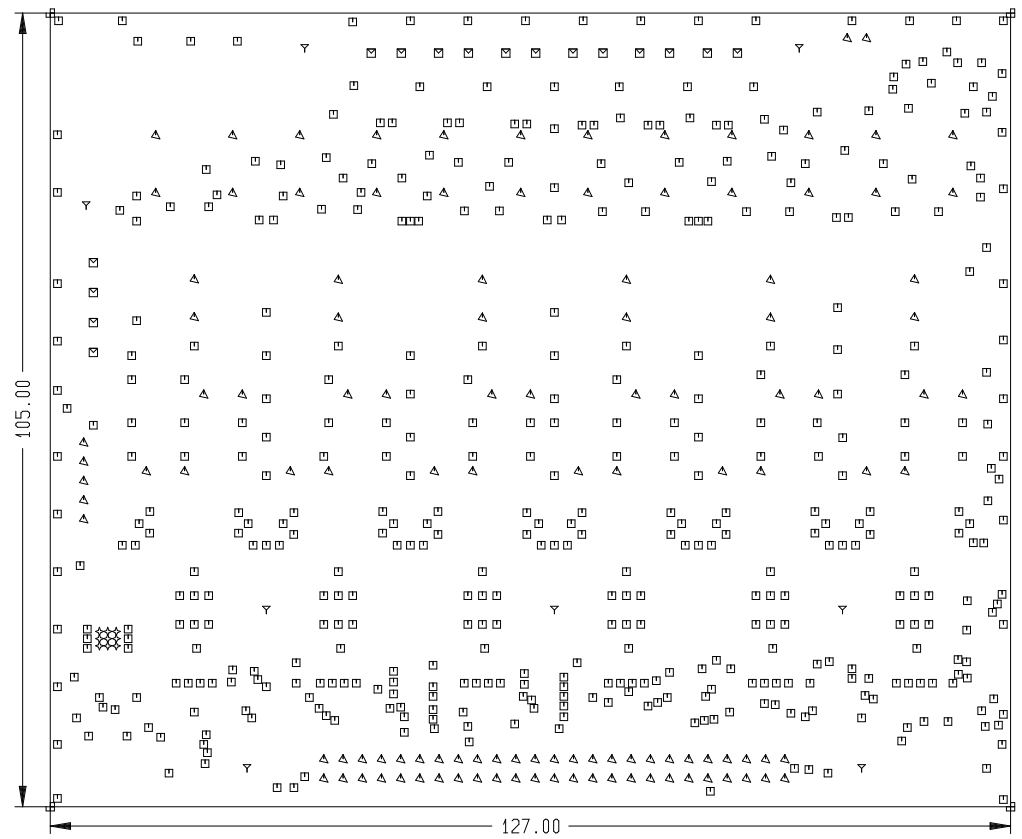

\*\*\*DRILL CODE\*\*\*

## Free Manuals Download Website

<http://myh66.com>

<http://usermanuals.us>

<http://www.somanuals.com>

<http://www.4manuals.cc>

<http://www.manual-lib.com>

<http://www.404manual.com>

<http://www.luxmanual.com>

<http://aubethermostatmanual.com>

Golf course search by state

<http://golfingnear.com>

Email search by domain

<http://emailbydomain.com>

Auto manuals search

<http://auto.somanuals.com>

TV manuals search

<http://tv.somanuals.com>