



## Ultra-Aire 135H Whole House Ventilating Dehumidifier

UA-135H • Part No. 4025470 • Serial No. \_\_\_\_\_



### Dehumidification

The highly efficient Ultra-Aire 135H dehumidifier utilizes refrigeration to cool the incoming air stream below its dew point. This cooled and drier air is used to pre-cool the incoming air stream resulting in a significant increase in overall efficiency. After the pre-cooling stage, the processed air is reheated by passing through the condenser coil. The heat removed by the evaporator coil is returned to the air stream, resulting in an overall temperature increase of the air leaving the unit.

The Ultra-Aire 135H is controlled by 24 volt remote wired controls. A variety of controls are available suitable to various applications.

### Fresh Air Ventilation

Optional fresh outdoor air may be ducted to the unit via a six inch round duct. This provides fresh air to dilute pollutants and maintain high oxygen content in the air. The amount of fresh air ventilation can be regulated by a variety of dampers and controls.

### Air Filtration

The Ultra-Aire 135H includes air filtration to improve indoor air quality. A MERV-11 media filter is standard. An optional MERV-14 deep pleated 95% media filter is available for optimum air filtration and to reduce potentially harmful airborne particles. If the optional filter is chosen, the standard filter operates as a prefilter.

**HVAC INSTALLER: PLEASE LEAVE MANUAL FOR HOMEOWNER**

# TABLE OF CONTENTS /SAFETY PRECAUTIONS & SPECIFICATIONS

## Table of Contents

Safety Precautions.....	3	4.7F DEH 2000 Digital Controller Without Fresh Air .....	8
1.Intended Application .....	4	4.8 Humidity Control Adjustment .....	8
2.Registrations .....	4	4.9 Fan/Filter Switch.....	8
3.Specifications .....	4	4.10 Ventilation Timer.....	8
4. Installation .....	4	4.11 Setting the Time .....	9
4.1 Installation Checklist.....	4	4.12 Ventilation Schedule .....	9
4.1A Drainage & Trap .....	4	4.13 Automatic or Manual Mode.....	9
4.1B Filter Box & Fresh Air Ventilation .....	4	Installer Diagram .....	10
4.1C Power Accessibility.....	4	5. DEH 2000 Digital Control .....	11
4.1D Space.....	4	5.1 Specifications.....	11
4.1E Low Voltage Wiring .....	4	5.2 Installation.....	11
4.1F Sound.....	4	5.2A Install Instructions .....	11
4.1G Back-Draft Damper .....	4	5.2B Wiring.....	11
4.1H Support Structure and Suspension .....	4	5.2C Location .....	12
4.2 External Insulation Kit .....	4	5.3 Operation .....	12
4.3 Electrical Requirements.....	5	5.3A Display .....	12
4.4 Condensate Removal.....	5	5.3B Setting .....	12
4.4A Lifting Condensate .....	5	5.3C On/Off Setting .....	12
4.5 Ducting.....	5	5.3D Setting Clock Time .....	12
4.5A Installing Duct Collars.....	5	5.3E Setting Relative Humidity Setpoint.....	13
4.5B Ducting for Dehumidification .....	5	5.3F Fan Setting and Operation .....	13
4.5C Ducting for Fresh Air.....	5	5.3F Fan On Fan Off Fan Program.....	13
4.5D Ducting for Fresh Air - Option .....	6	5.3H Damper Operation and Setting .....	13
4.5E Installation in a Basement or Crawl Space		5.3I Intermittent/Programmed Ventilation.....	14
with an Existing Forced Air HVAC System.....	6	5.3J Programming Notes.....	14
4.5F Installation in an Attic with an		5.3K Ventilating or Dehumidifying to	
Existing Forced Air HVAC System .....	7	Control Indoor Relative Humidity Levels .....	14
4.5G Installation in a Structure with		5.3L Stop Start .....	14
Two Forced Air HVAC Systems .....	7	5.4 Low Pressure Control .....	14
4.5H Installation in a Structure with No		6. Service .....	15
Existing Forced Air HVAC System .....	7	6.1 Technical Description.....	15
4.6 Compressor Release and Noise Abatement.....	7	6.2 Troubleshooting .....	15
4.7 Controls.....	7	6.3 Refrigerant Cleaning .....	16
4.7A Humidity/Fan Control Panel Without		6.4 Impeller Fan Replacement .....	16
Fresh Air Ventilation or Damper.....	8	6.5 Compressor/Capacitor Replacement.....	16
4.7B Humidity/Fan Control Panel		6.6 Replacing a Compressor, Nonburn Out.....	16
With Fresh Air Ventilation and Without Damper .....	8	6.7 Electric Ventilation Damper .....	16
4.7D Humidity/Fan Control Panel		6.8 Condensate Pump Kit.....	16
With Fresh Air Ventilation and Damper .....	8	Wiring Diagram.....	17
4.7D Ventilation Timer and Humidity Control		Optional Parts List.....	18
With Fresh Air AND Motorized Damper .....	8	Service Parts List.....	19
4.7E DEH 2000 Digital Controller		Warranty.....	20
WITH Fresh Air and Damper.....	8		

# SAFETY PRECAUTIONS

## Safety Precautions

Read the installation, operation and maintenance instructions carefully before installing and operating this device. Proper adherence to these instructions is essential to obtain maximum benefit from your UA-135H indoor air quality system.

### READ AND SAVE THESE INSTRUCTIONS

- The device is designed to be installed **INDOORS IN A SPACE THAT IS PROTECTED FROM RAIN AND FLOODING.**
- Install the unit with space to access the front panel for maintenance and service. **DO NOT INSTALL UNIT WITH THE FRONT PANEL INACCESSIBLE.**
- Avoid directing the discharge air at people, or over the water in pool areas.
- If used near a pool or spa; be certain there is **NO** chance the unit could fall into the water, splashed and that it is plugged into a **GFCI GROUND FAULT CIRCUIT INTERRUPT OUTLET.**
- **DO NOT** use the device as a bench or table.
- **DO NOT** place the device directly on structural members.
- A drain pan **MUST** be placed under the unit if installed above a living area or above an area where water leakage could cause damage.

## 1. Intended Application for Ultra-Aire 135H

For the ideal installation, draw air from the central part of the home and return it to the isolated areas of the home like the bedrooms, den, utility room, or family room. The ductwork of the existing heating system can be used to supply air to the home.

## 2. Registrations

The Ultra-Aire 135H (P/N 4025080) conforms to UL STD 1995. Certified to CAN/CSA STD C22.2 No. 236.

## 3. Specifications

Model:	UA-135H Air Purifying Dehumidifier
Electrical:	110-120 VAC, 12 Amps, 60 Hz, grounded
Capacity:	135 pints/day @ 80°F, 60% RH
Operating Temp.:	56°F min., 100°F max.
Air Flow:	355 CFM without external ducting 335 CFM @ .20 IWG external static 315 CFM @ .40 IWG external static
Refrigerant Charge:	1 lb., 12 oz. R22
Duct Connections:	Round 10" inlet, 10" outlet
Filter Size:	Pleated cloth: 2" x 20" x 24" High Efficiency: 4" x 20" x 24" (optional)
Unit Size (w/o duct collars):	31"L x 21"W x 18 3/4"H
Shipping Size:	37"L x 25"W x 28 1/2"H
Unit Weight:	99.3 lbs.
Shipping Weight:	138 lbs.

## 4. Installation

### 4.1 Installation Checklist

**IMPORTANT:** Prior to installation of the UA-135H, the following checklist should be reviewed. The UA-135H can be installed in a variety of locations to meet the owner's needs and integrate with existing forced air systems or existing ductwork if desired. The location choice is contingent on a variety of requirements not limited to: ease of service, controls access, drainage, filtration, power, fresh-air ventilation, water damage prevention, and current regulatory codes (ASHRAE, fire, etc). Please address all of these issues before you select the devices location.

#### 4.1A Drainage and Trap

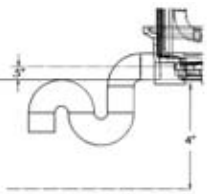

Figure 1: Trap Diagram

Unit should be located in an area where the UA-135H's condensate (water) may be easily routed to a suitable drain. Space and location requirements should take into account the incorporation of a trap for the assembly as shown in section 4.4.

#### 4.1B Filter Box & Fresh Air Ventilation

Unit location should be in an area where the unit's return (intake) side will be easily accessible for ducting. Ducting the

optional fresh air ventilation to the filter box should be easily accomplished by the unit's location.

#### 4.1C Power Accessibility

Unit should be located in an area where the cord's length (6') should easily reach a 115 VAC electrical outlet with a minimum of a 15 A circuit capacity.

#### 4.1D Space

Location should have enough clearance to handle the unit's overall dimensions as well as the necessary return/supply ductwork to the unit and the additional 4" in height for the unit to drain properly. The filter box should be accorded enough space to allow for the opening of the filter access panel and for the replacement of the filter elements.

#### 4.1E Low Voltage Wiring

Unit Location should be in an area where field wiring the remote controls (low voltage) to the unit will be possible.

#### 4.1F Sound

The UA-135H produces sound levels from 50 to 60 dB. If necessary, do not locate unit in or adjacent to areas which the unit's sound might be aggravating to the end user. For additional noise control, attach 3/4" plywood surround.

#### 4.1G Back-Draft Damper

It is recommended that a back draft damper be utilized on the supply ducts for the UA-135H. The unit location should be able to permit this accessory to be installed if requested by the end user. For more information please call customer service at (800) 533-7533.

#### 4.1H Support Structure and Suspension

Place the UA-135H on supports to raise the base of the unit approximately 4" above the horizontal floor below it. Raising the UA-135H will help the unit drain with gravity flow. Do not place the UA-135H directly on structural building members without vibration absorbers or unwanted noise may result.

The UA-135H may be suspended with steel hanger straps (plumbers tape) or a suitable alternative from structural members, as long as the suspending assembly supports the 5 individual feet of the UA-135H's base in its entirety. Remember to place a drain pan under the unit if it is suspended above a finished area or above an area where water leakage could cause damage.

#### 4.2 External Insulation Kit

An external insulation kit is available for the UA-135H. This will help prevent the cabinet from sweating if the unit is installed in an unconditioned space. This kit will increase the efficiency of the unit by eliminating unwanted heat transfer between the unit and the space. See the optional accessories list for information on the kit.

# FOR HVAC INSTALLER ONLY

## 4.3 Electrical Requirements

**WARNING: Do not allow the yellow lead from the Ultra-Aire to contact the red lead or orange lead from the Ultra-Aire or damage to the transformer will result.**

The UA-135H plugs into a common grounded 115VAC outlet. The device draws around 11.4 Amps under normal operating conditions. Note, the unit may trip the current of a 15A circuit, if the circuit contains other heavy electrical loads. If used in an area which may become wet, a ground fault interrupter (GFI) protected circuit is recommended. Please, consult local electrical codes for any further information.

Therma-Stor LLC offers a family of control devices for use with the UA-135H. The controls are to be located remotely from the unit and located in the space to be conditioned. The controls are low voltage (24 volt) and should be connected to the UA-135H with low voltage wire (thermostat or other appropriate).

Do not install the control panel where it may not accurately sense the relative humidity such as near HVAC supply registers, near exterior doors, on an outside wall, near a window, or near a water source.

The installer must supply the wiring between the UA-135H and the control panel. Be sure to safely route the control wiring to prevent damage during installation.

Do not cross wires when connecting the UA-135H and the remote control panel or damage to the transformer may result. The remote controls of the UA-135H are powered by a low voltage circuit (24VAC) and must NEVER contact or be connected to a high voltage circuit.

The control wires leaving the UA-135H and the remote control panels are numbered and color-coded to prevent confusion. Some of the control wires leaving the UA-135H may not be used with certain control panels and should be left safely disconnected with wire nuts taped onto the stripped ends. Be sure to consult the electrical schematic in this manual or inside the access panel of the UA-135H before making control connections.

## 4.4 Condensate (Water) Removal

**IMPORTANT: Incorporate a trap for the assembly as shown in Figure 2. Use care to keep the pipe assembly as flat to the floor as possible, kinks and/or humps will prevent proper drainage.**

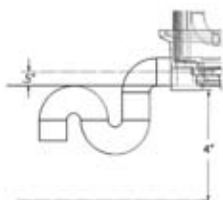

Figure 2: Trap Diagram

The Ultra-Aire APD generates condensate. Condensate drains by gravity via the 1" x 3/4" bushing extending from the unit. It is necessary to assemble your own drain pipe assembly utilizing 3/4" PVC pipe to get the condensate to a floor or other drain. Pipe is commonly available in 10'

lengths from building supply, plumbing or hardware stores. Grade of pitch should be 1" per 10'.

## 4.4A Lifting Condensate

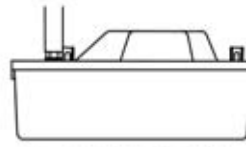

Figure 3: Condensate pump.

An optional condensate pump kit may be installed if a lift is required to dispose of the condensate. The condensate pump can be ordered direct from the factory. See the optional parts list in Section 7 for information on the kit.

## 4.5 Ducting

### 4.5A Installing Duct Collars

The UA-135H is equipped with 10" diameter round inlet and exhaust collars. The inlet collar is factory installed. The inlet collar is designed with tabs that fold inside the 10" hole located on the return panel of the UA-135H.



Figure 4: Installing exhaust collar.

To install the exhaust collar, bend all four tabs out and away from the center of the collar. The exhaust collar is attached to the UA-135H by fastening the four tabs on the outside of the supply panel to the UA-135H. Fasten the collar to the supply panel of the UA-135H by removing one fan screw, placing the collar over the four holes, then screwing the fan screw and three additional #10-24 thread cutting screws into the four holes near the 8" diameter outlet hole.

### 4.5B Ducting for Dehumidification

For the ideal installation, draw air from the central part of the home and return it to the isolated areas of the home like the bedrooms, den, utility room, or family room. The ductwork of the existing heating system can be used to supply air to the home. If the existing supply goes to isolated areas of the home, discharge the supply of the UA-135H into the supply of the existing heating system. If the existing heating system incorporates a central supply, installation of a separate supply duct from the UA-135H to each isolated area is recommended.

### 4.5C Fresh Air / Supply Air

**IMPORTANT: DO NOT draw air directly from the kitchen, laundry, or isolated basement.**

You may draw air from a basement that is open to the home. All flexible ducting connected to the UA-135H should be UL listed.

A length of 6 feet or more of flex ducting on the outlet of the UA-135H will reduce air noise from the impeller fan. A length of flexible ducting on all UA-135H duct connections is recommended to reduce noise and vibration transmitted to rigid ductwork in the structure. Ducting the UA-135H as mentioned requires consideration of the following points:

## FOR HVAC INSTALLER ONLY

**Duct Sizing:** For total duct lengths up to 25', use a minimum 10" diameter round or equivalent rectangular. For longer lengths, use a minimum 12" diameter or equivalent. Grills or diffusers on the duct ends must not excessively restrict airflow.

**Isolated Areas:** Effective dehumidification may require that ducting be branched to isolated, stagnant air flow areas. Use 8" or larger diameter branch ducting to each of two or three areas, use 6" or larger to each of four or more areas. Provisions must be made to provide airflow from supply locations to central return location. Proper air distribution is important to ensure even humidity control and heat distribution throughout the structure.

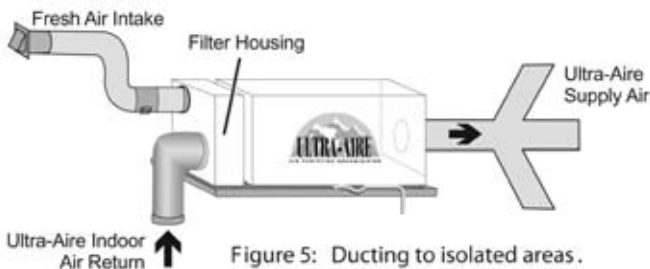

Connecting to existing HVAC systems: An optional 10" check damper is available from the factory to prevent reverse flow through the UA-135H. If the UA-135H is ducted to the supply of a high static air handler the check damper may be placed in the UA-135H supply duct.

Contact the factory when connecting to a static pressure of greater than or equal to +.5" WG.

### 4.5D Ducting for Fresh Air — Option

Fresh air can be brought into the structure by connecting an insulated duct from outside the structure to the 6" inlet of the optional filter box and by turning on the fan switch or activating the humidity control (on units with the humidity control panel). Activate the ventilation timer on units with the ventilating & humidity control panel to bring in fresh air. Refer to section "Programming Instructions" for the ventilation timer. Advantages of this form of ventilation include:

1. Outside air is filtered before entering the building.
2. Outside air will be dehumidified before entering if the UA-135H is running in dehumidification mode.
3. Drawing air from outside and blowing inside aids in slightly pressurizing the structure. This helps prevent dirty and humid air from entering elsewhere. It also reduces the potential for carcinogenic radon gas to enter and provides make-up air for open combustion and exhaust devices like the clothes drier, fireplace, and water heater.
4. Exhaust fans are recommended in the bath rooms and kitchen.

In cold climates or areas where the outdoor dew point is low at times, ventilation can be used to dehumidify the structure. This is accomplished by bringing the dry, low dew point air into

the structure during these times. This approach is often more economical than running the dehumidifier to remove excess moisture from the structure. In cold climates, it is critical to adequately ventilate to reduce the inside moisture content to avoid moisture accumulating in the wall cavities. For example; in a house that experiences condensation on the interior surface of the windows during the winter, increasing the amount of ventilation will often cure the problem.

An insulated 6" diameter duct is generally sufficient to provide up to 125 CFM of outside air. Large quantities of outside air will impact UA-135H performance positively or negatively, depending upon the inside and outside air conditions.

The outside air duct should be connected to the 6" round collar on the filter enclosure of the unit. The amount of fresh air should be based on the size and occupancy of the residence. If you are unsure of your ventilation air requirements or have need for higher air flows, consult the factory by calling 1-800-533-7533 for assistance.

### 4.5E Installation in a Basement or Crawspace with an Existing Forced Air HVAC System.

**Basement Installation:** Install a separate 10" return for the UA-135H in a central area of the structure. Duct the supply of the Ultra-Aire to a 10" x 10" x 10" tee/damper, adjusted to 20% open to the basement. Duct the other side of the tee to the air supply of the existing HVAC system. Connect a duct from outside to the 6" collar of the Ultra-Aire if you wish to provide fresh make-up air. See Figure 6.

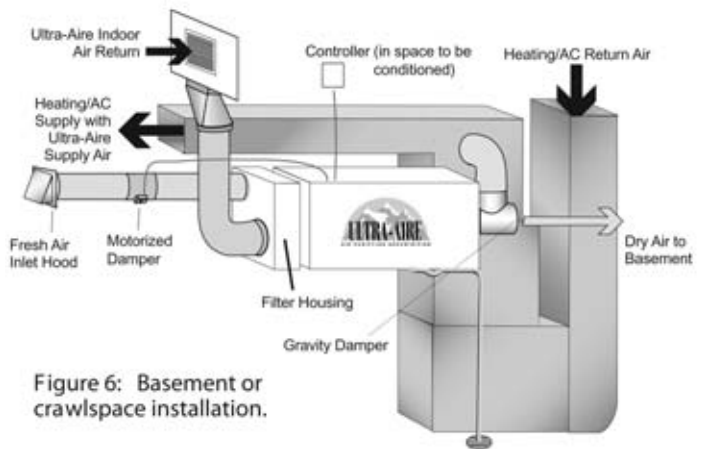

**Crawspace Installation:** Install a separate return for the UA-135H in a central area of the structure. Duct the supply of the UA-135H to a 10" x 10" x 10" tee/damper that is 20% open to the crawspace if desired. Duct the other side of the tee to the air supply of the existing HVAC system. Connect an insulated duct from outside to the 6" collar of the UA-135H if you wish to provide optional fresh make-up air.

If the existing system has multiple returns, select one to disconnect from the existing forced air system and use it for the dedicated

# FOR HVAC INSTALLER ONLY

Ultra-Aire return. Always select a return from a central location in the structure in an area that is always open to the rest of the structure. Do not use a return from a room that may have its door closed much of the time or, alternatively, install a separate return from the open part of the house.

## 4.5F Installation in an Attic with an Existing Forced Air HVAC System

ALWAYS install a catch pan with a drain or float interrupt for condensate under the UA-135H in an attic or condensate may damage the living space below.

The preferred method of installation is to create a separate return for the UA-135H in a central area of the structure. Duct the supply of the UA-135H to the air supply of the existing HVAC system. Connect an insulated duct from outside to the 6" collar of the UA-135H if you wish to provide fresh make-up air. Adjust a damper in the duct to provide the desired amount of fresh air. See Figure 7.

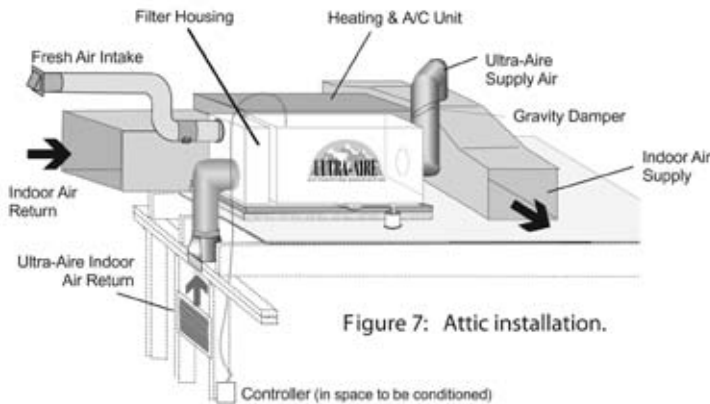

## 4.5G Installation in a Structure with Two Forced Air HVAC Systems

When installing the UA-135H in a space with two HVAC systems, the outlet air of the UA-135H may be ducted into the supply ducting of each system. The 10" outlet of the UA-135H may be split into two separate ducts by using a "T" or "Y" adapter. It is recommended to install a manual damper (balancing damper) and a backdraft damper in each duct, then connect to the supply ducting of each HVAC system. The balancing dampers provide the ability to control airflow into each system. The backdraft dampers prevent cross flow of air from one system to the other when only one system is active. See Figure 8.

## 4.5H Installation in a Structure with No Existing Forced Air HVAC System

When installing the UA-135H in a structure that does not have a forced air HVAC system, a single return for the UA-135H should be installed in central open area of the structure. DO NOT locate the return in a bathroom or a kitchen. The supplies of the UA-135H should be located in the remote areas of the structure (such as bedrooms, den, etc.). By ducting this way, the air inside the structure

will circulate through the UA-135H to be filtered and dehumidified. 4" diameter duct is recommended for branches to the bedrooms, 6" diameter duct is recommended for branches to larger areas. Connect an insulated duct from outside to the 6" collar of the UA-135H if you wish to provide fresh make-up air.

## 4.6 Compressor Release & Noise Abatement

The compressor is attached to the partition with one cable tie and a 1.5" x 1.5" x 4.5" foam pad to secure it during shipment. This rigid attachment must be removed once the unit is installed and may cause noise from compressor vibration. After installation, remove the service panel, cut and remove the cable tie and foam pad securing the compressor's accumulator to the partition. This will prevent the compressor from transmitting vibration to the cabinet.

For further noise abatement, make sure none of the refrigeration tubes are pressed against the cabinet or access panel. Check that the refrigeration tubes are centered in the holes where they pass through the partition. For additional noise control, attach 3/4" plywood surround.

A length of 10 feet or more of acoustical flex ducting on the outlet of the UA-135H will reduce air noise from the impeller fan. A length of flexible ducting on all UA-135H duct connections is recommended to reduce noise and vibration transmitted to rigid ductwork in the structure.

## 4.7 Controls

All control panels should be mounted in a central area of the structure where it can accurately sense the humidity of the air in the living space and be accessed. All controls require field wiring from the unit location to the panel mount location.

To determine how each control operates the UA-135H it must first be determined which control is being used and whether or not the 135H is ducted for fresh air ventilation.

### Humidity/Fan Control Panel (P/N 4024155)

- 4.7A Humidity/Fan Control Panel WITHOUT Fresh Air Ventilation or Damper
- 4.7B Humidity/Fan Control Panel WITH Fresh Air Ventilation and WITHOUT Damper
- 4.7C Humidity/Fan Control Panel WITH Fresh Air Ventilation AND Damper

### Ventilation Timer/Humidity Control Panel (P/N 4024125)

- 4.7D Ventilation Timer and Humidity Control WITH Fresh Air AND Motorized Damper

### DEH 2000 Digital Control (P/N 4024539)

- 4.7E Digital Controller WITH Fresh Air AND Damper
- 4.7F Digital Controller WITHOUT Fresh Air

## 4.7A Humidity/Fan Control Panel WITHOUT Fresh Air Ventilation or Damper

The humidity/fan control panel automatically controls the humidity of the living space. The humidity/fan control panel contains an adjustable humidity control and a fan switch. The panel has a cover that must remain open to the air within the living space for accurate

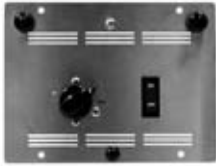

Figure 10: Humidity/Fan Control Panel



Figure 11: Ventilation Timer and Humidity Control Panel

humidity sensing. Position the fan switch ON when the home is occupied. This filters and circulates air throughout the home. For humidity control operation refer to section 4.8.

## 4.7B Humidity/Fan Control Panel WITH Fresh Air Ventilation and WITHOUT Damper

The humidity/fan control panel automatically controls the humidity of the living space. The humidity/fan control panel contains an adjustable humidity control and a fan switch. The panel has a cover that must remain open to the air within the living space for accurate humidity sensing. Position the fan switch "ON" when the home is occupied. This filters and circulates air throughout the home. Outside air is introduced whenever fan is "ON." Manual operation of fan filter switch controls outside air and ventilation. Since the fan operates whenever the UA-135H is dehumidifying outside air will be introduced. For humidity control operation refer to section 4.8.

## 4.7C Humidity/Fan Control Panel WITH Fresh Air Ventilation AND Damper

In this configuration, a motorized damper has been installed in the fresh air duct. When the fan/filter switch is in the "OFF" position, the damper is closed. The UA-135H will then circulate and dehumidify air to provide humidity control. When the fan/filter switch is in the "ON" position, the motorized damper will open and the fan will run, introducing outside air. The unit may or may not be dehumidifying in the ventilation mode, depending on the humidity control setting. See Section

## 4.7D Ventilation Timer and Humidity Control WITH Fresh Air AND Motorized Damper

Refer to sections 4.8 through 4.13.

## 4.7E DEH 2000 Digital Controller WITH Fresh Air AND Damper

Refer to Section 5.

## 4.7F DEH 2000 Digital Controller WITHOUT Fresh Air

Refer to Sections 5 through Section 5.2G only.

## 4.8 Humidity Control Adjustment



Figure 12  
Humidity Control Adjustment Knob

Set the humidity control to the desired humidity level for the home. Turning the knob clockwise results in a drier setting. See the back of the control panel cover for set points. The dehumidifier will run continuously until the relative humidity (RH) is reduced to the humidity control dial setting. Setting the humidity control to lower RH levels will NOT increase the unit's dehumidification rate; the unit will simply run longer to reduce the area's RH to the setting. The UA-135H unit (and refrigerant-based dehumidifiers in general) will reduce a warm space's RH to a lower level than that of a cool space. Therefore there is no benefit to set the humidity control to excessively low levels in cool rooms; doing so will result in long periods of ineffective dehumidifier run time. Settings below 45% are not recommended.

## 4.9 Fan/Filter Switch



Figure 13  
Fan/Filter Switch

Turning ON the fan/filter switch to "FAN ON" position will cause the UA-135H impeller fan to run continuously, whether the UA-135H is dehumidifying or not. This function is desirable if the unit is used for air circulation and filtration to achieve maximum indoor air quality. When the switch is "FAN ON" position, air will be constantly filtered through the UA-135H and circulated throughout the house. When the switch is "FAN AUTO" position the impeller fan will operate only when the humidity control calls for dehumidification or when the ventilation timer calls for ventilation.

## 4.10 Ventilation Timer

The ventilation timer controls the impeller fan and the motorized fresh air damper. When the ventilation timer is activated, the UA-135H will circulate the indoor air, and bring in fresh air from outside. The ventilation timer should be set for the required ventilation of the residence. The home should be ventilated with fresh air as suggested by applicable codes and standards. The ventilation timer is an electronic timer that displays the current time. This timer has battery backup, so it will not require resetting after a power outage. Following a prolonged power outage the display of the timer will flash on and off indicating a power outage has occurred. The one-minute time increments of the ventilation timer allow you to program the ventilation of your home to fit your schedule.

The ventilation timer allows six programs with each program having one "on" and one "off" event. A program allows the user to turn the ventilation on at a certain day and time, then it allows them to turn the ventilation off at a certain day and time. Each of these programs can be repeated daily or weekly or during a specified block of days. All six of the programs operate independently of each other. If the timer fails to operate or operates erratically, check that the control



## FOR HVAC INSTALLER ONLY

panel receives 24Vac from the UA-135H. If 24Vac is present at the control panel, reset the timer by pressing the reset button at the bottom center of the timer face. The reset button is the small recessed button with an R beneath it located below the 1...7 and h buttons. Depress the reset button until the display clears. Release the reset button. The display will reappear as 00:00. Resetting the timer will clear the time and all program settings. After resetting the timer follow the instructions below to set the correct time and ventilation programs.

### 4.11 Setting the Time

First, set the correct time on the timer by sliding the switch in the upper right hand corner of the timer to the clock symbol. and pressing the 1...7 (DAY), h (HOUR), and m (MINUTE) buttons. Remember this timer operates on a 24-hour (military time) clock.

### 4.12 Ventilation Schedule

Slide the switch in the upper right hand corner to the program symbol P. "ON" will appear to the right of the time and the number "1" will appear in the lower right hand corner of the display. The "1" and "ON" signify the turn on time for the first program. Press the 1...7, h and m button to choose the days of the week for this program. You can choose Mon.-Sun, Mon.-Fri., Sat-Sun, or any single day of the week. The days chosen are shown along the top of the display on the ventilation timer. Next press the h button to set the hour for the start of the ventilation period. Remember this timer operates on a 24-hour clock (military time). Then press the m button to set the minutes past the hour to start the ventilation. Now, with the ventilation start time set; press the I/O button. The word "OFF" should appear to the right of the time and the number "1" should remain in the lower right hand corner of the display. The "1" and "OFF" signify the turn off time for the first program. Set the turn off time using the 1...7, h and m buttons in the same way as described above and continue on to the second through sixth programs. When setting the ventilation programs, you can return to the current time display by sliding the switch in the upper right corner of the timer to RUN. The slide switch must be set to RUN for the timer to operate its scheduled programs.

### 4.13 Automatic or Manual Mode

The slide switch in the upper left of the timer is used to choose between automatic and manual operation. When the slide switch is set to AUTO mode, the UA-135H will ventilate when the scheduled programs call for ventilation. When the slide switch is set to manual (set to hand symbol on the right), the operation of the timer is controlled by the I/O button only. Pressing the I/O button will switch the ventilation timer between ON (detent) and OFF (detent). As you press the I/O button, "ON" or "OFF" will be displayed to the right of the time. The "ON" or "OFF" indicates if the ventilation timer is on or off. The I/O button will manually override scheduled programs if the timer is in AUTO mode.

# ATTENTION INSTALLER

## WIRE THE UNIT AND CONTROL PACKAGE AS SHOWN IN THE DIAGRAM BELOW

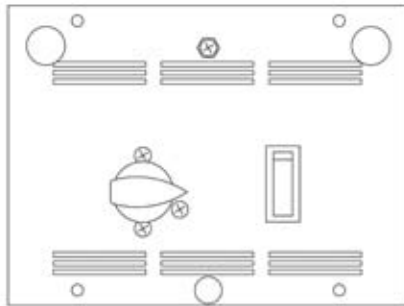

CONTROL PART No. 4024155

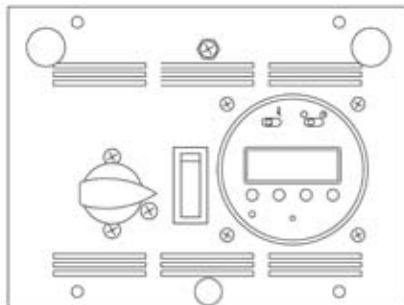
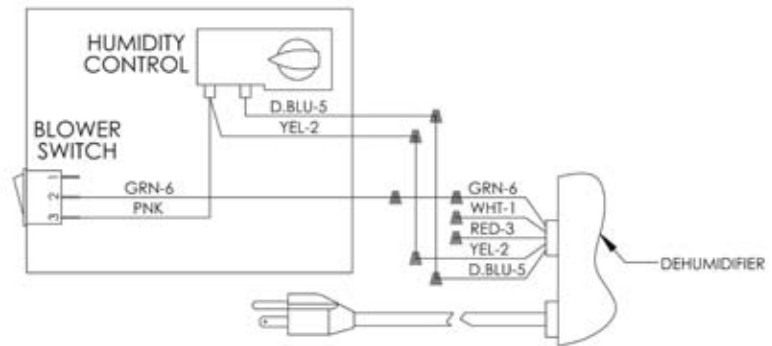

CONTROL PART No. 4024125

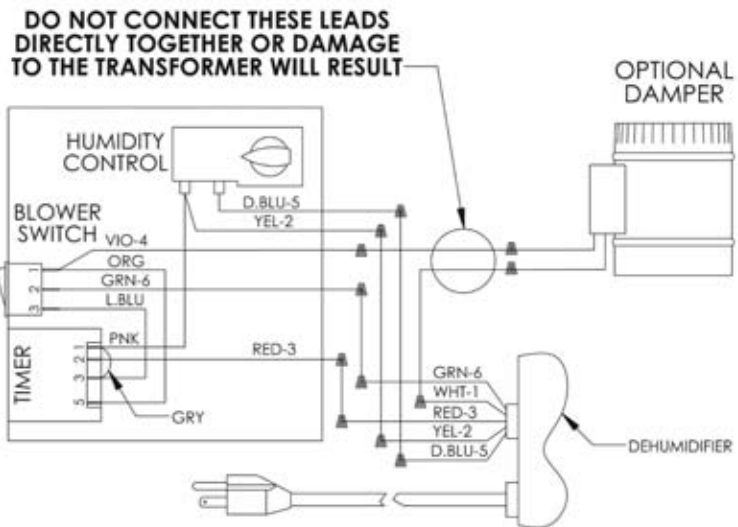

CONTROL PART No. 4024539

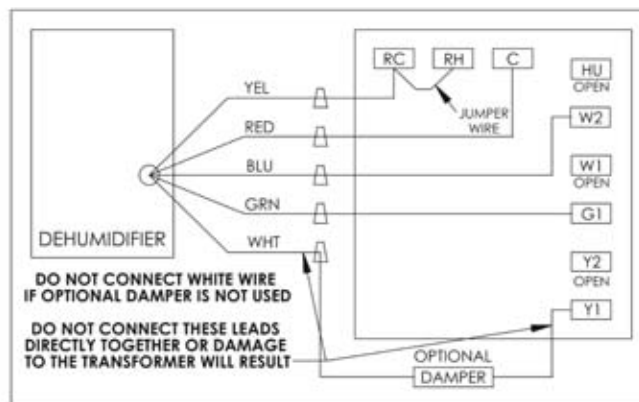

**WARNING: DO NOT** allow the yellow lead from the unit to contact the red lead or the white lead from the unit or damage to the transformers will result. Do not direct connect the white lead on the unit to the violet lead on the ventilation control or damage to the transformer will result.

## 5. (DEH 2000) DIGITAL CONTROL Installation Instructions

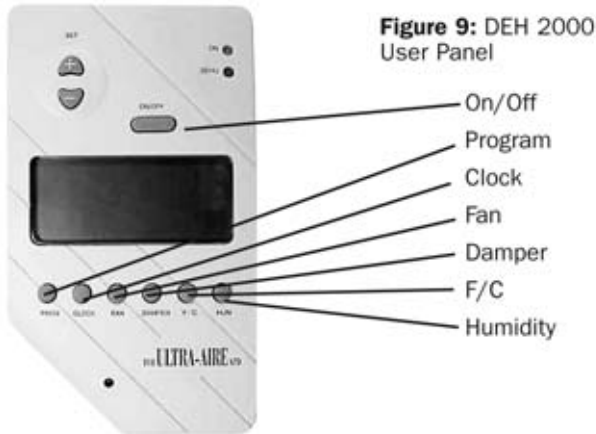

### 5.1 Specifications

Model: 4024539  
 Electrical: 24 VAC  
 Humidity Range: 20 – 90%  
 RH Humidity Accuracy: +/- 4%  
 Output: 3 Amps 24 VAC

### 5.2 Installation

This control panel must be installed in the conditioned space and in accordance with all applicable codes and standards. Follow the instructions below when installing and setting this control.

#### 5.2A Install Instructions

1. Separate the front panel from the back panel by depressing the tongue located in the bottom of the control.



2. Gently disconnect the quick connector on the back panel
3. Remove the battery from the back panel by sliding it to the left and out from its retaining clip. To mount in the black battery holder on the front panel, insert it from the top, gently pressing downward until it snaps into place and is held under the top clip of the holder. The + engraved on the battery should be visible.
4. Line the back panel up against the wall or flat surface onto which it is to be mounted and drill in the appropriate mounting holes
5. Insert the screws so they extend approximately 1/8" from the wall or flat surface.
6. Align the back panel against these screws, pushing it forward,

- allowing it to slide downward to lock into position.
7. Make the electrical connections to the terminals on the back panel as shown in the wiring diagram.
8. Seal the hole around the wires to prevent air movement.
9. Reconnect the quick connector onto the back panel.
10. Reassemble the front to the back panel. Connect at the top first, then at the bottom.

### 5.2B Wiring

## ! WARNING

**Warning:** Do not allow the yellow lead from the Ultra-Aire to contact the red lead or orange lead from the Ultra-Aire or damage to the transformer will result.

The installer must supply the wiring between the Ultra-Aire and the control panel. Be sure to safely route the control wires to prevent damage during installation. Be careful not to cross wires when connecting the Ultra-Aire and the remote control panel or damage to the transformer may result.

## ! IMPORTANT

The remote controls of the Ultra-Aire are powered by a low voltage circuit (24 VAC) and must NEVER contact or be connected to a high voltage circuit.

Some of the control wires may not be used with certain control panels and should be left safely disconnected with wire nuts taped onto the stripped ends. Be sure to consult the electrical schematic in this manual before making the control connections.

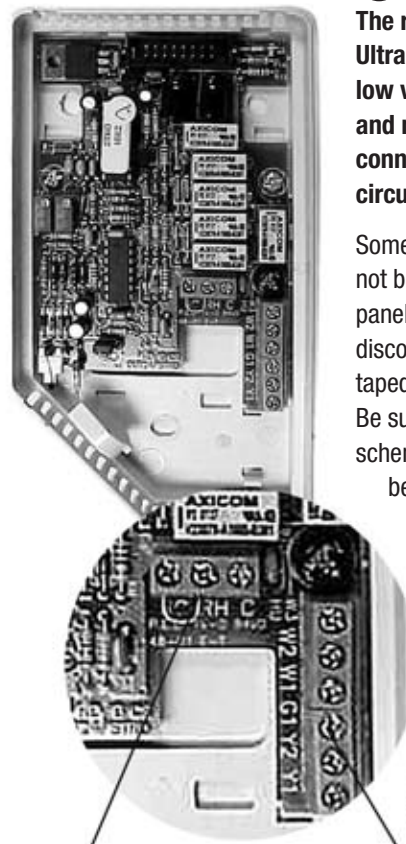

<b>RC</b> - 24 VAC Yellow Wire	<b>RC</b> - 24 VAC Yellow Wire	<b>HU</b> - Not Used	<b>G1</b> - Fan Green Wire
<b>RH</b> - Not Used	<b>RH</b> - Not Used	<b>W2</b> - Dehumidistat	<b>Y2</b> - Not Used
<b>C</b> - 24 VAC Red Wire	<b>C</b> - 24 VAC Red Wire	Dark Blue Wire	<b>Y1</b> - Damper (See Warning Next Page)
		<b>W1</b> - Not Used	White Wire

**! IMPORTANT** Leave Jumper Wire RC and RH in place.

# FOR HVAC INSTALLER AND HOMEOWNER

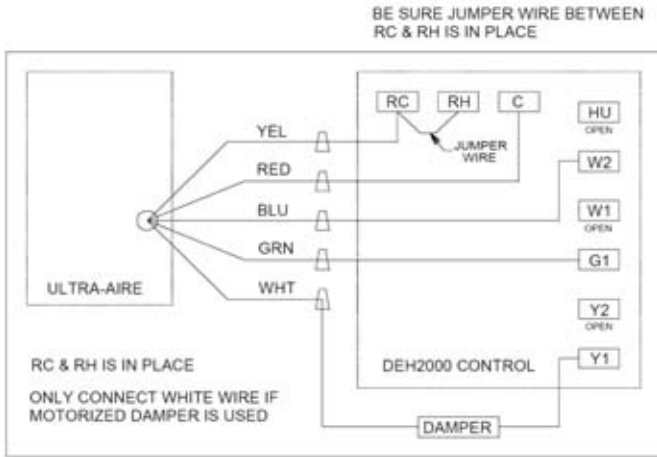

Figure 12: DEH 2000 Wiring Diagram

## ! WARNING

**Warning: Connecting the white wire to the control terminal without use of a motorized damper could create a short resulting in damage to the transformer.**

The white wire controls the motorized damper that can be installed into a fresh air duct. This provides the ability to control when fresh air is introduced into the building by using the ventilation timer function labeled “damper” on the control. If the motorized damper is not used, **DO NOT CONNECT THE WHITE WIRE TO THE CONTROL OR DAMAGE TO THE TRANSFORMER MAY RESULT.** Simply leave the white wire terminal (Y1) unused if the damper is not used.

### 5.2C Location

Install the remote control panel in a central area of the structure where it will sense the relative humidity of the structure accurately. Do not install the control panel where it may not accurately sense the relative humidity such as near HVAC supply registers, near exterior doors and windows, or near a pool or spa.

## 5.3 Operation

### 5.3A Display

When there is power to the control, the control display sequence will alternately show the clock, humidity, temperature, fan status, and fresh air damper status. The display sequence repeats continually, and is referred to as “home state”.

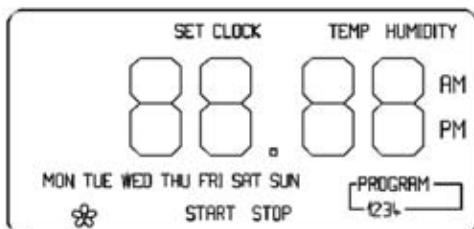

Figure 13: DEH 2000 digital display.

- The word “CLOCK” appears at the top of the display during the clock display, along with the day and time.
- The word “HUMIDITY” appears during the humidity display, with the current Set point on the left, and the ambient RH on the right.
- The word “TEMP” appears as the unit displays the current temperature.
- The fan status display is indicated by a capitol “F”. “OF” indicates fan off status, “on” indicates fan on status.
- The damper display is indicated by a “d” with the same on/off status indicators as the temperature.
- The ventilation program is displayed along the bottom of the display during the clock, humidity, and temperature displays only when the damper operation is set to the programmed setting “Pr”.

### 5.3B Setting

During the set-up process, if you make a mistake, you can always go back to adjust the settings. If you leave the control alone and don’t touch any buttons for 10 seconds, the control will remember any changes made and return to “home state.”

### 5.3C On/Off Setting

Press the “ON/OFF” button to turn the system on or off. When the system is on, the green indicator will be lit. In the off mode, the controller continues the regular display sequence and indicates current time, temperature, and relative humidity. It also displays the status of the fan and damper as if the control were on, but the fan and damper will not operate unless the control is on and the green indicator is lit. Setup can be done with the control either on or off.

### 5.3D Setting Clock Time

1. Push “CLOCK” button. The hour display will flash, use the “SET” + or – button to adjust hour. Notice the a.m./p.m. display.
2. Push “CLOCK” button again. The minute display will flash. Use the “+,-” buttons to adjust to the proper time.
3. Push “CLOCK” button again. The day display will flash. Use the “+,-” buttons to select the proper day.
4. Push “CLOCK” button again. The AM/PM display will flash. Verify AM/PM setting is correct.
5. Push “CLOCK” button again, or wait a few seconds for the display to stop flashing. The time is now set.



Figure 14: Setting clock time.

## 5.3E Setting Relative Humidity Set point

The relative humidity Set point operates the dehumidifier function of the Ultra-Aire. It has no effect on any other function of the unit. The control senses the ambient relative humidity of the space in which it is located. The ambient condition is displayed on the right in the relative humidity display sequence, under the word "HUMIDITY". The current Set point is displayed on the left, under the word "SET".



Figure 15: Setting relative humidity Set point.

If the Set point is equal to or greater than the current ambient condition, the space does not need to be dried, so the dehumidifier function will be off. Example: Set point: 50%RH Current condition 45% RH = Dehumidifier off, red "DEHU" indicator not lit.

If the Set point is less than the ambient condition, the dehumidifier will be on, and the red "DEHU" indicator will be lit. The space is more humid than the Set point, so the controller operates the dehumidifier to dry the space. Example: Set point: 50% RH Current condition: 55% RH = Dehumidifier on, red "DEHU" indicator lit.

To set the relative humidity Set point, press the "HUM" button. The display will show the "HUMIDITY" display, and the word "SET" will flash. Use the "SET" + or – buttons to adjust the relative humidity Set point as desired. Therma-Stor recommends relative humidity levels of 45% in the summer, and lower levels in the winter. It is not recommended the humidity Set point be set below 35%. In order to dry the home in the winter in a cold climate, use the ventilation function of the system rather than the dehumidifier function.

## 5.3F Fan Setting and Operation

Use the "FAN" button to adjust the fan operation. There are 3 choices for fan operation: "on", "off" (denoted by "OF"), or program (denoted by "Pr"). To set operation,

1. Press the "FAN" button. The display will indicate the current fan setting.
2. Use the "SET" + or – buttons to adjust fan operation ("on", "OF" or "Pr"). Press the "FAN" button again or leave the unit alone for 10 seconds to return to home state.



Figure 16: Programming the fan.

## 5.3G Fan On Fan Off Fan Program

The fan display reading in the normal display sequence does not indicate the current fan setting, it indicates the current fan status, and will always read either on or off. With the fan in the

"on" mode, the fan will run continuously. This does not effect the dehumidification functions of the system. The system may or may not be ventilating or dehumidifying while the fan is running. Common reasons for operating the fan continuously are continuous filtration and air recirculation. With the fan in the "off" or "program" mode, the fan will operate only when needed by other functions of the system. The fan will remain off unless the system is dehumidifying and/or ventilating. The fan always runs during dehumidification, it also always runs during ventilation. To completely turn the system off, use the "ON/OFF" button as described earlier.

## 5.3H Damper Operation and Setting (Ventilation)

The damper setting controls the ventilation function of the system. It has no control over the dehumidification function. In order to provide ventilation, the damper must be open ("on") and the fan must be running. The controller takes care of these two functions automatically, so whenever the damper is open ("on"), the fan is running.

This is true even if the fan has been set to the "off" mode. The ventilation indicator will be lit whenever the unit is ventilating.

There are three damper operation modes, "on", "off" (denoted by "OF"), and program (denoted by "Pr"). With the damper in the "on" mode, the damper will be open and the fan of the system will be operating in order to introduce fresh air into the space. Use this mode for continuous fresh air ventilation. The fan is always on when the damper is open. When in "off" mode, the damper will not open and the system will not ventilate.

When in the "program" mode, the control will operate the damper and fan (ventilate) according to the programmed ventilation schedule (see the section referring to programming the ventilation schedule).

### To select damper operation:

1. Press the "DAMPER" button. The letter "d" will appear on the display, along with the current mode setting.
2. Use the "SET" + or – buttons to adjust the fan setting to the desired mode ("on", "OF", or "Pr").
3. Press the "DAMPER" button again or leave the control alone for 10 seconds to select the indicated damper mode and return to the home state.



Figure 17: Damper operation and setting.

## 5.3I Intermittent or Programmed Ventilation

With the damper in program mode (denoted by “Pr” when setting the damper operation) the system will operate the ventilation function according to the current ventilation program.

There are 4 programs available for ventilation Monday through Friday. There are also 4 programs for Saturday and 4 programs for Sunday. No other choice of days is available. Each program to be used has an “on event” called “START” which brings the ventilation function on, and an “off event” called “STOP” which turns the function off. Each START and STOP must be entered in to the controller.



Figure 18: Programmed ventilation.

To set or adjust the ventilation program:

1. Press the “PROG” button two times. The display will indicate “Program 1/start” at the bottom, and the hour display will flash.
2. Use the “SET” + or – button to adjust the hour for the Program 1 start time. Be sure to pay attention to the am/pm setting.
3. Press the “PROG” button again. The display will indicate “Program 1/start” at the bottom, and now the minute display will flash.
4. Use the “SET” + or – buttons to adjust to the desired minute setting.
5. Press the “PROG” button again to move on to the “Program 1/stop” event. The display will indicate “Program 1/stop” at the bottom, and the hour display will flash.
6. Use the “SET” + or – button to adjust the hour for the Program 1 stop time. Be sure to pay attention to the am/pm setting.
7. Press the “PROG” button again. The display will indicate “Program 1/stop” at the bottom, and now the minute display will flash.
8. Use the “SET” + or – buttons to adjust to the desired minute setting.

9. Pressing the “PROG” button again to move onto “program 2/stop” and begin the process again if setting the other programs. Follow the same procedure for each program.

10. To end the program process simply leave the control alone (don’t push any buttons) for about 10 seconds. The unit will remember any changes and return to “home state”.

## 5.3J Programming Notes

To run the ventilation program, the damper mode must be in the “program” mode (“Pr”).

The timer can be operated manually without changing the program by adjusting the damper mode from “program” to either “on” or “off”.

To delete a program after it has been entered, adjust the program so the “START” and “STOP” times are identical.

Occupants should determine ventilation times and rates. Therma-Stor makes no firm recommendations concerning when to ventilate. Common ventilation schedules include constant ventilation, ventilation based on occupancy times, intermittent operation, and seasonal ventilation.

Remember the control must be on for the unit to be functioning - make sure the green power indicator “ON” is lit.

## 5.3K Ventilating or Dehumidifying to Control Indoor Relative Humidity Levels

Fresh air ventilation may have a drying effect or a wetting effect on the indoor space, depending on the amount of moisture present in the outdoor air. Relative humidity is not a good indicator of outside humidity levels: use dew point measurements instead. Consider outside humidity levels when using the ventilation function of the dehumidifier.

## 5.3L Stop Start

During summer in hot, humid climates operating in ventilation mode will increase the moisture load in the home.

Consider reducing the amount or frequency of fresh air ventilation if indoor humidity continues to be high.

## 5.4 Low Pressure Control

If the low side refrigerant pressure drops to 15 PSIG, the low-pressure control opens and shuts off the compressor and impeller fan. It is an automatically reset control that will close when the pressure rises to 35 PSIG. Its primary function is to prevent damage to the compressor if a leak develops in the refrigeration system. It may also open if the unit is A) installed in a cool area (below 50 F) or B) installed where it is below 40 F and then started. Under these conditions, the unit will restart within several minutes. Until the unit warms up, it may repeat the cycle several times.

## 6. Service

**CAUTION:** Servicing the UA-135H with its high pressure refrigerant system and high voltage circuitry presents a health hazard which could result in death, serious bodily injury, and/or property damage. Only qualified service people should service this unit.

### 6.1 Technical Description

The UA-135H uses a refrigeration system similar to an air conditioner's to remove heat and moisture from incoming air, and add heat to the air that is discharged. Hot, high-pressure refrigerant gas is routed from the compressor to the condenser coil (See Figure 1). The refrigerant is cooled and condensed by giving up its heat to the air that is about to be discharged from the unit. The refrigerant liquid then passes through a filter/drier and capillary tubing which causes the refrigerant pressure and temperature to drop. It next enters the evaporator coil where it absorbs heat from the incoming air and evaporates. The evaporator operates in a flooded condition, which means that all the evaporator tubes contain liquid refrigerant during normal operation. A flooded evaporator should maintain nearly constant pressure and temperature across the entire coil, from inlet to outlet.

The mixture of gas and liquid refrigerant enter the accumulator after leaving the evaporator coil. The accumulator prevents any liquid refrigerant from reaching the compressor. The compressor evacuates the cool refrigerant gas from the accumulator and compresses it to a high pressure and temperature

### 6.2 Troubleshooting

**No dehumidification, neither impeller fan nor compressor run with fan switch and ventilation timer OFF.**

1. Unit unplugged or no power to outlet.
2. Humidity control set too high or defective.
3. Loose connection in internal or control wiring.
4. Defective Compressor relay.
5. Defective control transformer.
6. Low pressure Control open.
7. Optional Condensate Pump Safety Switch open.

**No dehumidification, compressor does not run but impeller fan runs with fan switch and ventilation timer OFF and humidity control turned to ON.**

1. Defective compressor run capacitor.
2. Bad connection in compressor circuit.
3. Defective compressor overload.
4. Defective compressor.
5. Defrost thermostat open.

**Impeller fan runs with fan switch and ventilation timer OFF, but compressor cycles on & off.**

1. Low ambient temperature and/or humidity causing unit to cycle through defrost mode.

2. Defective compressor overload.
3. Defective compressor.
4. Defrost thermostat defective.
5. Dirty air filter(s) or airflow restricted.
6. Low refrigerant charge, causing defrost control to cycle.
7. Bad connection in compressor circuit. Impeller fan does not run with fan switch in either position.

**Impeller fan does not run with ventilation timer activated. Compressor runs briefly but cycles on & off with humidity control turned to ON.**

1. Loose connection in impeller fan circuit.
2. Obstruction prevents impeller fan rotation.
3. Defective impeller fan.
4. Defective impeller fan relay.
5. Defective impeller fan capacitor.

**Impeller fan runs with fan switch ON. Impeller fan does not run with ventilation timer activated.**

1. Defective ventilation timer.
2. Time not correct on ventilation timer.
3. Ventilation timer set to manual & switched OFF.
4. Defective fan switch.

**Evaporator coil frosted continuously, low dehumidifying capacity.**

1. Defrost thermostat loose or defective.
2. Low refrigerant charge
3. Dirty air filter(s) or airflow restricted.
4. Excessively restrictive ducting connected to unit.

**Unit not providing ventilation. Ventilation timer not operating correctly.**

1. If timer is not functioning correctly reset timer and reprogram.
2. Check control wire connections (check connections at fresh air damper also).
3. Defective fresh air damper.
4. Defective fan switch.

**Unit removes some water, but not as much as expected.**

1. Air temperature and/or humidity have dropped.
2. Humidity meter and or thermometer used are out of calibration.
3. Unit has entered defrost cycle.
4. Air filter dirty.
5. Defective defrost thermostat.
6. Low refrigerant charge.
7. Air leak such as loose cover or ducting leaks.
8. Defective compressor.
9. Restrictive ducting.
10. Optional Condensate Pump Safety Switch open.

**Unit Test to determine problem:**

1. Detach field control wiring connections from main unit.
2. Connect the yellow and green pigtailed from the main unit together;

only the impeller fan should run. Disconnect the wires.

3. Connect the yellow and blue pigtails from the main unit together; the compressor and impeller fan should run.
4. If these tests work, the main unit is working properly. You should check the control panel and field control wiring for problems next.
5. Remove the control panel from the mounting box and detach it from the field installed control wiring. Connect the blue, yellow, and green wires from the control panel directly to the corresponding colored pigtails on the main unit. Leave the violet, white and red wires disconnected!
6. Turn on the fan switch; the impeller fan should run. Turn off the fan switch.
7. Turn on the humidity control; the compressor and impeller fan should run.
8. If these tests work, the problem is most likely in the field control wiring.

### 6.3 Refrigerant Charging

If the refrigerant charge is lost due to service or a leak, a new charge must be accurately weighed in. If any of the old charge is left in the system, it must be recovered before weighing in the new charge. Refer to the unit nameplate for the correct charge weight and refrigerant type.

### 6.4 Impeller Fan Replacement

The motorized impeller fan is a unitary assembly consisting of the motor and impeller fan. If defective, the complete assembly must be replaced.

1. Unplug the power cord
2. Remove the cabinet access panel
3. Disconnect the impeller's blue, black, brown leads, which are attached to the capacitors as well as the green/yellow ground lead.
4. Remove the impeller access plate, which is the D-shaped plate mounted to the supply/exhaust panel of the UA-135H. The impeller should be attached to this D-shaped plate. Pull the leads through the black plastic scroll housing inside, as you remove the impeller access plate.
5. Remove the two cable clamps securing the impeller cord to the access plate.
6. Remove the defective impeller from the access plate
7. Reassemble the new impeller fan by reversing the above procedure. Note: Make sure that the new impeller cord is secured tightly to the impeller access plate utilizing the two cable clamps given with the unit. Make sure to reconnect all leads in their correct positions.

### 6.5 Compressor/Capacitor Replacement

This compressor is equipped with a two terminal external overload and a run capacitor, but no start capacitor or relay.

**CAUTION-ELECTRICAL SHOCK HAZARD: Electrical power must be present to perform some tests. These tests should be performed by a qualified service person.**

### 6.6 Replacing a Compressor, Nonburn Out

Remove the refrigerant from the system. Replace the compressor and liquid line filter/drier. Charge the system to 50 PSIG and check for leaks. Remove the charge and weigh in the refrigerant quantity listed on the nameplate. Operate the system to verify performance.

### 6.7 Electric Ventilation Damper

The electric ventilation damper is controlled by the ventilation timer. The damper will open when the ventilation timer is activated to allow fresh air into the structure through the 6" diameter fresh air inlet duct. The electric ventilation damper will remain closed when the ventilation timer is not activated to prevent over-ventilating the structure when the unit is dehumidifying or recirculating the indoor air. The electric ventilation timer operates on 24 Vac from the control circuit. DO NOT connect high voltage to the damper motor or damage to the motor may result. DO NOT force the blade of the damper by hand or damage to the damper motor may result.

The damper opens in one direction only. The damper rotates very slowly, allow sufficient time for the damper to cycle. The damper will take approximately 1 minute to cycle from closed to open or from open to closed.

#### If the electric ventilation damper fails to operate:

1. Check that the wiring is correct and that voltage is present at the damper motor.
2. Check for any obstruction inside the damper. If the electric ventilation damper fails to operate after performing these checks, it must be replaced.

### 6.8 Condensate Pump Kit

An optional condensate pump kit is available from the factory for use with the UA-135H. Condensate is automatically pumped to a remote

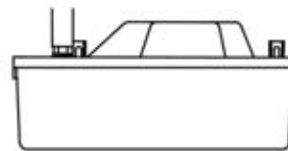
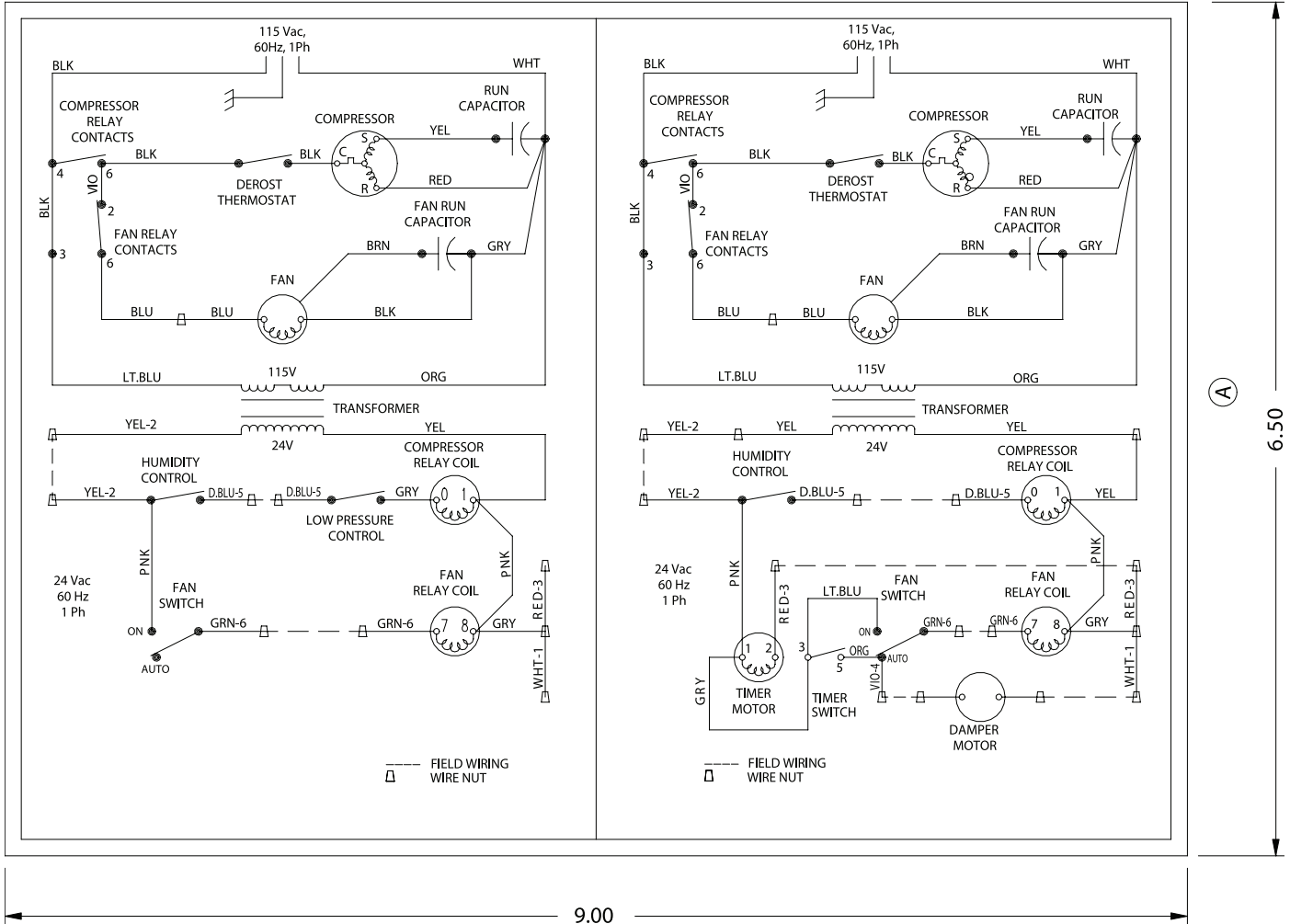

Figure 23: Condensate pump.

location when the water level in the pump's reservoir rises to close the float switch. The pump also contains a safety float switch. The white leads from this switch extend from beneath the pump cover. This switch should be installed in series with the field wire that connects the blue (#5) lead from the UA-135H to the blue (#5) lead on the control panel. If the pump fails, this switch opens the compressor control circuit and stops water production before the reservoir overflows. The UA-135H will continue to ventilate or circulate air as normal, but will not dehumidify until this switch closes.



# WIRING DIAGRAMS



**UA-135H With Humidity/Fan Control (4024155)**

**UA-135H W/Ventilation Timer/  
Humidity/Fan Control (4024125)**

BE SURE JUMPER WIRE BETWEEN  
RC & RH IS IN PLACE

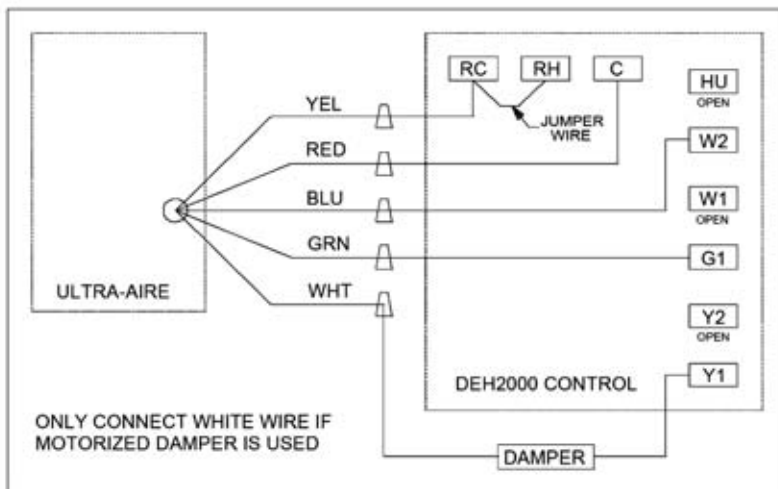

**UA-135H With DEH 2000 Digital Controller (4024539)**

# OPTIONAL PARTS LIST

Item	Part No.	Description
1	4024125	Control Panel Assembly, Ventilation Timer & Humidity Control
2	4024155	Control Panel Assembly, Humidity/Fan
3	4024539	DEH 2000 Digital Controller
4	4025287	Filter Box
5	4022220	Condensate Pump Kit, External
6	4024377	Optional External Insulation Kit (not shown)
7	4024369	2"x20"x24" Filter (not shown)
8	4024370	4"x20"x24" Filter (not shown)
9	4020646	10" Backdraft Damper (not shown)
10	4025463	Stand Kit (not shown)



**Item 1:** Ventilation Timer & Humidity Control



**Item 3:** DEH 2000 Digital Control

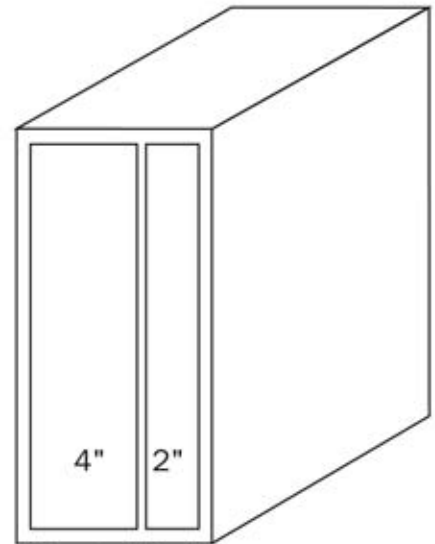

**Item 4:** Filter Box

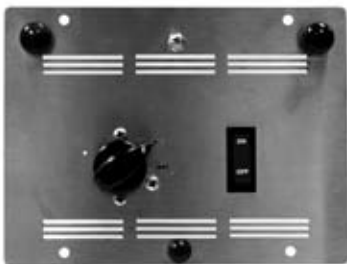

**Item 2:** Humidity/Fan Control

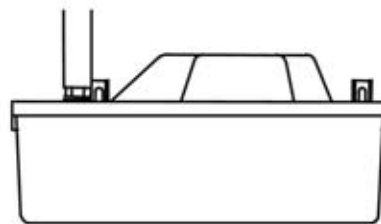

**Item 5:** Condensate Pump

# SERVICE PARTS LIST

Item	Part No.	Description
1	4021589	Capillary Tube, .059" X .124" X 28.00" (not shown)
2	4025075	Compressor, Carlyle (EBA105111A)
3	4025298	Compressor Overload (EBA105111A) (not shown)
4	4022484	Compressor Relay, SPST, 24 Vac, 30A
5	4025244	Compressor Run Capacitor, 30 MFD
6	4021396	Condenser Coil
7	4021470	Defrost Thermostat
8	4021648	Defrost Thermostat Mounting Clip (not shown)
9	4021395	Evaporator Coil
10	4025076	Impeller Fan
11	4020924	Impeller Fan Relay, SPDT, 24 Vac, 15A
12	4025224	Impeller Fan Run Capacitor, 15 MFD
13	4025087	Filter/Drier
14	4022219	Low Pressure Control (not shown)
15	4022487	Transformer, 120/24 Vac, 40 VA
not shown	4017414	Accumulator
not shown	4025249	Collar 10"
not shown	4024368	Collar 10" no crimp
not shown	4025082	Cord
not shown	4025084	Wire Harness
not shown	4025086	Wire Harness, low voltage
not shown	4025242	Wiring Diagram

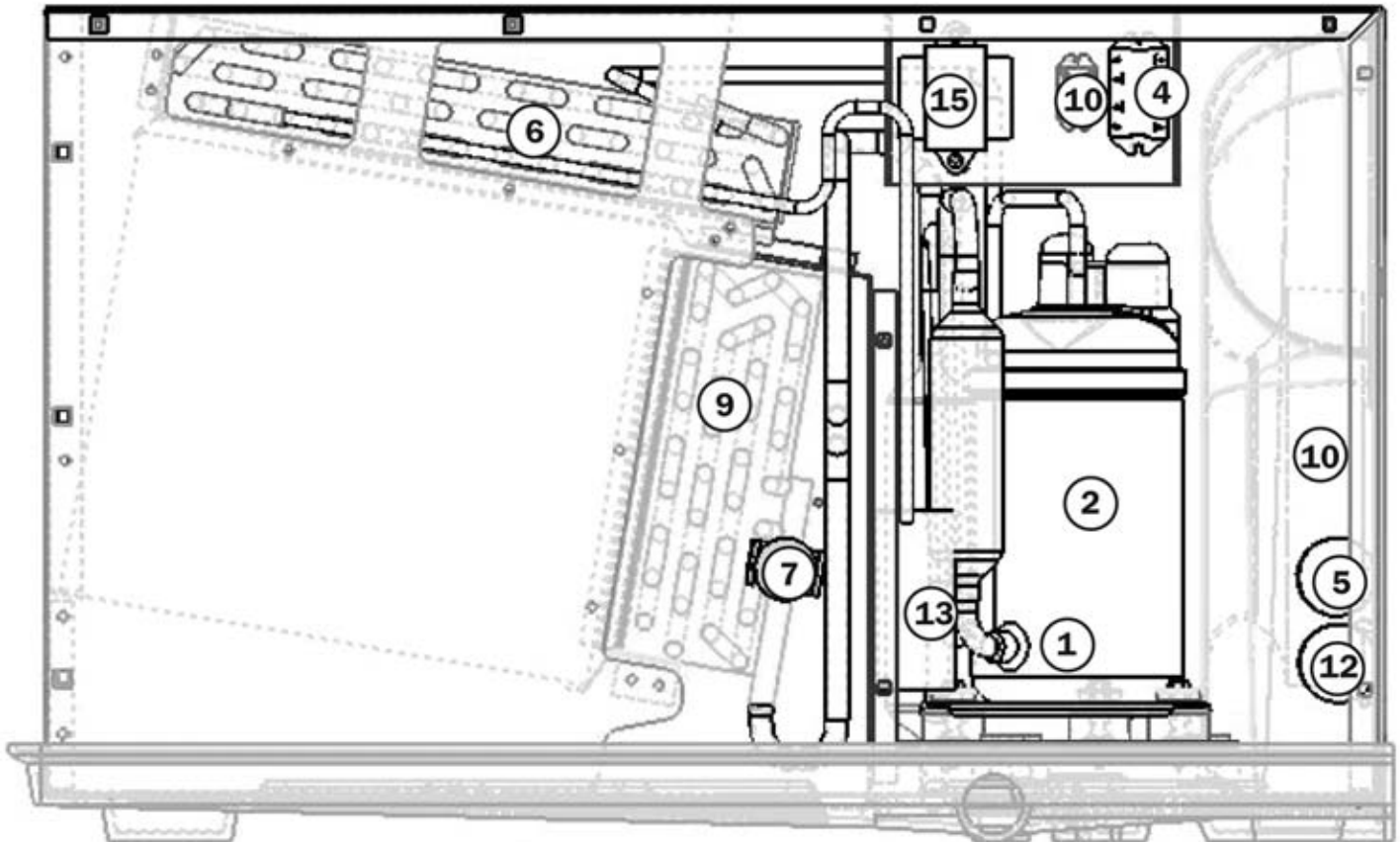

# ULTRA-AIRE 135H Dehumidifier Limited Warranty

## WARRANTOR:

Therma-Stor LLC  
PO Box 8680  
Madison, WI 53708

Telephone: 1-800-533-7533.

**WARRANTY:** This warranty covers the Ultra-Aire 135H Dehumidifier and extends only to the original residential end-user of the Ultra-Aire 135H Dehumidifier, and may not be assigned or transferred.

**Year One** - 100% parts and labor (all components). Therma-Stor LLC warrants that, for one (1) year the Ultra-Aire 135H Dehumidifier will operate free from any defects in materials and workmanship, or Therma-Stor LLC will, at its option, repair or replace the defective part(s), free of any charge.

**Year(s) Three through Five** - Therma-Stor LLC further warrants for a period of five (5) years, the condenser, evaporator, and compressor of the Ultra-Aire 135H Dehumidifier will operate free of any defects in material or workmanship, or Therma-Stor LLC, at its option, will repair or replace the defective part(s).

**USER RESPONSIBILITIES:** Warranty service must be performed by a servicer authorized by Therma-Stor LLC. To obtain warranty service you must obtain a return material authorization (RMA). To obtain an RMA you must present proof of purchase or (lease), by use of a warranty card, original sales receipt or other reasonable and reliable means.

To obtain an RMA call Therma-Stor LLC at the above number and ask for the Therma-Stor LLC Service Department, which will then issue an RMA# and arrange for, at our option, either repair or replacement.

**FREIGHT:** Freight to and from the servicer is the responsibility of the end-user. The end-user is responsible for normal care and proper return packaging.

**LIMITATIONS AND EXCLUSIONS:** This warranty does not cover any defect, malfunction, etc. resulting from misuse, abuse, lack of normal care, corrosion, freezing, tampering, modification, unauthorized or improper repair or installation, accident, acts of nature or any other cause beyond Therma-Stor LLC's reasonable control. If any Ultra-Aire 135H Dehumidifier part is repaired or replaced, the new part shall be warranted for the balance of original warranty (but all warranty periods will be extended by the period of time, if any, that the Ultra-Aire 135H Dehumidifier is out of service while awaiting covered warranty service).

Warranty service will be performed during normal working hours.

UPON THE EXPIRATION OF THE WRITTEN WARRANTY APPLICABLE TO THE ULTRA-AIRE DEHUMIDIFIER OR ANY PART THEREOF, ALL OTHER WARRANTIES IMPLIED BY LAW, INCLUDING MERCHANTABILITY AND FITNESS FOR A PARTICULAR PURPOSE, SHALL ALSO EXPIRE. ALL WARRANTIES MADE BY THERMA-STOR LLC ARE SET FORTH HEREIN, AND NO CLAIM MAY BE MADE AGAINST THERMA-STOR LLC BASED ON ANY ORAL WARRANTY. IN NO EVENT SHALL THERMA-STOR LLC, IN CONNECTION WITH THE SALE, INSTALLATION, USE, REPAIR OR REPLACEMENT OF ANY ULTRA-AIRE DEHUMIDIFIER OR PART THEREOF BE LIABLE UNDER ANY LEGAL THEORY FOR ANY SPECIAL, INDIRECT OR CONSEQUENTIAL DAMAGES INCLUDING WITHOUT LIMITATION WATER DAMAGE (THE END-USER SHOULD TAKE PRECAUTIONS AGAINST SAME), LOST PROFITS, DELAY, OR LOSS OF USE OR DAMAGE TO ANY REAL OR PERSONAL PROPERTY.

Some states do not allow limitations on how long an implied warranty lasts, and some do not allow the exclusion or limitation of incidental or consequential damages, so one or both of these limitation may not apply to you.

**LEGAL RIGHTS:** This warranty gives you specific legal rights, and you may also have other rights which vary from state to state.





**Therma-Stor<sup>®</sup> LLC**

PO Box 8680 • Madison, WI 53708

Phone: 608-222-5301 • Fax: 608-222-1447

Web: [www.thermastor.com](http://www.thermastor.com) • Email: [sales@thermastor.com](mailto:sales@thermastor.com)

*Information in this document is subject to change without notice. No part of this document may be reproduced or transmitted in any form or by any means, electronic or mechanical, for any purpose, without the express written permission of Therma-Stor LLC. © 2006 Therma-Stor LLC. All rights reserved.*

*Ultra-Aire 135H Installer's & Owner's Manual*

## Free Manuals Download Website

<http://myh66.com>

<http://usermanuals.us>

<http://www.somanuals.com>

<http://www.4manuals.cc>

<http://www.manual-lib.com>

<http://www.404manual.com>

<http://www.luxmanual.com>

<http://aubethermostatmanual.com>

Golf course search by state

<http://golfingnear.com>

Email search by domain

<http://emailbydomain.com>

Auto manuals search

<http://auto.somanuals.com>

TV manuals search

<http://tv.somanuals.com>