

Thermador[®]

Care and Use Manual

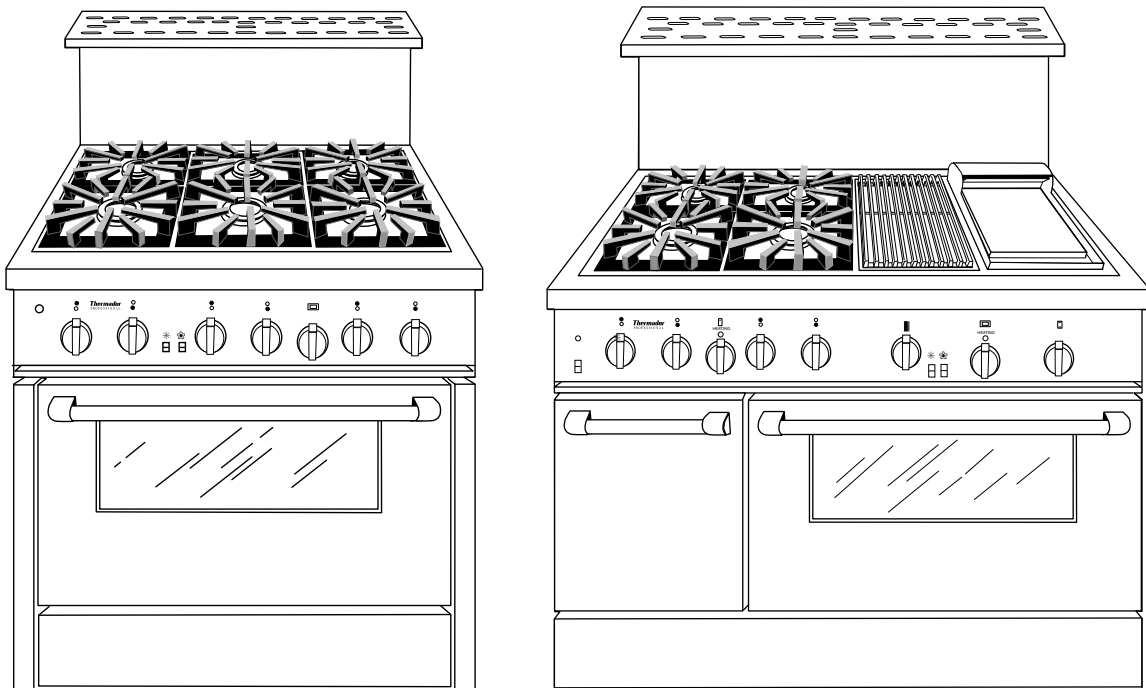

Thermador Professional[®] Range

FOR RESIDENTIAL USE ONLY

All-Gas Models PRG304

PRG364GL, PRG364GL, PRG366

PRG486GD, PRG486GL, PRG484GG

**LE MANUEL DE SOIN ET D'UTILISATION
EN ANGLAIS AVEC ADVERTISSEMENTS EN FRANÇAIS**

A Special Message to our Customers

Thank you for selecting the Thermador Professional[®] Range. We recommend that you take time to read this entire booklet before using your new appliance for the first time.

The booklet contains suggestions we believe will be helpful, as well as directions for using all the features of this range. Keep it in a handy place, as it has the answers to questions that may occur when you start to cook.

Let us know if we can help you. When you write, please include the model and serial numbers of your range.

Sincerely,

The Test Kitchen Consumer Scientists



WARNING:

If the information in this manual is not followed exactly, a fire or explosion may result causing property damage, personal injury or death.

FOR YOUR SAFETY

- ✓ **Do not store or use gasoline or other flammable vapors and liquids in the vicinity of this or any other appliance.**

AVERTISSEMENT

- ✓ **Ne pas entreposer ni utiliser de l'essence ni d'autres vapeurs ou liquides inflammables dans le voisinage de l'appareil, ni de tout autre appareil.**

WHAT TO DO IF YOU SMELL GAS

- Shut off gas to the appliance.
- Extinguish any open flame.
- Open Lid.
- If odor continues, immediately phone your gas supplier.
- If you cannot reach your gas supplier, call the fire department.

S'IL Y A UNE ODEUR DE GAZ:

- Coupez l'admission de gaz de l'appareil.
- Éteindre toute flamme nue.
- Ouvrir le couvercle.
- Si l'odeur persiste, appeler immédiatement votre compagnie de gaz ou votre département des incendies.

Table of Contents

If you Smell Gas Inside front cover

Introduction 1

Gas Type Verification..... 1

Introduction 2

SECTION ONE: General Safety Instructions

Safety 3

Precautions 4

SECTION TWO: Before You Begin

Before Using Your Range for the First Time 7

SECTION THREE: Description

Model & Parts Identification – PRG484GG 8

Model & Parts Identification – PRG486GD 9

Model & Parts Identification – PRG304 10

SECTION FOUR: Using the Cooktop

Using the Cooktop 13

Proper Cookware 13

Flame Setting Guidelines 15

Suggested Flame Settings 16

Using the Grill 18

Grill Cooking Chart 21

Using the Griddle 23

Griddle Cooking Chart 23

SECTION FIVE: Using the Oven

Bake 24

Convection•Bake 25

Other Uses of Bake 26

Setting Broil 27

SECTION SIX: Care and Maintenance

Burner Grates and Sealed Burners 29

Griddle and Grill 30

Range Cleaning Chart 31

SECTION SEVEN: Before Calling For Service

Do-It-Yourself Maintenance 35

Before Calling For Service 36

Data Rating Plate 36

Warranty Inside back cover

INTRODUCTION

The Thermador Professional® Ranges are free standing units available in a number of configurations. Model PRG304 is equipped with four sealed gas surface burners, a large capacity gas oven with convection system and gas infra-red broiler. Models PRG364GD, PRG364GL, and PRG366 feature a gas cooking surface with four sealed burners and a griddle, four sealed burners and a grill or six sealed burners, in addition to a large capacity gas oven with a convection system and a gas infra-red broiler. Models PRG484GG, PRG486GD, and PRG486GL feature a gas cooking surface with four sealed burners, griddle and grill; six sealed burners and a griddle; or six sealed burners and a grill. PRG48 Ranges provide a large gas oven (the same as used in the PRG36 Ranges) and a secondary gas oven with broil capability.

GAS TYPE VERIFICATION

Verify the type of gas supplied to the location. Ensure that the appliance is connected to the type of gas for which it is certified. All models are certified for use with natural gas. Field conversion of the appliance for use with propane gas requires Conversion Kit, P/N 35-00-549.

IMPORTANT

All ranges must be installed with a backguard. Model PRG304 is shipped from the factory with a standard 9" backguard. For all other models one of three available backguards must be ordered separately and installed at the back of the range. The three backguard choices include a Low Back, High Back Shelf, or Island Trim. Before using the range, insure that it is equipped with a proper backguard. Refer to the Installation Instructions accompanying this appliance for more information.



CAUTION:

When connecting the unit to propane gas, make certain the propane gas tank is equipped with its own high-pressure regulator in addition to the pressure regulator supplied with the range. **The maximum gas pressure to this appliance must not exceed 14.0 inches water column from the propane gas tank to the pressure regulator.**

Introduction

This manual contains important Care and Use information for All-Gas Thermador Professional® Ranges. When using this manual, it is critical that you know the model number of your range, as some information will be unique to each All-Gas Range. The model number may be found on the rating plate located on the range as identified on page 36 of this manual. The charts on the following pages summarize the various range models and identify the features of each All-Gas Range.



PRG All-Gas Ranges, Featuring a Gas Cooking Surface with Gas Ovens, with Gas Convection, and Gas Infra-Red Broiler

All-Gas PRG304	All-Gas, 30" wide Range with Four Cooktop Burners
All-Gas PRG364GD	All-Gas, 36" wide Range with Four Cooktop Burners and Griddle
All-Gas PRG364GL	All-Gas, 36" wide Range with Four Cooktop Burners and Grill
All-Gas PRG366	All-Gas, 36" wide Range with Six Cooktop Burners
All-Gas PRG484GG	All-Gas, 48" wide Range with Four Cooktop Burners, Griddle Grill and 2 ovens (1 large main and 1 small secondary)
All-Gas PRG486GD Griddle and 2 ovens (1 large main and 1 small secondary)	All-Gas, 48" wide Range with Six Cooktop Burners,
All-Gas PRG486GL	All-Gas, 48" wide Range with Six Cooktop Burners Grill and 2 ovens (1 large main and 1 small secondary)

TESTED IN ACCORDANCE WITH ANSI Z21.1 CURRENT ISSUE, STANDARD FOR HOUSEHOLD COOKING GAS APPLIANCES AND UL STANDARD 858 CURRENT ISSUE, HOUSEHOLD ELECTRIC RANGES. IN CANADA TESTED IN ACCORDANCE WITH CAN/CGA 1.1 DOMESTIC GAS RANGES, CURRENT ISSUE.

Check your local building codes for the proper method of installation. In the absence of local codes, this unit should be installed in accordance with the National Fuel Gas Code No. Z223.1 Current Issue and the National Electrical Code ANSI/NFPA No. 70 Current Issue or the Can - B149 Installation Codes for Gas Burning Appliances and C22.1 Canadian Electrical Code Part 1.

SAFETY

Electrical Requirements and Grounding Instructions

PLEASE READ CAREFULLY

All-Gas Models:

PRG304, PRG364GD, PRG364GL,
PRG366, PRG484GG, PRG486GD,
PRG486GL

120 volts, 60 Hz., 20 Amp electrical
circuit required.

**FOR PERSONAL SAFETY,
THIS APPLIANCE
MUST BE CONNECTED
TO A PROPERLY
GROUNDED AND PO-
LARIZED ELECTRICAL
POWER SUPPLY.**

ALWAYS DISCONNECT THE
ELECTRICAL PLUG FROM THE
WALL RECEPTACLE BEFORE
SERVICING THIS UNIT.

It is recommended that a dedicated
circuit servicing this appliance be
provided.

See Installation Instructions for electrical requirements
and grounding instructions.

CAUTION - ALL MODELS

**DO NOT UNDER ANY CIRCUMSTANCES CUT OR
REMOVE THE THIRD (GROUND OR NEUTRAL)
PRONG FROM THE POWER CORD PLUG (ALL-GAS
PRG RANGES).**

It is the personal responsibility and obligation of you, the user, to have
this appliance connected to the electrical power supply in accordance
with the National Electrical Code and/or applicable local codes and
ordinances by a qualified electrician.



CAUTION - ALL MODELS

In Case of an Electrical Failure

If for any reason a gas control knob is turned ON and there is no
electric power to operate the electronic igniters on the cooktop
burners, **turn OFF the gas control knob and wait 5 minutes**
for the gas to dissipate before lighting the cooktop burner manually.

To light the cooktop burners manually, carefully hold a lighted match
to the burner ports and turn the gas control knob to HI. During a
power failure you can use the cooktop burners, but each must be lit
with a match.

**DO NOT attempt to light the two left burners manually.
These burners are equipped with the ExtraLow® feature and
cannot be lit manually.**

NOTE: For PRG All-Gas Ranges, the gas oven and broiler burners
cannot be lighted manually during a power failure.

Safety Practices to Avoid Personal Injury

PRECAUTIONS

When properly cared for, your new Thermador Professional® Range has been designed to be a safe, reliable appliance. However, use extreme care when using this restaurant caliber range as this type of appliance provides intense heat and can increase the accident potential. When using kitchen appliances, basic safety precautions must be followed, including the following:

Read this Care and Use Manual carefully before using your new range to reduce the risk of fire, electric shock, or injury to persons.

Insure proper installation and servicing. Follow the installation instructions provided with this product. Have the range installed and grounded by a qualified technician.

Have the installer show you where the gas supply shut-off valve is located so that you know how and where to turn off the gas to the range.

If you smell gas, your installer has not done a proper job of checking for leaks. If the connections are not perfectly tight, you can have a small leak and therefore a faint gas smell. Finding a gas leak is not a “do-it-yourself” procedure. Some leaks can only be found with the burner control in the ON position and this must be done by a qualified service technician. See Inside Front Cover regarding gas leaks.

In the event a burner goes out and gas escapes, open a window or a door. Do not attempt to use the cooktop until the gas has had

time to dissipate. Wait at least 5 minutes before using the range.

Do not repair or replace any part of the appliance unless specifically recommended in this manual. All other servicing should be referred to a qualified technician.

Children should not be left alone or unattended in an area where appliances are in use. They should never be allowed to sit or stand on any part of the appliance.

CAUTION: Do not store items of interest to children above the range or at the back of it. If children should climb onto the appliance to reach these items, they could be seriously injured.

Never use any part of the cooktop or oven for storage. Flammable materials can catch fire and plastic items may melt or ignite.

Do not hang articles from any part of the appliance or place anything against the oven. Some fabrics are quite flammable and may catch on fire.

If the range is near a window, **be certain the curtains do not blow over or near the cooktop burners**; they could catch on fire.

DO NOT USE WATER ON GREASE FIRES. Turn appliance off and smother fire with baking soda or use a dry chemical or foam-type extinguisher.

Never let clothing, potholders, or other flammable materials come in contact with or too

close to any element, burner or burner grate until it has cooled. Fabric may ignite and result in personal injury.

Use only dry potholders: moist or damp potholders on hot surfaces may cause burns from steam. Do not use a towel or other bulky cloth in place of potholders. Do not let potholders touch hot burners, or burner grates.

For personal safety, wear proper apparel. Loose fitting garments or hanging sleeves should never be worn while using this appliance. Some synthetic fabrics are highly flammable and should not be worn while cooking.

Do not use aluminum foil to line any part of the oven or cooktop. Use of a foil liner could result in a shock or fire hazard, or the obstruction of the flow of combustion and ventilation air. Foil is an excellent heat insulator and heat will be trapped beneath it. This will upset the cooking performance and can damage the finish of the oven or the cooktop.



WARNING



TO REDUCE THE RISK OF TIPPING OF THE APPLIANCE, IT MUST BE SECURED BY A PROPERLY INSTALLED ANTI-TIP DEVICE. VERIFY THAT THE ANTI-TIP DEVICE IS ENGAGED PER INSTALLATION INSTRUCTIONS. (NOTE: ANTI-TIP DEVICE IS REQUIRED ON ALL 30" AND 36" RANGES.)

Safety Practices to Avoid Personal Injury

PRECAUTIONS

Warning: The appliance is for cooking. Based on safety considerations, never use the oven or cooktop to warm or heat a room. Also, such use can damage the cooktop or oven parts.

When using the cooktop: **DO NOT TOUCH THE BURNER GRATES OR THE IMMEDIATE SURROUNDING AREA.**

Areas adjacent to the burners may become hot enough to cause burns.

Never leave the cooktop unattended when using high flame settings. Boil overs cause smoking and greasy spillovers that may ignite. More importantly, if the burner flames are smothered, unburned gas will escape into the room. See Inside Front Cover regarding gas leaks.

Only certain types of glass, heat-proof glass-ceramic, ceramic, earthenware, or other glazed utensils are suitable for cooktop use. This type of utensil may break with sudden temperature changes. Use only on low or medium heat settings according to the utensil manufacturer's directions.

Do not heat unopened food containers; a buildup of pressure may cause the container to burst.

During cooking, **set the burner control so that the flame heats only the bottom of the pan and does not extend beyond the bottom of the pan.**

Use caution to insure that drafts like those from forced air vents or fans do not blow flammable material toward the flames or push the flames so that they extend beyond the edges of the pot.

Always use utensils that have flat bottoms, large enough to cover the burner. The use of undersized utensils could expose a portion of the flame and may result in ignition of clothing.

To minimize burns, ignition of flammable materials and unintentional spillovers, **position handles of utensils inward** so they do not extend over adjacent work areas, cooking areas, or the edge of the cooktop.

Hold the handle of the pan to prevent movement of the utensil when stirring or turning food.

DO NOT use pots or pans on the grill section.

Do not use the grill for cooking excessively fatty meats or products which promote flare-ups.

The optional cutting board accessory must be removed before operating the grill burner beneath or burners adjacent to it.

GREASE IS FLAMMABLE. Let hot grease cool before attempting to handle it. Avoid letting grease deposits collect. Clean after each use.

For proper lighting and performance of the burners, **keep the igniter ports clean.** It is necessary to clean these when there is a boil over or when the burner does not light even though the electronic igniters click. See page 12.

Clean the cooktop with caution. Avoid steam burns; do not use a wet sponge or cloth to clean the cooktop while it is hot. Some cleaners produce noxious fumes if applied to a hot surface. Follow directions provided by the cleaner manufacturer.

Be sure all cooktop controls are turned off and the cooktop is cool before using any type of aerosol cleaner on or around the cooktop. The chemical that produces the spraying action could, in the presence of heat, ignite or cause metal parts to corrode.

When using the oven: **DO NOT TOUCH THE INTERIOR SURFACES OF THE OVEN OR THE EXTERIOR AREA IMMEDIATELY SURROUNDING THE DOOR.** Interior oven surfaces become hot enough to cause burns. The heat deflector, which deflects heat away from the cooktop and the trim on the top and sides of the oven door, will also be hot when the oven is in use.

Place oven racks in desired position while oven is cool. If a rack must be moved while the oven is hot, do not let the potholders contact the hot infrared burner.

Use care when opening the oven door; let hot air or steam escape before removing or replacing foods.

Do not rub, damage, move or remove the door gasket. It is essential for a good seal during baking.

Be careful not to damage the screen covering the infra-red broiler of the gas oven. If the screen is damaged, air can enter the distribution box behind the screen, possibly resulting in an explosion.

In the event that personal clothing catches fire, DROP AND ROLL IMMEDIATELY to extinguish flames.

PRECAUTIONS

DONOT obstruct the flow of combustion or ventilation air.

For safety reasons and to avoid equipment damage, never sit, stand, or lean on the oven door.

Service should only be done by authorized Technicians. Technicians must disconnect the power supply before servicing this unit.

Clean the ventilator hood and filters above the range frequently so grease from cooking vapors does not accumulate on them.

Turn the ventilator OFF in case of fire or when intentionally “flaming” liquor or other spirits on the cooktop. The blower, if in operation, could unsafely spread the flames.

California Proposition 65 WARNING:

The burning of gas cooking fuel generate some by-products which are on the list of substances which are known by the State of California to cause cancer or reproductive harm. California law requires businesses to warn customers of potential exposure to such substances. To minimize exposure to these substances, always operate this unit according to the instructions contained in this booklet and provide good ventilation to the room when cooking with gas.

SAVE THESE INSTRUCTIONS BEFORE USING YOUR RANGE FOR THE FIRST TIME, CHECK THAT YOU HAVE THESE ITEMS:

DESCRIPTION	PRG 304 GD	PRSG 364 GL	PRG 364	PRG 366 GD	PRG 486 GL	PRG 486 GG	PRG 484
Oven Racks Large Oven	2**	2**	2**	2**	2**	2**	2**
Oven Racks 12" Oven					2	2	2
Two-Piece Broil Pan	1	1	1	1	2‡	2‡	2‡
Burner Caps	4	4	4	6	6	6	4
Burner Grates	4	4	4	6	6	6	4
Control Knobs	5	6	6	7	9	9	8
Cast Iron Grill Grate			1			1	1
Stainless Steel Radiant			1			1	1
Steel Griddle		1			1		1
Product Registration Card	1	1	1	1	1	1	1
Backguard	1	*	*	*	*	*	*
Installation Instructions	1	1	1	1	1	1	1

*Backguard must be ordered and shipped separately. It is not included with the range shipment. **One rack is a special Broil Rack. ‡The aluminum broil pan is for the Secondary Oven; the porcelain & chrome broil pan is for the Main Oven.

Before Using Your Range for the First Time

Remove all packaging materials and temporary labels from oven and cooktop.

RACK POSITIONS

**Large All-Gas Main Oven
(PRG304, PRG36 and
PRG48 Models)**

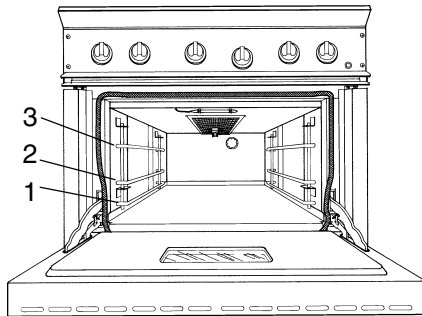

**All-Gas Secondary Oven
(PRG48 Models only)**

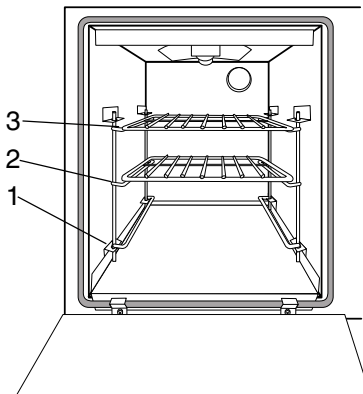

1. Check that you have the items listed on Page 6.
2. **Record the Model and Serial number as described on Page 36 see "Data Rating Plate."** These may be used for any future contacts with your servicer or the factory. Enter this information on the Product Registration Card included with this product; then mail it to the indicated address to receive your free Thermador Professional® Cookbook.
3. **Optional Accessories.** Grill Cover, Chopping Board, Griddle, and other accessories are available from your Thermador Dealer. Contact the Thermador Parts Department toll-free at 800/735-4327 for more information.
4. Position the racks correctly in the oven.

The correct rack position depends on the recipe and the cooking mode. **The rack positions are numbered from the bottom of the oven, like an elevator.** Rack position 2 is the most frequently used position. Place rack(s) in the proper position before turning on the oven. For all models insert and remove racks as follows:

Insert the racks as follows:

- a. Hold the rack with the back rail in the up position towards the rear of the oven. Slip it into the oven so the rack slides are between the rack and the rack guides.
- b. Tip the front of the rack up slightly as it slides into the oven so that the safety stops clear the rack slides. The safety stops on the back of the rack will keep it from sliding out of the oven when it is pulled forward.

Remove or reposition the racks as follows:

- a. Pull the rack forward,
- b. Lift the front of the rack up so the safety stops clear the rack slides.
- c. Pull the rack forward to remove.

Caution

Aluminum foil should never be used to cover the oven racks or to line the oven. It may cause damage to the oven if it touches the infrared broiler or when heat is trapped beneath it.

Before baking or broiling for the first time, the oven and broiler should be turned on separately to burn off the manufacturing oils. Turn the oven on to 450°F. for 20 to 30 minutes; then turn the broiler to "Broil" for same length of time. You may wish to turn on the ventilator above your range during this time.

Please read Page 34 in Section 6: Care and Maintenance **before** cleaning the oven racks.

Model and Parts Identification

All-Gas Model PRG484GG — Shown

Model PRG486GD - Grill, Item 3, replaced by Griddle, Item 4; Griddle, Item 4, replaced by Burner Grates and Burners, Item 2. Grill Thermostat Control Knob, Item 8, replaced by Griddle Control Knob, Item 9; Griddle Thermostat Control Knob, Item 9, replaced by Standard Burner Control Knobs, Item 7.

Model PRG486GL - Griddle, Item 4, replaced by Burner Grates and Burners, Item 2. Griddle Thermostat Control Knob, Item 9, replaced by Standard Burner Control Knobs, Item 7.

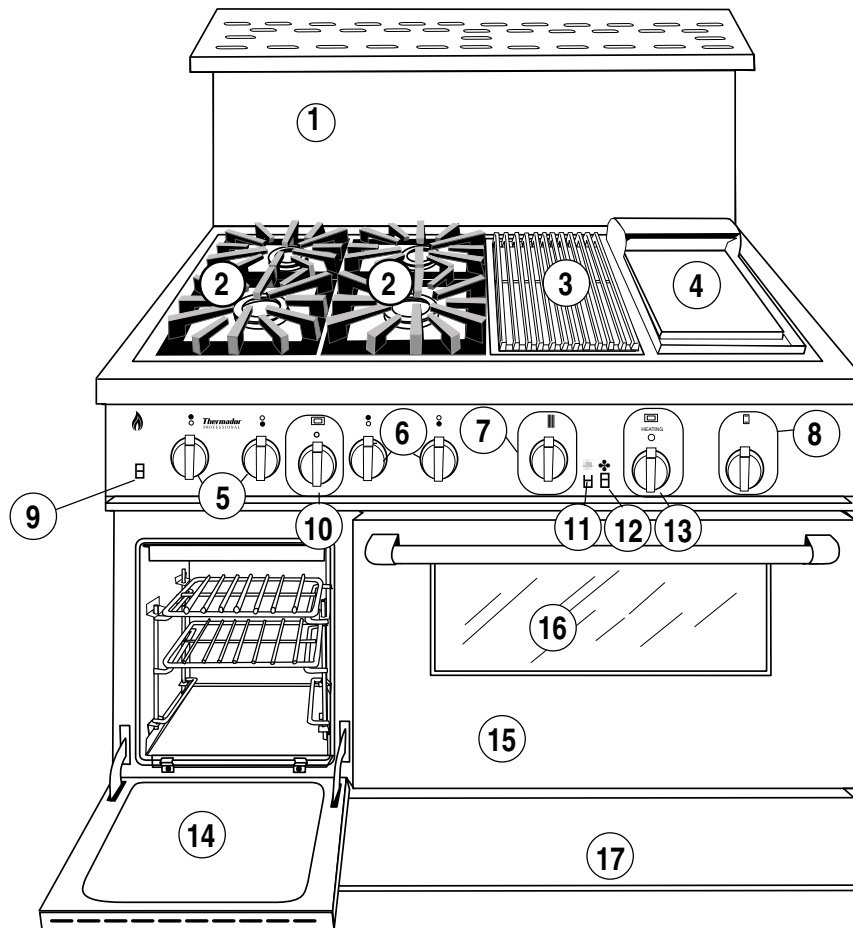

Secondary Oven

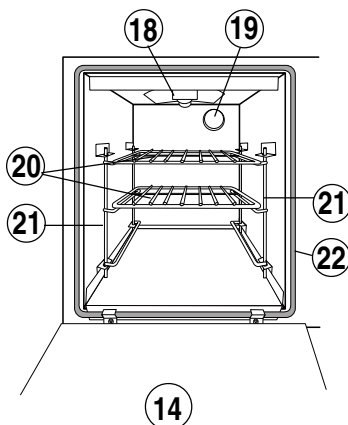

Key for PRG48 and PRG36 Models

- | | |
|--|--|
| 1. 22-inch High Shelf Backguard, 12-inch Low Back, or Island Trim (Backguard ordered separately) | 9. Light Switch, Secondary Oven |
| 2. Burner Grates & Burners (15,000 BTU Each) | 10. Oven Controls and Heating Light, Secondary Oven |
| 3. Grill (18,000 BTU) | 11. Light Switch, Large Main Oven |
| 4. Griddle (15,000 BTU) | 12. Convection Switch, Large Main Oven |
| 5. Control Knobs, ExtraLow® Burners | 13. Oven Control and Heating Light, Large Main Oven |
| 6. Control Knobs, Standard Burners | 14. Secondary Oven door (for inside, see additional picture at the left) |
| 7. Control Knob, Grill | |
| 8. Control Knob, Griddle Thermostat | |

Model and Parts Identification

All-Gas Model PRG364GD — Shown

Model PRG364GL - Griddle, Item 3, replaced by Grill, Item 4, and Griddle Thermostat Control Knob, Item 9, replaced by Grill Control Knob, Item 8.

Model PRG366 - Griddle, Item 3, replaced by Burner Grates and Burners, Item 2, and Griddle Thermostat Control Knob, Item 9, replaced by Standard Burner Control Knobs, Item 7.

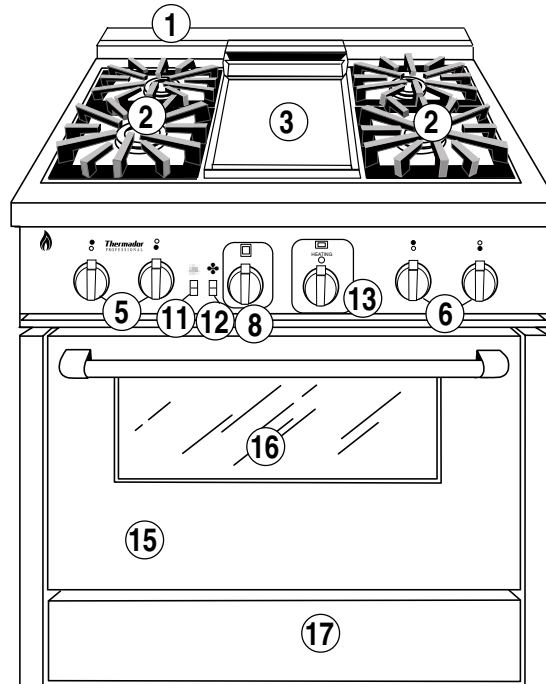

Key for PRG48 and PRG36 Models (continued)

- 15. Large Oven Door
- 16. Viewing Window, Large Oven
- 17. Kick Panel (Product Rating Label Located Behind Kick Panel)
- 18. Broil Burner, Secondary Oven
- 19. Oven Interior Light: (One in Each Oven)
- 20. Oven Racks: (Two in Each Oven)
- 21. Rack Guides (Removable in Both Ovens)
- 22. Oven Door Gasket
- 23. Convection Fan
- 24. Thermostat tube
- 25. Infra-Red Broiler (Large Oven)
- 26. Convection Fan Cover
- 27. Door Vents

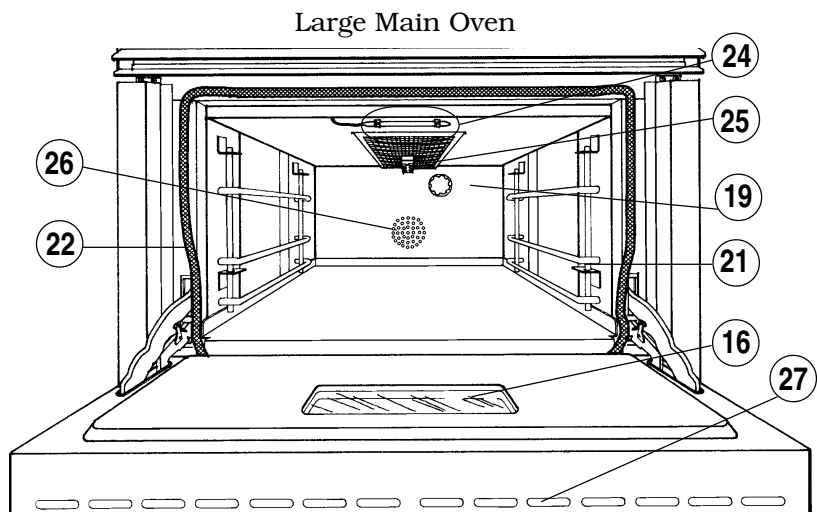

Model and Parts Identification

All-Gas Model PRG304 - Shown

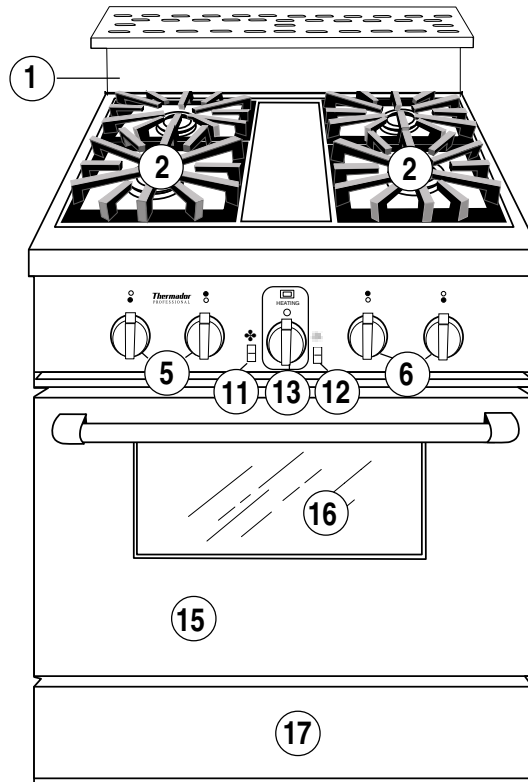

Key for PRG Models

- | | |
|---|---|
| 1. 22" High Shelf Backguard,
12" Low Back, or Island Trim
(Each ordered separately) | 14. Secondary Oven door (for inside, see additional
picture at the left) |
| 2. Burner Grates & Burners | 15. Large Oven Door |
| 3. Grill | 16. Viewing Window, Large Oven |
| 4. Griddle | 17. Kick Panel (Product Rating Label Located Behind
Kick Panel) |
| 5. Control Knobs, ExtraLow® Burners | 18. Broil Burner (Secondary Oven) |
| 6. Control Knobs, Standard Burners | 19. Oven Interior Light: (One in Each Oven) |
| 7. Control Knob, Grill | 20. Oven Racks: (Two in Each Oven) |
| 8. Control Knob, Griddle Thermostat | 21. Rack Guides (Removable in Both Ovens) |
| 9. Light Switch, Secondary Oven | 22. Oven Door Gasket |
| 10. Controls, Secondary Oven | 23. Convection Fan |
| 11. Convection Switch, Large Main Oven | 24. Thermostat tube |
| 12. Light Switch, Large Main Oven | 25. Infra-Red Broiler (Large Main Oven) |
| 13. Oven Control Knob, Large Main Oven and Heating
Light | 26. Convection Fan Cover |
| | 27. Door Vents |

Using the Cooktop

SEALED BURNERS

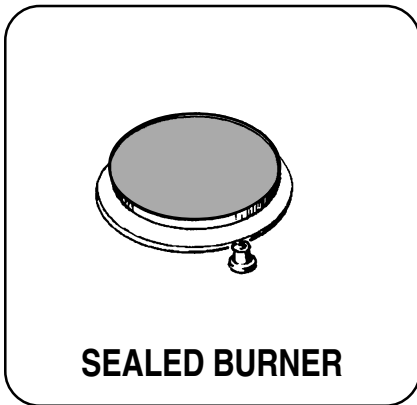

SEALED BURNER

The cooktop features four or six gas surface burners, each rated at 15,000 BTU/HR. The burners are sealed to the metal top frame to prevent liquid spills from penetrating below the top surface, thereby facilitating cleaning. On all models, the two far left burners are equipped with the exclusive ExtraLow® feature, which cycles the flame off and on to achieve the lowest possible simmer rate. Each burner is controlled by an individual control knob connected to a shaft of a gas valve.

BURNER CAPS

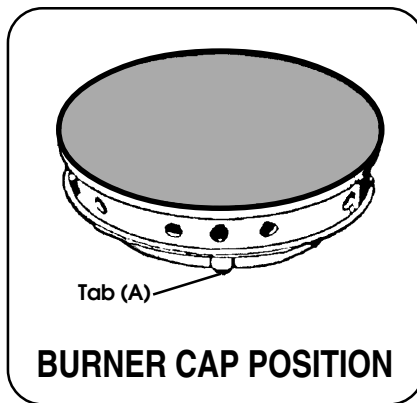

BURNER CAP POSITION

The Burner Cap top is porcelain enamel and has a tab (A) on the underside that fits into the notch (B) on the burner base (C).

BURNER BASE

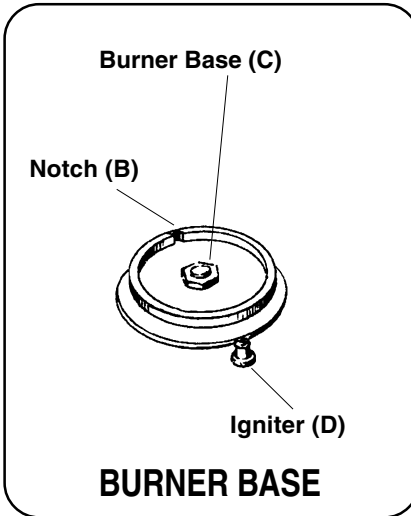

BURNER BASE

NOTE: For safe and proper burner operation, be sure that tab (A) on the underside of the burner cap fits into the corresponding notch (B) on the burner base.

CONTROL KNOBS

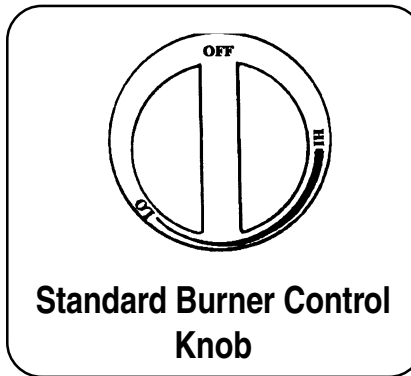

Standard Burner Control Knob

The control knobs for the sealed gas burners are positioned directly in front of and below the corresponding burners. There are indicator marks located above each knob that identify whether the knob controls the front or rear burner. A solid circle indicates that the knob controls that burner; an open circle indicates that the knob controls the opposite burner. To operate a burner, press the desired control knob, then rotate it counterclock-

wise to the HI position. The igniters at all of the sealed surface burners will click, then the selected burner will light. After flame ignition, the igniters will stop clicking. The knob can then be rotated to any position between HI and LO to achieve the desired flame height. For the standard burners, the LO setting is equivalent to 2,200 BTU/HR and HI is equivalent to 15,000 BTU/HR.

NOTE: Whenever any control knob for the sealed surface burner is turned beyond the OFF position, the surface burner indicator light located on the far left of the control panel will illuminate.

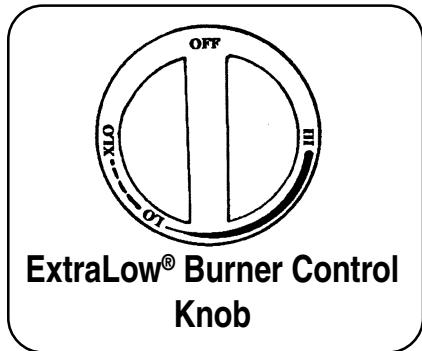

ExtraLow® Burner Control Knob

For the two far left ExtraLow® burners, the corresponding control knobs have additional markings indicating that rotation of the knob below the LO setting is possible. Within this LO to XLO control range, the flame is pulsed OFF and ON for varying lengths of time to enable simmering, poaching, melting chocolate and holding cooked foods at temperature without scorching or burning. The XLO setting is equivalent to 375 BTU/HR and is achieved by cycling the flame ON for approximately 10 seconds and OFF for 50 seconds of each minute. At a position just below the LO setting, the flame will be ON for approximately 50 seconds and OFF for 10 seconds of each minute, resulting in an output of 1,850 BTU/HR.

Using the Cooktop

THINGS TO CONSIDER WHEN SETTING AND ADJUSTING CONTROL KNOBS

- The type and quantity of the food will affect which setting to use.
- The size, type and material of your pan will affect which setting to use.
- Temperature control will be more accurate if a lid is used.
- Bring food to a rolling boil; stir well to be sure all the food is boiling; cover and reduce the heat to just below **LO**.
- Check periodically to see if the control knob should be turned to a lower setting.
- When a large pan is used on a small burner, it may cause the simmer action to occur mainly in the center of the pan. When the food is stirred, the cooler food near the edges of the pan may result in an overall temperature too cool to simmer. If this happens, turn the burner up slightly.
- It is normal to stir food occasionally. This is especially important when simmering for several hours. For example: a homemade spaghetti sauce or beans.
- Adjust control knob to lower settings in small steps.
- If control is set too low to maintain simmer, bring the food back to a boil before setting to a higher simmer setting.
- It is normal not to see simmer bubbles immediately after the food has been stirred.
- While the flame is **ON** there may be bubbling; there should be at least steam and a slight quiver of the liquid's surface.
- Simmer bubbles may not be seen when the flame has cycled **OFF**.

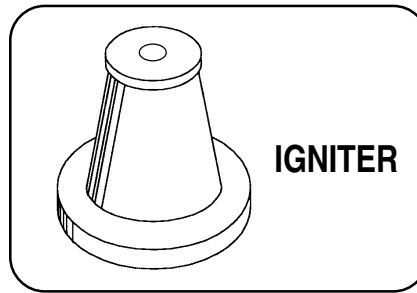

IGNITER

ELECTRONIC IGNITION

The cooktop uses electronic igniters to light the burners. Each burner has its own igniter that sparks when any burner is turned on. When the igniters are clicking (sparking), do not touch the burners. If a burner fails to ignite, see "Before Calling for Service", page 36.

AUTOMATIC REIGNITION

If any burner flame blows out, the electronic igniter automatically sparks on **all** burners to relight the flame. **Do not touch any burner while the igniters are clicking.**

POWER FAILURE

In the event of a power failure, only the standard burners can be lighted manually. It is necessary to light each standard burner individually.

If the cooktop is being used when the power failure occurs, turn all the burner control knobs to the **OFF** position. Then the standard burners can be lighted by holding a match at the ports and turning the control knob to the **HI** position. Wait until the flame is burning all the way around the burner cap before adjusting the flame to the desired height.

The two ExtraLow[®] burners located on the far left side cannot be used during a power failure. Be sure to turn them **OFF** if a power failure occurs, as they will not turn back on

until both control knobs are turned OFF and then turned back on again. See "What To Do If You Smell Gas," inside front cover.

NOTE: For PRG All-Gas Ranges, the gas oven and broiler burners cannot be lighted manually during a power failure.

The Griddle in all units can not be used during a power failure..

FLAME HEIGHT

The correct height of the flame depends on the size and material of the utensil being used, the food being cooked and how much liquid is in the utensil. Here are some basic rules for selecting the flame height.

- The flame should never extend beyond the bottom of the pan.
- Utensils which conduct heat slowly (such as glass-ceramic) should be used with a low or medium flame unless you are cooking with a large amount of liquid

BURNER EFFICIENCY and FLAME CHARACTERISTICS

The burner flame should be blue in color and stable with no yellow tips, excessive noise or fluttering. It should burn completely around the burner cap.

Foreign particles in the gas line may cause an orange flame during initial use. This should disappear with use. If the flame does not burn evenly

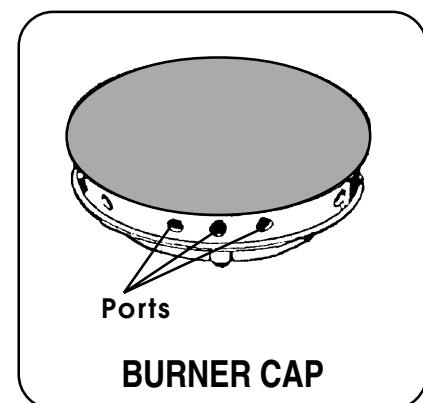

Ports

BURNER CAP

Using the Cooktop

all the way around the burner cap, be sure the cap is positioned correctly on the burner base.

If the ports are clogged, use a wire, a straightened paper clip or a needle to clear the ports. **Do not use a toothpick; it could break off inside the port.** If the condition persists, contact a service agency for adjustment.

The burner should light in 4 seconds or less. If a burner does not light, check to see that the cap is positioned correctly on the burner base.

RETAINED HEAT

Due to the heavy mass of this professional range, heat will be retained by the grates, burners, and top frame.



CAUTION

- **Foods packaged in aluminum foil** should not be placed directly on the burner grate for cooking: aluminum foil can melt.
- **Plastic, paper and cloth can melt or burn** when in contact with a hot burner grate. Do not let these items come into contact with the burner grate.
- **Do not allow pans to boil dry.** This can damage the pan, the burner grate, the metal top frame and/or the burner cap and base.
- **Heavy grates retain heat** long after flame has been turned off. Be careful when removing.

IMPORTANT

- FOR PROPER COMBUSTION DO NOT USE THE COOKTOP WITHOUT THE BURNER GRATES IN PLACE.
- IT IS NORMAL FOR A SLIGHT “POP” OR “FLASH” TO OCCUR AT THE BURNER PORTS A FEW SECONDS AFTER THE BURNER HAS BEEN TURNED OFF. THIS WILL ALSO OCCUR WHEN THE FLAME IS TURNED OFF AUTOMATICALLY IN THE EXTRALOW® MODE OF OPERATION.

Proper Cookware

Top performance of your new cooktop is directly related to the use of proper pots and pans. An out-of-shape pan, without a lid, cannot possibly cook with the same speed and evenness as a pan with a heavy, flat bottom and a good fitting lid.

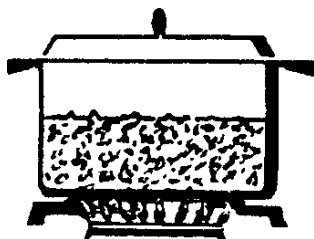

FLAT



CONVEX (rounded)

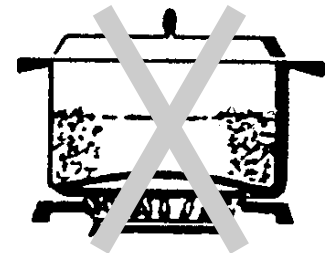

CONCAVE (hollow)

Proper Cookware

PANS

For best results on the cooktop, we recommend using Professional Cookware. This type of utensil can be found at Resturant Supply Stores. If using regular cookware on this cooktop, be very careful if the pans have plastic handles, as the large professional size burners could flame up on the outside of the pan and melt or bubble the handles.

Cookware should have the following characteristics:

- ▲ Good heat conductivity
- ▲ Bottom diameter matching the size of the burner used
- ▲ Good balance (pan bottom remains level on burner grate)
- ▲ Smooth, heavy bottom that does not warp when hot; provides even heat
- ▲ Proper fitting lid (when needed for specific cooking methods)

Do not use cookware with these characteristics:

- ▲ Thin bottom
- ▲ Concave bottom when heated
- ▲ Convex bottom when heated
- ▲ Poor balance (rocks back from weight of handle)

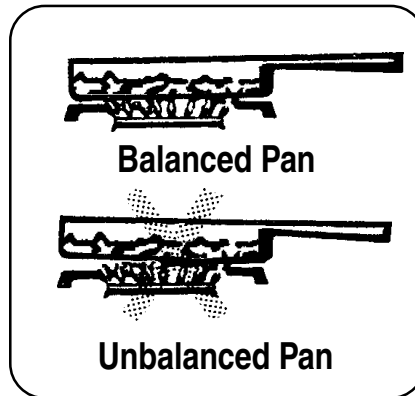

Use balanced pans that sit level on the burner grate without tilting from the weight of the handle.

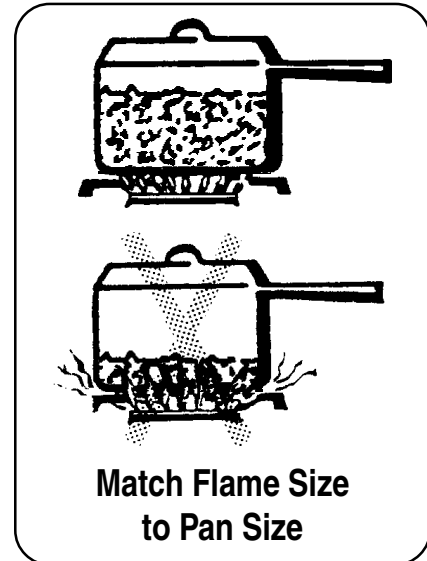

Match the flame to the bottom diameter of the pan. The flame should be the same size as the pan or slightly smaller. Small utensils and high flames result in energy loss and increase the potential for burns.

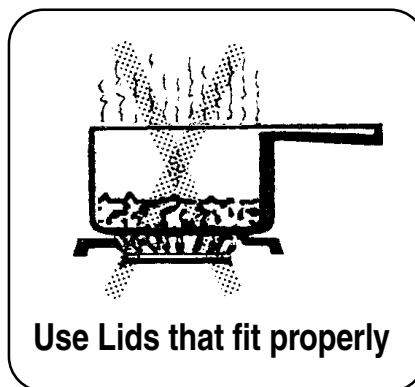

Use lids that fit the cookware properly to help shorten cooking time and to allow food to cook in a minimum amount of liquid on a lower heat setting.

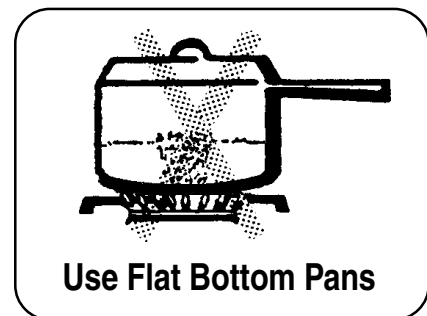

Use flat, heavy bottom pans that stay flat when heated for the best results. Avoid cookware that is warped, dented, ridged or thin. A warped or ridged pan receives the most heat at the point(s) that contact the flame. This can result in burning or scorching of the food being prepared.

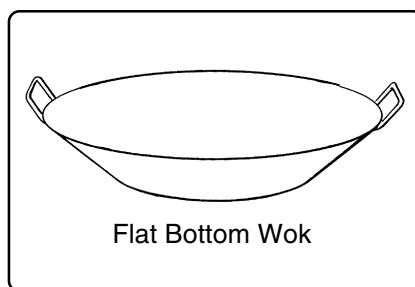

Use only a flat bottom wok. A round bottom wok cannot be used with or without its support ring. The wok is unstable without the ring, and the ring may restrict air to the burners.

Heat and cool pans gradually to help maintain a flat bottom on your cookware. Do not place pans under cold water while still hot, unless recommended by the manufacturer, as they may warp.

Proper Cookware

Use canners and stock pots that have a flat bottom and extend no more than 2 inches beyond the burner grate.

Canning Tips:

- ▲ An oversize canning pot can be used with success following these suggestions.
- ▲ Use a canner with a dark or dull finish to reduce heat reflecting back to the cooktop surface.
- ▲ Select a canner with a flat bottom, rather than one with a concave, convex or rippled bottom.

- ▲ Allow at least 3/8 inch of air space between the canner overhang and the cooktop surface.
- ▲ Use the lowest heat setting possible to maintain a boil or pressure.
- ▲ Be sure to cover all containers.
- ▲ Follow the canning instructions given in a standard cookbook or manufacturer's instructions provided with the canning jars

▲ Use care to prevent burns from the large amount of steam generated by the canning process.

Look for canners fitting this description:

- ▲ Water Bath Canner: Standard 21 to 22-quart canners with an 11 to 12-inch diameter and a 9 to 11-inch depth.
- ▲ Pressure Canner: Canners vary in size from 8 to 22 quarts with 8 to 11-inch bottom diameters and a 6-1/2 to 12-inch depth.

Flame Setting Chart Guidelines

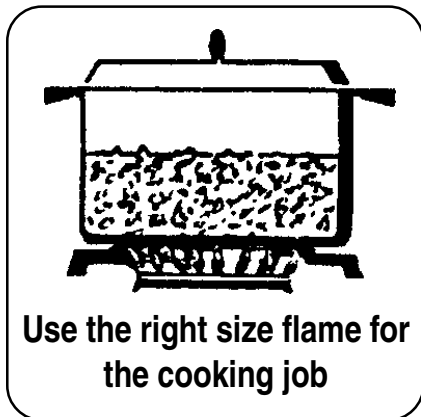

The Flame Setting Chart, on pages 16 and 17, is to be used as a guide. Your pans and your manner of cooking may dictate use of a different setting than what is suggested. **All flame settings were determined using a variety of good quality, flat bottom pans with lids** (unless the method of cooking did not require a covered pan). The flame was matched to the size of the pan and the method of cooking:

How to Use the Chart

The chart is divided into two sections: the food and the flame settings. The flame settings section shows an initial **Start Cooking** setting, a second **Continue Cooking** setting and/or an **ExtraLow® Heat** setting. There may or may not be a change between the two **Start Cooking** and the **Continue Cooking** settings depending on the food prepared. The **ExtraLow®** setting can be either a cooking or a holding setting.

ExtraLow® Burners

Medium

All the controls have an infinite number of heat settings, with no fixed positions between **HI**, **LO** or **XLO**. The word (Medium) and number designations are for reference only and are guides to the flame settings referenced in the chart.

Guidelines:

1. The actual flame setting used to cook is selected from the range of flame settings given. Whether the higher or lower setting is selected depends on the quality of the pan and the amount of food.
2. Raise or lower the flame setting gradually. Allow time for the pan and food to adjust to the new setting. Changes are more satisfactory when the setting is only changed one or two markings on the control.

Suggested Flame Settings

Before using this chart read page 15

Food	Start Cooking	Continue Cooking	ExtraLow® Heat Settings
BEVERAGES Cocoa	Med. – heat milk, cover	LO – finish heating	XLO – keep warm, cover*
BREADS French Toast, Pancakes, Grilled Sandwiches	Med. – preheat skillet	Med. Lo to Med. – cook	
BUTTER			4 to 3 – allow 5 to 10 minutes to melt XLO – to hold
CEREALS Cornmeal, Grits, Oatmeal	HI – cover, bring water to a boil, add cereal	Med. Lo to Med. – finish cooking according to package directions	XLO – to hold, cover*
CHOCOLATE			2 to XLO – allow 10 to 15 minutes to melt XLO – to hold*
DESSERTS Candy	Med. Lo to Med. – cook following recipe	Med. Lo to Med.	
Pudding and Pie Filling Mix	Med. to Med. Hi – cook according to package directions	Med. to Med. HI	
Pudding	Med. Lo – Bring milk to a boil		3 to 2 – to cook
EGGS Cooked in Shell	HI – cover, bring water to a boil, add eggs, cover		XLO – cook 3 to 4 minutes for soft cooked; or 15 to 20 minutes for hard cooked
Fried, Scrambled	Med. to Med. Hi – melt butter, add eggs	LO to Med. Lo – finish cooking	XLO – to hold for a short period*
Poached	HI – bring water to the steaming point, add eggs		4 to 3 – finish cooking
MEAT, FISH, POULTRY Bacon, Sausage Patties	HI – until meat starts to sizzle	Med. Lo to Med. – finish cooking	
Braising: Swiss Steak, Pot Roast, Stew Meat	HI – melt fat, then brown on Med. Hi to HI , add liquid, cover		3 to 2 – simmer until tender
Quick Frying: Breakfast Steaks	Med. Hi to HI – preheat skillet	Med. Hi to HI – fry quickly	
Frying: Chicken	HI – heat oil, then brown on Med.	LO – cover, finish cooking	
Deep Frying: Shrimp	HI – heat oil	Med. Hi to HI – to maintain temperature	
Pan Frying: Lamb Chops, Thin Steaks, Hamburgers, Link Sausage	HI – preheat skillet	Med. to Med. HI – brown meat	4 to 3 – to hold, covered 3 to 2 – to hold, uncov- ered
Poaching: Chicken , whole or pieces, Fish	HI – Cover, bring liquids to a boil		2 to 1 – to finish cooking

Suggested Flame Settings

Food	Start Cooking	Continue Cooking	ExtraLow® Heat Settings
Simmering: Stewed Chicken, Corned Beef, Tongue, etc.	HI – cover, bring liquid to a boil		4 to 1 – simmer slowly
PASTAS: Macaroni, Noodles, Spaghetti	HI – bring water to a boil, add pasta	Med. Hi to HI – to maintain a rolling boil	
POPCORN (use a heavy, flat bottom pan)	HI – cover, heat until kernels start to pop	Med. to Med. Hi – finish popping	
PRESSURE COOKER Meat	Med. Hi to HI – build up pressure	Med. Lo to Med. – maintain pressure	
Vegetables	HI – build up pressure	Med. Lo to Med. – maintain pressure	
RICE	HI – cover, bring water to a boil, add rice, cover		4 to 2 – cook according to package directions XLO – to hold, cover
SAUCES Tomato Base	Med. Hi to HI – cook meat vegetables, follow recipe		2 to XLO – simmer (2 to 3 to thicken sauce, uncovered)*
White, Cream, Bernaise, Hollandaise	Med. Lo – melt fat, follow recipe	LO to Med. Lo – finish cooking	XLO – to hold, cover*
SOUPS, STOCK	HI – cover, bring liquid to a boil		3 to 2 – simmer XLO – to hold, cover*
VEGETABLES Fresh	HI – cover, bring water and vegetables to a boil	Med. Lo to Med. – cook 10 to 30 minutes, or until tender	XLO – to hold, cover
Frozen	HI – cover, bring water and vegetables to a boil	Med. Lo to Med. – cook according to package directions	
Deep Frying	HI – heat oil	Med. to Med. Hi – maintain frying temp.	
In Pouch	HI – cover, bring water and vegetables to a boil	LO to Med. Lo – cook according to package directions	
Saute	HI – heat oil or melt butter; add vegetables	Med. Lo to Med. – cook to desired doneness	
Stir Fry	HI – heat oil, add vegetables	Med. Hi to HI – finish cooking	

* We recommend that these foods be stirred occasionally.

Using the Grill

A VENTILATING HOOD of adequate CFM capacity vented to the outside of the house is recommended for installation **ABOVE THE RANGE AND GRILL**. For most kitchens with a wall mounted hood, a certified hood rating of not less than 940 CFM is recommended. The hood must be installed according to installation instructions furnished with the hood and local building code requirements.

THE GRILL

(Available on some models)

When cooking food on the grill you will achieve the same flavor as meat cooked on an outdoor barbecue.

This flavor is actually created by the fats and juices that are brought to the surface of the food and caramelized by the intense heat from the stainless steel radiant.

Most types of foods, steaks, chops, patties, poultry pieces, etc., cook somewhat faster on the gas grill with its constant regulated heat than on an ordinary charcoal grill.

Your new Thermador Professional® grill is equipped with an aluminized steel double U-shaped tube burner typical of those used in restaurants. Automatic ignition is used to eliminate the continuous pilots found on restaurant grills. The grill burner is rated at 18,000 BTU/HR.

NOTE: When used with propane gas, a slight pop or flash may occur at the burner ports a few seconds after the burner has been turned off. This usually occurs after the burner has been on awhile. This is normal.

AUTOMATIC REIGNITION

The electronic igniter automatically sparks the burner to light. **DO NOT TOUCH** any burner while the igniters are sparking.

BURNER EFFICIENCY AND FLAME CHARACTERISTICS

The burner flame should be blue in color and stable with no yellow tips, excessive noise or lifting. It should burn completely along both sides of the burner tube.

An improper gas-air mixture may cause either a yellow tipped flame or burner flutter. Have the flame adjusted by a technician. Foreign particles in the gas line may cause an orange flame during initial use. This will disappear with use.

If the flame is uneven, flutters, makes excessive noise or lifts, check to see if the BURNER ports are clogged. If the ports are clogged, use a wire, a straightened paper clip or needle to clear the ports. If the condition persists, contact a service agency for adjustment.

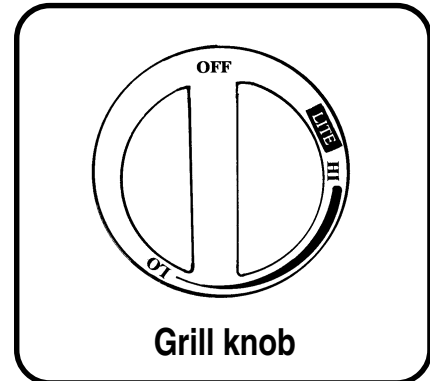

Grill knob

CONTROL KNOB

The burner control has an infinite number of heat settings, and there are no fixed positions on the control knob between HI and LO. To turn the burner on, press the control knob and rotate it counterclockwise to the LITE position.

Adjust the knob to the desired heat setting.

USING THE GRILL

CAUTION:

- Use extreme care when placing the grill components into the grill compartment. Avoid contacting the ceramic igniter which could break preventing operation of the grill.
- The grill must be assembled as shown. The drip tray heat shields must be in place, and the burner must be properly positioned relative to the gas supply. Incorrect assembly of the grill may result in unsafe or hazardous conditions during operation.
- Do not leave the grill unattended while in use.
- Do not use charcoal briquettes or coals of any kind.

After removing all packaging materials, check to be certain that the grill components are correctly assembled in the grill box. The grill grates, stainless steel radiant and the burner are assembled in the grill box from the factory. Follow the steps below to assemble the components in the grill box.

- Disassemble and/or remove the grill grate, stainless steel Radiant and burner from the grill box.
- Install the aluminum rectangular drip pan inside the grill box as shown below.
- Install the heat deflector in the U Section of the burner. Make sure that the heat deflector is sloping toward the rear of the grill box.
- Insert the burner venturi to the orifice located at the front center of the grill box. The holes at the opposite burner ends must be seated on the studs at the rear of the grill box. Then locate the heat deflector between the studs on sides of the the grill can.
- The stainless steel radiant lies on two (2) studs on each end of the grill can.
- Place the grill grate, with raised food containment rail oriented towards the grill box rear.

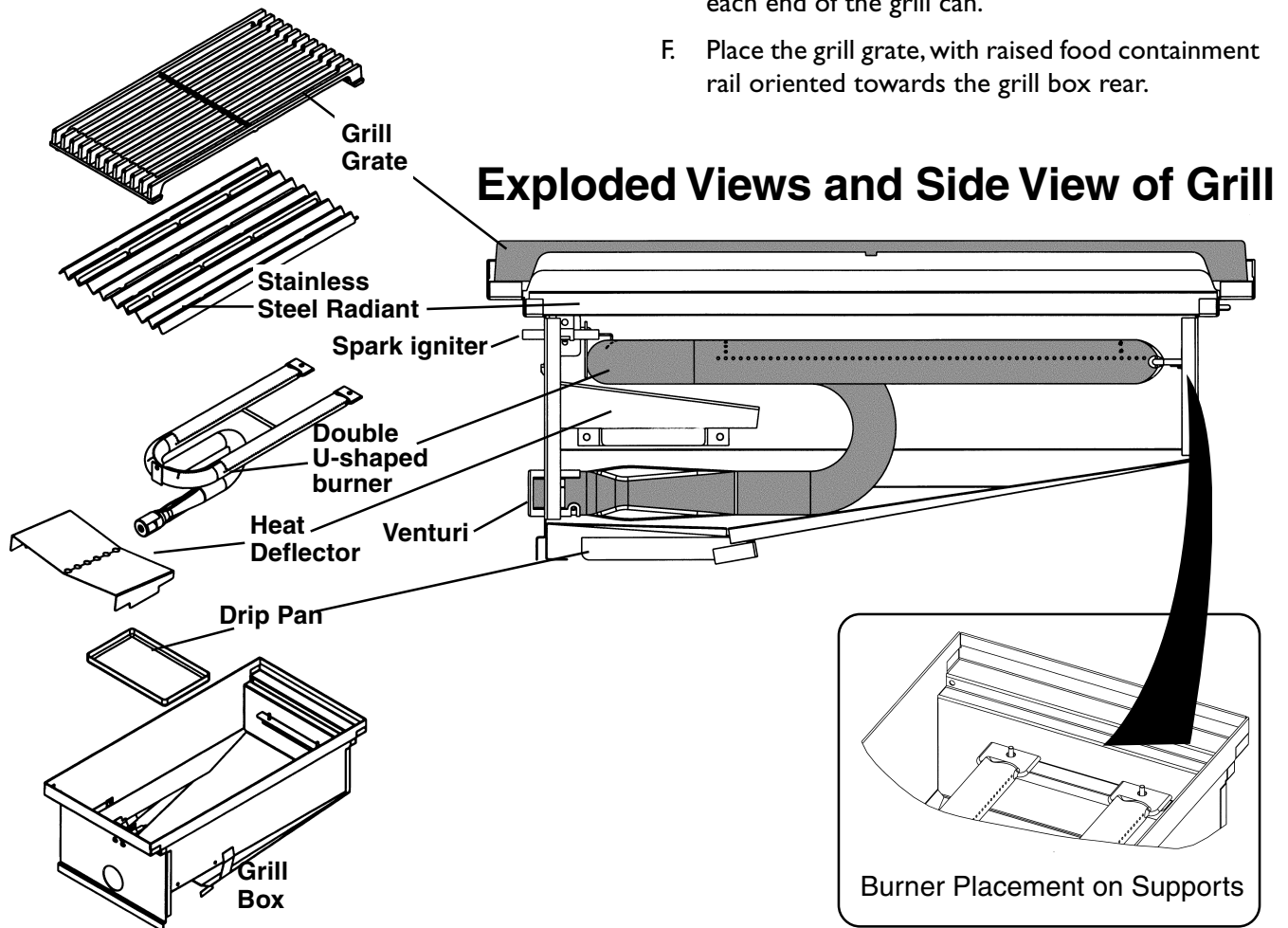

Using the Grill

COOKING ON THE GRILL

- The burner should light within approximately 5 seconds.
- Preheat grill for 15 minutes. The hot grill sears the food, sealing in the juices. The longer the preheat, the faster the meat browns and the darker the brand marks.
- Grilling requires high heat for searing and proper browning. Most foods are cooked at the higher heat settings for most of the cooking time. However, when grilling large pieces of meat or poultry, it may be necessary to turn the heat to a lower setting after the initial browning. This cooks the food through without burning the outside.
- Foods cooked for a long time or basted with a sugary marinade many need a lower heat setting near the end of the cooking time.
- After grilling and the food has been removed, turn the knob to HI and burn off any excess grease which has accumulated on the stainless steel radiant.
- Use a brass wire brush, dipped in hot water, to loosen food particles from the grate.
- When the grill has cooled, clean the drip tray, heat shield and compartment.

GRILLING SUGGESTIONS

- ◆ Trim any excess fat from the meat before cooking. Cut slits in the remaining fat around the edges at 2" (51 mm) intervals.
- ◆ Brush on basting sauce toward the end of cooking.
- ◆ Use a spatula or tongs instead of a fork to turn the meat. A fork punctures the meat and lets the juices run out.
- ◆ Add seasoning or salt after grilling.
- ◆ The grill grate has side and rear rails designed to make it easier to turn with a spatula.
- ◆ After the juices begin to bubble to the surface, turn the meat only once. This helps keep the juices in the meat.
- ◆ Some pieces of meat and poultry cook faster than others. Move those pieces to the cooler area of the grill until the rest have finished.
- ◆ The doneness of meat is affected by the thickness of the cut. Chefs say it is impossible to have a rare doneness with a thin cut.
- ◆ Do not leave the grill unattended while cooking.

HANDLING EXCESSIVE FLARE-UPS

- ◆ The intense heat needed for grilling may also cause flare-ups due to grease dripping on the stainless steel radiant.
- ◆ If flare-ups occur, use a long handled spatula to move the food to another area of the grill.
- ◆ Should flare-ups become excessive, remove the food from the grill and turn off the burner.
- ◆ Excessive flames occur when cooking meat with extra fat, i.e. 30% ground beef, untrimmed steaks, lamb chops, etc.
- ◆ Be cautious when turning meat over.
- ◆ It is important that grilling be supervised at all times.

Grill Cooking Chart

FOOD	WEIGHT OR THICKNESS	CONTROL SETTING	TOTAL SUGGESTED COOKING TIME	SPECIAL INSTRUCTIONS and TIPS	
MEATS					
Beef Hamburgers	1/2 to 3/4 inch	Medium	14 to 18 minutes	Grill, turning once when juices rise to the surface. Do not leave hamburgers unattended since a flare-up could occur quickly.	
		High	12 to 15 minutes		
Steaks Rib, Club, Tenderloin, Porterhouse, T-Bone, Sirloin	1 inch 1-1/2 inches	High	10 to 14 minutes	Remove excess fat from edge. Slash remaining fat at 2-inch intervals. Grill, turning once.	
			13 to 18 minutes		
	1 inch 1-1/2 inches	Medium to High	14 to 22 minutes		
			18 to 27 minutes		
Well-Done (170°F)	1 inch 1-1/2 inches	Medium	22 to 32 minutes		
		Medium	27 to 37 minutes		
Lamb Chops & Steaks	Rare 1 inch (140°F)	High	12 to 15 minutes	Remove excess fat from edge. Slash remaining fat at 2-inch intervals. Grill, turning once.	
		High	14 to 18 minutes		
	Medium (160°F)	1 inch	Medium to High		15 to 20 minutes
		1-1/2 inches	High		18 to 25 minutes
Well-Done (170°F)	1 inch	Medium	20 to 30 minutes		
Pork Chops	1/2 inch	Medium	20 to 40 minutes	Remove excess fat from edge. Slash remaining fat at 2-inch intervals. Grill, turning once. Cook well done.	
	1 inch	Medium	35 to 60 minutes		
Ribs		Medium	45 to 60 minutes	Grill, turning occasionally. During last few minutes brush with barbecue sauce, turn several times.	

Grill Cooking Chart

FOOD	WEIGHT OR THICKNESS	CONTROL SETTING	TOTAL SUGGESTED COOKING TIME	SPECIAL INSTRUCTIONS and TIPS
MEATS				
Pork Ham Steaks (pre-cooked)	1/2 inch	High	4 to 8 minutes	Remove excess fat from edge. Slash remaining fat at 2-inch intervals. Grill, turning once.
Hot Dogs		Medium	5 to 10 minutes	Slit skin. Grill, turning once.
POULTRY				
Chicken Broiler/Fryer Halved or Quartered Breasts	2 to 3 pounds	Low or	1 to 1-1/2 hours	Place skin side up. Grill, turning and brushing frequently with melted butter, margarine, oil or marinade.
		Medium	40 to 60 minutes	
	Medium	30 to 45 minutes		
FISH AND SEAFOOD				
Steaks Halibut, Salmon, Swordfish	3/4 to 1 inch High	Medium to	8 to 15 minutes	Grill, turning once. Brush with melted butter, margarine or oil to keep moist.
Whole Catfish, Rainbow Trout	4 to 8 ounces	Medium to High	12 to 20 minutes	Grill, turning once. Brush with melted butter, margarine or oil

Using the Griddle

THE GRIDDLE

(Available on some models)

The griddle is packaged with a protective grease coating that must be completely removed with a spatula, paper towels, (in crevices use a table knife or toothpick) and cleaned with hot sudsy water. Rinse with vinegar/water and season **now** or it will rust.

TO SEASON OR RE-SEASON YOUR GRIDDLE

Seasoning is an important process which keeps food from sticking during cooking and prevents rusting. Once the griddle is seasoned, it can be used with or without additional grease or shortening.

1. Pour 1 teaspoon of vegetable oil onto the center of the griddle. **Do not use corn oil.** Spread oil over entire surface with a paper towel or coarse cloth.
2. Turn the control knob to a 350° setting. When the oil begins to smoke, turn the control knob OFF. Allow griddle to cool. Wipe off excessive oil with paper towel or cloth.
3. Repeat steps 1 and 2.
4. When the griddle is cool, wipe it clean with a paper towel. Apply a **very thin** layer of vegetable oil. The griddle is now ready to use.

Do not place another utensil on the seasoned griddle to simmer or keep food warm.

USING THE GRIDDLE

1. Check that the drip tray is in place with one side tucked under the griddle overhang.
2. Push down and turn the control knob to a temperature suggested on the Griddle Cooking Chart.
3. Allow 10 to 15 minutes for the griddle to preheat to the temperature selected.
4. Place the food on the griddle and cook to desired doneness.

GRIDDLE COOKING CHART

FOOD	TEMPERATURE
Eggs	225°F to 250°F
Bacon, Ham, Pork Chops	300°F to 325°F
Sausage, Grilled Cheese Sandwiches	325°F to 350°F
Pancakes, French Toast	350°F to 375°F
Hash Brown	400°F to 425°F

GRIDDLE BURNER

The built-in griddle has an aluminum steel tube burner, typical of those used in restaurant griddles. The burner is ignited by an electric glow bar. This device eliminates the need for the continuous burning pilot light. When the glow bar reaches a temperature hot enough

to ignite the gas, a safety valve opens and gas flows to the burner and ignites. The griddle burner is rated at 15,000 BTU HR.

GREASE TRAY

The grease tray is positioned slightly under the front edge of the steel griddle to catch grease or food residue scraped from the surface with a metal spatula.

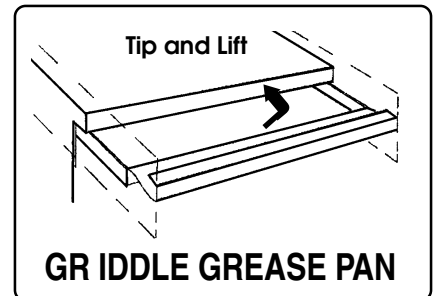

Use care when tipping the tray so that the contents are not spilled when it is removed.

NOTE

1. It is normal for the griddle to darken with use.
2. The Griddle can be used without any additional grease or shortening, after it has been properly seasoned. However, grease or shortening may be used depending on the flavor desired.
3. The griddle must be level or tilted slightly forward for proper operation. Contact your authorized servicer if the griddle needs to be leveled.
4. When used with propane gas, a slight pop or flash may occur at the burner ports a few seconds after the burner has been turned off. This usually occurs after the burner has been on awhile. This is a normal function of your griddle.
5. Remove and clean the grease tray after every use.

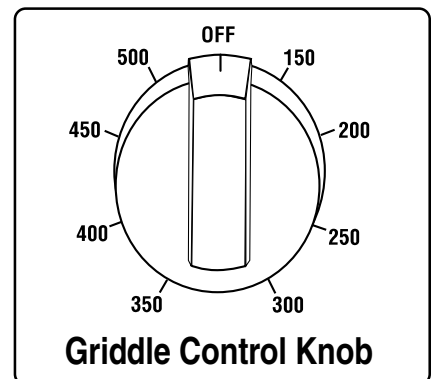

GRIDDLE KNOB

The griddle thermostat has an infinite number of heat settings between 150 and 500°F. There are no fixed positions on the control knob. To turn on the griddle, press then rotate the control knob counter-clockwise to the desired temperature setting. The glow igniter turns on. As soon as it is hot (approximately 60 to 90 seconds), the gas safety valve opens and the burner ignites.

Bake Mode

TIPS FOR BAKE

Preheating The Oven

Many foods such as meat, poultry, casseroles, or other long cooking foods cook well without preheating the oven. See your recipe for preheating recommendation. Preheating is achieved in 10 to 15 minutes, depending on the temperature setting.

Getting the Best Results

- ▲ Minimize opening the door:
 - Use a minute timer.
 - Use the interior oven lights.
- ▲ Choose the right size utensil: use the utensil recommended in the recipe.
- ▲ Store the broiler pans outside the ovens. An extra pan without food, affects the browning and cooking.
- ▲ The type of pan used affects the browning:
 - For tender, golden brown crusts, use light non-stick/anodized or shiny metal utensils.
 - For brown crisp crusts, use dark non-stick/anodized or dark, dull metal utensils or glass bakeware. These may require lowering the bake temperature 25°F.

Oven Heating Light

This light turns on when the oven heats and cycles off when the set temperature has been reached. The cycling continues as long as a **BAKE** or **CONVECTION • BAKE** mode is set.

To Set the All-Gas PRG Oven Models

1. **Set Temperature** on Gas Thermostat Dial.
 - ▲ The bake burner flame lights in 60 to 90 seconds.
 - ▲ The flame cycles off when the selected temperature is reached, then cycles on again to maintain selected temperature.

RACK POSITIONS

One or two racks of food can be cooked in the oven at the same time. Place racks in the oven before turning it on. Position #2 is the most commonly used for single rack cooking. See below for recommended rack positions.

PRG304, PRG36 and PRG48 (large main oven)

- #3 Use this rack in combination with rack #1 for double rack baking.
- #2 Use this rack when baking single pan foods, such as cakes, breads, pies, desserts, casseroles, cookies, or a single rack oven meal.
- #1 Use this rack for air leavened cakes (Angel Food), a large roast, turkey or other large food item.

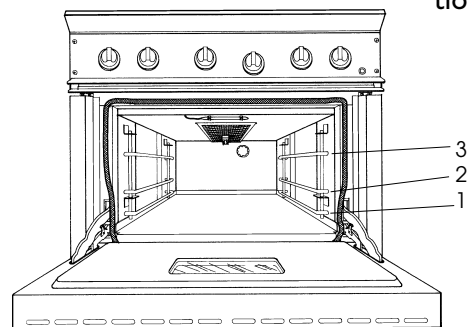

If you are using racks #1 and #3, be sure to **check for doneness sooner than the minimum time**. The food on the lower rack position may cook slightly faster than the food on the upper position. If using one rack with a large commercial baking pan, the food may take a few extra minutes as the air cannot circulate as freely as it does with a smaller pan.

PRG48 (secondary oven)

- #3 Use this rack when broiling.
- #2 Use this rack for baking single food items, such as cake, bread, pie, dessert, casserole, cookies, etc.
- #1 Use this rack for Angel Food cake or a large roast or chicken, etc.

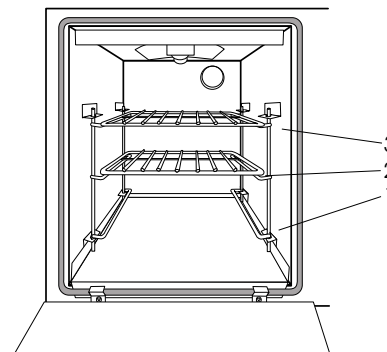

UTENSILS

Type

- ▲ Metal bakeware (with or without a non-stick finish), heat-proof glass, glass-ceramic, pottery, or other utensils suitable for the oven.
- ▲ Suitable cookie sheets have a small lip on one side only.
- ▲ One full commercial baking sheet (18" x 26") in large main oven.
- ▲ 10x13-inch cookie sheet and 7-3/4x2-inch baking sheet in secondary oven

Placement

- ▲ Allow at least 1" of space between the pans and the oven walls so heat can circulate around each pan.
- ▲ Stagger baking utensils so that one is not directly above another. Allow 1-1/2 inches above and below each pan.

Convection • Bake Mode

TIPS FOR CONVECTION•BAKE (Model PRG304, PRG36 and PRG48 - Main Oven Only)

Oven Heating Light

This light turns on when the oven heats and cycles off when the set temperature has been reached. The cycling continues as long as a BAKE or CONVECTION•BAKE mode is set.

Preheating The Oven

When roasting and baking foods with convection longer than 15 minutes, preheating is not necessary.

TIPS IN CONVECTION MODE

- Lower oven temperature 25° to 50°F. when converting regular BAKE to CONVECTION • BAKE settings for baked food items such as breads, cakes, cookies and muffins, etc.
- Length of cooking time may be shorter than the standard bake time.
- The pan shape, dimensions and various combinations of pans may affect cooking times and browning.
- Place a single crust pumpkin pie directly on a small aluminum cookie sheet for optimum baking.

HIGH ALTITUDE BAKING

When baking at high altitudes, in either BAKE or CONVECTION • BAKE, recipes and baking times vary. For accurate information, write the Extension Service, Colorado State University, Fort Collins, Colorado 80521. There may be a cost for the bulletins. Specify the type of information you want (example: cakes, cookies, breads, etc.).

RACK POSITIONS

One, two or three racks of food can be cooked in the oven at the same time. Place racks in the oven before turning it on. See previous page for positioning racks.

- #3 Use this rack in combination with rack #1 for double rack baking.
- #2 Use this rack when baking single pan foods such as sheet cakes, some breads, pies, desserts, casseroles, cookies, or a single rack oven meal. Use with racks #1 and #3 for three sheets of cookies.
- #1 Use this rack for air leavened cakes (Angel Food), frozen pie, large roast or turkey. Use in combination with rack #3 for a 2 rack oven meal or more than 2 cakes.

If you have loaded the oven, be sure to check the items for doneness sooner than the minimum time.

UTENSILS

Type

- ▲ Aluminum bakeware gives the best browning results.
- ▲ Cookie sheets should have low sides; use aluminum commercial half-sheets or professional cooking utensils.
- ▲ Light or dark pan finish affects timing: Light pan finish gives a medium to golden brown appearance; dark pan finish gives a darker brown.
- ▲ The broil pan and grid can be used for roasting tender meats and poultry as an alternate utensil to a roasting rack and low sided pan.

Placement

- ▲ For better browning, utensils such as cookie sheets, jelly roll pans and rectangular baking pans should be placed crosswise on the rack with the shorter sides on the right and the left. This allows the air to circulate freely.
- ▲ When baking on more than one rack, pans do not need to be staggered.

CONDENSATION

It is normal for a certain amount of moisture to evaporate from the food during any cooking process. The amount depends on the moisture content of the food. The moisture will condense on any surface cooler than the inside of the oven, such as the control panel.



CAUTION:

WHEN USING THE OVEN IN ANY MODE

Never use aluminum foil to cover the oven racks or to line the oven. It can damage the oven liner if heat is trapped under it.

Other Uses of Bake

SLOW COOKING AND LOW TEMPERATURE USES OF THE OVEN

In addition to providing perfect temperatures for baking and roasting, the oven can be used at low oven temperatures to keep hot, cooked foods at serving temperature, to cook foods long and slow (as if using a crock pot), to dehydrate food, to warm plates, and to defrost foods.

Hot cooked foods can be kept at serving temperatures. Set the oven to bake and use the temperature suggested on the chart.

Foods needing to be kept moist must be covered with a lid or aluminum foil.

Slow Cooking of one food or an oven meal is possible by setting the oven to bake and the thermostat to 225°F.

Uncooked frozen foods can be thawed with the oven selector set to bake and the thermostat to 150°F. Keep food tightly wrapped in foil and thaw just enough to handle. Cook immediately. Do not re-freeze.

Frozen cooked foods can be thawed with the oven selector set to bake and the Thermostat set to 170°F. Loosen the freezer paper wrapping. Do not use plastic.

FOOD SAFETY

The United States Department of Agriculture says:
DO NOT hold foods at temperatures between 40°F to 140°F more than 2 hours.

SUGGESTED TEMPERATURE CHART TO KEEP FOOD HOT

Food	Oven Temperature °F
Beef	
Rare	140° – 155°F
Medium	155° – 170°F
Well done	170° – 180°F
Bacon	200° – 225°F
Biscuits and Muffins (covered)	170° – 185°F
Casserole (covered)	170° – 200°F
Fish and Seafood	170° – 200°F
French Fried Foods	200° – 225°F
Gravy or Cream Sauces (covered)	170° – 180°F
Lamb and Veal Roasts	170° – 200°F
Pancakes and Waffles (covered)	200° – 225°F
Potatoes	
Baked	200°F
Mashed (covered)	170° – 185°F
Pies and Pastries	170°F
Pizza (covered)	225°F
Pork	170° – 200°F
Poultry (covered)	170° – 200°F
Vegetables (covered)	170° – 175°F

OVEN CONTROL KNOB and HEATING LIGHT

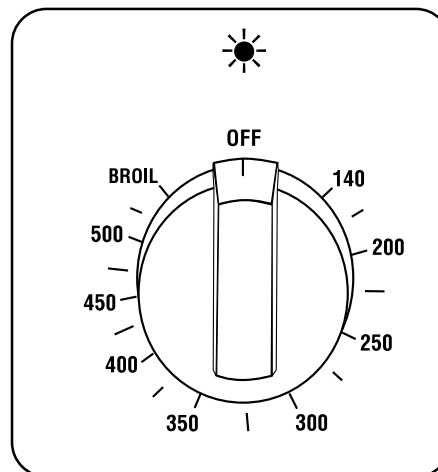

Setting Broil Mode

BROIL IN THE LARGE MAIN OVEN and PRG48 SECONDARY OVEN

TIPS FOR BROIL

PRE-HEATING THE INFRA-RED BROILER (Large main oven)

It is recommended that you do not pre-heat the broil burner before starting to cook. Only very fast cooking foods, such as thin fillets of fish, would require preheating so the surface of the food could brown in the time the food was cooked. If pre-heating is necessary, pre-heat no more than 2 to 3 minutes.

PRE-HEATING THE BROIL BURNER PRG48 (secondary oven)

It is recommended that the broil burner be pre-heated 5 minutes before broiling, when food items are 3/4" to 1" thick. Items less than 3/4", such as a fish fillet, need 10 minutes preheat. Do not preheat for chicken pieces.

GETTING THE BEST RESULTS

- ▲ Be sure to defrost food before broiling.
- ▲ Broil with the door closed in PRG All-Gas ovens.
- ▲ Steaks should be at least 1" thick if rare meat is desired.
- ▲ Turn foods over only once, after half the total cooking time. It is not necessary to turn very thin foods (ham slices, fillets of fish, etc.). Liver slices must be turned over regardless of thickness.
- ▲ Use a Minute timer. Set it for the minimum time to check the food.

RACK POSITIONS

Before turning on the oven, place the rack in the desired position. The PRG ranges have a special rack in the large main oven for broiling. Turn this rack over, so that the broil pan fits into the area outlined.

PRG Broil Pan Rack Template



- #3 Use this rack position when broiling beef steaks, ground meat patties, ham steak and lamb chops 1 inch or less in thickness. Also, use when top browning foods.
- #2 Use this rack position when broiling meat 1-1/8 inches or more in thickness, fish, poultry, pork chops, ham steaks 1 inch or more in thickness and when broiling chicken halves.

UTENSILS

- ▲ The PRG48 has two broil pans, all other ranges have one. The aluminum broil pan is to be used in the secondary oven. Use the chrome and porcelain enamel two-piece broil pan and grid in large main oven. DO NOT cover the slotted grid (top) with aluminum foil.
- ▲ Use metal or glass-ceramic bakeware when top browning casseroles, main dishes, or bread.
- ▲ DO NOT use heat-proof glass or pottery. This type of glassware cannot withstand the intense heat of the infra-red broiler

BROILING WITH A REGULAR MEAT THERMOMETER

For accurately determining the degree of doneness for a thick steak or chop (at least 1-1/2 inches thick), use a regular meat thermometer. Insert the point of the thermometer into the side of the meat to the center of the steak or chop.

For rare steaks, cook the first side to 90°F. For medium or well done steaks, cook the first side to 100°F. Turn and cook the second side to desired internal temperature.

NOTE:

It is impossible to use the oven and the broiler simultaneously in the same oven. When one is on the other one cannot be turned on.

Setting Broil Mode

BROIL

In all the large main ovens only the gas infra-red broiler heats in the BROIL mode. In the PRG48 secondary oven only the broil burner heats in the BROIL mode.

NOTE: Successful broiling requires constant exposure to high, intense heat (infra-red heat from the gas broiler).

Place rack in position recommended on Page 27. For most foods that require use of a non-preheated broiler, set food on two piece broil pan and place in oven. For very fast cooking foods in which the broiler may be preheated for no more than 2 or 3 minutes, place food and broil pan in oven after preheating is complete.

To Set the Oven to Broil

1. **Set Thermostat to BROIL setting.**
 - ▲ The Infrared broiler flame lights in 60 to 90 seconds.
2. **KEEP DOOR CLOSED throughout broil cycle.**
 - ▲ Your Professional® Range comes with a large two-piece broil pan. The slotted grid allows drippings to flow into the lower pan, away from the intense heat of the broil element, minimizing spattering and smoking. This pan is designed for use in the large main oven.

Oven Heating Light

This light turns on when the oven heats and cycles off when the set temperature has been reached. The cycling continues as long as a BROIL mode is set.

NOTE: In gas ovens, the intense heat emitted by the infra-red broiler makes it necessary to keep the door closed.

HEATING LIGHT AND OVEN CONTROL KNOBS

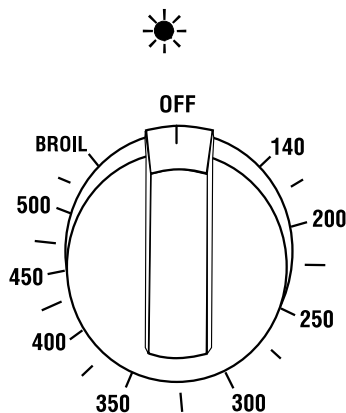

CAUTION

Be careful not to damage the screen covering the infra-red broiler of gas ovens. If the screen is damaged, air can enter the distribution box behind the screen, possibly resulting in an explosion. Do not apply cleaners or wipe screen.

GAS OVEN INFRA-RED BROILER

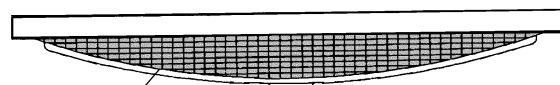

Screen should be glowing red

Flame should be approximately 1/8" thick and blue

Oven broiler flame should be visually inspected to resemble diagram.

Care and Maintenance

Before cleaning the range, be certain that the burners and oven(s) are turned off and the grates and exterior surfaces are cool. Clean Griddle and Grill carefully while still warm. Always clean the range with caution. A wet sponge or cloth used to wipe spills off a hot area can result in steam burns.

BURNER GRATES

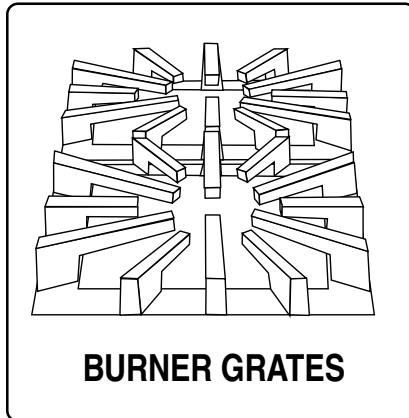

Two grates interlock, from front to back, to form a continuous surface. The burner grates are porcelain enamel over cast iron for durability. They may be wiped while on the cooktop with hot, soapy water, rinsed and wiped dry.

Due to the extreme temperatures and rapid temperature change that the grates are exposed to, in addition to spillage of acidic and sugar-laden foods onto the grates, some deterioration of the porcelain enamel surface is normal and expected over time. Deterioration may include discoloration and, in extreme cases, crazing (fine, hair-like cracks) and/or chipping of the porcelain. The extent of deterioration will be directly related to the severity and amount of usage.

If cleaning necessitates removal of grates, **care should be taken in lifting them; they are very heavy.** Be sure to place the grate on a protected surface.

SEALED BURNERS

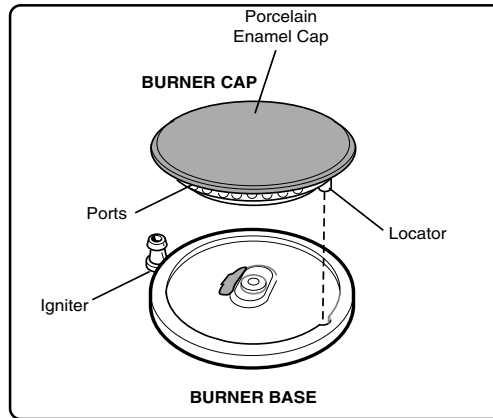

For proper lighting and performance of the burners, keep the igniters, burner caps, and ports clean and free of soil. It is necessary to clean these only when the flame does not burn blue completely around and within the burner, when there is a severe boil over, when the burner does not light, or when the electronic igniter clicks continuously even after the flame has been lit. See Cleaning Chart, Page 31.

When the burner and burner grate are cool, remove the grate. Grasp the burner cap and remove it. Refer to drawing above.

Clean the burner cap with a cleanser suitable for enamel. Use a wire, a straightened paper clip or needle to clear the ports. Do not use a toothpick; it could break off in the port. If necessary, wash, rinse and dry burner according to the Cleaning Chart. Be sure to dry the burner base and cap thoroughly before reinstalling the burner cap.

Replace the burner cap, being sure to properly line up the locator tab with the notch in the burner base. Thoroughly dry the igniters to prevent nuisance or continuous sparking.

The trim strips are anodized aluminum; avoid cleaning products that contain ammonia. See Cleaning Chart, Page 32.

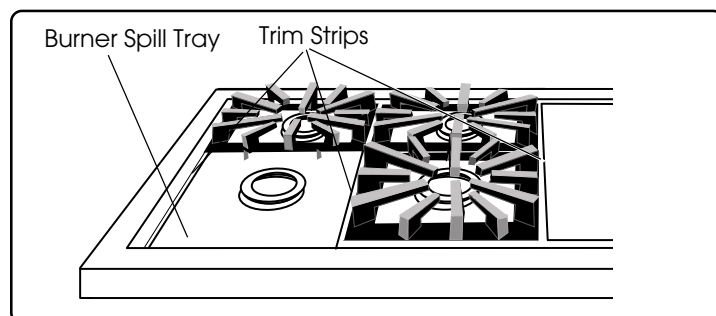

CARE AND MAINTENANCE

GRILL GRATE

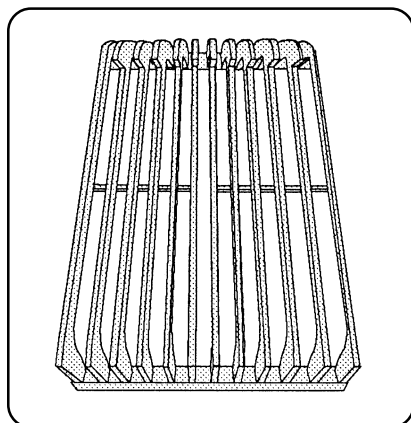

The easiest way to clean the grill is while it is warm (not hot) after cooking is completed and after turning off the flame. Wear a barbecue mitt to protect your hand from the heat and steam. Use a brass grill brush and water on the grill grate in most instances. For stubborn stains, use a soap filled steel wool pad. Steam created as the water contacts the hot grill grate assists the cleaning process by softening any food particles, which will fall off and burn. If the grill is allowed to cool before cleaning, it will be more difficult.

OTHER GRILL PARTS

After the grill has cooled, remove the **grate, stainless steel radiant and double U-shaped burner, heat deflector, removable heat shield, and drip pan.**

Lift the **double U-shaped burner** where it hooks to the brackets at the rear of the box. (See Figure on Page 19.) Pull burner from the burner hole to remove it from the gas connection. The burner may be cleaned, if desired, with a wire brush. All gas ports must be free of blockage for safe operation. Use a metal paper clip to remove debris from port holes.

Lift out and wash the stainless steel **removable heat shield**, and **grease drip pan**. Use hot sudsy water, rinse and dry.

Tape newspaper to cover the 2 black side trim rails next to the grill on the porcelain maintop and all griddle parts. Oven cleaner will permanently damage these parts so they need to be covered. Spray cleaner using short, controlled applications to stainless surfaces only. Don't spray directly inside hole for burner connection or onto the spark igniter. Wait 30 minutes to 1 hour. Wear rubber gloves and wipe off cleaner; rinse and dry. Apply again if necessary.

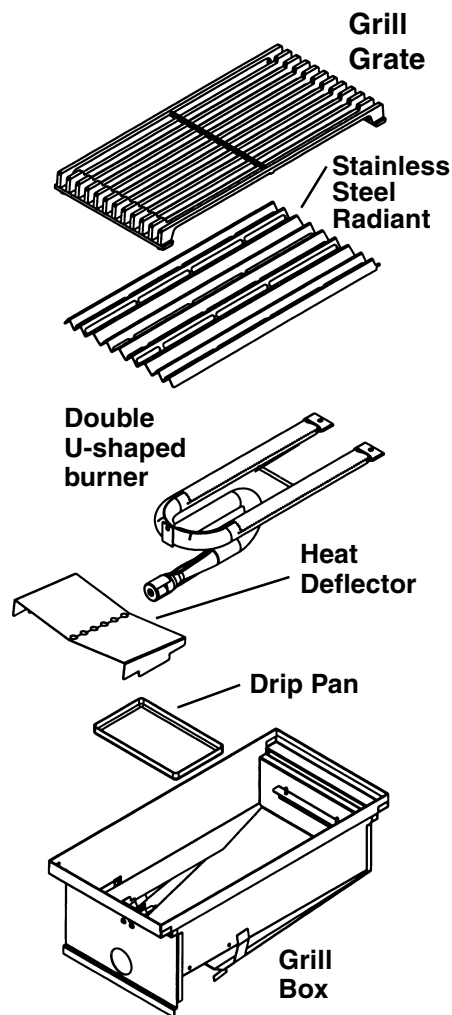

GRILL CAUTIONS:

1. Do not clean any part of the grill in any self-cleaning oven.
2. When disassembling or reassembling the grill, use extreme caution to avoid contact with the spark igniter. The igniter could break, preventing operation of the grill.
3. Use caution when cleaning around sharp metal corners and edges. Use of cleaning gloves is recommended.

Range Cleaning Chart

When cleaning this range:

Avoid cleaning any part of the range while hot.

1. Use the mildest cleaning procedure that will do the job efficiently and effectively. Some cleaners of the same type are harsher than others. Try on a small area first.
2. Always rub metal finishes in the direction of the polish lines for maximum effectiveness and to avoid marring the surface.
3. Use only clean soft cloths, sponges, paper towels, fibrous brushes, plastic, non-metal or steel wool soap pads for cleaning and scouring, as recommended on the chart.
4. Any part of this appliance, except the steel griddle, can be cleaned with hot sudsy water. When rinsing is required, rinse thoroughly.
5. Always wipe dry immediately to avoid water marks.

Brand Names

The use of brand names is intended only to indicate a type of cleaner. This does not constitute an endorsement. The omission of any brand name cleaner does not imply its adequacy or inadequacy. Many products are regional in distribution and can be found in the local markets.

It is imperative that all products be used in strict accordance with instructions on the package.

The following chart gives directions for cleaning this range:

Part/Material/ Soil Condition	Cleaning Products/Directions
<p style="text-align: center;">COOKTOP</p> <p>Burner Caps</p>	<p>Wire, straightened paper clip or needle. Do not use a toothpick. Hot sudsy water.</p> <p>Powdered cleanser: Bon-Ami®, Ajax®, Comet®.</p> <ul style="list-style-type: none"> • Clear ports of any soil. Wash, rinse and dry. Make certain that all burners, including the two far left ExtraLow® burners, are turned OFF before cleaning.
<p>Control Knobs, Plastic</p>	<p>Hot sudsy water.</p> <ul style="list-style-type: none"> • Pull knobs straight forward. Wash, do not soak. Rinse, dry and replace. Make certain the knobs are reinstalled in the proper location. Do not force knobs onto wrong control.
<p>Back Panel Frame Stainless Steel</p>	<p>Hot sudsy water.</p> <ul style="list-style-type: none"> • Wash, rinse thoroughly, and dry. <p>General Kitchen Cleaners: Formula 409®, Fantastik®.</p> <ul style="list-style-type: none"> • Spray cleaner on cloth, then wipe surface. <p>Stainless steel cleaners: Stainless Steel Magic®, Revere Ware® Instant Copper and Stainless Steel Cleaner, Bon-Ami.</p> <ul style="list-style-type: none"> • Use the mildest cleaning procedure first. Apply cleaner with a damp sponge, rinse thoroughly, and dry. Always scrub in the direction of the grain. Do not use a steel wool pad or steel brush, as it will scratch the surface. Avoid applying too much pressure when scrubbing. <p>DO NOT allow deposits to remain for long periods of time. DO NOT allow salt solutions, disinfectants, bleaches or cleaning compounds to remain in contact with stainless steel for extended periods. Many of these compounds contain chemicals which could prove harmful. Rinse with water after exposure and wipe dry with a clean cloth.</p> <p style="text-align: right;">Continued → →</p>

Range Cleaning Chart

Part/Material/Soil Condition	Cleaning Products/Directions
<p>Grates Porcelain Enamel on Cast Iron</p>	<p>Hot sudsy water. Mild Abrasive Cleansers: Bon-ami®, Soft Scrub®. For stubborn stains: a soap filled steel wool pad.</p> <ul style="list-style-type: none"> Wash, rinse and dry. The occasional use of mild abrasive cleaners or steel wool soap filled pad is okay. Abrasive cleansers, used vigorously or too often, can eventually harm the enamel. Apply with a damp sponge, rinse thoroughly, and dry. When removing the grates, care should be taken in lifting them. Be sure to place the grate on a protected surface. <p>NOTE: Grates will develop blisters and chips in the porcelain with use due to the extreme operating temperatures</p>
<p>Griddle – Steel</p>	<p>See Pages 23 and 34 for detailed directions.</p>
<p>Griddle Grease Pan – Stainless Steel</p>	<p>See Cooktop Back Panel Stainless Steel Directions on Page 37.</p>
<p>Grill Grate Porcelain Enamel on Cast Iron</p>	<p>See Page 34 for detailed directions.</p>
<p>Grill Box, Heat Shields, Radiant Stainless Steel</p>	<p>The quality of this material resists most stains and pitting, providing the surface is kept clean and protected.</p> <p>Nonabrasive Cleaners: Hot soapy water, ammonia or detergent and water.</p> <ul style="list-style-type: none"> Apply with sponge or cloth then wipe clean using a clean cloth and thoroughly dry the surface. Regularly apply stainless steel cleaner-polish such as Stainless Steel Magic® to protect the finish and leave a soft lustre. Do not allow food deposits to remain on stainless steel for any length of time. <p>Mild Cleaners: General kitchen cleaners such as Fantastik®, Formula 409®, Vinegar: to remove hard water spots</p> <ul style="list-style-type: none"> Apply with sponge or cloth, then wipe clean using a clean cloth and thoroughly dry the surface. <p>Mild Abrasive Cleaners: RevereWare Instant Stainless Steel Cleaner®, Kleen King Stainless Steel Cleaner or Liquid.</p> <ul style="list-style-type: none"> Apply with a damp sponge or cloth. Rub lightly in direction of the polish lines. Wipe clean using damp cloth or sponge and dry surface. Remember, chlorine or chlorine compounds (check the labels) are corrosive to stainless steel. It is very important to rinse thoroughly and dry if a cleaning agent with chlorine is used. <p>Heat tint or discoloration: RevereWare Instant Stainless Steel Cleaner®.</p> <ul style="list-style-type: none"> Apply with a damp cloth or sponge. Satisfactory for use on all finishes if rubbing is light. Use in direction of grain lines.
<p>Grill Drip Pan Aluminum</p>	<p>Hot sudsy water, rinse and dry thoroughly. For stubborn stains use a soap filled steel wool pad.</p>

Range Cleaning Chart

Part/Material/ Soil Condition	Cleaning Products/Directions
<p style="text-align: center;">OVEN</p> <p>Broil Pan Grid Chrome Plated</p>	<p>To loosen cooked on food, sprinkle empty hot grid with powdered laundry detergent or squirt with liquid detergent and cover with wet paper towels. Allow to stand.</p> <p>Hot sudsy water.</p> <ul style="list-style-type: none"> Wash, rinse thoroughly, and dry. <p>Cleaners: Soft Scrub®.</p> <ul style="list-style-type: none"> Apply with a damp sponge or cloth according to manufacturer's directions. Rinse and wipe dry. <p>Powdered Cleanser: Bon-Ami®, Comet®, Ajax®.</p> <ul style="list-style-type: none"> Apply with a damp sponge or cloth according to manufacturer's directions. Rub lightly, it may scratch the finish. Rinse thoroughly and wipe dry. <p>Soap-filled fiber or steel wool pads: S.O.S®, Brillo®.</p> <ul style="list-style-type: none"> Dampen pad, rub lightly, it may scratch the finish. Rinse thoroughly and wipe dry.
<p>Broil Pan Bottom Porcelain Enamel</p>	<p>See instructions for Cavity, Models PRG304, PRG36 and PRG48) below.</p>
<p>Infra Red Broiler</p>	<p>DO NOT APPLY CLEANERS OR WIPE THE SCREEN.</p>
<p>Cavity Porcelain Enamel on Steel</p>	<p>Porcelain enamel is acid resistant, but not acid proof. Acid foods such as citric juices, tomatoes, rhubarb, vinegar, alcohol or milk, should be wiped up and not allowed to bake onto the porcelain during the next use. Over a period of time, the porcelain may craze (get fine hairlike lines).</p> <p>Hot sudsy water.</p> <ul style="list-style-type: none"> Wash, rinse thoroughly, and dry. <p>Mild Cleaners: Bon-Ami, ammonia, or ammonia and water, Soft Scrub.</p> <ul style="list-style-type: none"> Apply to a damp sponge or cloth. Rub lightly. Rinse thoroughly. Dry. <p>If food has burned onto the oven and is difficult to remove, the spots can be soaked with a cloth saturated with household ammonia. Close the door and allow it to soak for an hour or two, or until the food soil can be easily removed with a damp soapy cloth or mild abrasive. A solution of about 3 tablespoons of household ammonia in a half cup of water may be placed in the warm oven overnight. This will loosen hardened residue and spillage so that it may be easily wiped up. The ammonia solution may be added to warm water for a thorough wiping of the oven.</p> <p>Soap filled fiber or steel wool pads: S.O.S, Brillo.</p> <ul style="list-style-type: none"> For stubborn stains, the occasional use of abrasive cleaners is okay, but, if used vigorously or too often, they can eventually harm the enamel. Dampen pad, rub surface lightly, rinse thoroughly, and dry. <p>Harsh Cleaners: Easy Off® Oven Cleaner, Dow® Oven Cleaner.</p> <p>NOTE: Commercial oven cleaners are corrosive to infra-red broiler and thermostat bulbs. DO NOT spray or wipe cleaners onto these parts. If some cleaner gets on the broiler or thermostat bulb, wipe it off immediately with a clean damp cloth.</p> <ul style="list-style-type: none"> Follow manufacturer's instructions. Rinse thoroughly and wipe dry. <p style="text-align: center;">Continued ➡ ➡</p>

Range Cleaning Chart

Part/Material/Soil Condition	Cleaning Products/Directions
Front Frame Stainless Steel	See Cooktop , Back Panel, Page 31.
Racks Chrome Plated	<p>Hot sudsy water.</p> <ul style="list-style-type: none"> Wash, rinse thoroughly, and dry. <p>Cleaners: Soft Scrub®.</p> <ul style="list-style-type: none"> Apply with a damp sponge or cloth according to manufacturer's directions. Rinse and wipe dry. <p>Powdered Cleanser: Bon-Ami®, Comet®, Ajax®.</p> <ul style="list-style-type: none"> Apply with a damp sponge or cloth according to manufacturer's directions. Rub lightly. Rinse thoroughly and wipe dry. <p>Soap filled fiber or steel wool pads: PanHandl'rs, S.O.S®, Brillo®.</p> <ul style="list-style-type: none"> Dampen pad, rinse thoroughly, and dry. <p>Harsh Cleaners: Easy Off® Oven Cleaner, Dow® Oven Cleaner.</p> <p>NOTE: Some commercial oven cleaners cause darkening and discoloration. Test the cleaner on a small part of the rack and check for discoloration before cleaning the entire rack.</p> <ul style="list-style-type: none"> Apply a generous coating. Allow to stand for 10 to 15 minutes. Rinse thoroughly and wipe dry. <p>If the racks do not slide easily after being cleaned, dampen a paper towel with a small amount of cooking oil and rub it lightly over the side rails.</p>
DOOR Exterior, Frame, Handle, Heat Deflector Stainless Steel	<p>Use care to keep cleaners and water away from the door vents. If water or cleaners spill into the vents, water may streak the glass inside.</p> <p>See Cooktop, Back Panel, Stainless Steel, Page 31.</p>
Interior Porcelain Enamel	See Oven Cavity , Page 33.
Seal Door Gasket.	<p>General Kitchen Cleaners: Formula 409®, Fantastik®.</p> <ul style="list-style-type: none"> Spray on and blot dry with a cloth. Do not rub. Do not move, remove or damage mesh

Do-It-Yourself Maintenance

OVEN LIGHT BULB REPLACEMENT

Replace only with a 40 watt, 120 volt appliance light bulb. **DO NOT USE** a standard household light bulb in any oven.

To Replace the Light Bulb:

1. Turn oven light switch to the off position. Let bulb and cover cool completely.
2. Remove the light cover. Turn the cover to the left (counterclockwise) to unscrew it.
3. Remove the burnt out bulb. **Replace it with a 40 watt, appliance light bulb only.**
4. Replace cover. Turn circuit back on, if need be. (See Caution.)

POWER FAILURE

In the event of a power failure, only the standard burners can be lighted manually. It is necessary to light each standard burner individually.

If the cooktop is being used when the power failure occurs, turn all of the burner control knobs to the **OFF** position. Then, the standard burners can be lighted by holding a match at the ports and turning the control knob to the **HI** position. Wait until the flame is burning all the way around the burner cap before adjusting the flame to the desired height.



CAUTION:

Before replacing the light bulb, be certain the **Oven Light Switch** is in the **off** position. Let bulb and cover cool completely before touching. **If the light bulb glass comes loose from the base, turn the power to the oven OFF at the circuit breaker panel, before attempting to remove the bulb base from the socket.**

The two ExtraLow® burners on the far left side, cannot be used during a power failure. Be sure to turn them **OFF** if a power failure occurs, as they will not turn back on until both control knobs are turned **OFF** and then turned back on again. See “What to do if you Smell Gas”, inside front cover.

For All-Gas Ranges, the oven and broiler burners can not be turned on during a power failure.

Before Calling for Service

Before calling for Service, check the following to avoid unnecessary service charges.

Be sure to check these items first:

Is there a power outage in the area?

Is the household fuse blown or the circuit breaker tripped?

Is the range disconnected from the electrical supply?

IF THE BURNERS DO NOT IGNITE

- Are the burner caps properly aligned and seated in the burner base?
- Are the burner ports clogged?
- Is a fuse blown or is the circuit breaker tripped?
- Is the manual shut-off valve closed, preventing the flow of gas?

DATA RATING PLATE

The data rating plate shows the model and serial numbers of your range. It is located behind the toe kick at the bottom of the range. To access the rating plate, remove the two toe kick attachment screws, then carefully remove the toe kick panel.

For PRG All-Gas models, the data rating plate is found in the U-shaped channel at the bottom front of the range.

SERVICE INFORMATION

For handy reference, copy the information below from the data rating plate. Keep your invoice for Warranty validation.

Model Number

Serial Number

Date of Purchase

Dealer's Name

Dealer's Phone Number

Service Center's Name

Service Center's Phone Number

Also, enter this information on the Product Registration Form included with this product, then mail it to the indicated address to receive your free Thermador Professional® Cookbook.



CAUTION:

BEFORE REMOVING THE TOE KICK PANEL, DISCONNECT THE RANGE FROM THE ELECTRICAL POWER SUPPLY. REINSTALL THE TOE KICK PANEL BEFORE RECONNECTING THE RANGE TO THE POWER SUPPLY AND OPERATING THE RANGE.

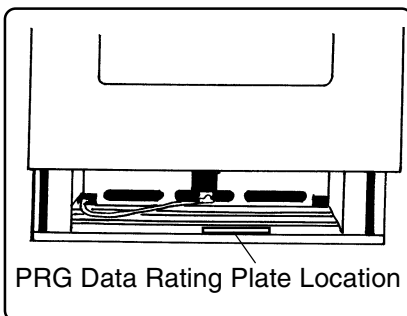

PRG Data Rating Plate Location

Warranty

Full One Year Warranty

Covers one year from the date of installation or date of occupancy for a new previously unoccupied dwelling, Save your dated receipt or other evidence of the installation/occupancy date.

Thermador® Will Pay For:

All repair labor and replacement parts found to be defective due to materials and workmanship. Service must be provided by a Factory Authorized Service Agency during normal working hours. For a Service Agency nearest you, please call 800/735-4328.

Thermador Will Not Pay For:

1. Service by an unauthorized agency. Damage or repairs due to service by an unauthorized agency or use of unauthorized parts.
2. Service visits to:
 - Teach you how to use the appliance.
 - Correct the installation. You are responsible for providing electrical wiring and other connecting facilities.
 - Reset circuit breakers or replace home fuses.
3. Damage caused from accident, alteration, misuse, abuse, improper installation or installation not in accordance with local electrical codes or plumbing codes, or improper storage of the appliance.
4. Repairs due to other than normal home use.
5. Service labor during limited warranty period.
6. Travel fees and associated charges incurred when the product is installed in a location with limited or restricted access, (i.e., airplane flights, ferry charges, isolated geographic regions).

Warranty applies to appliances used in residential application; it does not cover their use in commercial installations.

This warranty is for products purchased and retained in the 50 states of the U.S.A., the District of Columbia and Canada. Should the appliance be sold by the original purchaser during the warranty period, the new owner continues to be protected until the expiration date of the original purchaser's warranty period.

The warranty applies even if you should move. **THERMADOR DOES NOT ASSUME ANY RESPONSIBILITY FOR INCIDENTAL OR CONSEQUENTIAL DAMAGES.** Some states do not allow the exclusion or limitation of incidental or consequential damages, so the above limitation or exclusion may not apply to you. This warranty gives you specific legal rights and you may also have other rights which may vary from state to state or province to province.

Specifications are for planning purposes only. Refer to installation instructions and consult your countertop supplier prior to making counter opening. Consult with a heating and ventilating engineer for your specific ventilation requirements. For the most detailed information, refer to installation instructions accompanying product or write Thermador indicating model number.

We reserve the right to change specifications or design without notice. Some models are certified for use in Canada. Thermador is not responsible for products which are transported from the United States for use in Canada. Check with your local Canadian distributor or dealer.

For the most up to date critical installation dimensions by fax, use your fax handset and call 702/833-3600. Use code #8030.



Thermador[®]

5551 McFadden Avenue, Huntington Beach, CA 92649 • 800/735-4328
ECO 5203-1 • 15-13-095A • © BSH Home Appliances Corp. 1998 • Litho in U.S.A., 3/01

Free Manuals Download Website

<http://myh66.com>

<http://usermanuals.us>

<http://www.somanuals.com>

<http://www.4manuals.cc>

<http://www.manual-lib.com>

<http://www.404manual.com>

<http://www.luxmanual.com>

<http://aubethermostatmanual.com>

Golf course search by state

<http://golfingnear.com>

Email search by domain

<http://emailbydomain.com>

Auto manuals search

<http://auto.somanuals.com>

TV manuals search

<http://tv.somanuals.com>