

# INSTRUCTION MANUAL

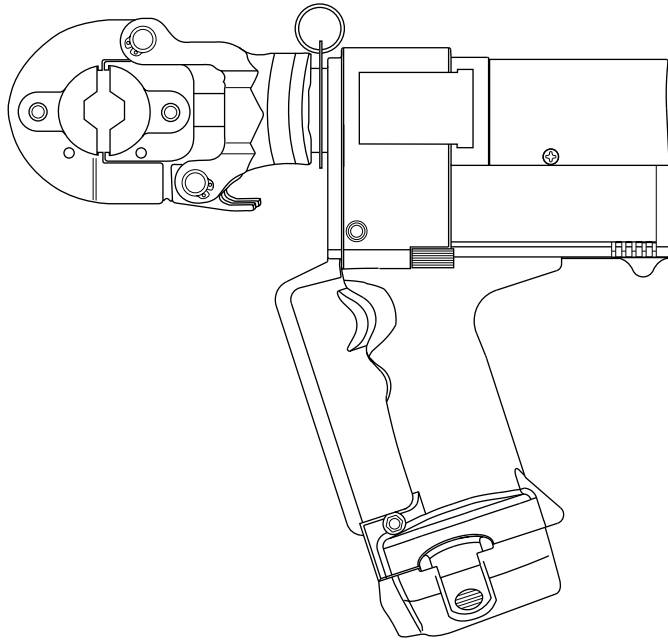

## **GATOR<sup>®</sup> EK22GL** **Battery-powered,** **High-speed Crimping Tool**



**Read and understand** all of the instructions and safety information in this manual before operating or servicing this tool.

## Table of Contents

Description .....	2
Safety .....	2
Purpose of this Manual .....	2
Important Safety Information .....	3–4
Identification .....	5
Specifications .....	5
Operation .....	6–7
Dies and Connectors .....	8
Maintenance .....	9
Troubleshooting .....	10
Disassembly .....	11
Assembly .....	12
Illustrations .....	13–15
Parts List .....	16–18

## Description

The EK22GL Battery-powered, High-speed Crimping Tool is a hand-held, self-contained crimping tool intended to crimp copper cable with K22-type and W-type dies.

## Safety

Safety is essential in the use and maintenance of Greenlee tools and equipment. This manual and any markings on the tool provide information for avoiding hazards and unsafe practices related to the use of this tool. Observe all of the safety information provided.

## Purpose of this Manual

This manual is intended to familiarize all personnel with the safe operation and maintenance procedures for the following Greenlee tool:

EK22GL Battery-powered, High-speed Crimping Tool

Keep this manual available to all personnel.

Replacement manuals are available upon request at no charge.

All specifications are nominal and may change as design improvements occur. Greenlee Textron shall not be liable for damages resulting from misapplication or misuse of its products.

GATOR is a registered trademark of Greenlee Textron.

AVIA is a registered trademark of Avia International.

Blackburn is a registered trademark of Thomas & Betts.

Mobil is a registered trademark of Mobil Oil Corporation.

NUTO is a registered trademark of Exxon Corporation.

Tellus is a registered trademark of Shell Oil Company.

**KEEP THIS MANUAL**

## IMPORTANT SAFETY INFORMATION



### SAFETY ALERT SYMBOL

This symbol is used to call your attention to hazards or unsafe practices which could result in an injury or property damage. The signal word, defined below, indicates the severity of the hazard. The message after the signal word provides information for preventing or avoiding the hazard.

#### ⚠️ DANGER

Immediate hazards which, if not avoided, **WILL** result in severe injury or death.

#### ⚠️ WARNING

Hazards which, if not avoided, **COULD** result in severe injury or death.

#### ⚠️ CAUTION

Hazards or unsafe practices which, if not avoided, **MAY** result in injury or property damage.

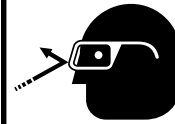

#### ⚠️ WARNING

Wear eye protection when operating or servicing this tool.

Failure to wear eye protection can result in serious eye injury from flying debris or hydraulic oil.



#### ⚠️ WARNING

Skin injection hazard:

Do not use hands to check for oil leaks. High pressure oil easily punctures skin causing serious injury, gangrene, or death. If injured, seek medical help immediately to remove oil.



#### ⚠️ WARNING

Do not use solvents or flammable liquids to clean the crimping tool. Solvents or flammable liquids could ignite and cause serious injury or property damage.

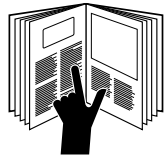

#### ⚠️ WARNING

Read and understand all of the instructions and safety information in this manual before operating or servicing this tool.

Failure to observe this warning can result in severe injury or death.



#### ⚠️ WARNING

Electric shock hazard:

This tool is not insulated. When using this unit near energized electrical lines, use proper personal protective equipment.

Failure to observe this warning can result in severe injury or death.

#### ⚠️ WARNING

An incomplete crimp can cause a fire.

- Use proper die, connector, and cable combinations. Improper combinations can result in an incomplete crimp.
- Use only W-type dies on aluminum connectors or aluminum wire. Mismatched components can result in an incomplete crimp.
- The relief valve will sound to indicate a completed crimp. If you do not hear the sound of the relief valve, the crimp is not complete.

Failure to observe these warnings can result in severe injury or death.



**Identification**

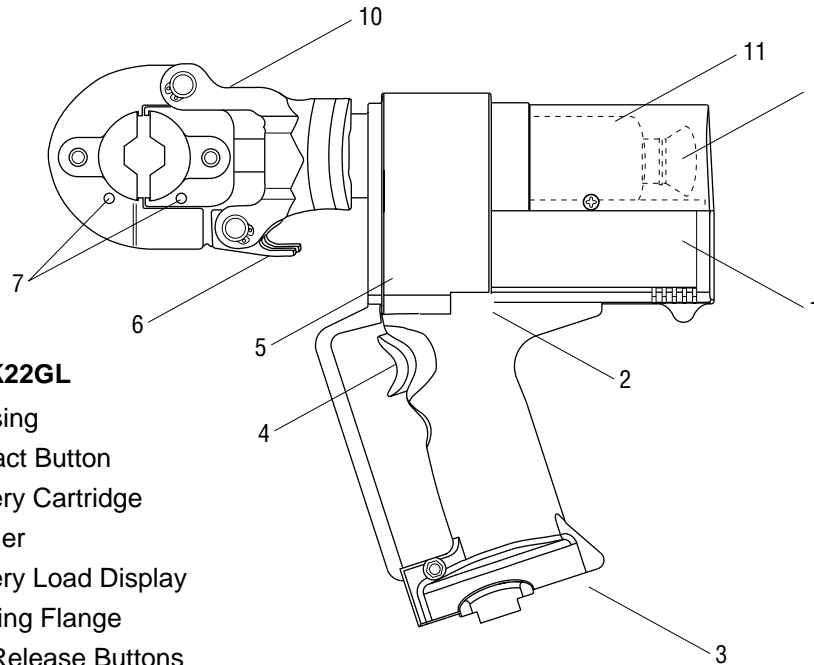

**EK22GL**

- 1. Housing
- 2. Retract Button
- 3. Battery Cartridge
- 4. Trigger
- 5. Battery Load Display
- 6. Locking Flange
- 7. Die Release Buttons
- 8. W-type Die Detents
- 9. Crimping Dies
- 10. Crimping Head
- 11. Oil Reservoir
- 12. Oil Plug

**Specifications**

**Crimping Tool**

Length .....	314 mm (12-3/8")
Width .....	76 mm (3")
Height .....	298 mm (11-3/4")
Mass/Weight (with battery) .....	4.4 kg (9.7 lb)
Sound Level .....	75 dB (A) at 1 meter
Vibration .....	< 2.5 m/s <sup>2</sup>
Motor Type .....	DC permanent field motor
Motor Voltage .....	12 VDC
Hydraulic Oil .....	50 ml (0.1 pint) of Shell Tellus® T 15

**Crimping Capacities**

Maximum Cable Size .....	600 Kcmil copper
Maximum Crimping Force .....	55 kN (6.2 tons)
Crimping Time .....	7 seconds
Crimps per Charge .....	approximately 120

**Battery**

Charging Voltage .....	12 V
Charging Time .....	1 hour

**Operation**

	<b>⚠ WARNING</b>
	<p>Electric shock hazard:</p> <p>This tool is not insulated. When using this unit near energized electrical lines, use proper personal protective equipment.</p> <p>Failure to observe this warning can result in severe injury or death.</p>

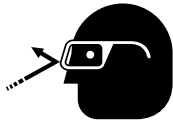
	<b>⚠ WARNING</b>
	<p>Wear eye protection when operating or servicing this tool.</p> <p>Failure to wear eye protection can result in serious eye injury from flying debris or hydraulic oil.</p>

	<b>⚠ WARNING</b>
	<p>Keep hands away from the crimping head when crimping.</p> <p>Failure to observe this warning can result in severe injury or death.</p>

<b>⚠ CAUTION</b>
<ul style="list-style-type: none"> <li>• Do not operate the tool without dies. Damage to the ram or crimping head can result.</li> <li>• Do not operate with the crimping head open. Damage to the ram or seals can result.</li> <li>• This tool is not designed for continuous use. After 30 to 40 crimping cycles, allow the crimping tool to cool for 15 minutes.</li> <li>• Do not place the tool in a vise. The crimping tool is designed for hand-held operation.</li> <li>• Protect the crimping tool from rain and moisture. Water will damage the crimping tool and battery.</li> <li>• Use this tool for the manufacturer's intended purpose only.</li> </ul> <p>Failure to observe these precautions can result in injury or property damage.</p>

**Charging the Battery**

Read the instructions supplied with the battery charger.

**Battery Condition**

Battery Load Display	Battery Condition
Momentary illumination at beginning of crimp	Normal or operating charge level
Flickering at point of maximum crimping force	Normal or operating charge level
Flickering during entire crimping cycle	Low charge level
Constant illumination when operating without a load	Low charge level

**Installing K22-type Dies**

1. Select the proper dies for the intended crimp.
2. Push the die release button.
3. Slide the die into the crimping head until it "snaps" into place.
4. Properly position the second die. Repeat Steps 2 and 3.

**Installing W-type Dies**

1. Push the die release button.
2. Slide the die adapter (Greenlee part number 500 4292.0) into crimping head until it "snaps" into place.  
*Note: The die adapters have the "D<sub>3</sub>" die profile. No additional dies are needed if the connector to be crimped requires a "D<sub>3</sub>" die.*
3. Repeat for the other adapter.
4. Select the proper dies for the intended crimp.
5. Press the locking flange and open the crimping head.
6. Push the W-type die detent and slide the W-type die into place.
7. Properly position the second die. Repeat Steps 5 and 6.

## Operation (cont'd)

### Preparing Cable

Follow the lug manufacturer's instructions for appropriate cable strip length.

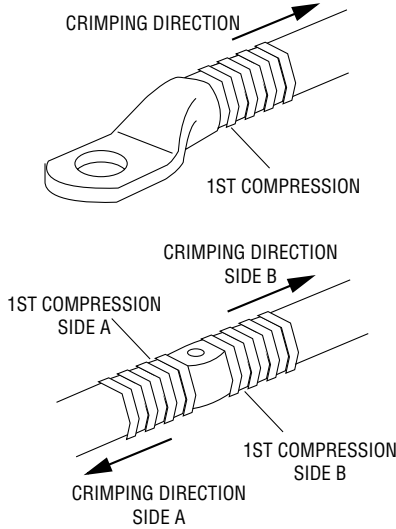

### Crimping Cable

1. Press the locking flange and open the crimping head.
2. Insert the properly assembled connector into the crimping head.
3. Close the crimping head.
4. Pull the trigger to make the crimp.
5. Hold the trigger down until the crimping tool achieves pressure relief.

*Notes: Pressure relief occurs at approximately 690 bar (10,000 psi) and is accompanied by an audible "pop".*

*It is normal for the battery load display to light at both the beginning and near the end of the crimping cycle.*

6. The crimping tool returns automatically.
7. Position the crimping tool for next crimp. Repeat Steps 4 through 6 for the number of crimps as described in this manual.
8. Open the crimping head and remove the connector.

*Notes: If it is necessary to retract the ram before a crimping cycle is completed, push the retract button. Pushing the retract button will result in the complete retraction of the ram.*

*After completing the last crimp with W-type dies on an aluminum connector, wipe off the excess oxide inhibitor.*

## **⚠ WARNING**

An incomplete crimp can cause a fire.

- Use proper die, connector, and cable combinations. Improper combinations can result in an incomplete crimp.
- Use only W-type dies on aluminum connectors or aluminum wire. Mismatched components can result in an incomplete crimp.
- The relief valve will sound to indicate a completed crimp. If you do not hear the sound of the relief valve, the crimp is not complete.

Failure to observe these warnings can result in severe injury or death.

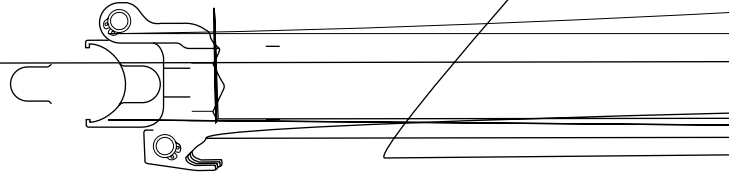

**Dies and Connectors**

**Die Selection**

Crimps made on copper cable with Greenlee K22-type dies and the connectors listed here are UL classified and CSA certified. Refer to "Connector Selection" for brand names and model numbers of appropriate lugs as well as crimping instructions.

W-type dies can be used to crimp #6 AWG to 4/0 AWG aluminum or copper cable.

Part Number	UPC Number	Cable Size	Color Code
K22-0	03079	#8 AWG	Red
K22-1	03080	#6 AWG	Blue
K22-2	03081	#4 AWG	Gray
K22-3	03082	#2 AWG	Brown
K22-31	03083	#1 AWG	Green
K22-4	03084	1/0 AWG	Pink
K22-5	03085	2/0 AWG	Black
K22-6	03086	3/0 AWG	Orange
K22-7	03087	4/0 AWG	Purple
K22-8	03088	250 Kcmil	Yellow
K22-9	03089	300 Kcmil	White
K22-10	03090	350 Kcmil	Red
K22-11	03091	400 Kcmil	Blue
K22-12	03092	500 Kcmil	Brown
K22-13	03093	600 Kcmil	Green

**Connector Selection**

EK22GL Crimping Range: #8 AWG to 600 Kcmil

When used with K22-type dies, this tool is UL classified and CSA certified for use with the following connector brands:

Connector Type	Barrel Type	Anderson	Blackburn®	Burndy	IlSCO	Panduit	T&B	Penn-Union	No. of Crimps*
Copper Splice	Short	VHSS	CPS	YS-L	CT	SCSS/SCS	54504-54520	BCU	A
	Long	VHS	CU	YS	CTL	SCL/SCH	54804-54820	BBCU	B
Copper Lugs	Short	VHCS	CTL-2/CTL	YA-2LN/YA-L/YA-2L YA/YA-L-TC/YA-L-2TC	CRA/CRB	LCAS/LCA LCD	54104-54120 54204-54218	BLU	A
	Long	VHCL	CTL-L/LCN	YA-2N	CRA-L/CRB-L CRA-2L/CRB-2L	LCB/LCC	54930BE-54920BE 54850BE-54878BE	BBLU	B



\* Use the number of crimps listed in the last column instead of the number provided with the connector:

- A — #8 to 1/0: 1 crimp  
2/0 to 600: 2 crimps
- B — #8 to 1/0: 2 crimps  
2/0 to 3/0: 3 crimps  
4/0 to 600: 4 crimps



## Maintenance

### Each Operating Day

Before use:

1. Inspect dies for wear or damage such as cracks, gouges, or chips.
2. Inspect the tool for damage or leaks. If damage is detected, return the tool to an authorized Greenlee service center for inspection.

	<b>⚠ WARNING</b>
	Skin injection hazard: Do not use hands to check for oil leaks. High pressure oil easily punctures skin causing serious injury, gangrene, or death. If injured, seek medical help immediately to remove oil.

After use:

1. Wipe all tool surfaces clean with a damp cloth and mild detergent.

	<b>⚠ WARNING</b>
	Do not use solvents or flammable cleaners to clean the tool body. Solvents could ignite, causing serious injury or property damage.

2. Fully retract the ram. Place the tool in the carrying case. Store in a cool, dry place.
3. Charge the battery.

### Monthly

1. Thoroughly clean all surfaces.
2. Check the oil level.
3. Oil the bolt joints.

### Annually or After 10,000 Crimps

1. Change the hydraulic oil.
2. Return the tool to an authorized Greenlee service center for inspection.

### Checking the Oil Level

1. Remove the two screws holding the tank housing cover.
2. Remove the tank housing cover.
3. Point the cutting head towards the ground and remove the oil plug. Add oil if necessary.
4. Replace the oil plug and the tank housing cover. Secure with screws.

### Recommended Hydraulic Oils

AVIA® HVI 15  
Shell Tellus T 15  
Mobil® DTE 11  
NUTO® H 15

## Troubleshooting

### Before You Begin

1. Make sure that the battery is charged. Recheck the battery after several minutes to make sure the battery is holding its charge.
2. Use a **nonflammable** contact cleaner or pencil eraser to clean the electrical contacts on the battery and crimping tool.
3. Reinstall the battery and check the tool again.

Problem	Probable Cause	Probable Remedy
Tool is inoperative.	Dirt, contaminants, etc., in ram area of tool.  Crimping tool battery contacts damaged.  Tool components worn or damaged.	Clean tool.  Reform contacts.  Return tool to an authorized Greenlee service center.
Dies stop during operation	Oil level is low.  Air in hydraulic system.	Check oil level. Refill reservoir.  Pull trigger and hold retract button simultaneously. Hold for approximately 10 seconds.
Battery load display flashes constantly.	Battery charge low.	Charge or replace battery.
Tool loses oil.	Damaged internal seal.  Oil plug not installed properly.	Return tool to an authorized Greenlee service center.  Refill reservoir and replace plug.

## Disassembly

### Main Components

1. Remove the battery.
2. Drive out the pin (37). Remove the die holder assembly (28).
3. Loosen two screws (24).
4. Unscrew and remove crimping head assembly.
5. Remove the spring (18) and piston (15). Replace the piston O-ring (12) and piston backup ring (13).
6. Unscrew two tank cover screws (55) and remove the tank cover.
7. Remove the hydraulic reservoir plug (76) and drain the hydraulic fluid.
8. Reinstall the plug.
9. Remove the remaining housing screws (51, 56, 57, 58).
10. Remove the left housing half.
11. Remove the switch cover (53).
12. Lift the pump/motor assembly and circuit card from the right housing half. Lift the LED from its housing (59).
13. Slide a plastic bag over the circuit card and electronic subassemblies. Tape the bag shut to protect the subassemblies from hydraulic oil and other contamination.
14. Unscrew the shoulder bolt (99) and remove the release lever (107).
15. Remove screws (108) and separate the gear housing/motor subassembly from the pump housing.

### Pump

1. Use a hooked tool to remove the reservoir O-ring (80). Gently tug it over the reservoir.
2. Remove the reservoir (74).
3. Remove the pump piston (152).
4. Remove the screw plug (151), washer (153), pump piston (150), valve stem (156), and spring (155). Replace the sealing washer (154).
5. Use a piece of tape to mark the side of the relief that is facing up. (This is a reference point for reassembly). Remove the unloading valve by unscrewing the plug (126).
6. Remove the feeder tube subassembly by unscrewing the feeder tube (78). Replace the oil filter (77). Remove metal chips from the magnet (82).
7. Remove the threaded bushing (72) and replace the O-ring (73).

### Motor, Gearbox, and Bearing

1. Remove the tamper-proof paper seal (96).
2. Remove two screws (92). Remove the end cap (102).
3. Apply pressure evenly at three points around the ball bearing (91) and gently pry the bearing up to remove it.
4. Remove the eccentric (103), grooved ball bearing (101), and snap ring (100) subassembly from the shaft.
5. Remove four screws (93). Remove the mounting block (109) from the gear housing (94).
6. Use a snap-ring removal tool to remove the snap ring (100).
7. Unscrew four bolts (not numbered) from the gear housing (94). Separate the gear housing from the spacer (not numbered). Unscrew two fillister head screws (112) to separate the spacer from the motor (90).

## Assembly

### Motor, Gearbox, and Bearing

1. Install two fillister head screws (112) into the spacer (not numbered) and motor (90). Tighten the screws.
2. Install four screws (not numbered) into the gear housing (94). Tighten the screws.
3. Install four screws (93) into the mounting block (109) and gear housing (94). Tighten the screws.
4. Replace the grooved ball bearing (101) and snap ring (100) subassembly.
5. Replace the eccentric (103). Use a fiber mallet to tap the eccentric onto the shaft. Replace the ball bearing (91).
6. Align the end cap (102). Use a fiber mallet to tap the cover until it is flush on the mounting block (109). Install two screws (92).
7. Align the gear housing/motor subassembly so that the pump piston (152) extends through the mounting block (109) and makes contact with the grooved bearing (101). Locate and start the screws (108) through the mounting block and into the pump housing. Tighten the screws.

### Pump

1. Insert the pump piston (152) into the pump housing.
2. Insert the seal (122) and unloading valve assembly into the pump housing. Grasp the needle valve subassembly by the pressure relief (126) and twist it several turns clockwise. Stop when the piece of tape is facing up.
3. Assemble the pump piston (150), valve stem (156), washer (153), spring (155), and screw plug (151). Be sure to replace the sealing washer (154). Torque the screw plug (151) to 101 Nm (75 ft-lb).
4. Install the release lever (107) so that the forked end engages the unloading valve subassembly between the pressure relief (126) and the support ring (127). Install the screw (99) and washer (104).
5. Insert the threaded bushing (79) and feed tube subassembly (77, 78, 82). Screw in until snug.
6. Install the reservoir (74). Slip the O-ring (80) over the reservoir. Using a hooked tool, carefully slip the O-ring over the lip of the pump housing.
7. Insert the plug (76) into the reservoir.

### Main Components

1. Remove the protective plastic bag from the electronics subassembly. Insert the LED into the LED bushing (59).
2. Lay the gear housing/motor subassembly into the right half of the housing. Insert the circuit board into the circuit board slot so that the wires and chip face in the direction of the trigger.
3. Lay the wires into the case. Be sure that the wires will not be pinched.
4. Guide the wires for the battery clip so that the battery wires lay on top of the electronics box; install the battery clip so that the red wire is upward.
5. Install the trigger cover (53) and plug (60). Press and release the trigger to be sure that it operates freely.
6. Locate the right housing half on top of the left housing half. Check for pinched wires.
7. Install the housing screws (51, 56, 57, 58).  
*Note: The handle screw (51) must engage the nut (52).*
8. Install the piston (15).
9. Install the spring (18).
10. Replace the front head assembly. Twist the head base (25) until it stops; back off 3/4 of a turn and tighten the screws (24). Be sure that the crimping head assembly rotates freely approximately 350°.
11. Install the die holder assembly (28). Insert the pin (37) through the ram.
12. Clamp the head assembly into a vise with the reservoir plug facing upward. Remove the fill plug (76) and fill the reservoir with hydraulic oil.
13. Install the battery.
14. Squeeze the trigger while pressing the release lever for 45 to 60 seconds. Fill the reservoir with hydraulic oil. Replace the fill plug (76).
15. Replace the tank cover and tank cover screws.

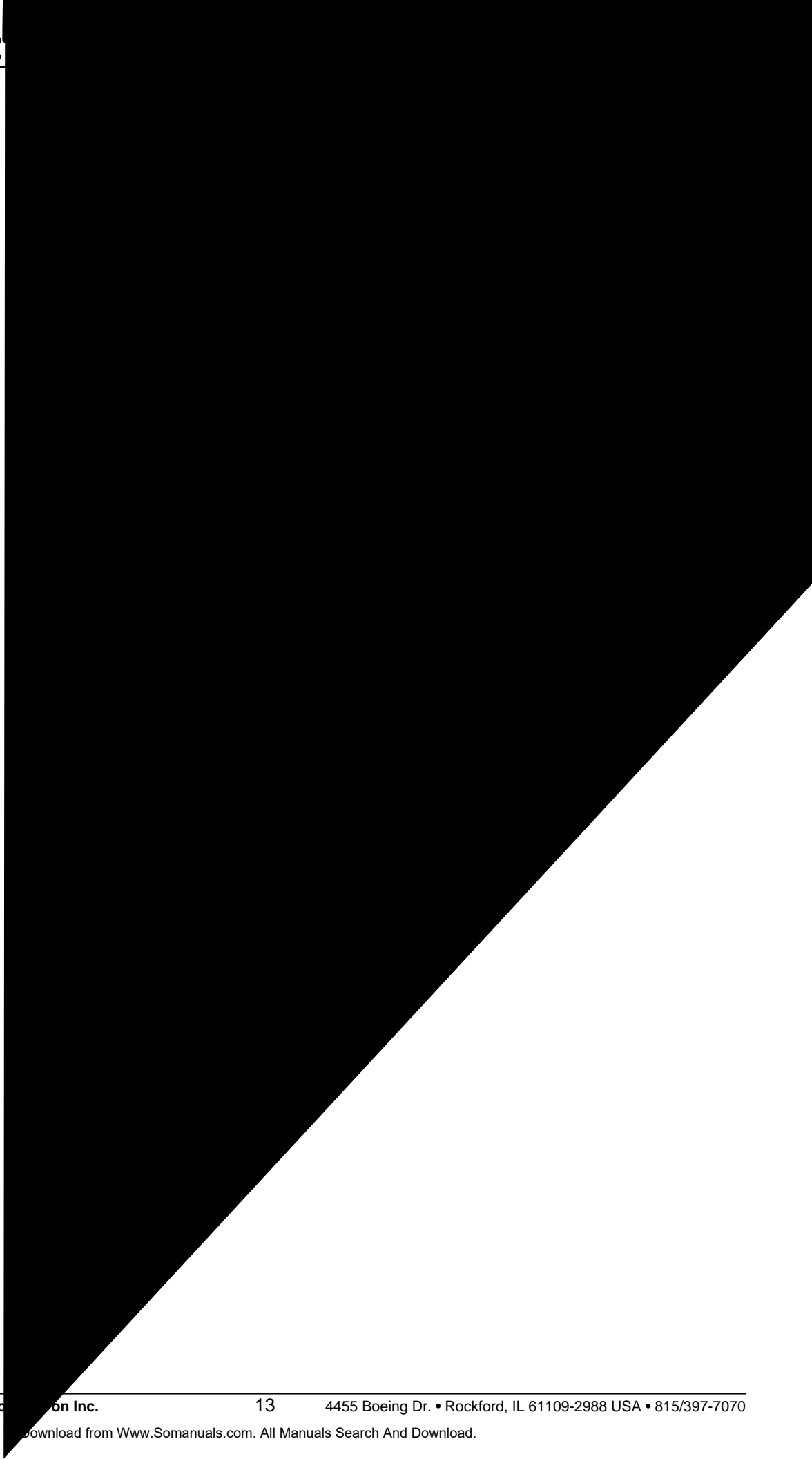

Illustration

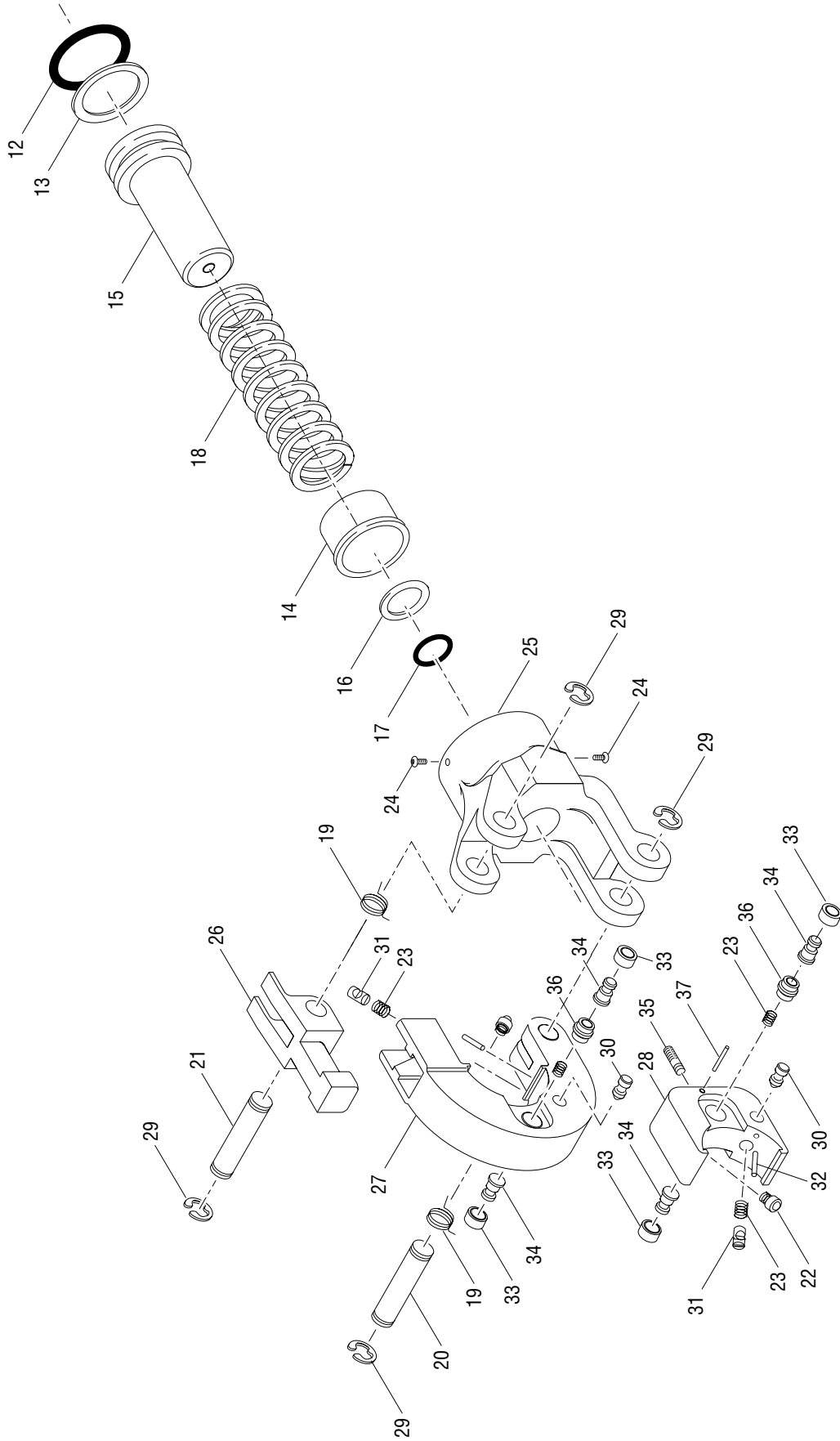

**Illustration**

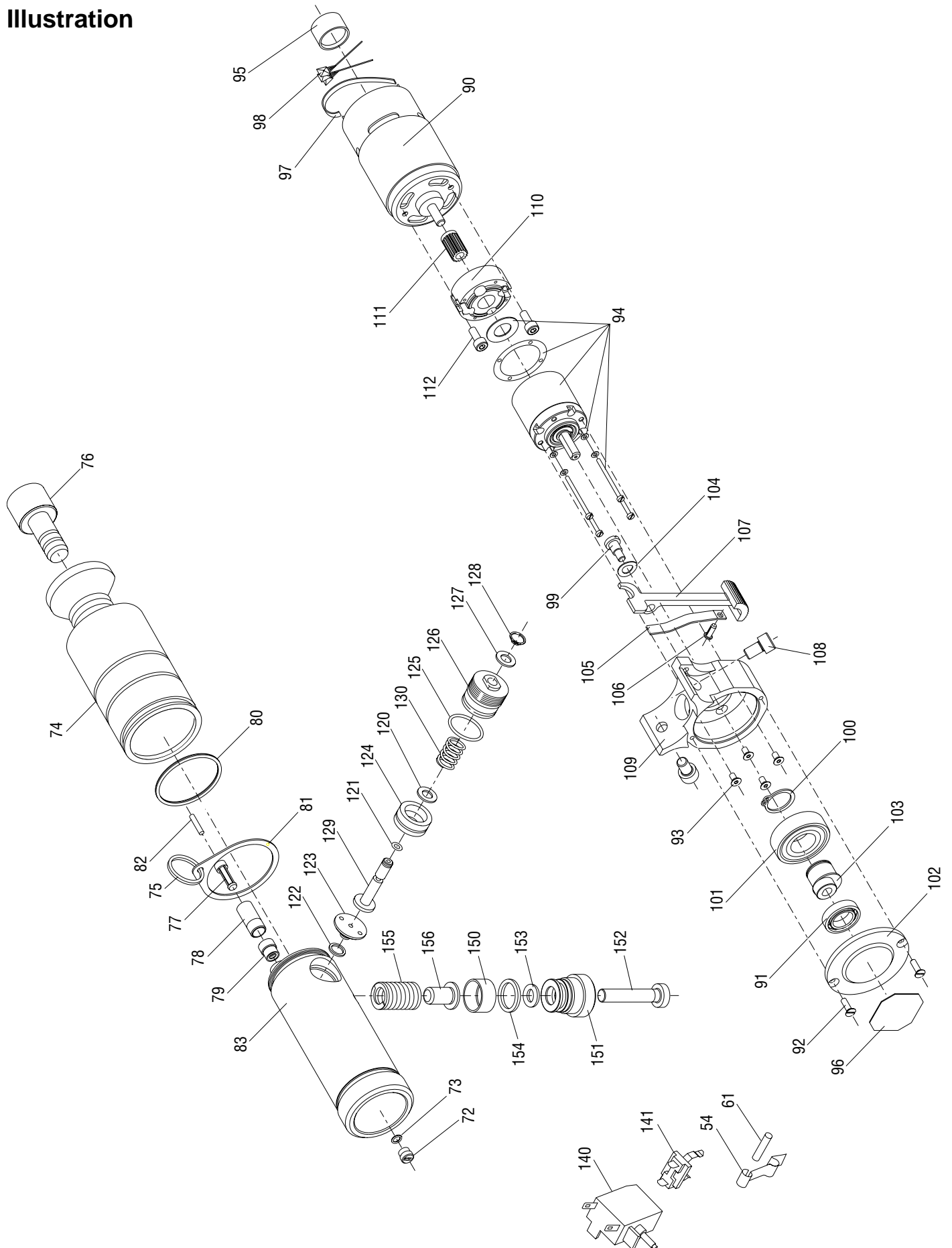

**Parts List**

Key	Part No.	Description	Qty
7	500 7151.3	Circuit board, programmed .....	1
9	500 2948.7	Decal, identification .....	1
10	500 2950.9	Decal, warning .....	1
11	500 6214.0	Decal, pinch hazard .....	2
12*	500 4192.4	O-ring .....	1
13*	500 4194.0	Backup ring .....	1
14	500 5844.4	Bushing .....	1
15	500 5834.7	Ram .....	1
16	500 5837.1	Adapter disk .....	1
17*	500 5838.0	O-ring .....	1
18	500 5839.8	Compression spring .....	1
19	500 4383.8	Spring .....	2
20	500 4384.6	Pin .....	1
21	500 4179.7	Pin .....	1
22	500 4385.4	Die retainer .....	2
23	500 4396.0	Compression spring .....	4
24	500 4168.1	Screw .....	2
25	500 5830.4	Bottom crimp head .....	1
26	500 4387.0	Latch .....	1
27	500 4388.9	Top die holder .....	1
28	500 4394.3	Bottom die holder .....	1
29	500 3430.8	Retaining ring .....	4
30	500 4400.1	Die release button .....	2
31	500 4401.0	Die retainer .....	2
32	500 4414.1	Pin .....	2
33	500 4389.7	Die release button .....	4
34	500 4390.0	Locking pin .....	4
35	500 4393.5	Threaded stud .....	1
36	500 4395.1	Inner bushing .....	2
37	500 4397.8	Pin .....	1
	500 1345.9	Housing unit (includes items 50–61)	
50	500 7142.4	Housing kit .....	1
51	500 4220.3	Screw .....	1
52	500 4221.1	Nut .....	1
53	500 7373.7	Switch cover .....	1
54	500 4128.2	Battery clip .....	1
55	500 4236.0	Screw .....	2
56	500 4207.6	Screw .....	4
57	500 4209.2	Screw .....	2
58	500 4208.4	Screw .....	4
59	500 4241.6	LED bushing .....	1
60	500 1350.5	Plug .....	1
61	500 3633.5	Pin, 4 x 16 .....	1



**Parts List (cont'd)**

Key	Part No.	Description	Qty
	500 1354.8	Pump housing, reservoir assembly (includes items 72–83)	
72	500 4144.4	Threaded bushing .....	1
73*	500 4143.6	O-ring .....	1
74	500 5861.4	Hydraulic reservoir .....	1
75	500 4198.3	Ring .....	1
76	500 4122.3	Reservoir plug .....	1
77	500 5880.0	Filter .....	1
78	500 5882.7	Filter adapter .....	1
79	500 5885.1	Threaded bushing .....	1
80*	500 5886.0	O-ring .....	1
81	500 5829.0	Attachment ring .....	1
82	500 5898.3	Magnet .....	1
83	500 1355.6	Pump housing .....	1
	500 1349.1	Motor assembly (includes items 90–112)	
90	500 4132.0	Motor .....	1
91	500 4138.0	Ball bearing .....	1
92	500 4155.0	Screw .....	2
93	500 4157.6	Screw .....	4
94	500 4133.9	Gearbox .....	1
95	500 4113.4	Spacer .....	1
96*	500 4153.3	Seal .....	1
97	500 4136.3	Ground strap .....	1
98	500 4137.1	Capacitor .....	3
99	500 4163.0	Screw, socket head .....	1
100	500 4151.7	Retaining ring .....	1
101	500 4139.8	Grooved ball bearing .....	1
102	500 4108.8	End cap .....	1
103	500 4123.1	Eccentric .....	1
104	500 4922.4	Lock washer .....	1
105	500 4125.8	Spring .....	1
106	500 5872.0	Screw .....	1
107	500 5879.7	Release lever .....	1
108	500 8403.8	Screw .....	2
109	500 8402.2	Eccentric case .....	1
110	500 1351.3	Gearbox .....	1
111	500 1352.1	Gear .....	1
112	500 6772.9	Screw .....	2

**Parts List (cont'd)**

Key	Part No.	Description	Qty
	500 1593.1	Relief valve assembly (includes items 120–130)	
120	500 5860.6	Washer .....	1
121*	500 4134.7	O-ring .....	1
122*	500 5862.2	Seal .....	1
123	500 5363.0	Valve seat.....	1
124	500 5864.9	Plunger .....	1
125*	500 5869.0	O-ring .....	1
126	500 5871.1	Pressure relief .....	1
127	500 5875.4	Support ring .....	1
128*	500 5876.2	Retaining ring .....	1
129	500 5877.0	Needle valve.....	1
130	500 5894.0	Spring .....	1
	500 1347.5	Electrical assembly (includes items 140–144)	
140	500 4126.6	Switch .....	1
141	500 4127.4	Battery contacts.....	1
142	500 6338.3	Circuit board, unprogrammed.....	1
143	500 5899.1	Wire (not shown) .....	1
144	500 5900.9	Wire (not shown) .....	1
	500 1348.3	Piston pump assembly (includes items 150–156)	
150	500 5891.6	Pump piston .....	1
151	501 0365.2	Screw plug.....	1
152	501 0370.9	Pump piston .....	1
153*	501 0369.5	Washer .....	1
154*	501 0366.0	Sealing washer .....	1
155	501 0367.9	Spring .....	1
156	501 0368.7	Valve stem.....	1
	500 4292.0	W-type die adapter	
	500 4625.0	W-type die release kit (includes items 23, 33, 34, 36)	
	500 4626.8	Die release kit (includes items 22, 23, 30–32)	
*	500 1407.2	Seal kit (includes items marked with an asterisk)	
	500 5954.0	Case with inserts	
	500 2999.1	12 V battery NiCd	
	500 3046.9	12 V charger 110 VAC	
	500 3047.7	12 V charger 220 VAC	
	500 3048.5	12 V charger 12 VDC	

**GREENLEE TEXTRON**

**Greenlee Textron / Subsidiary of Textron Inc.**

4455 Boeing Drive, Rockford, IL 61109-2988 USA

Customer Service (International): 815/397-7070 • Fax: 815/397-9247

Customer Service (North America): 800/435-0786 • USA Fax: 800/451-2632, 815/397-1865

Canada Fax: 800/524-2853

[www.greenlee.textron.com](http://www.greenlee.textron.com)

## Free Manuals Download Website

<http://myh66.com>

<http://usermanuals.us>

<http://www.somanuals.com>

<http://www.4manuals.cc>

<http://www.manual-lib.com>

<http://www.404manual.com>

<http://www.luxmanual.com>

<http://aubethermostatmanual.com>

Golf course search by state

<http://golfingnear.com>

Email search by domain

<http://emailbydomain.com>

Auto manuals search

<http://auto.somanuals.com>

TV manuals search

<http://tv.somanuals.com>