



REZNOR *Thomas & Betts*

Model CAUA Gas-Fired, Indoor, Vertical (Upflow) Power-Vented Heater

INSTALLATION FORM RZ 405 (Version B)
Obsoletes Form RGM 405 (Version A)

APPLIES TO: Installation

Table of Contents

Installation and Operation Paragraphs 1-18 Pages 1-18
 Optional Accessories Paragraphs 19-21 .. Pages 19-21
 Check Installation and Start-Up Paragraph 22 .. Pages 22-23

Index	By Page No.	Index	By Page No.	Index	By Page No.
Belt Drive	15	Discharge Plenum (Optional)	2, 21	Motor Amps	16
Blower Motor and Drive	15	Duct Connections	12	Mounting the Heater	2
Check/Test/Start-Up	22	Electrical Supply and Connections	14	Start-Up	22
Clearances	2	Filter Cabinet (Optional)	2, 20	Thermostat	14
Combustion Air	4	Gas Piping and Pressures	13	Uncrating and Preparation	2
Combustion Air Proving Switch	15	Gas Valve	16	Vent and Combustion Air	4
Concentric Adapter	2, 5	General	1	Determine Type of Vent	4
Condensate Drain	14	Hazard Intensity Levels	2	Power Vent Only Installation	10-11
Confined Space Installation	10	Ignition System	16	Separated-Combustion Installation ...	5-9
Cased Cooling Coil (Model ACU)	2, 19	Inlet Base (Optional)	2, 21	Warranty	2
Control Location Illustration	15	Installation Codes	2	Wiring Diagrams	17-19
Dimensions	3	Mixing Cabinet (Optional)	2, 21		

REFERENCES:

Operation/Maintenance/Service Manual, Form RZ 405-OMS
 Installation Manual for Model ACU Cooling Coil, RZ 405-CC
 Gas Conversion Instructions for Model CAUA, RZ 405-GC

Installation Manual for Optional Filter Cabinet, RZ 405-FC
 Installation Manual for Optional Mixing Box, RZ 405-MB
 Installation Instructions for Optional Inlet Base, RZ 405-IB
 Installation Instructions for Optional Discharge Plenum, RZ 405-DP

FOR YOUR SAFETY

What to do if you smell gas:

- Do not try to light any appliance.
- Do not touch any electrical switch; do not use any phone in your building.
- Immediately call your gas supplier from a neighbor's phone. Follow the gas supplier's instructions.
- If you cannot reach your gas supplier, call your fire department.

WARNING: Improper installation, adjustment, alteration, service, or maintenance can cause property damage, injury, or death. Refer to this manual. For assistance or additional information, consult a qualified installer, service agency, or the gas supplier.

WARNING: Gas-fired appliances are not designed for use in hazardous atmospheres containing flammable vapors or combustible dust. See Hazard Levels, page 2.

FOR YOUR SAFETY

Do not store or use gasoline or other flammable vapors and liquids in the vicinity of this or any other appliance.

GENERAL

Installation should be done by a qualified agency in accordance with the instructions in this manual and in compliance with all codes and requirements of authorities having jurisdiction. The instructions in this manual apply to the heater model shown below.

Model	Description
CAUA	Gas-Fired, Power-Vented, Vertical (Upflow) Heater

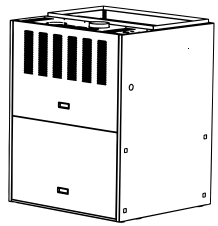

Model CAUA heaters are design-certified by the Canadian Standards Association (CSA) to ANSI Z83.6 and CGA 2.6-M96 for industrial/commercial installations in the United States and Canada. Heaters are available for use with either natural or propane gas. The type of gas, the firing rate, and the electrical characteristics are on the unit rating plate.

A Model CAUA heater requires installation of an inlet air duct or an optional inlet air base and a supply duct or an optional discharge plenum. This heater may be installed as a separated-combustion system (taking combustion air from outside) or as a power-vented system (taking combustion air from the space where the heater is installed).

GENERAL (Cont'd)

Separated-combustion units are designed to separate the air for combustion and the flue products from the environment of the building in which the unit is installed. Separated-combustion appliances are recommended for use in dust laden and some corrosive fume environments or in buildings with negative pressure (up to .15" w.c.). If installed as a separated-combustion system, the heater must be equipped with both combustion air and exhaust piping to the outdoors. All Model CAUA heaters must be vented to the outdoors.

WARNING: Should overheating occur, or the gas supply fail to shut off, shut off the manual gas valve to the appliance before shutting off the electrical supply.

WARNING: Do not use this appliance if any part has been under water. Immediately call a qualified service technician to inspect the appliance and replace any gas control which has been under water.

CAUTION: Do not locate the heater where it may be exposed to water spray, rain or dripping water.

HAZARD INTENSITY LEVELS

- 1. DANGER: Failure to comply will result in severe personal injury or death and/or property damage.**
- 2. WARNING: Failure to comply could result in severe personal injury or death and/or property damage.**
- 3. CAUTION: Failure to comply could result in minor personal injury and/or property damage.**

1. Installation Codes

These units must be installed in accordance with local building codes. In the absence of local codes, in the United States, the unit must be installed in accordance with the National Fuel Gas Code ANSI Z223.1a (latest edition). A Canadian installation must be in accordance with the CAN/CGA B149.1 and B149.2 Installation Code for Gas Burning Appliances and Equipment. These codes are available from CSA Information Services, 1-800-463-6727. Local authorities having jurisdiction should be consulted before installation is made to verify local codes and installation procedure requirements.

2. Warranty

Refer to the limited warranty information on the Warranty Card in the "Owner's Envelope".

Warranty is void if ...

- Wiring is not in accordance with the diagram furnished with the heater.
- The unit is installed without proper clearance to combustible materials.

3. Uncrating and Preparation

This unit was test operated and inspected at the factory prior to crating and was in operating condition. If the heater has incurred any damage in shipment, file a claim with the transporting agency.

Check the rating plate for the gas specifications and electrical characteristics of the heater to be sure that they are compatible with the gas and electric supplies at the installation site.

Read this booklet and become familiar with the installation requirements of your particular heater. If you do not have knowledge of local Form 405, Page 2

requirements, check with the local gas company or any other local agencies who might have requirements concerning this installation.

Before beginning, make preparations for necessary supplies, tools, and manpower.

Shipped-Separate Accessories

- Concentric Adapter and Vent Terminal** - If the heater is installed as a separated-combustion system, a concentric adapter assembly is required. The concentric adapter and parts are shipped in a separate carton. Be sure that the shipped-separate carton is at the installation site. See Paragraph 7A.
- Filter Cabinet** - The return air filter cabinet is shipped separately for field installation over the inlet air opening of the heater. The inlet air opening location is determined by the application. The filter cabinet can attach at the opening on either the rear, the left side, or right side of the unit. Follow the installation instructions included with the cabinet.
- Cased Cooling Coil** - Model ACU cooling coils are designed for the Model CAUA heaters. The coil cabinet is shipped separately for installation over the discharge opening of the heater.
- Mixing Cabinet** - If outside air is desirable, a mixing cabinet with dampers is available. The mixing cabinet is field attached to the rear of the unit. Check to be sure that the mixing box is the configuration ordered. Follow the installation instructions included with the shipped-separate package.
- Inlet Base** - If an optional inlet base is included, follow the instructions included with the inlet base to select the location. The heater mounts on the inlet base; heater has a bottom inlet air opening.
- Discharge Plenum** - The discharge plenum is shipped separately for installation over the discharge opening of the heater. If the discharge plenum and a cased cooling coil are part of the installation, the discharge plenum is factory attached to the cooling coil casing.

Also, shipped with the heater are the parts needed to install a condensate drain (needed if installing a cooling coil). Other shipped-separate options could include a gas shutoff valve, a thermostat, a thermostat guard, and/or a vent cap. Make sure all parts are at the site before beginning installation.

4. Clearances

Unit must be installed so that the clearances in the table are provided for service and inspection and for proper spacing from combustible construction.

Required Clearances (All Sizes)	
Right Side	0" (0mm)
Left Side	0" (0mm)
Front	36" (914mm)
Rear	0" (0mm)
Bottom	0" (0mm)
Flue Connector	6" (152mm)
Top	1" (25mm)

5. Mounting the Heater

Check the supporting structure to be used to verify that it has sufficient load-carrying capacity to support the weight of the unit. The heater must be level.

Approximate Net Weight (lbs)

Size	150	200	250	300	350	400
Weight (lbs)	288	300	380	394	445	460

WARNING: Unit must be level for proper operation. Do not place or add additional weight to the heater. See Hazard Levels, page 2.

Determine the position of the heater with regard to venting, combustion air, gas supply connection, electrical supply connection, and inlet air opening. Either cut out the inlet air opening (requires tin snips or aviation shears) now or when attaching ductwork or filter cabinet. Use caution when cutting the opening as the cut edges of the metal will be sharp. NOTE: If ordered with an optional inlet base, the heater is shipped with a bottom inlet air opening.

6. Dimensions

Figure 1 - Dimensions of Model CAUA

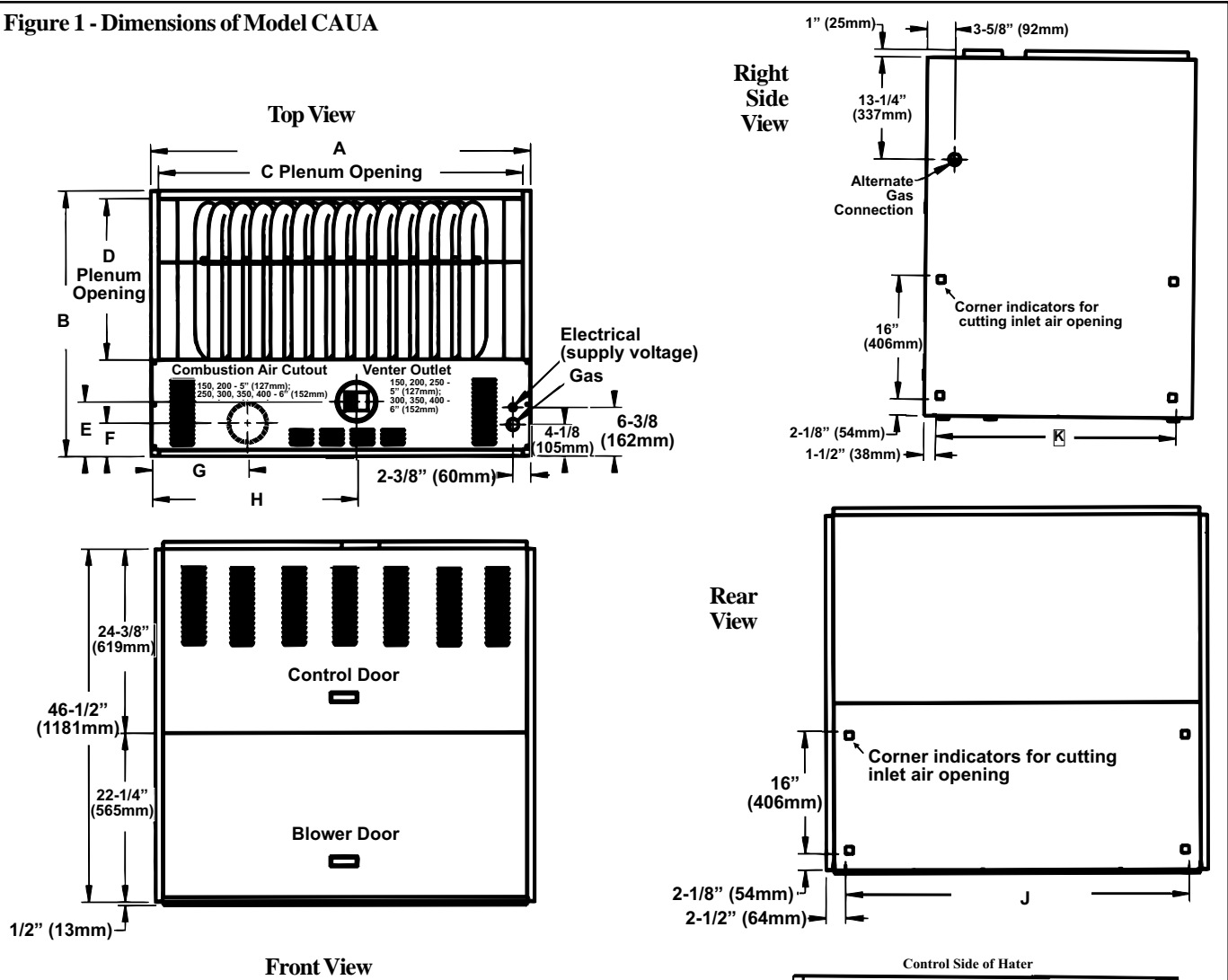

NOTE: Composite drawings are not proportional for all sizes.

Dimensions (inches + or - 1/8")

Size	A	B	C	D	E	F	G	H	J	K	M	N	P
150	38	34-3/4	36	21	7-1/4	3-3/4	12-1/2	24	33	31	19	34	4-5/8
200	38	34-3/4	36	21	7-1/4	3-3/4	12-1/2	24	33	31	19	34	4-5/8
250	50	34-3/4	48	21	7-1/4	4-3/8	12-3/4	27-1/4	45	31	16	46	4-3/4
300	50	34-3/4	48	21	7-1/4	4-3/8	12-3/4	27-1/4	45	31	16	46	4-3/4
350	50	49-3/4	48	34	7	4-3/8	14-1/8	26-3/4	45	44	32	46	4-7/8
400	50	49-3/4	48	34	7	4-3/8	14-1/8	26-3/4	45	44	32	46	4-7/8

Dimensions (mm +or- 3)

Size	A	B	C	D	E	F	G	H	J	K	M	N	P
150	965	883	914	533	184	95	318	610	838	787	483	864	117
200	965	883	914	533	184	95	318	610	838	787	483	864	117
250	1270	883	1219	533	184	111	324	692	1143	787	406	1168	121
300	1270	883	1219	533	184	111	324	692	1143	787	406	1168	121
350	1270	1238	1219	864	178	111	359	679	1143	1118	813	1168	124
400	1270	1238	1219	864	178	111	359	679	1143	1118	813	1168	124

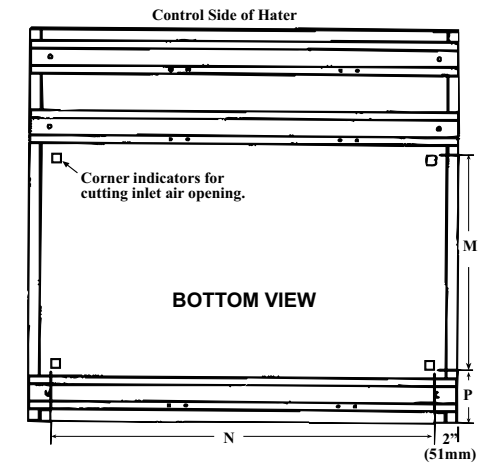

Air Opening Dimensions

Supply Air (Discharge with duct flange)	C x D
Inlet Air Opening (location selected by installer)	
Right Side of Heater	K x 16" (406mm)
Left Side* of Heater	K x 16" (406mm)
Rear of Heater	J x 16" (406mm)
Bottom of Heater	M x N

*Right side is illustrated; corner indicators for opening are the same on the left side.

7. Venting and Combustion Air

WARNING: The vent must be installed in accordance with national and local regulations. Failure to provide proper venting could result in death, serious injury and/or property damage. This unit must be installed with a vent to the outside of the building. Safe operation of any power-vented gas-fired equipment requires a properly operating vent system, correct provision for combustion air, and regular maintenance and inspection.

WARNING: Units installed in multiples require individual vent pipe runs and vent caps. Manifolding of vent runs is not permitted due to possible recirculation of combustion products into the building and back pressure effects on the combustion air proving switch.

Venting must be in accordance with the National Fuel Gas Code Z223.1 or CAN/CGA B149.1 and B149.2, Installation Code for Gas Burning Appliances and Equipment, and all local codes. Local requirements supersede national requirements. Combustion air for this heater may be either taken from the space or may be ducted from the outside using the

concentric adapter combustion air/vent system. Flue products must always be vented to the outdoors.

Installation should be done by a qualified agency in accordance with these instructions. The qualified service agency installing the vent or vent/combustion air system is responsible for the installation.

The venting or venting/combustion air systems illustrated in this manual are the only ones approved for a Model CAUA heater. However, since more than one system is approved and requirements vary depending on the type of installation, the first step must be deciding which vent or vent/combustion air system is going to be installed. Review the following matrix of vent types and installation requirements. If there is any doubt as to what type of vent is required, contact the equipment distributor before beginning installation.

Hazards of Chlorines - The presence of chlorine vapors in the combustion air of gas-fired heating equipment presents a potential corrosion hazard. Chlorine will, when exposed to flame, precipitate from the compound, usually freon or degreaser vapors, and go into solution with any condensation that is present in the heat exchanger or associated parts. The result is hydrochloric acid which readily attacks all metals including 300 grade stainless steel.

Care should be taken to separate these vapors from the combustion process. This may be done by installing a separated combustion system and/or wise location of the furnace with regard to exhausters or prevailing wind direction. Chlorine is heavier than air. This fact should be kept in mind when determining installation locations of heating equipment and building exhaust systems.

STEP 1 - Decide which Venting System to Install:

Type of Installation	Type of Vent System (Description/Instructions)	Vent Configuration/Options Required	Type of VENT Pipe* Required
COMMERCIAL/ INDUSTRIAL (Harmonized ANSI Z83.8-1996 and Canadian Standard CAN/CGA 2.6- M96)	Separated-Combustion (uses a power venter to duct combustion air from outdoors and exhaust flue products to the outdoors) - (follow Instructions in Section 7A)	Horizontal Vent / Option CC6 (includes concentric adapter box, exhaust terminal, and inlet air guard)	Use either vent pipe approved for a Category III appliance OR single-wall, 26-gauge or heavier galvanized (or a material of equivalent durability and corrosion resistance) vent pipe.
		Vertical Vent / Option CC2 (includes concentric adapter box, exhaust terminal, and combustion air inlet)	
	Power-Vented (uses a power venter to draw combustion air from the indoor space and exhaust flue products to the outdoors) - (follow Instructions in Section 7B)	Horizontal Vent / Option CC1 Vent Cap or field-supplied equivalent (see page 11)	Use either vent pipe approved for a Category III appliance OR appropriately sealed 26-gauge galvanized steel or equivalent single-wall pipe. If local code requires, the terminal section may be double-wall pipe with a single-wall vent run.
		At least 1/2 of the Equivalent Vent Length is Vertical / Option CC1 Vent Cap or field-supplied equivalent (see page 11)	Vent pipe listed above for a horizontal power-vented system may be used, OR vent pipe approved for a Category I heater may be used. Single-wall pipe or double-wall (Type B) vent pipe are suitable for use with a Category I heater. If local code requires, the terminal section may be double-wall pipe with a single-wall vent run.

STEP 2 - Follow the instructions that apply to the type of vent being installed

- **Separated-Combustion** -- requires air inlet pipe, exhaust vent pipe, and concentric adapter kit (Option CC2 or CC6)

Using required pipe (See Table above), FOLLOW INSTRUCTIONS IN SECTION 7A

- **Power Vent** -- requires vent pipe and vent cap (Option CC1 or field-supplied Type L Breidert Air-x-hauster® or equivalent vent cap)

Using required pipe (See Table above), FOLLOW INSTRUCTIONS IN SECTION 7B

7A. Venting and Combustion Air Requirements for Separated-Combustion Installation (must use either Option CC2 or CC6)

Specific Requirements (read all before installing)

Comply with the specific requirements and instructions in the following paragraphs and illustrations.

1. Combustion Air Inlet

Diameter is 5" for Sizes 150 and 200 and 6" for Sizes 250, 300, 350, and 400.

Use tin snips or aviation shears to cut out the hole in the top of the heater (See Figure 2). Insert the pipe through the hole and attach it to the collar inside the heater. Seal the joint. (Larger size heaters have oval collars. If the collar is oval, form the pipe to fit the collar.)

2. Venter Outlet

The venter outlet size is 5" for Sizes 150, 200, and 250 and 6" for Sizes 300, 350, and 400. A minimum length of 12" of straight pipe is required at the venter outlet.

3. Concentric Adapter

If installed as a separated-combustion unit, a concentric adapter is required.

- **Option CC2 and CC6** - The concentric adapter is a metal box that attaches to the inside of the building. See the illustrations and dimensions in Figures 3A and 3B. Option CC6 is horizontal; Option CC2 is vertical. (Option kits also include a vent terminal and combustion air inlet or guard.)

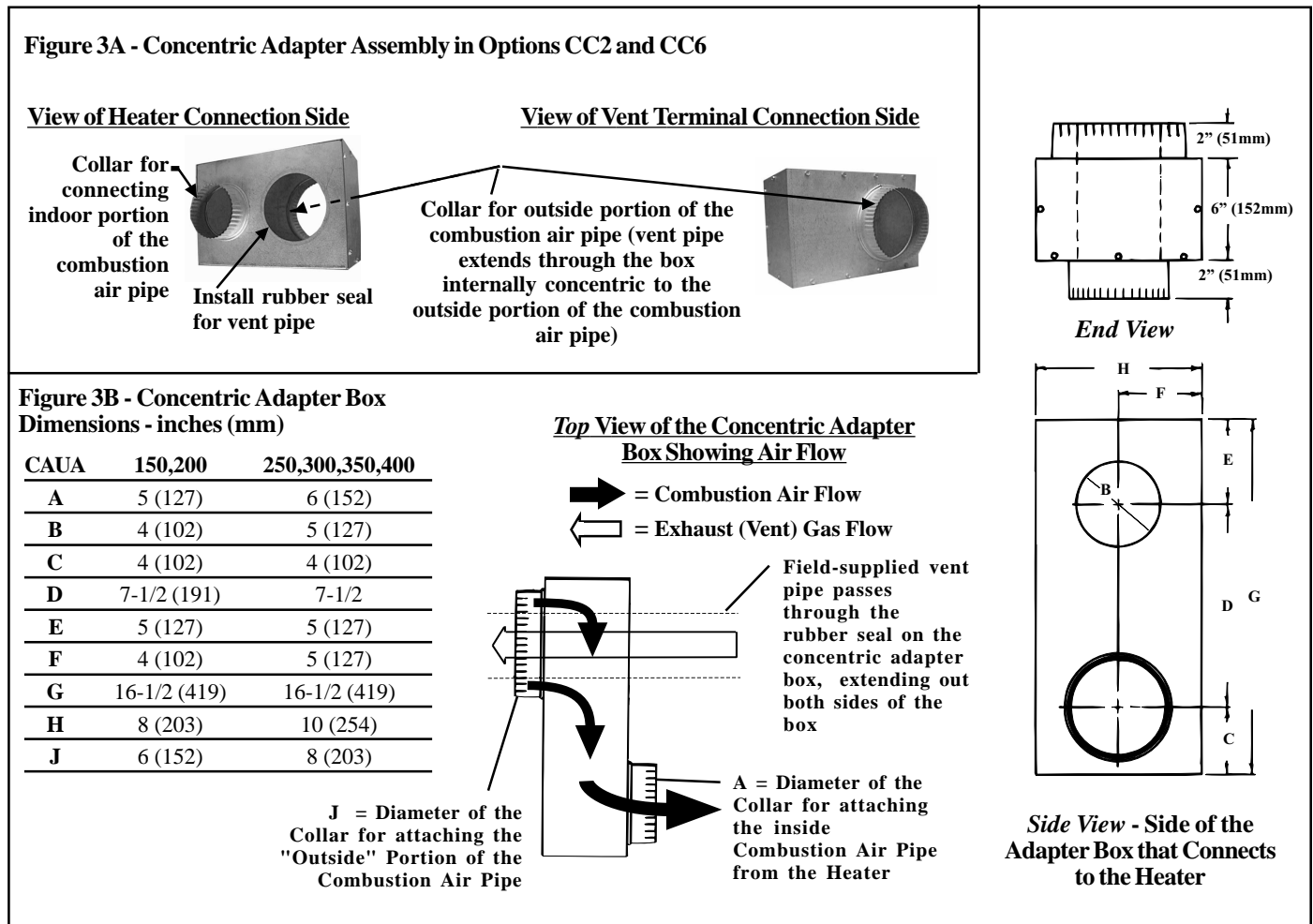
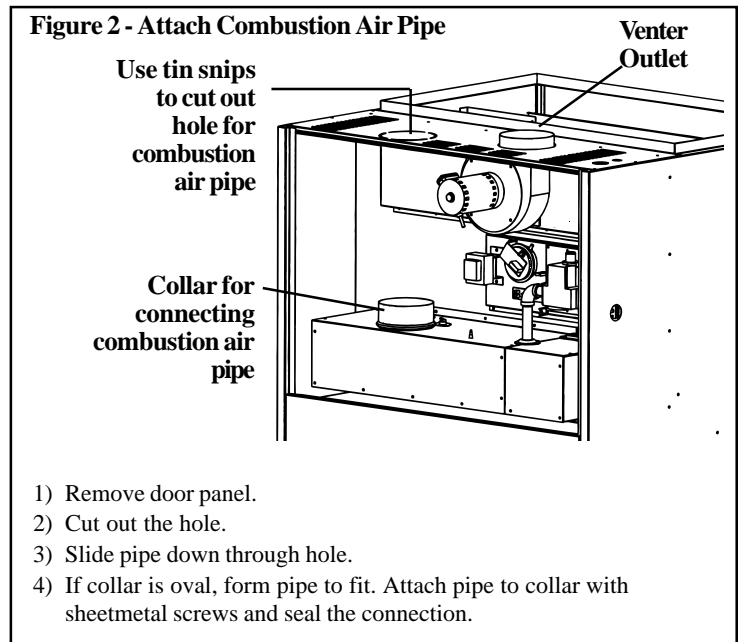

7. Venting and Combustion Air (cont'd)

7A. Venting and Combustion Air Requirements for Separated-Combustion Installation (must use either Option CC2 or CC6) (cont'd)

4. Pipe Diameter and Length

Maximum Pipe Length from Heater to Concentric Adapter - minimum length is five feet (1524mm)					
Model CAUA	Pipe Diameter		Maximum Length	90° Elbow Equals*	45° Elbow Equals*
	Vent	Inlet Air			
150-200	5"	5"	40 ft	5 ft	2.5 ft
			12.2 M	1524 mm	762 mm
250	5"	6"	50 ft	5 ft	2.5 ft
			15.2 M	1524 mm	762 mm
300-400	6"	6"	50 ft	5 ft	2.5 ft
			15.2 M	1524 mm	762 mm

*Reduce maximum length by this amount for each elbow.

Concentric Pipes (the vent pipe runs concentric through the outdoor portion of the combustion air pipe) - Sizes 150 and 200 require a 6" diameter combustion air pipe for outdoor portion and a 4" diameter vent pipe through the concentric adapter to the terminal; Sizes 250-400 require an 8" diameter combustion air pipe for the outdoor portion and a 5" diameter vent pipe through the concentric adapter to the terminal.

Length depends on building construction; specific requirements are included with the concentric adapter kit instructions.

5. Joints

Determined by type of pipe - Provide field-supplied vent pipe as specified in the Table on page 4.

- If using single wall, 26-gauge or heavier galvanized pipe, secure slip-fit connections using sheet metal screws or rivets. Seal all joints. Seal combustion air pipe with pressure sensitive tape ordinarily used for warm-air ductwork. Seal flue exhaust pipe with

either tape suitable for 550°F (such as Option FA1, P/N 98266) or high-temperature (450°F) silicone sealant.

- If using Category III vent pipe, follow the pipe manufacturer's instructions for joining pipe sections.

In Concentric Pipes (outdoor portion) from Concentric Adapter Box to Air Inlet and Vent Terminal - Follow the installation instructions for the specific option (CC6 for horizontal vent; CC2 for vertical vent).

Joints Requiring Taper-type Connections (See Figure 4) - When the diameter of the pipe in the vent pipe run is different from the vent pipe in the terminal section, the joint must be made with a taper-type pipe connector. Install the connector no more than 6" (152mm) from the concentric adapter box. A 5" to 4" reducer is required in the vent pipe on Sizes 150 - 200; a 6" to 5" reducer is required on Sizes 300 - 400.

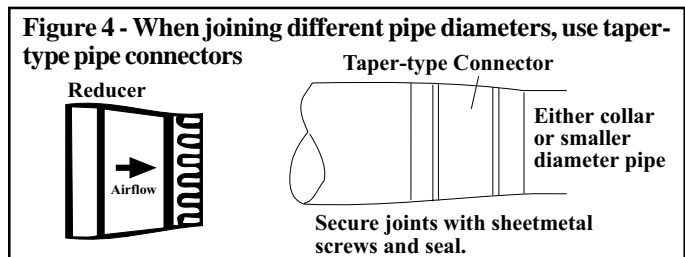

6. Support



Support horizontal runs every six feet (1829mm); do not rely on the heater or concentric adapter for support of either horizontal or vertical pipes.

7. Clearance

Clearance from the vent pipe to combustibles is 6" (152mm). Do not enclose the vent pipe.

Instructions and Requirements for Installing Horizontal Vent Terminal/Combustion Air Inlet Option CC6

Option CC6 Package includes:

Qty	Description	150, 200	250, 300, 350, 400
1	Complete Horizontal Vent Kit (Same as Option CC6)	157158	82131
1	Concentric Box Assembly (See Figures 3A and 3B)	155392	68404
1	Screened Exhaust Assy 	155096	53316
1	Inlet Guard 	151755	124940
4	#10-16x1/2" lg Screws (to attach the inlet guard)	37661	37661
1	Rubber seal for vent pipe opening in concentric adapter	164492	164493
1	Tube of high temperature (450°F) silicone sealant	53335	53335

Field-supplied installation requirements:

- Thimble (a thimble is not required if wall is of non-combustible construction)
- Flashing
- Vent pipes (see requirements on pages 4 and 6)
- Combustion air pipes (see requirements on pages 4 and 6)

- Mounting brackets for concentric adapter box (or box may be mounted flush, depending on building construction)
- Taper-type reducers as required (see requirements above)

Installation Instructions for Option CC6

1. Determine the location on the outside wall for the vent terminal (Applies to all horizontal vent kits). In most applications, the terminal would be on a level with the heater mounting height. Allow 1/4" per foot downward pitch toward the terminal for draining of condensation.

The distance of the termination of the horizontal vent from adjacent public walkways, adjacent buildings, openable windows, and building openings must be in accordance with local codes or, in the absence of local codes, must conform with National Fuel Gas Code. Local codes supersede all provisions in these instructions and in the National Fuel Gas Code. Minimum clearances for the horizontal vent terminal are as shown in the table on page 7.

Products of combustion can cause discoloration of some building finishes and deterioration of masonry materials. Applying a clear silicone sealant that is normally used to protect concrete driveways can protect masonry materials. If discoloration is an esthetic problem, relocate the vent or install a vertical vent.

WARNING: All vent terminals must be positioned or located away from fresh air intakes, doors and windows to preclude combustion products from entering occupied space. See Hazard Levels, page 2.

Structure	Minimum Clearances for Vent Termination Location (all directions unless specified)	
Forced air inlet within 10 ft (3.1m)	3 ft (0.9m) above	
Combustion air inlet of another appliance	6 ft (1.8m)	
Door, window, or gravity air inlet (any building opening)	4 ft (1.2m) horizontally	
	4 ft (1.2m) below	
	1 ft (30cm) above	
Electric meter, gas meter * and relief equipment	4 ft (1.2m)	*Do not terminate the vent directly above a gas meter or service regulator.
	horizontally	
Gas regulator *	3 ft (0.9m)	
Adjoining building or parapet	6 ft (1.8m)	
Adjacent public walkways	7 ft (2.1m) above	
Grade (ground level)	7 ft (2.1m) above	

2. Prepare clearance hole through the outside wall for a 6" diameter pipe (Size 150 or 200) or an 8" diameter pipe (Size 250, 300, 350, or 400). Outside wall construction thickness should be between 1" (25mm) minimum and 30" (762mm) maximum. The larger diameter combustion air pipe serves as clearance for the exhaust pipe on non-combustible construction. A thimble may or may not be required depending on wall construction and/or local codes.

3. Prepare the concentric adapter box.

3a) **Determine whether field-supplied brackets are required.** The box must be positioned so that the distance from the outside of the wall to the box is a minimum of 12" (305mm). Maximum distance is 60" (1524mm). If brackets are used, box should be angled slightly to allow for downward pitch of pipes. If used, attach brackets securely; do not leave any unsealed holes in the adapter box.

If brackets are not used, when the box is installed, position it tight against the wall.

3b) **Install the rubber seal and the vent pipe.** Locate the vent pipe opening (no collar) and place the rubber seal around and over the edge of the metal.

Determine the length of the section of vent pipe by adding the requirements. On the heater side of all Sizes except CAUA 250, the vent pipe must extend no more than 6" (152mm) (length limit does not apply to Size 250 because the pipe diameter does not change); plus 6" (152mm) through the box; plus bracket length; plus the width of the wall; plus a minimum of 18" (457mm)

Worksheet - Determine Length of Vent Pipe through the Box			
		inches	mm
Heater Side (max if diameter changes)	+	6	152
Width of Box	+	6	152
Bracket Length	+	—	—
Width of Wall	+	—	—
Terminal Side (min)	+	18	457
Length of Pipe	=		

on the outside (if the inlet air pipe extends recommended 2" (51mm) beyond the wall).

Lubricate the seal and pipe with liquid soap or a rubber lubricant. (Installation Tip: Spray cooking oil

works well as a lubricant for this task.)

Being sure the pipe is in the proper flow direction, slide the end through the box and push it *out through the rubber seal*. Push evenly using caution not to displace the seal from its position on the edge of the hole. If the rubber seal moves, slide the pipe back slightly, re-position the seal, and slide the pipe through again. Position the vent pipe so that it will extend a minimum of 16" past the end of the combustion air pipe. See

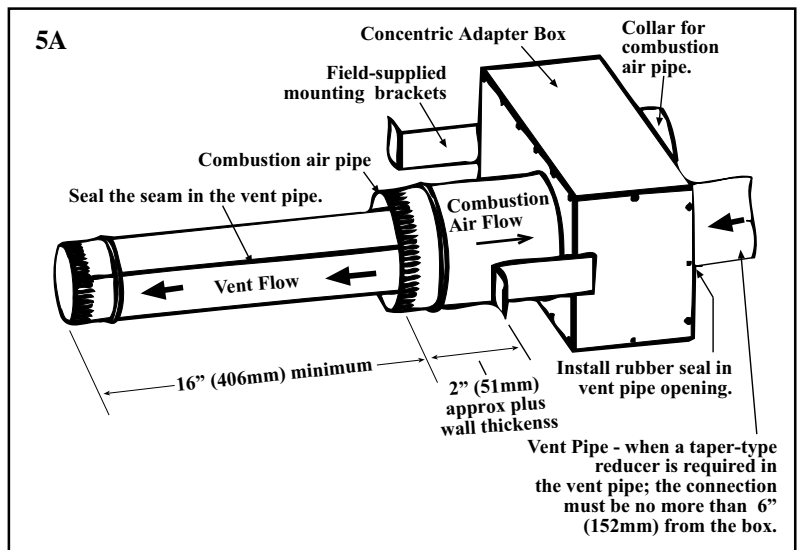
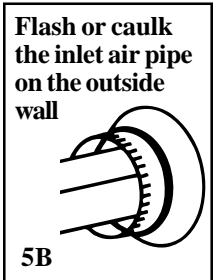

Figure 5A. On all Sizes except 250, no more than 6" (152mm) of vent pipe should extend out the heater side. Any time the pipe is re-positioned, re-check the seal to be sure that it has not rolled. Adjust the pipe and seal until the pipe is the correct length on each side of the box and the seal is over the edge of the hole and tight to the entire circumference of the pipe.

3c) **Attach the outside portion of the combustion air pipe to the box.** Determine the length by measuring the bracket length (if brackets are used), plus the wall thickness, plus 2" (51 mm). The inlet pipe should extend beyond the outside wall approximately 2" (51mm). Attach the inlet air pipe to the collar of the concentric adapter with sheetmetal screws being careful not to penetrate the vent pipe.

4. **Attach the concentric adapter box to the wall.** Insert the vent pipe and combustion air pipe through the wall. Push the concentric adapter box flush against the inside wall or attach to the wall with the field-supplied brackets. Caulk or flash inlet air pipe on the outside wall. Flashing is field supplied.



5. **Slide the inlet guard over the end of the vent pipe** and position it on the end of the combustion air pipe. See Figure 5B. Attach the guard to the inlet air pipe with the four 1/2" lg screws provided.

6. **Position the vent cap on the end of the vent pipe.** Align the cap so that its baffle strips are positioned on the horizontal and vertical centerlines (See Figure 5C). Attach the exhaust cap to the vent pipe with sheetmetal screws.

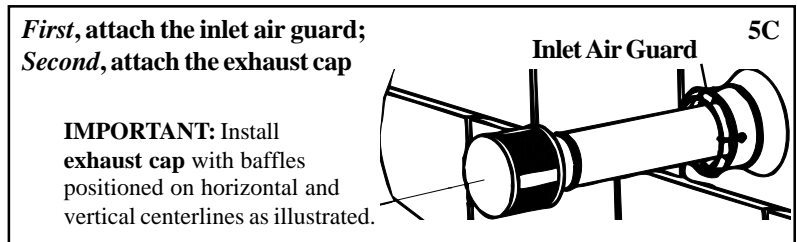

7. Horizontal vent terminal/combustion air inlet Option CC6 is installed and ready for connection to the heater.

8. **Connect the Concentric Adapter Box to the Heater** - Use the pipe specified and joints required for type of pipe. If collar or opening at the heater or adapter are different diameters from the pipe (use only diameters allowed on page 6), make joint connection with field-supplied taper-type reducer or enlarger.

A minimum of 12" (305 mm) of straight pipe is required at the vent outlet. Due to the high temperature, do not enclose the exhaust pipe or place pipe closer than 6" (152 mm) to combustible material.

Installation of the horizontal vent and combustion air system on your separated-combustion unit is complete. Refer to Figure 5D and verify that all installation requirements are met. Continue to Paragraph 8.

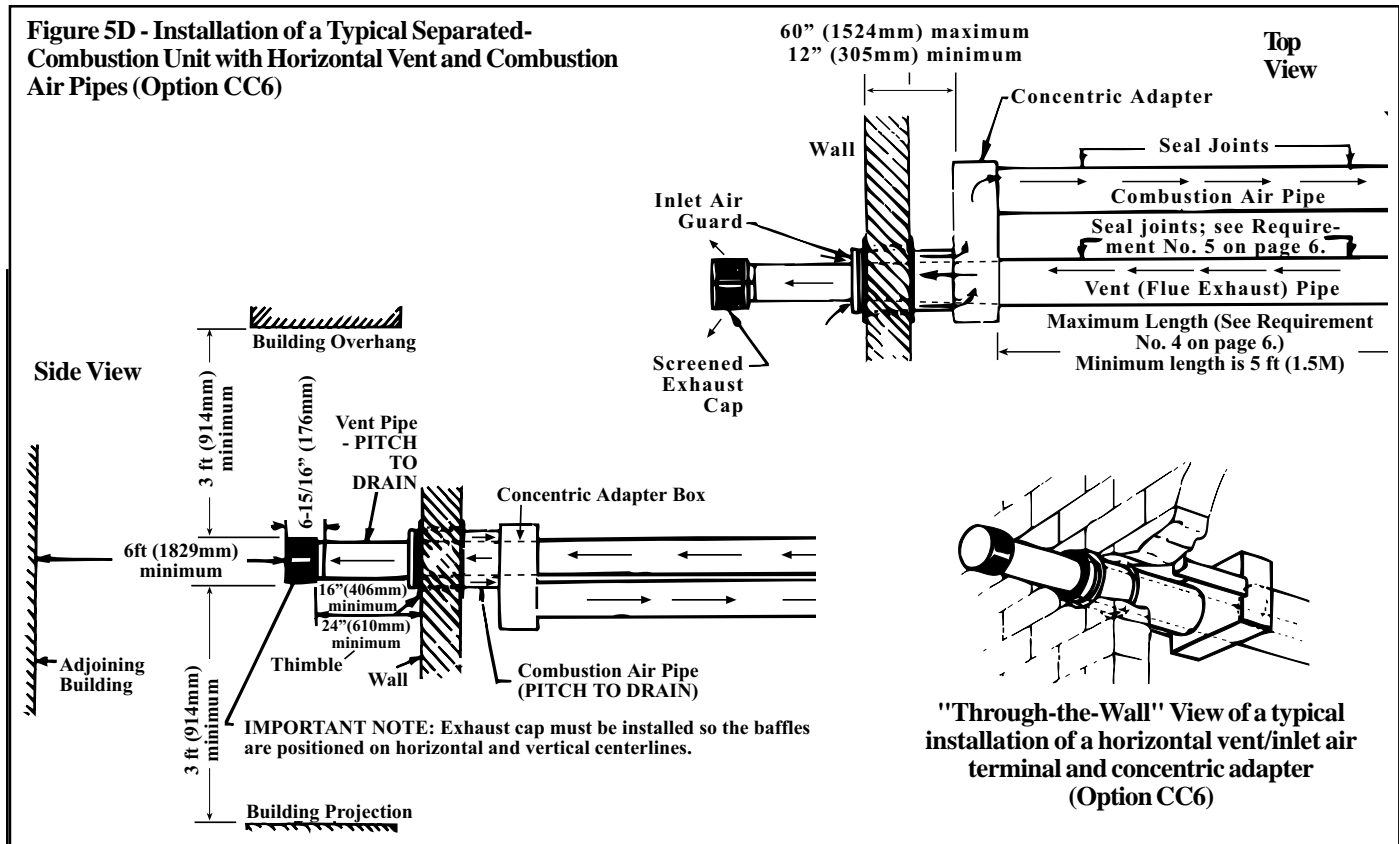

7. Venting and Combustion Air (cont'd)

7A. Venting and Combustion Air Requirements for Separated-Combustion Installation (must use either Option CC2 or CC6) (cont'd)



Instructions and Requirements for Installing a Vertical Vent Terminal/Combustion Air Inlet (Requires Concentric Adapter Kit, Option CC2)

Vertical Vent Terminal/Combustion Air Package (Option CC2) includes:

Qty	Description	150, 200	250,300, 350,400
1	Complete Vertical Vent Kit (Same as Option CC2)	157156	54444
1	Concentric Box Assembly	155392	68404
1	Exhaust Terminal 	155631	53326
1	Combustion Air Inlet 	155635	53330
1	Rubber seal for vent pipe opening in concentric adapter	164492	164493
1	Tube of High Temperature (450°F) Silicone Sealant	53335	53335

Field-supplied installation requirements:

- Thimble (a thimble is not required if wall is of non-combustible construction)
- Flashing
- Vent pipes (see requirements on pages 4 and 6)
- Combustion air pipes (see requirements, pages 4 and 6)
- Mounting brackets for concentric adapter box (or box may be mounted flush, depending on building construction)
- Taper-type reducers as required (see requirements on page 6)

Installation Instructions for Option CC2

1. Determine the location for the vent terminal on the roof, allowing room for the concentric adapter box inside. A thimble may or may not be required depending on building construction and/or local codes. Prepare a hole through the roof for the combustion air pipe (Sizes 150 and 200, pipe is 6"; Sizes 250-400, pipe is 8"). The air inlet pipe must be flashed or sealed to the roof. Flashing is to be supplied by the installer as required by roof construction and/or codes.

WARNING: All vent terminals must be positioned or located away from fresh air intakes, doors and windows to preclude combustion products from entering occupied space. See Hazard Levels, Page 2.

2. Prepare the concentric adapter box.

2a) **Determine whether field-supplied brackets are required.** If used, attach brackets securely; do not leave any unsealed holes in the adapter box.

If brackets are not used, when installed, the box should be tight against the roof.

2b) **Install the rubber seal and the vent pipe.** Locate the vent pipe opening and place the rubber seal around and over the edge of the metal. Determine the length of the section of vent pipe by adding the requirements. On the heater side of all Sizes except CAUA 250, the vent pipe must extend no more than 6" (152mm) (length limit does not apply to Size 250 be-

Worksheet - Determine Length of Vent Pipe through the Box

	inches	mm
Heater Side (max if diameter changes)	+ 6	152
Width of Box	+ 6	152
Bracket Length	+ —	—
Width of Roof	+ —	—
Inlet Pipe Height	+ —	—
Terminal Side (min)	+ 22	559
Length of Pipe	=	

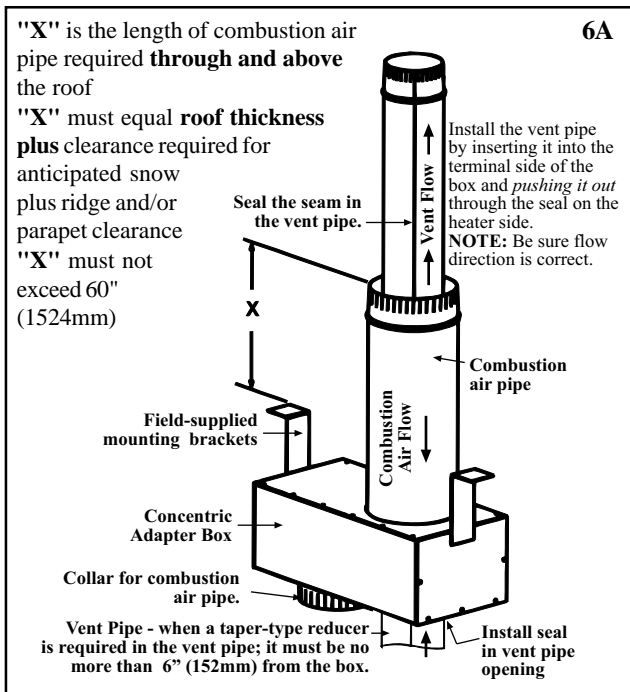

cause the pipe diameter does not change); plus bracket length; plus the width of the roof; plus the length of the outer inlet air pipe; plus a minimum of 22" (559mm).

Lubricate the seal and pipe with liquid soap or a rubber lubricant. (Installation Tip: Spray cooking oil works well as a lubricant for this task.) Being sure the pipe is in the proper flow direction, slide the end through the box and push it *out through the rubber seal*. Push evenly using caution not to displace the seal from its position on the edge of the hole. If the rubber seal moves, slide the pipe back slightly, re-position the seal, and slide the pipe through again.

Position the vent pipe so that it will extend a minimum of 22" (559mm) past the end of the combustion air pipe. See Figure 6B.

A maximum of 6" (152mm) of vent pipe should extend out the heater side. Any time the pipe is re-positioned, re-check the seal to be sure that it has not rolled. Adjust the pipe and seal until the pipe is the correct length on each side of the box and the seal is over the edge of the hole and tight to the entire circumference of the pipe.

2c) Attach the outside portion of the combustion air pipe to the box. Determine the length of the combustion air pipe so that dimension "X" (Figure 6A) is equal to the roof thickness, plus snow depth and ridge or parapet clearance, but does not exceed 60" (1524 mm). Attach the combustion air pipe to the collar with sheetmetal screws being careful not to penetrate the vent pipe.

3. Attach the concentric adapter. Insert the vent pipe and combustion air pipe up through the roof and secure the adapter box. Flash the combustion air pipe to the outside of the roof as required.

4. Slide the combustion air inlet over the

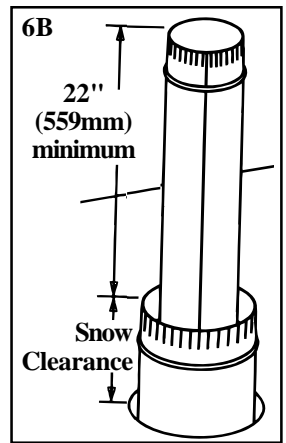

vent pipe and fasten the collar to the end of the combustion air pipe with sheet metal screws (See Figure 6C). Seal joint at top between vent pipe and combustion air inlet with silicone sealant to prevent water leakage.

5. Attach the exhaust terminal with sheet metal screws (See Figure 6D).

6. Vertical vent terminal/combustion air inlet is installed and ready for connection to the heater.

7. Connect Concentric Adapter Box to the Heater - Use the pipe specified and joints required for type of pipe. If collars at the heater or adapter are different diameters from the pipe (use only diameters allowed on page 6), make connection with field-supplied taper-type reducer or enlarger.

A minimum of 12" (305 mm) of straight pipe is required at the venter outlet. Due to the high temperature, do not enclose the vent pipe or place pipe closer than 6" (152 mm) to combustible material.

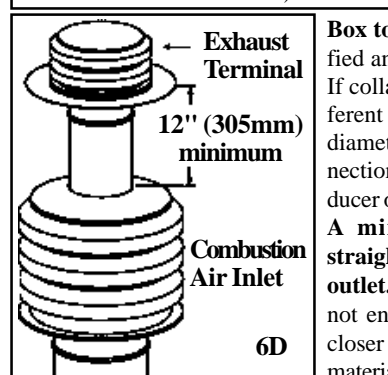
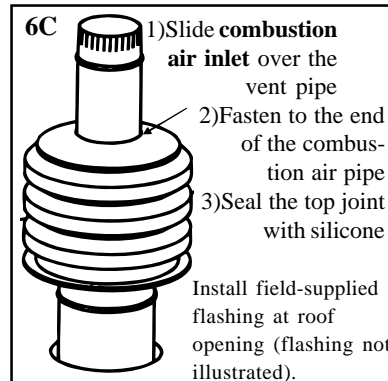

Installation of the vertical vent and combustion air system on your separated-combustion unit is complete. Refer to Figure 6E and verify that all installation requirements are met.

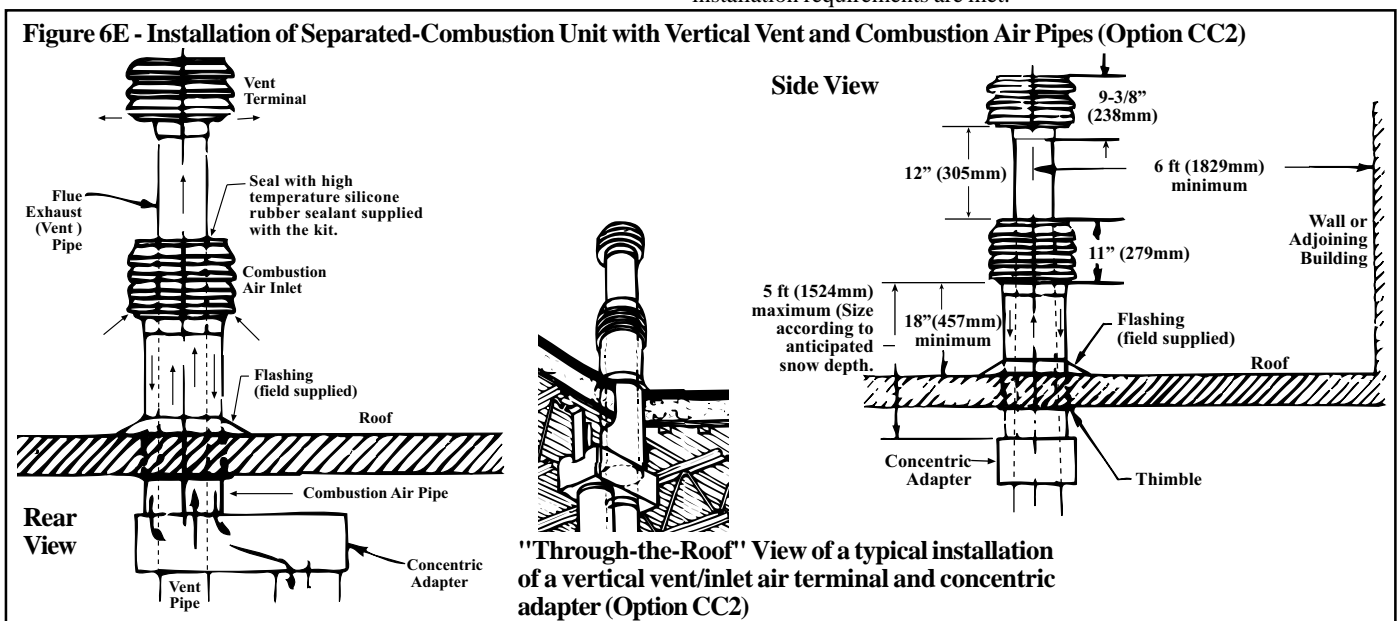

7. Venting and Combustion Air (cont'd)

7B. Venting and Combustion Air Requirements for Power Vent Drawing Combustion Air from THE INSIDE SPACE and Venting Flue Products to the Outdoors (vent cap is required)

If the environment has a positive pressure and is such that it is not detrimental to combustion air, this system may be installed. To provide combustion air to the heater sufficient air must enter the equipment location to replace that exhausted through the heater vent system. In the past, the infiltration of outside air assumed in heat loss calculations (one air change per hour) was assumed to be sufficient. However, current construction methods using more insulation, vapor barriers, tighter fitting and gasketed doors and windows, weather-stripping, and/or mechanical exhaust fans may now require the introduction of outside air through wall openings or ductwork to the equipment room.

The requirements for combustion and ventilation air depend upon whether the unit is located in a confined or unconfined space. An "unconfined space" is defined as a space whose volume is not less than 50 cubic feet per 1000 BTUH of the installed appliance. **Under all conditions**, enough air must be provided to ensure there will not be a negative pressure condition within the equipment room or space. Follow the specific requirements below for a confined space installation.

Confined Space Installation - Do not install a unit in a confined space without providing wall openings leading to and from the space. Provide openings near the floor and ceiling for ventilation and air for combustion as shown in Figure 7, depending on the combustion air source as noted in Items 1, 2, and 3 below.

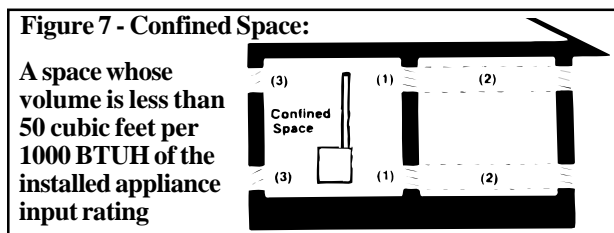

Add total BTUH of all appliances in the confined space and divide by figures below for square inch free area size of each (top and bottom) opening.

1. Air from inside the building -- openings 1 square inch free area per 1000 BTUH. Never less than 100 square inches free area for each opening. See (1) in Figure 7.

2. Air from outside through duct -- openings 1 square inch free area per 2000 BTUH. See (2) in Figure 7.

3. Air direct from outside -- openings 1 square inch free area per 4000 BTUH. See (3) in Figure 7.

NOTE: For further details on supplying combustion air to a confined space, see the National Fuel Gas Code ANSI Z223.1a (latest edition).

Specific Venting Requirements (read all before installing)

1) Venter (Flue) Outlet

Venter Outlet Size:

Model Size	150, 200, 250	300, 350, 400
Outlet Diameter	5"	6"

Venter Outlet Attachment Requirements:

- A minimum of 12" of straight pipe is required at the venter outlet before installing an elbow in the vent system. An elbow should never be attached directly to the venter. An elbow attached to the straight pipe can be in any position at or above horizontal. See Figure 8.

Form 405, Page 10

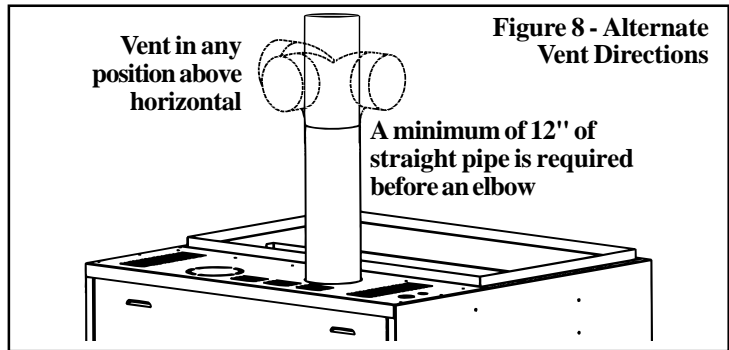

- Do not install dampers or any other type of flue restrictor device.

2) Vent Pipe Diameter and Length

Maximum Vent Length - minimum length is 5 ft (1.5M)				
CAUA	Pipe Diameter	Maximum Length	90° Elbow Equals*	45° Elbow Equals*
150-250	5"	50 ft (15.2M)	5 ft (1.5M)	2.5 ft (.8M)
300-400	6"	50 ft (15.2M)	5 ft (1.5M)	2.5 ft (.8M)

*Reduce by this amount for each elbow.

Note: If the system contains all vertical pipe or a combination of horizontal and vertical vent pipe, the Maximum Permissible Vent Length may be increased one foot (305mm) for each foot (305mm) of vertical rise up to a maximum increase of ten feet (3M).

3) Vent Pipe and Joints

Provide field-supplied vent pipe as specified in the Table on page 4.

- If using single wall, 26-gauge or heavier galvanized pipe, secure slip-fit connections using sheet metal screws or rivets. Seal pipe joints either with tape suitable for 550°F (such as Option FA1, P/N 98266) or high-temperature silicone sealant.
- If using Category III vent pipe, follow pipe manufacturer's instructions for joining pipe sections. When attaching Category III pipe to the venter outlet or the vent cap, make secure, sealed joints following a procedure that best suits the style of Category III pipe being used.
- If using double-wall (Type B) vent pipe (at least 1/2 of the equivalent vent length must be vertical), follow pipe manufacturer's instructions for joining pipe sections. For joining double-wall pipe to the venter outlet collar, single-wall pipe, and/or the vent cap, follow the instructions below:

Instructions for attaching double-wall (Type B) vent pipe to the venter outlet, a single-wall pipe run, or to the vent cap (use these instructions for either full length double-wall or terminal only):

Hardware and Sealant Required: 3/4" long sheetmetal screws; and a tube of high temperature silicone sealant

- Look for the "flow" arrow on the vent pipe; attach according to the arrow. Slide the pipe so that the venter outlet, the single-wall pipe, or the vent cap is inside the double-wall pipe.
- Drill a hole through the pipe into the outlet collar, the single-wall pipe, or the vent cap. (Hole should be slightly smaller than the sheet metal screw being used.) Using a 3/4" long sheet metal screw, attach the pipe. Do not overtighten. Repeat, drilling and inserting two additional screws evenly spaced (120° apart) around the pipe.
- Use silicone sealant to seal any gaps. If there is an annular opening, run a large bead of sealant in the opening. The bead of sealant must be large enough to seal the opening, but it is not necessary to fill the full volume of the annular area.

4) Vent System Support

Lateral runs should be supported every six feet (1.8M) using a non-combustible material, such as strap steel or chain. Do not rely on the heater for support of either horizontal or vertical vent pipe.

5) Condensation

Any length of single-wall vent pipe exposed to cold air or run through an unheated area or an area with an ambient temperature of 45°F or less must be insulated along its entire length with a minimum of 1/2" foil-faced fiberglass, 1-1/2# density insulation. Where extreme conditions are anticipated, install a means of condensate disposal.

6) Vent Terminal (Pipe and Vent Cap)

The vent system must be terminated with the type of vent cap approved for use with this heater. The vent cap must be the same size as the vent pipe. Use either a vent cap available from the

heater manufacturer (Option CC1) or a field-supplied cap. If the vent cap is field-supplied, use a Type L Breidert *Air-x-hauster*® or equivalent vent cap. (Type L *Air-x-hauster*® is a trademark of The G. C. Breidert Company.) Use of a vent cap supplied by the pipe manufacturer is not permitted; the vent cap must be the type approved for use with this heater. A different style vent cap could cause nuisance problems or unsafe conditions.

See the illustrations in Figures 9A and 9B for requirements of vertical and horizontal vent termination. The vent terminal pipe may be either single-wall or double-wall (Type B). If double-wall pipe is used in the vent terminal with a single-wall vent run, follow the instructions on page 10 to attach the vent cap and to connect the double-wall pipe to the single-wall vent pipe run.

Figure 8 - Horizontal Vent Terminals

Single-Wall Vent Run and Single-Wall Terminal

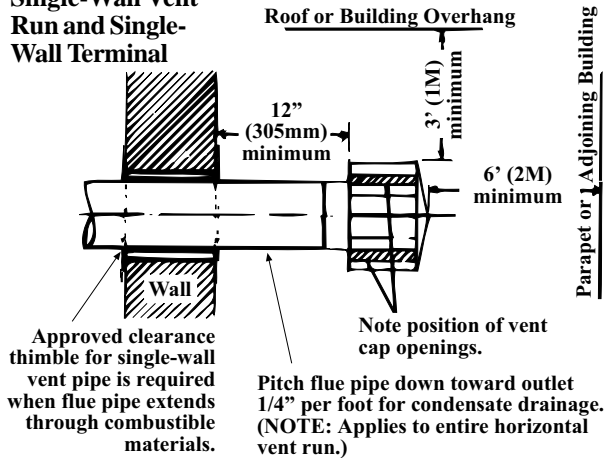

Single-Wall Vent Run and Double-Wall Terminal

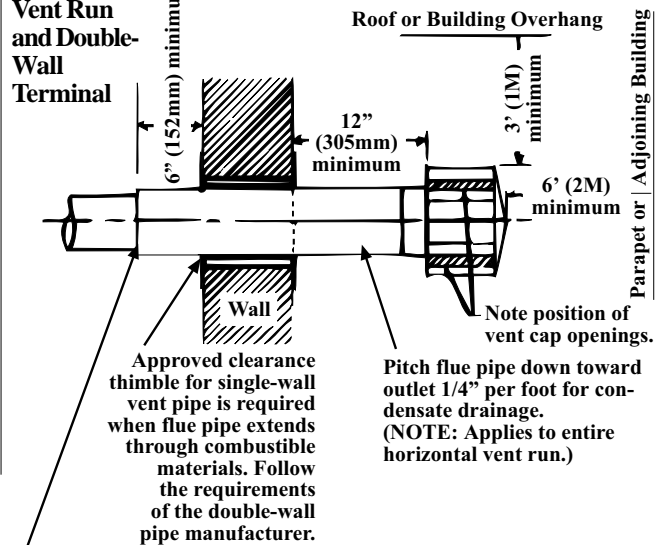

Horizontal Vent Terminal Clearances

A vent cap is required. Maintain a clearance of 12" from the wall to the vent terminal cap for stability under wind conditions.

Products of combustion can cause discoloration of some building finishes and deterioration of masonry materials. Applying a clear silicone sealant that is normally used to protect concrete driveways can protect masonry materials. If discoloration is an esthetic problem, relocate the vent or install a vertical vent.

Follow instructions on page 10 to join single and double-wall pipe and to seal the connection.

Structure	Minimum Clearances for Vent Termination Location (all directions unless specified)	
Forced air inlet within 10 ft (3.1m)	3 ft (0.9m) above	
Combustion air inlet of another appliance	6 ft (1.8m)	
Door, window, or gravity air inlet (any building opening)	4 ft (1.2m) horizontally	
	4 ft (1.2m) below	
	1 ft (30cm) above	
Electric meter, gas meter* and relief equipment	4 ft (1.2m) horizontally	*Do not terminate the vent directly above a gas meter or service regulator.
	Gas regulator*	
Adjoining building or parapet	6 ft (1.8m)	
Adjacent public walkways	7 ft (2.1m) above	
Grade (ground level)	7 ft (2.1m) above	

Figure 9 - Vertical Vent Terminals

Single-Wall Vent Run and Single-Wall Terminal

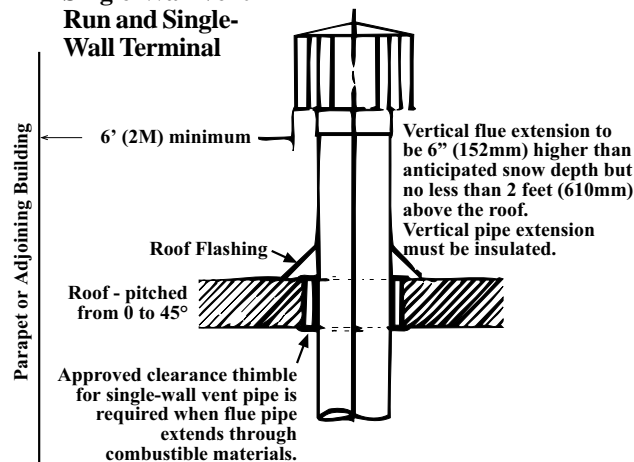

Single-Wall Vent Run and Double-Wall Terminal

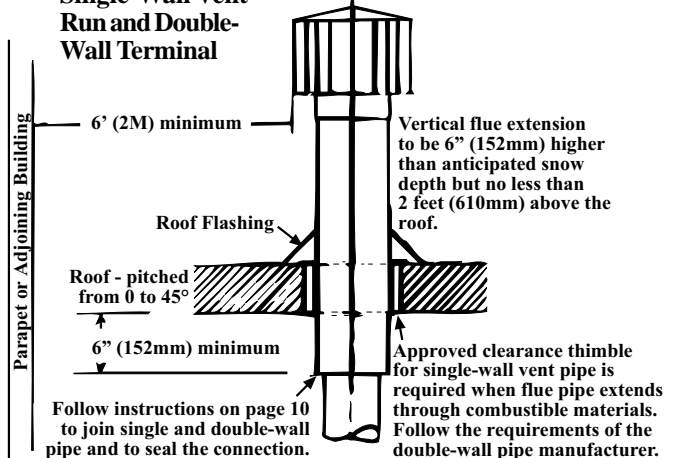

8. Duct Connections and Ductwork

Both inlet air ductwork and supply air discharge ductwork are **required** unless the heater is equipped with an optional inlet base and/or an optional discharge plenum. **IMPORTANT NOTE:** If a Model ACU cased cooling coil is part of the installation, it must be installed **before attaching discharge ductwork**. Installation of a filter cabinet is recommended when a cooling coil is installed.

Discharge Duct Connection - The discharge duct connects to the top of the heater or to the outlet of the optional cooling coil cabinet. See Figures 10 and 11. Connect the ductwork plenum to the duct flange as illustrated in Figure 11.

- 1) The duct connection on the top of the heater has a 90° flange.
- 2) The duct may either have no flange or a 90° flange.
- 3) Position ductwork around the outside of the heater flange.
- 4) If the ductwork has a flange, drill holes vertically through duct flange into the top of the heater and secure with sheetmetal screws. If the ductwork does not have a flange, drill holes horizontally through the ductwork and the heater flange; secure with sheetmetal screws.

Figure 10 - Top View showing Discharge Duct Connection Dimensions (inches)

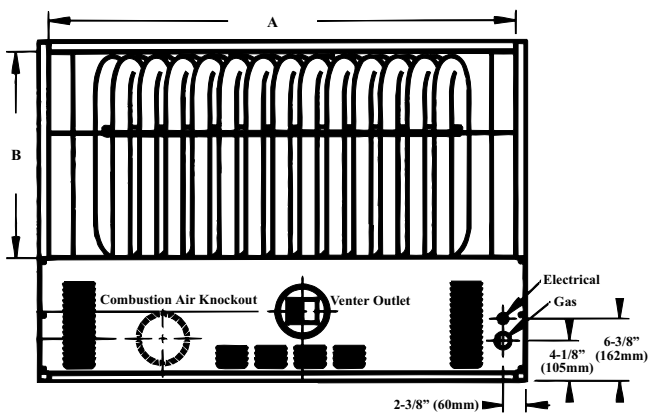

Size	150, 200	250, 300	350, 400
A	36" (914mm)	48" (1219mm)	48" (1219mm)
B	21" (533mm)	21" (533mm)	34" (864mm)

Figure 11 - Connecting Discharge Ductwork

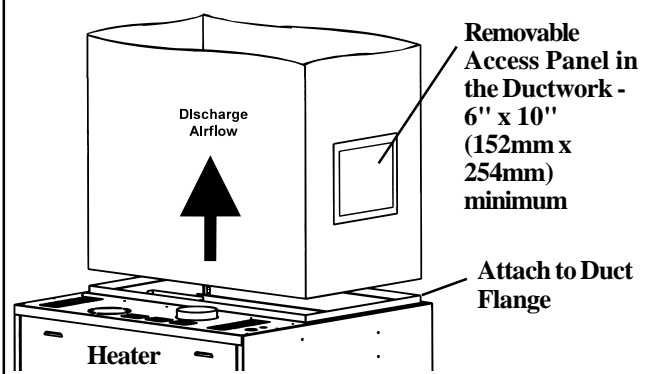

Inlet Air Ductwork - The location of the inlet air duct connection depends on the installation. Corner indicators for the opening are provided on the right side, the left side, and the rear of the heater. (See Dimensions in Figure 1, page 3.) Determine where the inlet air opening(s) should be and cut out using tin snips or aviation shears. **CAUTION:**

Form 405, Page 12

The cut edges of the metal will be sharp.

If installing an optional filter or filter/mixing cabinet shipped with the heater, attach the cabinet at the "cutout" opening (See Optional Accessories, Paragraph 18 or 19). Depending on the cabinet and how it is installed, the inlet opening may be horizontal or vertical.

Attach the ductwork to the heater or to the inlet cabinet.

Figure 12 - Duct Opening for Connecting the Inlet Air Duct to the field-installed Filter or Mixing Cabinet

Depending on the heater size and whether the cabinet is on the side or the rear, the inlet opening may be either vertical (on the top of the filter cabinet) or horizontal (on the side of the filter cabinet.)

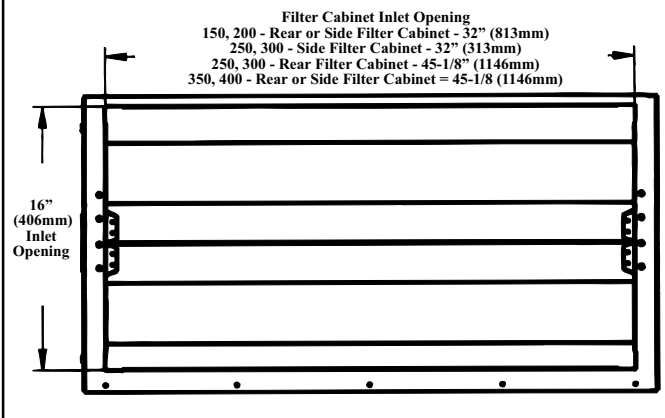

Requirements and Suggestions for Connecting and Installing Ducts

- **Type of Ductwork** - The type of duct installation to be used depends in part on the type of construction of the building.
- **Ductwork Material** - Rectangular duct should be constructed of not lighter than No. 26 U.S. gauge galvanized iron or No. 24 B & S gauge aluminum.
- **Ductwork Structure** - All duct sections 24 inches or wider, and over 48 inches in length, should be cross broken on top and bottom and should have standing seams or angle-iron braces. Joints should be S and drive strip, or locked.
- **Through Masonry Walls** - No warm air duct should come in contact with masonry walls. Insulate around all air duct through masonry walls with not less than 1/2" (1" is recommended) of insulation.
- **Through Unheated Space** - Insulate all exposed warm air ducts passing through an unheated space with at least 1/2" (1" is recommended) of insulation.
- **Duct Supports** - Suspend all ducts securely from buildings members. Do not support ducts from unit duct connections.
- **Duct Sizing** - Proper sizing of the supply air ductwork is necessary to ensure a satisfactory heating installation. The recognized authority for such information is the Air Conditioning Contractors Association, 1228 17th Street N.W., Washington, D.C. 20036. A manual covering duct sizing in detail may be purchased directly from them.

CAUTION: An external duct system static pressure not within the limits shown on the rating plate, or improper motor pulley or belt adjustment, may overload the motor. See Hazard Levels, page 2.

- **Removable Panels** - The ducts should have removable access panels on both upstream and downstream sides of the furnace. These openings must be accessible when the furnace is in service and should be a minimum of 6" x 10" in size so smoke or reflected light may be observed inside the casing to indicate the presence of leaks in the heat exchanger. The covers for the openings must be attached in such a manner as to prevent leakage. See Figure 11.

9. Gas Piping and Pressures

WARNING: This appliance is equipped for a maximum gas supply pressure of 1/2 pound, 8 ounces, or 14 inches water column. Supply pressure higher than 1/2 pound requires installation of an additional lockup-type service regulator external to the unit.

PRESSURE TESTING SUPPLY PIPING

Test Pressures Above 1/2 PSI: Disconnect the heater and manual valve from the gas supply line which is to be tested. Cap or plug the supply line.

Test Pressures Below 1/2 PSI: Before testing, close the manual valve on the heater.

All piping must be in accordance with requirements outlined in the National Fuel Gas Code ANSI Z223.1a (latest edition) or CAN/CGA-B149.1 and B149.2 (See Paragraph 1). Gas supply piping installation should conform with good practice and with local codes.

Unit heaters are orificed for operation with natural gas having a heating value of 1000 (\pm 50) BTUH per cubic ft or propane gas with a heating value of 2550 BTUH per cubic ft. If the gas at the installation site does not meet these specifications, consult the factory for proper orificing.

Pipe joint compounds (pipe dope) shall be resistant to the action of liquefied petroleum gas or any other chemical constituents of the gas being supplied.

Install a ground joint union and manual shutoff valve upstream of the unit control system as shown in Figure 13. The 1/8" plugged tapping in the shutoff valve provides connection for a supply line pressure test gauge. The National Fuel Gas Code requires the installation of a trap with a minimum 3" drip leg. Local codes may require a minimum drip leg longer than 3" (typically 6"). Bleed gas lines of trapped air.

Gas connection is either 1/2" or 3/4" depending on size and type of gas.

Size	Gas	Gas Connection
150-200	Natural	1/2"
250-400	Natural	3/4"
150-400	Propane	1/2"

Leak-test all connections by brushing on a leak-detecting solution.

Sizing a Gas Supply Line

Capacity of Piping - Cubic Feet per Hour based on 0.3" w.c. Pressure Drop Specific Gravity for Natural Gas -- 0.6 (Natural Gas -- 1000 BTU/Cubic Ft) Specific Gravity for Propane Gas -- 1.6 (Propane Gas -- 2550 BTU/Cubic Ft)												
Length of Pipe	Diameter of Pipe											
	1/2"		3/4"		1"		1-1/4"		1-1/2"		2"	
	Natural	Propane	Natural	Propane	Natural	Propane	Natural	Propane	Natural	Propane	Natural	Propane
20'	92	56	190	116	350	214	730	445	1100	671	2100	1281
30'	73	45	152	93	285	174	590	360	890	543	1650	1007
40'	63	38	130	79	245	149	500	305	760	464	1450	885
50'	56	34	115	70	215	131	440	268	670	409	1270	775
60'	50	31	105	64	195	119	400	244	610	372	1105	674
70'	46	28	96	59	180	110	370	226	560	342	1050	641
80'	43	26	90	55	170	104	350	214	530	323	990	604
90'	40	24	84	51	160	98	320	195	490	299	930	567
100'	38	23	79	48	150	92	305	186	460	281	870	531
125'	34	21	72	44	130	79	275	168	410	250	780	476
150'	31	19	64	39	120	73	250	153	380	232	710	433
175'	28	17	59	36	110	67	225	137	350	214	650	397
200'	26	16	55	34	100	61	210	128	320	195	610	372

Note: When sizing supply lines, consider possibilities of future expansion and increased requirements. Refer to National Fuel Gas Code for additional information on line sizing.

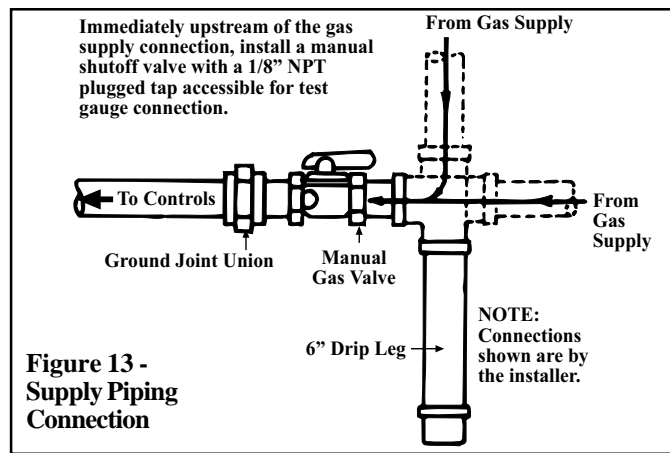

Figure 13 - Supply Piping Connection

WARNING: All components of a gas supply system must be leak tested prior to placing equipment in service. NEVER TEST FOR LEAKS WITH AN OPEN FLAME. Failure to comply could result in personal injury, property damage or death.

Manifold or Orifice Pressure Settings

Measuring manifold gas pressure cannot be done until the heater is in operation. It is included in the steps of the "Check-Test-Start" procedure in Paragraph 22. The following warnings and instructions apply.

WARNING: Manifold gas pressure must never exceed 3.5" w.c. for natural gas or 10" w.c. for propane gas.

For Natural Gas: Manifold gas pressure is regulated by the combination valve to 3.5" w.c. Inlet pressure to the valve must be a minimum of 5" w.c. or as noted on the rating plate and a maximum of 14" w.c.

For Propane Gas: Manifold gas pressure is regulated by the combination valve to 10" w.c. Inlet pressure to the valve must be a minimum of 11" w.c. and a maximum of 14" w.c.

Before attempting to measure or adjust manifold gas pressure, the inlet

9. Gas Piping and Pressures (cont'd)

Manifold Pressure Settings (cont'd)

(supply) pressure must be within the specified range for the gas being used both when the heater is in operation and on standby. Incorrect inlet pressure could cause excessive manifold gas pressure immediately or at some future time.

Instructions to Check Manifold

Pressure (when unit is operating):

1) With the manual valve positioned to prevent flow to the main burners, connect a manometer to the 1/8" pipe outlet pressure tap in the valve. NOTE: A manometer (fluid-filled gauge) is recommended rather than a spring type gauge due to the difficulty of maintaining calibration of a spring type gauge.

2) Open the valve and operate the heater. Measure the gas pressure to the manifold. Normally adjustments should not be necessary to the factory preset regulator.

If adjustment is necessary, set pressure to correct settings by turning the regulator screw IN (clockwise) to increase pressure. Turn regulator screw OUT (counterclockwise) to decrease pressure.

10. Burner Condensate Drain

If an optional cooling coil is installed on a Model CAUA heater (either now or at a later time), a burner condensate drain line *must* be installed.

The following parts to install the drain line are packaged and shipped with all Model CAUA heaters.

Qty	P/N	Description
1	165955	6-ft length of 3/8" I.D. Tubing
1	165952	90° Nylon Fitting, 1/4" NPT x 3/8" tubing
1	110628	1/4" NPT Brass Nut
1	171527	1/4" Locknut, Hex, T& B 139
1	165953	Sealing Washer
2	20913	Nylon Wire Ties, T&B #TY-24M
1	87556	Snap Bushing, Heyco SB 625-8

Instructions for Installing the Burner Condensate Drain (Figure 14)

1. Remove the burner compartment door.
2. The burner box cover is in two sections. On the left side of the burner box cover, disconnect the flame sensor wire and the flame rollout switch wires. Disconnect the silicone tubing from the static tap. Remove the left section of the burner box cover.
3. Determine which side of the cabinet will be most convenient for the drain line. Remove the hole plug on that side and insert the snap bushing from the package.
4. Locate the hole in the bottom center of the burner pan and remove the plug. Follow the instructions in Figure 14 to install the drain. Complete all steps as listed in the illustration.

When installation of the burner condensate drain is complete, re-assemble the heater.

Figure 14 - Burner Condensate Drain Connection

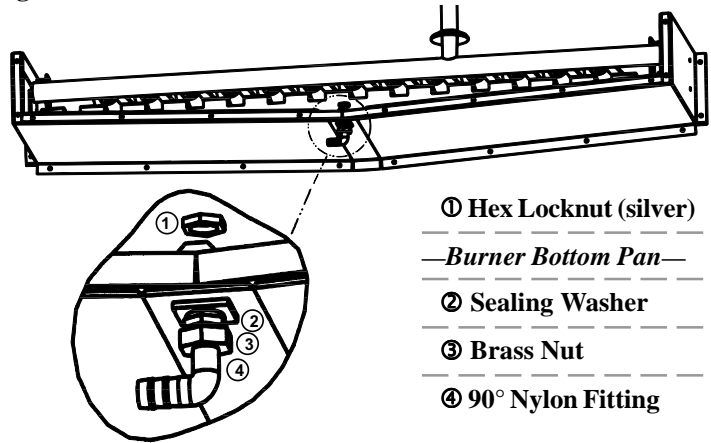

- 1) Assemble the brass nut, the sealing washer, and the 90° fitting.
- 2) Position the threaded fitting up through the hole so that the hose barb is toward the bushing in the side of the cabinet. Attach using the silver-colored locknut.
- 3) Under the burner, push the tubing onto the hose barb, being sure that it is secure. Maintaining a downward slope, extend the hose out through the cabinet side.
- 4) Just after exiting the cabinet, **create a trap in the line by making a loop in the hose**. Secure the loop with the wire ties.
- 5) Continue downward with the tubing, connecting it into the coil drain pipe.

11. Electrical Supply and Connections

All electrical wiring and connections, including electrical grounding, **MUST** be made in accordance with the National Electric Code ANSI/NFPA No. 70 (latest edition) or, in Canada, the Canadian Electrical Code, Part I-C.S.A. Standard C22.1. In addition, the installer should be aware of and comply with any local ordinances or gas company requirements.

Check the rating plate on the heater for the supply voltage and current requirements. A separate line voltage supply with fused disconnect switch should be run directly from the main electrical panel to the heater. All external wiring must be within approved conduit and have a minimum temperature rise rating of 60°C. Conduit from the disconnect switch must be run so as not to interfere with the service panels of the heater.

The electrical supply and control wiring enter at the top of the heater (See Figure 1, page 3) and connect to the terminal strip behind the gas valve (See Figure 15). Consult the wiring diagram supplied with your heater. Typical wiring diagrams are on pages 17 and 18.

CAUTION: If any of the original wire as supplied with the appliance must be replaced, it must be replaced with wiring material having a temperature rating of at least 105°C, except for sensor lead wires which must be 150°C. See Hazard Levels, page 2.

12. Thermostat and Connections

A thermostat is not standard equipment but is an installation requirement. Use either an optional thermostat available with the heater or a field-supplied 24-volt thermostat. Install according to the thermostat manufacturer's instructions. Control wiring enters on the right side of the heater and connects to the terminal strip in the control compartment; see Figure 15.

Make sure that the heat anticipator setting on the thermostat is in accordance with the amperage value noted on the wiring diagram of your heater.

WARNING: If you turn off the power supply, turn off the gas. See Hazard Levels, page 2.

Figure 15 - Control Locations

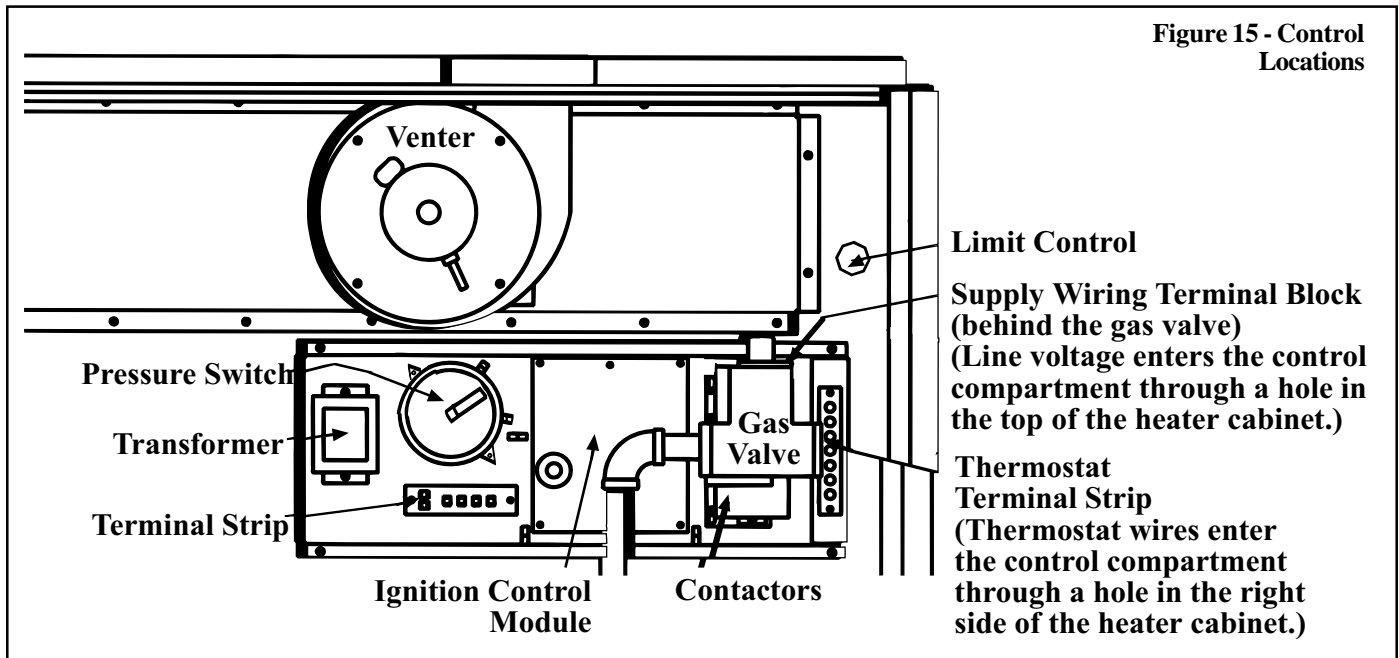

13. Combustion Air Proving Switch

The combustion air proving switch is a pressure sensitive switch that monitors air pressure to ensure that proper combustion air is available.

The switch is single pole/double throw with the normally open contacts closing when the proper airflow is sensed in the system.

On start-up when the heater is cold, the sensing pressure is at the most negative level, and as the heater and flue system warm up, the sensing pressure becomes less negative. After the system has reached equilibrium (about 20 minutes), the sensing pressure levels off.

If a restriction or excessive flue length or turns cause the sensing pressure to be outside the switch setpoint, the pressure switch will function to shut off the main burners. The main burners will remain off until the system has cooled and/or the flue system resistance is reduced. The table below lists the approximate water column negative pressure readings and switch setpoints for sea level operating conditions.

Model Size	Start-Up Cold	Equilibrium	Set Point "OFF"	Set Point "ON"
150	1.45	1.05	.75	.90
200	1.50	1.05	.75	.90
250	1.55	1.10	.75	.90
300	1.60	1.15	.75	.90
350	1.30	1.05	.75	.90
400	1.20	1.00	.75	.90

DANGER: Safe operation of this unit requires proper venting flow. NEVER bypass the combustion air proving switch or attempt to operate the unit without the venter running and the proper flow in the vent system. Hazardous conditions could result. See Hazard Levels, page 2.

14. Blower Motor and Drive

Model CAUA units are equipped with either direct drive motor(s) and blower(s) or adjustable belt-drive blower(s) and motor.

Direct Drive

All direct drive blower motors are 1 horsepower. Sizes 150-200 have a single motor. Size 150 has a 12-9 blower; Size 200 has a 12-12 blower. Sizes 250-400 have dual motors with dual 12-9 blowers.

Belt Drive

The motor horsepower on a belt drive unit is whatever was specified on the order ranging in size from 1/4 HP to 5 HP. Check the heater rating plate and the motor rating plate.

As part of the start-up procedure, check belt tension. Proper belt tension is important to the long life of the belt and motor. A loose belt will cause wear and slippage. Too much tension will cause excessive motor and blower bearing wear. Adjust the belt tension by turning the adjusting screw on the motor base until the belt can be depressed 3/4". (See Figure 16.) After correct tension is achieved, re-tighten the locknut on the adjustment screw. Be sure that the belt is aligned in the pulleys.

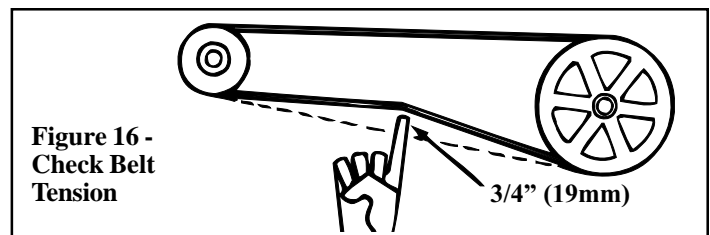

Most blower motors are equipped with thermal overload protection of the automatic, reset type. If the motor is not equipped with thermal overload protection, the unit will be equipped with a starter. The adjustable setting on the starter will be factory set to match the amp draw of the motor and sealed. No change should be made to the starter setting unless the original motor is replaced. Starters are equipped with a manual reset. If an overload condition is experienced, the condition must be corrected and the starter must be manually reset.

After the installation is complete including all ductwork, the amp draw of the motor should be checked with an amp meter to verify that the motor amp rating on the motor nameplate is not being exceeded. Amps may be adjusted downward by reducing the blower speed or by increasing the duct system static pressure. The temperature rise must be within the range specified on the unit rating plate.

14. Blower Motor and Drive (cont'd)

Adjusting Blower Speed

The blower speed may be adjusted to achieve the desired outlet temperature, as long as the adjustment is within the temperature rise and the static pressure limits shown on the heater rating plate. Direct drive motors are factory set at medium speed for heating and high speed for cooling (if ordered). Belt drive motors are factory set between maximum and minimum blower speeds.

If the duct resistance is low, the blower may deliver too high an air volume. If the resistance is very low, the blower may deliver excess air to overload the motor, causing the overload protector to activate. Reducing the blower speed will correct these conditions. If ductwork is added to an installation, it may be necessary to increase the blower speed.

Direct drive motors have multi-speed taps for speed adjustment. If your installation requires an adjustment of the blower speed, the motor may be re-wired to an alternate tap by following these instructions.

1. Turn off the gas and electric power.
2. Remove the blower door panel.
3. Consult the wiring diagram on the heater and follow the chart below to choose the wiring for the desired adjustment. Units are wired at high speed for cooling (if ordered) and medium speed for heating.

Model Sizes	Speed	Use these two motor wires:
150, 200, 250, 350	High	White and Black Medium White and Blue Low White and Red
300 and 400	High Medium	White and Black White and Blue

4. Cut the crimped cap for the end of the wire that you intend to use and strip the insulation.
5. Disconnect the factory-wired connection and re-wire, using the newly stripped wire.
6. Put a wire nut on the end of the blower motor wire that was disconnected.
7. Replace the heater door panel. Turn on the gas and electric. Check for proper operation.

Belt drives have an adjustable pulley which permits adjustment of the blower speed. Follow these instructions to adjust blower speed.

1. Turn off the gas and the electric power.
2. Loosen belt tension and remove the belt.
3. Loosen the set screw on the side of the pulley away from the motor.
4. **To increase the blower speed**, turn the adjustable half of the pulley inward. **To decrease the blower speed**, turn the adjustable half of the pulley outward. One turn of the pulley will change the speed 8-10%.
5. Tighten the set screw on the flat portion of the pulley shaft.
6. Replace the belt and adjust the belt tension. Adjust tension by turning the adjusting screw on the motor base until the belt can be depressed 3/4". (See Figure 16.) Re-tighten the lock nut on the adjusting screw. Be sure that the belts are aligned in the pulley grooves properly and are not angled from pulley to pulley.
7. Turn on the gas and electric. Light the heater following the instructions on the lighting instruction plate.
8. Check the motor amps with an amp meter. The maximum motor amp rating on the motor nameplate must not be exceeded.

When service is complete, check for proper operation.

Motor Amps

Use an amp meter to check motor amps. The chart lists full load amps for various HP's and voltages. Amps may be adjusted downward by reducing blower RPM or increasing duct system static pressure.

The chart below can be used for sizing line wiring but should not be interpreted as the exact motor amps. See the motor rating plate for exact **Form 405, Page 16**

motor specifications. At final adjustment, amperes should not exceed motor nameplate amp rating. The installation must be adjusted to obtain a temperature rise within the range specified on the heater rating plate.

Full Load Amps - Blower Motors (Open)									
HP	1/4	1/3	1/2	3/4	1	1-1/2	2	3	5
Direct-Drive Motors									
230V 1PH	--	--	--	--	6.3	--	--	--	--
Optional Belt Drive Motors									
208V 1 PH	2.1	3.2	5.1	6.3	7.5	8.3	10.0	--	--
230V 1PH	2.3	2.8	4.4	5.5	6.5	7.5	10.2	--	--
208V 3 PH	1.1	1.4	3.0	2.9	3.7	5.6	7.0	9.0	13.4
230V 3PH	1.4	1.6	2.5	2.6	3.2	5.0	6.6	8.6	13.2
460V 3PH	0.75	0.8	1.0	1.3	1.6	2.7	3.5	4.3	6.6
575V 3PH	--	--	--	--	1.1	1.6	2.1	3.6	5.4

CAUTION: An external duct system static pressure not within the limits shown on the rating plate, or improper motor pulley or belt adjustment, may overload the motor or cause the limit control to activate. See Hazard Levels, page 2.

15. Gas Valve

The main operating gas valve is powered by the 24-volt control circuit through the thermostat and safety controls. The main control valve is of the diaphragm type providing regulated gas flow preset at the factory.

WARNING: The operating valve is the prime safety shutoff. All gas supply lines must be free of dirt or scale before connecting the unit to ensure positive closure. See Hazard Levels, page 2.

16. Ignition System

This heater is equipped with a direct spark integrated control system. The system monitors the safety devices and controls the operation of the blower and venter motors and the gas valve.

Ignition System Operating Sequence

On a call for heat from the thermostat, the system energizes the venter motor and goes through a 10-second prepurge. The system verifies that the pressure switch has changed states closing the normally open contactor and that the high limit is in the closed state.

The gas valve is then energized, and the ignition system provides the high voltage spark to the electrode to ignite the main burner gas. Burner flame is electronically sensed by the control (minimum 1.0 microamps) upon carryover of all burners. (A separate solid metal probe is used as the flame sensing function. A low voltage electrical signal is imposed on the metal probe which is electrically isolated from ground. When the flame impinges on the flame sensing probe, the flame acts as a conduction path to ground. The flame rectifies and completes the DC circuit, and the ignition system acknowledges the flame.)

The blower motor is energized by the system after 30 seconds of flame sensing.

After the thermostat has been satisfied, the system de-energizes the gas valve, the venter motor goes through a 45-second post-purge, and the blower motor remains energized for an additional 135 seconds.

NOTE: This is a three trial system. The unit will lockout for one hour before initiating another trial for ignition. If the unit fails after one recycle interval, the unit will go into hard lockout and must be reset by interrupting power or resetting the thermostat. To initiate another trial for ignition before the one hour interval, either reset the thermostat or interrupt power to the unit for 30 seconds.

TYPICAL WIRING DIAGRAMS

Figure 17 - Typical Wiring Diagram for Model CAUA with Direct-Drive Blower Motor(s)

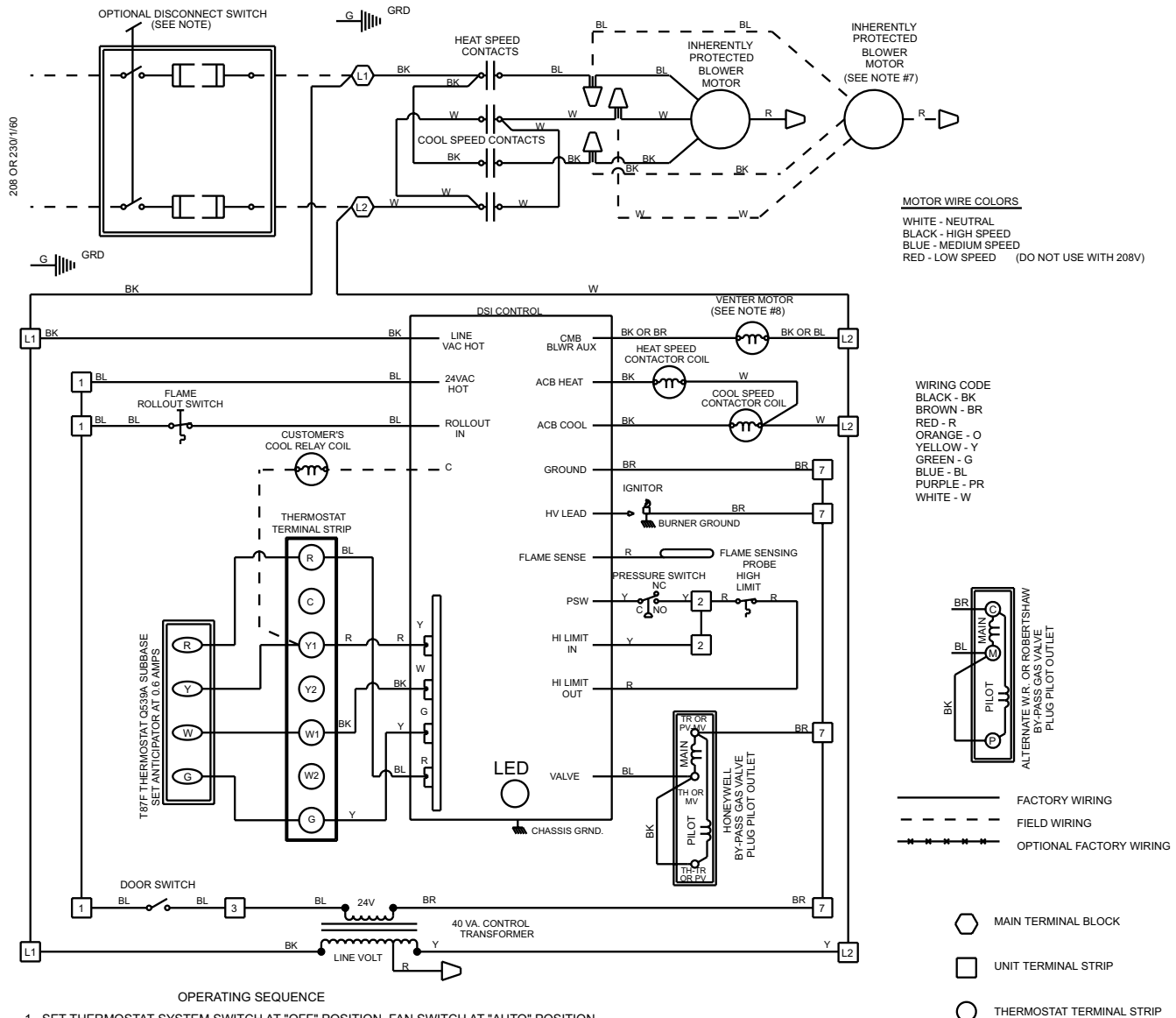

OPERATING SEQUENCE

1. SET THERMOSTAT SYSTEM SWITCH AT "OFF" POSITION, FAN SWITCH AT "AUTO" POSITION.
2. TURN ON MANUAL GAS VALVE.
3. TURN ON POWER TO UNIT.
4. SET THERMOSTAT SYSTEM SWITCH AT "HEAT" POSITION; FAN SWITCH AT "AUTO" POSITION.
5. THERMOSTAT CALLS FOR HEAT, ENERGIZING THE VENTER MOTOR.
6. VENTER PRESSURE SWITCH CLOSES, FIRING UNIT.
7. BURNER FLAME IS SENSED, AND IN 30 SECONDS THE BLOWER MOTOR IS ENERGIZED.
8. IF THE FLAME IS EXTINGUISHED DURING MAIN BURNER OPERATION, THE INTEGRATED CONTROL SYSTEM CLOSES THE MAIN VALVE AND MUST BE RESET BY INTERRUPTING POWER TO THE CONTROL CIRCUIT (SEE LIGHTING INSTRUCTIONS).
9. SET THERMOSTAT SYSTEM SWITCH AT "COOL" POSITION, FAN SWITCH AT "AUTO" POSITION.
 (A) ON A CALL FOR COOLING, BLOWER MOTOR IS ENERGIZED AT HIGH SPEED AND COOLING CIRCUIT IS ENERGIZED.
10. WHEN BLOWER DOOR IS OPENED, THE UNIT IS SHUTDOWN.
11. SET THERMOSTAT SYSTEM SWITCH AT "OFF" POSITION, FAN SWITCH AT "AUTO" POSITION, FOR SHUTDOWN..

NOTES

1. THE FOLLOWING CONTROLS ARE FIELD INSTALLED OPTIONS: THERMOSTAT
2. DOTTED WIRING AND COOL RELAY COIL INSTALLED BY OTHERS.
3. CAUTION: IF ANY OF THE ORIGINAL WIRING AS SUPPLIED WITH THE APPLIANCE MUST BE REPLACED, IT MUST BE REPLACED WITH WIRING MATERIAL HAVING A TEMPERATURE RATING OF AT LEAST 105° C. EXCEPT FOR SENSOR LEAD WIRE WHICH MUST BE 150° C.
4. USE 18 GA. WIRE FOR CONTROL WIRING ON THE UNIT.
5. USE 14 GA. WIRE FOR LINE AND MOTOR WIRING ON UNIT.
6. LINE AND FAN MOTOR BRANCH WIRE SIZES SHOULD BE OF A SIZE TO PREVENT VOLTAGE DROPS BEYOND 5% OF SUPPLY LINE VOLTAGE.
7. SECOND BLOWER MOTOR ON 250-400 UNITS ONLY.
8. VENTER MOTOR ON 350-400 UNITS HAS BROWN AND BLUE WIRES.
9. ON 208/230V. UNITS THE CONTROL TRANSFORMER HAS A DUAL VOLTAGE PRIMARY.
 FOR 230V. UNITS USE BLACK AND YELLOW LEADS (CAP RED).
 FOR 208V. UNITS USE BLACK AND RED LEADS (CAP YELLOW).
10. WHEN PROVIDING OR REPLACING FUSES IN THE FUSIBLE DISCONNECT SWITCH USE DUAL ELEMENTS TIME DELAY FUSES AND SIZE ACCORDING TO TIMES THE MAXIMUM TOTAL INPUT AMPS.

LED CODES

- SLOW FLASH NORMAL OPERATION - NO CALL FOR HEAT
- FAST FLASH NORMAL OPERATION - CALL FOR HEAT
- 2 FLASHES SYSTEM LOCKOUT - FAILED TO DETECT OR SUSTAIN FLAME
- 3 FLASHES PRESSURE SWITCH OPEN OR CLOSED
- 4 FLASHES HIGH LIMIT OPEN
- 5 FLASHES FLAME SENSED AND GAS VALVE NOT ENERGIZED
- STEADY ON INTERNAL FAILURE (MICRO-CONTROLLER FAILURE: SELF CHECK)

FIELD CONTROL WIRING

TOTAL WIRE LENGTH	DISTANCE FROM UNIT TO CONTROL	MIN. RECOMMENDED WIRE GAUGE
150'	75'	#18 GA. WIRE
250'	125'	#16 GA. WIRE
350'	175'	#14 GA. WIRE

TYPICAL WIRING DIAGRAMS (cont'd)

Figure 18 - Typical Wiring Diagram for Models CAUA with Belt-Drive Blower Motor

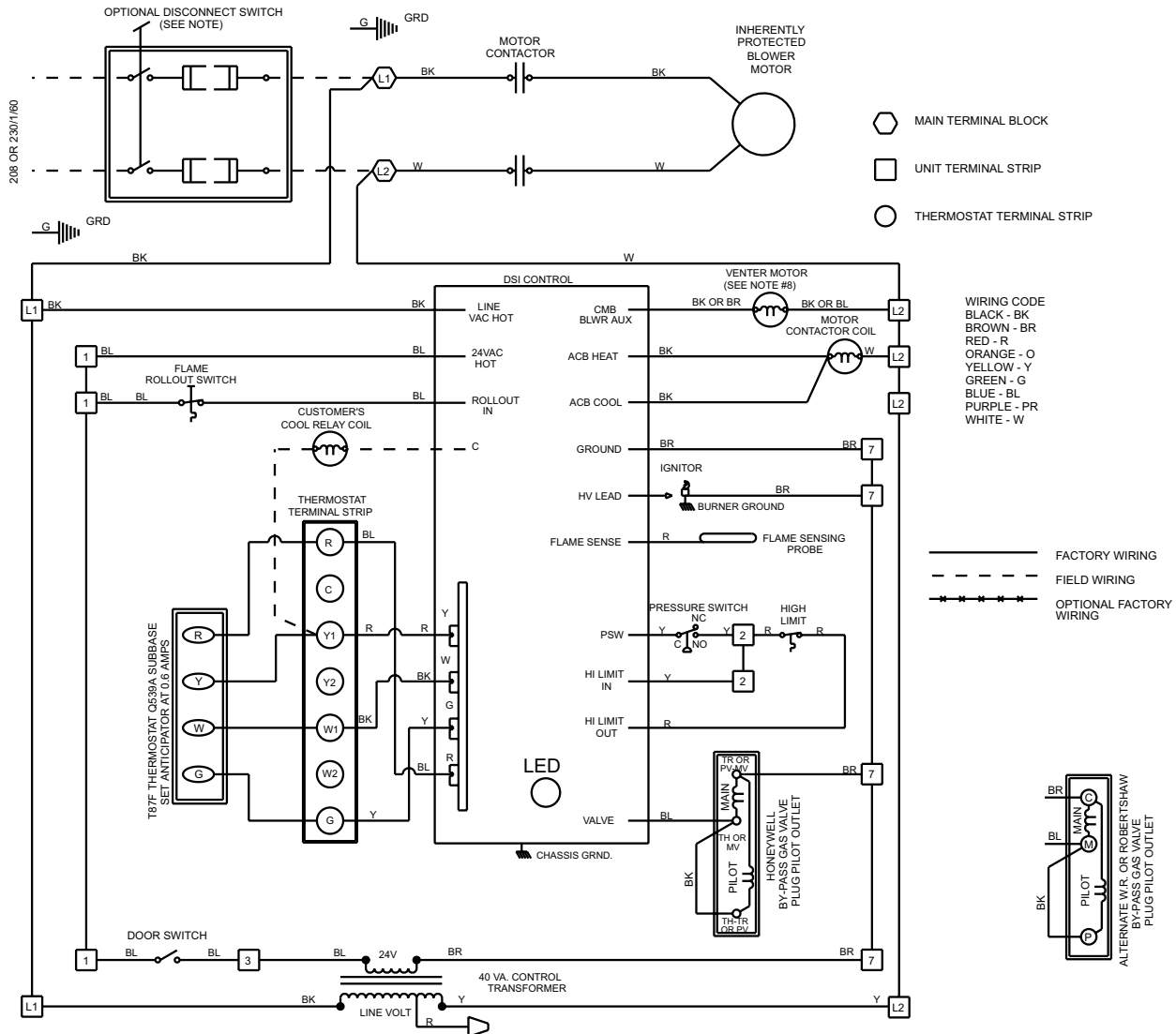

OPERATING SEQUENCE

1. SET THERMOSTAT SYSTEM SWITCH AT "OFF" POSITION; FAN SWITCH AT "AUTO" POSITION.
2. TURN ON MANUAL GAS VALVE.
3. TURN ON POWER TO UNIT.
4. SET THERMOSTAT SYSTEM SWITCH AT "HEAT" POSITION; FAN SWITCH AT "AUTO" POSITION.
5. THERMOSTAT CALLS FOR HEAT, ENERGIZING THE VENTER MOTOR.
6. VENTER PRESSURE SWITCH CLOSSES, FIRING UNIT.
7. BURNER FLAME IS SENSED, AND IN 30 SECONDS THE BLOWER MOTOR IS ENERGIZED.
8. IF THE FLAME IS EXTINGUISHED DURING MAIN BURNER OPERATION, THE INTEGRATED CONTROL SYSTEM CLOSSES THE MAIN VALVE AND MUST BE RESET BY INTERRUPTING POWER TO THE CONTROL CIRCUIT (SEE LIGHTING INSTRUCTIONS).
9. SET THERMOSTAT SYSTEM SWITCH AT "COOL" POSITION, FAN SWITCH AT "AUTO" POSITION.
(A) ON A CALL FOR COOLING, BLOWER MOTOR IS ENERGIZED AND COOLING CIRCUIT IS ENERGIZED.
10. WHEN BLOWER DOOR IS OPENED, THE UNIT IS SHUTDOWN.
11. SET THERMOSTAT SYSTEM SWITCH AT "OFF" POSITION, FAN SWITCH AT "AUTO" POSITION, FOR SHUTDOWN.

NOTES

1. THE FOLLOWING CONTROLS ARE FIELD INSTALLED OPTIONS: THERMOSTAT
2. DOTTED WIRING AND COOL RELAY COIL INSTALLED BY OTHERS.
3. CAUTION: IF ANY OF THE ORIGINAL WIRING AS SUPPLIED WITH THE APPLIANCE MUST BE REPLACED, IT MUST BE REPLACED WITH WIRING MATERIAL HAVING A TEMPERATURE RATING OF AT LEAST 105° C. EXCEPT FOR SENSOR LEAD WIRE WHICH MUST BE 150° C.
4. USE 18 GA. WIRE FOR CONTROL WIRING ON THE UNIT.
5. USE 14 GA. WIRE FOR LINE AND MOTOR WIRING ON UNIT.
6. LINE AND FAN MOTOR BRANCH WIRE SIZES SHOULD BE OF A SIZE TO PREVENT VOLTAGE DROPS BEYOND 5% OF SUPPLY LINE VOLTAGE.
7. ON 208/230V. UNITS THE CONTROL TRANSFORMER HAS A DUAL VOLTAGE PRIMARY.
FOR 230V. UNITS, USE BLACK AND YELLOW LEADS (CAP RED).
FOR 208V. UNITS, USE BLACK AND RED LEADS (CAP YELLOW).
8. VENTER MOTOR ON 350-400 UNITS HAS BROWN AND BLUE WIRES.
9. WHEN PROVIDING OR REPLACING FUSES IN THE FUSIBLE DISCONNECT SWITCH USE DUAL ELEMENTS TIME DELAY FUSES AND SIZE ACCORDING TO 1.25 TIMES THE MAXIMUM TOTAL INPUT AMPS.

FIELD CONTROL WIRING

TOTAL WIRE LENGTH	DISTANCE FROM UNIT TO CONTROL	MIN. RECOMMENDED WIRE GAUGE
150'	75'	#18 GA. WIRE
250'	125'	#16 GA. WIRE
350'	175'	#14 GA. WIRE

OPTIONAL ACCESSORIES

17. Optional Cased Cooling Coil, Model ACUA, ACUB, or ACUC

This cased cooling coil is designed for use with the Model CAUA upflow heater. It is shipped separately for field installation over the discharge opening of the heater. Before installing, verify that the coil cabinet is the same size as the heater cabinet.

Follow the installation instructions shipped with the cooling coil (Installation Form RZ 405-CC), the wiring diagram, and the instructions provided by the compressor manufacturer.

Model	ACUA			ACUB			ACUC		
Size	060	072	090	090	120	150	120	150	180
Nominal Cooling Capacity (MBH)	60	72	90	90	120	150	120	150	180
Refrigerant Type	R-22	R-22	R-22	R-22	R-22	R-22	R-22	R-22	R-22
Thermal Expansion Valves*	1	1	1	1	2	2	2	2	2
Approximate Weight (lbs)	83	86	105	110	122	140	176	180	188
No. of Intertwining Circuits	8	8	12	12	12	18	12	16	18
Face Area (sq ft)	7.79	7.79	9.38	14.04	11.67	13.70	17.13	15.38	17.13
Rows-Fins/Inch	2-10	2-12	3-10	2-12	3-10	3-12	2-12	3-10	3-10
Airflow (cfm)									
Low	1800			3000			4000		
Nominal	2400			4000			5000		
High	3000**			5000**			6000**		

* - TXV's are factory supplied. Models with two TXV's have intertwined circuiting.
 ** - Airflow in excess of maximum values shown may result in blow-off of condensation.

150	200	250	300	350	400
ACUA		ACUB		ACUC	
060		090		120	
072		120		150	
090		150		180	

Figure 19 - A Model ACU cooling coil installed on a Model CAUA heater and the line connection sizes

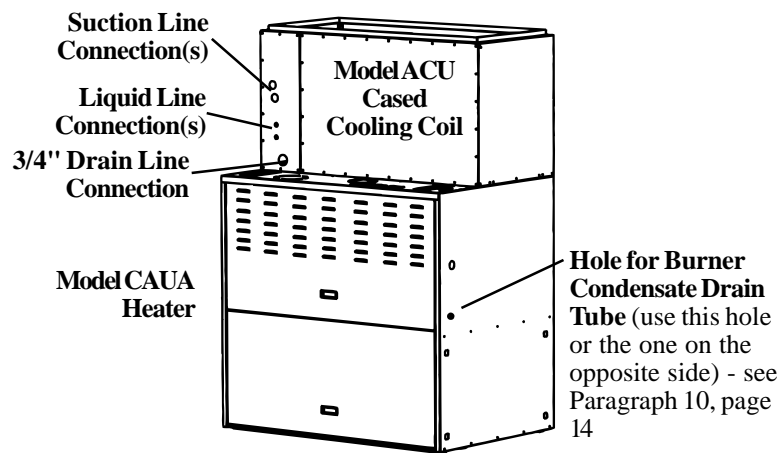

Model	Size	Connections
ACUA	060/072	(1) 7/8" Suction Line
	060	(1) 3/8" Liquid Line
	072	(1) 1/2" Liquid Line
	090	(2) 7/8" Suction Lines
ACUB	090	(2) 3/8" Liquid Lines
	090/120/150	(2) 7/8" Suction Lines
	090/120	(2) 3/8" Liquid Lines
ACUC	150	(2) 1/2" Liquid Lines
	120/150/180	(2) 7/8" Suction Lines
	120	(2) 3/8" Liquid Lines
	150/180	(2) 1/2" Liquid Lines

Drain line connection is 3/4" for all sizes.

Burner Condensate Drain

When a system includes a cooling coil, a burner condensate drain must be installed. The parts required for the drain are shipped with the heater. Instructions for installing the drain are in Paragraph 10, page 14.

Electrical Connections

Figure 20 - Typical Low Voltage Wiring (field-supplied)

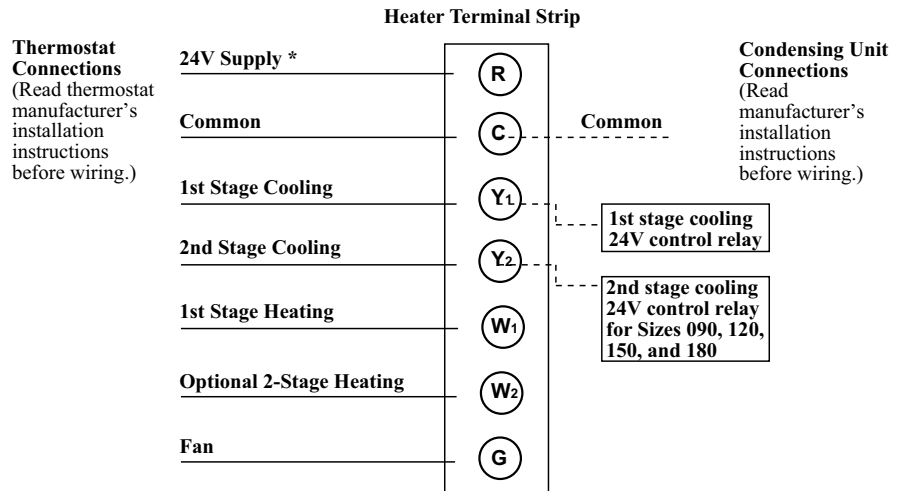

* A separate 24V control transformer may be required for the condensing equipment controls. Install a jumper wire between RH and RC terminals on the thermostat for single transformer operation. Consult the thermostat manufacturer's instructions.

Legend (field-supplied 24V wiring)

— Thermostat wiring - 24V
 - - - Field control wiring - 24V

OPTIONAL ACCESSORIES (cont'd)

18. Optional Filter Cabinet (return air only)



A filter cabinet designed for 2" pleated disposable or permanent metal filters is shipped separately for field assembly and installation. Depending on the option selected, filters are either shipped with the cabinet or are field-supplied.

To adapt to a variety of applications, the heater cabinet is designed so that the filter cabinet can attach on either the right side, the left side, or the rear of the heater. The larger filter cabinets (left two tables below) are uniquely designed so that the same cabinet can be field-assembled and installed with either a horizontal or vertical air inlet. The smaller filter cabinet in the table on the right is limited to Sizes 150 and 200 and is available with a horizontal inlet only. All cabinets have door panels for easy filter removal for changing or cleaning.

All of the filter cabinets have a duct flange for attaching the inlet air duct. For inlet duct dimensions, see Paragraph 8.

Follow the step-by-step instructions included with the filter cabinet package to assemble and attach it to the heater.

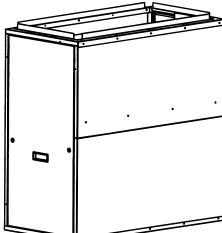
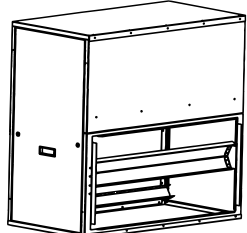
Figure 21 - Filter Cabinets with Filter Arrangements and Filter Sizes

<p>Option CW4 with 2" Pleated Filters Option CW5 with 2" Permanent Filters Option CW6 for Field-Supplied Filters</p> <ul style="list-style-type: none"> • Attaches on <i>Either Side</i> of the Heater • Vertical (Top) or Horizontal Inlet Opening • "V" Filter Rack Arrangement 	<p>Option CW7 with 2" Pleated Filters Option CW12 with 2" Permanent Filters Option CW11 for Field-Supplied Filters</p> <ul style="list-style-type: none"> • Attaches on <i>the Rear</i> of the Heater • Vertical (Top) or Horizontal Inlet Opening • "V" Filter Rack Arrangement 	<p>Option CW8 with 2" Pleated Filters Option CW9 with 2" Permanent Filters Option CW10 for Field-Supplied Filters</p> <ul style="list-style-type: none"> • Attaches on <i>either Side or the Rear</i> of a Size 150 or 200 Heater • Horizontal Inlet Opening • "V" Filter Rack Arrangement 																																																																																																																																																																																									
 <p>Figure 21A - Assembled with Vertical Air Inlet Opening</p>	 <p>Figure 21B - Assembled with Horizontal Air Inlet Opening</p>	<p>Figure 21C - Small Filter Cabinet for Sizes 150 and 200 only -- Horizontal Air Inlet Only</p> 																																																																																																																																																																																									
<table border="1" style="width: 100%; border-collapse: collapse;"> <thead> <tr> <th colspan="4">Sizes of Permanent or Pleated 2" Filters for Options CW4, CW5, or CW6</th> </tr> <tr> <th>Size</th> <th>CFM</th> <th>FPM</th> <th>Filters</th> </tr> </thead> <tbody> <tr> <td rowspan="3">150</td> <td>1800</td> <td>281</td> <td>(4) 16 x 16</td> </tr> <tr> <td>2400</td> <td>375</td> <td>(4) 16 x 16</td> </tr> <tr> <td>3000</td> <td>469</td> <td>(4) 16 x 16</td> </tr> <tr> <td rowspan="2">200</td> <td>2400</td> <td>375</td> <td>(4) 16 x 16</td> </tr> <tr> <td>3000</td> <td>469</td> <td>(4) 16 x 16</td> </tr> <tr> <td rowspan="4">250</td> <td>3000</td> <td>469</td> <td>(4) 16 x 16</td> </tr> <tr> <td>*4000</td> <td>625</td> <td>(4) 16 x 16</td> </tr> <tr> <td>**5000</td> <td>781</td> <td>(4) 16 x 16</td> </tr> <tr> <td></td> <td></td> <td>(4) 16 x 16</td> </tr> <tr> <td rowspan="4">300</td> <td>3000</td> <td>469</td> <td>(4) 16 x 16</td> </tr> <tr> <td>*4000</td> <td>625</td> <td>(4) 16 x 16</td> </tr> <tr> <td>**5000</td> <td>781</td> <td>(4) 16 x 16</td> </tr> <tr> <td></td> <td></td> <td>(4) 16 x 16</td> </tr> <tr> <td rowspan="4">350</td> <td>4300</td> <td>448</td> <td>(6) 16 x 16</td> </tr> <tr> <td>5000</td> <td>521</td> <td>(6) 16 x 16</td> </tr> <tr> <td>*6000</td> <td>625</td> <td>(6) 16 x 16</td> </tr> <tr> <td></td> <td></td> <td>(6) 16 x 16</td> </tr> <tr> <td rowspan="4">400</td> <td>4300</td> <td>448</td> <td>(6) 16 x 16</td> </tr> <tr> <td>5000</td> <td>521</td> <td>(6) 16 x 16</td> </tr> <tr> <td>*6000</td> <td>625</td> <td>(6) 16 x 16</td> </tr> <tr> <td></td> <td></td> <td>(6) 16 x 16</td> </tr> </tbody> </table>	Sizes of Permanent or Pleated 2" Filters for Options CW4, CW5, or CW6				Size	CFM	FPM	Filters	150	1800	281	(4) 16 x 16	2400	375	(4) 16 x 16	3000	469	(4) 16 x 16	200	2400	375	(4) 16 x 16	3000	469	(4) 16 x 16	250	3000	469	(4) 16 x 16	*4000	625	(4) 16 x 16	**5000	781	(4) 16 x 16			(4) 16 x 16	300	3000	469	(4) 16 x 16	*4000	625	(4) 16 x 16	**5000	781	(4) 16 x 16			(4) 16 x 16	350	4300	448	(6) 16 x 16	5000	521	(6) 16 x 16	*6000	625	(6) 16 x 16			(6) 16 x 16	400	4300	448	(6) 16 x 16	5000	521	(6) 16 x 16	*6000	625	(6) 16 x 16			(6) 16 x 16	<table border="1" style="width: 100%; border-collapse: collapse;"> <thead> <tr> <th colspan="4">Sizes of Permanent or Pleated 2" Filters for Options CW7, CW12, or CW11</th> </tr> <tr> <th>Size</th> <th>CFM</th> <th>FPM</th> <th>Filters</th> </tr> </thead> <tbody> <tr> <td rowspan="3">150</td> <td>1800</td> <td>281</td> <td>(4) 16 x 16</td> </tr> <tr> <td>2400</td> <td>375</td> <td>(4) 16 x 16</td> </tr> <tr> <td>3000</td> <td>469</td> <td>(4) 16 x 16</td> </tr> <tr> <td rowspan="2">200</td> <td>2400</td> <td>375</td> <td>(4) 16 x 16</td> </tr> <tr> <td>3000</td> <td>469</td> <td>(4) 16 x 16</td> </tr> <tr> <td rowspan="4">250</td> <td>3000</td> <td>313</td> <td>(6) 16 x 16</td> </tr> <tr> <td>4000</td> <td>417</td> <td>(6) 16 x 16</td> </tr> <tr> <td>5000</td> <td>521</td> <td>(6) 16 x 16</td> </tr> <tr> <td></td> <td></td> <td>(6) 16 x 16</td> </tr> <tr> <td rowspan="4">300</td> <td>3000</td> <td>313</td> <td>(6) 16 x 16</td> </tr> <tr> <td>4000</td> <td>417</td> <td>(6) 16 x 16</td> </tr> <tr> <td>5000</td> <td>521</td> <td>(6) 16 x 16</td> </tr> <tr> <td></td> <td></td> <td>(6) 16 x 16</td> </tr> <tr> <td rowspan="3">350</td> <td>4300</td> <td>448</td> <td>(6) 16 x 16</td> </tr> <tr> <td>5000</td> <td>521</td> <td>(6) 16 x 16</td> </tr> <tr> <td>*6000</td> <td>625</td> <td>(6) 16 x 16</td> </tr> <tr> <td rowspan="3">400</td> <td>4300</td> <td>448</td> <td>(6) 16 x 16</td> </tr> <tr> <td>5000</td> <td>521</td> <td>(6) 16 x 16</td> </tr> <tr> <td>*6000</td> <td>625</td> <td>(6) 16 x 16</td> </tr> </tbody> </table>	Sizes of Permanent or Pleated 2" Filters for Options CW7, CW12, or CW11				Size	CFM	FPM	Filters	150	1800	281	(4) 16 x 16	2400	375	(4) 16 x 16	3000	469	(4) 16 x 16	200	2400	375	(4) 16 x 16	3000	469	(4) 16 x 16	250	3000	313	(6) 16 x 16	4000	417	(6) 16 x 16	5000	521	(6) 16 x 16			(6) 16 x 16	300	3000	313	(6) 16 x 16	4000	417	(6) 16 x 16	5000	521	(6) 16 x 16			(6) 16 x 16	350	4300	448	(6) 16 x 16	5000	521	(6) 16 x 16	*6000	625	(6) 16 x 16	400	4300	448	(6) 16 x 16	5000	521	(6) 16 x 16	*6000	625	(6) 16 x 16	<table border="1" style="width: 100%; border-collapse: collapse;"> <thead> <tr> <th colspan="5">Filters for Options CW8, CW9, CW10</th> </tr> <tr> <th>Size</th> <th>CFM</th> <th>FPM</th> <th colspan="2">2" Filters</th> </tr> <tr> <th colspan="3"></th> <th>Pleated</th> <th>Permanent</th> </tr> </thead> <tbody> <tr> <td rowspan="3">150</td> <td>1800</td> <td>375</td> <td>(2) 12 x 32</td> <td>(4) 12 x 16</td> </tr> <tr> <td>2400</td> <td>500</td> <td>(2) 12 x 32</td> <td>(4) 12 x 16</td> </tr> <tr> <td>*3000</td> <td>625</td> <td>--</td> <td>(4) 12 x 16</td> </tr> <tr> <td rowspan="2">200</td> <td>2400</td> <td>500</td> <td>(2) 12 x 32</td> <td>(4) 12 x 16</td> </tr> <tr> <td>*3000</td> <td>625</td> <td>--</td> <td>(4) 12 x 16</td> </tr> </tbody> </table>	Filters for Options CW8, CW9, CW10					Size	CFM	FPM	2" Filters					Pleated	Permanent	150	1800	375	(2) 12 x 32	(4) 12 x 16	2400	500	(2) 12 x 32	(4) 12 x 16	*3000	625	--	(4) 12 x 16	200	2400	500	(2) 12 x 32	(4) 12 x 16	*3000	625	--	(4) 12 x 16
Sizes of Permanent or Pleated 2" Filters for Options CW4, CW5, or CW6																																																																																																																																																																																											
Size	CFM	FPM	Filters																																																																																																																																																																																								
150	1800	281	(4) 16 x 16																																																																																																																																																																																								
	2400	375	(4) 16 x 16																																																																																																																																																																																								
	3000	469	(4) 16 x 16																																																																																																																																																																																								
200	2400	375	(4) 16 x 16																																																																																																																																																																																								
	3000	469	(4) 16 x 16																																																																																																																																																																																								
250	3000	469	(4) 16 x 16																																																																																																																																																																																								
	*4000	625	(4) 16 x 16																																																																																																																																																																																								
	**5000	781	(4) 16 x 16																																																																																																																																																																																								
			(4) 16 x 16																																																																																																																																																																																								
300	3000	469	(4) 16 x 16																																																																																																																																																																																								
	*4000	625	(4) 16 x 16																																																																																																																																																																																								
	**5000	781	(4) 16 x 16																																																																																																																																																																																								
			(4) 16 x 16																																																																																																																																																																																								
350	4300	448	(6) 16 x 16																																																																																																																																																																																								
	5000	521	(6) 16 x 16																																																																																																																																																																																								
	*6000	625	(6) 16 x 16																																																																																																																																																																																								
			(6) 16 x 16																																																																																																																																																																																								
400	4300	448	(6) 16 x 16																																																																																																																																																																																								
	5000	521	(6) 16 x 16																																																																																																																																																																																								
	*6000	625	(6) 16 x 16																																																																																																																																																																																								
			(6) 16 x 16																																																																																																																																																																																								
Sizes of Permanent or Pleated 2" Filters for Options CW7, CW12, or CW11																																																																																																																																																																																											
Size	CFM	FPM	Filters																																																																																																																																																																																								
150	1800	281	(4) 16 x 16																																																																																																																																																																																								
	2400	375	(4) 16 x 16																																																																																																																																																																																								
	3000	469	(4) 16 x 16																																																																																																																																																																																								
200	2400	375	(4) 16 x 16																																																																																																																																																																																								
	3000	469	(4) 16 x 16																																																																																																																																																																																								
250	3000	313	(6) 16 x 16																																																																																																																																																																																								
	4000	417	(6) 16 x 16																																																																																																																																																																																								
	5000	521	(6) 16 x 16																																																																																																																																																																																								
			(6) 16 x 16																																																																																																																																																																																								
300	3000	313	(6) 16 x 16																																																																																																																																																																																								
	4000	417	(6) 16 x 16																																																																																																																																																																																								
	5000	521	(6) 16 x 16																																																																																																																																																																																								
			(6) 16 x 16																																																																																																																																																																																								
350	4300	448	(6) 16 x 16																																																																																																																																																																																								
	5000	521	(6) 16 x 16																																																																																																																																																																																								
	*6000	625	(6) 16 x 16																																																																																																																																																																																								
400	4300	448	(6) 16 x 16																																																																																																																																																																																								
	5000	521	(6) 16 x 16																																																																																																																																																																																								
	*6000	625	(6) 16 x 16																																																																																																																																																																																								
Filters for Options CW8, CW9, CW10																																																																																																																																																																																											
Size	CFM	FPM	2" Filters																																																																																																																																																																																								
			Pleated	Permanent																																																																																																																																																																																							
150	1800	375	(2) 12 x 32	(4) 12 x 16																																																																																																																																																																																							
	2400	500	(2) 12 x 32	(4) 12 x 16																																																																																																																																																																																							
	*3000	625	--	(4) 12 x 16																																																																																																																																																																																							
200	2400	500	(2) 12 x 32	(4) 12 x 16																																																																																																																																																																																							
	*3000	625	--	(4) 12 x 16																																																																																																																																																																																							
<p>NOTES:</p> <ul style="list-style-type: none"> * Requires 2" permanent filters. ** If using side inlets, two cabinets must be installed, one on each side. 																																																																																																																																																																																											

19. Mixing Cabinet (Outside and Return Air)

The optional mixing box for the Reznor® Model CAUA heater is designed to provide the system with a supply air mixture of return air and outside air. Any percentage of outside air can be supplied to the unit as long as the air temperature entering the blower is 35°F or above. The mixing box is available in an assortment of configurations with a selection of actuators and controls. All mixing boxes are completely assembled at the factory for field attachment to the rear of a Model CAUA heater.

Follow the instructions packed with the mixing box to cut out the opening and attach the mixing box. If the mixing box has dampers, follow the

instructions for routing the damper motor wires, and connect the wires according to the wiring diagram. If there are both return air and outside air dampers, follow the directions to adjust the damper linkage.

All mixing box inlet air openings have duct flanges for attachment of ductwork. Ductwork must be attached to the outside air opening. Removable door panels provide for filter access from either end of the cabinet. If the box was ordered with optional filters, it is shipped with the filters installed.

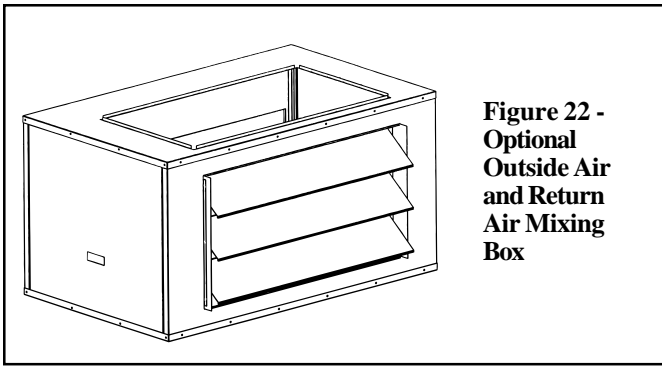

**Figure 22 -
Optional
Outside Air
and Return
Air Mixing
Box**

Configurations/Accessories

Before installing, check to be sure that the configuration of the mixing box matches the order and that any accessories ordered are part of the cabinet. Factory-installed optional accessories could include a damper motor, potentiometer, return air controller, mixed air controller, and/or filters. NOTE: If the potentiometer is to be field-installed, it is shipped in a separate carton.

Option Configuration

GA1	Top Outside Air Opening <i>with</i> Dampers/ Rear or Bottom Return Air Opening <i>without</i> Dampers
GA2	Rear Outside Air Opening <i>with</i> Dampers/ Top or Bottom Return Air Opening <i>without</i> Dampers
GA3	Bottom Outside Air Opening <i>with</i> Dampers/ Top or Rear Return Air Opening <i>without</i> Dampers
GA4	Bottom Outside Air Opening <i>with</i> Dampers/ Rear Return Air Opening <i>with</i> Dampers
GA5	Bottom Outside Air Opening <i>with</i> Dampers/ Top Return Air Opening <i>with</i> Dampers
GA6	Rear Outside Air Opening <i>with</i> Dampers/ Top Return Air Opening <i>with</i> Dampers
GA7	Rear Outside Air Opening <i>with</i> Dampers/ Bottom Return Air Opening <i>with</i> Dampers
GA8	Top Outside Air Opening <i>with</i> Dampers/ Rear Return Air Opening <i>with</i> Dampers
GA9	Top Outside Air Opening <i>with</i> Dampers/ Bottom Return Air Opening <i>with</i> Dampers

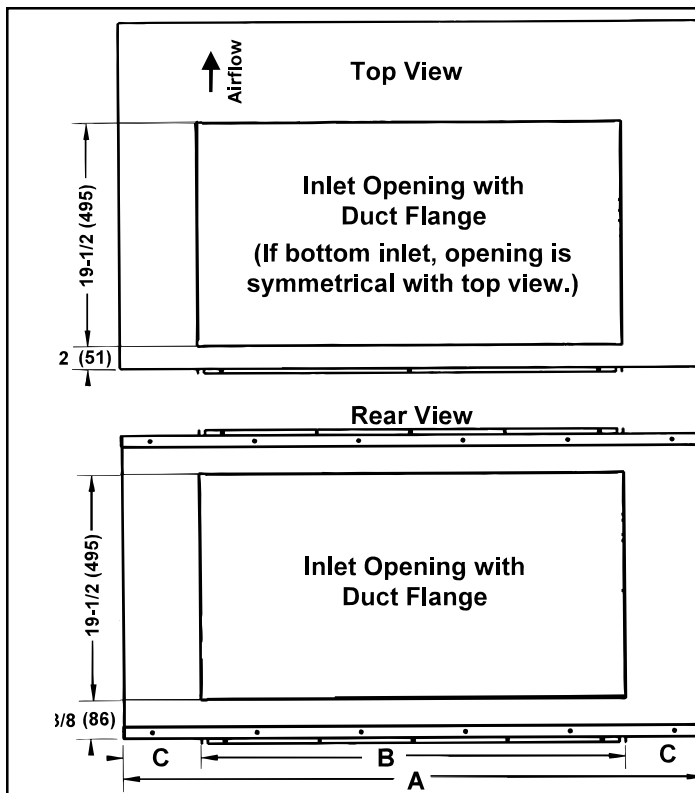

**Figure 23 - Dimensions of Optional
Mixing Box - inches (mm)**

	150-200	250-400
A	38 (965)	50 (1270)
B	22-3/4 (578)	36-1/2 (927)
C	7-5/8 (194)	6-3/4 (171)

Note: Damper frame fits in the inlet opening.

20. Discharge Plenum (Sizes 350 and 400 only)

The optional discharge plenum is designed to be used with a screened mounting base (Paragraph 21) to create a "packaged stand-alone" upflow system that circulates building air. However, the discharge plenum may also be used in place of ductwork in applications that do not have an optional mounting base.

The discharge plenum is available in three types. Option CD60 and CD61 are for a heater without a cooling coil; Option CD60 is designed for an open area and Option CD61 includes field-installed blockoff plates to block off one or two sides. Option CD62 can only be ordered with a cooling coil and includes blockoff plates to provide higher velocity required for cooling.

A discharge plenum adds 49-15/16" (1268mm) to the height of the heater. (If installing Option CD62, this height includes the cooling coil.)

21. Inlet Base (Sizes 350 and 400 only)

The optional mounting base is designed to support a Model CAUA 350 or 400 heater while providing an inlet for return air. The mounting base is designed to be used with an optional discharge plenum (Paragraph 20) creating a "packaged stand-alone" heating or heating/cooling upflow system which can be used in an air turnover application.

However, if the installation requires it, the mounting base may also be used with discharge ductwork.

The mounting base has guarded openings on all four sides and is available with optional 1" flat disposable, 1" permanent aluminum, or 1" pleated disposable filters.

The base is designed for a fairly open area and must have at least three of the four sides open.

The base adds 36-1/2" (927mm) to the overall height.

Check/Test/Start-Up

22. Check Installation & Start-Up

Check the installation prior to start-up:

- Check clearances from combustibles. Requirements are shown in Paragraph 4.
- If installed as a separated-combustion unit, check vent/combustion air system to be sure that it is installed according to the instructions in Paragraph 7A.
- Check piping for leaks and proper gas line pressure. Bleed gas lines of trapped air. See Paragraph 9.
- Check the blower compartment to be sure that all shipping supports have been removed. Close the blower compartment door securely. Heater will not operate if the blower compartment door is not closed.
- Check electrical wiring. Be sure all wire gauges are as recommended. A service disconnect switch should be used. Verify that fusing or circuit breakers are adequate for the load use.

Start-Up

WARNINGS: For your safety, read before operating. If you do not follow these instructions exactly, a fire or explosion may result causing property damage, personal injury, or loss of life.

- This appliance does not have a pilot. It is equipped with an ignition device which automatically lights the burner. Do not try to light the burner by hand.
- Before operating, smell all around the appliance area for gas. Be sure to smell next to the floor because some gas is heavier than air and will settle on the floor.

WHAT TO DO IF YOU SMELL GAS

- Do not try to light any appliance.
 - Do not touch any electrical switch; do not use any phone in your building.
 - Immediately call your gas supplier from a neighbor's phone. Follow the gas supplier's instructions.
 - If you cannot reach your gas supplier, call your fire department.
-
- Use only your hand to turn the gas control ON/OFF knob on the gas valve. Never use tools. If the valve ON/OFF knob will not turn by hand, do not try to repair it. Call a qualified service technician. Force or attempted repair may result in a fire or explosion.
 - Do not use this appliance if any part has been under water. Immediately call a qualified service technician to inspect the appliance and to

replace any part of the control system and any gas control which has been under water.

Operating Instructions and Operating Sequence

1. Set thermostat at lowest setting.
2. Turn off all electric power to the appliance.
3. This appliance is equipped with an ignition device which automatically lights the burner. Do not try to light the burner by hand. Open the access door and locate the gas valve.
4. **Models CAUA 150 and 200** - Locate the gas control (ON/OFF) knob on the gas valve. Turn the gas control knob clockwise to "OFF".

Models CAUA 250, 300, 350, and 400 - Locate the gas control (ON/OFF) knob on the gas valve. Turn knob clockwise to align the line on the knob with the position indicator. Depress knob and continue rotation to the "OFF" position.

Top View of Gas Valve used on CAUA 150 and 200

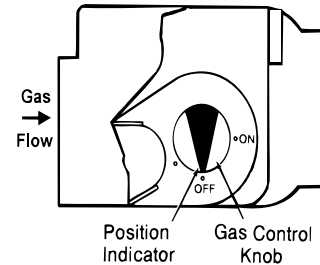

Control Knob on Top of Gas Valve used on CAUA 250 - 400

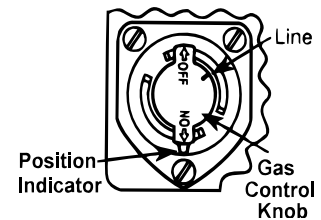

5. Wait five (5) minutes to clear out any gas. Then smell for gas, including near the floor. **If you smell gas, STOP!** and follow the steps in the **WARNINGS** printed in the right column or on the Operating Label on the heater. If you do not smell gas, proceed to the next step.
6. **Models CAUA 150 and 200** - Turn the gas control knob counterclockwise to "ON".
Models CAUA 250, 300, 350, and 400 - Turn knob counterclockwise to align the line on the knob with the position indicator. Allow knob to "pop up", and continue rotation to the "ON" position.
7. Close the access door.
8. Turn on the electric power to the heater.
9. Set the thermostat to the desired setting.

NOTE: If the appliance does not operate, follow the instructions "To Turn Off Gas to the Appliance" printed below (and on the Operating Label on the heater). Call your service technician.

10. Thermostat calls for heat, energizing the venter motor.
11. Venter pressure switch closes, allowing the unit to fire.
12. Burner flame is sensed and in 30 seconds, the blower motor is energized.
13. If the flame is extinguished during the main burner operation, the integrated control system closes the main valve and must be reset by interrupting power to the control circuit. (See lighting instructions on the heater.)

TO TURN OFF GAS TO THE APPLIANCE

- 1) Set thermostat to lowest setting
- 2) If service is to be performed, turn off all electric power to the appliance.
- 3) Open the access door.
- 4) Turn the gas control knob to "OFF" (follow instructions in No. 4 above). Do not force control knob.
- 5) Close the access door.

Check installation after start-up:

- Vent System Testing Procedure - Power Vent Units (does not apply to separated-combustion installation)**
 1. Seal any unused openings in the venting system.
 2. Inspect the venting system for proper size and horizontal pitch, as required in the National Fuel Gas Code, ANSI Z223.1 or CAN/CGA B149.1 and B149.2, Installation Code for Gas Burning Appliances and Equipment, and this manual. Determine that there is no blockage or restriction, leakage, corrosion and other deficiencies which could cause an unsafe condition.
 3. In so far as practical, close all building doors and windows and all doors between the space where the heater is and other spaces of the building. Turn on clothes dryers and exhaust fans, such as range hoods and bathroom exhausts, so they shall operate at maximum speed. Do not operate a summer exhaust fan. Close fireplace dampers.
 4. Light the heater following the lighting instructions. Adjust the thermostat for continued operation. Verify that combustion products are venting properly. After determining that the heater vents properly, return doors, windows, exhaust fans, and fireplace dampers to their previous conditions. If improper venting is observed, the venting system must be corrected.
- With the unit in operation, measure manifold gas pressure. Manifold pressure for natural gas should be 3.5" w.c. and 10" w.c. for propane gas. See Paragraph 9.
- Turn the unit off and on, pausing two minutes between each cycle. Observe for smooth ignition.
- Place the "Owner's Envelope" containing the Limited Warranty, this booklet, the operation/maintenance/service manual, and any control or optional information in an accessible location near the heater. Follow the instructions on the envelope.

DANGER: The gas burner in this gas-fired equipment is designed and equipped to provide safe and economically controlled complete combustion. However, if the installation does not permit the burner to receive the proper supply of combustion air, complete combustion may not occur. The result is incomplete combustion which produces carbon monoxide, a poisonous gas that can cause death. Safe operation of indirect-fired gas burning equipment requires a properly operating vent system which vents all flue products to the outside atmosphere. FAILURE TO PROVIDE PROPER VENTING WILL RESULT IN A HEALTH HAZARD WHICH COULD CAUSE SERIOUS PERSONAL INJURY OR DEATH.

If installed as a separated-combustion unit, install either the horizontal or vertical combustion air/vent system illustrated in Paragraph 7A using the concentric adapter supplied. Always comply with the combustion air requirements in the installation codes and instructions. Combustion air at the burner should be regulated only by manufacturer-provided equipment. NEVER RESTRICT OR OTHERWISE ALTER THE SUPPLY OF COMBUSTION AIR TO ANY HEATER. CHECK THE VENT SYSTEM FOR SOUNDNESS AND FUNCTION; MAINTAIN IT IN PROPER OPERATING CONDITION.

Thomas & Betts



©2001 Thomas & Betts Corporation, All rights reserved. Printed in the U.S.A.
MANUFACTURER OF HEATING, COOLING, AND VENTILATING SYSTEMS

Trademark Note: Reznor® is registered in the United States and other countries.

(800) 695-1901; www.ReznorOnLine.com

2/01 YL Form RZ 405 (Version B)

Free Manuals Download Website

<http://myh66.com>

<http://usermanuals.us>

<http://www.somanuals.com>

<http://www.4manuals.cc>

<http://www.manual-lib.com>

<http://www.404manual.com>

<http://www.luxmanual.com>

<http://aubethermostatmanual.com>

Golf course search by state

<http://golfingnear.com>

Email search by domain

<http://emailbydomain.com>

Auto manuals search

<http://auto.somanuals.com>

TV manuals search

<http://tv.somanuals.com>