

Thule System Kit 018

CHRYSLER GS Turbo 2
CHRYSLER Laser
DODGE Daytona

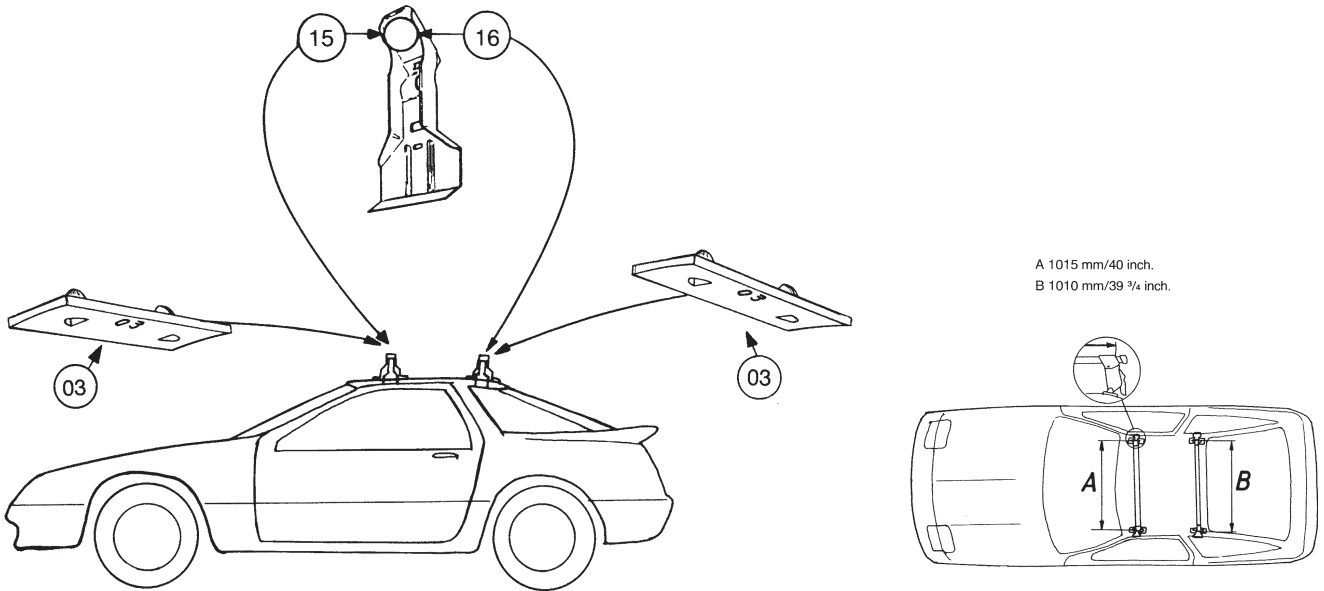
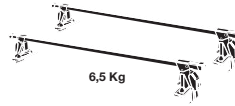

002*4EF/501-0018-02

Thule System Kit 019

PONTIAC Firebird
BUICK Reatta, 88-

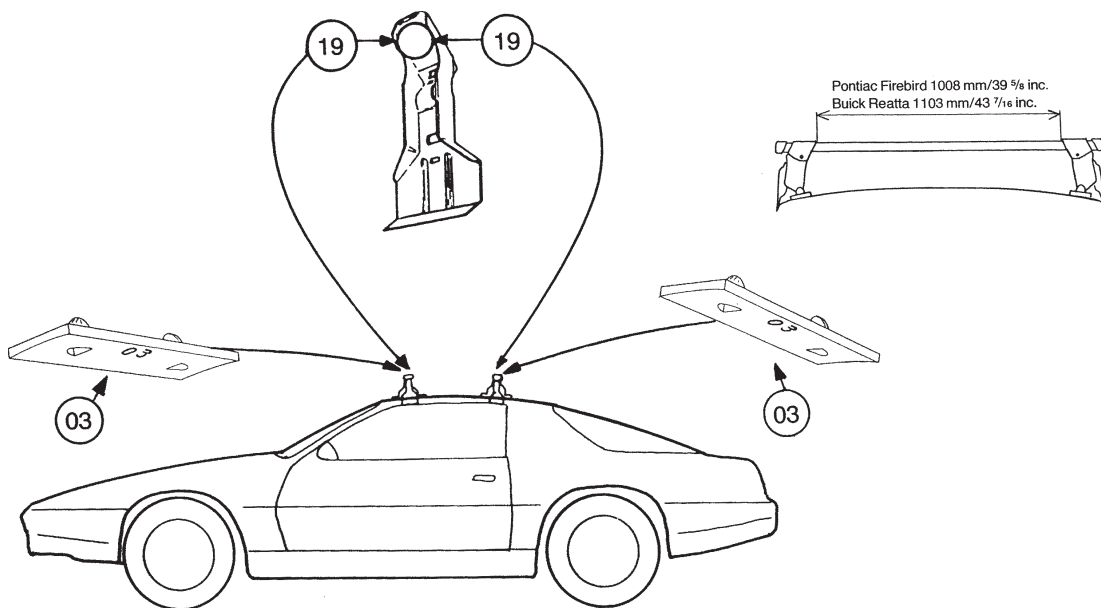
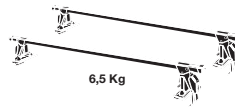

909*4EF/501-0019

Free Manuals Download Website

<http://myh66.com>

<http://usermanuals.us>

<http://www.somanuals.com>

<http://www.4manuals.cc>

<http://www.manual-lib.com>

<http://www.404manual.com>

<http://www.luxmanual.com>

<http://aubethermostatmanual.com>

Golf course search by state

<http://golfingnear.com>

Email search by domain

<http://emailbydomain.com>

Auto manuals search

<http://auto.somanuals.com>

TV manuals search

<http://tv.somanuals.com>