

# TIMEX®

Model T105

## **Color Changing Alarm Clock**

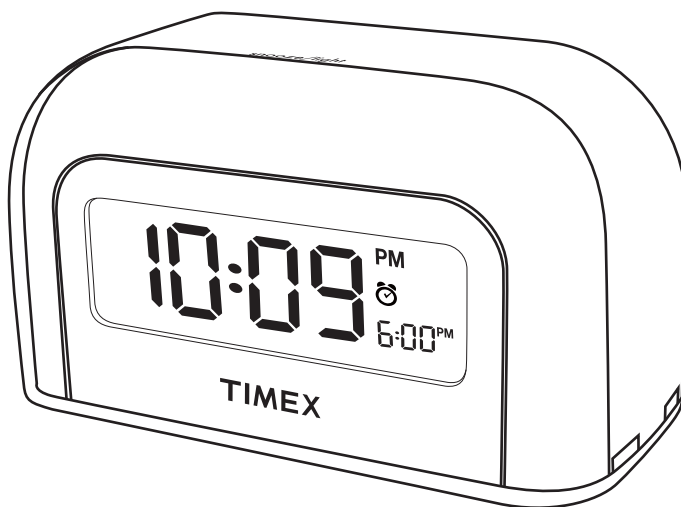

**For additional information, online  
registration, and exclusive special  
offers please visit our website:**

[www.timexaudio.com](http://www.timexaudio.com)

# Table of Contents

---

<b>Controls and Indicators</b> .....	2
<b>Display</b> .....	2
<b>Quick start</b> .....	3
<b>Getting started</b> .....	4
<b>Setting Clock Time and Alarm Time</b> .....	5
<b>Using the Alarm</b> .....	6
<b>Snooze Operation</b> .....	6
<b>Color Change</b> .....	6
<b>A Consumer Guide to Product Safety</b> .....	7
<b>Limited 90-Day Warranty Information</b> .....	8

---

## A Consumer Guide to Product Safety

---

**IMPORTANT SAFETY INFORMATION: IT IS THE USER'S RESPONSIBILITY TO USE THIS PRODUCT PRUDENTLY, RESPONSIBLY AND IN A SAFE, NON-DISTRACTED MANNER AT ALL TIMES. FAILURE BY THE USER TO PAY FULL ATTENTION TO THE PROPER OPERATION OF ANY EQUIPMENT BEING USED ALONG WITH THIS PRODUCT COULD RESULT IN AN ACCIDENT AND/OR PERSONAL INJURY.**

### Maintenance

- Place the unit on a level surface away from sources of direct sunlight or excessive heat.
- Protect your furniture when placing your unit on a natural wood and lacquered finish. A cloth or other protective material should be placed between it and the furniture.
- Clean your unit with a soft cloth moistened only with mild soap and water. Stronger cleaning agents, such as Benzine, thinner or similar materials can damage the surface of the unit.

# Controls and Indicators

## Back of Clock

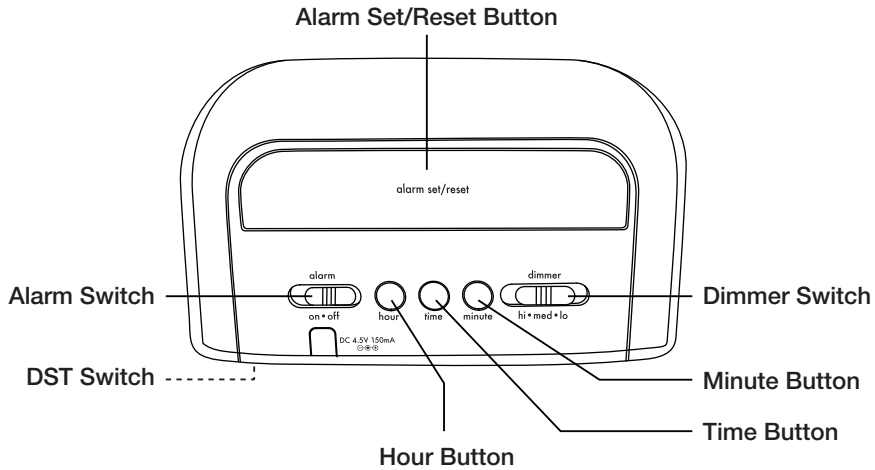

## Bottom of Clock

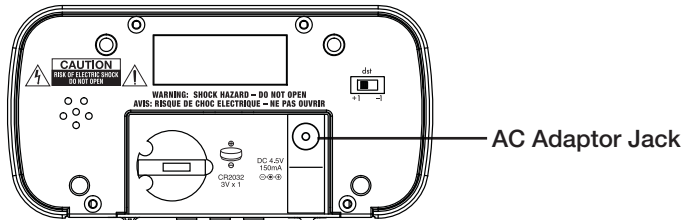

## Display



# Quick start

## 1: power

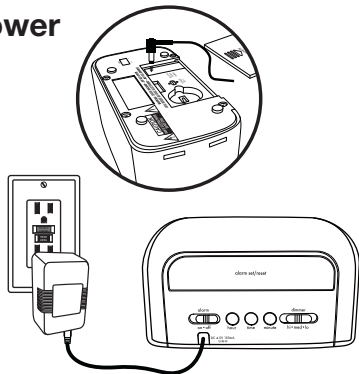

Slide open the battery compartment on the bottom of the unit. Attach AC adaptor cable inside battery compartment on the bottom of T105 and plug the other end into a wall socket.

## 2: clock battery backup

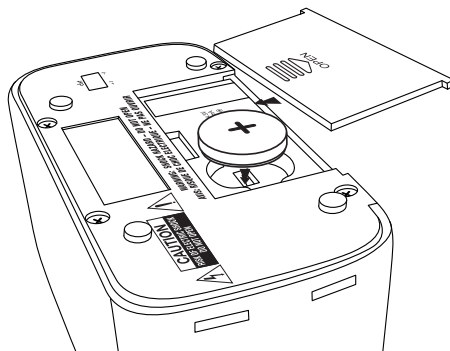

Insert 1 "CR2032" battery as indicated into battery compartment. Replace battery compartment cover.

## 3: clock setting

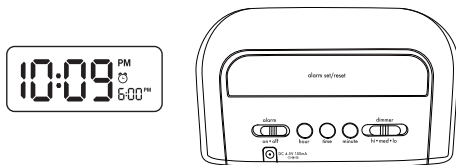

Press and hold the **Time Button** on the back of the T105 until the time display flashes. Press the **Hour Button** to advance the hour (a PM indicator appears for PM setting; there is no AM indicator), then press the **Minute Button** to advance the minutes. When the correct time is set, press the **Time Button**. Two beeps will confirm clock setting is complete.

## 4: alarm setting

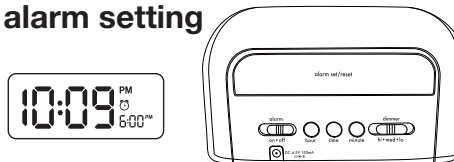

Press and hold the **Alarm Set/Reset Button** on the back of the T105 until the alarm time display flashes. Press the **Hour Button** to advance the hour (a PM indicator appears for PM setting; there is no AM indicator), then press the **Minute Button** to advance the minutes. When the correct alarm time is set, press the **Alarm Set Button**. Two beeps will confirm alarm setting is complete. Move the **Alarm Switch** on the back of the unit to the ON position to arm the alarm. The alarm indicator will appear.

# Getting Started

## Installing the Backup Battery

If the Backup Battery has been installed and a power failure occurs or the AC cord is accidentally disconnected, the current time and alarm time settings will be temporarily maintained.

If the Backup Battery has not been installed or is dead, when the AC power resumes the display will show 12:00 and you must reset the time and alarm settings.

1. Open the battery compartment cover located on the bottom of the unit.
2. Install a CR2032 battery.
3. Close the battery cover.

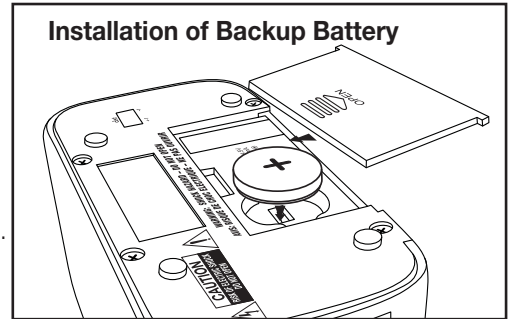

## AC adaptor

The unit comes with an AC adaptor that must be used to power the unit (do not try to run on back up battery).

Plug the cable into the DC jack located inside battery compartment on the bottom of unit and plug the other end into AC wall outlet.

## Maintenance

Protect your furniture when placing the clock on natural wood or a lacquered wood finish. A cloth or other protective material should be placed between the unit and the furniture.

Clean the casing with a soft cloth moistened only with mild soap and water. Stronger cleaning agents may damage the surface of the case.

# Setting Clock Time and Alarm Time

---

## Setting Clock Time

1. Press and hold the **Time Button** until the time display flashes. (If no time-set buttons are pressed within a few seconds, the display will stop flashing and return to normal mode).
2. Press the **Hour Button** to advance the hour (a **PM Indicator** is on the upper right of the display; there is no AM indicator), then press the **Minute Button** to advance the minutes to the correct time. **Note:** hold the hour or minute button to advance clock rapidly.
3. Press the **Time Button** when the correct time is displayed. Two beeps will confirm that clock setting is complete.

**NOTE:** This unit comes with a **Daylight Savings Time (DST) Switch** (located on the bottom of the unit) to make adjusting for Daylight Saving Time simple. Just move the **DST Switch** to +1 to add an hour or to -1 to subtract an hour from the current time. When the DST switch is set to +1, a DST Icon will appear on the upper right of the display.

## Setting Alarm Time

1. Press and hold the **Alarm Set/Reset Button** until the alarm time display located at the lower right of the display flashes. (If no alarm-set buttons are pressed within a few seconds, the display will stop flashing and return to normal mode).
2. As above, press the **Hour Button** and **Minute Button** to set the desired alarm time (press and hold hour or minute button to advance display rapidly). As with clock setting, the PM Indicator appears at the top of the alarm time display; there is no AM indicator.
4. When the desired alarm time is displayed, press the **Alarm Set/Reset Button** again to return normal mode. Two beeps will indicate Alarm Setting is complete.

## Using the Alarm

---

1. After setting the alarm time, set the **Alarm Switch** located on the back of the unit to ON to turn on the alarm. The Alarm Indicator Icon will appear on the display, showing that the alarm will sound at the time displayed.
2. After the alarm sounds, press the **Alarm Set/Reset Button** to turn off the buzzer and automatically reset the alarm for the same time the following day.
3. To turn off the alarm without setting it for the following day, switch the **Alarm Switch** to OFF. The Alarm Indicator Icon will disappear.

NOTE: The alarm will sound for approximately 1 hour and then turn off automatically. This cycle will repeat every 24 hours unless the controls are changed.

## Snooze Operation

---

1. Press down anywhere on top of the clock cabinet after the alarm sounds to temporarily shut off the alarm, allowing you to snooze for nine minutes before the alarm sounds again. You may repeat this several times during the one-hour alarm cycle.

## Color Change

---

1. During normal mode, press anywhere on top of the clock cabinet to change the color of cabinet and display backlight. Each time you press, the light color changes (there are 7 colors).
2. You can control the backlight brightness by setting the Dimmer Switch to Hi, Med or Lo.

# IMPORTANT SAFETY INSTRUCTIONS

This unit has been designed and manufactured to assure your personal safety. Improper use can result in potential electrical shock or fire hazards. Please read all the safety and operating instructions carefully before installation and use. Keep these instructions handy for future reference. Take special note, adhere to all warning, and always follow the instructions on the unit and in the instruction and service manuals.

1. **Water and Moisture** – The unit should not be used near water. For example: near a bathtub, washbowl, kitchen sink, laundry tub, swimming pool or in a wet basement.
2. **Ventilation** – The unit should be situated so that its location or position does not interfere with its proper ventilation. For example, it should not be situated on a bed, sofa, rug or similar surface that may block ventilation openings. Also, it should not be placed in a built-in installation, such as a bookcase or cabinet that may impede the flow of air through the ventilation openings.
3. **Heat** – The unit should be situated away from heat sources such as radiators, heat registers, stoves or other appliances (including amplifiers) that produce heat.
4. **Power Sources** – The unit should be connected to a power supply only of the type described in the operating instructions or as marked on the appliance itself.
5. **Power-cord Protection** – Power supply cords should be routed so that they are not likely to be walked on or pinched by items placed upon or against them. It is always best to have a clear area from where the cord exits the unit to where it is plugged into an AC outlet.
6. **Cleaning** – Unplug this product from the wall outlet before cleaning. Do not use liquid cleaners or aerosol cleaners. Use a damp cloth for cleaning.
7. **Non-Use Periods** – The power cord of the unit should be unplugged from the outlet when it is to be left unused for a long period of time.
8. **Object and Liquid Entry** – Care should be taken so that objects do not fall and liquids are not spilled into an enclosure through openings.
9. **Attachments** – Do not use attachments not recommended by the product manufacturer as they may cause hazards.
10. **Lightning** – For added protection for this product during a lightning storm, or when it is left unattended and unused for long periods of time, unplug it from the wall outlet and disconnect the antenna or cable system. This will prevent damage to the product due to lightning and power-line surges.
11. **Overloading** – Do not overload wall outlets, extension cords, or integral convenience receptacles as this can result in a risk of fire or electric shock.
12. **Damage Require Service** – The unit should be serviced by qualified service personnel when:
  - A. The power supply cord or plug has been damaged.
  - B. Objects have fallen into or liquid has been spilled into the enclosure.
  - C. The unit has been exposed to rain.
  - D. The unit has been dropped or the enclosure damaged.
  - E. The unit does not appear to operate normally or exhibits a marked change in performance.
13. **Service** – The user should not attempt to service the unit beyond that described in the user's operating instructions. All other servicing should be referred to qualified service personnel.
14. **Safety Check** – Upon completion of any service or repairs to this product, ask the service technician to perform safety checks to determine that the product is in proper operating condition.

**For questions or comments regarding this or other products, please call our toll-free number 1-800-888-4491.**



## Limited 90-Day Warranty Information

---

Timex Audio Products, a division of SDI Technologies Inc. (hereafter referred to as SDI Technologies), warrants this product to be free from defects in workmanship and materials, under normal use and conditions, for a period of 90 days from the date of original purchase.

Should service be required by reason of any defect or malfunction during the warranty period, SDI Technologies will repair or, at its discretion, replace this product without charge (except for a \$10.00 charge for handling, packing, return UPS/postage, and insurance). This decision is subject to verification of the defect or malfunction upon delivery of this product to the Factory Service Center listed below. The product must include proof of purchase, including date of purchase. The fee for service after the warranty period or without proof of purchase is \$30.00.

Before returning this product for service, please first replace the batteries (if applicable) with fresh ones, as exhausted or defective batteries are the most common cause of problems encountered.

If service is still required:

1. Remove batteries (if applicable) and pack the unit in a well-padded, heavy corrugated box.
2. Enclose a photocopy of your sales receipt, credit card statement, or other proof of the date of purchase.
3. Enclose a check or money order payable to the order of SDI Technologies, Inc. for the sum of \$10.00 (or \$30.00 if after the warranty period or without proof of purchase).
4. Send the unit prepaid to the Factory Service Center listed below:

### **Consumer Repair Department**

SDI Technologies Inc.

Timex Audio Products Division

1330 Goodyear Drive

El Paso TX 79936-6420

**NOTE:** This warranty is valid only if the product is used for the purpose for which it was designed. It does not cover (i) products which have been damaged by negligence, misuse or accident, or which have been modified or repaired by unauthorized persons; (ii) cracked or broken cabinets, or units damaged by excessive heat; (iii) damage to tape cassettes (if applicable); (iv) the cost of shipping this product to the Factory Service Center and its return to the owner.

This warranty is valid only in the United States of America and does not extend to owners of the product subsequent to the original purchaser. Any applicable implied warranties are also limited to 90 days, and SDI Technologies will not be liable for consequential damages. (Some states do not allow limitations on implied warranties or exclusion of consequential damages, so these restrictions may not apply to you.) This warranty gives you specific legal rights, and you may also have other rights which vary from state to state.

**© 2008 SDI Technologies, Inc. All rights reserved**

**TIMEX is a registered trademark of Timex Corporation the United States and other countries**

## Free Manuals Download Website

<http://myh66.com>

<http://usermanuals.us>

<http://www.somanuals.com>

<http://www.4manuals.cc>

<http://www.manual-lib.com>

<http://www.404manual.com>

<http://www.luxmanual.com>

<http://aubethermostatmanual.com>

Golf course search by state

<http://golfingnear.com>

Email search by domain

<http://emailbydomain.com>

Auto manuals search

<http://auto.somanuals.com>

TV manuals search

<http://tv.somanuals.com>