

**NEW 900 SERIES
IN-WALL MIXER POWER AMPLIFIER**

**W-906A
W-912A**

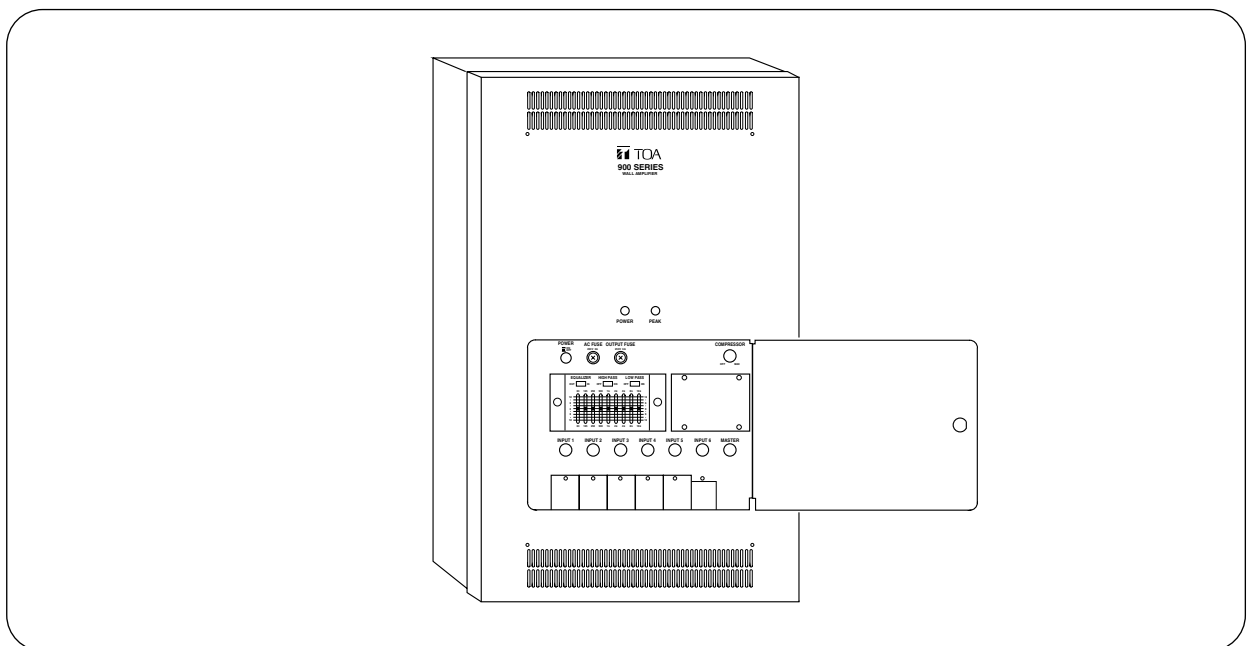

TABLE OF CONTENTS

1. GENERAL DESCRIPTION	2	6. OPERATION	8
2. FEATURES	2	7. HOW TO USE VOLUME CONTROL COVER	9
3. NOMENCLATURE AND FUNCTIONS		8. OUTPUT EQ CHARACTERISTIC	10
Front	3	9. BLOCK DIAGRAM	10
Front (viewed with the front cover removed)	4	10. SPECIFICATIONS	11
4. INSTALLATION AND CONNECTION	5	Accessories	12
5. SERVICING	8		

Please follow the instructions in this manual to obtain the optimum results from this unit.
We also recommend that you keep this manual handy for future reference.

1. GENERAL DESCRIPTION

The TOA W-906A and W-912A Mixer Power Amplifiers control and mix up to six independent input signals plus two inputs with use of expanding kit. The W-906A delivers up to 60 W of output power and the W-912A 120 W. Optional accessory modules are available for use with the W-906A and W-912A to provide versatility for a wide range of operating applications. Edge connectors at the bottom of the front panel permit the selection of the TOA plug-in modules: The H-01 series, H-02 series, H-03 series, H-21 and H-22 Microphone Preamplifiers, the E-01 series and E-11 series Mag. Phono Preamplifiers, the X-01 series, X-11 series and X-21 Auxiliary Preamplifiers for high-level sources, the B-01 series and B-11 series Bridging Transformers for bridging high-impedance lines, the L-01 series Line Matching Transformers for matching 600 Ω lines, I-01 Paging Input for combining with TOA Intercom Systems EXES-1000, EXES-5000 and EX-16, T-01 series Line Outputs for matching 600 Ω lines and the S-01, S-02 and S-03 Tone Signal Generators for generating attention-getting signals and 1 kHz sine wave for testing within the total system. Other features include a muting function. Sources fed to particular input module accessories are muted by short-circuiting at MUTE TERMINALS on the front. To perform this function, Module E-11, X-11 series or B-11 series is required. Using any of the modules H-21, H-22 and X-21 permits the input signal level to be controlled remotely by means of an external potentiometer.

The W-906A and W-912A have a built-in one-octave graphic equalizer with 9 bands to tailor sound system frequency response to room acoustics, reducing feed-back tendencies and improving intelligibility. A built-in compressor circuit is provided to protect the output level from distortion as a result of excessive input and keeps it constant. Compressor's threshold level can be adjusted.

The W-906A and W-912A Mixer Power Amplifiers have output terminals to match 4 or 8 Ω speaker systems, or speaker distribution system may be connected to the 25 or 70 V terminals. User's (blank) space is provided for additional functions to be made by the customers. The expanding kit (optional) may be loaded in this space when the number of input is increased. Protection against tampering is assured by means of a key-locked hinged door. The W-906A and W-912A can be mounted in any four-inch wall with of the BX-9F Flush Mounting Black Box. On-wall mounting is also possible with the BX-9S Surface Mounting Box.

2. FEATURES

- 6-channel mixer power amplifier
- Expandable to 8-input
- Output power: 120 W for W-912A, 60 W for W-906A
- Wide frequency response: 30 to 20,000 Hz \pm 1dB
- Low distortion and noise
- Excellent output regulation
- Built-in one-octave equalizer
- Built-in compressor
- Self-protection circuitry design
- Separate output terminals: 4 and 8 Ω , 25 and 70 V
- Extra space for customizing
- LED pilot light
- LED peak indicator
- Full range of plug-in modules
- Flush and surface mounting

3. NOMENCLATURE AND FUNCTIONS

[Front]

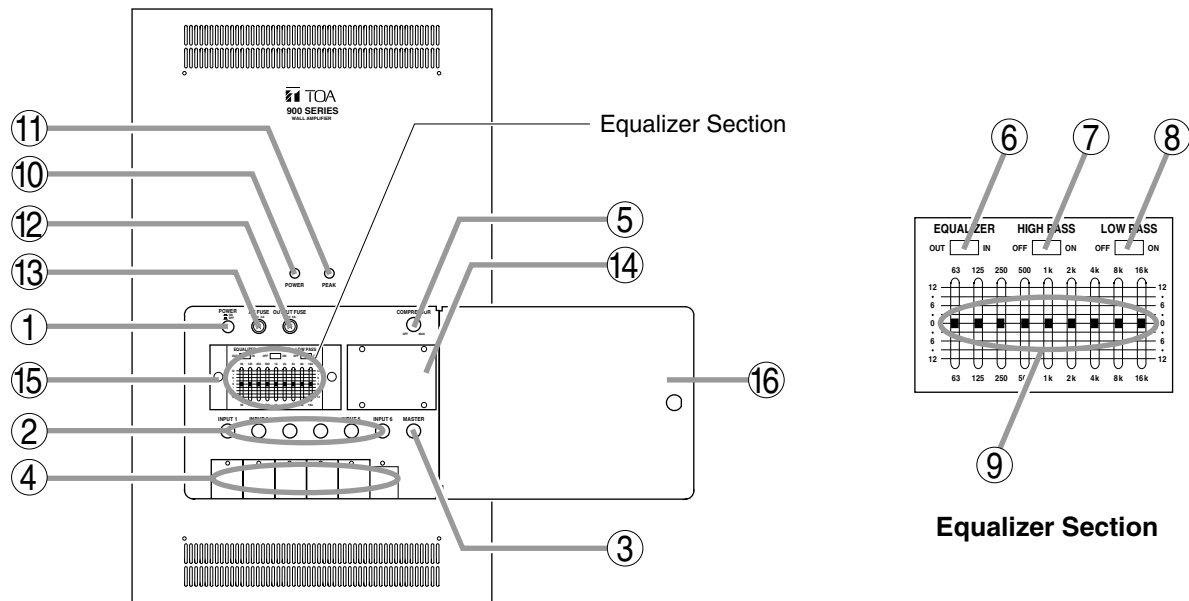

1. Power switch

Applies line power. Two-position push button switch for on-off modes.

2. Input volume controls

Adjust gain of input 1 – 6 respectively.

3. Master volume controls

Adjust overall gain of unit.

4. Modules (optional)

Select appropriate modules according to the application.

5. Compressor control (limiter)

Setting the control switch to OFF position bypasses the compressor circuit and turning it clockwise will reduce the limiter level (will limit the output).

6. Equalizer switch

Place this switch in the IN position to activate an equalizer.

7. High-pass filter switch

Place this switch in the ON position to cut off unnecessary low frequency.

8. Low-pass filter switch

Place this switch in the ON position to cut off unnecessary high frequency.

9. Equalizer controls

9 band filters. 12 dB boots and cut at each center frequency.

10. Power indicator

Comes on when power is switched on.

11. Peak indicator

Comes on when the output signal reaches the rated output power level.

12. Output fuse

Prevents excessive current flow.

W-906A: 250 V, 6 A

W-912A: 250 V, 10 A

13. AC fuse

Prevents excessive current flow.

W-906A: 250 V, 3 A

W-912A: 250 V, 5 A

14. Blank panel (user's space)

The space of 103 (w) x 63 (h) x 95 (d) mm is provided. An optional expanding kit may be loaded in this space.

15. Equalizer security cover

Prevents inadvertent changes of the equalizer controls set at proper level.

16. Key-locked door

Prevents tampering.

[Front] (viewed with the front cover removed)

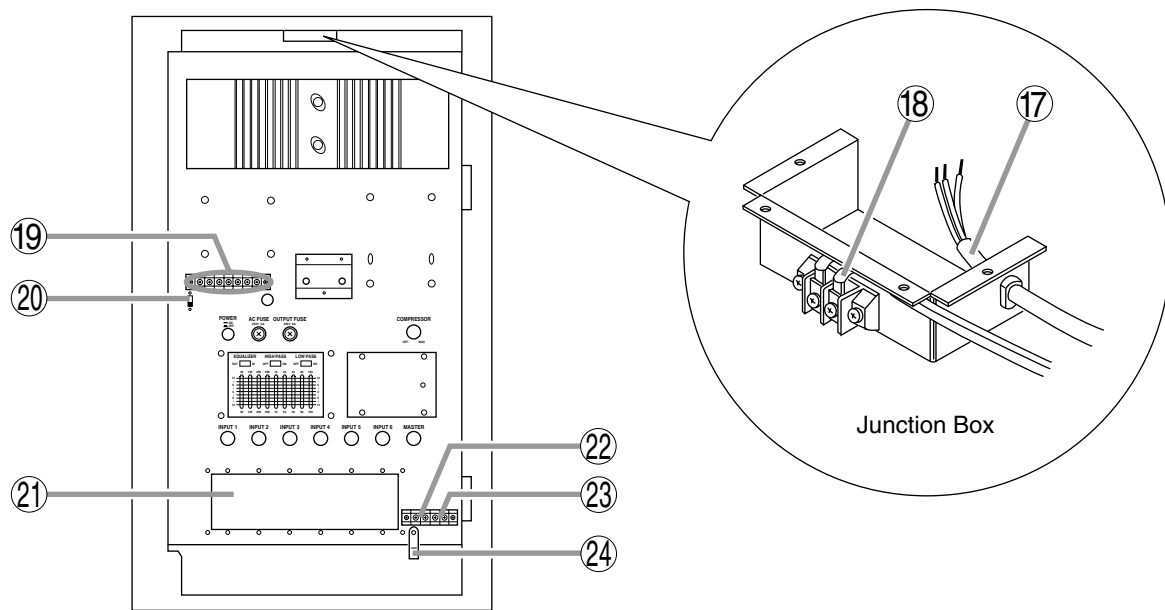

17. AC power cord

Connects to power source.

18. Speaker output terminals

Connects to speakers.

19. Output terminals

Select output impedance with this terminal.

20. Low-cut switch

Cuts off unnecessary low frequency.

21. Module input ports

Accept PLUG-IN MODULES which are optionally available. Module selection is determined by application.

22. Bridging input/output

This terminal is used as a mixing bus. Mixing is achieved when the similar terminal of another amplifier is connected to this terminal. The output level taken from this terminal is independent of the all CONTROLS (except INPUT VOLUME CONTROLS) so that the terminal can also be used as recording output. The input impedances of the equipment to be connected here should be more than 10 k Ω .

23. Mute terminal

With modules employing muting function, which are optionally available, the input signals fed to the modules are muted by short-circuiting at this terminal.

24. Cord clamp

Clamps off lead wires from module inputs, mute terminals and bridging input/output terminals.

4. INSTALLATION AND CONNECTION

Installing this amplifier requires the optional back box, which is Model BX-9F for flush mounting in any 4 inch wall and Model BX-9S for surface mounting.
Fix the back box first in installing the amplifier...

Installing Procedure

Step 1. Attach hinges to the back box by means of screws. (The hinges and screws are accessories supplied free of charge.)

Step 2. Fix the amplifier to the back box by inserting the amplifier bolts into the hinges as illustrated.

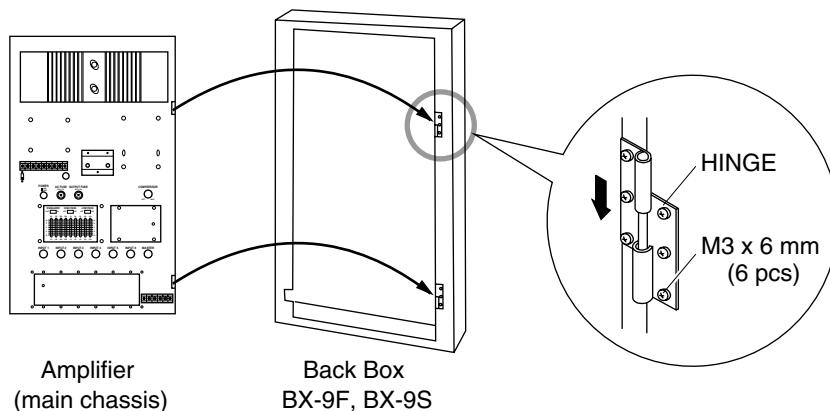

Step 3. Connecting power cable

Be sure to make proper cable connections according to color coding of the power cable.
After connection is completed, insulate sufficiently the jointed sections and put them in a junction box.

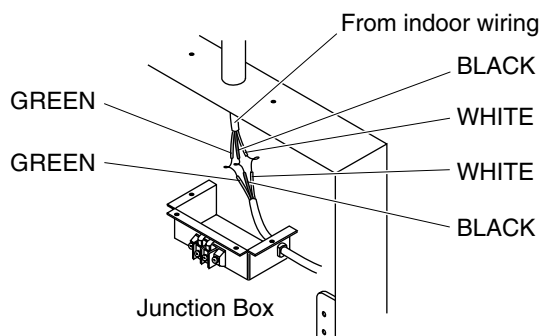

Step 4. Attaching the junction box to the back box

The BX-9F differs from the BX-9S in the way to attach the junction box to the back box.

[BX-9F]

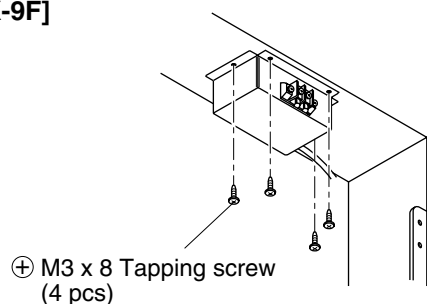

[BX-9S]

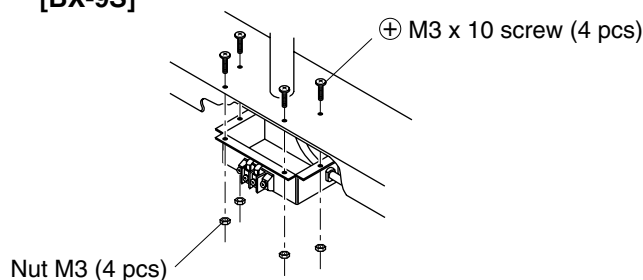

Step 5. Connecting the speaker cable

Connect the speaker cable to the speaker terminals on the junction box. Amplifier output impedance may be selected at the output terminals on the front panel.

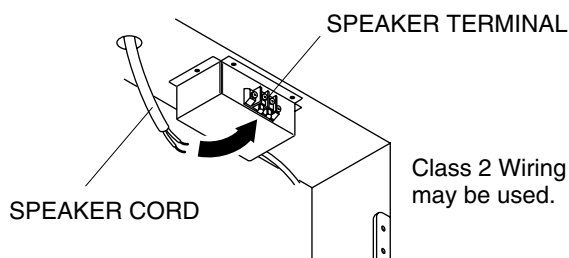

Step 6. Fixing the amplifier

Fix the amplifier to the back box with screws after connecting the power cable and the speaker cable.

M4 x 10 mm Screw
(3 pcs)

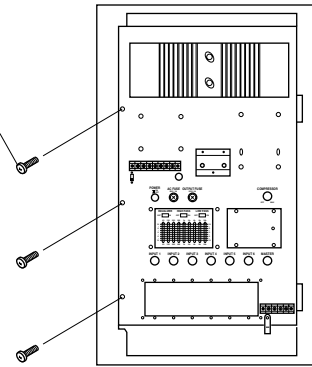

Step 7. Selecting output impedance

Select appropriate output impedance that matches the speaker to be used. Class 2 wiring may be used.

Since these outputs consist of 8 Ω, 25 V and 70 V via the output transformer (matching transformer) and direct output of 4 Ω, the connecting method differs in each case. See the following diagram.

Note: Impedances indicated below imply total speaker system (load) impedances.

- When connecting speakers to any one of the outputs of 8 Ω, 25 V or 70 V (BALANCED TRANSFORMER OUTPUT); connect as illustrated below.

[W-906A]

Change cable connection for required impedance according to the speaker used.

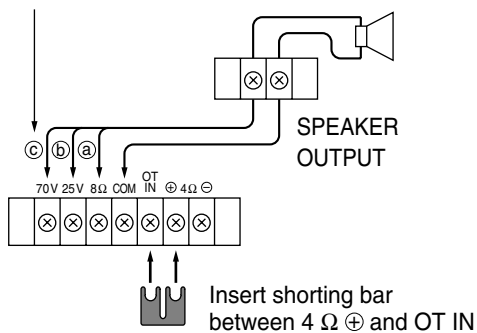

- Ⓐ 8 Ω
- or
- Ⓑ 10.4 Ω (25 V line)
- or
- Ⓒ 83 Ω (70 V line)

[W-912A]

Change cable connection for required impedance according to the speaker used.

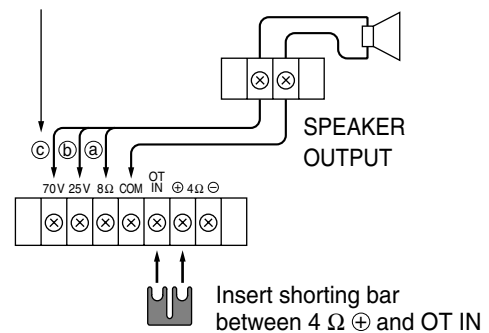

- Ⓐ 8 Ω
- or
- Ⓑ 5.2 Ω (25 V line)
- or
- Ⓒ 41 Ω (70 V line)

Note

In this case, the LOW-CUT SWITCH should be in "CUT" position. The amplifier is characteristically flat even in the low frequency range. Therefore, in TRANS OUTPUT, the acoustic effect and frequency-response characteristics may be altered. In TRANS OUTPUT, cut off unnecessary low frequency to obtain the best acoustic condition.

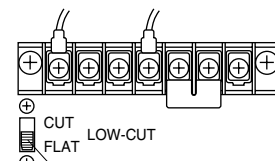

Place the LOW-CUT SWITCH in "CUT" position

- When connecting speakers to the 4 Ω, output (UNBALANCED DIRECT OUTPUT); connect as illustrated below.

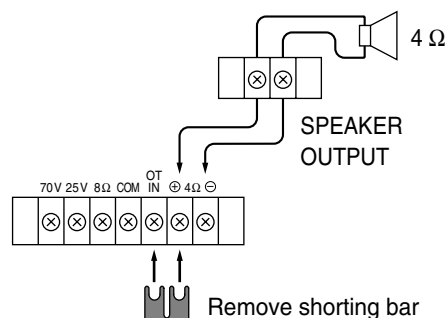

Step 8. Input connections

- This unit has six INPUT PORTS for plug-in modules. Select the desired modules for each application.
- Plug the modules into INPUT PORTS, sliding them between the guide rails, and secure each with two screws.

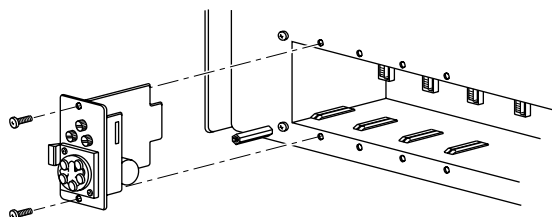

CAUTION

Modules should not be inserted or removed while the amplifier is turned on.

- When not all INPUT PORTS are occupied, cover the vacant PORTS with back panels, and secure them with screws.
- PLUG-IN MODULES are provided in the following:

Balanced low impedance microphone preamp. module (with presettable low-cut filter, high-cut filter and gain controls)	H-01, H-21
Balanced low impedance microphone preamp. module (with presettable low-cut filter, and gain controls)	H-02, H-22
Unbalanced high impedance microphone preamp. module (with presettable low-cut filter, high-cut filter and gain control)	H-03
Equalized mag. phono preamp. module (with presettable gain controls)	E-01, E-11
Unbalanced high impedance auxiliary preamp. module (with presettable gain control)	X-01, X-11, X-21
Balanced 10 k Ω bridging transformer module	B-01, B-11
Balanced 600 Ω line matching transformer module	L-01
Balanced paging input module (with presettable gain control and MUTE Delay)	I-01
Balanced 600 Ω line output module (with presettable gain control)	T-01
Signal tone generator module (with presettable output level control) <ul style="list-style-type: none"> · 1 kHz sine wave · Yelp and buzzer · One-tone chime and continuous one-tone chime 	S-01 S-02 S-03

- With H-21, H-22 and X-21 modules employing volume remote control functions, connecting a potentiometer (10 k Ω) to the terminal of any of these modules permits the sound volume to be remotely controlled by means of the connected potentiometer.
 - E-11, X-11 and B-11 modules incorporate muting functions. If a switch is connected to MUTE TERMINAL on the rear panel of the amplifier and closed, these input signals can be muted.
 - T-01 is used to feed out mixed signals to external equipment.
 - T-01 should be inserted only in Input Port 5 or 6. (See the supplied "NEW 900 SERIES MODULES" manual for details.)
- Unite these cables to allow free rotation of the amplifier.

Note

Use modules with suffix "S" for standard input port.

Input Expander

The optional expanding kit (WE-2) is necessary to increase the number of input. Up to two inputs may be added by loading the expanding kit in the user's space. For details, refer to the instruction manual of the kit.

CAUTION

Installation of optional items should be performed by a qualified service personnel.

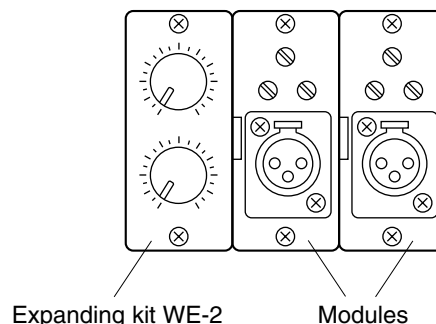

Note

When the temperature of heat sink exceeds 105°C, the protection circuit is activated and the output is disconnected from the circuit. The signal automatically begins to be output as the temperature goes down. In such a case, confirm whether or not unit is overloaded or operated on an excessive output.

5. SERVICING

Unpacking

Upon receipt of the amplifier shipment, please inspect for any damage incurred in transit. If damage is found, please notify your local TOA representative and the transportation company immediately.

State date, nature of damage, whether any damage was noticed on the shipping container, prior to unpacking. Please give waybill number of shipping order.

Failure

Should amplifier fail, contact your nearest TOA authorized contractor or service center.

6. OPERATING

When all connections are completed, turn power switch on.

Then, the power indicator is illuminated. Approx. 5 seconds after switching power on, the amplifier comes into operation.

Adjustment of Volume

Adjust the individual input and master volume controls to obtain appropriate output level.

When the peak indicator remains lit, reduce the sound volume to turn it off. If the system is operated with the peak indicator lighting, it downgrades sound quality.

Adjusting graphic equalizer

The one-octave graphic equalizer tailors sound system frequency response to room acoustics, reducing feedback tendencies and improving intelligibility. Characteristic of this equalizer is as per below graph. Adjust it to obtain the desired frequency response by actually hearing the sound or by using pink noise.

To make the adjustment, place the EQ switch in the IN position.

If a control knob is moved toward the plus (+) direction, center frequency is boosted and if toward the minus (-) direction, it is cut. Placing the EQ switch in the OUT position bypasses the equalizer circuit and makes frequency response flat.

Filter

When the HIGH PASS FILTER switch is in the ON position, low frequency is cut. In this event, low frequency below 180 Hz may be cut at a 12 dB/OCTAVE rate. When LOW PASS FILTER switch is in the ON position, high frequency of 7 kHz or higher may be cut at a 12 dB/OCTAVE rate.

To bypass the filter, place the filter in the OFF position.

Compressor

If the COMPRESSOR CONTROL switch is set to OFF, it bypasses the compressor circuit. Turn it clockwise to activate the compressor and to adjust the limiting level. Since turning it fully clockwise far too much limits the output level, set the switch at a maximum point that does not cause the peak indicator to light up.

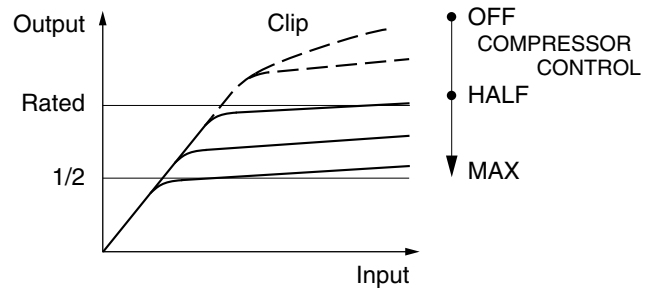

Adjusting release time

Compressor release time is set at 2 seconds on the amplifier supplied from the factory. Adjust the release time, if necessary, by means of the release time controls at the rear of the amplifier.

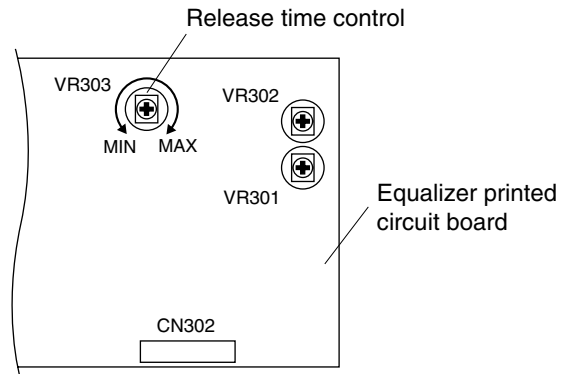

Output Fuse

Each amplifier has an output fuse to protect the amplifier from short-circuiting at the output or overloading. Check the fuse when speakers connected do not sound even if the meter deflects normally. If the fuse blew, replace with the same type fuse after confirming the following points.

- Step 1.** Speaker cables are not short-circuited or the load does not exceed the rating specified.
- Step 2.** Wiring is correctly done at the output terminal board.

7. HOW TO USE VOLUME CONTROL COVER

- Step 1.** After adjusting the input volume control, remove its knob.
- Step 2.** Attach the supplied volume control cover to the chassis in place of the knob.

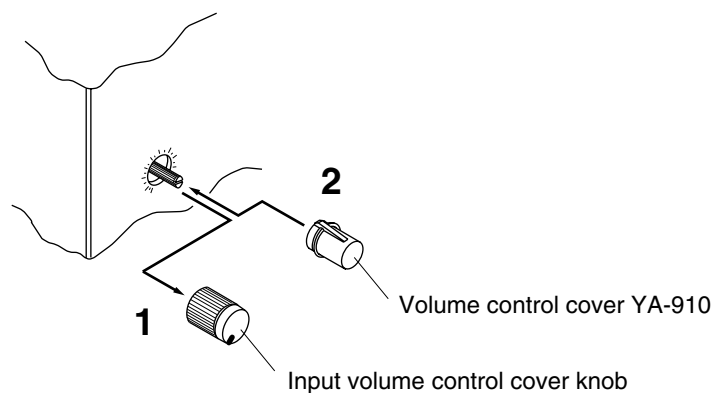

Note: The unit comes with 3 volume control covers as standard accessories. Ask for the optional one model YA-910 as necessary.

8. OUTPUT EQ CHARACTERISTIC

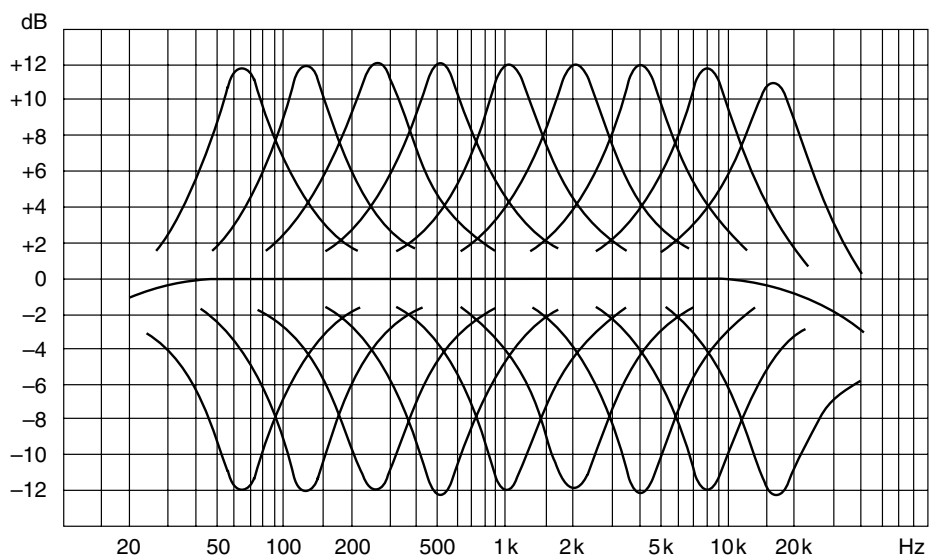

9. BLOCK DIAGRAM

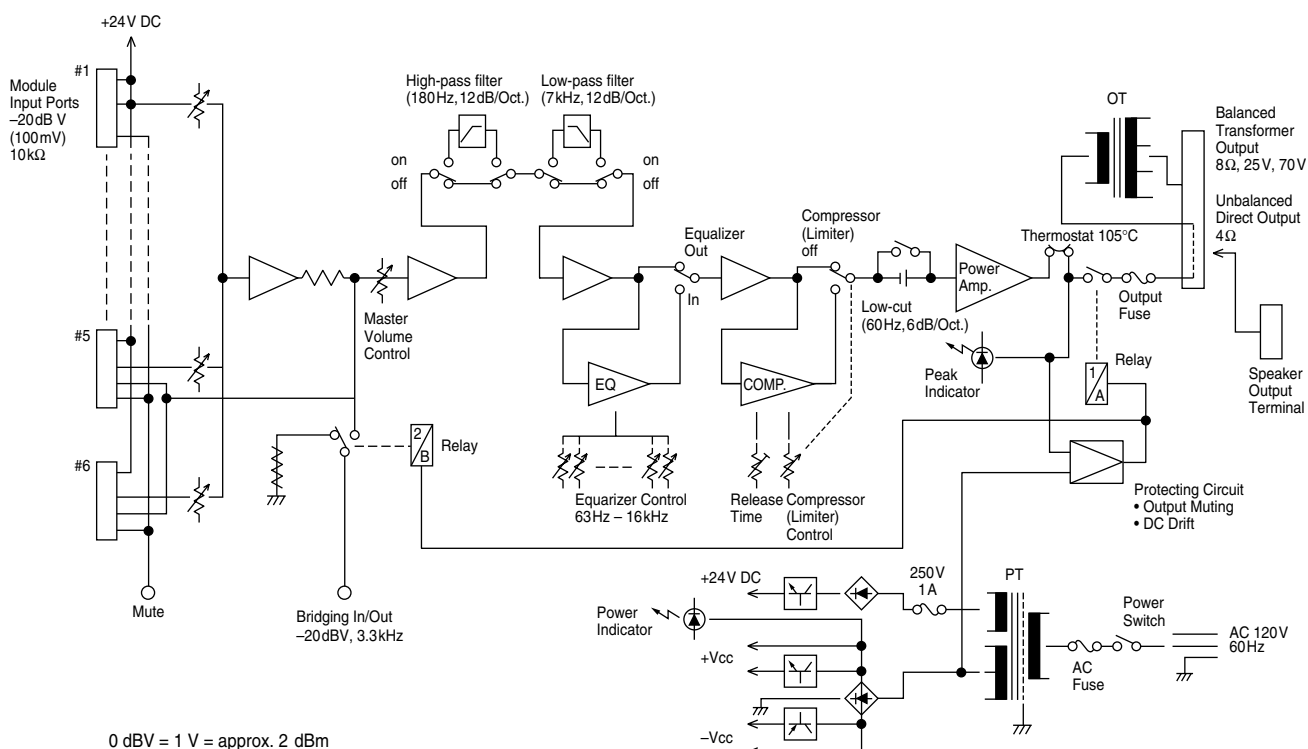

10. SPECIFICATIONS

Model No.	W-906A	W-912A
Type	Wall mounting 6-channel mixer power amplifier	
Output Power	60 W RMS	120 W RMS
Power Bandwidth	(D): 20 – 20,000 Hz, 0.5% THD (T): 20 – 20,000 Hz, 0.5% THD	
Frequency Response	(D): 30 – 20,000 Hz, ± 1 dB (T): 30 – 15,000 Hz, ± 1 dB (T): 30 – 20,000 Hz, ± 1 dB, – 3 dB	
Total Harmonic Distortion	0.02% at 1 kHz, rated output	
Inputs	Six input ports: Each port accepts any input module except T-01S. Use T-01S only in port 5 or 6. One bridging input/output.	
Input Sensitivity/Impedance	Input ports 1 to 6: 100 mV, 10 k Ω Bridging input/output: 100 mV, 3.3 k Ω	
Outputs	(T): 8 Ω , 25 V and 70 V, balanced (D): 4 Ω , unbalanced	
Output Regulation (1 kHz)	(D): Less than 0.5 dB, no load to full load. (T): Less than 1.0 dB, no load to full load.	
Signal to Noise Ratio (Band Pass: 20 – 20,000 Hz)	Controls OFF: 90 dB Master volume Max: 77 dB Equalizer IN: 88 dB Compressor IN: 84 dB	
Compression	Attack time: No greater than 2 milliseconds Compression range: 20 dB Release time: Adjustable 20 – 2,000 milliseconds Distortion: Less than 1%	
Equalization	9-Band ISO One-octave graphic equalizer Center frequencies: 63, 125, 250, 500, 1000, 2000, 4000, 8000, 16000 Hz Equalization range: ± 12 dB	
Filters	High-pass filter: 180 Hz, 12 dB/octave Low-pass filter: 7 kHz, 12 dB/octave	
Controls	6 Input gain controls, 1 Master gain control, 1 Compression level control, 9 Equalizer controls, 1 Power ON/OFF switch, 1 Equalizer ON/OFF switch, 1 High-pass filter ON/OFF switch, 1 Low-pass filter ON/OFF switch, 1 Low-cut switch (60 Hz, 6 dB/octave, inside)	
Indicators	1 LED power indicator, 1 LED peak indicator	
Protection	Self-protection, with 2 AC fuses (1 inside) and 1 output fuse	
Connectors	Input 1 to 6: Card-edge connector Output: Screw-terminal strip Bridging input/output: Screw-terminal strip Mute: Screw-terminal strip AC Power cord: SJT 3-conductor	
Power Consumption	AC120 V, 60 Hz, 100 W	AC120 V, 60 Hz, 180 W
Color	Silver	
Dimensions	Face panel: 412 (w) x 680 (h) x 28 (d) mm BX-9F Back Box: 362 (w) x 628 (h) x 98 (d) mm BX-9S Back Box: 412 (w) x 680 (h) x 98 (d) mm	
Weight	13.7 kg (without input modules and back box)	17.3 kg (without input modules and back box)
Other Features	Output disconnect for approx. 5 sec after power turned on. Muting Function: Accomplished by input module X-11S, B-11S and E-11S.	

* Power Bandwidth and Frequency Response are from input port to power amplifier output.

Note: The design and specifications are subject to change without notice for improvement.

• **Accessories**

Volume control cover	3	Flange nut	4
Key (for door)	2	Tapping screw 3 x 8	4
Lift-off hinge (receptacle)	2	Inch screw	4
Machine screw M4 x 10	5	Indication label	1
Machine screw M3 x 6	6	Instruction manual (W-906A/-912A)	1
Machine screw M3 x 10	4	Instruction manual (New 900 series modules)	1

• **Optional products**

Flush-mounting (in-wall) back box: BX-9F	Expanding kit: WE-2
Surface-mounting (on-wall) back box: BX-9S	Volume control cover (black): YA-910

Free Manuals Download Website

<http://myh66.com>

<http://usermanuals.us>

<http://www.somanuals.com>

<http://www.4manuals.cc>

<http://www.manual-lib.com>

<http://www.404manual.com>

<http://www.luxmanual.com>

<http://aubethermostatmanual.com>

Golf course search by state

<http://golfingnear.com>

Email search by domain

<http://emailbydomain.com>

Auto manuals search

<http://auto.somanuals.com>

TV manuals search

<http://tv.somanuals.com>