

# delfino

## REVERSIBLE HEALTH GRILL & GRIDDLE



Instruction Booklet  
Model: DLHG-443

## IMPORTANT SAFEGUARDS

When using electrical appliances, basic safety precautions should always be followed including the following:

1. Read all instructions.
2. **DO NOT** touch hot surfaces. Use handles or knobs.
3. To protect against electrical hazards, do not immerse cord, plugs, or the appliance in water or other liquid.
4. Close supervision is necessary when any appliance is used by or near children.
5. Unplug from outlet when not in use and before cleaning. Allow to cool before putting on or taking off parts, and before cleaning the appliance.
6. **DO NOT** operate any appliance with a damaged cord or plug or after the appliance malfunctions, or has been damaged in any manner. Return appliance to Salton for examination, repair or adjustment. See "Warranty" section.
7. The use of accessories or attachments not recommended may cause hazards.
8. **DO NOT** use outdoors.
9. **DO NOT** let cord hang over edge of table or counter, or touch hot surfaces.
10. **DO NOT** place on or near a hot gas or electric burner, or in a heated oven.
11. Extreme caution must be used when moving an appliance containing hot liquids. **DO NOT** move the unit when it is still hot.
12. Prior to connecting or disconnecting plug from wall outlet, turn any control to "Off".
13. This appliance is for Household Use Only. **DO NOT** use appliance for other than its intended use.
14. **DO NOT** leave unit unattended while in use.
15. **DO NOT** touch the metallic parts of the unit while the appliance is operating. These can become very hot.
16. Always unplug grill immediately after using and allow to cool before cleaning and storing.
17. Always place grill on a heat resistant surface.
18. Never place anything between the grill plate and the food i.e.: dish, aluminum foil, etc.
19. **CAUTION:** This appliance generates heat during use. Proper precautions must be taken to prevent the risk of burns, fires or other damage to property caused by touching the sides or top while in use or during cooling.

# SAVE THESE INSTRUCTIONS

## HOUSEHOLD USE ONLY

### POLARIZED PLUG

This appliance has a polarized plug (one blade is wider than the other). To reduce the risk of electric shock, this plug will fit in a polarized outlet only one way. If the plug does not fit fully in the outlet, reverse the plug. If it still does not fit, contact a qualified electrician. Do not modify the plug in any way.

### DESCRIPTION OF PARTS

1. Base
2. Drip tray
3. Grill Plate
4. Griddle Plate (Underneath the Grill Plate)
5. Cool-touch Handles
6. Temperature Control and Power Cord
7. Temperature Control Receptacle
8. Temperature Control Support
9. Scraper

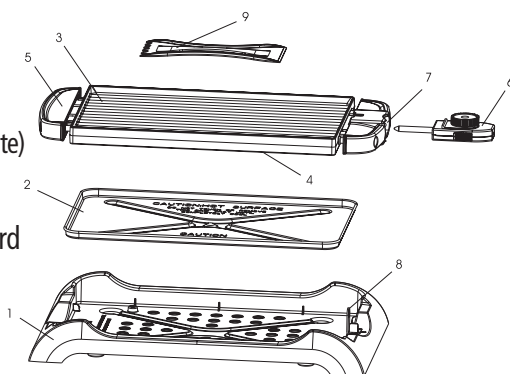

### BEFORE FIRST USE

1. Read all instructions carefully and keep them for future reference.
2. Remove all packaging, labels, etc.
3. Wash the Grill & Griddle Plate, Base and Drip Tray in warm soapy water or in the dishwasher to remove any residue from the manufacturing process. **DO NOT USE THE DISHWASHER DRY CYCLE AND DO NOT ALLOW THE GRILL & GRIDDLE TO SOAK OVERNIGHT.** Never use any metal objects, scouring pads or harsh abrasive cleansers on the cooking surface. **NOTE: NEVER IMMERSE THE TEMPERATURE CONTROL OR THE POWER CORD IN WATER OR ANY OTHER LIQUID.**
4. Dry thoroughly with a soft cloth.
5. Condition the cooking surface by applying a light coating of vegetable oil or use a non-stick cooking spray. Wipe off excess oil.

## HOW TO USE

1. Place unit on a flat surface, close to a 120 volt wall outlet.
2. Assemble by placing the Drip Tray in the Base.
3. Place either the Grill side up or the Griddle side up on the Base by lining up the Temperature Control Receptacle with the Temperature Control Support.
4. Plug the Temperature Control into the Temperature Control Receptacle.  
**NOTE:** The Temperature Control cannot be plugged in unless the Grill & Griddle Plate is placed properly into the base.
5. Plug the Power Cord into a 120V outlet. Turn the dial so that the light is pointed to the desired temperature. The red indicator light will illuminate indicating that the unit is preheating. When the light goes out the unit is ready to use. **NOTE:** During cooking the light will go on and off indicating that the selected temperature is being maintained.

The following table is a guide. The amount of time depends upon the thickness and desired degree of doneness of food.

### Grill Cooking Chart

Food	Temperature	Approx. Time
Chicken breast, boneless	350°F (175°C)	15 – 20 minutes
Chops: Lamb, Pork, Veal	350°F (175°C)	12 – 15 minutes
Fish	350°F (175°C)	10 – 12 minutes
Hamburgers	400°F (205°C)	14 – 16 minutes
Shrimp	350°F (175°C)	8 – 12 minutes
Spare ribs	350°F (175°C)	25 – 30 minutes
Steak	350°F (175°C)	15 – 20 minutes

### Griddle Cooking Chart

Food	Temperature	Approx. Time
Bacon	350°F (175°C)	4 – 6 minutes
Eggs	300°F (150°C)	3 – 5 minutes
French toast	375°F (190°C)	8 – 10 minutes
Grill cheese sandwiches	350°F (175°C)	6 – 8 minutes
Hash browns	350°F (175°C)	12 – 14 minutes
Pancakes	375°F (190°C)	4 – 6 minutes
Sausages	325°F (160°C)	12 – 15 minutes

## HELPFUL HINTS

1. For best browning results and grill marks when cooking hamburgers, steaks, hot dogs, sausages, chicken and other meats, adjust the Temperature Control to the maximum setting (400°F/205°C).
2. Use a medium or low setting (250°F/120°C to 350°F/175°C) to reheat previously cooked foods, keep food warm or to grill more delicate food, like fish.
3. If desired when grilling, brush barbecue sauce on food during the last 5 to 10 minutes of cooking.
4. Par-boil ribs before grilling.
5. Preheat to the desired temperature, especially when cooking foods that may run such as eggs and pancakes.
6. When using oil on the Griddle, **DO NOT** add more than 2 tablespoons. Oil should be added before preheating the Griddle.
7. To use the Griddle as a warming tray set the control to 200°F/95°C.
8. Excess liquid can be drained through the holes in the Grill & Griddle Plate into the Drip Tray.
9. If you do not wish to use oil when cooking, you should season the Grill & Griddle Plate by brushing the surface with a light coating of vegetable oil. Let the oil remain on the surface for a few minutes then wipe with a dry paper towel. Preheat to the desired temperature and the Grill & Griddle is ready to use
10. **DO NOT** use metal utensils on the Grill or Griddle Plate as they may scratch the non-stick surface. Use plastic or rubber utensils. **DO NOT** cut food on the Grill or Griddle Plate.

## CARE AND CLEANING

1. Turn the temperature Control to "Off", unplug the unit from the wall outlet and allow to cool completely.
2. Remove the Temperature Control from the Temperature Control Receptacle. If necessary, wipe the Temperature Control and the Power Cord with a damp cloth. **NEVER IMMERSE THE TEMPERATURE CONTROL OR THE POWER CORD IN WATER OR ANY OTHER LIQUID.**

3. Use the grooved side of the scraper to clean the ribbed grill surface. Use the flat side of the scraper to clean the flat griddle surface. Push excess grease towards drip holes.
4. Remove the Drip Tray and dispose of waste.
5. The Drip Tray, the Grill & Griddle plate can be washed in warm soapy water or in the dishwasher. **DO NOT USE THE DISHWASHER DRY CYCLE AND DO NOT ALLOW THE GRILL OR GRIDDLE TO SOAK OVERNIGHT.**  
**NOTE:** For stubborn spots, use a soft plastic mesh pad or other products that are "safe for cleaning non-stick surfaces", rinse with clear water and dry thoroughly. Never use any metal objects, scouring pads or harsh abrasive cleansers on the cooking surface.
6. After each thorough cleaning, the Grill and Griddle Plates should be seasoned. Brush the cool surface with a light coating of vegetable oil. Allow the oil to remain on the surface for a few minutes, then wipe with a paper towel. The Grill & Griddle is now ready to use.

**NOTE:** With repeated use, the non-stick coating on the grill and griddle may change colour. This is normal and will not affect the non-stick properties.

A short supply cord is provided to reduce the hazards of becoming entangled in or tripping over a long cord. Extension cords may be used if care is exercised in their use. If an extension cord is used, the marked electrical rating of the detachable power-supply cord or extension cord should be at least as great as the electrical rating of the appliance. If the appliance is of the grounded type, the extension cord should be a grounded 3-wire cord. The extension cord should be arranged so that it will not drape over the counter top or table top, where it can be pulled on by children or tripped over.

## LIMITED WARRANTY

Toastess International warrants that this appliance shall be free from defects in material and workmanship for a period of one year from the date of purchase. During this 'in-warranty' period, defective products will be repaired or replaced at the discretion of the retailer and/or Toastess International. This warranty covers normal domestic usage and does not cover damage which occurs in shipment or failure which results from alteration, accident, misuse, abuse, glass breakage, neglect, commercial use or improper maintenance.

A defective product should be returned to the original place of purchase within the retailer's stipulated return/exchange period\*. If you are unable to have a defective product replaced under warranty by the retailer, please check our website at "www.toastess.com" for the service centre nearest you or you may contact us for assistance by mail, e-mail, fax or telephone as listed below.

To ensure prompt 'in-warranty' service, securely package and return the product to us prepaid. Be sure to include the original proof of purchase and a description of the defect along with your address and zip/postal code.

For repairs not covered by the warranty, please contact us for assistance.

# TOASTESS®

## TOASTESS INTERNATIONAL

Customer Service Department

81A Brunswick

Dollard-des-Ormeaux

Québec, Canada H9B 2J5

E-mail: [info@toastess.com](mailto:info@toastess.com)

Fax: 514-685-8300

Tel: 514-685-2820

\* Return/exchange policies at each retailer vary and may differ from the Toastess International 1 year limited warranty period.

## Free Manuals Download Website

<http://myh66.com>

<http://usermanuals.us>

<http://www.somanuals.com>

<http://www.4manuals.cc>

<http://www.manual-lib.com>

<http://www.404manual.com>

<http://www.luxmanual.com>

<http://aubethermostatmanual.com>

Golf course search by state

<http://golfingnear.com>

Email search by domain

<http://emailbydomain.com>

Auto manuals search

<http://auto.somanuals.com>

TV manuals search

<http://tv.somanuals.com>