

TOASTESS® *Silhouette*

Programmable Slow Cooker
6.5 litre/quart capacity



Instruction Booklet

Model : TSC-310

IMPORTANT SAFEGUARDS

When using electrical appliances, basic safety precautions should always be followed including the following:

1. Read all instructions.
2. Do not touch hot surfaces. Use handles or knobs. Use potholders when removing lid or handling hot containers.
3. To protect against electrical hazards, do not immerse cord, plugs, or the Base in water or other liquid.
4. Close supervision is necessary when any appliance is used by or near children.
5. Unplug from outlet when not in use or before putting on or taking off parts. Allow to cool before cleaning.
6. Do not operate any appliance with a damaged cord or plug or after the appliance malfunctions, or is dropped or damaged in any manner. Return appliance to Toastess for examination, repair or adjustment. See Warranty section.
7. The use of accessories or attachments, not recommended or sold by Toastess may cause fire, electric shock or injury.
8. Do not use outdoors.
9. Do not let cord hang over edge of table or counter, or touch hot surfaces.
10. Do not place appliance base on or near a hot gas or electric burner, or in a heated oven.
11. Extreme caution must be used when moving an appliance containing hot liquids.
12. Always attach plug to appliance first, then plug cord into the wall outlet. To disconnect, turn any control to "OFF", then remove plug from wall outlet.
13. This appliance is for Household Use Only. Do not use appliance for other than intended use.
14. This appliance generates steam. Do not operate uncovered.
15. Do not block steam from venting around edges of lid. Never block any steam vent holes.
16. Lift and open Lid carefully to avoid scalding and allow water to drip into Casserole.
17. Containers are designed for use with this appliance only. They must never be used on a range top. Do not set a hot container on a wet or cold surface. Do not use a cracked container.

SAVE THESE INSTRUCTIONS

HOUSEHOLD USE ONLY

2

POLARIZED PLUG

This appliance has a polarized plug (one blade is wider than the other). To reduce the risk of electric shock, this plug will fit in a polarized outlet only one way. If the plug does not fit fully in the outlet, reverse the plug. If it still does not fit, contact a qualified electrician. Do not modify the plug in any way.

INTRODUCTION

The Programmable Slow Cooker is an attractive, convenient and easy to use appliance that will help you prepare meals for the whole family with minimum effort. The Oval Ceramic Casserole and Glass Lid double as a handy Casserole so the meal can be brought right to the table. They are dishwasher safe for easy clean ups.

DESCRIPTION OF PARTS

1. Cooking Base
- 2) Handles
- 3) Electronic Control
 - a) Digital Display
 - b) Temperature Button
 - c) Cook Time Button
 - d) Indicator lights (High, Low and Warm)
- 4) Glass Lid
- 5) Ceramic Casserole

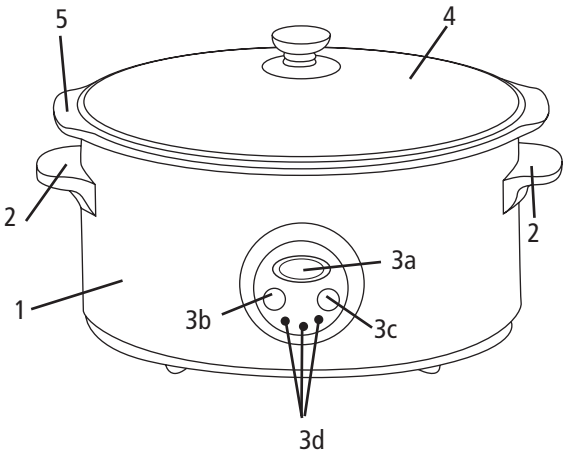

BEFORE FIRST USE

- Unpack and remove all parts and packaging materials from the carton.
- **DO NOT** plug the power cord into any outlet before reading these instructions.
- Wash the Casserole and Lid in warm, soapy water. Rinse and dry thoroughly.
- Wipe the interior and exterior of the Base with a clean, damp cloth. Dry thoroughly with a soft polishing cloth.

- Place the Slow Cooker on a level, dry surface. Place Casserole in Base and add 2 cups (500 ml) of water. Cover with Lid and plug cord into wall outlet. Follow the instructions in the "How to Use the Slow Cooker" section and allow the unit to cook on high for 30 minutes.
- Once the time has elapsed, unplug the Slow Cooker and allow it to cool. Remove the Casserole and discard water.
- Rinse Casserole and Lid. Dry thoroughly and place back in the Base.

NOTE:

DO NOT use harsh detergents or abrasive cleansers on any parts of the appliance.

DO NOT immerse the Base or power cord and plug in water or any other liquid.

HOW TO USE CERAMIC CASSEROLE

IMPORTANT PRECAUTIONS: Like any ceramic, the Casserole may crack or break if not handled properly resulting in injury or property damage.

To prevent damage to the Casserole:

- Always handle with care as all ceramic is breakable.
- Always use potholders when handling hot containers.
- **DO NOT** place hot Ceramic Casserole on counter. Use heat resistant trivet.
- **DO NOT** place Ceramic Casserole or Lid on range top burner, under a broiling or microwave browning element or in a toaster oven.
- **DO NOT** place hot Ceramic Casserole or Lid in a sink or on cold wet surfaces.
- **DO NOT** use the Ceramic Casserole to pop corn, caramelize sugar or make candy.
- **DO NOT** use abrasive cleansers or scouring pads or any object that could scratch the Ceramic Casserole or Lid.
- **DO NOT** repair or use if any part is chipped, cracked or broken.

USE: The Ceramic Casserole may be used in a conventional, convection, or microwave oven so long as it is not heated under a broiler or top browning element. NEVER use the Glass Lid in any type of oven. Both the Glass Lid and Ceramic Casserole can be cleaned in a dishwasher and also be used to store food in the refrigerator or freezer.

CARE: Use only wooden or plastic utensils. Metal utensils can scratch or mark the ceramic. The Casserole can be washed by hand or in a dishwasher.

DO NOT allow the Ceramic Casserole to soak or stand in water for an extended period of time. Heating the Casserole after soaking may cause the surface to craze. If scouring is required use only plastic or nylon pads with non-abrasive cleansers.

- **NEVER** subject the Casserole to sudden temperature changes such as moving it from the refrigerator directly into the oven or immersing it in water when it is hot.
- **NEVER** add cold water to a hot Ceramic Casserole.
- **NEVER** place it in contact with direct intense heat such as on a range burner or under a broiler element.
- **NEVER** heat the Casserole when it is empty. **NEVER** preheat the Base.
- **NEVER** add cold food from the refrigerator directly to the Casserole.
- **ALWAYS** unplug the Base and allow the Casserole to cool before cleaning.

HOW TO USE THE GLASS LID

IMPORTANT PRECAUTIONS: The Glass Lid may shatter if exposed to direct heat or sudden temperature changes. Chips, cracks or deep scratches may also weaken the Lid. If the Lid becomes chipped, cracked or scratched, do not use it. Discard it and order a replacement.

ALWAYS allow Lid to cool on a dry heat resistant surface before handling. **NEVER** place it on a cold or wet surface as this may cause it to crack or shatter.

NEVER uses the Glass Lid in a conventional, convection or microwave oven.

HOW TO USE SLOW COOKER

A Slow Cooker is easy to use but it is different from conventional cooking. This booklet is intended to be used as a general guideline and contains several suggestions and helpful hints for successful slow cooking. One of the benefits of slow cooking is that meals can be prepared in advance and the cooking time can be set so that the food is ready to serve at the appropriate time. There is an abundance of recipes specifically designed for slow cooking that can be easily found on the internet or in recipe books in your local bookstores and libraries.

1. Place the Slow Cooker on a dry level surface. Add recipe ingredients to the Ceramic Casserole and cover with Lid. Place Ceramic Casserole in Slow Cooker base.
2. Plug unit into the wall outlet. The digital display will flash "- - - -".
3. Press the Temperature Button to select Low, High or Warm. (Press once for High, twice for Low, 3 times for Warm and 4 times for Stand Time.) The default setting of 6 hours (6:00) will be shown in the Digital Display if you have selected Low, High or Warm. Nothing will be shown in the Digital Display if you have chosen "Stand Time". After 3 seconds the Indicator Light will illuminate beside High, Low or Warm, depending on your selected setting.
4. Set the required amount of time by pressing the "Cook Time" Button. Each time you press the Cook Time Button the time will increase by 30 minutes, to a maximum of 10 hours. If you don't press the Cook Time Button for 3 seconds the cooking time will be the time showing in the Display Window.

NOTE: If you would prefer less cooking time than the default setting of 6 hours, continue to press the Cook Time Button past 10 hours and the Cook Time will display 30 minutes. Press to increase the time by 30 minute increments.

5. Once the Cooking Time is finished, the unit will switch to "Stand Time" mode for 10 minutes. The Digital Display will countdown the 10 minute Stand Time then will automatically switch to Warm. The default time of the Warm cycle is 10 hours.
6. Once the 10 hours has elapsed, the slow cooker automatically switches to Stand Time. The indicator lights will go out and the Digital Display shows "----". Unplug the Slow Cooker from the wall outlet.
NOTE: To stop heating during the cooking process, press the Temperature Button until the remaining cooking time blinks in the Digital Display and the Indicator Light goes out. Wait 5 seconds and the unit will switch to the Stand-Time cycle and the Digital Display blinks "- - - -". Unplug the Slow Cooker.

HELPFUL HINTS USING THE SLOW COOKER

- The Lid does not form a tight seal with the Casserole. However, it should be centered on the Casserole for the best results.
- Stirring is not required while slow cooking. However, when cooking on High, stirring occasionally will help distribute flavours.
- For best results the Casserole should be at least half full.
- For soups and stews, leave a 2" (5 cm) space between the food and the top to allow ingredients to simmer. When cooking on High setting, keep checking from time to time as some soups and stews may come to a boil.
- When slow cooking it is more appropriate to use less tender, cheaper cuts of meat than the more expensive varieties. Remove excess fat before cooking and if called for, brown the meat on a range top using a metal frypan before adding meat to the Casserole.
- The greater the fat content in the meat the less liquid is required. When cooking meat with high fat content, place thick slices of onion under the meat so that it will not sit and cook in the fat. Roasts, when cooked on Low, may be prepared without adding any liquid.
- Use a meat thermometer to determine if the meat has been cooked to your taste.
- Fresh or thawed fish or seafood should be added to the Casserole only 1 hour before serving as they can fall apart during prolonged cooking.
- Since raw vegetables take longer to cook than meat, cut them into small pieces 1/2" (12mm) diameter before adding to Casserole.
- Milk, sour cream or other dairy products should be added just before serving as these tend to break down during prolonged cooking. You may substitute condensed milk or evaporated milk. Processed cheese may also be used instead of naturally aged cheese.
- Rice and pasta may be cooked separately or added uncooked to the ingredients no more than two hours before serving. If the pasta is uncooked there should be at least 2 cups (500 ml) of liquid in the Casserole. Stir occasionally to prevent pieces from sticking together.

- To thicken juices or make gravy at the end of the cooking cycle, make a smooth mixture of 2 to 4 tbsps. (30 – 60 ml) of cornstarch, 1/4 cup (60 ml) of water, and 2 tbsp. (30 ml) of butter. Remove cooked food from Casserole. Add the mixture to the juices remaining in the Casserole, set to High and stir until liquid thickens.
- Do not worry if the food remains in the Slow Cooker longer than planned. The Slow Cooker cooks very slowly and will be very forgiving if you are running a little late.

GENERAL RECIPE INSTRUCTIONS

1. Prepare recipe according to directions.
2. Place food in Ceramic Casserole and cover with Lid.
3. Use the following chart to help adapt your favorite recipes to the Slow Cooker. These times are approximate and should be used only as general guidelines.

TIME CONVERSION CHART

Regular cooking	Slow Cooker Time	
Time	Low	High
30 minutes	7 – 8 hours	3 – 4 hours
35 – 60 minutes	8 – 9 hours	4 – 5 hours
1 – 3 hours	9 – 10 hours	5 – 6 hours

4. Follow the instructions in the "How to Use the Slow Cooker" section.
5. Using a potholder or oven mitt, carefully remove Lid. **CAUTION:** When removing Lid, grasp the knob and slowly lift the side that is away from you to allow the steam to escape before setting the Lid aside. To avoid burns, always hold the Lid so that escaping steam flows away from your hands, arms and face.
6. Using potholders or oven mitts grasp the Ceramic Casserole by the handles on either end and remove from the Base.
7. Always place a trivet under the Casserole before placing on table or countertop. Serve contents.

HELPFUL HINTS FOR ADAPTING RECIPES

- The Low setting is recommended for all day cooking. Most meat and vegetable combinations require at least 7 hours on Low.
- For best flavour use whole leaf herbs and spice during the initial preparation. If ground herbs and spices are used, stir in during the last hour of cooking.
- The time required to cook is affected by many factors. The water and fat content of the food, its starting temperature, and the size of the pieces will all affect the cooking time. For example, meat cut into pieces will cook faster than a whole roast. Adjust the time accordingly.
- Recipes for vegetable casseroles must contain liquid to prevent scorching of the sides of the Casserole.
- You may choose to substitute ingredients in a recipe. For example, a 12 oz. can of chicken broth could be replaced by a 10 oz. can of tomato soup and 2 oz. of another liquid such as water or wine.
- Canned beans may be added directly to any recipe. However, dried beans (especially red kidney beans) should be soaked in water and boiled first. After boiling in 3 times their volume of unsalted water, discard water and add beans to recipe. NOTE: Beans must be softened completely before they are combined with sugary and/or acidic foods, as these have a hardening effect on beans. In this case, beans should be allowed to simmer until tender after boiling (about 1-1/2 hours).

CARE AND CLEANING

1. This appliance should be cleaned after every use. Before cleaning unplug the Base and allow the appliance to cool. **DO NOT** use harsh detergents or abrasive cleansers on any part of the appliance.
2. Wash the Casserole and Lid in warm soapy water. Rinse well and dry. If food sticks to the surface of the Casserole, fill it with warm soapy water and let stand for an hour before cleaning. Casserole and Lid may be washed in a dishwasher. To prevent damage place them carefully in a rack so that they do not touch each other or any other object during the cleaning cycles.
3. Wipe exterior and interior of Base with soft damp cloth. Dry with a soft cloth. **DO NOT** immerse the Base or power cord and plug in water or any other liquid.
4. To remove any stains from the Ceramic Casserole clean with non-abrasive cleanser or apply a thin paste of baking soda to the affected areas. To remove water spots or mineral deposits wipe with distilled white vinegar. Clean in warm soapy water, rinse and wipe dry with a soft cloth.
5. Store all parts of the Slow Cooker only once they are clean and dry. Never store when the Casserole is wet. To store, place Casserole inside Base and wrap Lid in a soft cloth or towel before storing upside down on the Casserole. Never wrap the power cord around the Base.

RECIPES

BEEF POT ROAST

3 lb. (1.4 kg.)	pot roast
1 tsp. (5 ml)	vegetable oil
1-1/2 tsp. (8 ml)	salt
1/4 tsp. (1.2 ml)	pepper
4	apples, cored and cut in large chunks
1	onion, sliced
1/2 cup (125 ml)	apple juice
3 tbsp. (45 ml)	flour
3 tbsp. (45 ml)	water

Trim excess fat from roast and coat meat with oil. Sprinkle with salt and pepper. Place apples and onions in the bottom of the ceramic casserole, then place roast on top of mixture. Pour in apple juice. Cover and cook on low setting for 8 – 10 hours. Remove the roast.

Make a paste with the flour and water and stir into the dripping in the ceramic casserole to make the gravy and cook until thickened. Slice the roast and serve with gravy.

CHILI

2 lbs. (900 g)	ground beef
2 cans	kidney beans, washed and drained
1 large can	tomatoes, drained
2	onions, large dice
1	green pepper, large dice
2	garlic cloves, peeled and minced
2 tbsp. (30 ml)	chili powder
1 tsp. (5 ml)	cumin
1 tsp. (5 ml)	pepper
1/2 tsp. (3 ml)	salt

In a large skillet, brown the ground beef and drain off the fat.

Add all ingredients into the ceramic casserole and stir. Cover and cook on low for 9 - 10 hours.

CHICKEN AND VEGETABLE CASSEROLE

6	half chicken breasts, bone in (3 – 4 lbs, 1.4 – 1.8g)
1/4 tsp. (1.5 ml)	paprika
1 tsp. (5 ml)	salt
1/4 (1.5 ml)	white pepper
2 tsp. (10 ml)	chicken stock powder
2 cups (500 ml)	mushrooms, sliced
1	small onion, small dice
1 cup (250 ml)	small baby carrots
3/4 cup (180 ml)	white wine
1/2 cup (125 ml)	evaporated milk
2 tbsp. (30 ml)	cornstarch

Remove skin from chicken. Mix the paprika, salt and pepper together. Sprinkle on chicken. Place chicken in ceramic casserole. Add chicken stock powder, mushrooms and onion. Pour wine over top. Do not stir.

Cover and cook on high for 2-1/2 to 3 hours. Remove chicken and vegetables and keep warm. In a small pot combine evaporated milk and cornstarch until 12 smooth. Gradually stir in 2 cups of the cooking liquid. Stir over medium heat until mixture comes to a boil and thickens. Serve with chicken and vegetables.

CHICKEN NOODLE SOUP

3 lbs. (1.4 kg)	chicken, cut up
2 qts. (2 L)	water
1 tbsp. (15 ml)	salt
1/2 tsp. (3 ml)	pepper
1	onion, diced
2	stalks celery, diced
2	carrots, diced
1	bay leaf
1/3 cup (85 ml)	parsley
6 oz. (140 g)	small pasta noodles

Place all ingredients except the noodles in the ceramic casserole. Cover and cook on low for 7 hours. Remove the chicken. Pull meat from the bones. Discard bones and cut chicken into bit size pieces. Return chicken to broth and add the noodles. Cook for 30 minutes on high. Remove bay leaf and serve. 12

BAKED BEANS

2	cans white beans
1/3 cup (85 ml)	molasses
1/4 cup (60 ml)	light brown sugar
1	onion, diced
1/4 lb (60 g)	bacon, diced
1 tbsp. (15 ml)	mustard
1/2 tsp. (3 ml)	salt

Rinse beans. Combine all ingredients in the ceramic casserole and cook on high for 6 hours or until beans are tender.

A short supply cord is provided to reduce the hazards of becoming entangled in or tripping over a long cord. Extension cords may be used if care is exercised in their use. If an extension cord is used, the marked electrical rating of the detachable power-supply cord or extension cord should be at least as great as the electrical rating of the appliance. If the appliance is of the grounded type, the extension cord should be of a grounded 3-wire cord. The extension cord should be arranged so that it will not drape over the counter top or table top, where it can be pulled on by children or tripped over.

LIMITED WARRANTY

Toastess International warrants that this appliance shall be free from defects in material and workmanship for a period of one year from the date of purchase. During this 'in-warranty' period, defective products will be repaired or replaced at the discretion of the retailer and/or Toastess International. This warranty covers normal domestic usage and does not cover damage which occurs in shipment or failure which results from alteration, accident, misuse, abuse, glass breakage, neglect, commercial use or improper maintenance.

A defective product should be returned to the original place of purchase within the retailer's stipulated return/exchange period*. If you are unable to have a defective product replaced under warranty by the retailer, please check our website at "www.toastess.com" for the service centre nearest you or you may contact us for assistance by mail, e-mail, fax or telephone as listed below.

To ensure prompt 'in-warranty' service, securely package and return the product to us prepaid. Be sure to include the original proof of purchase and a description of the defect along with your address and zip/postal code.

For repairs not covered by the warranty, please contact us for assistance.

TOASTESS®

TOASTESS INTERNATIONAL

Customer Service Department
81A Brunswick
Dollard-des-Ormeaux
Québec, Canada H9B 2J5
E-mail: info@toastess.com
Fax: 514-685-8300
Tel: 514-685-2820

* Return/exchange policies at each retailer vary and may differ from the Toastess International 1 year limited warranty period.

Free Manuals Download Website

<http://myh66.com>

<http://usermanuals.us>

<http://www.somanuals.com>

<http://www.4manuals.cc>

<http://www.manual-lib.com>

<http://www.404manual.com>

<http://www.luxmanual.com>

<http://aubethermostatmanual.com>

Golf course search by state

<http://golfingnear.com>

Email search by domain

<http://emailbydomain.com>

Auto manuals search

<http://auto.somanuals.com>

TV manuals search

<http://tv.somanuals.com>