

Blender

USE AND CARE GUIDE

MODEL 1132



READ AND SAVE THESE INSTRUCTIONS

WARNING: A risk of fire and electrical shock exists in all electrical appliances and may cause personal injury or death. Please follow all safety instructions.

IMPORTANT SAFEGUARDS

When using electrical appliances, basic safety precautions should always be followed, including the following:

- ◆ Read all instructions before using blender.
- ◆ To protect against risk of electrical shock do not put blender motor base, cord or plug in water or other liquid. See instructions for cleaning.
- ◆ This blender is not for use by children.
- ◆ Close supervision is necessary when the blender is used near children.
- ◆ Unplug from outlet when not in use, before putting on or taking off parts, and before cleaning.
- ◆ Do not contact moving parts.
- ◆ Do not operate any blender with a damaged cord or plug or after the blender malfunctions, or has been dropped or damaged in any manner. Return blender to the nearest authorized service center for examination, repair, or electrical or mechanical adjustment.
- ◆ The use of attachments, including canning jars, not recommended by Toastmaster Inc., may cause a risk of injury to persons.
- ◆ Keep hands and utensils out of container while blending to reduce the risk of severe injury to persons or damage to the blender. A scraper may be used but must be used only when the blender is not running. Use a rubber spatula only.
- ◆ Blades are sharp. Handle carefully.
- ◆ To reduce the risk of injury, never place cutting blades on base without blender container properly attached.
- ◆ Screw on container bottom firmly. Injury can result if moving blades accidentally become exposed.
- ◆ Always operate blender with cover in place.
- ◆ Do not use outdoors or while standing in a damp area.
- ◆ Do not let cord hang over edge of table or counter, or touch hot surfaces.

- ◆ Do not leave blender unattended while it is operating.
- ◆ Do not use blender for other than intended use.
- ◆ Do not blend hot liquids.

SAVE THESE INSTRUCTIONS

CAUTION: A short power supply cord is provided to reduce the risk of personal injury resulting from becoming entangled in or tripping over a longer cord. Extension cords are available from local hardware stores and may be used if care is exercised in their use. If an extension cord is required, special care and caution is necessary. Also the cord must be (1) marked with an electrical rating of at least 125V. and 10 A., 1250 W., and (2) the cord should be arranged so that it will not drape over the countertop or tabletop where it can be pulled on by children or tripped over accidentally.

POLARIZED PLUG: This appliance has a polarized plug, (one blade is wider than the other). As a safety feature to reduce the risk of electrical shock, this plug is intended to fit in a polarized outlet only one way. If the plug does not fit fully in the outlet, reverse the plug. If it still does not fit, contact a qualified electrician. Do not attempt to defeat this safety feature.

This product is for household use only.

Note: Product may vary slightly from illustration.

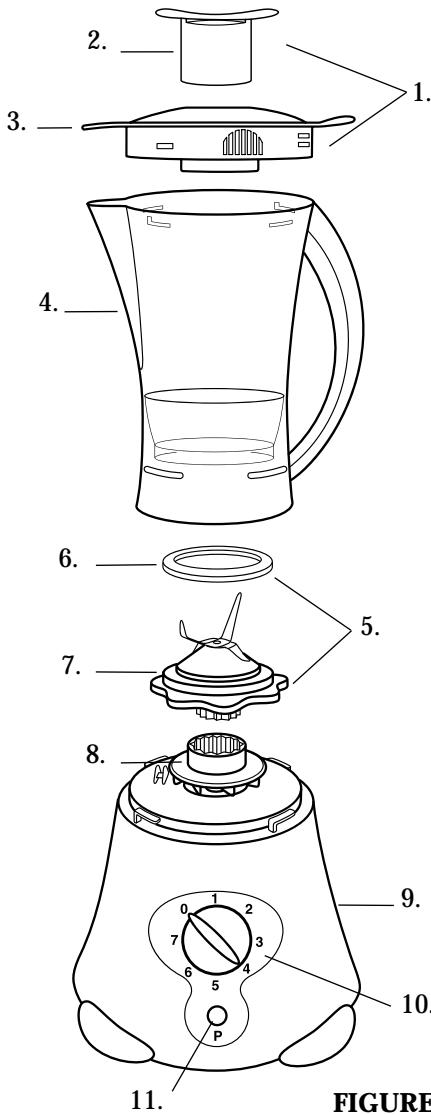

FIGURE 1

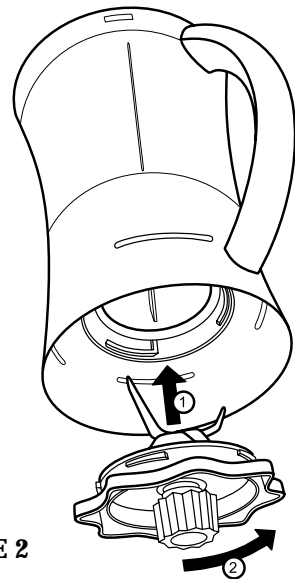

FIGURE 2



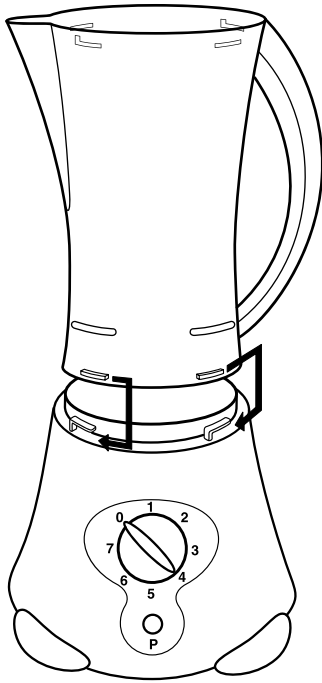

FIGURE 3

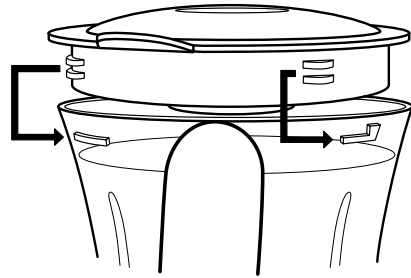

FIGURE 4

Using Your Blender

1. Before using your appliance for the first time and after each use, wash lid, measuring cup/lid insert, container, gasket and blades in warm sudsy water. Rinse and dry thoroughly. See CARE AND CLEANING.

CAUTION: BLADES ARE SHARP. HANDLE CAREFULLY.

CAUTION: NEVER PLACE BLENDER MOTOR BASE IN WATER OR OTHER LIQUIDS.

2. Place blender motor base on a dry level surface.
3. Make sure the knob is turned to OFF position, see FIGURE 1.

4. Invert container onto level countertop and assemble cutting assembly onto bottom of the container, making sure they are securely tightened into place, see FIGURE 2. Insert container until it fits securely into the blender motor base, aligning the notches and grooves, see FIGURE 3. Turn clockwise to lock.
5. Place food into container and cover with the lid assembly by turning counter-clockwise until locked into position, see FIGURE 4. Always hold onto container while blending. See DO and DO NOT instructions before using.

CAUTION: DO NOT ATTEMPT TO OPERATE WITHOUT LOCKING RING, BLADES, GASKET, CONTAINER LID, AND LID INSERT PROPERLY IN PLACE.

6. Plug unit into 120 V ~ 60 Hz a.c. outlet.
7. To start the blender, turn the speed control knob clockwise to any speed (1-7). Press the PULSE button to boost the speed at any time. *Note To use the "PULSE" action only, turn the speed control knob to OFF and press the pulse button for a few seconds. Release and repeat as necessary. The "PULSE" may be used for such food items as crumbling crackers, grating cheese or chopping vegetables.*
8. Turn knob to OFF position to stop action. Wait until blades stop rotating.
9. Unplug the appliance before removing container from the blender motor base.
10. Grasp container handle, turn container counter-clockwise and lift off of blender motor base. Remove lid assembly. Pour processed food out of the container. Unscrew locking ring from container and carefully remove cutting unit assembly. *Note: To serve beverages from the container, you may turn the lid assembly clockwise until it locks into place. This will position strainer above the pour spout.*

CAUTION: BLADES ARE SHARP. HANDLE CAREFULLY.

User Maintenance Instructions

This appliance requires little maintenance. It contains no user serviceable parts. Do not try to repair it yourself. Refer it to a qualified appliance repair technician if servicing is needed.

Care And Cleaning

1. Unplug the appliance.
2. Grasp container handle, turn counter-clockwise and lift off of blender motor base. Remove lid assembly and pour processed food out of container. Unscrew locking ring from container and carefully remove cutting assembly.

CAUTION: BLADES ARE SHARP. HANDLE CAREFULLY.

CAUTION: NEVER PLACE BLENDER MOTOR BASE IN WATER OR OTHER LIQUIDS.

3. Immediately after each use, disassemble lid and cutting assembly. Carefully wash all parts in warm sudsy water. Rinse and dry thoroughly. Do not wash parts in dishwasher.
4. Do not use a harsh abrasive on any part of the blender.
5. Clean exterior of blender motor base with a soft damp cloth and dry.
6. Reassemble cutting assembly onto container. Place onto blender motor base and cover with lid assembly. Spin dry on speed 7 for 10 seconds. Store with lid assembly ajar.

Any servicing requiring disassembly other than the above cleaning must be performed by a qualified appliance repair technician.

Do

- ◆ Always place liquid ingredients into the container first, unless recipe directs otherwise.
- ◆ Most foods require only seconds, not minutes, to process.
- ◆ Blend small amounts of solid food at a time for best results.
- ◆ Break or cut food into uniform 1"-2" size pieces and hard fibrous food into uniform ½" pieces before processing. This will allow the food to drop down around the blades for faster, more thorough blending action.
- ◆ Always place lid assembly on container before turning blender on to prevent splattering.
- ◆ To add foods while blender is operating, remove small clear insert on lid and slowly add ingredients.
- ◆ The removable lid insert may be used as a 2 oz. measuring device.
- ◆ Always remove bones, pits, hard shells, seeds, and cores before processing to avoid damaging the unit.
- ◆ If food sticks to sides of container and blending action stops, turn the unit off, remove the lid assembly and carefully push food down using a rubber spatula. Remove spatula, replace lid assembly and continue blending.
- ◆ If motor labors while processing, turn knob to higher speed or remove part of contents and blend in small batches.

Do Not

CAUTION: DO NOT ATTEMPT TO OPERATE WITHOUT THE LOCKING RING, BLADES, GASKET, CONTAINER, LID AND LID INSERT PROPERLY IN PLACE.

- ◆ Do not attempt to process extremely hard food which is difficult to cut with a kitchen knife.
- ◆ Do not fill the container with food above the 5 cup level.
- ◆ Do not store foods in the blender container.
- ◆ Do not process ice without liquids.
- ◆ Do not attempt to use the blender to mash potatoes, whip egg whites or cream, grind raw meat, knead heavy doughs, or extract juices from fruits and vegetables.
- ◆ Do not use the blender to process hot foods.
- ◆ Do not remove blender container from base or replace it until motor has stopped.
- ◆ Do not remove lid assembly while processing. Use removable insert on lid to add ingredients.



Blending Guide

Your blender features a variable speed control. While you may select any speed, the following list will help you determine where to set the control for various items.

SPEEDS	FOODS	MIXING PROCEDURES
1-2	Powdered Milk	Add water, then dry milk. Stir 15 seconds
	Frozen Juice	Add one 6 oz. can frozen juice, then water. Stir 15 seconds or until blended.
	Pancake Batter	Add liquid, eggs, then enough mix for 15 small pancakes. Stir 5 seconds. Stop and scrape sides. Stir 5 seconds more until large lumps disappear.
	Instant Pudding	Add milk then mix. Stir 30 seconds or until smooth.
	Malts	Add milk, flavoring and ice cream. Stir 15 seconds.
	Baby Food Vegetables	Cut into 1" pieces, simmer until tender, cool. Add ½ cup liquid and up to 1 cup cut-up food. Stir until desired texture.
	Fruit Toppings	Slightly thaw a 10 oz. package of frozen fruit. Place in a container and stir until desired consistency.
3-4	Bread	Tear 1 slice of bread into 6 pieces. Add to container. Chop for 5 seconds or until desired texture.
	Cookies	Break into 1" pieces and place up to 1 cup of food into container. Chop until desired consistency.

SPEEDS	FOODS	MIXING PROCEDURES
3-4	Crackers	Place up to 8 crackers in 2" squares into container. Chop until desired consistency.
	Chips & Cereal	Place up to 1 cup in container and chop until desired consistency.
	Fruit and Vegetables	Add up to 1 cup of food cut into ½" pieces and ½ cup water or other liquid to container. Chop 5 seconds or until desired consistency. Drain. (To chop dry, use PULSE).
	Cabbage	Coarsely dice cabbage and place up to 5 cups into container, fill with water. Chop for 5 seconds or until desired consistency. Drain thoroughly.
	Nuts	Place up to 1 cup into container and chop until desired consistency (or use PULSE).
5-6	Cheese-soft	Cut cheese into ½" cubes and place up to 1 cup into container. Chop 5-10 seconds or until desired consistency.
	Cheese-hard	Cut cheese into ½" cubes and place up to ½ cup into container. Chop 5-10 seconds or until desired consistency.
	Orange/Lemon Peel	Cut peel of one orange/lemon into 1" chunks. Chop 5-10 seconds or until desired consistency.
	Coffee Beans	Add up to ½ cup beans. Chop 45-90 seconds or until desired consistency.
	Chocolate Bars	Break 2 ounces into 1" pieces and chop 30-60 seconds or until desired consistency.

SPEEDS	FOODS	MIXING PROCEDURES
5-6	Creamed Soups Reconstitute	Add liquid, then soup. Mix 5 seconds or until smooth.
	Sauces	Add liquids then solids to container. Mix until desired consistency.
	Fruit	Cut fruit into ½” cubes and place up to 1 cup into container. Add ½ cup liquid. Mix 45-60 seconds or until desired consistency.
7	Salad Dressing	Add liquids then solids to container. Blend until desired consistency.
	Frozen Drinks	Place up to 2 cups of liquid then solid food into container. Blend 5-10 seconds then quickly drop 5-10 ice cubes, one at a time, through the lid insert. Immediately replace lid insert after each addition of ice cubes to prevent splattering.
	Vegetables	Place 1 cup of liquid and then add up to 1 cup of food cut into ½” cubes into container. Blend 30-60 seconds or until desired consistency.

Recipes

Beverages

Place all the ingredients in the container in the order listed. Cover and blend on speed 7 until smooth, from 15-60 seconds. Serve immediately. Each recipe makes 2-4 servings.

COTTAGE CHEESE COCKTAIL

1 cup chilled V-8® vegetable
juice
½ cup cottage cheese

CRANAPPLE COCKTAIL

1½ cups cold cranapple juice
2 TBL lemon juice
8-10 ice cubes, added one at a
time

BANANA SMOOTHIE

2 cups cold milk
2 ripe bananas
¼ tsp cinnamon
8-10 ice cubes, added one at a
time

MOCHA FRAPPE

1½ cups cold milk
2 tsp instant coffee
¼ tsp cinnamon
½ pint chocolate frozen yogurt

FRUIT SHAKE

1 cup ice cream
1 cup cold milk
1 cup frozen strawberries
(slightly thawed)
3 TBL powdered sugar

CHOCOLATE MILK SHAKE

2 cups cold milk
¼ cup chocolate syrup
1½ cups vanilla or chocolate
ice cream

PINEAPPLE JUICE

1 can (5¼ oz.) crushed
pineapple w/juice
1 cup cold milk
2 drops maple extract
8-10 ice cubes, added one at a
time

YOGURT PEACH SHAKE

1 cup frozen sliced peaches
w/juice (slightly thawed)
1 cup yogurt
1 TBL powdered sugar
sprinkle of cinnamon

CRANBERRY REFRESHER

1 cup cold cranberry juice
1 cup cold milk
2 TBL powdered sugar
¼ tsp vanilla

ORANGE FROSTY

1 can (6 oz.) frozen orange
juice concentrate
1 cup cold water
1 cup cold milk
½ cup sugar
1 tsp vanilla
8-10 ice cubes, added one at a
time



Salad Dressings

MAYONNAISE

1 egg
2 TBL vinegar
1 tsp sugar
½ tsp dry mustard
½ tsp salt
1 cup salad oil - divided

Place egg, vinegar, sugar, mustard, salt and ¼ cup of the oil into blender. Cover and mix on speed 5 or 6 until smooth, about 5 seconds. Without stopping blender, remove lid insert and gradually pour in remaining oil. Stop blender when all oil has been added. Makes 1¼ cups.

SANTA FE DRESSING

½ cup soy sauce
¼ cup lemon juice
¼ cup peanut oil
¼ cup olive oil
1 jalapeno pepper, cut into pieces
½ cup cucumber, cut into pieces
½ cup red onion, cut into pieces
8 cilantro sprigs

Place ingredients into blender in order listed. Cover and mix on speed 5 or 6 for 15-30 seconds or until smooth. Makes 2 cups.

SPICY COTTAGE CHEESE DRESSING

½ cup salad oil
8 oz. tomato juice
½ tsp Tabasco® pepper sauce
1 green onion, cut into pieces
1 cup cottage cheese

Place ingredients into blender in order listed. Cover and mix on speed 5 or 6 for 15-30 seconds or until smooth. Makes 1½ cups.

HIDDEN VALLEY DRESSING

½ cup milk
1 cup yogurt
1 pkg. (1.1 oz.) Original Hidden Valley Ranch® dressing
½ cup carrots, cut into pieces
½ cup cucumber, cut into pieces

Place ingredients into blender in order listed. Cover and mix on speed 5 or 6 for 15-30 seconds or until smooth. Makes 1½ -2 cups.

Salads

ITALIAN BEAN SALAD

- 1 can (15 oz.) butter beans, drained
- 1 can (15 oz.) kidney beans, drained
- 1 can (15 oz.) garbanzo beans, drained
- 1 can (15 oz.) black beans, drained

- ¼ cup sugar
- ¼ cup salad oil
- ½ cup vinegar
- ½ cup onion, cut into pieces
- ½ cup green pepper, cut into pieces
- ½ tsp mustard
- 1 tsp Italian seasoning

Combine drained beans in large bowl. Place remaining ingredients into blender in order listed. Cover and mix on speed 5 or 6 for 10-15 seconds or until large vegetables are chopped. Mix with beans and marinate in refrigerator several hours, stir occasionally. Makes 6 cups.

COLORFUL COLESLAW

- 4 cups cabbage, cored and cut into pieces
- 1 small red apple, cored and cut into pieces
- ⅓ cup salad oil
- 2 TBL lemon juice
- ½ TBL vinegar
- ¼ cup sugar
- 1 can (8 oz.) pineapple chunks with juice

Place cabbage and apple into blender, fill with water up to 5 cup mark. Chop on speed 3 or 4 for 15-25 seconds or until vegetables are coarsely chopped, drain thoroughly. Place remaining ingredients into container in order listed. Cover and mix on speed 5 or 6 for 5-10 seconds or until smooth. Stir into cabbage mixture and marinate in refrigerator a few hours, stir occasionally. Makes 4 cups.

CRANBERRY SALAD

- 1 small pkg. raspberry gelatin
- 1½ cups water
- ¼ cup sugar
- ½ cup walnuts
- 8 oz. fresh cranberries
- 2 cups apples, cored, cut into pieces

In a heat resistant 6" x 9" dish, add 1 cup boiling water to gelatin and sugar. Stir until dissolved. Add remaining ½ cup cold water. Place nuts in blender and chop on speed 3 or 4. Remove. Place 4 oz. of cranberries and one apple into blender, cover with water. PULSE until chopped. Drain thoroughly. Repeat with remaining cranberries and apples, reserving ½ cup of liquid. Stir in the ½ cup liquid, chopped cranberries and apples into gelatin. Chill.



Marinades

Place all ingredients into blender in order listed. Mix on speed 5 or 6 for 30 seconds. Coat meat, chicken or fish with mixture. Marinate in refrigerator at least 30 minutes. Quantities will marinate 1-1½ pounds of meat.

RED WINE

(Use with beef and lamb)

¼ cup red wine vinegar
2 TBL vegetable oil
1 TBL Dijon mustard
1 clove garlic
½ tsp dried Italian seasoning
⅛ tsp pepper, coarsely ground

CURRY YOGURT

(Use with chicken, lamb and pork)

⅓ cup plain yogurt
2 TBL lemon juice
1 TBL vegetable oil
2 cloves garlic
½ tsp curry powder
⅛ tsp crushed red pepper

LEMON ORIENTAL

(Use with chicken and fish)

¼ cup lemon juice
1 TBL soy sauce
1 TBL vegetable oil
¼ onion, cut into pieces
¼ tsp ground ginger
⅛ tsp crushed red pepper

SPICY HERB

(Use with any type of meat)

¼ cup dry wine
¼ cup vegetable oil
1 TBL lemon juice
¼ tsp Tabasco® pepper sauce
¼ onion, cut into pieces
1 clove garlic
⅛ tsp dried basil leaves
⅛ cup dry mustard

SZECHWAN

(Use with any type of meat)

¼ cup soy sauce
3 TBL dry sherry
¼ TBL sesame oil
2 TBL sugar
2 TBL corn starch

MEXICALI

(Use with any type of meat)

½ cup prepared salsa
2 TBL lime juice
1 TBL vegetable oil
2 TBL cilantro

Sauces

Dissolve flour in melted butter and pour into blender. Place remaining ingredients into container in order listed. Cover and chop on speed 3 or 4 for 10-15 seconds or until vegetables are chopped. Simmer sauce 5 minutes over low heat until thick. Makes 1½-2 cups. Serve with chicken or fish.

SALMON SAUCE

3 TBL butter, melted
3 TBL flour
1½ cups milk
2 TBL wine
2 TBL tomato paste
1 tsp thyme
1 clove garlic
½ cup onion, cut into pieces

DILL SAUCE

3 TBL butter, melted
3 TBL flour
1½ cups milk
2 TBL fresh dill
pinch nutmeg



Soups

VEGETABLE CREAM SOUP

¼ cup margarine
1 cup cauliflower, cut into pieces
1 cup broccoli, cut into pieces
¼ cup carrots, cut into pieces
¼ cup onion, cut into pieces

1 cup cold milk
½ cup chicken broth
1 cup cream

Melt butter in pan and saute vegetables until tender. Cool. Place milk, broth and vegetable mixture in blender. Cover and stir on speed 1 or 2 for 30-40 seconds or until smooth. Pour mixture back into pan, stir in cream and heat to simmer, stirring occasionally. Makes 3-4 servings.

CUCUMBER VICHYSOISE

2 cups cucumber, cut into pieces
½ cup onion, cut into pieces
2 cups chicken broth
½ tsp mustard
salt and pepper to taste

1 cup cold evaporated skim milk

Place vegetables, broth and seasonings in a pan. Cover and simmer 5 minutes or until tender. Cool. Place mixture into blender. Cover and mix on speed 5 or 6 for 30 seconds or until smooth. Chill thoroughly. When ready to serve, stir in milk. Makes 3-4 servings.

STEWED TOMATO SOUP

1 cup water
2 beef bouillon cubes
1½ cups V-8® juice
1 can (14 oz.) stewed tomatoes

Place ingredients into blender in order listed. Cover and mix on speed 5 or 6 for 30 seconds. Heat to a boil, stirring occasionally. Makes 3-4 servings.

GARDEN TOMATO SOUP

2 tsp corn starch
½ cup yogurt
1 TBL lime juice
1½ tsp sugar
1 green onion w/tops
3 medium tomatoes, quartered
salt and pepper to taste

Place ingredients into blender in order listed. Cover and mix on speed 5 or 6 for 30-45 seconds, or until smooth. Scrape sides if necessary. Heat to a boil, stirring occasionally. Makes 3-4 servings.

Desserts

CINNAMON PEACH COBBLER

¼ cup milk
2 TBL vegetable oil
¼ cup sugar
1 cup biscuit mix
(like Bisquick®)

1 can (21 oz.) peach pie filling
cinnamon for topping

Preheat oven to 350°F/177°C.

Place milk, oil, sugar and biscuit mix into blender in order listed. Cover and mix on speed 5 or 6 for 15-20 seconds, scrape sides if necessary. Remove batter through bottom of container after removal of cutting unit assembly.

FROZEN FRUIT CUPS

1 can (15¼ oz.) pineapple
chunks, with juice
1 banana, sliced
1 cup frozen strawberries
(slightly thawed)
½ cup sugar

Place ingredients into blender in order listed. Cover and stir on speed 1 or 2 for 30 seconds or until smooth. Pour into cups and freeze.

BLENDER BROWNIE

2 eggs
⅔ cup applesauce
1 tsp vanilla
¾ cup sugar
½ cup flour
¼ cup cocoa
½ tsp baking soda

powdered sugar

Preheat oven to 350°F/177°C.

Place ingredients into blender in order listed. Cover and mix on speed 5 for 15 seconds. Scrape sides and mix on speed 5 or 6 for 45-60 seconds. Pour into a greased 8" cake pan. Bake 45-50 minutes or until done. After cooled, dust with powdered sugar.



Pancakes

Preheat griddle or skillet. Place ingredients into blender in order listed. Cover and stir on speed 1 or 2 for 5 seconds, scrape sides and stir on speed 1 or 2 until large lumps disappear. Pour onto hot greased griddle. Cook on both sides until done.

COTTAGE CHEESE

4 eggs
1 cup cottage cheese
 $\frac{1}{2}$ tsp vanilla
 $\frac{1}{8}$ tsp salt
2 tsp vegetable oil
 $\frac{1}{2}$ cup flour
 $\frac{1}{2}$ tsp vanilla

SAUSAGE

$\frac{1}{4}$ cup milk
1 TBL vegetable oil
1 egg
 $\frac{1}{4}$ cup applesauce
4 oz. sausage cooked
and crumbled
 $\frac{1}{2}$ cup pancake mix

CHOCOLATE FUDGE

6 TBL water
2 TBL vegetable oil
1 egg
 $\frac{1}{4}$ tsp vanilla
2 TBL plus 2 tsp cocoa
 $\frac{1}{2}$ cup sugar
 $\frac{3}{4}$ cup biscuit mix
(like Bisquick®)

PEANUT BUTTER

$\frac{3}{4}$ cup milk
1 TBL vegetable oil
1 egg
2 TBL sugar
 $\frac{1}{4}$ cup peanut butter
1 cup pancake mix

Bread

FIESTA CORNBREAD

1 cup flour
 $\frac{1}{2}$ cup corn meal
 $\frac{1}{4}$ cup sugar
 $1\frac{1}{2}$ tsp baking powder
 $\frac{1}{4}$ tsp salt

 $\frac{3}{4}$ cup milk
3 TBL vegetable oil
4 oz. green chilies, drained
2 oz. pimienta, drained

Preheat oven to 375°F/190°C. Sift dry ingredients together in a bowl, set aside. Add liquid ingredients to blender in order listed. Cover and chop on speed 3 or 4 for 15-20 seconds or until chilies are chopped. Stir liquids into flour mixture. Spread into a greased 8" or 9" pan. Bake 25-30 minutes.

Meatloaf

Preheat oven to 350°F/177°C. Place bread into blender. Cover and chop on speed 3 or 4 for 5 seconds. Set aside. Place vegetables into blender, cover with water. Cover and PULSE for 20 seconds or until desired consistency. Drain thoroughly.

Place remaining ingredients, except meat and topping, into blender. Cover and mix on speed 5 or 6 or 6 for 5-10 seconds. Combine bread crumbs, vegetables, egg mixture and meat. Pat into 9" x 5" loaf pan. Place pan in center of oven. Bake for 1 hour 20 minutes or until done. Spread topping over meatloaf and bake for another 5-10 minutes.

PIZZA

1 slice bread torn into 6 pieces
½ cup onion, cut into pieces
1 cup catsup
1 egg
½ cup Parmesan cheese
2 tsp garlic salt
1 tsp pepper
2 tsp crushed oregano

2 lbs. ground turkey or lean
beef

Topping: ½ cup mozzarella
cheese

“SAUCY”

1 slice bread torn into 6 pieces
½ cup onion, cut into pieces
½ cup green pepper, cut into
pieces
1 egg
⅓ cup Heinz 57® sauce
salt and pepper to taste

2 lbs. ground turkey or lean
beef

Topping: 2 TBL Heinz 57®
sauce

FIESTA

1 slice bread torn into 6 pieces
½ cup celery, cut into pieces
¼ cup green pepper, cut into
pieces
¼ cup onion, cut into pieces
1 cup carrots, cut into pieces
1 egg
2 TBL steak sauce
salt and pepper to taste

2 lbs. ground turkey or lean
beef

Topping: 2 TBL steak sauce



LIMITED ONE YEAR WARRANTY

Warranty: This Toastmaster® product is warranted to be free from defects in materials or workmanship for a period of (1) year from the original purchase date. This product warranty covers only the original consumer purchaser of the product.

Warranty Coverage: This warranty is void if the product has been damaged by accident in shipment, unreasonable use, misuse, neglect, improper service, commercial use, repairs by unauthorized personnel, normal wear and tear, improper assembly, installation or maintenance abuse or other causes not arising out of defects in materials or workmanship. This warranty is effective only if the product is purchased and operated in the USA, and does not extend to any units which have been used in violation of written instructions furnished with the product or to units which have been altered or modified or to damage to products or parts thereof which have had the serial number removed, altered, defaced or rendered illegible.

Implied Warranties: ANY IMPLIED WARRANTIES WHICH THE PURCHASER MAY HAVE ARE LIMITED IN DURATION TO ONE (1) YEAR FROM THE DATE OF PURCHASE. Some states do not allow limitations on how long an implied warranty lasts, so the above limitation may not apply to you.

Warranty Performance: During the above one-year warranty period, a product with a defect will be either repaired or replaced with a reconditioned comparable model (at our option) when the product is returned to the Repair Center, or the purchase price refunded. The repaired or replacement product will be in warranty for the balance of the one-year warranty period and an additional one-month period. No charge will be made for such repair or replacement.

Service and Repair: Should the appliance malfunction, you should first call toll-free 1 (800) 947-3744 between the hours of 9:00 am and 5:00 pm Central Standard Time and ask for CONSUMER SERVICE stating that you are a consumer with a problem. Please refer to model number 1132 when you call.

In-Warranty Service (USA): For an appliance covered under the warranty period, no charge is made for service or postage. Call for return authorization (1 800 947-3744).

Out-of Warranty Service: A flat rate charge by model is made for out-of-warranty service. Include \$ 6.50 (U.S.) for return shipping and handling. We will notify you by mail of the amount of the charge for service and require you to pay in advance for the repair or replacement.

For Products Purchased in the USA, but Used in Canada: You may return the product insured, packaged with sufficient protection, and postage and insurance prepaid to the USA address listed below. Please note that all customs duty / brokerage fees, if any, must be paid by you and we will require you to pay the cost of customs duty / brokerage fees to us in advance of our performing any service.

Risk During Shipment: We cannot assume responsibility for loss or damage during incoming shipment. For your protection, carefully package the product for shipment and insure it with the carrier. Be sure to enclose the following items with your appliance: any accessories related to your problem, your full return address and daytime phone number, a note describing the problem you experienced, a copy of your sales receipt or other proof of purchase to determine warranty status. C.O.D. shipments cannot be accepted.

To return the appliance, ship to:

Attn: Repair Center
Toastmaster Inc.
708 South Missouri Street
Macon, MO 63552
Email: consumer_relations@toastmaster.com
www.toastmaster.com

To contact us, please write to or call:

Toastmaster Inc.
P.O. Box 6916
Columbia, MO 65205-6916
1 (800) 947-3744

Limitation of Remedies: No representative or person is authorized to assume for us any other liability in connection with the sale of our products. There shall be no claims for defects or failure of performance or product failure under any theory of tort, contract or commercial law including, but not limited to negligence, gross negligence, strict liability, breach of warranty and breach of contract. Repair, replacement or refund shall be the sole remedy of the purchaser under this warranty, and in no event shall we be liable for any incidental or consequential damages, losses or expenses. Some states do not allow the exclusion or limitation of incidental or consequential damages, so the above limitation or exclusion may not apply to you.

Legal Rights: This warranty gives you specific legal rights, and you may also have other rights which vary from state to state.

Keep Dated Sales Receipts for Warranty Service.

Keep this booklet. Record the following for reference:

Date purchased _____

Model number _____

Date code (stamped on bottom) _____

EVERYBODY EATS. It's a fact of life.

**But sometimes preparing
meals can become a chore.**

**That's why TOASTMASTER has been invited
into millions of kitchens just like yours
so we can HELP YOU MASTER your
mixing, baking, grilling, toasting,
brewing, heating and serving
tasks WITH EASE AND STYLE.**

**The TOASTMASTER name stands for a
CELEBRATION of INNOVATION designed
to serve your life and keep you
COOKIN' IN STYLE.**



toastmaster®

21.

Blendtec

USE AND CARE GUIDE

MODEL 1132



- Powerful 350-watt motor
- 8 speeds including Pulse
- Stainless steel blades
- Handy measuring cup inside lid
- Durable 48 oz. container

Questions
Call free 1-800-947-3744



Free Manuals Download Website

<http://myh66.com>

<http://usermanuals.us>

<http://www.somanuals.com>

<http://www.4manuals.cc>

<http://www.manual-lib.com>

<http://www.404manual.com>

<http://www.luxmanual.com>

<http://aubethermostatmanual.com>

Golf course search by state

<http://golfingnear.com>

Email search by domain

<http://emailbydomain.com>

Auto manuals search

<http://auto.somanuals.com>

TV manuals search

<http://tv.somanuals.com>