

Rachael Ray



***FOOD PROCESSOR***  
***OWNER'S MANUAL***  
***Model RRFP1***

# IMPORTANT SAFEGUARDS

When using electrical appliances, basic safety precautions should always be followed, including the following:

1. Read all instructions.
2. To protect against risk of electrical shock, do not put cord, plug, or appliance in water or other liquid.
3. Close supervision is necessary when any appliance is used by or near children.
4. Unplug from outlet when not in use, before putting on or taking off parts, and before cleaning.
5. Avoid contacting moving parts.
6. Do not operate any appliance with a damaged cord or plug or after the appliance malfunctions, or is dropped or damaged in any manner. Contact Consumer Service for examination, repair or electrical or mechanical adjustment.
7. The use of attachments not recommended or sold by the manufacturer may cause fire, electric shock or injury.
8. Do not use outdoors.
9. Do not let cord hang over edge of table or counter.
10. Do not let cord contact hot surface, including the stove.
11. Keep hands and utensils away from moving blades or discs while processing food to reduce the risk of severe injury to persons or damage to the Food Processor. A scraper may be used, but must be used only when the Food Processor is not running.
12. Blades are sharp. Handle carefully.
13. To reduce the risk of injury, never place cutting blade or discs on base without first putting bowl properly in place.
14. Be certain Cover is securely locked in place before operating appliance.
15. Never feed food by hand. Always use food pusher.
16. Do not attempt to defeat the cover interlock mechanism.

## SAVE THESE INSTRUCTIONS

**FOR HOUSEHOLD USE ONLY.**

# Additional Important Safeguards

1. All users of this appliance must read and understand this Owner's Manual before operating or cleaning this appliance.
2. The cord to this appliance should be plugged into a 120V AC electrical outlet only.
3. Do not leave this appliance unattended during use.
4. If this appliance begins to malfunction during use, immediately turn the unit OFF and unplug the cord. Do not use or attempt to repair the malfunctioning appliance.
5. If this appliance falls or accidentally becomes immersed in water, unplug it immediately. ***Do not reach into the water!*** Do not use this appliance after it has fallen into or becomes immersed in water.
6. To reduce the risk of injury to persons or property, never use this appliance in an unstable position.
7. Do not use this appliance for other than its intended use.

## Polarized Plug

This appliance has a polarized plug (one blade is wider than the other). To reduce the risk of electric shock, this plug is intended to fit into a polarized outlet only one way. If the plug does not fit fully in the outlet, reverse the plug. If it still does not fit, contact a qualified electrician. Do not attempt to modify the plug in any way.

## Electric Power

If the electrical circuit is overloaded with other appliances, your appliance may not operate. It should be operated on a separate electrical circuit from other appliances.

## Plasticizer Warning

**CAUTION:** To prevent Plasticizers from migrating from the finish of the countertop or tabletop or other furniture, place **NON-PLASTIC** coasters or placemats between the appliance and the finish of the countertop or tabletop.

**Failure to do so may cause the finish to darken, permanent blemishes may occur or stains can appear.**

# Getting to Know Your Rachael Ray RRFP1 Food Processor

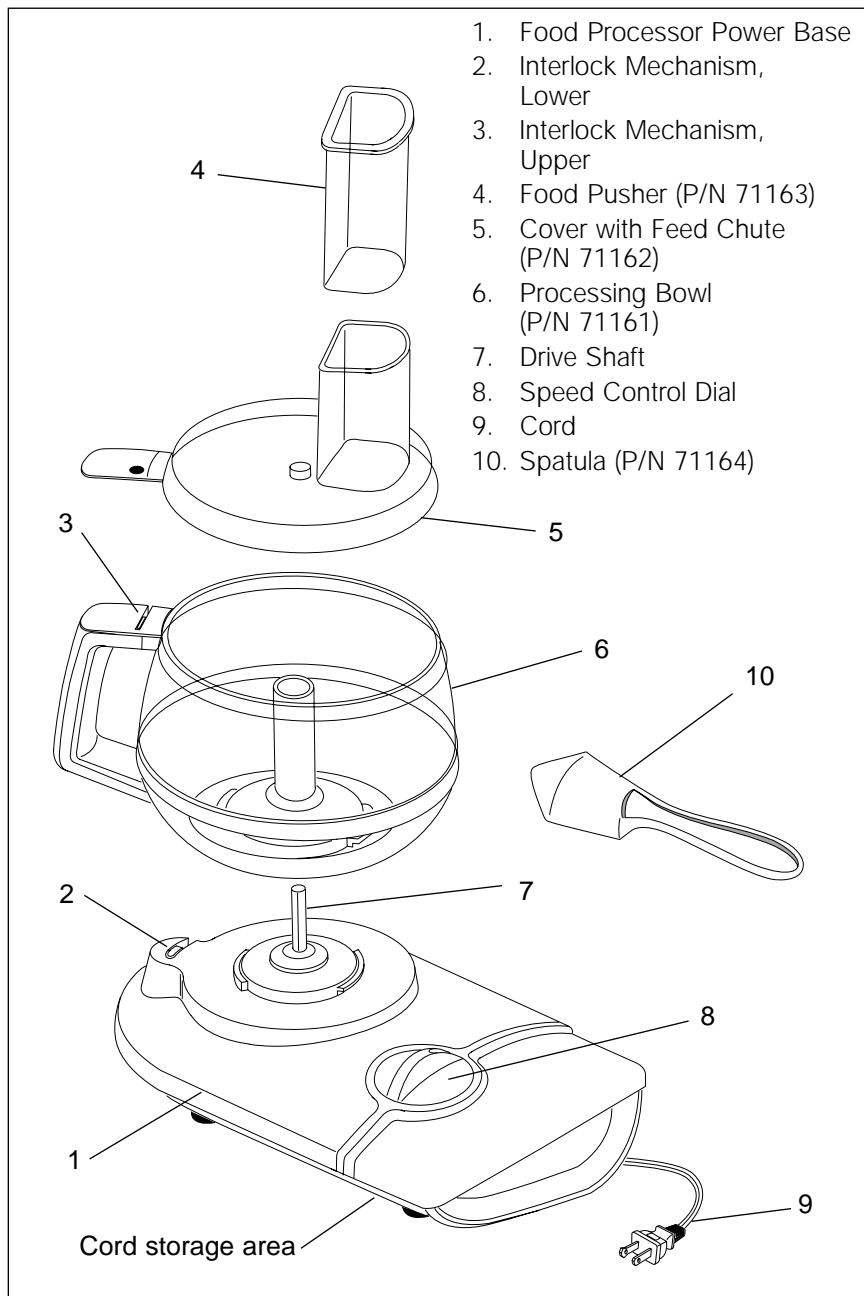

# Getting to Know Your RRF1 Attachments

11. **Chopping Blade** (P/N 71165)  
Stainless steel blade designed for cutting and kneading.

12. **Shredding/Grating Blade 'F'** (P/N 71166)  
Stainless steel shredding blade, fine.

13. **Shredding Blade 'C'** (P/N 71167)  
Stainless steel shredding blade, coarse.

14. **Slicing Blade 'F'** (P/N 71168)  
Stainless steel slicing blade, fine.

15. **Slicing Blade 'C'** (P/N 71169)  
Stainless steel slicing blade, coarse.

16. **Blade Holder** (P/N 71170)  
Designed to hold a Shredding or Slicing Blade, with finger holes.

17. **Blade Holder Stem** (P/N 71183)  
Fits over Drive Shaft to support Blade Holder.

## CONTROL DIAL with Indicator Light

**P** - Pulse  
**OFF**  
**1** - Low Speed  
**2** - High Speed

# Before First Use

**WARNING: Blade Attachments are very sharp. Use extreme care when handling Blades. Failure to do so can result in personal injury.**

1. Carefully unpack the Food Processor and wash the Processing Bowl, Cover with Feed Chute, Food Pusher, Spatula and attachments in warm soapy water. Rinse and dry thoroughly.
2. Wipe the Food Processor Power Base with a soft, moistened cloth. **Never immerse the Food Processor Power Base in water or any other liquid.**

## Assembly Instructions

1. Before assembling the Food Processor ensure that the Cord is unplugged.
2. Place the Food Processor Power Base facing you on a dry, level surface.
3. Place the Processing Bowl onto the Power Base. The Bowl will only sit correctly when the handle is positioned to the left at the ten o'clock position.
4. Turn the Processing Bowl counter clockwise to engage the locking tabs and the Power Base Interlock Mechanism.
5. Determine which processing blade is to be used; Chopping, Shredding or Slicing. If shredding or slicing, insert the appropriate blade into the top side of the Blade Holder, making sure it snaps in place. See illustration.

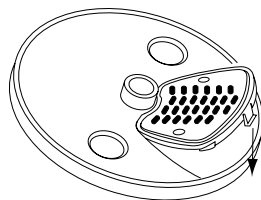
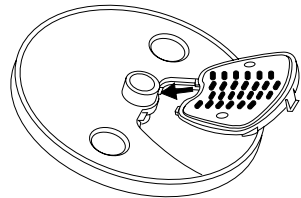
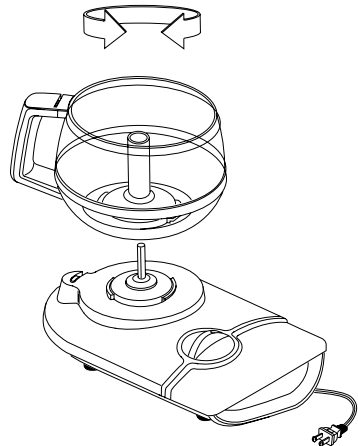

# Assembly Instructions (Cont.)

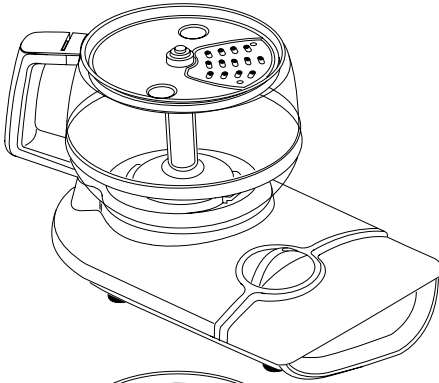

6. Insert the attachment of choice in the Processing Bowl over the Drive Shaft. When using the Blade Holder, slip the Blade Holder Stem over the Drive Shaft, then grasp the Blade Holder, using the finger holes, and insert over the Drive Shaft.

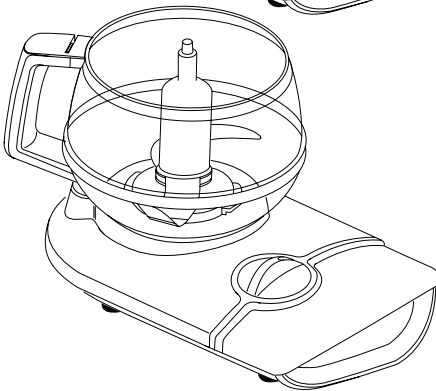

7. Place the Cover on the Processing Bowl with the locking extension at approximately the nine o'clock position. Rotate the Cover counter clockwise to engage the locking tabs and the Upper Interlock Mechanism in the Processing Bowl handle.

**Note:** If the Processing Bowl and the Cover are not correctly assembled, the Upper and Lower Safety Interlock Mechanism will not be closed and the Food Processor will not function.

8. Insert the Food Pusher in the Feed Tube on the Cover.
9. Make sure the Speed Control knob is in the OFF position, then plug the Cord into a 120V AC power outlet.
10. The Food Processor is now ready to begin use.

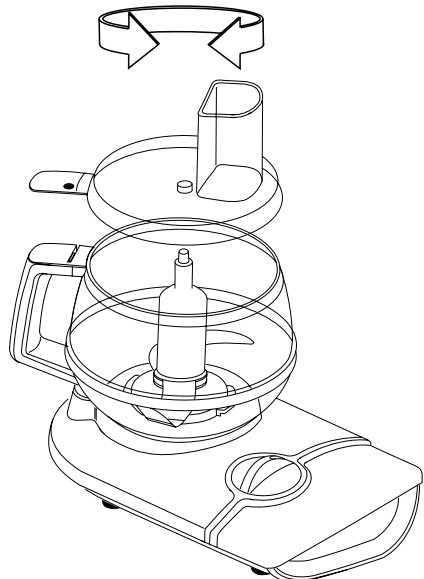



# Instructions for Use

## Slicing and Shredding

**CAUTION:** Always unplug Food Processor from outlet before installing or removing attachments.

**CAUTION:** Use extreme care when handling the Slicing/Shredding Blades. Do not touch the cutting edges with your fingers. The cutting edges are very sharp and can cause injury if touched.

1. Make sure the unit is unplugged. Attach the Processing Bowl to the Power Base. See Assembly Instructions for details.
2. Insert a Slicing or Shredding Blade into the Blade Holder. See Assembly Instructions for specific details.
3. Insert the Blade Holder and Stem in the Processing Bowl over the Drive Shaft.
4. Place the Cover on the Processing Bowl with the locking extension at approximately the nine o'clock position. Turn the Cover counter clockwise to engage the locking tabs and the Upper Interlock Mechanism in the Processing Bowl handle.

**Note:** If the Processing Bowl and the Cover are not correctly assembled, the Upper and Lower Safety Interlock Mechanism will not be closed and the Food Processor will not function.

5. Make sure unit is in the OFF position; then plug the Food Processor into a 120V AC electrical outlet.
6. Remove the Food Pusher and insert the food to be processed into the Feed Chute (see Food Processing Hints for food preparation details). Turn the Speed Control Dial to desired speed; the Indicator Light will come on. Use even, constant pressure on the Food Pusher to feed food into the Feed Chute. If processing slows or seems labored, increase the Speed Control Dial from 1 to 2 or turn to OFF and select the Pulse setting. **Note:** Do not use excessive force or you will damage the Food Processor.

**Caution:** Never use fingers or other utensils to push food down the Feed Chute. Always use the Food Pusher.

7. When finished processing, move the Speed Control Dial to OFF, the Indicator Light will go off, and unplug the unit.  
**Note:** This Food Processor is equipped with an automatic brake that will stop the rotation of the Blade within seconds. Although this automatic brake provides an additional measure of safety, make sure that the Blade has completely stopped before you remove the Cover or unplug the unit.
8. Turn the Cover clockwise to disengage the locking tabs and lift the Cover from the Processing Bowl.
9. Carefully lift the Blade Holder Assembly from the Processing Bowl using the finger holes. Remove the Blade Holder Stem.
10. Turn the Processing Bowl handle clockwise to disengage the locking tabs and lift the bowl from the Power Base.
11. Remove contents from the Processing Bowl and the Blade Holder Assembly with the Spatula.

# Instructions for Use (Cont)

## Chopping

**CAUTION:** Always unplug Food Processor from outlet before installing or removing attachments.

**CAUTION:** Use extreme care when handling the Chopping Blade. Do not touch the cutting edges with your fingers. The cutting edges are very sharp and can cause injury if touched.

1. Make sure the unit is unplugged. Attach the Processing Bowl to the Power Base. See Assembly Instructions for details.
2. Insert the Chopping Blade in the Processing Bowl over the Drive Shaft.
3. Place up to 8 cups of the food to be chopped into the Processing Bowl (see Food Processing Hints for food preparation details).
4. Place the Cover on the Processing Bowl with the locking extension at approximately the nine o'clock position. Turn the Cover counter clockwise to engage the locking tabs and the Upper Interlock Mechanism in the Processing Bowl handle.

**Note:** If the Processing Bowl and the Cover are not correctly assembled, the Upper and Lower Safety Interlock Mechanism will not be closed and the Food Processor will not function.

5. Make sure unit is in the OFF position; then plug the Food Processor into a 120V AC electrical outlet.
6. Turn the Speed Control Dial to the desired speed setting. The Indicator Light will come on. If processing slows or seems labored, increase the Speed Control Dial from 1 to 2 or turn to OFF and select the Pulse setting. Additional ingredients may be added through the Feed Chute while processing.

**Caution:** Never use fingers or other utensils to push food down the Feed Chute. Always use the Food Pusher.

7. When finished processing, move the Speed Control Dial to OFF, the Indicator Light will go off, and unplug the unit.

**Note:** This Food Processor is equipped with an automatic brake that will stop the rotation of the Blade within seconds. Although this automatic brake provides an additional measure of safety, make sure that the Blade has completely stopped before you remove the Cover or unplug the unit.

8. Turn the Cover clockwise to disengage the locking tabs and lift the Cover from the Processing Bowl.
9. Carefully lift the Chopping Blade from the Processing Bowl.
10. Turn the Processing Bowl handle clockwise to disengage the locking tabs and lift the bowl from the Power Base.
11. Remove contents from the Processing Bowl and the Chopping Blade with the Spatula.

# Slicing, Shredding and Chopping Guide

<b>SLICING BLADE - Cut food to fit Chute, use Speed 1</b>	
<b>FOOD</b>	<b>BLADE</b>
Apple	Coarse
Cabbage/Lettuce	Coarse
Carrots	Fine or Coarse
Celery	Fine or Coarse
Cucumber	Fine or Coarse
Mushrooms	Fine or Coarse
Onions	Fine or Coarse
Peppers	Fine or Coarse
Potatoes	Fine or Coarse
Summer Squash	Fine or Coarse

<b>SHREDDING BLADE - Cut food to fit Chute, use Speed 1</b>	
<b>FOOD</b>	<b>BLADE</b>
Apple	Coarse
Carrots	Coarse
Cheese, hard Parmesan, Romano	Fine or Coarse
Cheese, soft or semi-soft Cheddar, mozzarella, Swiss	Coarse
Summer Squash	Coarse

<b>CHOPPING BLADE - Push food from sides of bowl with spatula when necessary</b>	
<b>FOOD</b>	<b>SPEED</b>
Apple	Pulse
Bread	1 or 2
Cabbage	1 or 2
Carrots	1 or 2
Celery	Pulse
Crackers	1 or 2
Eggs, hard boiled	Pulse
Garlic	Pulse
Mushrooms	Pulse
Onions	Pulse
Parsley or other Herbs	1 or 2
Peppers	Pulse
Potatoes	Pulse
Walnuts	Pulse

# Food Processing Hints

- **Chopping** - For best results, cut or tear food into pieces approximately equal in size before processing. The finished results will be more uniform. Consistent processing results are achieved if the container has 2 to 8 cups of fruits or vegetables.
- **Mincing** - Pre-cooked meat into cubes approximately 1-inch square.
- **Fruits and Vegetables** - Before processing fruits and vegetables, clean and cut into 1-inch pieces.
- **Mixing** - Quantities that can be processed within the Processing Bowl will vary depending upon the density of the ingredients being used.
- **Adding Ingredients** -Liquid ingredients may be added while the processor is operating by pouring through the Feed Tube in the Cover.
- **Using the Feed Tube** - The most important factor for successful slicing and shredding is the way in which the food is packed into the Feed Tube. The Feed Tube should always be packed firmly to allow each piece of food to support the others. There will always be a small portion of food left unprocessed between the Food Pusher and the Blade.

**Caution:** Never use fingers or other utensils to push food down the Feed Chute. Always use the Food Pusher.

- **Slicing and Shredding** - Cut all ingredients to a size that fits comfortably into the Feed Tube. Pack the Feed Tube and, while holding food steady and upright with the Food Pusher, press down evenly until all ingredients are sliced or shredded. Do not use excessive force or you may damage the Food Processor.

**Long Slices:** Pack food items horizontally in Feed Tube.

**Short Slices:** Pack food items vertically in Feed Tube.

**Shredding:** For best results remember that softer foods such as cheese (Cheddar, mozzarella or Swiss) should be well chilled before processing. Harder foods such as Parmesan or Romano cheese should be at room temperature before processing. **Note:** When grating Parmesan cheese do not apply excessive pressure to the Food Pusher.

# User Maintenance Instructions

This appliance requires little maintenance. It contains no user-serviceable parts. Any servicing requiring disassembly other than cleaning must be performed by a qualified appliance repair technician.

**CAUTION: The Blades are sharp! Handle with care! Use extreme care when handling the Blades. Do not touch the Blades with your fingers. The Blades are very sharp and can cause injury if touched.**

**CAUTION: Never place Processor Power Base in water or any other liquid.**

1. Always unplug the unit before cleaning. Make sure the Chopping Blade or Blade Holder Assembly has completely stopped before any disassembly.
2. Remove all attachments.
3. Wash the Processor Bowl, Lid with Feed Chute, Food Pusher, Blade Holder, Blade Holder Stem, Slicing/Shredding Blades, Chopping Blade and Spatula in warm soapy water. Removable parts may also be cleaned in the dishwasher. Load parts on the top rack away from the dishwasher heating coil.
4. **Never immerse the Processor Power Base in water or any other liquid.** If necessary, wipe exterior surface with a soft, damp cloth or sponge and dry thoroughly.

## Storage

Unplug and clean the unit. Push the cord into the Cord Storage area located on the underside of the appliance. Never wrap the cord around the appliance. The appliance should be stored in a clean, dry place.



## Recipes

This recipe has been specially created by Rachael Ray for this appliance.

### BASIL-TARRAGON PESTO

For 2 pounds of pasta, such as fettuccine

2 bunches, about 2 cups, fresh basil leaves

1/2 cup tarragon leaves stripped from stems, about 5 - 6 sprigs

4 small cloves of garlic, popped from skins

6 tablespoons pine nuts, a handful

1/4 pound, about 1 cup, grated Parmigiano Reggiano cheese, a couple handfuls

The zest of 2 lemons

2 splashes of water, about 2 tablespoons

1/2 cup EVOO - extra virgin olive oil, eyeball it

Coarse salt and fresh black pepper, to your taste

Place the basil, tarragon, garlic, pine nuts, cheese and lemon juice in processor and pulse grind to a fine chop. Add a couple splashes of water and turn processor on. Stream the EVOO into the processor to form a thick sauce. Season sauce with salt and pepper to taste and scrape into a large shallow serving bowl.

Cook the pasta in salted boiling water. Drain pasta and add hot pasta to sauce. Toss to coat evenly and adjust seasoning. Serve immediately.

**Yield:** 8 servings or 1 1/4 cups



These recipes have been specially created by Rachael Ray for this appliance.

## CLASSIC BASIL, PARSLEY AND SPINACH-WALNUT PESTOS

Each pesto recipe will provide enough sauce for 2 pounds of pasta, or freeze some and have it next week.

### Method for each recipe:

- Toast pine nuts (pignoli), walnuts or sesame seeds until golden brown before using them. (Buy nuts a handful at a time from the bulk bins.)
- Heat oil and garlic in small pan on low heat or in microwave, 30 seconds on high, before using.
- Pulse all ingredients in processor until paste forms.
- Serve over hot pasta, but never heat the pestos themselves. Pestos should be used at room temperature.

### CLASSIC BASIL PESTO

- 1 cup EVOO - extra virgin olive oil
- 4 cloves garlic, popped from skin and cut in half
- 1/2 pound, about 2 3/4 cups, grated Parmigiano Reggiano cheese, a couple of handfuls
- 6 ounces pine nuts (a handful)
- 2 bunches basil, about 80 to 100 leaves or 2 cups

### PARSLEY PESTO

- 1 cup EVOO - extra virgin olive oil
- 4 cloves garlic, popped from skin and cut in half
- 1/2 pound, about 2 3/4 cups, grated Parmigiano Reggiano or Romano cheese, a couple of handfuls
- 6 ounces walnut pieces (a handful)
- 2 bunches fresh flat-leaf parsley, tops ripped away from stems

### SPINACH-WALNUT PESTO

- 1 cup EVOO - extra virgin olive oil
- 4 cloves garlic, popped from skin and cut in half
- 2 cups fresh spinach leaves, packed down, or 1 cup drained, defrosted frozen chopped spinach
- 6 ounces walnut pieces (a handful)
- 4 pinches ground nutmeg
- 1/2 pound, about 2 3/4 cups, grated Parmigiano Reggiano or Romano cheese, a couple of handfuls



## Recipes (Cont.)

These recipes have been specially created by Rachael Ray for this appliance.

### TEX-MEX WHITE BEAN DIP

3 cans (14 ounces) white kidney or cannelloni beans, drained  
3 cloves garlic, popped away from skin  
6-9 tablespoons fresh cilantro, a couple of handfuls of leaves  
4 1/2 teaspoons ground cumin, a palm full  
2 tablespoons hot sauce, such as Tabasco®, eyeball it  
3 splashes of water, about 3 tablespoons  
Coarse salt and fresh black pepper, to your taste  
Corn tortilla chips, yellow or blue, any variety and salsa of your choice

Place the beans, garlic, cilantro, cumin, and Tabasco® in processor. Process the beans until smooth on speed 2. If dip is too thick, add water a splash at a time and reprocess. Season the dip with salt and pepper to taste. Serve with chips and salsa.

**Yield:** 3 1/2 cups

### MUFFALETTA SANDWICH RELISH

Spread this on your favorite sub or Italian sandwich - WOW!

20 large pitted green olives with pimientos, drained about 1 cup  
1 (16 ounce) jar, Giardiniera, Italian pickled vegetable salad, drained  
(*Giardiniera is a pickled veggie mixture of cauliflower, carrots, celery and hot peppers*)  
A handful of flat-leaf parsley leaves  
A handful of fresh basil leaves  
The zest of 1 lemon and juice of 1/2 lemon

Place all the ingredients in processor and Pulse to form a finely chopped relish. Transfer to a small container and keep on hand for spreading on your favorite sandwiches.

**Yield:** 2 cups





This recipe has been specially created by Rachael Ray for this appliance.

## ITALIAN ROASTED RED PEPPER HUMMUS

- 2 (14 ounces) cans chick peas (garbanzo beans), drained
- 4 roasted red peppers, or 1 (15 ounce) jar roasted bell peppers, drain and pat dry
- 2 sprigs fresh rosemary leaves stripped from stems
- 2 cloves garlic, cracked away from skin
- 4 pinches of crushed red pepper flakes
- 2 splashes of water, about 2 tablespoons
- 4-6 tablespoons EVOO - extra virgin olive oil, eyeball it
- Salt and pepper, to taste
- Specialty potato chips, sesame melba rounds, or toasted bread rounds for dipping

Place chick peas, red peppers, rosemary, garlic, and red pepper flakes in processor and grind on Speed 2 into a thick paste. Add water a splash at a time and reprocess. While processor is on, stream in EVOO to form a smooth dip. Season the dip with salt and pepper, to your taste. Transfer dip to a small bowl and serve with dippers of choice.

**Yield:** 4 cups



## Recipes (Cont.)

This recipe has been specially created by Rachael Ray for this appliance.

### GREEN WRAPS WITH WHITE BEAN HUMMUS

2 (15 ounce) cans cannelloni beans, drained and rinsed  
4 stems fresh rosemary, leaves stripped from stem  
2 cloves garlic, popped from skin  
3-4 tablespoons EVOO - extra virgin olive oil, eyeball it  
Black pepper, to your taste

4 firm vine-ripened tomatoes, thinly sliced  
1/2 seedless cucumber, thinly sliced  
1/2 red onion, thinly sliced  
A couple handfuls pitted Kalamata olives  
A couple of handfuls chopped fresh flat-leaf parsley  
1/2 pound mixed greens  
2 lemons  
EVOO - extra virgin olive oil  
Coarse salt, to taste  
1/2 pound feta cheese, crumbled

8 large pita breads, or flour tortilla wraps, or flavored wraps

Combine beans, rosemary, garlic, EVOO, and black pepper in processor. Pulse until mixture is smooth.

Combine tomatoes, cucumber, onion, olives, parsley, greens, and the juice of lemons in a bowl. Drizzle with olive oil, and sprinkle with salt. Combine well.

Warm pitas or wraps in microwave oven or on a griddle pan. Spread with a generous dose of white bean hummus. Top with a layer of Greek salad mixture. Sprinkle with Feta cheese crumbles and roll. Wrap lower half of wraps with foil or waxed paper to keep it together while you eat your way down. Keep a paper towel in your hand as you eat to catch any drips. Batches of white bean spread are also a terrific dip for specialty chips, celery, or bread sticks.

**Yield:** 8 wraps

## **SPINACH DIP**

- 1 (10 ounce) package, defrosted frozen chopped spinach
- 1 (8-ounce) can sliced water chestnuts, drained
- 2 cloves garlic
- 1 cup plain yogurt
- 2 bunches green onions, cut in 1-inch pieces
- 1 cup sour cream
- 2 teaspoons salt
- 1 teaspoon dried tarragon leaves
- 1/2 teaspoon dry mustard
- 1/2 teaspoon pepper

Place all of the ingredients into the Food Processor with the Chopping Blade. Chop on Speed 2 until blended. Remove from the Bowl, cover and refrigerate for 2 hours to enhance flavor.

**Yield:** 4 cups

## **CRAB DIP**

- 1 (8 ounce) container lump crab meat
- 1 medium cucumber peeled, cut in half and seeded, cut in 1-inch pieces
- 11 ounces cream cheese, softened
- 1/3 cup mayonnaise
- 2 teaspoons chili sauce
- 2 teaspoons Worcestershire sauce
- 1/8 teaspoon sugar
- 3/4 teaspoon Old Bay seasoning
- Salt and pepper to taste

Add all ingredients to the Food Processor with the Chopping Blade. Pulse until ingredients are chopped and mixed. Remove from the Bowl, cover and refrigerate for 2 hours to enhance flavor.

**Yield:** 4 cups

## **PIMENTO CHEESE SPREAD**

- 1 (16 ounces) block Cheddar cheese
- 1 (4 ounce) jar pimentos, drained
- 2 cups salad dressing

Use the Coarse Shredding Blade to shred the cheese then remove from the bowl. Place the Chopping Blade into the Bowl and add the pimentos, salad dressing and cheese. Process the mixture on Speed 1 until blended. Remove from the Bowl, cover and refrigerate for 2 hours.

**Yield:** 4 cups

# Recipes (Cont.)

## FRESH SALSA

- 10 Roma tomatoes, quartered and seeds removed
- 1 medium jalapeno pepper, halved and seeds removed
- 1 large onion, cut into 1-inch cubes
- 1/2 cup packed fresh cilantro leaves stripped from the stems
- 1 teaspoon cider vinegar
- 1 teaspoon salt
- 1/2 teaspoon black pepper

Place all of the ingredients into the Food Processor with the Chopping Blade. Pulse until coarsely chopped. Remove from the Bowl, cover and refrigerate for 2 hours.

**Yield:** 3 cups

## PEANUT BUTTER

- 12 ounces cocktail party peanuts
- 3 tablespoons honey
- 1/2 teaspoon cinnamon

Place all of the ingredients into the Food Processor with the Chopping Blade. Chop on Speed 2 until smooth. Remove from the Bowl and serve. Store in the refrigerator to keep fresh.

**Yield:** 1 1/2 cups

## BRUSCHETTA

### **Topping:**

- 8 Roma tomatoes, quartered and seeds removed
- 1/4 cup packed fresh basil leaves, about 15
- 1/2 medium onion, cut into 1 inch cubes
- 3 cloves garlic
- 2 tablespoons olive oil
- 1 teaspoon red wine vinegar
- 1/2 teaspoon salt
- 1/4 teaspoon black pepper

### **Bread:**

- 1 loaf French Baguette or crusty Italian bread cut diagonally in 1/2 inch slices
- 2 teaspoons garlic salt
- 3/4 cup olive oil

Place all of the topping ingredients into the Food Processor with the Chopping Blade. Pulse until coarsely chopped. Remove from the Bowl to serve on warm grilled bread.

Mix together olive oil and garlic salt. Brush both sides of the sliced bread with the oil mixture. Lightly brown both sides of the bread. Top warm bread with Bruschetta and serve.

**Yield:** 3 cups bruschetta

# Recipes (Cont.)

## MEATBALLS

1 pound tenderized stew meat  
1 slice bread, tear in 1-inch pieces  
1 small onion, cut in 1-inch pieces  
1 clove garlic  
1 egg  
1/2 teaspoon dried thyme  
Salt and pepper to taste  
1/2 cup all-purpose flour

Place all of the ingredients, except flour, into the Food Processor with the Chopping Blade. Chop on Speed 2 until meat is ground and ingredients are mixed together. DO NOT over process.

Shape into 2-inch meatballs and coat with flour. Heat oil in skillet and cook meatballs until done.

**Yield:** 12 meatballs

## MACARONI SALAD

3 cups uncooked elbow macaroni  
1 tablespoon vegetable oil  
1/2 onion, cut in 1-inch cubes  
2 stalks celery, cut in 1-inch pieces  
1 carrot, cut in 1-inch pieces  
1/2 green pepper, cut in 1-inch pieces  
3 hard-boiled eggs, cut in half

### DRESSING:

1 1/3 cups sugar  
1/2 cup vinegar  
2 eggs  
1 1/2 teaspoons salt  
1 cup salad dressing  
1 1/2 teaspoons prepared mustard  
1 (5 1/3-ounce) can evaporated milk

Cook macaroni, drain and stir in oil. Place the onion, celery, carrot, green pepper and hard-boiled eggs into the Food Processor with the Chopping Blade. Pulse the food until coarsely chopped, stir into the cooked macaroni.

To make dressing, combine sugar, vinegar, eggs and salt. Bring to a boil over medium heat, stirring frequently. Cool and stir in rest of dressing ingredients. Pour over macaroni mixture, refrigerate several hours.

**Yield:** 12 servings

## LIMITED ONE-YEAR WARRANTY

**Warranty Coverage:** This product is warranted to be free from defects in materials or workmanship for a period of one (1) year from the original purchase date. This product warranty is extended only to the original consumer purchaser of the product and is not transferable. For a period of one (1) year from the date of original purchase of the product, our Repair Center will, at its option, either (1) repair the product or (2) replace the product with a reconditioned comparable model. These remedies are the purchaser's exclusive remedies under this warranty.

**Warranty Service:** To obtain warranty service, you must call our warranty service number at 1-800-233-9054 for return instructions on how to deliver the product, in either the original packaging or packaging affording an equal degree of protection to the Repair Center specified below. You must enclose a copy of your sales receipt or other proof of purchase to demonstrate eligibility for warranty coverage.

**To return** the appliance, ship to:

ATTN: Repair Center  
708 South Missouri Street  
Macon, MO 63552 USA

**To contact us,** please write to, call, or email:

Consumer Relations Department  
PO Box 7366  
Columbia MO 65205-7366 USA  
1-800-233-9054  
E-mail:  
consumer\_relations@toastmaster.com

**What Is Not Covered:** This warranty does not cover damage resulting from misuse, accident, commercial use, improper service or any other damage caused by anything other than defects in material or workmanship during ordinary consumer use. This warranty is invalid if the serial number has been altered or removed from the product. This warranty is valid only in the United States and Canada.

**LIMITATION ON DAMAGES:** THERE SHALL BE NO LIABILITY FOR ANY INCIDENTAL OR CONSEQUENTIAL DAMAGES FOR BREACH OF ANY EXPRESS OR IMPLIED WARRANTY OR CONDITION ON THIS PRODUCT.

**DURATION OF IMPLIED WARRANTIES:** EXCEPT TO THE EXTENT PROHIBITED BY APPLICABLE LAW, ALL IMPLIED WARRANTIES AND CONDITIONS, INCLUDING, WITHOUT LIMITATION, IMPLIED WARRANTIES AND CONDITIONS OF MERCHANTABILITY AND FITNESS FOR A PARTICULAR PURPOSE OR USE ON THIS PRODUCT ARE LIMITED IN DURATION TO THE DURATION OF THIS WARRANTY.

Some jurisdictions do not allow the exclusion or limitation of incidental or consequential damages, or allow limitations on how long an implied warranty lasts, so the above limitations or exclusions may not apply to you. This warranty gives you specific legal rights and you may have other rights under the laws of your jurisdiction.

For more information on our products, visit our website: [www.maxim-toastmaster.com](http://www.maxim-toastmaster.com)



*Hope you love using this and the other kitchen appliances in my line. I love to cook – as long as it's fast – and fun – and simple! These cool kitchen helpers will make it easy to cook a great meal – from start to finish – in 30 minutes. And they'll look awesome on your counter!*

*If you get satisfaction out of treating your family and friends to foods made with your own two hands, then get in the kitchen and have a blast! Try new flavors, tastes – experiment! And forget about those measuring cups and spoons – just eyeball it! If I can do it, you can too! Go for it!*

## **Rachael Ray**

All recipes Copyright © 2005, by Rachael Ray. All Rights Reserved. Used by Permission.

Printed in China 9/05

© 2005 Maxim®/Toastmaster® Inc.

P/N 61721



## Free Manuals Download Website

<http://myh66.com>

<http://usermanuals.us>

<http://www.somanuals.com>

<http://www.4manuals.cc>

<http://www.manual-lib.com>

<http://www.404manual.com>

<http://www.luxmanual.com>

<http://aubethermostatmanual.com>

Golf course search by state

<http://golfingnear.com>

Email search by domain

<http://emailbydomain.com>

Auto manuals search

<http://auto.somanuals.com>

TV manuals search

<http://tv.somanuals.com>