

OWNER'S MANUAL

Model No. TMEG21W

Toastmaster

LARGE NON-STICK GRIDDLE



IMPORTANT SAFEGUARDS

When using electrical appliances, basic safety precautions should always be followed, including the following:

1. Read all instructions.
2. Do not touch hot surfaces. Use handles or knobs. Use oven mitts or potholders.
3. To protect against electrical shock, do not immerse cord, probe or plug in water or other liquid.
4. Close supervision is necessary when any appliance is used by or near children.
5. Unplug from outlet when not in use and before cleaning. Allow to cool before putting on or taking off parts, and before cleaning the appliance.
6. Do not operate any appliance with a damaged cord or plug or after the appliance malfunctions, or has been damaged in any manner. Contact Consumer Service for examination, repair or adjustment.
7. The use of accessory attachments not recommended by the appliance manufacturer may cause injuries.
8. Do not use outdoors.
9. Do not let cord hang over edge of table or counter, or touch hot surfaces.
10. Do not place on or near a hot gas or electric burner, or in a heated oven.
11. Extreme caution must be used when moving an appliance containing hot oil or other hot liquids.
12. Always attach the Temperature Control Probe to the appliance first, then plug cord into the wall outlet. To disconnect, turn the Variable Temperature Control to OFF, then remove plug from the wall outlet.
13. Do not use appliance for other than intended use.

SAVE THESE INSTRUCTIONS
FOR HOUSEHOLD USE ONLY

ADDITIONAL IMPORTANT SAFEGUARDS

CAUTION HOT SURFACES: This appliance generates heat and escaping steam during use. Proper precautions must be taken to prevent the risk of burns, fires or other injury to persons or damage to property.

CAUTION: This appliance is hot during operation and retains heat for some time after turning off. Always use oven mitts when handling hot materials and allow metal parts to cool before cleaning. Do not place anything on top of the appliance while it is operating or while it is hot.

1. All users of this appliance must read and understand this Owner's Manual before operating or cleaning this appliance.
2. The cord to this appliance should be plugged into a 120V AC electrical outlet only.
3. If this appliance begins to malfunction during use, immediately unplug the cord.
Do not use or attempt to repair the malfunctioning appliance.
4. Do not leave this appliance unattended during use.

POLARIZED PLUG

This appliance has a polarized plug (one blade is wider than the other). To reduce the risk of electric shock, this plug is intended to fit into a polarized outlet only one way. If the plug does not fit fully in the outlet, reverse the plug. If it still does not fit, contact a qualified electrician. Do not attempt to modify the plug in any way.

SHORT CORD INSTRUCTIONS

A short power-supply cord is provided to reduce the risk resulting from becoming entangled in or tripping over a longer cord.

Do not use an extension cord with this product.

ELECTRIC POWER

If the electrical circuit is overloaded with other appliances, your appliance may not operate properly. It should be operated on a separate electrical circuit from other appliances.

PLASTICIZER WARNING

CAUTION: To prevent Plasticizers from migrating from the finish of the countertop or tabletop or other furniture, place NON-PLASTIC coasters or placemats between the appliance and the finish of the countertop or tabletop.

Failure to do so may cause the finish to darken, permanent blemishes may occur or stains can appear.

TEMPERATURE CONTROL PROBE

Use only the Temperature Control Probe (P/N 22851TM) supplied with this product. Using any other type of Temperature Control Probe may cause fire, electric shock, or injury.

GETTING TO KNOW YOUR GRIDDLE

PRODUCT MAY VARY SLIGHTLY FROM ILLUSTRATIONS.

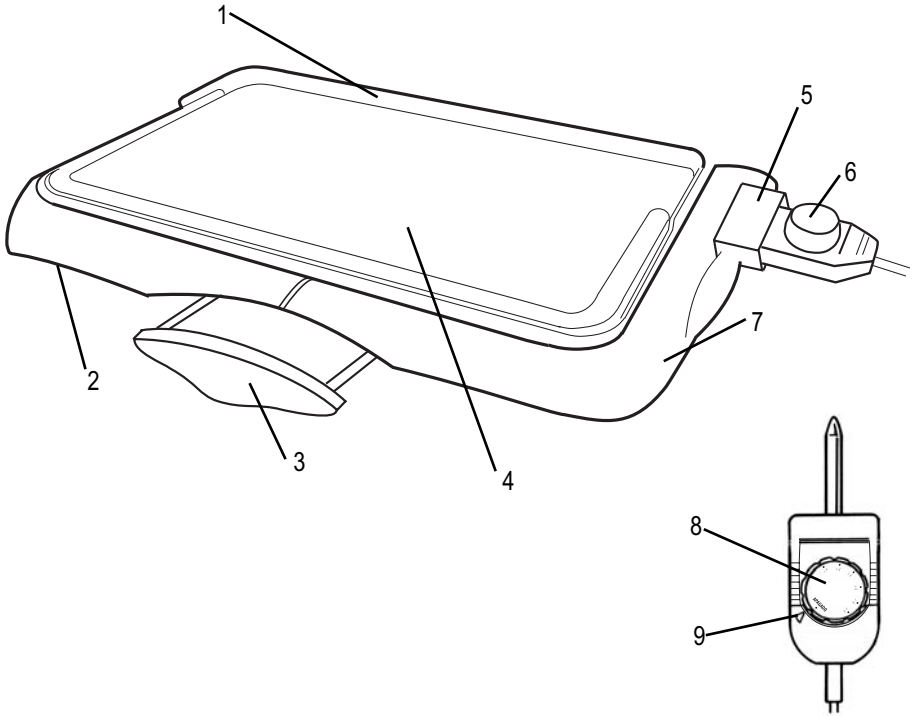

1. Backstop
2. Non-Skid Rubber Feet (not shown)
3. Drip Tray (P/N 22852)
4. Non-Stick Cooking Surface
5. Probe Receptacle
6. Temperature Control Probe (P/N 22851TM)
7. Cool-Edge Base
8. Variable Temperature Control
9. Power Light

OPERATING INSTRUCTIONS

1. Before using for the first time, clean the Griddle as outlined in the CLEANING INSTRUCTIONS (see USER MAINTENANCE INSTRUCTIONS).
2. Insert Drip Tray into rails under Griddle.
3. Turn Variable Temperature Control to OFF. Insert Probe firmly into Probe Receptacle, pushing until it is securely in place. Plug into 120V AC outlet.
4. **To Preheat:** Rotate the Variable Temperature Control so that the desired temperature is aligned with the Power Light. The Power Light will illuminate and remain on until the unit has reached the set temperature. The Power Light goes off when the unit has finished preheating. The Light will cycle on and off during use, indicating that the proper temperature is being maintained.

NOTE: Some foods such as eggs and pancakes cook better if the non-stick surface is conditioned with vegetable shortening before preheating. If necessary, remove excess oil with paper towel.

5. Carefully place the items to be cooked on the Griddle. Allow the food to cook, turning halfway through cooking time if needed. Refer to the SUGGESTED COOKING CHART for suggested cooking temperatures and times. **DO NOT LEAVE APPLIANCE UNATTENDED DURING USE!**
6. When finished cooking, turn the Variable Temperature Control to OFF and unplug from the outlet.
7. Allow the Griddle to cool completely before cleaning.

CAUTION: Because some countertop finishes are more affected by heat than others, use care not to place Griddle on surfaces where heat may cause a problem.

CAUTION: Griddle surfaces are hot during use.

SUGGESTED COOKING CHART

The following times are meant to be used as guidelines only. Time will vary due to the cut or thickness of the meat being cooked. To be sure that the food is truly done, use a cooking thermometer.

FOOD	TEMPERATURE (°F/°C)	TIME (min.)	DIRECTIONS
Bacon	325°/165°	8-16	DO NOT PREHEAT. Turn often.
Sausage	325°/165°	20-35	DO NOT PREHEAT. Turn often.
French Toast	350°/175°	6-12	Turn halfway into cooking time.
Ham Slices	350°/175°	15-20	Turn halfway into cooking time.
Sandwiches	350°/175°	6-10	Butter outside & brown both sides.
Pork Chops	350°/175°	20-35	Brown both sides then reduce temperature to 325°/165°. Turn halfway into cooking time.
Pancakes	400°/200°	4-8	Pour batter onto Griddle. When bubbles appear on top side, turn.
Steaks: (rare)	400°/200°	6-11	Turn halfway into cooking time.
(medium)	400°/200°	9-16	
(well done)	400°/200°	15-22	
Hamburger	400°/200°	6-18	Turn halfway into cooking time.

NOTE: The USDA recommends that meats such as beef, pork, lamb, etc. should be cooked to an internal temperature of 160°F/71°C and poultry products should be cooked to an internal temperature of 170°F/77°C - 180°F/82°C to be sure any harmful bacteria, Listeria and Ecoli, has been killed. When reheating meat/poultry products, they should also be cooked to an internal temperature of 165°F/74°C.

USER MAINTENANCE INSTRUCTIONS

This appliance requires little maintenance. It contains no user serviceable parts. Do not try to repair it yourself. Any servicing requiring disassembly must be performed by a qualified appliance repair technician.

CARE & CLEANING

NOTE: No parts should be placed in an automatic dishwasher.

1. Unplug and allow Griddle to cool completely before cleaning or moving.
2. Remove Temperature Control Probe from Probe Receptacle. **DO NOT IMMERSE PROBE, CORD OR PLUG IN WATER OR OTHER LIQUID.** Wipe Temperature Control Probe with a damp cloth and dry thoroughly.
3. When cool, remove Drip Tray and empty contents. Be sure the liquid has cooled before removing Drip Tray. Wash Griddle and Drip Tray in soapy water; rinse and dry thoroughly.

NOTE: A plastic pad with mild abrasive cleaner may be used to clean underside of Griddle (see HINTS FOR CARE & USE OF NON-STICK GRIDDLE SURFACE below).

CAUTION: Probe and Probe Receptacle must always be completely dry before use.

CARE & USE OF NON-STICK GRIDDLE SURFACE

- To avoid scratching the non-stick surface, **do not stack objects on the Griddle.**
- Use medium to low heat for best cooking results. Very high temperatures can cause discoloration and shorten the life span of any non-stick surface. If higher temperatures are necessary, preheat on medium for a few minutes.
- Use only nylon, plastic, or wooden utensils with care to avoid scratching the non-stick surface. Never cut food on the Griddle.
- Remove stubborn stains with a plastic scouring pad and mild dish washing liquid; **DO NOT USE STEEL WOOL.**

NOTES

LIMITED ONE-YEAR WARRANTY

Warranty Coverage: This product is warranted to be free from defects in materials or workmanship for a period of one (1) year from the original purchase date. This product warranty is extended only to the original consumer purchaser of the product and is not transferable. For a period of one (1) year from the date of original purchase of the product, our Repair Center will, at its option, either (1) repair the product or (2) replace the product with a reconditioned comparable model. These remedies are the purchaser's exclusive remedies under this warranty.

Warranty Service: To obtain warranty service, you must call our warranty service number at 1-800-233-9054 for return instructions on how to deliver the product, in either the original packaging or packaging affording an equal degree of protection to the Repair Center specified below. You must enclose a copy of your sales receipt or other proof of purchase to demonstrate eligibility for warranty coverage.

To return the appliance, ship to:

ATTN: Repair Center
708 South Missouri Street
Macon, MO 63552 USA

To contact us, please write to, call, or email:

Consumer Relations Department
PO Box 7366
Columbia, MO 65205-7366 USA
Phone: 1-800-233-9054
Email: consumer_relations@toastmaster.com

What Is Not Covered: This warranty does not cover damage resulting from misuse, accident, commercial use, improper service or any other damage caused by anything other than defects in material or workmanship during ordinary consumer use. This warranty is invalid if the serial number has been altered or removed from the product. This warranty is valid only in the United States and Canada.

LIMITATION ON DAMAGES: THERE SHALL BE NO LIABILITY FOR ANY INCIDENTAL OR CONSEQUENTIAL DAMAGES FOR BREACH OF ANY EXPRESS OR IMPLIED WARRANTY OR CONDITION ON THIS PRODUCT.

DURATION OF IMPLIED WARRANTIES: EXCEPT TO THE EXTENT PROHIBITED BY APPLICABLE LAW, ALL IMPLIED WARRANTIES AND CONDITIONS, INCLUDING, WITHOUT LIMITATION, IMPLIED WARRANTIES AND CONDITIONS OF MERCHANTABILITY AND FITNESS FOR A PARTICULAR PURPOSE OR USE ON THIS PRODUCT ARE LIMITED IN DURATION TO THE DURATION OF THIS WARRANTY.

Some jurisdictions do not allow the exclusion or limitation of incidental or consequential damages, or allow limitations on how long an implied warranty lasts, so the above limitations or exclusions may not apply to you. This warranty gives you specific legal rights and you may have other rights under the laws of your jurisdiction.

For more information on our products, visit our website: www.maxim-toastmaster.com.

Free Manuals Download Website

<http://myh66.com>

<http://usermanuals.us>

<http://www.somanuals.com>

<http://www.4manuals.cc>

<http://www.manual-lib.com>

<http://www.404manual.com>

<http://www.luxmanual.com>

<http://aubethermostatmanual.com>

Golf course search by state

<http://golfingnear.com>

Email search by domain

<http://emailbydomain.com>

Auto manuals search

<http://auto.somanuals.com>

TV manuals search

<http://tv.somanuals.com>