

3-Cup Rice Cooker

USE AND CARE GUIDE
MODEL TRC3



toastmaster®

IMPORTANT SAFEGUARDS

When using electrical appliances, basic safety precautions should always be followed including the following:

1. Read all instructions.
2. Do not touch hot surfaces. Use handles or knobs.
3. To protect against electrical shock do not immerse cord, plugs, or appliance in water or other liquid.
4. Close supervision is necessary when any appliance is used by or near children.
5. Unplug from outlet when not in use and before cleaning. Allow to cool before putting on or taking off parts.
6. Do not operate any appliance with a damaged cord or plug or after the appliance malfunctions or has been damaged in any manner. Contact Consumer Service for examination, repair or adjustment.
7. The use of accessory attachments not recommended by the appliance manufacturer may cause injuries.
8. Do not use outdoors.
9. Do not let cord hang over edge of table or counter, or touch hot surfaces.
10. Do not place on or near a hot gas or electric burner, or in a heated oven.
11. Extreme caution must be used when moving an appliance containing hot oil or other hot liquids.
12. To disconnect, raise Rice Cooking Selector Lever to the UP position, then remove plug from wall outlet.
13. Do not use appliance for other than intended use.

SAVE THESE INSTRUCTIONS

For Household Use Only



ADDITIONAL IMPORTANT SAFEGUARDS

CAUTION HOT SURFACES: This appliance generates heat and escaping steam during use. Proper precautions must be taken to prevent the risk of burns, fires, or other injury to persons or damage to property.

1. A person who has not read and understood all operating and safety instructions is not qualified to operate this appliance. All users of this appliance must read and understand this Owner's Manual before operating or cleaning this appliance.
2. If this appliance falls or accidentally becomes immersed in water, unplug it from the wall outlet immediately. **Do not reach into the water!**
3. When using this appliance, provide adequate air space above and on all sides for air circulation. Do not operate this appliance while it is touching or near curtains, wall coverings, clothing, dishtowels or other flammable materials.
4. To reduce the risk of fire, do not leave this appliance unattended during use.
5. If this appliance begins to malfunction during use, immediately unplug the cord. Do not use or attempt to repair a malfunctioning appliance!
6. The cord to this appliance should only be plugged into a 120V AC electrical wall outlet.
7. Do not use this appliance in an unstable position.
8. Do not use the Inner Pot or Glass Lid if cracked or damaged.
9. Avoid electric shock by unplugging the Rice Cooker before washing or adding water.
10. Never plug in the Rice Cooker without the Inner Pot inside the Main Housing.
11. To avoid burns, stay clear of the Steam Vent during cooking. Also, wait for the Rice Cooker to cool down completely before touching or cleaning the Main Housing and Glass Lid.
12. Never use the Inner Pot on a gas or electric cooktop or on an open flame.

13. Do not leave the plastic Rice Paddle or Rice Measuring Cup in the Inner Pot while on and in use.
14. Lift off lid carefully to avoid scalding, and allow water to drip into Rice Cooker.
15. To reduce the risk of electric shock, cook only in the removable container (Inner Pot). Do not pour liquid directly into the Main Housing. Never put liquid into the Main Housing, only into the Inner Pot.

Polarized Plug

This appliance has a polarized plug (one blade is wider than the other). To reduce the risk of electric shock, this plug is intended to fit into a polarized outlet only one way. If the plug does not fit fully in the outlet, reverse the plug. If it still does not fit, contact a qualified electrician. Do not attempt to modify the plug in any way.

Short Cord Instructions

A short power-supply cord is provided to reduce the risk resulting from becoming entangled in or tripping over a longer cord.

Do not use an extension cord with this product.

Electric Power

If the electrical circuit is overloaded with other appliances, your appliance may not operate properly. It should be operated on a separate electrical circuit from other appliances.



Getting to Know Your Toastmaster® 3-Cup Rice Cooker

Your product may vary slightly from illustration.

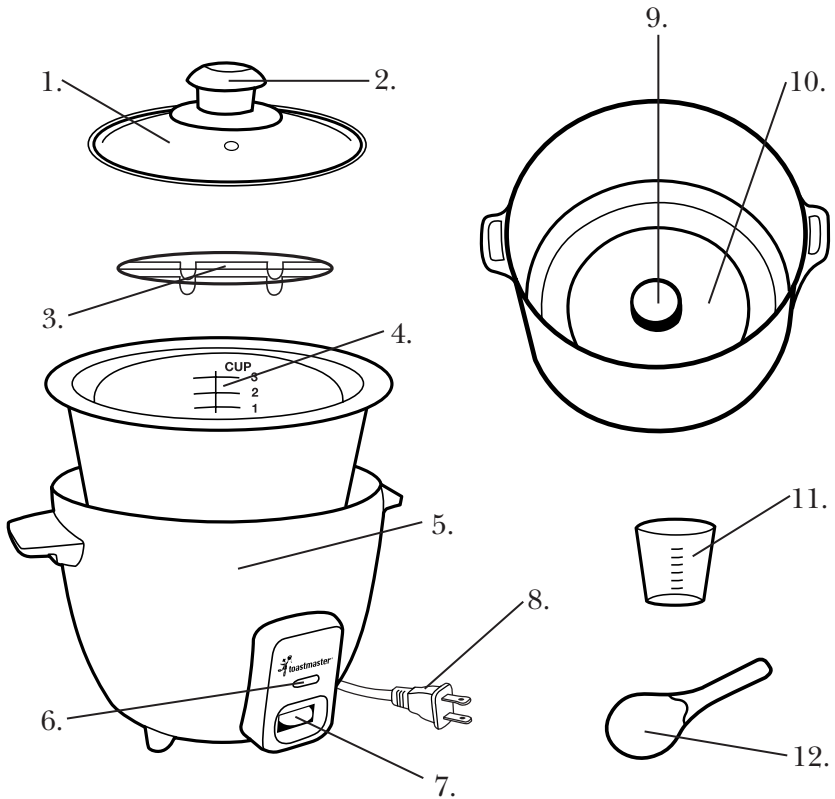

Figure 1

- | | |
|---------------------------------------|---------------------------------------|
| 1. Glass Lid Assembly
(P/N 20110W) | 7. Rice Cooking Selector Lever |
| 2. Lid Handle (P/N 20652W) | 8. Power Supply Cord |
| 3. Wire Cooking Rack
(P/N 20117) | 9. Thermostat |
| 4. Inner Pot (P/N 20118) | 10. Heating Plate |
| 5. Main Housing | 11. Rice Measuring Cup
(P/N 20111) |
| 6. COOK Light | 12. Rice Paddle (P/N 20112) |

Before Using for the First Time

1. Read all instructions.
2. Wash Inner Pot, Wire Cooking Rack, Glass Lid, Rice Measuring Cup and Rice Paddle in warm, soapy water. Rinse and dry well.
3. Never immerse Main Housing in water.
4. Never place liquid in the Main Housing. Place it only in the Inner Pot.
5. Never try to force the Rice Cooking Selector Lever to stay in the COOK Mode.
6. Never plug in the Cooker without first placing the Inner Pot inside the Main Housing.
7. Always be sure Inner Pot contains liquid, or be ready to add oil, butter or margarine immediately to the Inner Pot when you plug in the Cooker.
8. **Remember that the Rice Measuring Cup is not a standard measuring cup. When filled, it measures approximately $\frac{3}{4}$ cup.**
9. Never wash any removable parts of the Cooker in the dishwasher.
10. Save these instructions and refer to them often.
11. If the outside of the Inner Pot is wet when placed into the Cooker, this may cause a cracking noise while the unit heats up. Also, this may cause damage to the inner working of the appliance, so always wipe the outside of the Inner Pot completely dry before use.



Operating Instructions

Many varieties of rice can be used, including basmati, wild, black rice, arborio, risotto, saffron rice, brown, and long grain. We do not recommend using instant rice with this Rice Cooker.

1. Measure the amount of rice that you would like to cook. A 180 ml ($\frac{3}{4}$ cup) Rice Measuring Cup is included with your Rice Cooker. Filling the cup with rice makes approximately $2\frac{1}{2}$ cups of cooked rice.

NOTE: Make sure that the rice is leveled when the cup is filled. The Toastmaster® 3-Cup Rice Cooker has the capacity for 3 Rice Measuring Cups of dry rice.

2. *For Best Results...*

Pour desired amount of rice into a separate container. Wash and rinse the rice until the rinse water is clear.

3. Take the Inner Pot out of the Rice Cooker.

Place the washed rice into the Inner Pot and add appropriate amount of water. (If you are making 3 cups of dry rice, add water to the “3” mark in the inside of the Inner Pot.) See Figure 2.

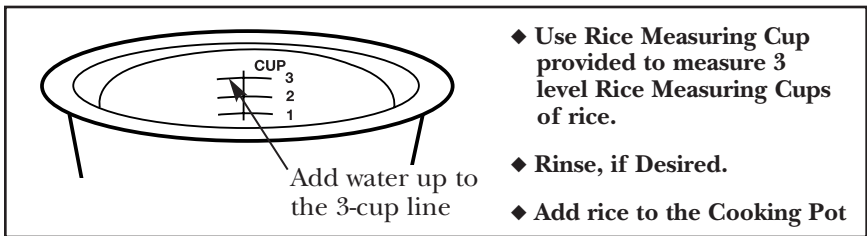

Figure 2

4. Replace the Inner Pot back into the Rice Cooker's Main Housing. Rotate it slightly to make sure that it is well seated on the Heating Plate/Thermostat Assembly.

NOTE: Always wipe the outside of the Inner Pot completely dry before use. If the outside of the Inner Pot is wet when placed into the Cooker, this may cause a cracking noise while the unit heats up. Also, this may cause damage to the inner workings of the appliance.

5. Replace the Glass Lid.

CAUTION: Do not operate the Automatic Rice Cooker without replacing the Lid. Burns or other serious injury may occur.

6. Plug the Automatic Rice Cooker into a 120V AC electrical outlet. Press the Rice Cooking Selector Lever down and the COOK Light will illuminate. The cooking process begins as soon as the Light illuminates.
7. When the Automatic Rice Cooker is done cooking, the Rice Cooking Selector Lever will move to the UP position and the COOK Light will turn off. For tender, fluffy rice, let the cooked rice sit for 15 minutes before stirring or removing. This allows the steam to continue cooking the rice.
8. When ready to serve, carefully open the Lid as steam will escape. Use the Rice Paddle provided or any other non-metal long-handle utensil to scoop and mix the rice well. Allow all steam to escape.
9. Unplug the Automatic Rice Cooker from the wall. Do not touch the Main Housing or Inner Pot until they have cooled completely.
10. Allow the Automatic Rice Cooker to cool completely before cleaning.
11. When the Automatic Rice Cooker is not being used, please keep it unplugged.

Long Grain Brown Rice Cooking Chart

The Toastmaster® 3-Cup Rice Cooker automatically shuts off when all the liquid evaporates from the Inner Pot. However, for fluffy rice, allow rice to stand for approximately 15 minutes, covered, before serving.

NOTE: Always place rice in Inner Pot before adding water.

Amount of Raw Rice	Water Level	Approx. Number of $\frac{1}{2}$ Cup Servings
1½ Rice Measuring Cups	to 3-cup line	6



Long Grain White Rice

Cooking Chart

The Toastmaster® 3-Cup Rice Cooker automatically shuts off when all the liquid evaporates from the Inner Pot. However, for fluffy rice, allow rice to stand for approximately 15 minutes, covered, before serving.

NOTE: Always place rice in Inner Pot before adding water.

Amount of Raw Rice	Water Level	Approx. Number of ½ Cup Servings
2 Rice Measuring Cups	to 2-cup line	8
3 Rice Measuring Cups	to 3-cup line	12

Steaming Food

GENERAL INFORMATION

Keep the Glass Lid on while cooking or steaming food, unless the recipe or chart specially calls for removing it. By removing the Glass Lid unnecessarily, you lose steam and valuable time. If you must remove it to stir or to add an ingredient, have the Rice Paddle or ingredient ready, add it, stir quickly and just as quickly replace the Glass Lid.

Using the Wire Cooking Rack

When steaming vegetables, the Wire Cooking Rack is a convenient accessory.

1. Clean and prepare your vegetables.

2. Place the Inner Pot into the Rice Cooker Heating Body. The length of steaming time is subject to your own personal tastes; do you prefer al dente (crunchy) steamed vegetables or a softer consistency?
3. Place the Wire Cooking Rack into the Inner Pot and add enough water to be level with the top of the Wire Cooking Rack.
4. Place a heat-resistant container onto the Wire Cooking Rack. Or, a steaming basket may be placed directly into the Inner Pot.
5. Add small vegetables to the heat-resistant container or the steaming basket. Larger vegetables can be placed directly onto the Steaming Rack. Replace the Glass Lid.
6. Plug the cord into a 120V AC electrical outlet. Press the Rice Cooking Selector Lever down to the COOK position. Make sure the COOK Light is ON. Steaming will start shortly.
7. Allow vegetables to steam to desired doneness. (See Vegetable Steaming Chart.)
8. The Rice Cooker may automatically shut OFF. If additional cooking is desired, unplug the unit and add more water. Replace the Glass Lid. Plug in the Rice Cooker, press the Rice Cooking Selector Lever down to COOK position and your Rice Cooker will resume steaming.
9. When your food has reached the desired doneness, raise the Rice Cooking Selector Lever and unplug after use.



Vegetable Steaming Chart*

Vegetable	Cook Time (min.)
Asparagus	8 – 10
Bean Sprouts	3 – 4
Beans: green, wax, French cut	8 – 10
Broccoli	11 – 13
Brussels Sprouts	11 – 13
Cabbage: shredded	6 – 8
wedges	14 – 16
Carrots	8 – 10
Cauliflower	11 – 13
Celery	8 – 12
Greens: collard, spinach, etc	6 – 11
Mushrooms: fresh sliced	3 – 4
Pea pods	4 – 6
Potatoes: (1)	10 – 12
(3)	19 – 22
Squash: acorn, butternut	13 – 16
Zucchini	10 – 12

* We have outlined a general guide to follow. Test for desired doneness when cooking times indicated have been reached. As you cook with this appliance, adapt times and measurements to your own personal tastes.

User Maintenance Instructions

This appliance contains no user serviceable parts. Do not try to repair it yourself. Any servicing requiring disassembly other than cleaning must be performed by a qualified appliance repair technician.

Always remember to unplug the unit from the wall outlet when not in use and before cleaning.

- ◆ Be careful not to dent the Inner Pot, especially the bottom of it. To work properly and produce the best cooking results, the Inner Pot must fit snugly on top of the thermostat.
- ◆ DO NOT let loose grains of rice or other food particles fall into the bottom of the Main Housing because they might prevent the thermostat from fitting tightly against the bottom of the Inner Pot and cause inadequate cooking.
- ◆ Use the plastic Rice Paddle or a wooden spoon to stir and remove food from the Inner Pot. NEVER use any metal utensils.
- ◆ Never use abrasive cleansers or scouring pads because they can damage the finish of both the Inner Pot and Main Housing.

Cleaning Instructions

NOTE: It is normal to have a brown “rice crust” coating the bottom layer of the Inner Pot when the rice has finished cooking and steaming.

- ◆ This appliance should be cleaned after every use. Unplug the unit from the wall outlet. NEVER immerse Main Housing or Power Cord in water. Allow the unit to cool before cleaning.
- ◆ Let the Rice Cooker cool. Fill Inner Pot with warm water and allow to sit for a while. Wash in warm, soapy water with a sponge and dry thoroughly with a cloth.
- ◆ The Wire Cooking Rack, Glass Lid, Rice Measuring Cup and Rice Paddle may also be washed in warm, soapy water.



CAUTION: Handle the Glass Lid with extreme care, as it may become slippery when wet.

- ◆ Never wash any removable parts of the Rice Cooker in the dishwasher.
- ◆ The Main Housing can be wiped clean with a soft, slightly damp cloth or sponge.
- ◆ **Never pour liquid into the Main Housing or immerse it in water.**

Storing Instructions

Unplug the unit from the wall outlet and clean all parts. Be sure all parts are dry before storing. Store appliance in its box or in a clean, dry place. Never store it while it is hot, wet or still plugged in. Never wrap Power Cord around the appliance.

To avoid damage to the Inner Pot or Glass Lid, wrap a soft cloth around the Lid and store it upside down over the Inner Pot.

Trouble Shooting

Symptom	Possible Solutions
No Indicator Lights are illuminated.	<p>Make sure the Automatic Rice Cooker is plugged in.</p> <p>Check between the Inner Pot and Heating Plate/Thermostat Assembly for any foreign substances. Be sure the area is clean.</p> <p>Make sure the Inner Pot is in the Main Housing.</p>
Water overflows during cooking.	<p>Before cooking, make sure you don't fill above top water level.</p> <p>Make sure Lid is closed before cooking.</p>

Symptom	Possible Solutions
<p>Cooked rice is too dry or not completely cooked.</p>	<p>Before cooking, make sure you add enough water to the Inner Pot for the total amount of raw rice added.</p> <p>After cooking, add ¼ cup water and set on COOK.</p> <p>Check between the Inner Pot and Heating Plate/Thermostat Assembly for any foreign substances. Be sure the area is clean.</p>
<p>Cooked rice is too watery.</p>	<p>Before cooking, make sure you don't add too much water to the Inner Pot for the total amount of raw rice added.</p> <p>Check between the Inner Pot and Heating Plate/Thermostat Assembly for any foreign substances. Be sure the area is clean.</p> <p>Make sure the cooking cycle is not interrupted. If the Power Cord is unplugged, the unit will not operate and the rice will not cook.</p>
<p>Rice is scorched.</p>	<p>Check between the Inner Pot and Heating Plate/Thermostat Assembly for any foreign substances. Be sure the area is clean.</p> <p>Be sure to wash the Inner Pot after each use.</p> <p>Be careful not to add easily-scorched ingredients such as sugar, to the recipe before cooking.</p>
<p>Steam escapes between Glass Lid and Inner Pot during cooking.</p>	<p>Check between the Glass Lid and Inner Pot for foreign substances, including rice kernels that may prevent the Glass Lid from closing all the way. Be sure the area is clean.</p>

If none of these Trouble Shooting solutions are successful, contact our Consumer Service Dept. at 800-947-3744 for further advice.



LIMITED ONE-YEAR WARRANTY

Warranty Coverage: This product is warranted to be free from defects in materials or workmanship for a period of one (1) year from the original purchase date. This product warranty is extended only to the original consumer purchaser of the product and is not transferable. For a period of one (1) year from the date of original purchase of the product, our Repair Center will, at its option, either (1) repair the product or (2) replace the product with a reconditioned comparable model. These remedies are the purchaser's exclusive remedies under this warranty.

Warranty Service: To obtain warranty service, you must call our warranty service number at 1-800-947-3744 for return instructions on how to deliver the product, in either the original packaging or packaging affording an equal degree of protection to the Repair Center specified below. You must enclose a copy of your sales receipt or other proof of purchase to demonstrate eligibility for warranty coverage.

To return the appliance, ship to:

ATTN: Repair Center
708 South Missouri Street
Macon, MO 63552 USA

To contact us, please write to, call, or email:

Consumer Relations Department
PO Box 7366
Columbia, MO 65205-7366 USA
1-800-947-3744
E-mail: consumer_relations@toastmaster.com

What Is Not Covered: This warranty does not cover damage resulting from misuse, accident, commercial use, improper service or any other damage caused by anything other than defects in material or workmanship during ordinary consumer use. This warranty is invalid if the serial number has been altered or removed from the product. This warranty is valid only in the United States and Canada.

LIMITATION ON DAMAGES: THERE SHALL BE NO LIABILITY FOR ANY INCIDENTAL OR CONSEQUENTIAL DAMAGES FOR BREACH OF ANY EXPRESS OR IMPLIED WARRANTY OR CONDITION ON THIS PRODUCT.

DURATION OF IMPLIED WARRANTIES: EXCEPT TO THE EXTENT PROHIBITED BY APPLICABLE LAW, ALL IMPLIED WARRANTIES AND CONDITIONS, INCLUDING, WITHOUT LIMITATION, IMPLIED WARRANTIES AND CONDITIONS OF MERCHANTABILITY AND FITNESS FOR A PARTICULAR PURPOSE OR USE ON THIS PRODUCT ARE LIMITED IN DURATION TO THE DURATION OF THIS WARRANTY.

Some jurisdictions do not allow the exclusion or limitation of incidental or consequential damages, or allow limitations on how long an implied warranty lasts, so the above limitations or exclusions may not apply to you. This warranty gives you specific legal rights and you may have other rights under the laws of your jurisdiction.

For more information on our products, visit our website: www.maxim-toastmaster.com.

© 2005 Toastmaster Inc.
All Rights Reserved

P/N 61784
Rev. 8/05
Printed in China

Keep Dated Sales Receipts for Warranty Service.

Keep this booklet. Record the following for reference:

Date purchased _____

Model number _____

Date code (stamped on bottom) _____

**EVERYBODY EATS. It's a fact of life.
But sometimes preparing
meals can become a chore.
That's why TOASTMASTER has been invited
into millions of kitchens just like yours
so we can HELP YOU MASTER your
mixing, baking, grilling, toasting,
brewing, heating and serving
tasks WITH EASE AND STYLE.
The TOASTMASTER name stands for a
CELEBRATION of INNOVATION designed
to serve your life and keep you
COOKIN' IN STYLE.**





toastmaster®

- *Makes up to 6 cups of cooked rice*
- *See-through glass lid*
- *Bonus rack included for steaming vegetables*
- *Measuring cup and rice paddle included*



Questions

Call toll free 1-800-947-3744

Monday–Friday, 8:00 a.m.-5:30 p.m. CST

www.maxim-toastmaster.com

TRC3

Free Manuals Download Website

<http://myh66.com>

<http://usermanuals.us>

<http://www.somanuals.com>

<http://www.4manuals.cc>

<http://www.manual-lib.com>

<http://www.404manual.com>

<http://www.luxmanual.com>

<http://aubethermostatmanual.com>

Golf course search by state

<http://golfingnear.com>

Email search by domain

<http://emailbydomain.com>

Auto manuals search

<http://auto.somanuals.com>

TV manuals search

<http://tv.somanuals.com>