

READ AND SAVE THESE INSTRUCTIONS

WARNING: A risk of fire and electrical shock exists in all electrical appliances and may cause personal injury or death. Please follow all safety instructions.

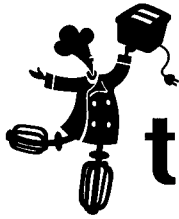

toastmaster[®]
cookin' in style



Five Cup Rice Cooker

Use and Care Guide - Model TRC5

- MAKES UP TO 10 CUPS COOKED RICE
- KEEP WARM SETTING
- STEAMS MEAT, FISH, FRUIT
- AUTO SHUT-OFF

IMPORTANT SAFEGUARDS

When using electrical appliances, basic safety precautions should always be followed to reduce the risk of fire, electric shock and injury to persons, including the following:

- Read all instructions before using appliance.
- Do not touch hot surfaces. Use handles or knobs. Use pot holders when removing cover or handling hot containers.
- To protect against electrical shock, do not immerse cord, plug or heating body in water or other liquid. See User Maintenance Instructions.
- Close supervision is necessary when any appliance is used near children.
- This appliance is not for use by children.
- Unplug from outlet when not in use. Unplug and allow to cool before putting on or taking off parts, and before cleaning.
- Do not operate any damaged appliance. Do not operate with a damaged cord or plug, or after the appliance malfunctions or has been dropped or damaged in any manner. Return appliance to the Toastmaster Service Center for examination, repair or adjustment.
- The use of accessory attachments not recommended by Toastmaster may cause injuries.
- Do not use outdoors or while standing in a damp area.
- Do not let cord hang over edge of table or counter, or touch hot surfaces.
- Do not place on or near a hot gas or electric burner, or in a heated oven.
- Extreme caution must be used when moving an appliance containing hot food, water, or other hot liquids.
- To disconnect, move the Rice Cooking Switch button up, then remove the plug from wall outlet.
- Do not use appliance for other than intended use.
- Lift and open cover carefully to avoid scalding, and allow water to drip into Rice Cooker.
- To reduce the risk of electrical shock, cook only in inner pot. Do not pour liquid into heating body.

SAVE THESE INSTRUCTIONS

CAUTION: A short power supply cord is provided to reduce the risk of personal injury resulting from becoming entangled in or tripping over a longer cord. Extension cords are available from local hardware stores and may be used if care is exercised in their use. If an extension cord is required, special care and caution is necessary. Also the cord must be: (1) marked with an electrical rating of 125 V and at least 10 A, 1250W, and (2) the cord must be arranged so that it will not drape over the countertop or tabletop where it can be pulled on by children or tripped over accidentally.

POLARIZED PLUG: This appliance has a polarized plug, (one blade is wider than the other). As a safety feature to reduce the risk of electrical shock, this plug is intended to fit in a polarized outlet only one way. If the plug does not fit fully in the outlet, reverse the plug. If it still does not fit, contact a qualified electrician. Do not attempt to modify the plug in any way.

THIS PRODUCT IS FOR HOUSEHOLD USE ONLY

ADDITIONAL IMPORTANT SAFEGUARDS

- **CAUTION:** This appliance generates heat and escaping steam during use. Proper precautions must be taken to prevent the risk of burns, fires or other damage to persons or property.
- All users of this appliance must read and understand this Owner's Manual before operating or cleaning this appliance.
- The cord to this appliance should be plugged into a 120V AC electrical outlet only.
- When using this appliance, provide adequate air space above and on all sides for air circulation. Do not allow this appliance to touch curtains, wall coverings, clothing, dish towels or other flammable materials during use.
- Do not leave this appliance unattended during use.
- This appliance generates steam. Do not operate uncovered.
- If this appliance begins to malfunction during use, immediately unplug the cord. Do not use or attempt to repair the malfunctioning appliance. Do not use the Inner Pot or Glass Lid if cracked or chipped.
- **CAUTION:** Before starting to cook, clean the bottom of the Inner Pot and the surface of the heating plate, then turn the inner pot clockwise and anti-clockwise so that it sits properly onto the heating plate inside the rice cooker. Otherwise the unit will not work or will be damaged.

BEFORE USING FOR THE FIRST TIME

Clean the Glass Lid, Inner Pot, Ladle and Measuring Cup following the User Maintenance Instructions.

DO NOT IMMERSE THE HEATING BODY OF THE RICE COOKER IN WATER OR ANY OTHER LIQUID.

GETTING TO KNOW YOUR TOASTMASTER TRC5 AUTOMATIC RICE COOKER

Before using your Automatic Rice Cooker for the first time, you must become familiar with all of the parts. Read all instructions and safeguards carefully.

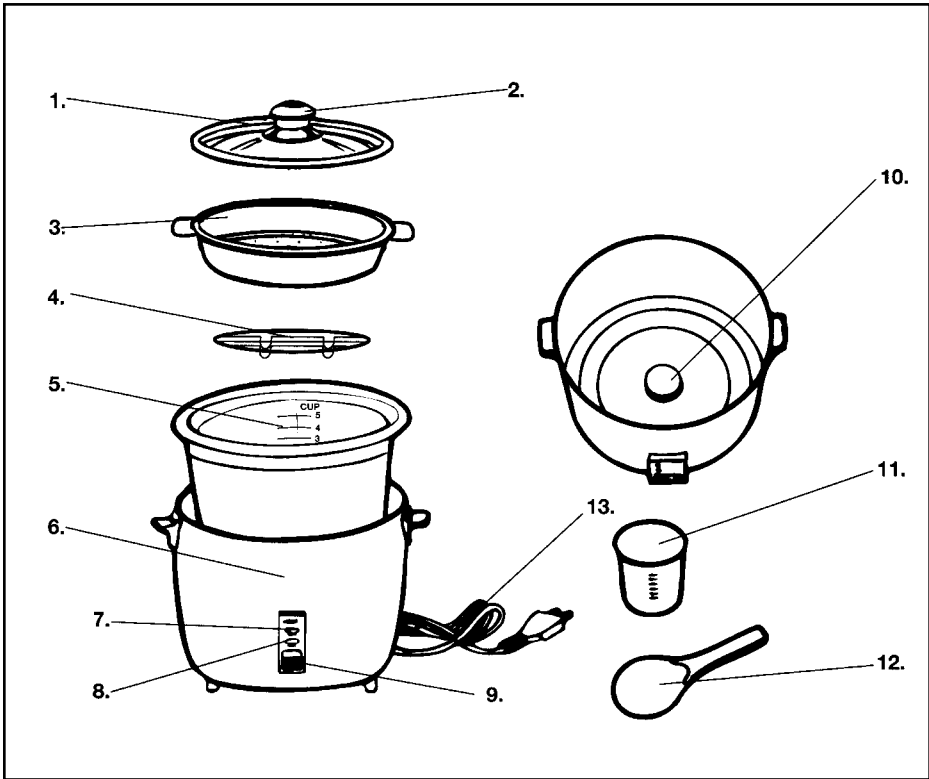

- | | |
|------------------|-------------------------------|
| 1. Glass Lid | 8. "COOK" Light |
| 2. Lid Knob | 9. Rice Cooking Switch Button |
| 3. Steaming Tray | 10. Heating Plate |
| 4. Cooking Rack | 11. Rice Measuring Cup |
| 5. Inner Pot | 12. Ladle |
| 6. Heating Body | 13. Power Supply Cord |
| 7. "WARM" Light | |

INSTRUCTIONS FOR USE

1. Measure the raw rice.

Measure raw rice for desired amount with the measuring cup provided, 180 ml. One (1) cup of the uncooked rice will make about 2 cups of cooked rice.

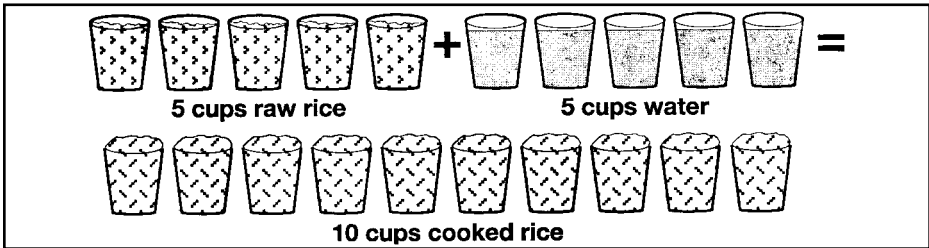

Note: The Rice Cooker is capable of cooking up to 5 cups of raw, uncooked rice. (See figure.)

Many varieties of rice can be used, including basmati, wild, black rice, arborio, risotto, saffron rice, and long grain. We do not recommend using instant rice with this Rice Cooker.

Whole grains such as barley can also be prepared with this Rice Cooker. Follow package instructions.

2. Wash the measured rice in a separate bowl, if desired.
3. Make sure the appliance is unplugged. Put rice into the Inner Pot and add water.

For 5 cups of raw rice to be cooked, add 5 measuring cups of water. The WATER LEVEL of the Inner Pot is for reference, and adjust the amount of water to your personal taste. Do not use wine, broth or other liquids. The ratio of rice to water is always 1:1.

4. Set the Inner Pot into the Cooker.

Clean inner surface of the Cooker, and set the Inner Pot into the Cooker. Make sure that the Inner Pot is directly in contact with the heating plate by turning it slightly from right to left until it seats properly.

NOTE: If the outside of the Inner Pot is wet when placed into the Cooker, this may cause a cracking noise while the unit heats up. Also this may incur damage to the inner working of the appliance, so always wipe the outside of the Pot completely before use.

5. Cover with the lid.

DO NOT OPERATE THIS APPLIANCE UNCOVERED – STEAM IS GENERATED DURING USE.

6. Plug the cord into a 120V AC electrical outlet. Switch the Rice Cooker on. Make sure the "Cook" light is on. Steaming will start.
7. Steam the rice. After the rice is cooked, the Rice Cooking Switch automatically switches to "WARM."
8. When the Automatic Rice Cooker is done cooking, the "WARM" Light will illuminate.

For best results, let the cooked rice set for 15 minutes before stirring or removing. This allows the steam to finish the cooking process.

9. Mix the rice. After rice has steamed for 15 minutes, carefully open the Lid as steam will escape. Use the Ladle provided or any other non-metal long-handled utensil to scoop and mix the rice well. Allow all steam to escape. Rice is now ready to serve.

CAUTION: Steam will escape. Use oven mitts or hot pads as Lid, Inner Pot and Heating Body will be HOT

10. **NOTE: Do not warm rice for more than 12 hours. It is recommended to consume the rice within a 12 hour period.**
If the "WARM" mode is not desired, simply unplug the Automatic Rice Cooker from the wall. Do not touch the Heating Body or Inner Pot until they have cooled completely.
11. Allow the Automatic Rice Cooker to cool completely before cleaning.
12. When the Automatic Rice Cooker is not being used, please keep it unplugged.

TO KEEP COOKED RICE WARM & TASTY

- Wash rice — Bran gives an unpleasant smell to the cooked rice. Be sure to wash rice thoroughly. Washing with water will be effective to quickly and thoroughly remove bran.

NOTE: Some rice suppliers suggest not to wash rice because vitamins may be lost.

- Keep the lid securely closed to prevent dry, discolored effect and unpleasant smell of rice. Keep the glass lid perfectly closed.
- Keep the Inner Pot and glass lid clean after use. Wash in warm, soapy water. Rinse thoroughly and dry.
- Avoid keeping the Rice Cooker in operation
 - When there is only a small amount of rice to keep warm
 - When the rice scoop is inside the Cooker.

USER MAINTENANCE INSTRUCTIONS

This appliance should be cleaned after every use.

1. Unplug the Automatic Rice Cooker from the outlet when not in use or before cleaning. Never immerse Heating Body in water or any other liquid! Allow the Automatic Rice Cooker to cool completely before cleaning.
2. Do not use abrasive cleaners or scouring pads or steel wool to clean the Automatic Rice Cooker.
3. Heating Body: Lightly wipe the exterior with a damp cloth or sponge. **DO NOT IMMERSE HEATING BODY INTO WATER OR ANY OTHER LIQUID.** Dry thoroughly with a soft cloth.
4. Inner Pot: Fill with hot water and let soak for a while and then wash with hot soapy water with a sponge and dry thoroughly with a cloth.
5. Glass Lid, Measuring Cup, Ladle: Wash in warm soapy water. Rinse thoroughly and dry.
CAUTION: Handle the glass lid with extreme care, as it may become slippery when wet.
6. Heating Plate, Thermostat: Grains of rice or other foreign matters may stick to the heating plate. These must be removed to prevent inadequate cooking. To remove cooked rice, smooth sand paper can be used. Smooth out and polish the spot for good contact between the heating plate and the bottom of the Inner Pot.
7. There are no user serviceable parts inside this appliance.

Any servicing requiring disassembly other than the above cleaning must be performed by an authorized service center.

USING THE STEAMING TRAY AND COOKING RACK

The Steaming Tray is specifically designed to steam vegetables. When steaming large vegetables, the Cooking Rack is a convenient addition.

To use the Steaming Tray or Rack:

1. Clean and prepare your vegetables. Cut vegetables into bite-sized pieces.
2. Place the Inner Pot into the Rice Cooker Body. Be sure the Inner Pot is seated properly. Using a standard measuring cup, add 2 cups (16 oz.) of water to Inner Pot.
3. When steaming smaller vegetables or chunks, place vegetables directly into the Steaming Tray. (If you are cooking combinations of vegetables, be sure they require the same cooking time and also cut pieces uniformly to assure all vegetables will be finished steaming at the same time.)
4. Place the Steaming Tray onto the rim of the Inner Pot and cover with Glass Lid.
5. If you are cooking large vegetables, place the Cooking Rack directly into the Inner Pot. Place vegetables onto the Rack and cover with the Glass Lid. Add 1 cup (8 oz.) water. Periodically check water level so Pot does not boil dry.
6. Plug the cord into a 110V/120V AC electrical outlet. Move the Rice Cooking Switch to the "COOK" position. Make sure the "Cook" light is on. Steaming will start shortly.
7. Allow vegetables to steam to desired doneness. See "Vegetable Steaming Chart." Switch to "WARM" and unplug after use.

VEGETABLE STEAMING CHART

Vegetable	Cooking Time (Minutes)
Asparagus	14 - 17
Bean Sprouts	10 - 12
Beans: green, wax, French cut	15 - 18
Broccoli (Flowerettes)	25 - 30
Brussels Sprouts	20 - 25
Cabbage: shredded	12 - 15
Cabbage: wedges	20 - 25
Carrots	14 - 17
Cauliflower (Flowerettes)	25 - 30
Celery	8 - 12
Greens: collard, spinach, etc.	18 - 22
Mushrooms: fresh, sliced	6 - 9
Pea pods	8 - 10
Potatoes	32 - 35
Squash: acorn, butternut	20 - 25
Zucchini	12 - 15

- This Vegetable Steaming Chart is only a guide. The length of steaming time is subject to your own personal tastes. Test for desired doneness when cooking times indicated have been reached. As you cook with this appliance, adapt times and measurements to your own personal tastes.
- If vegetables are not done to your liking, add more water to the Inner Pot, cover with Glass Lid and restart the Rice Cooker.
- Do not exceed 3-1/2 cups of water in the Inner Pot when using the Steaming Tray.

SERVICE INFORMATION

Please refer to warranty statement to determine if in-warranty service applies. This appliance must be serviced by a Toastmaster authorized service center. Unauthorized service will void warranty.

If an authorized service center is not available locally, your appliance may be returned postage prepaid to our National Service Center at the address shown on the back of this book.

Products must be adequately protected to avoid shipping damage. Surround your appliance with three inches of protective padding and include a copy of your dated sales receipt and a note explaining the problem you have experienced. We recommend insuring your package. No CODs accepted.

LIMITED ONE YEAR WARRANTY

Warranty: This Toastmaster® product is warranted to be free from defects in materials or workmanship for a period of (1) year from the original purchase date. This product warranty covers only the original consumer purchaser of the product.

Warranty Coverage: This warranty is void if the product has been damaged by accident in shipment, unreasonable use, misuse, neglect, improper service, commercial use, repairs by unauthorized personnel, normal wear and tear, improper assembly, installation or maintenance abuse or other causes not arising out of defects in materials or workmanship. This warranty is effective only if the product is purchased and operated in the USA, and does not extend to any units which have been used in violation of written instructions furnished with the product or to units which have been altered or modified or to damage to products or parts thereof which have had the serial number removed, altered, defaced or rendered illegible.

Implied Warranties: ANY IMPLIED WARRANTIES WHICH THE PURCHASER MAY HAVE ARE LIMITED IN DURATION TO ONE (1) YEAR FROM THE DATE OF PURCHASE. Some states do not allow limitations on how long an implied warranty lasts, so the above limitation may not apply to you.

Warranty Performance: During the above one-year warranty period, a product with a defect will be either repaired or replaced with a reconditioned comparable model (at our option) when the product is returned to the Repair Center, or the purchase price refunded. The repaired or replacement product will be in warranty for the balance of the one-year warranty period and an additional one-month period. No charge will be made for such repair or replacement.

Service and Repair: Should the appliance malfunction, you should first call toll-free 1 (800) 947-3744 between the hours of 9:00 am and 5:00 pm Central Standard Time and ask for CONSUMER SERVICE stating that you are a consumer with a problem. Please refer to model number TRC5 when you call.

In-Warranty Service (USA): For an appliance covered under the warranty period, no charge is made for service or postage. Call for return authorization (1 800 947-3744).

Out-of Warranty Service: A flat rate charge by model is made for out-of-warranty service. Include \$ 10 (U.S.) for return shipping and handling. We will notify you by mail of the amount of the charge for service and require you to pay in advance for the repair or replacement.

For Products Purchased in the USA, but Used in Canada: You may return the product insured, packaged with sufficient protection, and postage and insurance prepaid to the USA address listed below. Please note that all customs duty / brokerage fees, if any, must be paid by you and we will require you to pay the cost of customs duty / brokerage fees to us in advance of our performing any service.

Risk During Shipment: We cannot assume responsibility for loss or damage during incoming shipment. For your protection, carefully package the product for shipment and insure it with the carrier. Be sure to enclose the following items with your appliance: any accessories related to your problem, your full return address and daytime phone number, a note describing the problem you experienced, a copy of your sales receipt or other proof of purchase to determine warranty status. C.O.D. shipments cannot be accepted.

To return the appliance, ship to:

Attn: Repair Center
708 South Missouri Street
Macon, MO 63552

Email: consumer_relations@toastmaster.com
www.Toastmaster.com

To contact us, please write to or call:

P.O. Box 6916
Columbia, MO 65205-6916
1(800) 947-3744

Limitation of Remedies: No representative or person is authorized to assume for us any other liability in connection with the sale of our products. There shall be no claims for defects or failure of performance or product failure under any theory of tort, contract or commercial law including, but not limited to negligence, gross negligence, strict liability, breach of warranty and breach of contract. Repair, replacement or refund shall be the sole remedy of the purchaser under this warranty, and **in no event shall we be liable for any incidental or consequential damages, losses or expenses.** Some states do not allow the exclusion or limitation of incidental or consequential damages, so the above limitation or exclusion may not apply to you.

Legal Rights: This warranty gives you specific legal rights, and you may also have other rights which vary from state to state.

KEEP DATED SALES RECEIPT FOR WARRANTY SERVICE.

Keep this booklet. Record the following for reference:

Date purchased _____

Model number _____

Date code (stamped on bottom) _____

EVERYBODY EATS. It's a fact of life.

**But sometimes preparing
meals can become a chore.**

**That's why TOASTMASTER has been invited
into millions of kitchens just like yours
so we can HELP YOU MASTER your
mixing, baking, grilling, toasting,
brewing, heating and serving
tasks WITH EASE AND STYLE.**

**The TOASTMASTER name stands for a
CELEBRATION of INNOVATION designed
to serve your life and keep you
COOKIN' IN STYLE.**

Free Manuals Download Website

<http://myh66.com>

<http://usermanuals.us>

<http://www.somanuals.com>

<http://www.4manuals.cc>

<http://www.manual-lib.com>

<http://www.404manual.com>

<http://www.luxmanual.com>

<http://aubethermostatmanual.com>

Golf course search by state

<http://golfingnear.com>

Email search by domain

<http://emailbydomain.com>

Auto manuals search

<http://auto.somanuals.com>

TV manuals search

<http://tv.somanuals.com>