

FARBERWARE® MILLENNIUM®



USE & CARE INSTRUCTIONS FAMILY SIZE WAFFLE BAKER WITH REVERSIBLE COOKING PLATES

FWB275

Download from [Www.Somanuals.com](http://www.Somanuals.com). All Manuals Search And Download.

IMPORTANT SAFEGUARDS

When using electrical appliances, basic safety precautions should always be followed, including the following:

1. Read all instructions.
2. Do not touch hot surfaces. Use handles or knobs. Use oven mitts or potholders.
3. To protect against electric shock, do not immerse cord, plugs or appliance in water or other liquid.
4. Close supervision is necessary when any appliance is used by or near children.
5. Unplug from outlet when not in use and before cleaning. Allow to cool before putting on or taking off parts, and before cleaning the appliance.
6. Do not operate any appliance with a damaged cord or plug or after the appliance malfunctions, or has been damaged in any manner. Contact Consumer Service for examination, repair or adjustment.
7. The use of accessory attachments not recommended by the appliance manufacturer may cause injuries.
8. Do not use outdoors.
9. Do not let cord hang over edge of table or counter, or touch hot surfaces.
10. Do not place on or near a hot gas or electric burner, or in a heated oven.
11. Extreme caution must be used when moving an appliance containing hot oil or other hot liquids.
12. To disconnect, turn the Adjustable Temperature Control Dial to 150, then remove plug from wall outlet.
13. Do not use appliance for other than intended use.

SAVE THESE INSTRUCTIONS
THIS PRODUCT IS FOR HOUSEHOLD USE ONLY

ADDITIONAL IMPORTANT SAFEGUARDS

CAUTION HOT SURFACES: This appliance generates heat and escaping steam during use. Proper precautions must be taken to prevent the risk of burns, fires or other injury to persons or damage to property.

CAUTION: This appliance is hot during operation and retains heat for some time after turning OFF. Always use oven mitts when handling hot materials and allow metal parts to cool before cleaning. Do not place anything on top of the appliance while it is operating or while it is hot.

1. All users of this appliance must read and understand these Use & Care Instructions before operating or cleaning this appliance.
2. The cord to this appliance should be plugged into a 120V AC electrical outlet only.
3. If this appliance begins to malfunction during use, immediately unplug the cord. Do not use or attempt to repair the malfunctioning appliance.
4. Do not leave this appliance unattended during use.
5. When using this appliance, provide adequate air space above and on all sides for air circulation. Do not allow this appliance to touch curtains, wall coverings, clothing, dish towels or other flammable materials during use.

IMPORTANT: Wearing oven mitts, use the Lid Handle to hold the top cover (Lid) open while placing or removing food on the cooking surface to prevent accidental closing and injury.

POLARIZED PLUG

This appliance has a polarized plug (one blade is wider than the other). To reduce the risk of electric shock, this plug is intended to fit into a polarized outlet only one way. If the plug does not fit fully in the outlet, reverse the plug. If it still does not fit, contact a qualified electrician. Do not attempt to modify the plug in any way.

SHORT CORD INSTRUCTIONS

A short power-supply cord is provided to reduce the risk resulting from becoming entangled in or tripping over a longer cord.

Do not use an extension cord with this product.

ELECTRIC POWER

If the electrical circuit is overloaded with other appliances, your appliance may not operate properly. It should be operated on a separate electrical circuit from other appliances.

GETTING TO KNOW YOUR **FARBERWARE**[®] FAMILY SIZE WAFFLE BAKER

PRODUCT MAY VARY SLIGHTLY FROM ILLUSTRATIONS

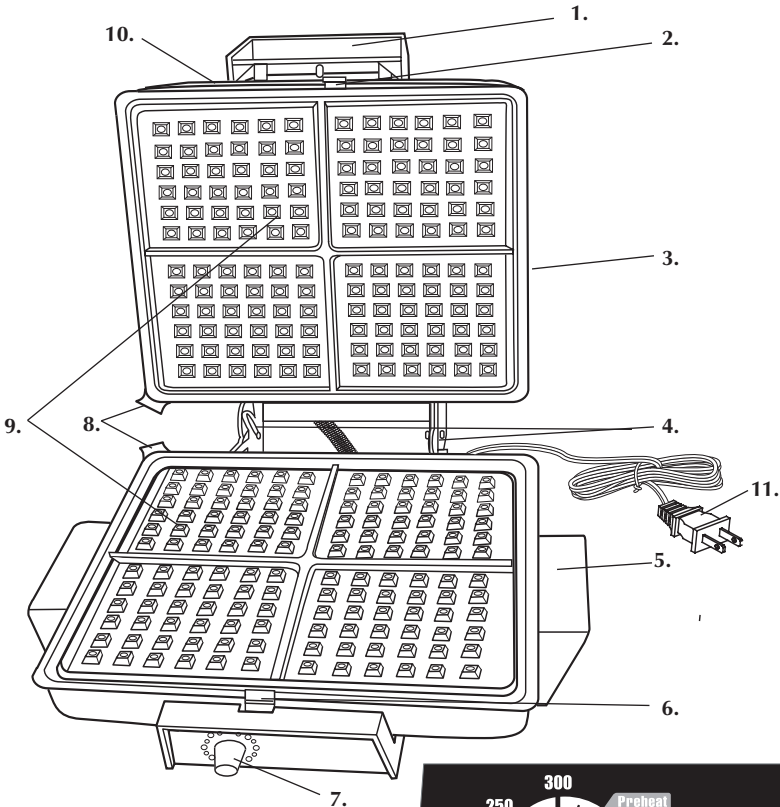

1. Lid Handle
2. Upper Plate Release Clip
3. Waffle Baker Body
4. Adjustable Hinge
5. Lower Handle
6. Lower Plate Release Clip
7. Adjustable Temperature Control Dial
8. Drain Spout

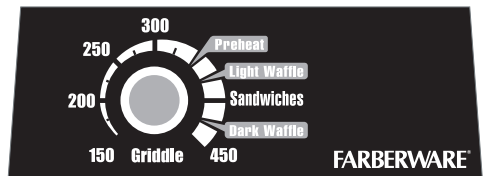

Adjustable Temperature Control Dial

9. Reversible Waffle/Griddle Plates (2) (P/N 18090)
10. Ready Light Indicator (on Lid, not shown)
11. Electrical Cord with Polarized Plug

OPERATING INSTRUCTIONS

IMPORTANT: Before using for the first time, operate the appliance without batter in order to burn off residues on the Cooking Plates.

1. Carefully unpack Waffle Baker and remove all packaging materials. Before using the Waffle Baker for the first time, wipe both Reversible Waffle/Griddle Plates with a damp cloth to remove all dust. Wipe all outside surfaces with a slightly damp, soft cloth. Never immerse Waffle Baker body in water.
2. Place the appliance on a dry, clean and flat countertop surface.
3. **Install both Reversible Plates before use.** Making sure the appliance is unplugged, place both clean Plates, either Waffle or Griddle-side-up on a working surface near the unit.
4. Open Lid, raise the Hinge up and lay the top back so that both Lids lie flat on the countertop.

IMPORTANT: ALWAYS INSTALL BOTH PLATES WITH EITHER WAFFLE OR GRIDDLE-SIDE-UP.

5. **Install the bottom Plate.** Grasp a Plate, with the Drain Spout away from the electrical cord, on the left rear of the unit (see Figure 3).
6. Position the Plate so that its lower edge lines up with the hinge side of the lower body of the unit. Insert and slide the Plate so that it rests against the Lower Plate Release Clip. Press the Plate down into the body until the front Release Clip snaps into position over the Plate.

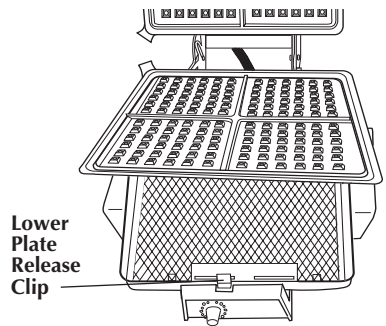

Figure 3

7. **Install the top Plate**, either Waffle or Griddle-side-up, with the Drain Spout away from the electrical cord, and in the matching corner as the bottom Plate.
8. Position the Plate so that its lower edge lines up with the hinge side of the upper body of the unit. Insert the Plate so that it rests against the Upper Plate Release Clip. Press the Plate down into the body until the top Release Clip snaps into position over the Plate.
9. To burn off residues on the Cooking Plates, it will be necessary to operate the unit for a few minutes before initial use. Do not add batter or oil during this time.
10. Allow the Waffle Baker to operate until smoke and odor dissipate, then unplug unit and allow it to cool.

OPERATING INSTRUCTIONS (Continued)

NOTE: Some odor may still be detected during initial use; this is normal and should disappear after one or two uses.

CAUTION: Do not remove or change the Plates while the unit is hot. The appliance must cool completely before removing or changing the Plates.

11. **To Remove Cooled Plates**, use one hand to pull out on the metal Upper Plate Release Clip at the top of the Plate, use the other hand to pull the Plate out from the body of the unit as it is released. Remove the bottom Plate following the same procedure.

USING THE WAFFLE BAKER

1. With both Plates installed Waffle side up, condition each Plate. To condition, brush the exposed Waffle surface with cooking oil and close the Lid. This needs to be done before each use.

NOTE: The Waffle Baker is coated with a non-stick surface. Do not use spray-on oils, grease or shortening, as they can cause build-up on the Reversible Plates. Use cooking oil instead.

2. Plug appliance into 120V AC electrical outlet. The Ready Light Indicator will illuminate. Turn the Temperature Control Dial to PREHEAT.
3. When the Ready Light Indicator goes off, the unit is ready for use. Using a protective oven mitt, lift the Lid by the Handle and pour approximately 1 cup of batter onto the lower Waffle Plate using an "X" pattern and carefully close the Lid. Do not force shut. Steam will be released between the Plates. Caution should be taken to prevent hands from coming into contact with the steam.
4. Turn the Temperature Control Dial to the desired setting. The Ready Light Indicator will illuminate.

NOTE: The amount of batter used may vary with each recipe.

CAUTION: Do not leave the unit unattended during use!

CAUTION: To avoid burns, caution should be taken when handling the Waffle Baker. The sides of the Reversible Plates are exposed and may be hot.

5. When the Ready Light Indicator goes off the second time, using a protective oven mitt, gently lift the Lid by the Handle to check for brownness. If the Lid is difficult to lift, the waffle may not be done. Close the Lid and watch for steaming to stop before checking again.

OPERATING INSTRUCTIONS (Continued)

6. Remove waffle when browned. Always use either plastic or wooden utensils to avoid scratching the nonstick surface of the Plates. Never use metal tongs, forks or knives as these can damage the coating on the Plates.

NOTE: After removing your waffle, keep the Waffle Baker closed to preserve the heat until ready for the next batch of waffles.

7. If more waffles are desired, immediately pour batter onto the Plate and using the Handle, close the Lid. Adjust Temperature Control Dial as needed.
8. When finished baking waffles, turn the Temperature Control Dial to the lowest setting. Unplug from the wall outlet.

CAUTION: Do not remove or change the Plates while the unit is hot. The appliance must cool completely before removing or changing the Plates.

CAUTION: To avoid burns, caution should be taken when handling the Waffle Baker. The sides of the Reversible Plates are exposed and may be hot.

9. If waffles are not to be consumed immediately, place the waffles on a paper napkin or cooling rack to absorb condensation. To keep hot, place in an ovenproof dish on an oven rack, and warm at about 200° to 250°F. Waffles will keep for about 20 minutes before they begin to dry out.

NOTE: The Light Waffle Control Setting can be used to reheat previously baked waffles.

USING THE OPEN GRIDDLE

1. This unit opens into a 2-sided, flat Griddle. Open Lid, raise the Hinge up and lay the top back so that both Lids lie flat on the countertop.
2. Following the instructions outlined earlier in this manual, install both Griddle Plates into the unit making sure that both Drain Spouts face each other as shown.

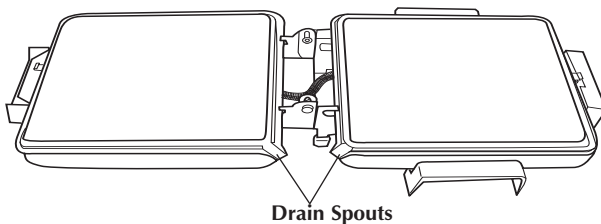

OPERATING INSTRUCTIONS (Continued)

3. Place a short, heat-resistant container (approximately 1 cup capacity) under the Drain Spouts to catch hot grease.
4. Condition both of the Griddle Plates before each use. Brush the exposed Griddle surface with cooking oil. Close the Lid. Turn the Temperature Control Dial to PREHEAT if recommended.

NOTE: For faster preheat, keep Lid closed. Using protective oven mitts, open Griddle using the Lid Handle after preheat is completed.

5. Plug appliance into 120V AC electrical outlet. The Ready Light Indicator will illuminate.
6. When the Ready Light Indicator goes off, the Griddle is ready for use. Turn the Temperature Control Dial to the desired temperature setting, place food on Griddle Plates and cook to desired doneness. Consult GRIDDLE COOKING CHART for suggested cooking guidelines.
7. Always use either plastic or wooden utensils to avoid scratching the nonstick surface of the Plates. Never use metal tongs, forks or knives as these can damage the coating on the Plates.
8. When finished grilling, turn the Adjustable Temperature Control Dial to the lowest setting. Unplug from the wall outlet.

CAUTION: Do not remove or change the Plates while the unit is hot. The appliance must cool completely before removing or changing the Plates.

CAUTION: To avoid burns, caution should be taken when handling the Waffle Baker. The sides of the Reversible Plates are exposed and may be hot.

GRIDDLE COOKING CHART

Food	Temperature Setting	Preheat
Bacon	375°F	No
Cube Steak	350°F	Yes
French Toast	350°F	Yes
Hamburgers	350°F	No
Pancakes	450°F	Yes
Sausage	350°F	No
Warming/Serving	150°F	Yes

USING THE SANDWICH GRIDDLE

1. Following the instructions outlined in the section USING THE OPEN GRIDDLE, install both Griddle Plates into the unit making sure that both Drain Spouts face each other.
2. Condition both of the Griddle Plates before each use, brush the exposed Griddle surface with cooking oil. Close the Lid. Turn the Temperature Control Dial to PREHEAT if recommended.

NOTE: For faster preheat, keep Lid closed. Using protective oven mitts, open Griddle using the Lid Handle after preheat is completed.

3. Plug appliance into 120V AC electrical outlet. The Ready Light Indicator will illuminate.
4. When the Ready Light Indicator goes off, the Sandwich Griddle is ready for use. Turn the Temperature Control Dial to the desired temperature setting, place food on Griddle Plates, lower the Lid and grill sandwiches to desired doneness.
5. Always use either plastic or wooden utensils to avoid scratching the nonstick surface of the Plates. Never use metal tongs, forks or knives as these can damage the coating on the Plates.
6. When finished grilling, turn the Adjustable Temperature Control Dial to the lowest setting. Unplug from the wall outlet.

CAUTION: Do not remove or change the Plates while the unit is hot. The appliance must cool completely before removing or changing the Plates.

CAUTION: To avoid burns, caution should be taken when handling the Waffle Baker. The sides of the Reversible Plates are exposed and may be hot.

USER MAINTENANCE INSTRUCTIONS

This appliance requires little maintenance. It contains no user serviceable parts. Do not try to repair it yourself. Any servicing requiring disassembly must be performed by a qualified appliance repair technician.

CARE AND CLEANING

CAUTION: Do not immerse the Waffle Baker, cord, or plug in water or any other liquid.

Unplug and allow to cool before cleaning. Do not use steel wool, scouring pads or abrasive cleaners, as this will damage the finish.

CLEANING REVERSIBLE COOKING PLATES

The unit should be completely cool before cleaning.

Always remove the Reversible Plates from the appliance before cleaning.

Wipe Non-Stick Reversible Plates with absorbent paper towel or a soft cloth.

NOTE: Your Waffle Baker has non-stick coated Reversible Plates. Do not use abrasive cleaners, metal cleaning brushes or metal scouring pads. This could damage the non-stick surface.

Although the Reversible Plates are coated with a non-stick coating, some batter or ingredients may still adhere to the Reversible Plates. To remove, allow the Reversible Plates to soak in warm water before attempting to clean. Remove stubborn stains with a plastic mesh pad or nylon bristle brush and a little non-abrasive detergent.

NOTE: Wash Reversible Plates by hand. They are NOT dishwasher safe.

OUTSIDE CLEANING

Wipe with a non-abrasive cleaner and a soft, damp cloth.

STORAGE

Unplug unit and allow to cool. Store in its box or in a clean, dry place. Never store Waffle Baker while it is hot or still plugged in.

Never wrap cord tightly around the appliance. Do not put any stress on cord where it enters unit, as this could cause cord to fray and break.

The Waffle Baker is designed to stand on its Hinge end for neat and compact storage.

HELPFUL HINTS AND TIPS

- Sift all dry ingredients.
- Egg yolks should be separated from egg whites before mixing.
- Beating egg whites separately, and then folding into the batter, will create lighter and crispier waffles.
- Egg whites should be beaten until they form stiff peaks. Stir 1/4 of beaten egg whites into batter to lighten it, then gently fold the rest of the egg whites into the batter (there should be white streaks in the batter). Do not over-mix batter when adding egg whites.
- It is not necessary to beat egg yolks and milk separately; add to the combined flour mixture, and use a whisk or hand mixer to blend.
- Do not open the Waffle Baker during the first minute of baking, or waffles will separate. Completely bake waffles before removing them from the unit.
- When waffles are done, the Lid should lift open easily. Wearing protective oven mitts, use the Lid Handle to gently lift the Lid. If the Lid pulls, wait another minute and try lifting it open again.
- Waffles can be made ahead of time, then refrigerated or frozen. When ready to eat, place defrosted waffles in your Waffle Baker and reheat waffles using the Light Waffle setting. When serving waffles to several people at once, a toaster or oven is ideal.

FOR LOW-FAT, LOW-CHOLESTEROL WAFFLES

- All recipes work equally well with skim milk.
- Leave out egg yolks altogether. All leavening properties come from the beaten egg whites.
- Use liquid vegetable oils, like canola, corn or sunflower, instead of butter.

FOR HIGHER-FIBER WAFFLES

- Substitute 1/2-cup, or more, of white flour with whole wheat flour.
- Substitute 1/4-cup of wheat or white flour with oat bran.

FOR SUGAR-FREE WAFFLES

- Substitute sugar with Splenda® No Calorie Sweetener or any other sugar substitute. Follow package directions for substitution quantities.
- Enjoy your sugarless waffles with sugar-free maple syrup. There are many wonderful brands available on the market today.

WAFFLE RECIPES

BASIC WAFFLES

1-3/4 cups all-purpose flour
2 teaspoons baking powder
1/2 teaspoon salt
3 eggs, separated
2 tablespoons sugar
1-1/2 cups milk
1/2 cup vegetable oil

1. Condition and preheat Waffle Baker.
2. Sift flour, baking powder, and salt together in a bowl.
3. Use an electric mixer to beat the whites until soft peaks form. Sprinkle in the sugar and continue to beat until stiff.
4. Use the Mixer to blend egg yolks, milk and vegetable oil together.
5. Pour the milk mixture into the dry ingredients and whisk together until just mixed.
6. Gently fold egg white mixture into the batter.
7. Pour approximately 1 cup of batter onto the lower Waffle Plate using an "X" pattern. Close the Lid, turn the Temperature Control Dial to the desired setting, and bake. Repeat with remaining batter.

Makes 10 (4-inch) waffles

CORN WAFFLES

2 (8-1/2-oz) packages corn muffin mix
2 eggs
1/4 cup vegetable oil
1-1/2 cups milk
1 (15-oz) can whole kernel corn, drained
2 (4-oz) cans chopped green chilies, drained
2 cups grated American Cheese

1. Condition and preheat Waffle Baker.
2. Use a spoon to stir corn muffin mix, eggs, vegetable oil, and milk together. The batter will be slightly lumpy.
3. Stir in corn, chilies and cheese.
4. Pour approximately 1 cup of batter onto the lower Waffle Plate using an "X" pattern. Close the Lid, turn the Temperature Control Dial to the desired setting, and bake. Repeat with remaining batter.

Makes 12 (4-inch) waffles

BELGIAN WAFFLES

2-2/3 cups all-purpose flour
2-1/4 tsp. RED STAR® active dry yeast
2 tablespoons sugar
1 teaspoon salt
1-3/4 cups milk
1/4 cup water
1/4 cup butter
3 eggs, separated

1. Sift flour, yeast, salt and sugar together in a bowl.
2. In a microwave or double boiler, heat milk, water and butter until very warm, 120°-130°F (butter does not need to melt).
3. Use an electric mixer to blend the eggs into the milk mixture.
4. Pour the milk mixture into the dry ingredients and use the mixer to mix thoroughly.
5. Cover the bowl tightly with plastic wrap or foil and refrigerate for at least 6 hours or overnight.
6. Condition and preheat Waffle Baker.
7. Pour approximately 1 cup of batter onto the lower Waffle Plate using an "X" pattern. Close the Lid, turn the Temperature Control Dial to the desired setting, and bake. Repeat with remaining batter.

Makes 12 (4-inch) waffles

CRAISINS® AND PECAN WAFFLES

- 1-3/4 cups all-purpose flour
- 2 teaspoons baking powder
- 1/2 teaspoon salt
- 3 eggs, separated
- 2 tablespoons sugar
- 1 teaspoon vanilla
- 1-1/2 cups milk
- 1/2 cup vegetable oil
- 1 cup craisins® (sweetened dried cranberries)
- 1 cup chopped pecans

1. Condition and preheat Waffle Baker.
2. Sift flour, baking powder, and salt together in a bowl.
3. Use an electric mixer to beat the whites until soft peaks form. Sprinkle in the sugar and continue to beat until stiff. Blend in vanilla.
4. Use the Mixer to blend egg yolks, milk and vegetable oil together.
5. Pour the milk mixture into the dry ingredients and whisk together until just mixed.
6. Gently fold egg white mixture, craisins® and pecans into the batter.
7. Pour approximately 1 cup of batter onto the lower Waffle Plate using an "X" pattern. Close the Lid, turn the Temperature Control Dial to the desired setting, and bake. Repeat with remaining batter.

Makes 10 (4-inch) waffles

CHOCOLATE CHIP WAFFLES

1-3/4 cups all-purpose flour
2 teaspoons baking powder
1/2 teaspoon salt
3 eggs, separated
2 tablespoons sugar
1-1/2 cups milk
1/2 cup vegetable oil
1 cup semi-sweet chocolate chips

1. Condition and preheat Waffle Baker.
2. Sift flour, baking powder, and salt together in a bowl.
3. Use an electric mixer to beat the whites until soft peaks form. Sprinkle in the sugar and continue to beat until stiff.
4. Use the Mixer to blend egg yolks, milk and vegetable oil together.
5. Pour the milk mixture into the dry ingredients and whisk together until just mixed.
6. Gently fold egg white mixture and chocolate chips into the batter.
7. Pour approximately 1 cup of batter onto the lower Waffle Plate using an "X" pattern. Close the Lid, turn the Temperature Control Dial to the desired setting, and bake. Repeat with remaining batter.

Makes 10 (4-inch) waffles

WHOLE WHEAT WAFFLES

1 cup all-purpose flour
1 cup whole wheat flour
4 teaspoons baking powder
1/2 teaspoon salt
4 teaspoons sugar
2 eggs, separated
2 cups milk
1/2 cup vegetable oil

1. Condition and preheat Waffle Baker.
2. Sift whole wheat flour, all-purpose flour, baking powder, and salt together in a bowl.
3. Use an electric mixer to beat the whites until soft peaks form. Sprinkle in the sugar and continue to beat until stiff.
4. Use the Mixer to blend egg yolks, milk and vegetable oil together.
5. Pour the milk mixture into the dry ingredients and whisk together until just mixed.
6. Gently fold egg white mixture into the batter.
7. Pour approximately 1 cup of batter onto the lower Waffle Plate using an "X" pattern. Close the Lid, turn the Temperature Control Dial to the desired setting, and bake. Repeat with remaining batter.

Makes 10 (4-inch) waffles

WHOLE WHEAT BANANA NUT WAFFLES

- 1 cup whole wheat flour
- 1 cup all-purpose flour
- 2 teaspoons baking powder
- 1/2 teaspoon salt
- 2 eggs, separated
- 2 tablespoons sugar
- 1 teaspoon vanilla
- 1-1/2 cups milk
- 1/4 cup melted butter
- 2 medium bananas, mashed
- 1 cup chopped walnuts

1. Condition and preheat Waffle Baker.
- 2, Sift whole wheat flour, all-purpose flour, baking powder, and salt together in a bowl.
3. Use an electric mixer to beat the egg whites until soft peaks form. Sprinkle in the sugar and continue to beat until stiff. Blend in vanilla.
4. Use the mixer to blend the egg yolks, milk, and butter together.
5. Pour the milk mixture into the dry ingredients and whisk together until just mixed.
6. Stir in bananas and nuts.
7. Gently fold egg white mixture into batter.
8. Pour approximately 1 cup of batter onto the lower Waffle Plate using an "X" pattern. Close the Lid, turn the Temperature Control Dial to the desired setting, and bake. Repeat with remaining batter.

Makes 10 (4-inch) waffles

PEANUT BUTTER WAFFLES

2 cups all-purpose flour
4 teaspoons baking powder
1 teaspoon salt
2 eggs, separated
4 tablespoons sugar
1 teaspoon vanilla
2 cups milk
1 tablespoon vegetable oil
1/2 cup peanut butter

1. Condition and preheat Waffle Baker.
2. Sift flour, baking powder, and salt together in a bowl.
3. Use an electric mixer to beat the whites until soft peaks form. Sprinkle in the sugar and continue to beat until stiff. Blend in vanilla.
4. Use the Mixer to blend egg yolks, milk, vegetable oil and peanut butter together.
5. Pour the milk mixture into the dry ingredients and whisk together until just mixed.
6. Gently fold egg white mixture into the batter.
7. Pour approximately 1 cup of batter onto the lower Waffle Plate using an "X" pattern. Close the Lid, turn the Temperature Control Dial to the desired setting, and bake. Repeat with remaining batter.

Makes 10 (4-inch) waffles

CHOCOLATE WAFFLES

- 2 cups all-purpose flour
- 2 teaspoons baking powder
- 1/2 teaspoon salt
- 4 teaspoons sugar
- 2 eggs, separated
- 1-1/3 cups milk
- 1-1/2 teaspoons vanilla
- 1/4 cup butter
- 3 (1-oz) squares semi-sweet chocolate

1. Condition and preheat Waffle Baker.
2. Melt butter and chocolate together in microwave or double boiler.
3. Sift flour, baking powder, and salt together in a bowl.
4. Use an electric mixer to beat the whites until soft peaks form. Sprinkle in the sugar and continue to beat until stiff. Blend in vanilla.
5. Use the Mixer to blend egg yolks, milk together.
6. Pour the milk mixture into the dry ingredients and whisk together until just mixed.
7. Gently fold egg white mixture into the batter.
8. Pour approximately 1 cup of batter onto the lower Waffle Plate using an "X" pattern. Close the Lid, turn the Temperature Control Dial to the desired setting, and bake. Repeat with remaining batter.

Makes 8 (4-inch) waffles

FARBERWARE®

LIMITED ONE-YEAR WARRANTY

Warranty Coverage: This product is warranted to be free from defects in materials or workmanship for a period of one (1) year from the original purchase date. This product warranty is extended only to the original consumer purchaser of the product and is not transferable. For a period of one (1) year from the date of original purchase of the product, our Repair Center will, at its option, either (1) repair the product or (2) replace the product with a reconditioned comparable model. These remedies are the purchaser's exclusive remedies under this warranty.

Warranty Service: To obtain warranty service, you must call our warranty service number at 1-800-233-9054 for return instructions on how to deliver the product, in either the original packaging or packaging affording an equal degree of protection to the Repair Center specified below. You must enclose a copy of your sales receipt or other proof of purchase to demonstrate eligibility for warranty coverage.

To return the appliance, ship to:

ATTN: Repair Center
708 South Missouri Street
Macon, MO 63552 USA

To contact us, please write to, call, or email:

Consumer Relations Department
PO Box 7366
Columbia MO 65205-7366 USA
1-800-233-9054
E-mail:consumer_relations@toastmaster.com

What Is Not Covered: This warranty does not cover damage resulting from misuse, accident, commercial use, improper service or any other damage caused by anything other than defects in material or workmanship during ordinary consumer use. This warranty is invalid if the serial number has been altered or removed from the product. This warranty is valid only in the United States and Canada.

LIMITATION ON DAMAGES: THERE SHALL BE NO LIABILITY FOR ANY INCIDENTAL OR CONSEQUENTIAL DAMAGES FOR BREACH OF ANY EXPRESS OR IMPLIED WARRANTY OR CONDITION ON THIS PRODUCT.

DURATION OF IMPLIED WARRANTIES: EXCEPT TO THE EXTENT PROHIBITED BY APPLICABLE LAW, ALL IMPLIED WARRANTIES AND CONDITIONS, INCLUDING, WITHOUT LIMITATION, IMPLIED WARRANTIES AND CONDITIONS OF MERCHANTABILITY AND FITNESS FOR A PARTICULAR PURPOSE OR USE ON THIS PRODUCT ARE LIMITED IN DURATION TO THE DURATION OF THIS WARRANTY.

Some jurisdictions do not allow the exclusion or limitation of incidental or consequential damages, or allow limitations on how long an implied warranty lasts, so the above limitations or exclusions may not apply to you. This warranty gives you specific legal rights and you may have other rights under the laws of your jurisdiction.

FARBERWARE® and Millennium® are registered trademarks of Farberware Inc.®
Manufactured and sold pursuant to a license from Farberware Inc.®

For more information on our products, visit our website:
www.maxim-toastmaster.com.

©2006 All rights reserved.
Made in China

P/N 61861
4/06

Free Manuals Download Website

<http://myh66.com>

<http://usermanuals.us>

<http://www.somanuals.com>

<http://www.4manuals.cc>

<http://www.manual-lib.com>

<http://www.404manual.com>

<http://www.luxmanual.com>

<http://aubethermostatmanual.com>

Golf course search by state

<http://golfingnear.com>

Email search by domain

<http://emailbydomain.com>

Auto manuals search

<http://auto.somanuals.com>

TV manuals search

<http://tv.somanuals.com>