



860S and 880S Series Rotary Sprinklers Installation & Service Instructions

Introduction

The 860S and 880S series full circle and adjustable part-circle rotary sprinklers are designed specifically for golf course applications.

Manufactured from durable, high-strength engineering plastic and stainless-steel components, the 880S series sprinklers incorporate many innovative and time-proven features for lasting, maintenance-free operation.

Prior to installing the sprinkler, read through the recommended installation and start-up procedures. Please observe all **WARNINGS** and **CAUTIONS** when installing and operating this equipment.

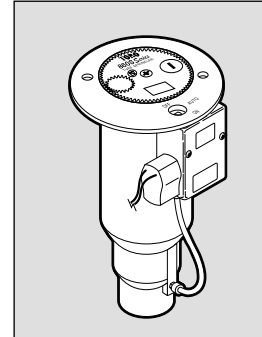

860S Electric VIH

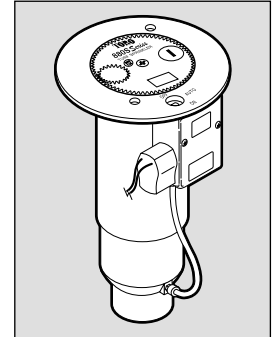

880S Electric VIH

Features

- Adjustable part-circle (30°–330°) and full circle models available
- Arc adjustment from top of sprinkler
- Standard stainless-steel riser resists scoring from embedded debris
- Full 3" (7.6 cm) pop-up clears tall grasses
- Nozzles color-coded by radius and gallonage
- Cap serves as an effluent water indicator
- Variable stator
- Standard pressure regulation settings of 50 psi (3.4 bar), 65 psi (4.5 bar), 80 psi (5.5 bar) or 100 PSI (6.9 bar) to ensure consistently accurate nozzle performance regardless of elevation
- Three body activation types available: Electric VIH, Normally Open Hydraulic VIH, and Check-O-Matic
- Three body thread types available: NPT, BSP and ACME
- Manual control at the sprinkler, On-Off-Auto (Electric only)
- Bowl-vented discharge (atmospheric) minimizes the differential pressure required for regulation and ensures positive valve closure (electric models only)
- All internal components serviceable from the top of the sprinkler
- Large selection of color-coded nozzles available
- Durable plastic and stainless-steel construction
- Spike-Guard™ solenoid for superior surge protection

Specifications and Performance/Application Data

860S Series

- Radius: 54'–80' (16.4 m–24.4 m)
- Flow Rate: 14.1–44.5 GPM (44.3–155.9 l/mn)
- Trajectory: 25°
- Arc: Full Circle or Adjustable Part Circle (30°–330°)
- Recommended Operating Pressure: 50–100 PSI (3.4–6.9 bar)
- Minimum Pressure: 40 PSI (2.8 bar)
- Maximum Pressure: 150 PSI (10.3 bar)
- Precipitation Rate:
 - Minimum: 0.37"/hr (9.4 mm/hr)
 - Maximum: 0.75"/hr (19.1 mm/hr)
- Body Height: 10" (25.4 cm)
- Pop-Up Height: 3" (7.6 cm)
- 1" NPT, BSP or ACME Female Thread Inlet
- Spike Guard™ Solenoid:
 - 24 V a.c., 50/60 Hz
 - Inrush Current: 50 Hz, 0.17 Amps (4.1 VA)
60 Hz, 0.12 Amps (2.9 VA)
 - Holding Current: 50 Hz, 0.15 Amps (3.6 VA)
60 Hz, 0.10 Amps (2.4 VA)
- Manual Control: On-Off-Auto
- Check-O-Matic model checks up to 37' (11.2 m) of elevation.
- Color-coded Nozzles (see nozzle color code chart, p. 3)

880S Series

- Radius: 53'–83' (16.2 m – 25.3 m)
- Flow Rate: 14.3–52.9 GPM (54.1–200.2 l/mn)
- Trajectory: 25°
- Arc: Full Circle or Adjustable Part Circle 30°–330°
- Recommended Operating Pressure: 50–100 PSI (3.4–6.9 bar)
- Minimum Pressure: 40 PSI (2.8 bar)
- Maximum Pressure: 150 PSI (10.3 bar)
- Precipitation Rate:
 - Minimum: 0.39"/hr (9.9 mm/hr)
 - Maximum: 0.74"/hr (18.8 mm/hr)
- Body Height: 11" (27.9 cm)
- Pop-Up Height: 3" (7.6 cm)
- 1.5" NPT, BSP or ACME Female Thread Inlet
- Spike Guard™ Solenoid:
 - 24 V a.c., 50/60 Hz
 - Inrush Current: 50 Hz, 0.17 Amps (4.1 VA)
60 Hz, 0.12 Amps (2.9 VA)
 - Holding Current: 50 Hz, 0.15 Amps (3.6 VA)
60 Hz, 0.10 Amps (2.4 VA)
- Manual Control: On-Off-Auto
- Check-O-Matic model checks up to 37' (11.2 m) of elevation.
- Color-Coded Nozzles (see nozzle color code chart, p. 3)

860S Series Sprinkler Performance Data

Base Pressure	Nozzle Set 61		Nozzle Set 62		Nozzle Set 63		Nozzle Set 64		Nozzle Set 65		Nozzle Set 66		Nozzle Set 67	
	psi	GPM	Radius	GPM	Radius	GPM	Radius	GPM	Radius	GPM	Radius	GPM	Radius	GPM
50	14.1	54	18.3	58	20.1	59	24.0	61	28.8	63	30.1	63	31.5	63
65	16.2	57	21.1	61	23.2	63	27.8	65	32.4	67	33.8	71	35.4	71
80	18.0	58	23.6	63	25.9	65	31.1	69	36.7	71	37.9	73	39.5	74
100	20.1	61	26.5	66	29.2	69	35.0	73	41.2	76	42.6	78	44.5	80

Radius shown in feet
 Toro recommends the use of a 1¼" (30mm) swing joint at flows over 25 GPM (95 LPM)
 Sprinkler radius of throw per ASAE standard S398.1
 ■ Not available at these pressures

880 Series Sprinkler Performance Data

Base Pressure	Nozzle Set 81		Nozzle Set 82		Nozzle Set 83		Nozzle Set 84		Nozzle Set 85		Nozzle Set 86		Nozzle Set 87		Nozzle Set 88	
	psi	GPM	Radius	GPM	Radius	GPM	Radius	GPM	Radius	GPM	Radius	GPM	Radius	GPM	Radius	GPM
50	14.3	53	18.7	57	20.8	60	25.1	63	31.3	65	32.9	65	35.2	65	38.3	65
65	16.5	56	21.6	61	23.9	63	28.9	69	34.8	71	36.1	71	38.3	71	41.6	71
80	18.4	57	24.1	65	26.7	67	32.3	71	38.9	77	40.4	77	42.5	77	47.1	77
100	20.6	60	27.0	69	29.9	71	36.3	77	43.7	81	45.4	81	47.8	83	52.9	83

Radius shown in feet
 Sprinkler radius of throw per ASAE standard S398.1
 ■ Not available at these pressures

Sprinkler Application Data

Nozzle Color Code			
Nozzle	Main	Inner	Intermediate
1	Yellow	Red	Gray
2	Blue	Red	Gray
3	Brown	Red	Red
4	Orange	Red	Red
5	Green	Red	Beige
6	Gray	Red	Beige
7	Black	Red	Beige
*8	Red	Red	Beige

* 880S series sprinkler only

Sprinkler Spacing Guidelines

- Square Spacing**
 - No wind - 55% of diameter
 - 4 mph wind - 50% of diameter
 - 8 mph wind - 45% of diameter
- Triangular Spacing**
 - No wind - 60% of diameter
 - 4 mph wind - 55% of diameter
 - 8 mph wind - 50% of diameter
- Single-Row Spacing**
 - No wind - 50% of diameter
 - 4 mph wind - 50% of diameter
 - 8 mph wind - 45% of diameter

Note: Designing for zero (0) mph wind conditions is not recommended. Design for worst wind conditions.

For additional information, refer to Toro Technical Data Manual, form number 490-1737.

Precipitation Rate Formulas

- Square-spaced sprinklers in pattern:

$$\frac{\text{GPM of full circle} \times 96.3}{(\text{Spacing})^2}$$

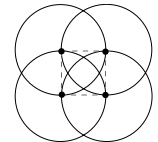

- Triangular-spaced sprinklers in pattern:

$$\frac{\text{GPM of full circle} \times 96.3}{(\text{Spacing})^2 (0.866)}$$

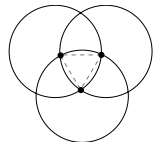

- Area and flow:

$$\frac{\text{Total GPM of zone} \times 96.3}{\text{Total irrigated square feet of zone}}$$

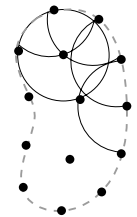

- Single row:

$$\frac{\text{GPM of full circle} \times 96.3}{(\text{Spacing}) (\text{Scallop})}$$

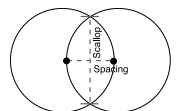

Installation Procedure

To assure maximum performance from your 800S series sprinklers, read these instructions completely prior to installation or service.

Constructing Swing Joints

1. Construct or provide triple swing joints for each sprinkler as shown in **Figure 1**. Use PVC or ABS pipe nipple for the sprinkler connection.

Note: On sites where the possibility of heavy equipment rolling over a sprinkler exists, the swing joint will flex preventing damage to the lateral or main lines. On a new installation in raw ground where the sprinklers are to be initially installed above the finished grade and lowered when new turf is established, the swing joint allows sprinkler repositioning without changing risers. This is a common and practical procedure which eliminates the problem of dirt being accidentally introduced into the lateral lines when a riser is changed.

2. Flush lines thoroughly prior to installing sprinkler.
3. Apply plumbingtape on riser threads (not required on ACME threads). Install sprinkler to riser and tighten.

▲ CAUTION: Use only plumbing tape on riser threads. Use of pipe dope or other types of sealing compounds can cause deterioration of sprinkler body threads.

Connecting Control Wires (Electric Models Only)

1. Route control wires to sprinklers. Provide extra wire at sprinkler to allow for height adjustment. One common wire and station wire is required for each sprinkler. See Wire Sizing Chart, **Table 1** for proper application.

Figure 1

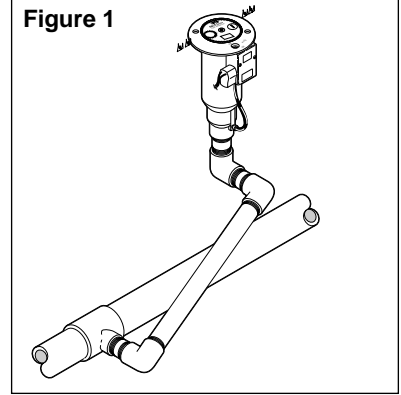

Table 1: Wire Sizing Chart

Voltage	AWG	mm ²	Voltage Drop	Circular Mills	Total Wire Length Between Controller and Sprinkler							
					1 Sprinkler		2 Sprinklers		3 Sprinklers		4 Sprinklers	
23	14/14	2.5/2.5	4	4100	6571'	2003 m	3285'	1001 m	2190'	668 m	1643'	501 m
23	14/12	2.5/4.0	4	5315	8518'	2596 m	4259'	1298 m	2839'	865 m	2129'	649 m
23	14/10	2.5/5.5	4	7250	11619'	3541 m	5809'	1771 m	3873'	1180 m	2905'	886 m
23	12/12	4.0/4.0	4	6530	10465'	3190 m	5232'	1595 m	3488'	1063 m	2616'	798 m
23	12/10	4.0/5.5	4	8465	13566'	4135 m	6783'	2067 m	4522'	1378 m	3391'	1034 m
23	12/8	4.0/7.0	4	11515	18454'	5625 m	9227'	2812 m	6151'	1875 m	4613'	1406 m
23	10/10	5.5/5.5	4	10400	16667'	5080 m	8333'	2540 m	5556'	1693 m	4167'	1270 m
24	14/14	2.5/2.5	5	4100	8213'	2503 m	4107'	1252 m	2738'	835 m	2053'	626 m
24	14/12	2.5/4.0	5	5315	10647'	3245 m	5324'	1623 m	3549'	1082 m	2662'	812 m
24	14/10	2.5/5.5	5	7250	14523'	4427 m	7262'	2213 m	4841'	1476 m	3631'	1107 m
24	12/12	4.0/4.0	5	6530	13081'	3987 m	6540'	1993 m	4360'	1329 m	3270'	997 m
24	12/10	4.0/5.5	5	8465	16957'	5168 m	8479'	2584 m	5652'	1723 m	4239'	1292 m
24	12/8	4.0/5.5	5	11515	23067'	7031 m	11533'	3515 m	7689'	2344 m	5767'	1758 m
24	10/10	5.5/5.5	5	10400	20833'	6350 m	10417'	3175 m	6944'	2117 m	5208'	1581 m

Note: Wire length data provided in **Table 1** is the sum of the station and common wire legs. See example in **Figure 2**.

2. Attach control wires to solenoid leads using an approved waterproof splicing method.

▲ CAUTION: All wire splices and field connections must be waterproofed to prevent short circuit to ground and subsequent controller damage.

Figure 2

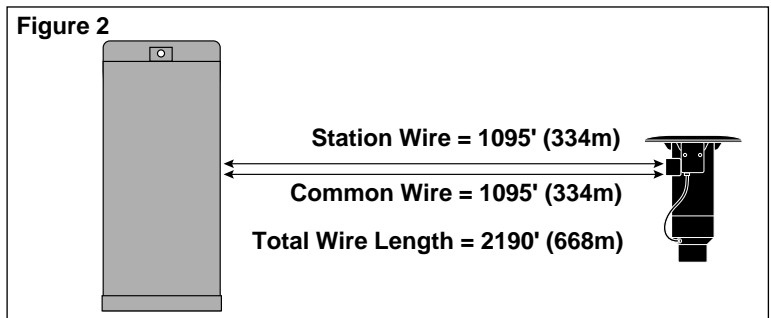

Connecting Hydraulic Control Tubing (Hydraulic Models Only)

- Route control tubing from the controller to the sprinkler location(s).

Note: Leave an 18" (45.7 cm) service loop of tubing at each sprinkler to facilitate movement of sprinkler and service operations. Refer to **Table 2** for tubing run length and sprinkler elevation information.

- Flush tubing thoroughly to remove all air and debris.
- Remove the tube retainer and poly cap from the tubing adapter at the base of the sprinkler.
- Slide the tube retainer over the end of the control tubing and attach tubing to adapter.
- Slide tube retainer over adapter area to secure tubing.

Table 2: Hydraulic Control Systems

Type of System*	Maximum Distance From Controller	Elevation Restrictions
Normally Open (01) with 3/16" Control Tubing	500'	Valve elevation should not exceed 25' ABOVE controller elevation or 70' BELOW controller elevation.
Normally Open (01) with 1/4" Control Tubing	1000'	Valve elevation should not exceed 25' ABOVE controller elevation or 70' BELOW controller elevation

- * All hydraulic connections on Toro valves are 1/4" insert type.
- Control line pressure must be equal to or greater than mainline pressure.
- Control line pressure range is 40 to 150 PSI.

System Start Up

The following is a recommended procedure that will protect system components during system start-up. The procedure is based on a velocity fill rate of less than 2' (.61 m) per second. See **Table 3** below.

Table 3: Recommended System Fill Rate

Pipe Size		Flow		Velocity		Pipe Size		Flow		Velocity	
in.	cm	GPM	LPM	ft/sec	m/sec	in.	cm	GPM	LPM	ft/sec	m/sec
1/2	1.3	2	7.6	1.60	0.49	3	7.6	45	170.3	1.86	0.57
3/4	1.9	3	11.4	1.92	0.59	4	10.1	75	283.9	1.87	0.57
1	2.5	5	18.9	1.50	0.46	6	15.2	150	567.8	1.73	0.53
1-1/4	3.1	10	37.9	1.86	0.57	8	20.2	250	946.3	1.70	0.52
1-1/2	3.8	10	37.9	1.41	0.43	10	25.4	450	1703.0	1.97	0.60
2	5.0	20	75.7	1.80	0.55	12	30.5	500	1893.0	1.55	0.47
2-1/2	6.4	30	113.6	1.84	0.56						

WARNING



NEVER STAND OR LEAN OVER THE SPRINKLER WHILE THE IRRIGATION SYSTEM IS BEING FILLED, DURING MANUAL OR AUTOMATIC OPERATION OR WHEN PERFORMING SPRINKLER SERVICE PROCEDURES. DIRECT CONTACT WITH IRRIGATION SPRAY, A FAILED OR IMPROPERLY INSTALLED SPRINKLER CONNECTION OR SPRINKLER COMPONENTS FORCIBLY EJECTED UPWARD UNDER PRESSURE CAN CAUSE SERIOUS INJURY.

- Use jockey pump only to fill the system at a velocity fill rate of less than 2' (0.61 m) per second.

⚠ CAUTION: Failure to comply with recommended fill rate will increase line pressure resulting in a water hammer effect that could damage sprinklers and piping components.

- Use quick coupler keys at all tees and greens with quick coupler valves to bleed air from the system lines during the filling process. For best results, do not compress air and then relieve it – bleed the air continuously while filling the system.
- After water has filled all lines and all air is removed, remove the quick coupler keys.

Arc Adjustment Procedure (Part-circle Models)

The 860S and 880S part-circle models have an adjustable watering arc from 30°–330° and are factory preset at 180°. The left side of the arc, located at the end of counterclockwise rotation, is non-adjustable (fixed). Therefore, all arc adjustments, whether increasing or decreasing, will change the right side of the arc, located at the end of clockwise rotation.

Although the sprinkler arc can be adjusted dry (sprinkler shut off), the best results are obtained during operation. The tools required for this procedure include a phillips screwdriver and an arc adjustment tool P/N 995-82 (or a 3/32" x 6" hex wrench).



WARNING

NEVER STAND OR LEAN OVER THE SPRINKLER WHILE THE IRRIGATION SYSTEM IS BEING FILLED, DURING MANUAL OR AUTOMATIC OPERATION OR WHEN PERFORMING SPRINKLER SERVICE PROCEDURES. DIRECT CONTACT WITH IRRIGATION SPRAY, A FAILED OR IMPROPERLY INSTALLED SPRINKLER CONNECTION OR SPRINKLER COMPONENTS FORCIBLY EJECTED UPWARD UNDER PRESSURE CAN CAUSE SERIOUS INJURY.

1. Operate the sprinkler. See **WARNING** above.

Note: During this procedure, water will discharge continuously from the threaded shaft.

2. To check the current arc setting, rotate the cap by hand **in the direction of current travel** to the end of the arc. Immediately rotate the cap in the reverse direction to the opposite end of the arc.
3. Rotate the cap to the left side of the arc. If only a slight adjustment (one-eighth of a turn or less) is required to align the spray with the left watering border, turn the sprinkler body. If more than one-eighth turn is required, remove the sprinkler drive assembly and reposition it in the body to achieve the proper alignment. Refer to the service procedures on page 9 for disassembly instructions.

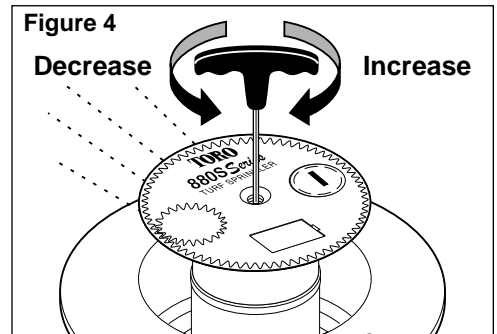
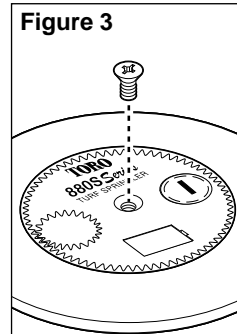

4. To adjust the arc, remove the phillips head screw from the center of the cap. See **Figure 3**.
 5. Insert arc adjustment tool (P/N 995-82) or a 3/32" x 6" hex wrench into threaded shaft. Turn the tool slowly **counterclockwise** to **decrease** the arc or **clockwise** to **increase** the arc as shown in **Figure 4**.
- Note:** Each "click" equals 1° of arc change. One complete revolution of the hex wrench results in a 75° change.
6. Repeat steps 2 and 5 as necessary, making small adjustments until exact arc is set.
 7. Install cap screw when arc adjustment is completed.

Pilot Valve Operation (Electric Models Only)

The main function of the pilot valve is to control the operation of the main valve located in the base of the sprinkler body. The main valve is operated by the release of water metered through the pilot valve when it is activated either manually at the sprinkler or by the irrigation system controller.

Another important function of the pilot valve is to regulate the water pressure to the sprinkler nozzle. Pressure regulation compensates for large variations within the system and maintains a constant pressure for optimum sprinkler operation. The pilot valve is factory set to regulate one of four pressure levels 50 psi (3.4 bar), 65 psi (4.5 bar), 80 psi (5.5 bar) or 100 PSI (6.9 bar).

The sprinkler operation mode is set using a Toro Selector Tool (P/N 995-15) inserted through the body flange onto the pilot valve D-shaped selector cam. The "AUTO" mode permits automatic operation from the system controller. The "ON" mode opens the main valve for manual operation and "OFF" mode prevents the main valve from opening.

Troubleshooting

Pilot Valve

PROBLEM	POSSIBLE CAUSE – CORRECTIVE ACTION
SPRINKLER WILL NOT TURN ON	(a) No 24 VAC to coil assembly. (Electric Models) – Measure voltage with a Digital Volt Meter (DVM). Check wiring and controller program. – Refer to Controller Operating Instructions.
	(b) Selector cam in "OFF" position. – Set to "AUTO" position.
	(c) Debris in pilot valve assembly. – Disassemble and remove all debris. (See Servicing Pilot Valve page 11.)
	(d) Insufficient pressure in controller supply line and/or sprinkler control tube. (N.C. Models) – Check pressure.

(continued)

SPRINKLER WILL NOT SHUT OFF

- (a) Constant 24 VAC from controller. (Electric Models)
 - Check for voltage using a DVM. If voltage is present, disconnect wire. If sprinkler closes, service controller. Refer to Controller Service Manual.
- (b) Selector cam in manual "ON" position.
 - Set to "AUTO" or "OFF" position.
- (c) Debris in pilot valve assembly.
 - Disassemble and remove all debris. (See Servicing Pilot Valve page 11.)
- (d) Constant pressure from controller. (N.C. Models)
 - Check pilot valve at controller for constant flow.
 - Check elevation differential. Valve elevation should not exceed 0' above controller elevation or 70' (21.3 m) below controller elevation.

Sprinkler Mechanism

PROBLEM

POSSIBLE CAUSE – CORRECTIVE ACTION

SPRINKLER WON'T ROTATE

- (a) Debris wedged between stator and turbine.
 - Remove obstruction.
- (b) Drive assembly defective.
 - Replace drive assembly.
- (c) Nozzle base assembly defective.
 - Replace nozzle base assembly.

HEAD STICKS UP

- (a) Dirt in riser assembly.
 - Flush out. (See Flushing Procedure on page 11.)
- (b) Damaged or missing return spring.
 - Replace.
- (c) Damaged riser.
 - Replace.

POOR DISTRIBUTION PATTERN

- (a) Nozzle plugged with debris.
 - Clean or replace nozzle.
- (b) Nozzle orifice damaged.
 - Replace nozzle.
- (c) Low operating pressure.
 - Determine why system overloaded and correct.

Main Valve

PROBLEM

POSSIBLE CAUSE – CORRECTIVE ACTION

VALVE WON'T CLOSE (Electric)

- (a) Continuous 24 VAC to sprinkler.
 - Check controller for voltage source.
- (b) Leak in pilot valve assembly.
 - Replace pilot valve assembly.
- (c) Plugged supply screen on piston.
 - Clean or replace screen.
- (d) Manual control selector on pilot valve assembly turned to "ON" position.
 - Turn to "AUTO" position.
- (e) Plunger movement restricted.
 - Inspect and clean or replace.
- (f) Valve cylinder misaligned with sprinkler body communication tube.
 - Remove valve assembly and install correctly.
- (g) Foreign object keeping valve from seating.
 - Remove, clean and check valve for damage. Replace if necessary.
- (h) Damaged piston seal or piston assembly.
 - Replace valve assembly.

VALVE WON'T CLOSE (Hydraulic)

- (a) Leak in control tubing.
 - Isolate and repair.
- (b) Pilot valve leak in controller.
 - Confirm by observing constant dripping from discharge line of controller. Refer to Controller Service Manual.
- (c) Valve cylinder misaligned with sprinkler body communication tube.
 - Remove valve assembly and install correctly.
- (d) Foreign object keeping valve from seating.
 - Remove, clean and check valve for damage. Replace if necessary.
- (e) Damaged piston seal or piston assembly.
 - Replace valve assembly.

**VALVE WON'T OPEN
(Electric)**

- (a) Control (field) wires severed.
 - Isolate and repair.
- (b) No power to controller.
 - Establish controller power.
- (c) No power from controller to solenoid.
 - Check for blown fuse and replace.
- (d) Manual control selector on pilot valve assembly turned to "OFF" position.
 - Turn to "AUTO" position.
- (e) Pilot valve solenoid inoperative.
 - Remove and replace.
- (f) Pilot valve plunger movement restricted.
 - Inspect, clean and/or replace.
- (g) No supply from main valve.
 - Debris in control tube, main valve assembly and/or communication passages in body. Flush thoroughly.

**VALVE WON'T OPEN
(Hydraulic)**

- (a) Plugged controller discharge line or discharge port in pilot valve.
 - Verify by checking for discharge at discharge line when station is activated. If no discharge, refer to Controller Service Manual.

**SPRINKLER WEEPING
(Slow leak in valve)**

- (a) Damaged or blocked valve seat.
 - Remove blockage and, if necessary, replace valve assembly.
- (b) Damaged piston seal or piston assembly.
 - Replace valve assembly.
- (c) Low pressure on supply line .
 - Check for low pressure reason and correct.
- (d) Elevation of normally closed sprinkler exceeds 75' (22.9 m) differential.

**SEVERAL VALVES ON DIFFERENT
STATIONS FAIL TO CLOSE
(Hydraulic)**

- (a) Control tubing leak which lowers supply pressure to other stations.
 - Turn controller from station to station until a station is reached where only valves on that station stay open. The leak would be in the tubing on that station. Isolate and repair.
- (b) Leak in supply line to controller.
 - Verify by checking pressure in all control lines.
- (c) Leak in controller pilot valve.
 - Verify by constant discharge from controller.
- (d) Plugged supply line filter.
 - Replace filter if more than 3 psi (0.21 bar) differential exists.

Service Procedures

Servicing Sprinkler Mechanism



WARNING

NEVER STAND OR LEAN OVER THE SPRINKLER WHILE THE IRRIGATION SYSTEM IS BEING FILLED, DURING MANUAL OR AUTOMATIC OPERATION OR WHEN PERFORMING SPRINKLER SERVICE PROCEDURES. DIRECT CONTACT WITH IRRIGATION SPRAY, A FAILED OR IMPROPERLY INSTALLED SPRINKLER CONNECTION OR SPRINKLER COMPONENTS FORCIBLY EJECTED UPWARD UNDER PRESSURE CAN CAUSE SERIOUS INJURY.

1. Remove the cap screw (1) and cap (3).

Note: During reassembly, ensure the cap is correctly installed with the Toro Logo positioned over the main nozzle (10).

2. Insert hooked end of multi-purpose tool (P/N 996-83) into slot in snap ring (13). Pull snap ring inward toward sprinkler assembly, then upward to remove from groove.

Note: During reassembly, ensure snap ring is correctly installed and fully seated in groove.

3. Insert hooked end of multi-purpose tool into slot provided in the nozzle base above main nozzle. Pull riser assembly out of body.
4. While pushing seal/retainer assembly (14 and 15) downward to slightly compress return spring, use a 1/2" nut driver (P/N995-80) to remove nozzle base lock nut (8). Pull nozzle base assembly from drive assembly shaft.
5. **Slowly** release tension from return spring.
6. Remove the slotted stainless steel washer (7).
7. Three small tabs are provided on the edge of the multi-purpose tool. Insert tabs into debris filter screen. Holding plastic base of riser assembly, turn screen counterclockwise to remove.
8. Remove variable stator and stator support from riser assembly.
Note: The stator support is keyed to the riser assembly. During reassembly, ensure stator support slots engage riser assembly alignment tabs. Refer to **Figure 7** for the location of the alignment tabs.
9. Using a 5/8" nut driver (P/N 995-99), unscrew main nozzle from nozzle base assembly.
10. Using a 7/16" nut driver (P/N 995-79), unscrew two inner nozzles from nozzle base assembly. Remove restrictor from one inner nozzle.
11. Pressing only on the ribbed area of drive assembly, push the drive assembly out of riser assembly as shown in **Figure 6**

CAUTION: When removing or installing the drive assembly, **DO NOT** press on the threaded shaft or attempt to pull the drive assembly out of riser assembly. Push on the ribbed areas only! Failure to comply may cause separation of drive assembly components.

Note: The drive assembly is keyed to the riser assembly. During reassembly, position the extra rib of the drive assembly to the right of either alignment tab of the riser assembly as shown in **Figure 7**.

12. Thoroughly clean and inspect all parts and replace as necessary. Reassemble in the reverse order.

Figure 5

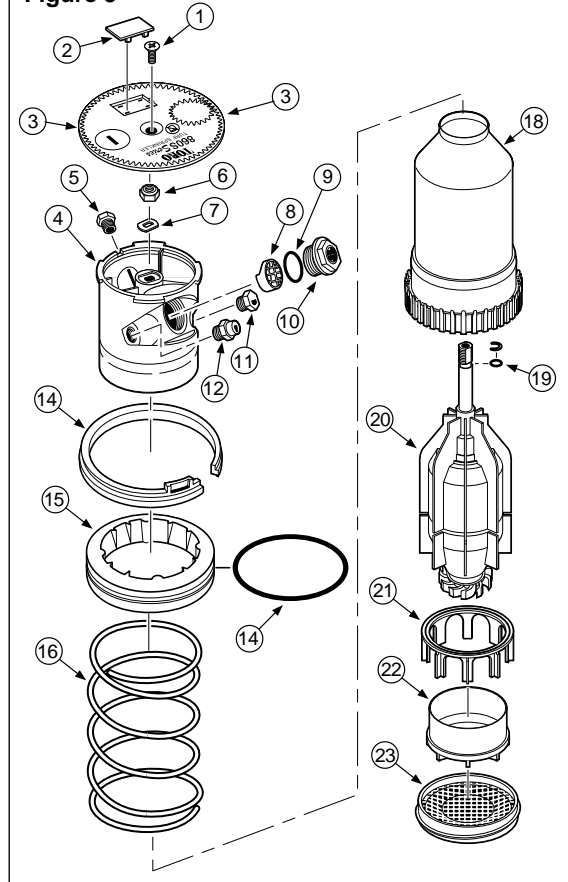

Figure 6

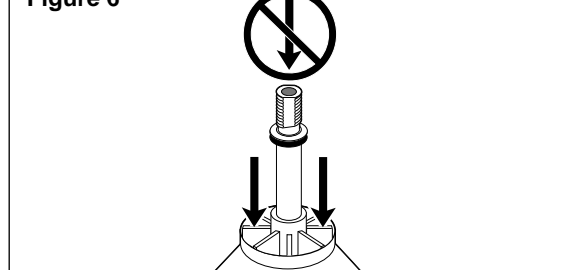
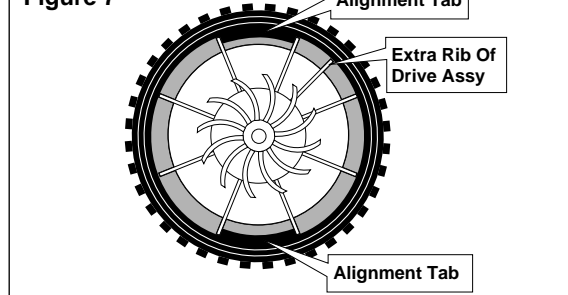

Figure 7



Servicing Main Valve

WARNING



IF THE VALVE SNAP RING IS DIFFICULT TO REMOVE, RESIDUAL WATER PRESSURE MAY BE REMAINING IN THE SYSTEM. TO PREVENT POSSIBLE SERIOUS INJURY DUE TO VALVE BEING EJECTED UPWARD UNDER PRESSURE, CONFIRM THE FOLLOWING CONDITIONS EXIST PRIOR TO REMOVING THE SNAP RING AND VALVE:

- A. WATER SUPPLY TO SPRINKLER IS SHUT OFF AT SOURCE.
- B. ALL PRESSURE IS BLED FROM SYSTEM, INCLUDING CONTROL TUBES.
- C. AC POWER IS DISCONNECTED AT SOURCE.

1. See **Warning** above. To remove valve assembly, squeeze snap ring ears together with snap ring pliers (P/N 995-100) and remove snap ring from sprinkler body. See **Figure 8**
2. Use valve removal tool P/N 995-08 for 860S or 995-09 for 880S to remove valve assembly from base of sprinkler body. Valve removal tool is inserted into sprinkler body and pushed through valve ribs. A slight twist will catch tool under ribs enabling valve removal by pulling straight up and out. See **Figure 9**.

Note: If valve removal tool is not available, use snap ring pliers to grasp rib of valve cylinder assembly and pull up and out of sprinkler body.

3. Reinstall valve assembly using valve insertion tool P/N 995-76 for 860S or 995-101 for 880S as follows:

- Load snap ring onto insertion tool carrier with **stepped side** against carrier as shown in **Figure 10**. While holding snap ring in compressed position, slide retainer clip in to hold snap ring ears
- Load valve assembly on carrier as shown.
- Locate position of communication tube in bottom of sprinkler body and orient insertion tool accordingly.
- Insert tool straight down into sprinkler body aligning bosses on t-handle with holes on sprinkler body flange. When valve assembly clears vertical side wall ribs inside body, pull up on snap ring release mechanism (880 models only) and press valve assembly into position. Snap ring will lock into groove when properly installed. Remove insertion tool and check snap ring to confirm that it is fully seated in groove

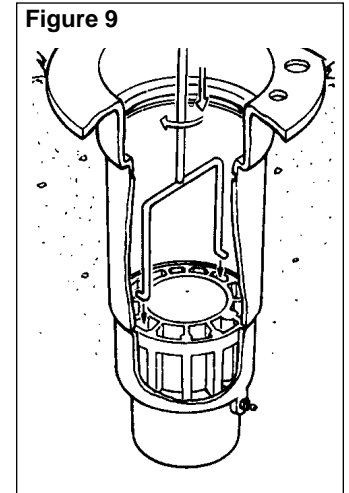
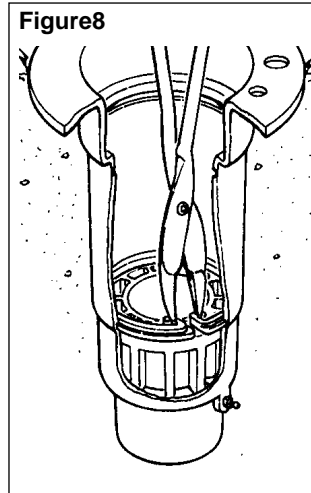
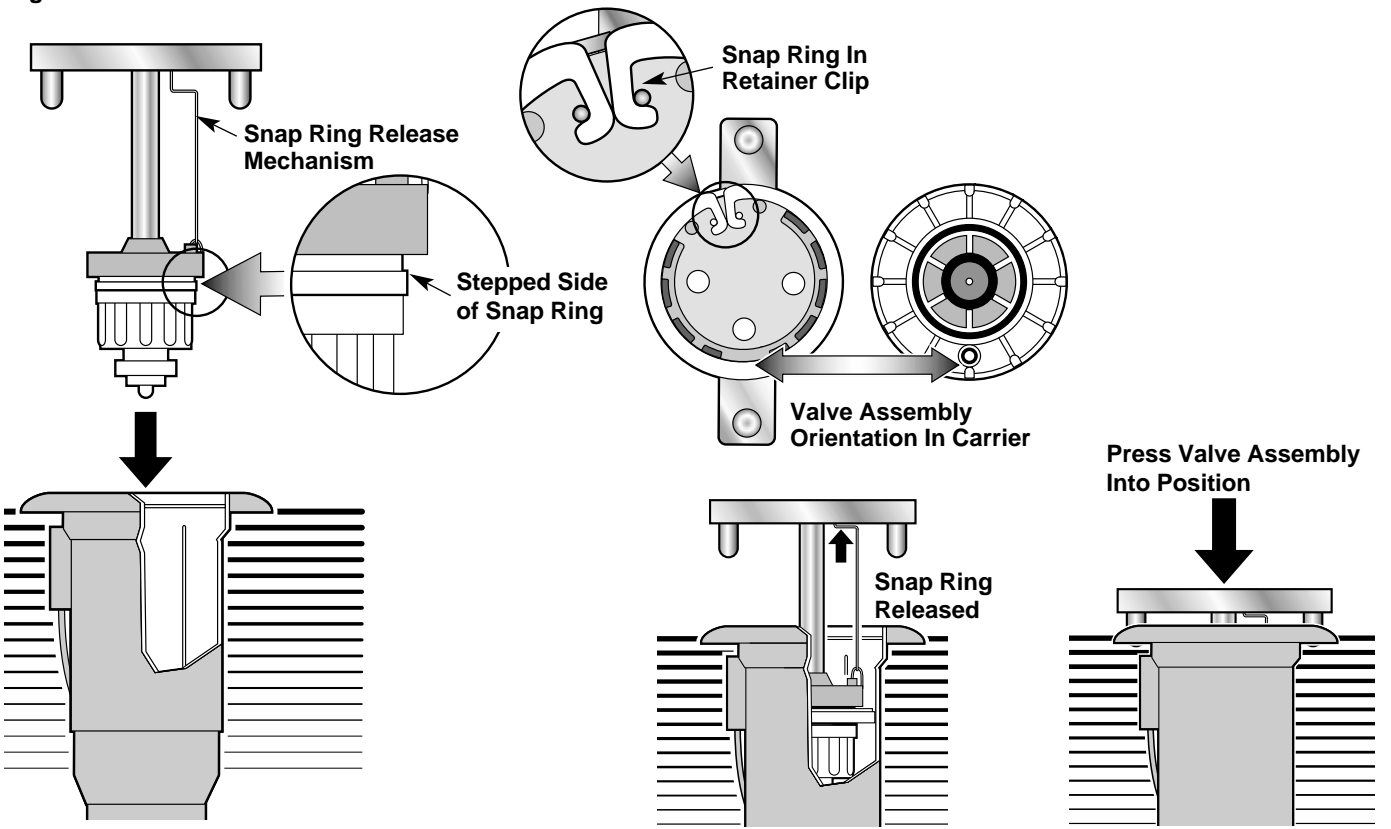

Figure 10



Servicing Pilot Valve

WARNING

NEVER STAND OR LEAN OVER THE SPRINKLER WHILE THE IRRIGATION SYSTEM IS BEING FILLED, DURING MANUAL OR AUTOMATIC OPERATION OR WHEN PERFORMING SPRINKLER SERVICE PROCEDURES. DIRECT CONTACT WITH IRRIGATION SPRAY, A FAILED OR IMPROPERLY INSTALLED SPRINKLER CONNECTION OR SPRINKLER COMPONENTS FORCIBLY EJECTED UPWARD UNDER PRESSURE CAN CAUSE SERIOUS INJURY.

Note: Refer to **Figure 11** for the following procedure.

1. Make sure that the water supply to sprinkler is positively shut off and any residual pressure has been bled off. If the sprinkler is pressurized, main valve will open when the pilot valve is disconnected from control tube.
2. Carefully remove turf and soil from side of sprinkler to expose pilot valve and control tubing.
3. Remove two retaining screws from the pilot valve housing (1).
4. Pull the pilot valve assembly away from the sprinkler body and cut the control tubing just below tube retainer. Unless pilot valve has been previously removed, control tubing length will be sufficient for re-connection.
5. Remove tube retainer and remaining piece of control tubing from valve body fitting.
8. Pull pilot valve body assembly out of housing.
6. Remove solenoid (2) by turning it counterclockwise.
7. Remove selector shaft assembly (6) and plunger assembly (3). (The selector shaft retains the plunger in the valve body.)
9. Remove diaphragm assembly (10), piston (9), spring (8) and o-ring (4).
10. Thoroughly clean and inspect all parts. Replace damaged parts as necessary and reassemble in reverse order.

Note: Refer to Illustrated Parts Breakout Book, form number 368-0044 for service part numbers.

Figure 11

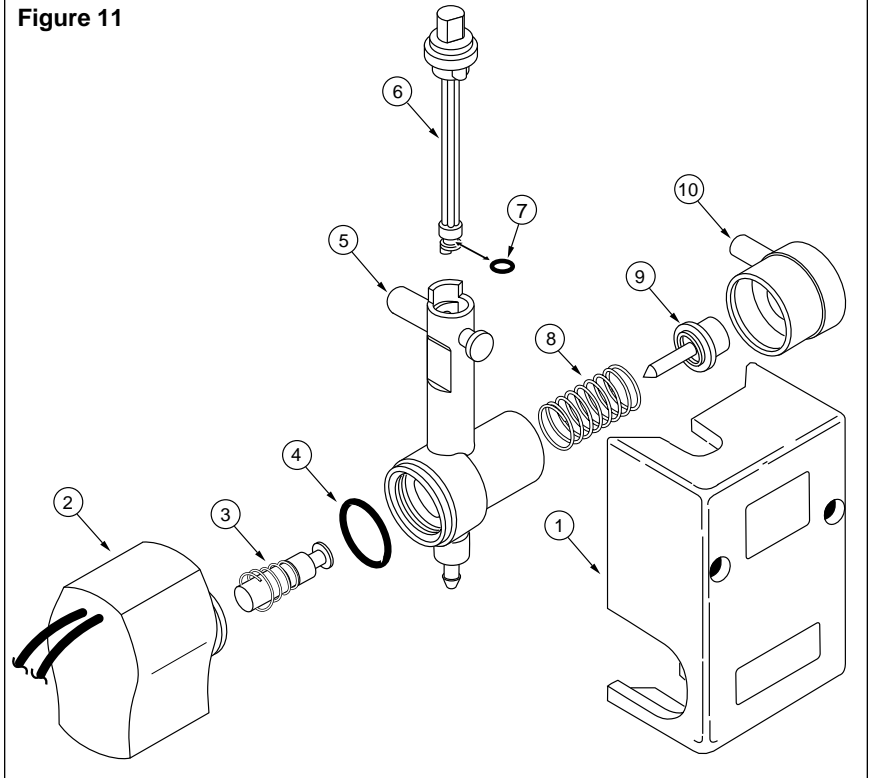

Flushing Sprinkler

WARNING

NEVER STAND OR LEAN OVER THE SPRINKLER WHILE THE IRRIGATION SYSTEM IS BEING FILLED, DURING MANUAL OR AUTOMATIC OPERATION OR WHEN PERFORMING SPRINKLER SERVICE PROCEDURES. DIRECT CONTACT WITH IRRIGATION SPRAY, A FAILED OR IMPROPERLY INSTALLED SPRINKLER CONNECTION OR SPRINKLER COMPONENTS FORCIBLY EJECTED UPWARD UNDER PRESSURE CAN CAUSE SERIOUS INJURY.

1. With sprinkler operating, carefully step down on center of cap several times. Water will flow around riser and flush out debris.
2. Cycle sprinkler on and off several times to check for proper retraction. Cap should be even with top of body flange when fully retracted. If riser sticks in up position, check for debris lodged between riser and body. Flush out all debris. Remove sprinkler mechanism if necessary.

Free Manuals Download Website

<http://myh66.com>

<http://usermanuals.us>

<http://www.somanuals.com>

<http://www.4manuals.cc>

<http://www.manual-lib.com>

<http://www.404manual.com>

<http://www.luxmanual.com>

<http://aubethermostatmanual.com>

Golf course search by state

<http://golfingnear.com>

Email search by domain

<http://emailbydomain.com>

Auto manuals search

<http://auto.somanuals.com>

TV manuals search

<http://tv.somanuals.com>