

TOSHIBA

DISK PRODUCTS DIVISION

XM-7002B

CD-ROM DRIVE

PRODUCT SPECIFICATION

JUNE 1999
Rev. 1.0

Specifications are subject to change without notice

DOCUMENT NUMBER
12095

Notice

1. This product has no over-current protection circuit.
System should have appropriate over-current protection.
Toshiba Corporation makes no warranty of damages caused by no over-current protection.
2. This has a little possibility of errors.
To prevent damages and injury caused by the above, careful consideration for the safety and integrity should be taken in the system design.
Do not use this product in a system that may cause hazard to human being or material loss caused by the failure, loss of data and/or errors of this product.
3. Do not disassemble or modify this product.
Or, reliability, safety and performance can not be guaranteed.
4. Turn off the system power before mounting/removing this product.
Or, it may cause failure or damage.
5. Because the Interface connector of this product allows insertion of only one side direction, ascertain direction carefully to insert the connector.
6. To built this product in an equipment, handle it only in electrostatically safe environment.
Do not touch connecting terminal directly or the product may be damaged by electrostatic energy.
7. This product can playback discs based on the format described in item 3.1.(1). Do not load a disc which is not based on the item (discs of which outside is cut unevenly and is not a normal circle, etc.) or a disc with its weight unbalanced excessively.
A very high speed rotation is carried out inside the product, so abnormal vibration and malfunction may occur if disc described above is loaded.
8. When a disc cannot be ejected because of same troubles, etc., turn off the unit and eject the disc using the emergency eject mechanism after passing more than 1 minute.
When the emergency eject is carried out while the power is on or immediately after the power off, the disc may be eject in a rotating status. We do not assure if the disc is damaged by this.
9. Do not apply excessive force during the eject operation. The disc load inside the product may be ejected in a rotating status.
Should the disc be damaged by the above action, we do not warranty against that.
10. In the instruction manual of your product, statement described in "Safety Instruction Manual "attached to this product, the statement of item 2 and 8 above, and other required statements should be mentioned for thorough understanding by the users.

Contents

1. Introduction	1
2. Features	2
3. Specifications	3
3.1. Performance	3
3.2. Environmental Conditions	5
3.2.1. Temperature and Humidity	5
3.2.2. Dusu and Dirt	5
3.2.3. Vibration	5
3.2.4. Atmospheric Pressure and Altitude	5
3.2.5. Shock	6
3.3. Installation Conditions	6
3.3.1. Equipment	6
3.3.2. Installation	6
3.3.3. Back side	7
3.3.4. Vibration detection	8
3.4. Dimensions and Weight	8
3.5. Reliability	10
3.5.1. Error Rate	10
3.5.2. MTBF	10
3.5.3. MTTR	10
3.5.4. Drive Life	10
3.5.5. Mechanical Life	10
4. Configuration	10
4.1. Electrical Parts	10
4.2. Optical Pickup	10
4.3. Spindle Motor	10
4.4. Feed Motor	10
5. Functions	12
5.1. CD-ROM Data Configurations	12
5.2. Power ON/OFF Timing	12
5.3. Standby mode	13
6. Interface	13
6.1. I/O cable	13
6.2. Signal summary	13
6.2.1. Signal Specifications	14
6.2.2. Timing of Host Interface(PIO)	15
6.2.3. Timing of Host Interface(DMA Multi)	16
6.2.4. Timing of Host Interface(Ultra DMA)	17
6.3. Connector	18
6.4. Suppor Commmand List	19
6.4.1. ATAPI Packet Command for CD-ROM Device	19
6.4.2. ATA Commandfor ATAPI CD-ROM Device	20

7. Power Requirements	21
7.1. Source Voltage	21
7.1.1. Spike	21
7.1.2. Ripple	21
7.2. Current Drain	21
7.2.1. Sleep	21
7.2.2. Standby	21
7.2.3. Idle	21
7.2.4. Continuous Read	21
7.2.5. Average	21
7.2.6. Maximum	21
7.2.7. Peak in executing Access	21
7.2.8. Peak Current	21
8. Audio	21
8.1. Line Output	21
8.1.1. Audio Cable	21
8.1.2. Connector	22
8.2. Audio Modes	22
9. Device Configuration	22
9.1 Master mode setting	22
9.2 Slave mode setting	22
10. Busy Indicator	23
11. Maintenance	24
11.1. Disc	24
11.2. Optical Pickup	24
12. Emergency Eject	24
13. Safety Standards/Agency Approvals	24
14. Electrostatic Discharge	25
15. Accessories	25
16. Packaging	25
17. CE Declaration of conformity	25

1. Introduction

This document describes Toshiba's XM-7002B CD-ROM Drive.

This drive reads digital data stored on CD-ROM and CD-Audio discs.

The CD-ROM disc is single sided and has a 12 cm or 8 cm diameter. It typically contains approximately 600 MBytes or 200 MBytes of information respectively. (1 MByte= 2^{20} Bytes)

This drive reads digital data stored on CD-ROM discs at maximum 24 times faster rotational speed.

This drive is a new generation drive with highest performance such as 95 ms (target) access Time.

This drive shows highest performance such as 60,000 hour MTBF.

This drive offer long life and high durability because the disc is read by a LASER, thereby eliminating physical contact with the disc.

This drive support ATAPI (ATA Packet interface) Revision 2.6 spec. and SFF8090 Version 2 (Mt. Fuji Commands for CD and DVD-Devices) of CD/DVD Command.

2. Features

- (1) Lightening by All Aluminum Cabinet Structure (180 g)
- (2) 12.7 mm Height
- (3) Support 12 cm/8 cm CD-ROM Disc Drive
- (4) Rotational speed can be controlled by command
Max.24 (Ave.17X), Max.20X (Ave.14X), Max.16X (Ave.11X), Max.10X (Ave.7X)
- (5) 95 ms (target) Random Access Time (Max.24X)
- (6) Max.3,600 KBytes/s (Ave. 2,550 KBytes/s) Sustained Data Transfer Rate
- (7) 5 V Single Voltage Source
- (8) Support Multisession Disc (Photo-CD, CD EXTRA), CD-R, CD-RW, CD-Text
- (9) Support Multimedia PC-3 Spec.
- (10) Support Windows PC98 Spec.
- (11) Support ACPI Spec.
- (12) Drawer Type Manual Load /Electrical Release
- (13) Emergency Eject
- (14) Built-in ATAPI Interface Controller
- (15) Support < CD-DA Transfer Over ATAPI >Function
- (16) Sub code P Thru W Transfer over ATAPI Bus
- (17) Built-in MODE-1 ECC/EDC
- (18) Embedded CD-ROM XA type ECC/EDC (in addition to standard type ECC/EDC)
- (19) Efficient Data Transmission Throughput via large 128 KBytes Buffer Memory and Buffer Algorithm
- (20) 8X Sampling & Digital Filter for CD Audio
- (21) Low Power Consumption. (Typ. 3.2 W) (20% Duty Random Access)
- (22) 16-Mode Output for CD Audio
- (23) Software Volume Control via ATAPI Mode Select Command
- (24) MTBF 60,000 POH
- (25) Data Transfer Rate
PIO Mode 4 (Data Transfer Rate 16.7 MB/s)
DMA: DMA Multi Word Transfer Rate Mode 2
: Ultra DMA Transfer Rate Mode 2
- (26) Support Vibration Detect Function

3. Specifications

3.1. Performance

(1) Applicable Disc Format*1	Red-Book, Yellow-Book, CD-ROM XA, CD-IBridge (Photo-CD, Video CD), CD-I, CD-I Ready, CD-G and Multisession (Photo-CD, CD EXTRA), CD-RW, CD-R, CD-TEXT
(2) Data Capacity(Yellow-Book) User Data/Block	2,048 Byte/block(Mode 1) 2,336 Byte/block(Mode 2 Form 2)
(3) Rotational Speed*2	Approx. 2,180 rpm (4.4-10X) Approx. 5,200 rpm (10.3-24X)
(4) Transfer Rate (1 KByte=2 ¹⁰ Byte=1,024 Bytes, 1 Mbyte=2 ²⁰ Byte=1,048,576 Bytes)	
Block Transfer Rate	Approx. 330-750 Block/s (4.4-10X) Approx. 772-1,800 Block/s (10.3-24X)
Data Transfer Rate (Yellow-Book Mode 1)	Approx. 660-1,500 KByte/s (4.4-10X) Approx. 1,545-3,600 KByte/s (10.3-24X)
(Yellow-Book Mode 2)	Approx. 752-1,710 KByte/s (4.4-10X) Approx. 1,716-4,104 KByte/s (10.3-24X)
Burst(ATAPI Interface)	16.7 MBytes/s (PIO Mode 4) 16.7 MByte/s (DMA multi word Mode2) 33.3 MByte/s (ULTRA DMA Mode2)

(5) Access Time (Typ.)	
Average Random Access Time*3	95 ms (Max.24X) 110 ms (10X)
Average Random Seek Time*4	90 ms (Max.24X) 100 ms (10X)
Average Full Stroke Access Time*5	180 ms (Max.24X) 200 ms (10X)

*1: All CD formats, except CD Red book (audio), require additional application specific software and/or hardware. The CD-ROM drive referenced in the specification is capable of reading these data formats. However, in order to run applications that use these formats you must first have the required software and/or hardware.

*2: Max 10X rotational speed is fixed for CD-audio (Red-Book), CD-RW, VIDEO-CD format. For the other Formats, it is Max.24X speed but 20X or 16X speed is selectable by command.

*3: Measured by performing multiple accesses which means reads of data blocks over whole area of the media from 00 min. 02 sec. 00 block to 60 min. 01 sec. 74 block more than 3000 times. Includes positioning, setting, latency time and ECC implementation time (if required).

*4: Measured by performing multiple accesses which means seeks of data blocks over whole area of the media from 00 min. 02 sec. 00 block to 60 min. 01 sec. 74 block more than 3000 times. Includes positioning, setting time which is same definition as HDD.

*5: Measured by performing multiple maximum accesses which means reads of data blocks from 00 min. 02 sec. 00 block to 60 min. 01 sec. 74 block more than 100 times. Includes positioning, setting, latency time and ECC implementation time (if required). Typ. value is for the average drive.

(6) Spin up Time (Focus Search Time and Disc Motor Start up Time)(Typ.)	
	2.8 s (Max.24X) 2.2 s (Max.10X)

(7) Data Buffer Capacity	128 KBytes
--------------------------	------------

(8) Load/Eject	1. Manual Load/Electrical Release (Eject Button) 2. Software Release (ATAPI command) 3. Emergency Eject
----------------	--

(9) Air Flow	Not Required
--------------	--------------

(10) Acoustic Noise	Less than 40 dB (with A weighted/Average) at 1 meter of Front Bezel Operation mode:Full stroke Access
---------------------	--

(11) Power Supply	+5 V(details in Section 7)
-------------------	----------------------------

3.2. Environmental Condition

This drive should be used under the conditions listed below.

3.2.1. Temperature and Humidity

(1) Operating Temperature	5 °C to 50 °C Max 60 °C (on the bottom center of cabinet)
(2) Storage Temperature	-20 °C to 65 °C
(3) Shipping Temperature(Packaged)	-40 °C to 65 °C
(4) Operating Temperature Gradient	11 °C/h (max)
(5) Storage Temperature Gradient	20 °C/h (max)
(6) Shipping Temperature Gradient	20 °C/h (max)
(7) Operating Humidity	8 % to 80 % (wet bulb 27 °C max)
(8) Storage Humidity	5 % to 95 %
(9) Shipping Humidity	5 % to 95 %
(10) Condensation	In all the above conditions there must be no condensation.

3.2.2. Dust and Dirt

Unspecified

3.2.3. Vibration

(1) Operating(1 Oct/min)	-- no hard error -- 5 to 500 Hz 2.45 m/s ² [0.25 G] (0-p) excluding resonance point
(2) Non-operating(1 Oct/min)	---no damage --- 5 to 500 Hz 9.8 m/s ² [1 G] (0-p)
(3) Shipping(Packaged)(1 Oct/min)	---no damage --- 5 to 500 Hz 14.7 m/s ² [1.5 G] (0-p) XYZ/30 min each

3.2.4. Atmospheric Pressure and Altitude

(1) Operating	0 to 3,000 m
(2) Shipping	0 to 12,000 m

3.2.5. Shock

- | | |
|--|---|
| (1) Operating (24X) | <p>---no hard error ---
 14.7 m/s² [1.5 G]
 (Half sine wave 11 ms/10s interval)
 ---data read recoverable---
 98 m/s² [10 G]
 (Half sine wave 11 ms/10s interval)</p> |
| (2) Non-operating(with no CD-Disc mounted) | <p>---no damage ---
 490 m/s² [50 G] (Half sine wave 11 ms)
 980 m/s² [100 G] (Half sine wave 3 ms)</p> |
| (3) Drop(Packaged) | <p>---no damage ---</p> |
| (a) Bulk Package (25 pcs) | 1 drop at 0.4 m (Bottom side only) |
| (b) Bulk Package (20 pcs) | 0.6 m drop once for each 6-surface, 1-edge and 1-corner |

3.3. Installation Conditions

Mounting: Horizontally within back and front +/-15 °
 Horizontally within right and left +/-15 °
 Vertical 30 ° / 15 °
 (See Figure 1)

3.3.1. Equipment

- (1) When mounting the equipment, use four M2-PO.4 tapping holes located on the left and right sides of the equipment.
 M2-P 0.4 screws' tolerance is rgulated by ISO 965/2. (ISO general purpose metric screw threads - Tolerance - Part 2: Limits of sizes for general purpose bolt and nut threads Medium quality)
- (2) The opposite surface of the bearing surface (fitting surface when mounting) of the tapping holes must be kept flat so that the bearing surface can be fit evenly.
****** When mounting the equipment using the tapping holes on the equipment side, it is recommended that the width of the minuting surface on left and right should be 102.8 +0.2/-0.
- (3) Use the mounting screws which do not enter deeply inside the equipment more specified value. The recommended screw tightening depth is;
 Left side: 2.2 mm - 2.5 mm.
 Right side: 1.2 mm - 1.5 mm.
- (4) When mounting the equipment, the tightening torque of four screws must be even.
 The recommended screw tightening torque is 0.2 Nm.

3.3.2. Installation

- (1) The mounting surface of the equipment must keep good flatness.
 When mounting, care should be paid that an excessive force which may caused torsional distortion on the equipment does not applied to the equipment. The recommended surface flatness for the mounting surface should be less 0.2 mm.
- (2) Install the equipment with enough space as much as possible in all directions around the equipment. Care should be paid that the equipment does not touch with peripheral instruments even if vibration, mechanical shock, etc. are applied to the equipment.
 For the maximum dimension of the equipment thickness (12.9 mm), it is recommended that a clearance more than 0.5 mm should be left the thickness direction.
 For the clearance around the front bezel, it is recommended that the clearance more than 0.8 mm should be left in all directions.

- (3) Care should be especially paid for the heat effect. Keep the air ventilation and shut out heat from the environmental condition. Then, install the equipment where the environmental temperature around the equipment does not exceed 50 °C.
- (4) Do not add the force beyond the recommended value on the top and bottom cover of the equipment. (The recommended value range for the top cover is shown in the under Figure 2) (For the bottom cover, the recommended value should be less than 2N on all areas.)

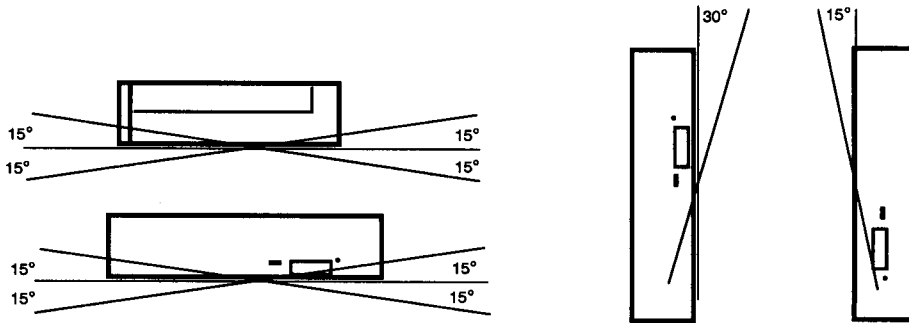

Figure 1

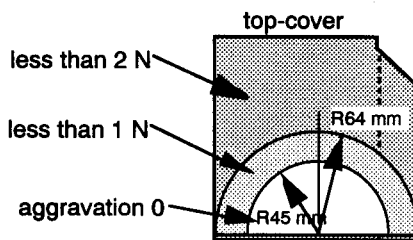

Figure 2

3.3.3.Back side

The screw holes for mounting exclusive connectors and connector boxes by customers are provided on the back side of the equipment.

When using the screw holes, following care should be paid.

- (1) When mounting, use M2-0.4 tapping holes. Care should be paid that an excessive force which may cause torsional distortion on the equipment does not applied to the equipment. M2-P 0.4 screws' tolerance is rgulated by ISO 965/2. (ISO general purpose metric screw threads - Tolerance - Part 2: Limits of sizes for general purpose bolt and nut threads Mediumquality).
The recommend flatness of the equipment mounting surface should be less than 0.2 mm. Install the equipment with enough space as much as possible in all directions around the equipment. Care should be paid that the equipment does not touch with peripheral instruments even if vibration, mechanical shock, etc. are applied to the equipment.
- (2) The opposite surface of the bearing surface (fitting surface when mounting) of the tapping holes must be kept flat so that the bearing surface can be fit evenly.
- (3) Use the mounting screws which do not enter deeply inside the equipment more than specified value. The recommended screw tightening depth is 2.2 mm - 2.5 mm.
- (4) When mounting the equipment, the tightening torque of screws must be even. The recommended screw tightening torque is 0.2 Nm.
- (5) After mounting the connector, do not apply excessive force to the connector in horizontal and/or vertical direction, force to twist or press.

3.3.4. Vibration detection

(1) This drive detects vibration which occurs when unbalanced disc is played, and rotation speed of two steps (16X, 10X) is selected according to the vibration level and the rotation speed is dropped automatically.
It is necessary to mount the drive stably in PC to detect the vibration correctly.

(2) This drive was tuned up to detect the vibration on the assumption that the drive was mounted in Toshiba DynaBook Satellite Pro 440 series.

Mounting condition in Toshiba DynaBook Satellite Pro 440 series is shown in Figure 3.

There will be possibility that the drive does not detect the vibration. It depends on mounting condition.

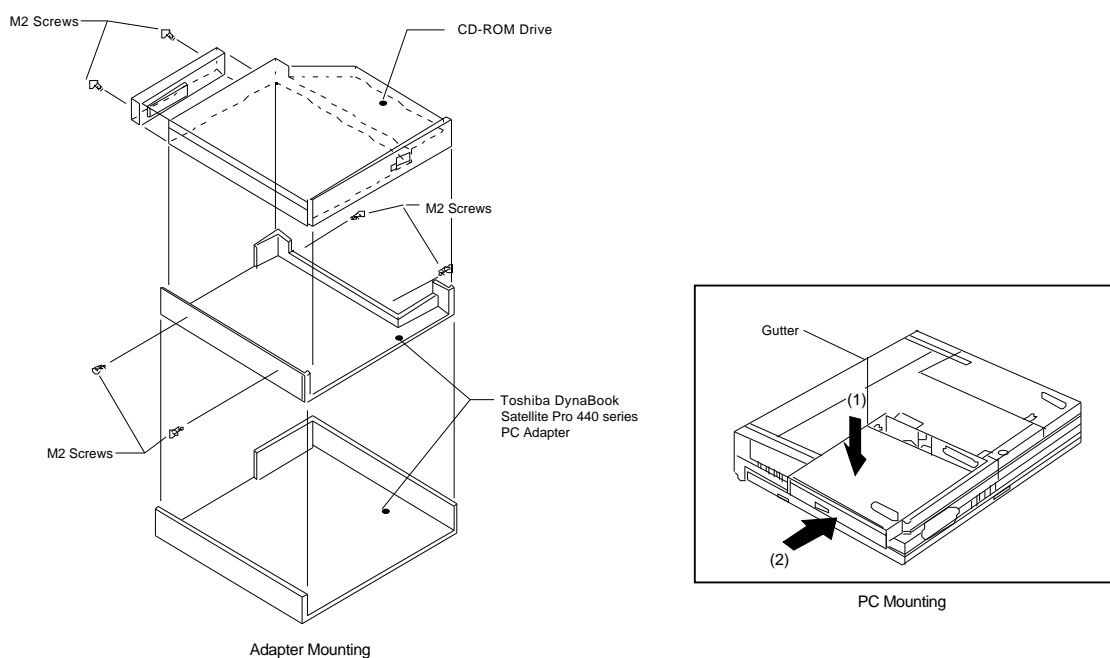

Figure 3

3.4. Dimensions and Weight

(1) External Dimensions (W x H x D)

---See Figure 4 for details---

128.0 mm x 12.7 mm x 129.0 mm

(2) Mass (Weight)

0.18 kg (Net)

233 kg (36 Bulk Packaged on one pallet)

135 kg (24 Bulk Packaged on one pallet)

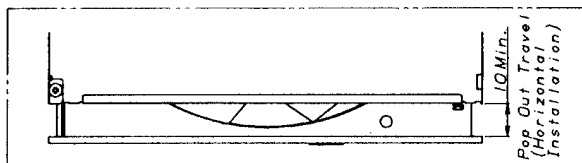
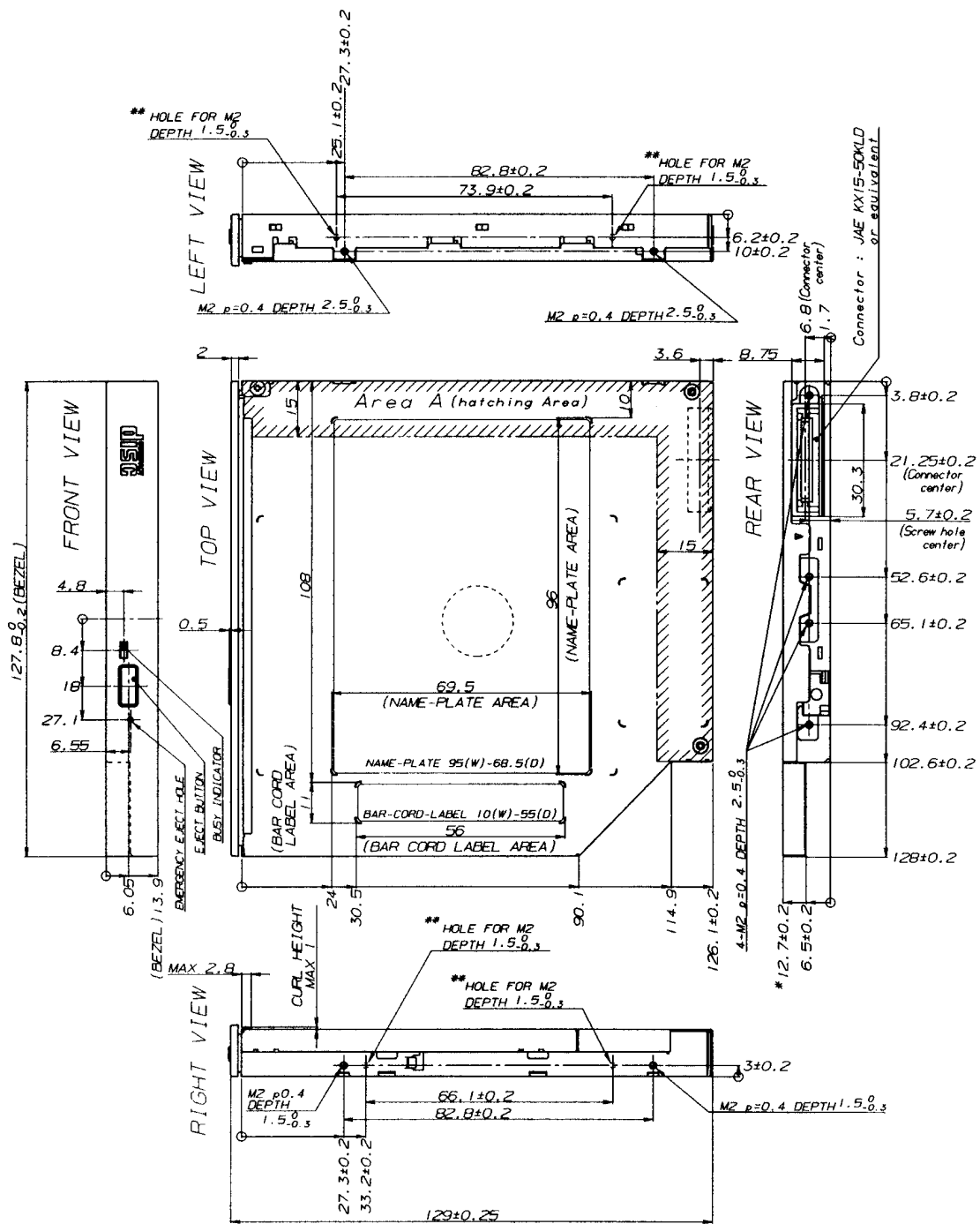

* Area A thickness is 12.7±0.2.
 Other area thickness is 12.7±0.5.
 (It doesn't include the thickness of a name-plate.)
 Drives can go through the gate of 12.95 height with force less than 2.94 N.

** Screw holes are option.
 (There's no hole on the standard drive.)

(Unit:mm)

Figure 4 External Dimensions

3.5. Reliability

3.5.1. Error Rate

(1) Hard Read Error Rate (Byte Error Rate) ----- Allowing 10 Retries -----
 Yellow-Book Mode 1/Mode 2 Form1 10⁻¹⁵ Max
 Yellow-Book Mode 2/Mode 2 Form2 10⁻¹² Max

(2) Seek Error Rate ---Allowing Retries---
 10⁻⁶ Max

3.5.2. MTBF

Assumptions: Power On Hours 60,000 POH
 On/Off Cycles 5,436 h/year
 Number of Access 312 cycles/year
 Operating Duty Cycle 600,000 accesses/year
 20 % of Power On Time
 (Reading/Seeking)

3.5.3. MTTR

0.5 h

3.5.4. Drive Life

15,000 h or 5 years(earlier one)

3.5.5. Mechanical Life

(1) Drawer Load/Eject 10,000 times or more
 (2) Interface Connector Attach/Detach 500 times or more

4. Configuration

See Figure 5 for details of the configurations.

4.1. Electrical Circuits

- (1) Drawer Eject Switch
- (2) Optical Pickup Servo Control Circuit
- (3) Feed Motor Drive Circuit
- (4) Laser Diode Control Circuit
- (5) EFM Demodulator and CD-ROM Error Correction Circuit
- (6) IDE/ATAPI Interface Control Circuit
- (7) System Control Circuit
- (8) Analog Audio output

4.2. Optical Pickup

Semiconductor Laser and 3-beam System

4.3. Spindle Motor

Brush- less DC Motor

4.4. Feed Motor

DC Motor with Non-contact Type Velocity sensor

XM-7002B BLOCK DIAGRAM

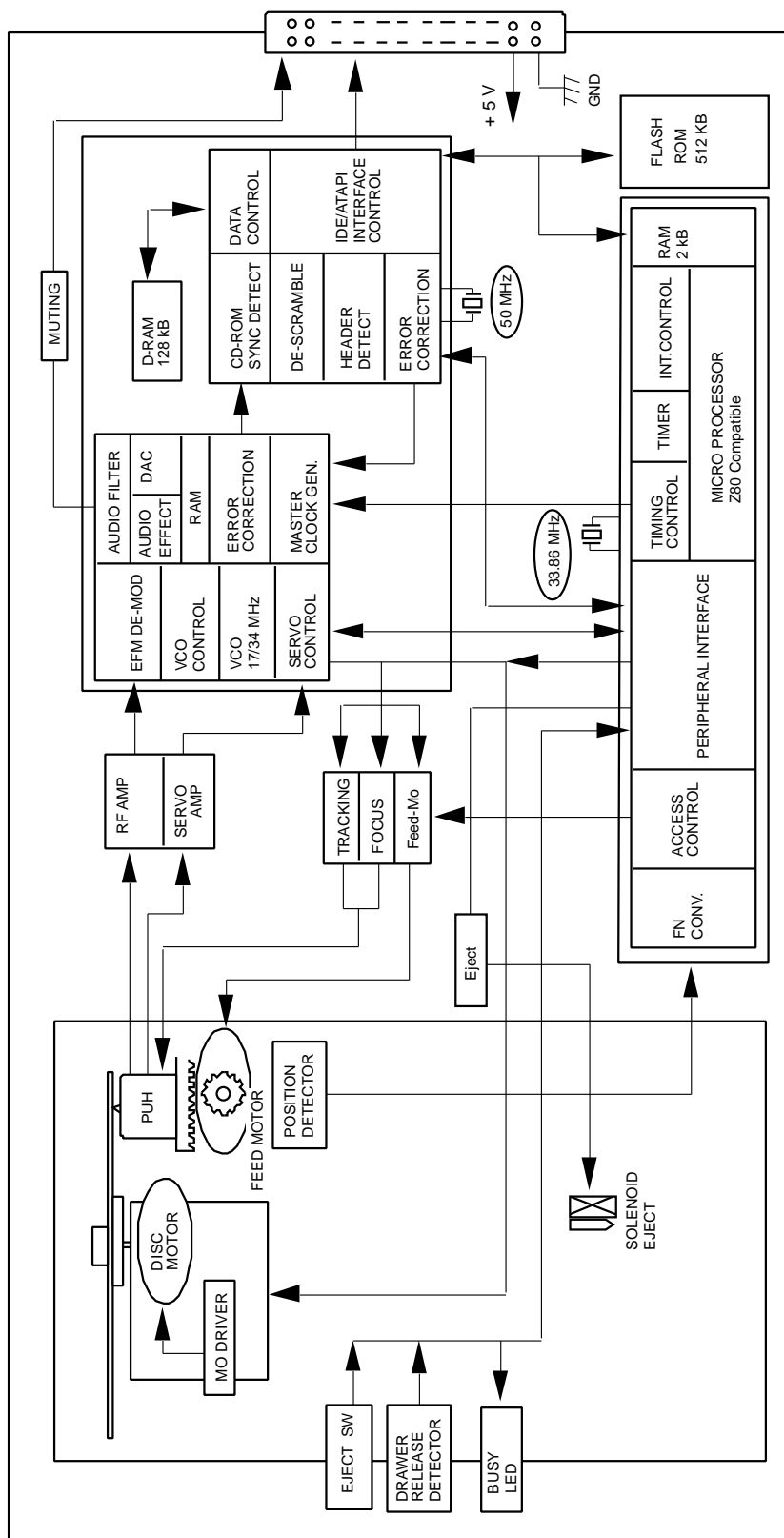

Figure 5 Basic configuration of XM-7002B

5. Functions

5.1. CD-ROM Data Configurations

Figure 6 shows how the data is structured in program units.
 1block=1/75 s

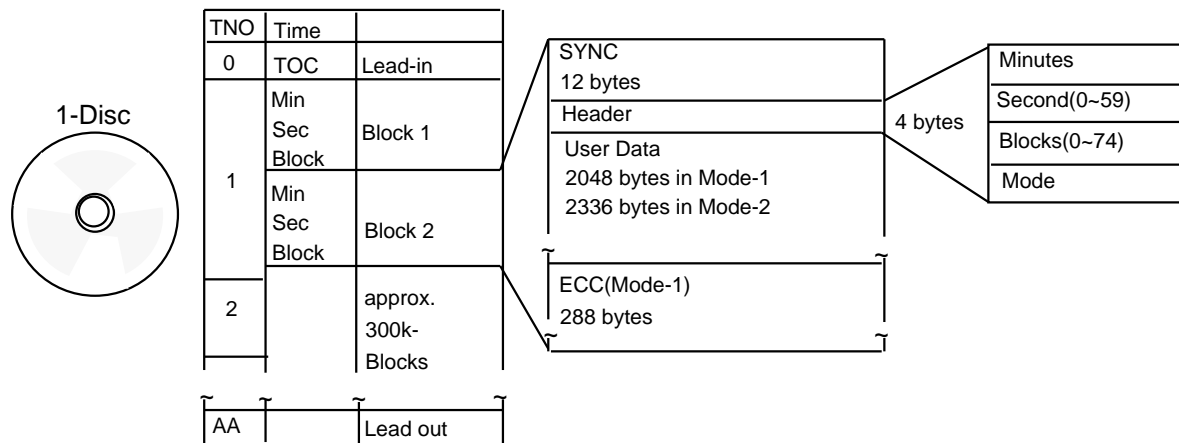

Figure 6 CD-ROM Data Configuration

5.2. Power ON/OFF Timing

Figure 7 shows the initialization.

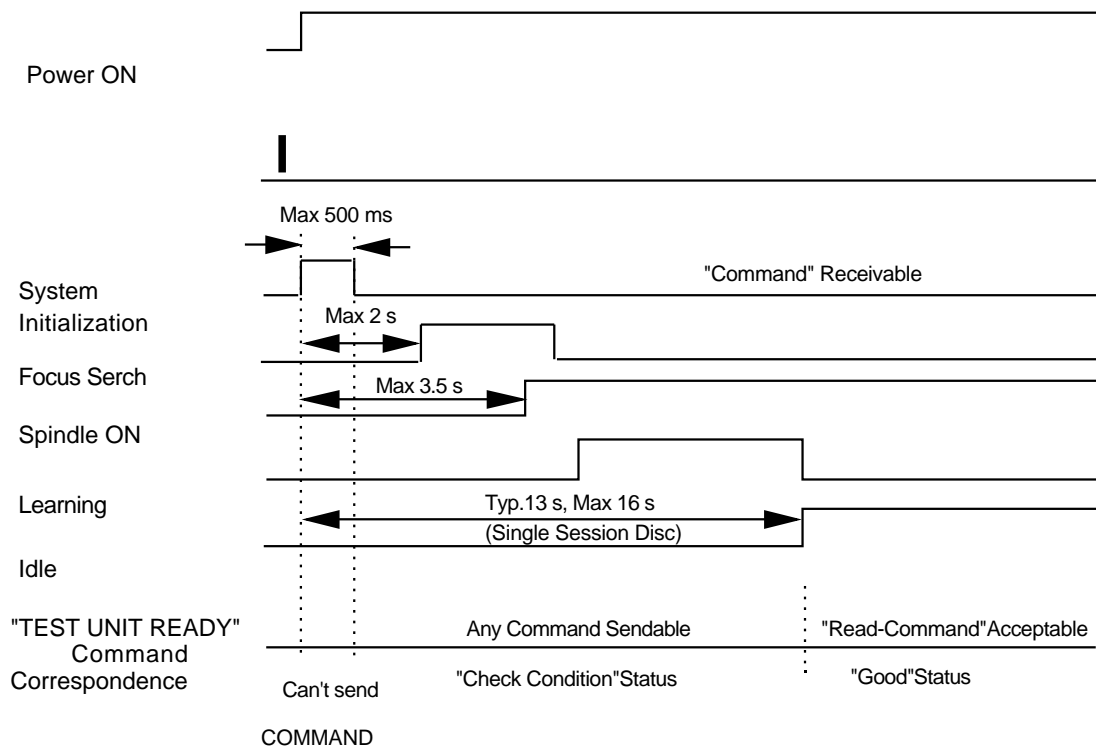

Figure 7 Initialization Sequence

5.3. Standby mode

Figure 8 shows the standby sequence.

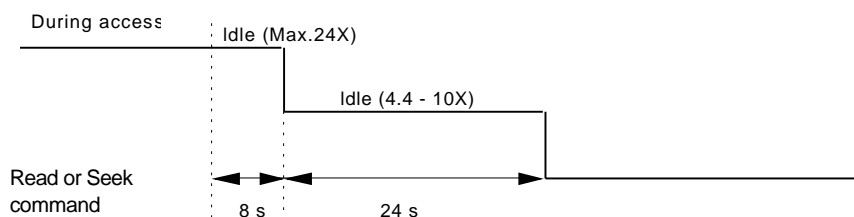

Figure 8 Standby Sequence

Rotational speed move onto 4.4 to 10X mode in 8 seconds of the Read or Seek command. After 24 seconds (default value), it move onto standby mode. (a stop spindle motor)

6. Interface

- (1) The interface is based on ATA-SPEC, ATAPI-SPEC SFF-8020i Revision 2.6, SFF-8028 Revision 1.0 and SFF-8090 version 2.
(Small Form Factor Committee Specification of ATA-Packet Interface for CD-ROMs)
- (2) 48 types of commands are usable including ATA & ATAPI Commands.
- (3) The 128 KByte data buffer handles both high speed and low speed data transmission.
- (4) The largest one block size on playback is 2,448 Bytes.
The data length for each block is changeable by command.
- (5) Please refer to the standard of ATA/ATAPI-4 for details of the interface timing.

6.1. I/O cable

Table 1 shows the cable parameters.

	Min	Max
Cable length		0.46 m
Driver IoL sink current for 5V operation	12 mA	
Driver IoH source current		-400 μ A
Cable capacitive loading		200 pF
Power Supply cablesPIN No.38 - 42(+B),43 - 45(GND)	1.5 A	

Table 1 Cable parameters

6.2.Signal summary

The physical interface consists of single ended TTL compatible receivers and drivers communicating through a 50P-conductor as shown in Figure 9,10 - 13.

6.2.1.Signal Specifications

Figure 9 shows the Signal Specifications

Sig. Name	Type	Receivers/Drivers Characteristics without External pullup Resistor				NOTE	
			Min	Max	Condition		
DD0 -DD15 /DASP /PDIAG		VOH	Voltage Output High	V _{dd} -0.4 V		IOH=1 mA	Bidirectional Rx=infinity Ri=infinity Rs=33 OHM DD0-DD15 Rx=10 kOHM Ri=20 kOHM Rs=0 OHM /PDIAG /DASP Rx=10 kOHM Ri=100 kOHM Rs=0 OHM
		VOL	Voltage Output Low		0.4 V	IOL=12 mA	
		VIH	Input HIGH Voltage	2.0 V		TTL	
		VIL	Input LOW Voltage		0.8 V	TTL	
		ILI	Input leakage Current	-5 µA	-150 µA	Pullup Resistor(Ri)	
		IOL	Driver sink current	12 mA			
		ILO	Output Leakage Current	-30 µA	-150 µA	Pullup Resistor(Ri)	
		CI	Input Capacitance		8 pF		
		CO	Output Capacitance		8 pF		
/IOCS16		VOL	Voltage Output Low		0.4 V	IOL=24 mA	Open Drain Rs=0 OHM Rx=10 kOHM Ri=infinity
		IOL	Driver sink current	24 mA			
		ILO	Output Leakage Current	-30 µA	-150 µA	Pullup Resistor(Ri)	
		CO	Output Capacitance		8 pF		
IORDY		VOH	Voltage Output High	2.4 V		IOH=400 µA	Rs=22 OHM Rx=10 kOHM
		VOL	Voltage Output Low		0.4 V	IOL=24 mA	
		IOL	Driver sink current	24 mA			
		ILO	Output Leakage Current	-10 µA	10 µA		
		CO	Output Capacitance		8 pF		
DMARQ INTRQ		VOH	Voltage Output High	V _{dd} -0.4 V		IOH=400 µA	DMARQ Rs=22 OHM 3 state(Hiz) INTRQ Rs=22 OHM 3 state(Hiz)
		VOL	Voltage Output Low		0.4 V	IOL=12 mA	
		IOL	Driver sink current	12 mA			
		ILO	Output Leakage Current	-10 µA	10 µA		
		CO	Output Capacitance		8 pF		
/DIOW /DIOR DA0 - DA2 /CS1FX /CS3FX		VIH	Input HIGH Voltage	2.0 V		TTL	Ri=100 kOHM, Rx=infinity, Rs=82 OHM /DMACK,/DIOW,/DIOR DA0 - DA2 Ri=100 kOHM, Rx=10 kOHM Rs=82 OHM, /CS1FX,/CS3FX Ri=infinity, Rx=10 kOHM Rs=470 OHM, CSEL
		VIL	Input LOW Voltage		0.8 V	TTL	
		ILI	Input leakage Current	-5 µA	-150 µA	Pullup Resistor(Ri)	
		CI	Input Capacitance		8 pF		
/RESET		VIH	Input HIGH Voltage	2.0 V		TTL	Rx=100 kOHM Rs=1 kOHM
		VIL	Input LOW Voltage		0.8 V	TTL	
		ILI	Input leakage Current	-5 µA	-150 µA	Pullup Resistor(Ri)	
		CI	Input Capacitance		8 pF		

Figure 9 Signal Specifications

6.2.2. Timing of Host Interface (PIO)

Figure 10 shows the Host Interface Timings.

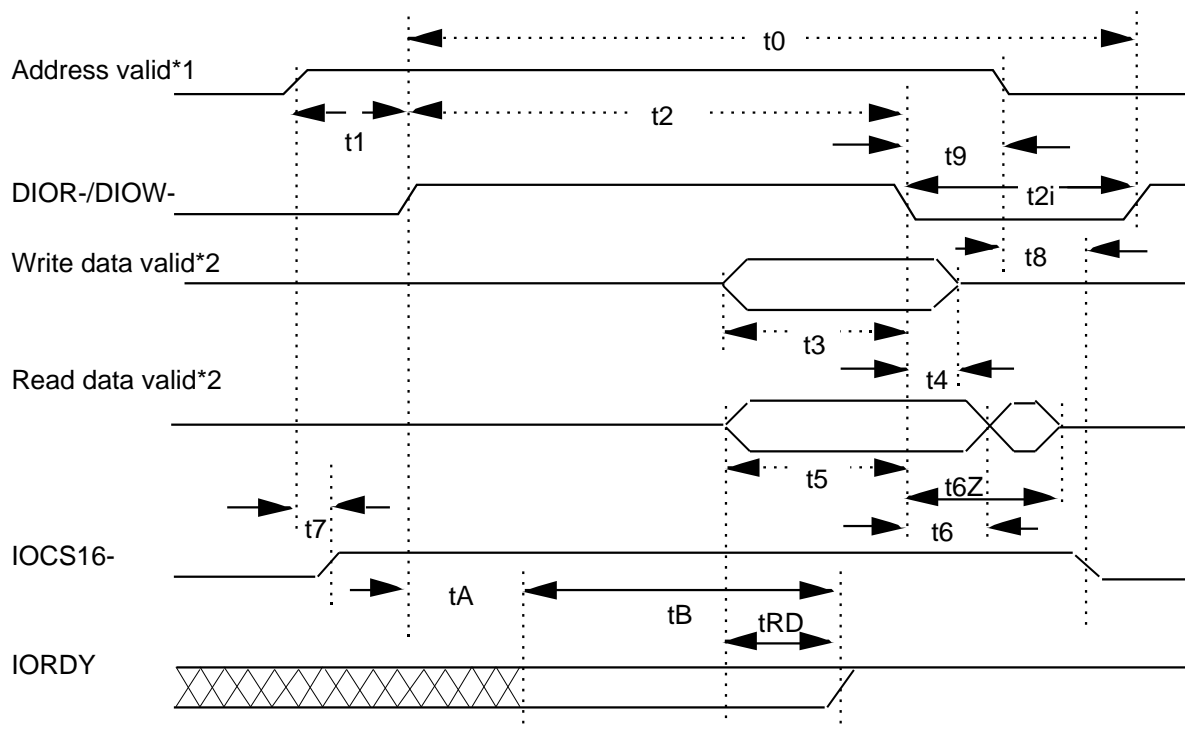

*1: Device Address consists of signals CS0-, CS1-, and DA2-0

*2: Data consists of DD0-15 (16-bit) or DD0-7 (8-bit)

	PIO Mode 4 timing parameters	min(ns)	max(ns)	Min Time (ns)	Max Time (ns)
t0	Cycle time			120	
t1	Address valid to DIOR-/DIOW-setup			25	
t2	DIOR-/DIOW- pulse wide			70	
t2i	DIOR-/DIOW- recovery time			25	
t3	DIOW- data setup			20	
t4	DIOW- data hold			10	
t5	DIOR- data setup			20	
t6	DIOR- data hold			5	
t6Z	DIOR- data tristate				30
t7	Addr valid to IOCS16- assertion				30
t8	Addr valid to IOCS16- negation				30
t9	DIOR-/DIOW- to address valid hold			10	
tRD	Read Data Valid to IORDY active			0	
tA	IORDY setup time				35
tB	IORDY pulse wide				1250

Figure 10 Host Interface Timin

6.2.3. Timing of Host Interface (DMA Multi)

Figure 11 shows the Host Interface DMA multi word Timings

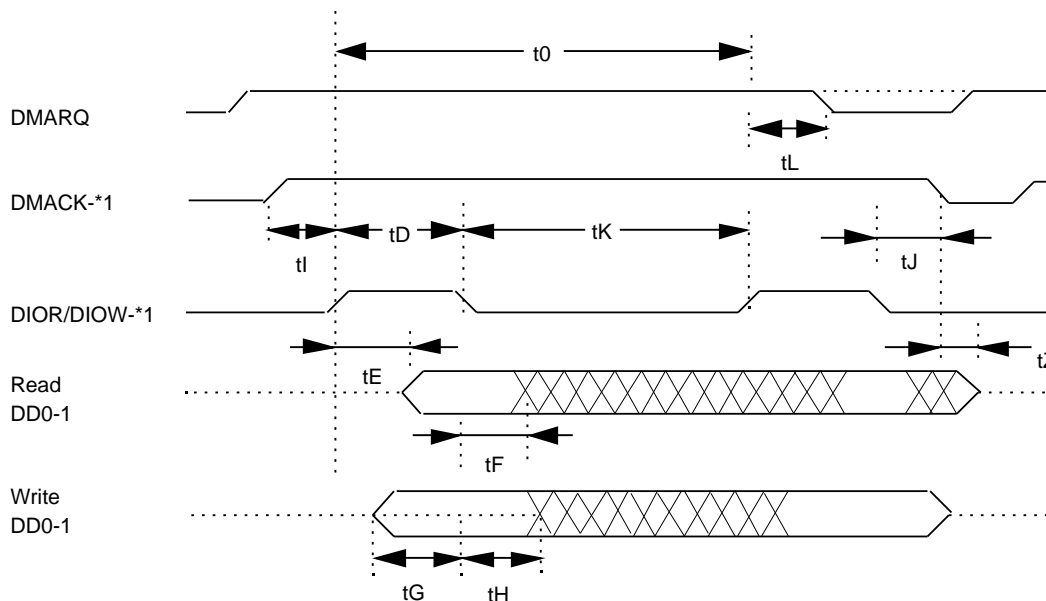

*1: In all timing diagrams, the low line indicator negated, and the upper line indicators asserted.

	Multi word DMA Mode 2 timing parameters	min (ns)	max (ns)	Min time (ns)	Max time (ns)
t0	Cycle time			120	
tC	DMACK to DMREQ delay				---
tD	DIOR-/DIOW- 16-bit			70	
tE	DIOR- data access				50
tF	DIOR- data hold			5	
tZ	DMACK- to tristate				25
tG	DIOR/DIOW- data setup			20	
tH	DIOW- data hold			10	
tI	DMACK to DIOR-/DIOW- setup			0	
tJ	DIOR-/DIOW- to DMACK hold			5	
tKr	DIOR- negated pulse width			25	
tKw	DIOW- negated pulse width			25	
tLr	DIOR- to DMREQ delay				35
tLw	DIOR- to DMREQ delay				35

Figure 11 Host Interface Timing (DMA Multi)

6.2.4. Timing of Host Interface (Ultra DMA)

Figure 12 shows the Host Interface Ultra DMA word Timings

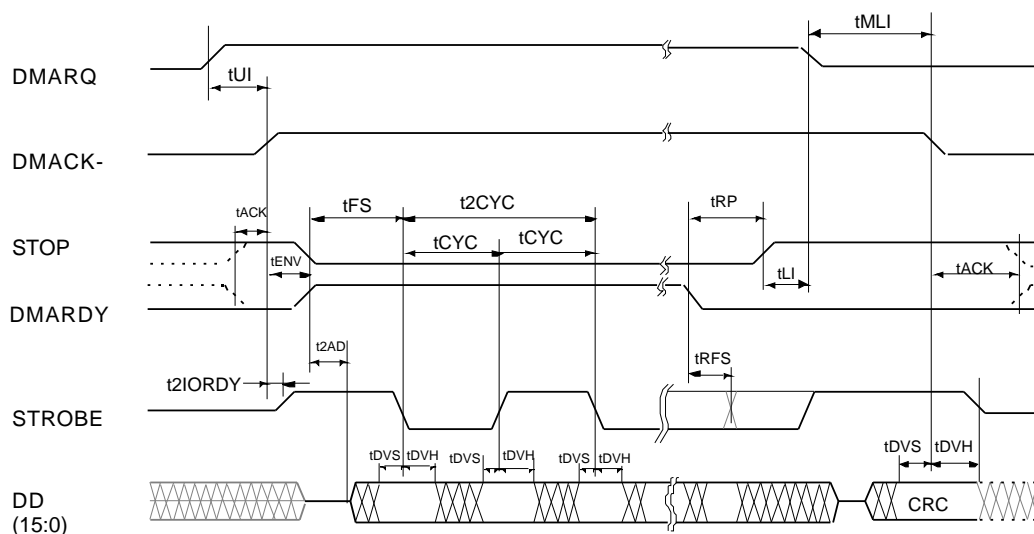

	Ultra DMA Mode 2 timing parameters	min (ns)	max (ns)	Min time (ns)	Max time (ns)
t2CYC	Typical Sustained Average Cycle time			120	
tCYC	Cycle time			55	
tDVS	Data Setup time			34	
tDVH	Data Hold time			6	
tUI	Unlimited Interlock time			0	
tACK	Setup and Hold Time for DMACK-			20	
tENV	Envelope time			20	70
t2AD	Minimum Delay time for Driver			0	
t2IORODY	Minimum time for DMACK-			20	
tFS	First STROBE time			0	170
tRFS	Ready-to-Final STROBE time				50
tRP	Ready-to-Pause time			100	
tLI	Limited Interlock time			0	150
tMLI	Interlock with minimum			20	

Figure 12 Host Interface Timing (Ultra DMA)

6.3. Connector

Figure 13 shows the connector and Figure 14 shows the interface pin assignments

Use Japan Aviation Electronics Industry Limited KX15-50KLD L or equivalent.

Conformable connector is Japan Aviation Electronics Industry Limited KX14-50K*D or equivalent.

(Note: * is No.2,8,5, 8, 11. The recommendation is No.5)

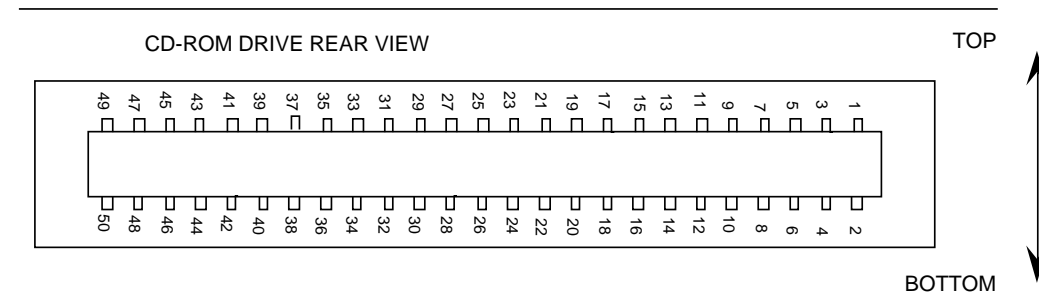

Figure 13 Connector pin assignments

Signal name	I/O	Connector contact		I/O	Signal name
Audio L-CH	O	1	2	O	Audio R-CH
Audio Ground		3	4		Digital Ground
/RESET	I	5	6	I/O	DD8
DD7	I/O	7	8	I/O	DD9
DD6	I/O	9	10	I/O	DD10
DD5	I/O	11	12	I/O	DD11
DD4	I/O	13	14	I/O	DD12
DD3	I/O	15	16	I/O	DD13
DD2	I/O	17	18	I/O	DD14
DD1	I/O	19	20	I/O	DD15
DD0	I/O	21	22	O	DMARQ
Digital Ground		23	24	I	/DIOR: /HDMARDY: HSTROBE
/DIOW: STOP	I	25	26		Digital Ground
IORDY: /DDMARDY: DSTROBE	O	27	28	I	/DMACK
INTRQ	O	29	30	O	/IOCS16
DA1	I	31	32	I/O	/PDIAG
DA0	I	33	34	I	DA2
/CS1FX	I	35	36	I	/CS3FX
/DASP	I/O	37	38	I	+5 V(MOTOR)
+5 V(MOTOR)	I	39	40	I	+5 V(MOTOR)
+5 V(LOGIC)	I	41	42	I	+5 V(LOGIC)
Ground		43	44		Ground
Ground		45	46		Ground
Device Config.(CSEL)	I	47	48		Ground
N.C (OPEN)		49	50	I	Vender unique *

A slash character(/) at the beginning of a signal name indicates it is asserted at the low level (active low).

* Do not connect anything with vender unique (50P).

Figure 14 Signal assignments

6.4.Support Command List

6.4.1. ATAPI Packet Command for CD-ROM Devices

Command	OP Code	XM-7002B
AUDIO SCAN	BAh	YES
GET EVENT STATUS NOTIFICATION	4Ah	YES
GET CONFIGRATION COMMAND	46h	YES
GET PERFORMANCE COMMAND	ACh	YES
INQUIRY	12h	YES
MECHANISM STATUS	BDh	YES
MODE SELECT(10)	55h	YES
MODE SENSE(10)	5Ah	YES
PAUSE/RESUME	4Bh	YES
PLAY AUDIO(10)	45h	YES
PLAY AUDIO(12)	A5h	YES
PLAY AUDIO MSF	47h	YES
PLAY TRACK RELATIVE(10)	49h	YES
PLAY TRACK RELATIVE(12)	A9h	YES
PREVENT/ALLOW MEDIUM REMOVAL	1Eh	YES
READ(10)	28h	YES
READ(12)	A8h	YES
READ C/DVD CAPACITY	25h	YES
READ CD	BEh	YES
READ CD MSF	B9h	YES
READ DISC INFORMATION COMMAND	51h	YES
READ FORMATTED CAPACITIES COMMAND	23h	YES
READ HEADER	44h	YES
READ SUB-CHANNEL	42h	YES
READ TOC	43h	YES
READ TRACK/RZONE INFORMATION COMMAND	52h	YES
REQUEST SENSE	03h	YES
REZERO UNIT	01h	YES
SEEK	2BH	YES
SET CD-ROM SPEED	BBh	YES
SET READ AHEAD COMMAND	A7h	YES
SET STREAMING COMMAND	B6h	YES
SEND EVENT COMMAND	A2h	YES
STOP PLAY/SCAN	4Eh	YES
START/STOP UNIT	1Bh	YES
TEST UNIT READY	00h	YES

6.4.2. ATA Command for ATAPI CD-ROM Devices

Command	OP Code	XM-7002B
ATAPI SOFT RESET	08h	YES
CHECK POWER MODE	E5h	YES
EXECUTE DRIVE DIAGNOSTICS	90h	YES
IDLE IMMEDIATE	E1h	YES
IDLE	E3h	YES
NOP	00h	YES
ATAPI PACKET COMMAND	A0h	YES
ATAPI IDENTIFY DEVICE	A1h	YES
SET FEATURES	EFh	YES
SLEEP	E6h	YES
STANDBY IMMEDIATE	E0h	YES
STANDBY	E2h	YES

7. Power Requirements

7.1. Source Voltage	+5 V +/- 5 % (Operating)
7.1.1 Spike	100 mV (p-p) Max
7.1.2 Ripple	100 mV (p-p) Max
7.2. Current Drain (Typ. Value)	
7.2.1. Sleep(Minimum Current Mode)	0.025 A
7.2.2. Standby(Laser off,motor off)	0.03 A
7.2.3. Idle(Laser on,motor on)	0.32 A
Start Position	
7.2.4. Continuous Read(Audio/Data)	0.62 A (Max.24X) / 0.35 A (Max.10X)
Start Position	
7.2.5. Average(20% Duty Random Access)	0.64 A (Max.24X) / 0.34 A (Max.10X)
7.2.6. Maximum(100% Duty Random Access)	0.76 A (Max.24X) / 0.44 A (Max.10X)
7.2.7. Peak in executing Access	1.4 A
(With out Spike Current*)	
7.2.8. Peak Current	1.5 A
(With out Spike Current)*	
*Spike:Less than 1ms width current	

8. Audio

8.1. Line Output ----- in case of the attenuator is set at 0 dB by the command -----

(1) Output Level	0.775 V (rms Typ)+/- 3 dB
(2) Type	Unbalanced
(3) Output Impedance	2.2 kOHM
(4) Load Impedance	47 kOHM
(5) Frequency Response	20 Hz to 20 kHz +/- 3.0 dB.(at 47 kOHM Load)
(6) Distortion	0.03 % Max. (at 1 kHz weighted 20 kHz LPF)
(7) Signal to Noise Ratio	78 dB Typ (IEC 179 A-weighted)

8.1.1. Audio Cable Unbalanced and shielded

(1) Capacitance	Less than 1000 pF
(2) Length	Max. 3 m

8.1.2. Connector

Figure 13, 14 shows the connector and Audio signal pin assignment.

8.2. Audio Modes

(1) 16 Modes including 'Stereo', 'Lch Mono', 'Rch Mono' and 'Mute' are selectable by command.
Default mode is 'Stereo'.

The audio output is automatically muted in the state other than the time of audio track playback.

(2) 16 Steps of attenuation level for the Audio Output is selectable by command.
Default level is 0 dB.

9. Device Configuration

9.1 Master mode setting

Open the PIN 47 of I/O connectors.

9.2 Slave mode setting

Short-circuit the PIN 47 and PIN 48 of I/O connectors.

*Master mode can be oppositely to Slave mode according to the specification. (CSEL mode)

10. Busy Indicator

The LED at Front Bezel (Busy Indicator) indicates the drive status.

Color: UMBER

(1) After Drawer is closed, Busy Indicator start blinking at 0.8 s intervals, and then -----

(1-1) Turns off when the drive in the 'Idle' status.

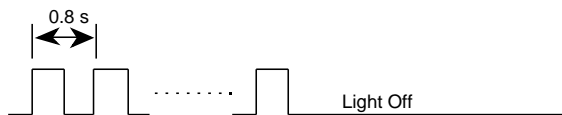

Figure 15 Idle

(1-2) Continuously off when no disc is mounted.

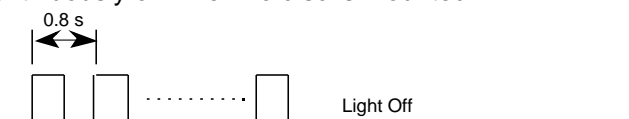

Figure 16 No disc

(1-3) Continuously on when media has problem

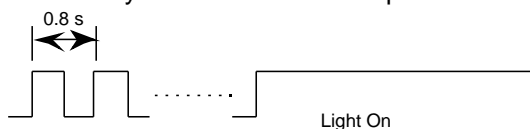

Figure 17 Media Problem

(2) When playing an audio track, Busy Indicator is blinking at 1.6 s intervals.

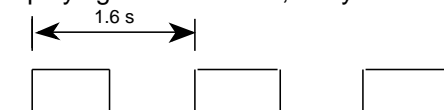

Figure 18 CD-Audio playback

(3) When performing 'Data Access' and during 'Data Transfer' Busy Indicator keeps turn On.

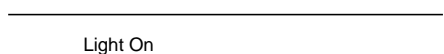

Figure 19 Data Access and Data Transfer

(4) When pushing Eject button, Busy indicator is blinking at 0.4 s intervals.

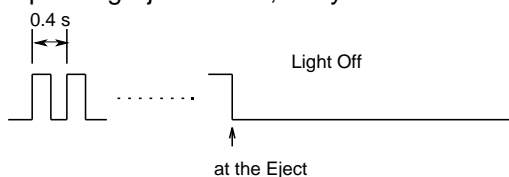

Figure 20 Eject

11.Maintenance

11.1. Disc

Try to avoid touching the read area (underside) of the disc as dirt and smears will degrade the disc accessing speed.

If the disc is dirty, wipe it with a soft cloth.

11.2. Optical Pickup

A dirty Optical Pickup will also degrade the access time.

When the Pickup is dirty, gently wipe the objective lens of the Pickup.

12.Emergency Eject

Execute following procedure only in the case of emergency (drawer will not eject although pressing Eject button).

(1) Turn the CD-ROM drive supplying power off, and then keep the this condition for 1 minute.

(2) Insert solid bar (like paper clip) into Emergency eject hole and push as shown in Figure 21.

Then Tray will be ejected.

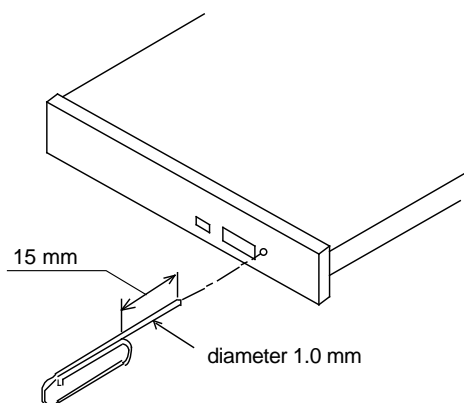

Figurer 21 Insert the bar

13.Safety standards/Agency Approvals

- | | |
|------------|--|
| (1) Safety | EN60950
UL 1950
CAN/CSA-22.2 No.950 |
| (2) Laser | FDA CFR21, EN60825 |
| (3) EMI | FCC 15J - B |
| (4) CE | EN50081-1 :1992 [Residential, commercial & light industry]
EN55022+A2 :1994+1997 [Class B]
EN55024 :1997 [Information tecnology equipment-Immunity characteristics-Limits and methods of measurement]
IEC61000-4-2+A1:1995+1998 [CD:4 kV, ID: 4 kV, AD:8 kV]
IEC61000-4-3 :1996 [3 V/m, 80-1000 MHz, 1 kHz 80 % AM]
IEC61000-4-4 : 1995 [AC-line: 1 kV, f: 5 kHz, Polarity:+/-]
IEC61000-4-5 : 1995 [AC-line: 1 kV/2 kV, Polarity:+/-]
IEC61000-4-6 : 1996 [3 V, 0.15-80 MHz, 1 kHz 80 % AM]
IEC61000-4-8 : 1993 [1 A/m, 50 Hz] |
| (5) EMI | KOREAN EMI Regulation (RRL) |

14. Electrostatic Discharge

- | | |
|--------------------------------------|---------------|
| (1) Operating (Air discharge) | 15 kV or less |
| (2) Damage including (Air discharge) | 20 kV or more |

15. Accessories

Non

16. Packaging

- a. 25 units in a Bulk Pack
36 Bulk Packs on one Pallet
*Transportation must be executed with each palette.

- b. 20 units in a Bulk Pack
24 Bulk Packs on one Pallet

Packing Specifications

:for 25 Packaged Model: IB-CD2-A90012

:for 20 Packaged Model: IB-CD2-A90013

17. CE Declaration of conformity

Please refer to attached Annex 1.

TOSHIBA

TOSHIBA EUROPE GMBH

EU-Declaration of Conformity

Product: CD-ROM Drive

Manufacturer(s): Toshiba Corporation
 1-1, Shibaura 1-chome, Minato-ku, Tokyo 105-8001 Japan

See page 2 for other locations

Model: XM-7002B

Options: None

Toshiba declares that the above mentioned product(s) with or without the listed options comply to the EU-Directives and standards as listed on page 2.

Last two digits of the year in which the CE mark affixed : 98

Responsible for CE-marking: Toshiba Europe GmbH

Signed by: Mr. H.Nonaka, President of Toshiba Europe GmbH

Place: D-41460 Neuss

Date: May 07, 1999

Signature: _____

This declaration certifies compliance with the listed directives, but does not constitute an assurance of characteristics.
 The safety information in the supplied product documentation must be observed.

Document No.:	YEA-T023	Page:	1 of 2
[History if issue]	Issued : May 06, 1999		
	Revision A :	Ref.:	
	Revision B :	Ref.:	
	Revision C :	Ref.:	
	Revision D :	Ref.:	

TOSHIBA EUROPE GMBH
 HAMMFELODAMMB.D-41460NEUSS
 POSTFCH 101482. D-41414 NEUSS
 TELEFON: (02131) 158-01
 TELFAX : (02131) 158-341

GESCHAFTSUHRER
 HISATSUGU NONAKA
 HRB 3479 AMTSGERICHT NESS

Annex 1

EU-Declaration of Conformity

ED-Directive	Related Standard	Issue	Level/Test condition	
899/336/EEC (EMC Directive)	EMC-emission:	1992	Residential, commercial & light industry Class B	
	EMC-immunity	EN50081-1	Information technology equipment-Immunity characteristics-Limits and methods measurement	
		EN55022+A2		
		EN5524	1994+1997	
		IEN61000-4-2+A1	1995+1998	
		IEN61000-4-3	1996	
		IEN61000-4-4	1995	
		IEN61000-4-5	1995	
		IEN61000-4-6	1996	
		IEN61000-4-8	1993	

Product/Options	Model	Related EU-Directive 89/336/EEC
CD-ROM Drive	XM-7002B	X
Manufacturer(s) Location	Address	
Toshiba Multi Media Devices Co, L	19 Minase, Fukiata Goshogawara-shi, Aomori 037-0003 Japan	
Toshiba Misawa Media Devices Co, Lt	3-31-2779, Minami-cho, Misawa-shi, Aomori-ken 033-0036 Japan	
EMS Corp.	4-5 Shoubu, Ubayachi Goshogawara-shi, Aomori 037-0015 Japan	
Hokuto Communication Industrial Co., Ltd.	207 Aza Koamon, Rokugo, Rokugo-machi, Senboku-gun, Akita 019-1404 Japan	
Yuzawa Denshi Kogyo Co., Ltd.	257 Nakano Yuzawa-shi, Akita 012-0041 Japan	
EMS Kizukuri Corp.	1-2 Aza-Miyazaki, Kizukuri-machi, Nishi-Tugaru-gun Aomori 038-3157 Japan	
Emusu Itayanagi Co., Ltd.	13-10, Matsumoto, Tsuji, Itayanagi, Kita-Tyugaru-gun, Aomori, 038-3645 Japan	
EMS Fukaura Co., Ltd	24-1 Aza Azumazawa, Ohaza Fukaura, Fukaura-machi, Nishi-Tsugaru-gun, Aomori, 037-0401 Japan	
Tsugaru Technica Co., Ltd.	81-87 Iwai, Aiuchi, Shiura-machi, Kitatsugaru-gun, Aomori, 037-0401 Japan	
Toshiba Information Equipment (Philippines) Inc	103 East Main Avenue Extension, Special Export Processing Zone, Laguna Technopark, Binan, Laguna Philippines	
Integrated Microelectronic Inc.	North Science Avenue Laguna Techno Park Inc. Binan, Laguna Philippines	

Document No.: YEA-T023 **Revision:** -----
Page: 2 of 2 -----

Deviation List

Page	Item	Rev# 0.8	Rev# 1.0
2	2. Features	(21) Low Power...(Approx. 3.5 W) (target) (25) Data Transfer..... DMA Single Word Transfer.....	(21) Low Power...(Typ. 3.2 W) (20% Dirty Random Access) None
3	3.1. Performance (4) Transfer Rate Burst	8.33 MByte/s (DMA single word Mode2)	None
4	(5) Access Time Average Ranom Access.....	(5) Access Time.....(Target) 95 ms (Max.24X) (target)	(5) Access Time 95 ms (Max.24X)
6	3.3. Installation Conditions Mounting:Vertical	15°	30° / 15°
7	Figure 1		
12	5.2. Power ON/OFF Timing	5.2. Power ON/OFF Timing (TENTATIVE)	5.2. Power ON/OFF Timing
13	5.3. Standby mode	5.3. Standby mode (TENTATIVE)	5.3. Standby mode
14	6.2.1. Signal Specifications	6.2.1. Signal Specifications (TENTATIVE)	6.2.1. Signal Specifications
14	6.2.3. Timing Host Interface (DMA Single)	6.2.3. Timing Host Interface (DMA Single)	None
18	6.3. Connector	(Note:* is No.5,8, 11.....)	(Note:* is No.2,8,5,8, 11.....)
21	7.2. Current Drain 7.2.1. Sleep 7.2.2 Standby 7.2.3. Idle	7.2. Current Drain.... (TENTATIVE) 0.023 A 0.026 A 0.32 A (Max.24X)]	7.2. Current Drain (Typ. Value) 0.025 A 0.03 A 0.32 A
24	13. Safety standard.....	13. Safety standard..... (TENTATIVE)	13. Safety standard.....
26	16. Packing	Standard packimng Spcifications : 25 unitin.....: TBD : 20 unitin.....: TBD	Packing Specifications :for 25 Packaged Model: IB-CD2-A90012 :for 20 Packaged Model: IB-CD2-A90013
27	Annex 1	Tentative	Non-Tentative
28	EU-Declaration of Conformity	Tentative	Non-Tentative

Free Manuals Download Website

<http://myh66.com>

<http://usermanuals.us>

<http://www.somanuals.com>

<http://www.4manuals.cc>

<http://www.manual-lib.com>

<http://www.404manual.com>

<http://www.luxmanual.com>

<http://aubethermostatmanual.com>

Golf course search by state

<http://golfingnear.com>

Email search by domain

<http://emailbydomain.com>

Auto manuals search

<http://auto.somanuals.com>

TV manuals search

<http://tv.somanuals.com>