

TECHNICAL TRAINING PROGRAM

- PRE-STUDY MANUAL -



e-STUDIO900/1050

Toshiba America Business Solutions

It is the reader's responsibility when discussing the information contained within this document to maintain a level of confidentiality that's in the best interest of Toshiba Corporation and its member companies.

***NO PART OF THIS DOCUMENT MAY BE REPRODUCED IN ANY
FASHION AND DISTRIBUTED WITHOUT THE PRIOR
PERMISSION OF TOSHIBA CORPORATION.***

All product names, domain names or product illustrations, including desktop images, used in this document are trademarks, registered trademarks or the property of their respective companies. They are used throughout this book in an informational or editorial fashion only and for the benefit of such companies. No such use, or the use of any trade name, or web site is intended to convey endorsement or other affiliation with Toshiba products.

© 2003 TABS Corporation. All rights reserved.

WARNING

The Pre-Training Manual contains information regarding service techniques, procedures, processes and spare parts of office equipment distributed by Toshiba Corporation. Users of this manual should be either service trained or certified by successfully completing a Toshiba Technical Training Program. Untrained and uncertified users utilizing information contained in this pre-training manual to repair or modify Toshiba equipment risk personal injury, damage to property or loss of warranty protection.

Toshiba Corporation

LEGEND

PRODUCT CODE	COMPANY			
	Toshiba			
B070	900			
B071	1050			
LCT B511	MP-4501L(RT46 Large Capacity Tray)			
Finisher B478	MJ-1026(SR840 3,000-SHEET FINISHER)			
Cover Int. B470	MJ-7002(Cover Interposer Tray Type 1075)			
Bypass Tray B512	MY-1024(Multi Bypass Tray Type 2105)			

INTRODUCTION

The Pre-Training Manual for the 900/1050 has been designed to give the Service Technician an overview of these products prior to attending the training program. This manual starts with the basic fundamentals utilized in the machine and reviews the entire copy process and accessories.

It is the aim of the Service Education and Development Division to give the Service Technician as much hands-on experience as possible while attending training. In order to accomplish this, a relatively small amount of time will be spent on the basic fundamentals in class. For these reasons a thorough understanding of this document is necessary.

At the end of this Pre-Training Manual it is necessary to complete a Pre-Training Test found on the Toshiba FYI Website.

This test is provided to ensure that the Service Technician has an understanding of the electronics, the copy process and the machine operations. When this pre training been completed and passed the technician is approved for the 5-day classroom course.

Should you have any questions, please contact the Service Training Division.

FLOWCHART FOR PRE-TRAINING MANUAL

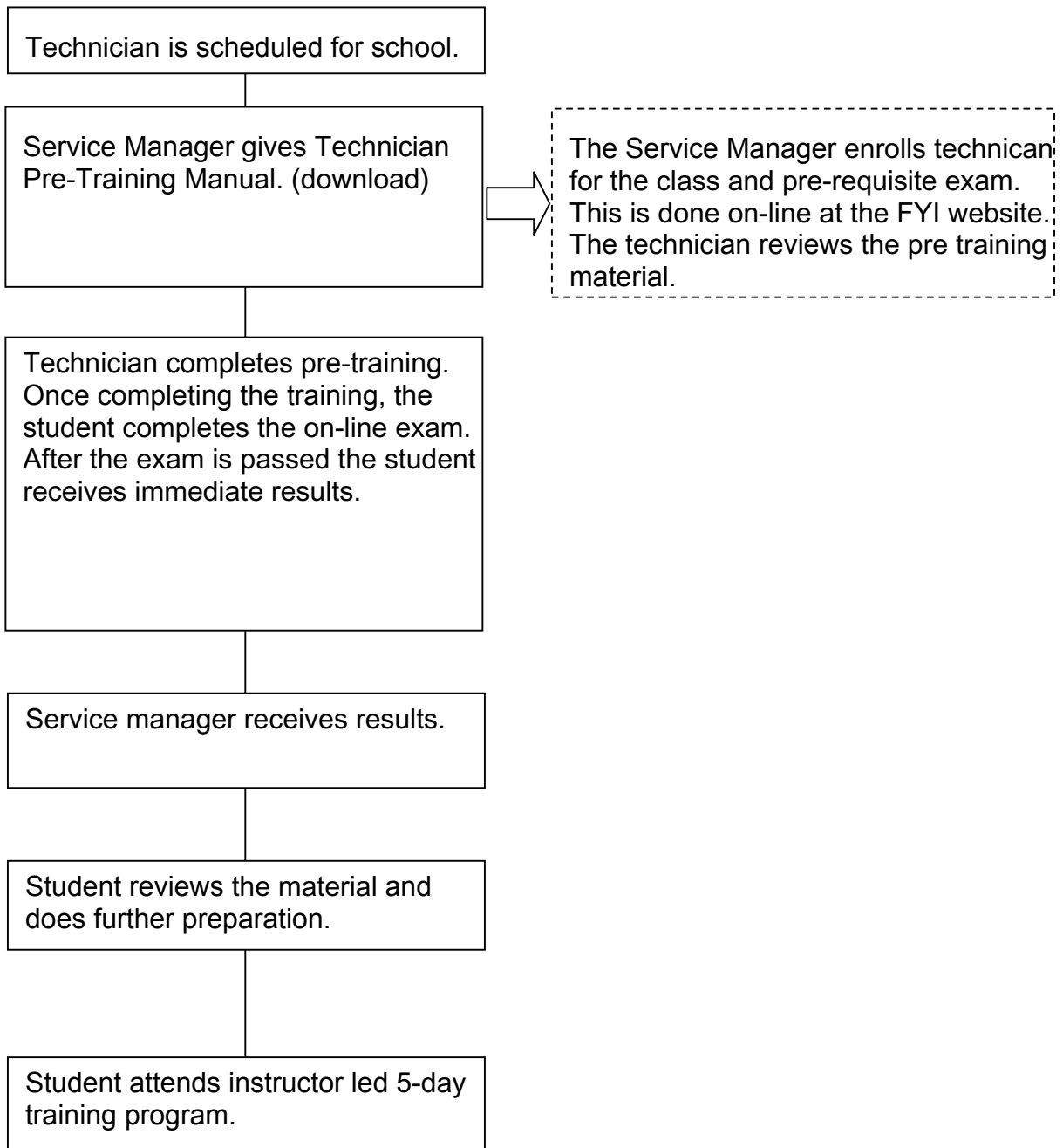

CONTENTS

SECTION 1
OVERALL INFORMATION

SECTION 2
DETAILED DESCRIPTIONS

SECTION 3
SERVICE TABLES

SECTION 4
INSTALLATION

SECTION 5
LARGE CAPACITY TRAY

SECTION 6
SR860 BOOKLET FINISHER
with PUNCH UNIT

SECTION 7
SR840 3,000-SHEET FINISHER
with PUNCH UNIT

SECTION 8
COVER INTERPOSER TRAY TYPE 1075

SECTION 9
MULTI BYPASS TRAY TYPE 2105

IMPORTANT SAFETY NOTICES

PREVENTION OF PHYSICAL INJURY

1. Before disassembling or assembling parts of the copier and peripherals, make sure that the copier power cord is unplugged.
2. The wall outlet should be near the copier and easily accessible.
3. Note that some components of the copier and the paper tray unit are supplied with electrical voltage even if the main power switch is turned off.
4. If any adjustment or operation check has to be made with exterior covers off or open while the main switch is turned on, keep hands away from electrified or mechanically driven components.
5. If the Start key is pressed before the copier completes the warm-up period (the Start key starts blinking red and green alternatively), keep hands away from the mechanical and the electrical components as the copier starts making copies as soon as the warm-up period is completed.
6. The inside and the metal parts of the fusing unit become extremely hot while the copier is operating. Be careful to avoid touching those components with your bare hands.

HEALTH SAFETY CONDITIONS

1. Never operate the copier without the ozone filters installed.
2. Always replace the ozone filters with the specified ones at the specified intervals.
3. Toner and developer are non-toxic, but if you get either of them in your eyes by accident, it may cause temporary eye discomfort. Try to remove with eye drops or flush with cold water as first aid. If unsuccessful, get medical attention.

OBSERVANCE OF ELECTRICAL SAFETY STANDARDS

1. The copier and its peripherals must be installed and maintained by a customer service representative who has completed the training course on those models.
2. The NVRAM on the controller board has a lithium battery which can explode if replaced incorrectly. Replace the NVRAM only with an identical type. However, the manufacturer recommends replacing the entire NVRAM, not just the battery. Never recharge or incinerate a used NVRAM battery. Dispose of a used NVRAM or NVRAM battery in accordance with local regulations.
3. The danger of explosion exists if the battery on the controller board is incorrectly replaced. Replace the battery only with the equivalent type recommended by the manufacturer. Discard the used controller board battery in accordance with the manufacturer's instructions and local regulations.

SAFETY AND ECOLOGICAL NOTES FOR DISPOSAL

1. Do not incinerate toner bottles or used toner. Toner dust may ignite suddenly when exposed to an open flame.
2. Dispose of used toner, developer, and organic photoconductors in accordance with local regulations. (These are non-toxic supplies.)
3. Dispose of replaced parts in accordance with local regulations.
4. When keeping used lithium batteries in order to dispose of them later, do not put more than 100 batteries per sealed box. Storing larger numbers or not sealing them apart may lead to chemical reactions and heat build-up.

LASER SAFETY

The Center for Devices and Radiological Health (CDRH) prohibits the repair of laser-based optical units in the field. The optical housing unit can only be repaired in a factory or at a location with the requisite equipment. The laser subsystem is replaceable in the field by a qualified Customer Engineer. The laser chassis is not repairable in the field. Customer engineers are therefore directed to return all chassis and laser subsystems to the factory or service depot when replacement of the optical subsystem is required.

WARNING

Use of controls, or adjustment, or performance of procedures other than those specified in this manual may result in hazardous radiation exposure.

WARNING





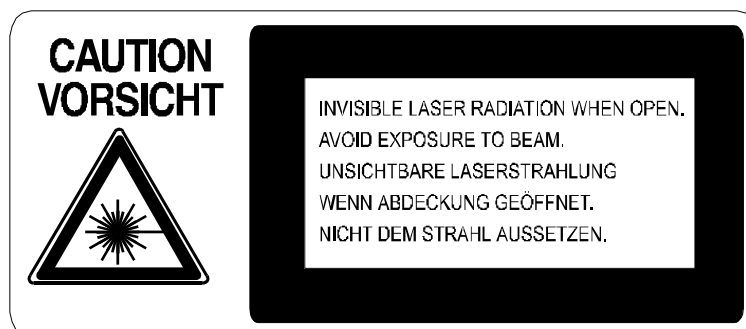

WARNING: Turn off the main switch before attempting any of the procedures in the Laser Unit section. Laser beams can seriously damage your eyes.

CAUTION MARKING:



CONVENTIONS IN THIS MANUAL

This manual uses several symbols.

Symbol	What it means
	Refer to section number
	See Core Tech Manual for details
	Screw
	Connector
	E-ring
	Clip ring
NA	North America
EUR/A	Europe/Asia

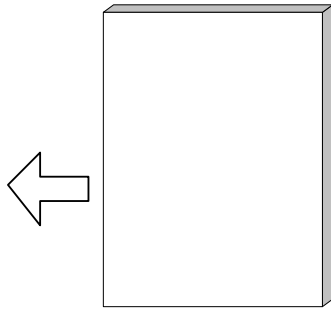

LEF (Long Edge Feed)

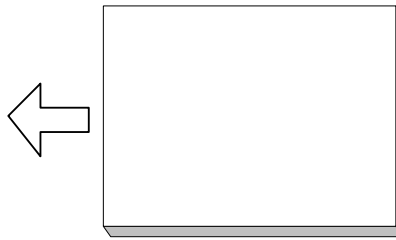

SEF (Short Edge Feed)

SECTION 1

OVERALL INFORMATION

1. OVERALL MACHINE INFORMATION

1.1 SPECIFICATIONS

1.1.1 COPIER ENGINE

Configuration: Console
 Copy Process: Dry electrostatic transfer system
 Originals: Sheet/Book/Object
 Original Size: Max.: A3/11" x 17"
 Min.: A5, 5 1/2" x 8 1/2" (with ADF)
 Original Alignment: Rear left corner (for platen mode, ADF mode)
 Paper Weight: Tray 1~3: 52 to 163 g/m²
 Tray 6 (LCT): Bond: 16 to 40 lb.
 Cover: 50 to 60 lb.
 Index: 90 lb.
 Tray 4~5 (LCT): 52 to 216 g/m²
 Tray 7 (Bypass): Bond: 16 to 40 lb.
 Cover: 50 to 60 lb.
 Index: 90 to 110 lb.
 Duplex Tray (Possible Weight): 64 to 163 g/m²
 Bond: 20 to 40 lb.
 Cover: 50 to 60 lb.
 Index: 90 lb.
 Paper Size: Tray 1 (Tandem): 8 1/2" x 11" LEF, A4 LEF
 Tray 2, Tray 3: 5 1/2" x 8 1/2" to 11" x 17", 12" x 18"
 A5 to A3
 Duplex Tray (Possible Sizes): A5 to A3, 5 1/2" x 8 1/2" to 11" x 17",
 12" x 18"
 Reproduction Ratios: 7 reduction and 5 enlargement

	Metric Version	Inch Version
Enlargement	400%	400%
	200%	200%
	141%	155%
	122%	129%
	115%	121%
Full Size	100%	100%
Reduction	93%	93%
	82%	85%
	75%	78%
	71%	73%
	65%	65%
	50%	50%
	25%	25%

Zoom: 25 ~ 400% (allows manual adjustment in 1% steps vertically, horizontally)

Copy Speed:	900	90 ppm	Copying with image stored in memory with A4/LT LEF feeding from the same tray.
	1050	105 ppm	
	900/1050	75 ppm	When using ADF 1-to-1 with A4/LT LEF magnification feeding from the same tray.

Resolution Scanning 600 dpi
 Printing 1200 dpi
 Gradation: 256 levels Scanning (8 bits/pixel)
 Printing (1 bit/pixel, 9 values):

Warm-up Time: Less than 360 s from Off mode at 23°C (73.4°F)
 First Copy Time Copy Tray 1, A4/8 1/2" x 11" LEF

	900 (90 cpm)	1050 (105 cpm)
Face-up	Less than 3.5 s	Less than 3.2 s
Face-down	Less than 5.0 s	Less than 4.2 s

Copy Number Input: 1 to 9999

Copy Paper Capacity (Sheets):	Copier	3,000	Tray 1: (Tandem) 1000 x 2 Tray 2: 500 Tray 3: 500
	LCT	4,550	Tray 4: 1,000 , Tray 5: 1,000, Tray 6: 2,550
	Bypass	500	Tray 7, 500 (Optional Bypass Tray B512)
	Total	8,050	

Memory Capacity: RAM; 256 MB (128 x 2) Standard
 256 MB (Optional, Required for Scanner/Printer Option)

HDD; 80 GB (40 GB x2), approximately 1,735 copies

Toner Replenishment: Cartridge exchange (1,450 g/cartridge)
 Toner Yield: 55 K copies, (A4 LEF, 6% chart, B070 (90 cpm) 1 to 25 Repeat Copying), (B071 (105 cpm), 1 to 50 Repeat Copying)

Power Source: North America; 208 to 240 V, 60 Hz, 20 A
 Europe/Asia; 220 to 240 V, 50/60 Hz, 16 A

Dimensions (W x D x H)
 Copier; 870 x 858.5 x 1476 mm
 32.3" x 33.8" x 58.1"
 Full System; 2218 x 8585 x 1476 mm
 87.3" x 33.8" x 58.1"

Weight: Less than 275 kg (605 lb.) including ADF, and no options

Space Requirements:

Copier (w x d) 1202 x 858.5 mm (47.3" x 33.8")

Full System*¹
(w x d)

Max.	2528 x 858.5 mm 99" x 33.7"	Finisher + Bypass with bypass tray extended for A3 SEF
Min.	2804 x 858.5 mm 110.4" x 33.7"	Finisher + Bypass with bypass tray extended for A4 LEF.

Full System: Mainframe + ADF + Finisher B478 + LCT B511 + Cover Interposer Tray B470 + Bypass Tray B512

Power Consumption: North America Version (Unit: W)

	Mainframe Only		Full System*	
	900	1050	900	1050
Warm-up	2.20 K	2.20 K	2.30 K	2.30 K
Stand-by	0.65 K	0.65 K	0.70 K	0.70 K
Copying	2.70 K	2.80 K	2.80 K	2.90 K
Maximum	2.80 K	2.90 K	2.90 K	3.00 K

*Full System: Mainframe + ADF + LCT + Bypass Tray + Cover Interposer + Finisher¹

¹ Finisher: B478 + Punch Unit with B071 (105 cpm), B468 + Punch Unit with B070 (90 cpm)

Noise Emission

900 (90 cpm)		Sound Power Level dB (A)	Sound Pressure Level dB (A)
Mainframe	Stand-by	60	45
	Copying	74	60
Full System	Stand-by	59	46
	Copying	78	68
1050 (105 cpm)		Sound Power Level dB (A)	Sound Pressure Level dB (A)
Mainframe	Stand-by	60	45
	Copying	76	61
Full System	Stand-by	59	46
	Copying	79	68

1.1.2 ADF

Original Size:	Normal Original Mode:	A3 to B5, 11" x 17" to 5 1/2" x 8 1/2"
	Thin Original Mode	A3 to B5, 11" x 17" to 5 1/2" x 8 1/2"
	Duplex Original Mode:	A3 to B5, 11" x 17" to 5 1/2" x 8 1/2"
Original Weight:	Normal Original Mode:	52~128 g/m ² (Note 1)
	Thin Original Mode	40~128 g/m ² (Note 1)
	Duplex Original Mode:	52~105 g/m ² (Note 2)
Table Capacity:	100 sheets (80 g/m ² , 20 lb)	
Original Feeding Speed:	75 cpm (A4/8 1/2" x 11" LEF, 1 to 1)	
Original Standard Position:	Rear left corner (Face-up)	
Separation:	FRR	
Original Transport:	One flat belt	
Original Feed Order:	From the top original	
Power Source:	DC 24 V and DC 38 V from the copier	
Power Consumption:	Less than 130 W	
Dimensions (W x D x H):	680 x 560 x 150 mm (26.8" x 22" x 5.9")	
Weight	Less than 17.5 kg (38.5 lb.)	

Note 1: 156 g/m² possible, but not guaranteed.

Note 2: 128 g/m² possible, but not guaranteed.

1.2 MACHINE CONFIGURATION

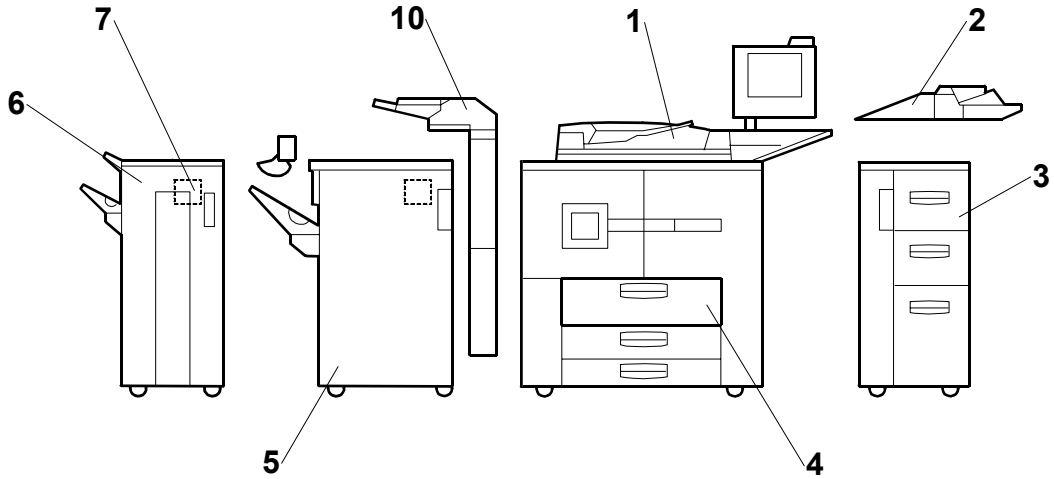

No.	Item	Machine Code	Comments
1	Mainframe	eStudio900/1050	900 (90 cpm), 1050 (105 cpm).
2	Bypass Tray	MY1024	
3	LCT	MP4501	
4	A3/DLT Tray Kit* ¹	KF9000	Replace Tray 1 (tandem tray) inside.
5	3000 Sheet Finisher	MJ1026	
6	3000 Sheet Booklet Finisher	N/A	
7	Punch Unit	N/A	
8	Output Jogger Unit	KK9000	Attached to Finisher
9	Cover Interposer Tray	MJ7002	Attached to Finisher.
10	Punch Unit	MJ6006	Inside Finisher
	Copier Connection Kit	GE1130	Not shown.

*1: Replaces Tandem Tray in main unit.

1.3 COMPONENT LAYOUT

1.3.1 COPIER ENGINE

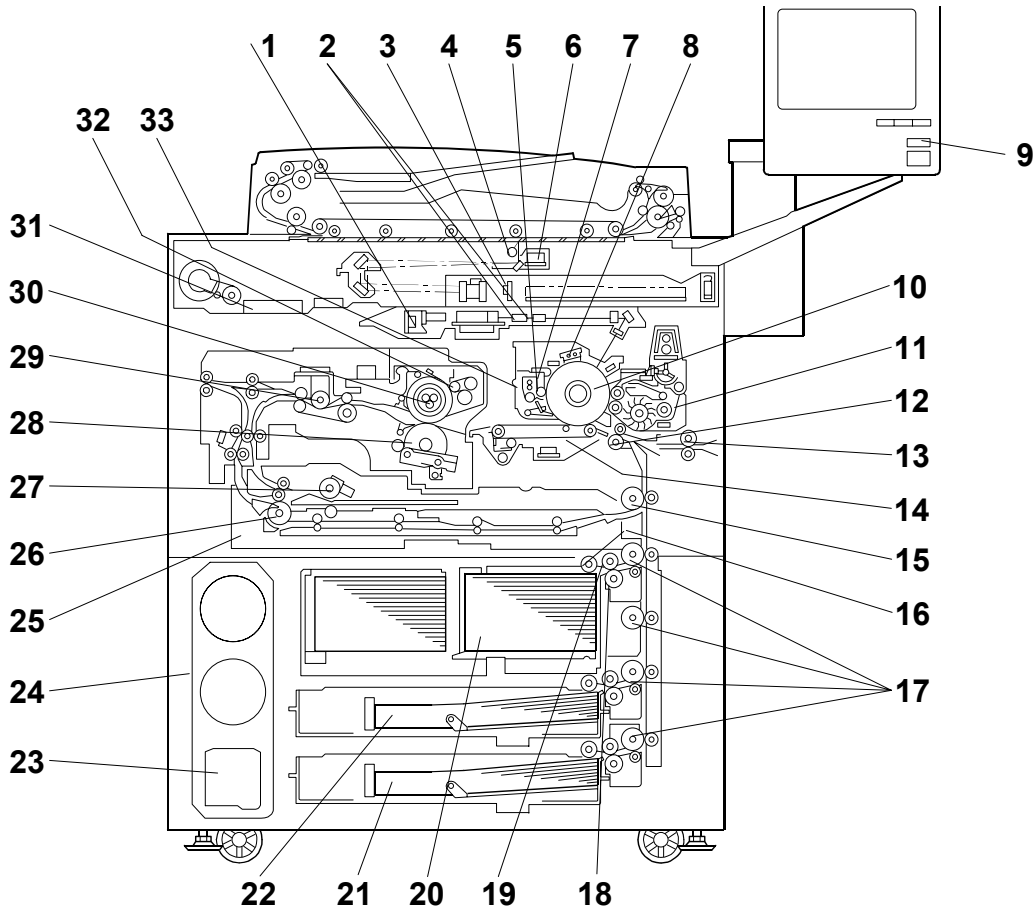

- | | |
|--------------------------------|--|
| 1. Laser Diode Board | 18. Separation Roller |
| 2. f θ Lenses | 19. Feed Roller |
| 3. Sensor Board Unit | 20. 1st Tray (Tandem, 1,000 sheets each) |
| 4. Exposure Lamp | 21. 3rd Tray (500 sheets) |
| 5. Cleaning Brush | 22. 2nd Tray (500 sheets) |
| 6. Lamp Regulator | 23. Used Toner Bottle |
| 7. Cleaning Blade | 24. Toner Bank Unit |
| 8. Charge Corona Unit | 25. Duplex Tray |
| 9. Color LCD | 26. Inverter Unit Paper Exit Roller |
| 10. Drum | 27. Inverter Feed Roller |
| 11. Development Unit | 28. Pressure Roller |
| 12. Registration Roller | 29. Paper Cooling Pipe |
| 13. LCT Relay Roller | 30. Hot Roller |
| 14. Transfer Belt Unit | 31. Motor Control Unit |
| 15. Relay Roller | 32. Oil Supply & Cleaning Web |
| 16. Pick-up Roller | 33. Drum Unit |
| 17. Vertical Transport Rollers | |

1.3.2 ADF

Overview

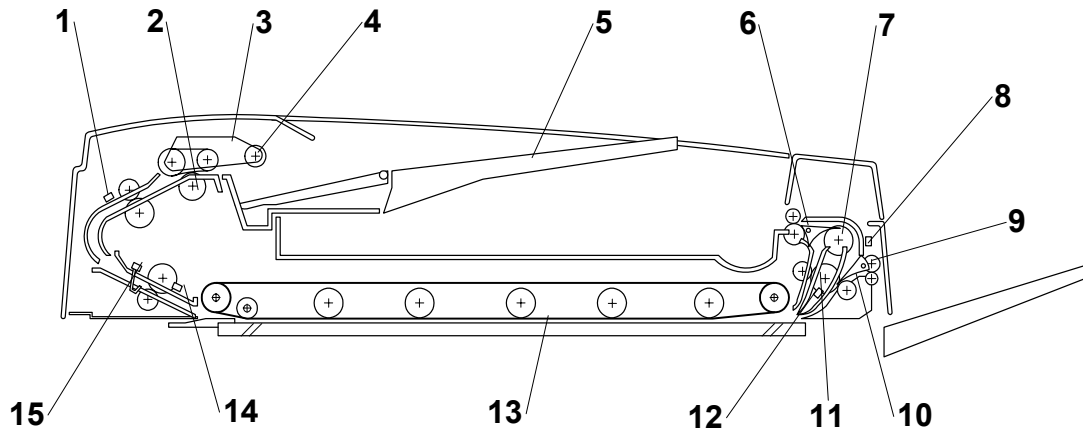

- | | |
|---------------------------|-------------------------|
| 1. Entrance Sensor | 9. Feed-out Roller |
| 2. Separation Roller | 10. Exit Junction Gate |
| 3. Feed Belt | 11. Inverter Roller |
| 4. Pick-up Roller | 12. Exit Sensor |
| 5. Original Tray | 13. Transport Belt |
| 6. Inverter Junction Gate | 14. Registration Sensor |
| 7. Inverter Guide Roller | 15. Width Sensors (x3) |
| 8. Inverter Sensor | |

1.4 PAPER PATH

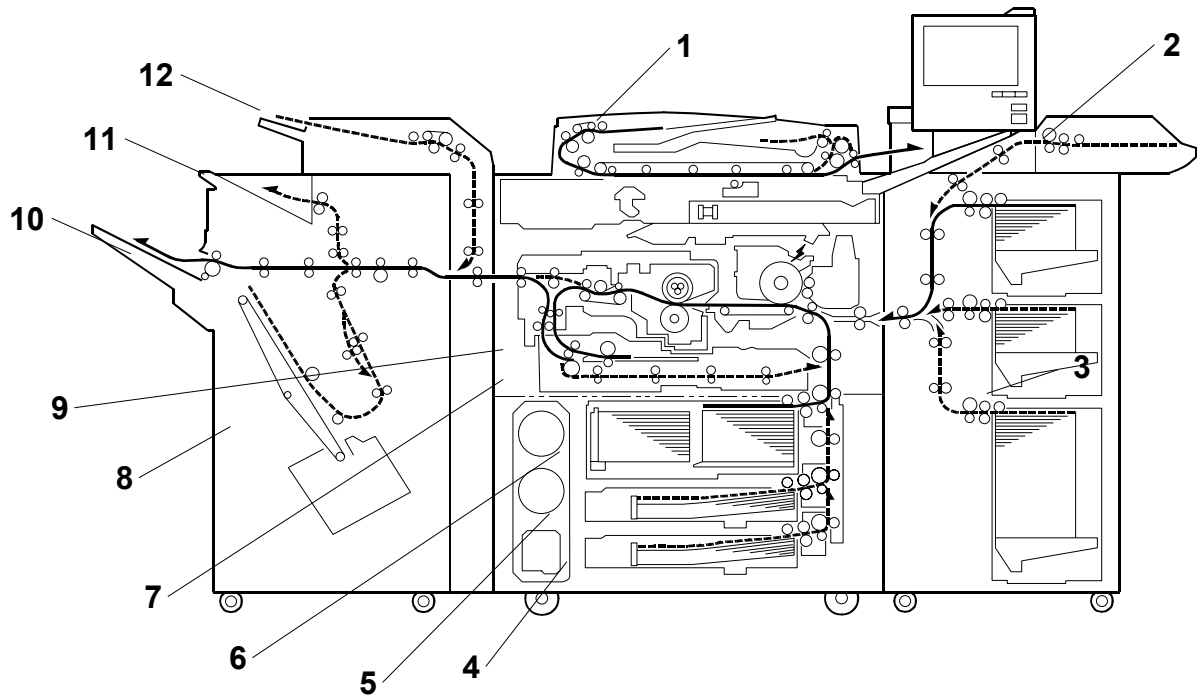

- | | |
|-----------------|----------------------|
| 1. ADF | 7. Duplex Unit |
| 2. Bypass Tray | 8. Optional Finisher |
| 3. Optional LCT | 9. Inverter Unit |
| 4. Tray 3 | 10. Shift Tray |
| 5. Tray 2 | 11. Upper Tray |
| 6. Tray 1 | 12. Cover Interposer |

1.5 COPY PROCESS

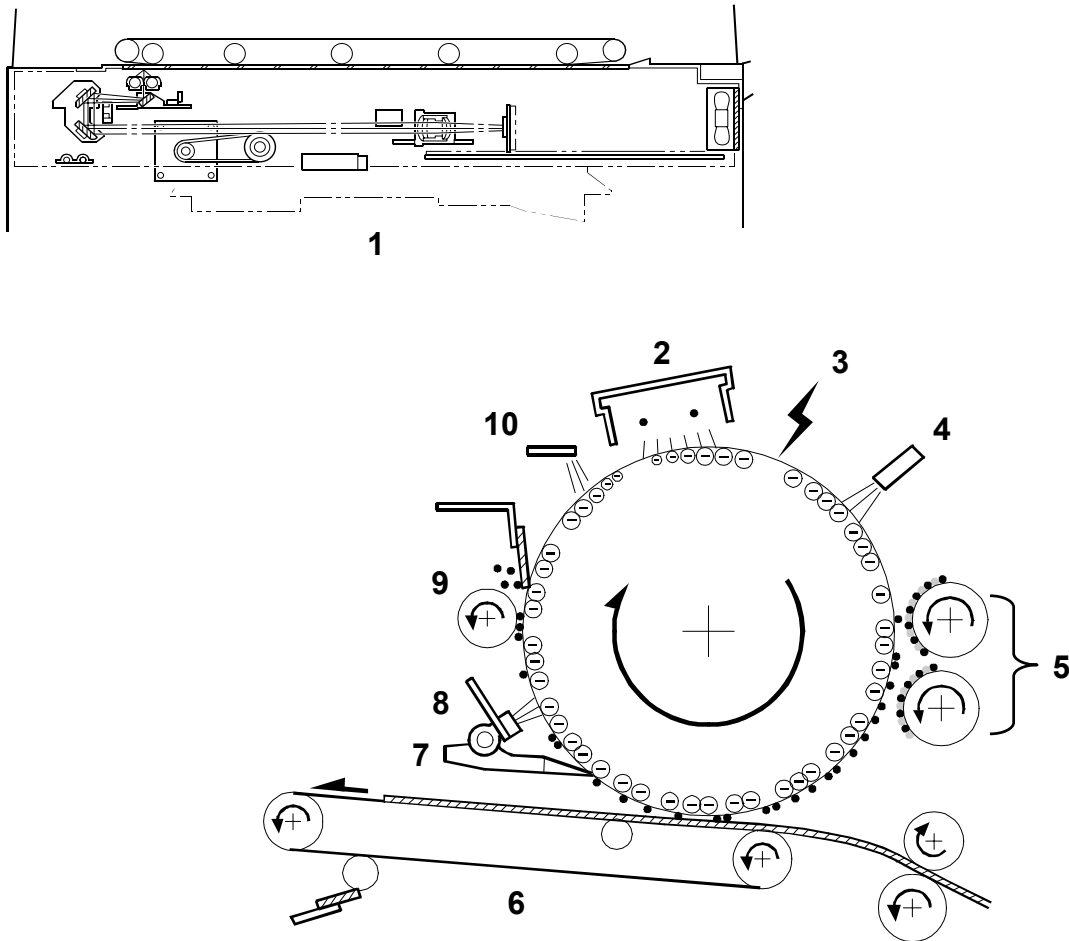

1. EXPOSURE

A xenon lamp exposes the original. Light reflected from the original passes to the CCD, where it is converted into an analog data signal. This data is converted to a digital signal, processed, and stored in the memory. At the time of printing, the data is retrieved and sent to the laser diode. For multi-copy runs, the original is scanned once only and stored to the hard disk.

2. DRUM CHARGE

An OPC (organic photoconductor) drum is used in this machine. In the dark, the charge corona unit gives a negative charge to the drum. The grid plate ensures that corona charge is applied uniformly. The charge remains on the surface of the drum because the OPC layer has a high electrical resistance in the dark.

3. LASER EXPOSURE

The processed data from the scanned original is retrieved from the hard disk and transferred to the drum by four laser beams, which form an electrostatic latent image on the drum surface. The amount of charge remaining as a latent image on the drum depends on the laser beam intensity, which is controlled by the laser diode board (LDB).

4. DRUM POTENTIAL SENSOR

The drum potential sensor detects the electric potential on the drum to correct various process control elements.

5. DEVELOPMENT

The magnetic developer brush on the development rollers comes in contact with the latent image on the drum surface. Toner particles are electrostatically attracted to the areas of the drum surface where the laser reduced the negative charge on the drum.

6. IMAGE TRANSFER

Paper is fed to the area between the drum surface and the transfer belt at the proper time to align the copy paper and the developed image on the drum. Then, the transfer bias roller and brush apply a high positive charge to the reverse side of the paper through the transfer belt. This positive charge pulls the toner particles from the drum to the paper. At the same time, the paper is electrically attracted to the transfer belt.

7. PAPER SEPARATION

Paper separates from the drum as a result of the electrical attraction between the paper and the transfer belt. The pick-off pawls also help separate the paper from the drum.

8. ID SENSOR

The laser forms a sensor pattern on the drum surface. The ID sensor measures the reflectivity of the pattern. The output signal is one of the factors used for toner supply control.

9. CLEANING

The cleaning brush removes toner remaining on the drum after image transfer and the cleaning blade scrapes off all remaining toner.

10. QUENCHING

The light from the quenching lamp electrically neutralizes the charge on the drum surface.

SECTION 2

DETAILED DESCRIPTIONS

2. DETAILED SECTION DESCRIPTIONS

2.1 DOCUMENT FEEDER

2.1.1 PICK-UP ROLLER RELEASE

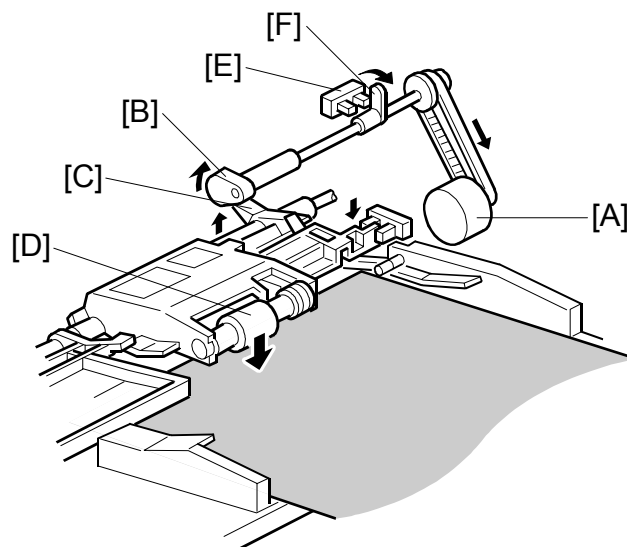

When the original set sensor is off (no original on the original tray), the pick-up roller stays in the up position.

When the original set sensor turns on (or when the trailing edge of a page passes the entrance sensor while pages remain on the original tray), the pick-up motor [A] turns on. The cam [B] rotates away from the pick-up roller release lever [C]. The lever then rises and the pick-up roller [D] drops onto the original.

When the original reaches the entrance sensor, the pick-up motor turns on again. The cam pushes the lever down, and the pick-up roller rises until the pick-up roller HP sensor [E] detects the actuator [F].

2.1.2 BOTTOM PLATE LIFT

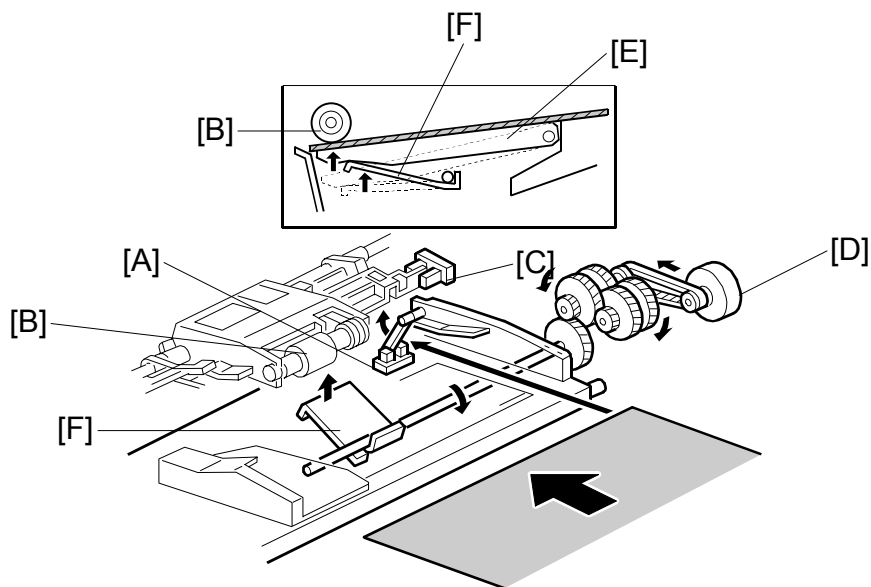

When an original is placed on the original tray, the original set sensor [A] turns on, the pick-up roller [B] drops on to the original, and the bottom plate position sensor [C] turns off. Then the bottom plate motor [D] turns on and lifts the bottom plate [E] by raising the lift lever [F] until the bottom plate position sensor turns on.

The level of the pick-up roller drops as the stack of originals becomes smaller, and eventually, the bottom plate position sensor [C] turns off. Then, the bottom plate motor turns on and lifts the bottom plate until the bottom plate position sensor turns on. This keeps the original at the correct height for feeding.

2.1.3 PICK-UP AND SEPARATION

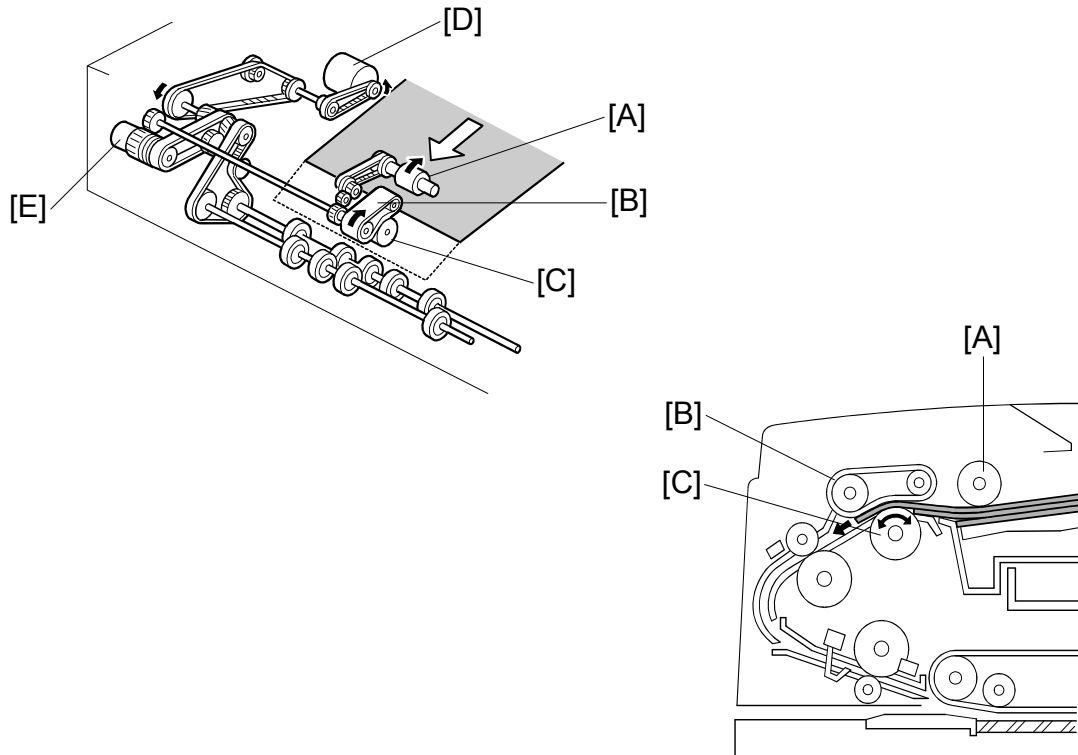

The original separation system is a Feed and Reverse Roller (FRR) system. The pick-up roller [A], feed belt [B], and separation roller [C] are driven by the feed-in motor [D]. To drive this mechanism, the feed-in motor [D] and feed-in clutch [E] turn on.

( Handling Paper> Handling Originals> Document Feed> **FRR with Feed Belt**)

2.1.4 ORIGINAL FEED

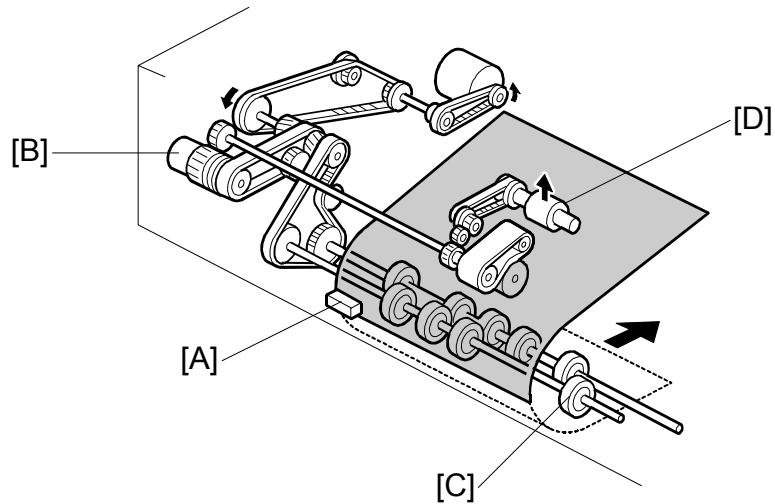

When the leading edge of the original turns the entrance sensor [A] on, the feed-in clutch [B] turns off and the drive for the feed belt is released. The original is fed by the transport rollers [C].

At the same time, the pick-up motor starts again and the pick-up roller [D] is lifted up. When the pick-up roller HP sensor turns on, the pick-up motor stops (see Pick-up Roller Release).

2.1.5 ORIGINAL SIZE DETECTION

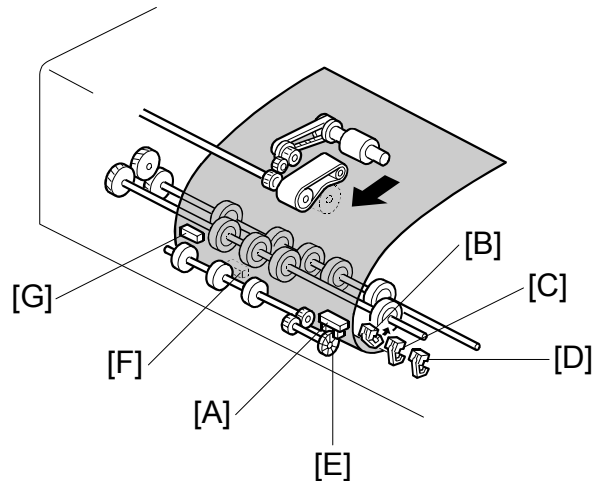

The ADF detects the original size by combining the readings of original length sensor [A], and original width sensors-1 [B], -2 [C], and -3 [D].

Original Length

The original length sensor and the disk [E] (connected to the transport roller) generate a pulse signal. The CPU counts pulses, starting when the leading edge of the original turns on the registration sensor [F], until the trailing edge of the original turns off the entrance sensor [G].

Original Width

The CPU detects original width using three original width sensors -1, -2, -3 as shown above. Three small circles on the diagram indicate the positions of the sensors.

Original Width Sensor Location

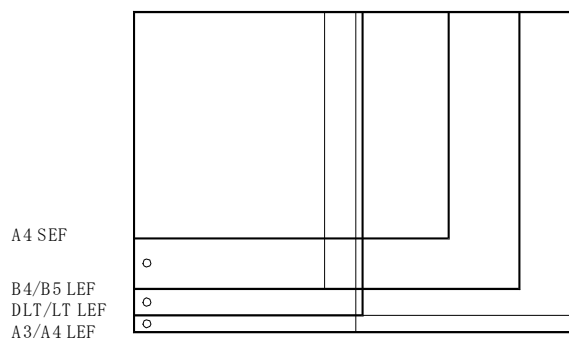

Detectable Paper Sizes

Please refer to the “1.2 ADF” table in “Specifications”.

2.1.6 ORIGINAL TRANSPORT

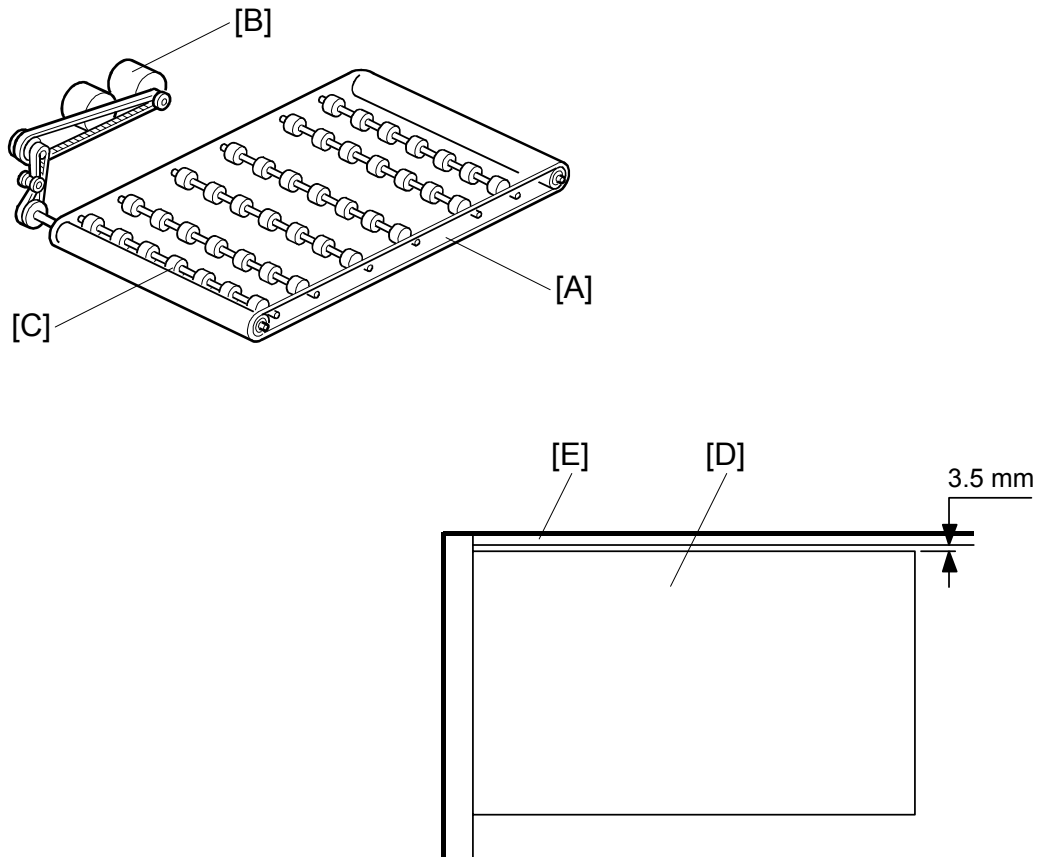

The transport belt [A] is driven by the transport belt motor [B]. The transport belt motor starts when the copier sends an original feed-in signal.

The pressure rollers inside the transport belt maintain the correct pressure between belt and original. The pressure roller [C] closest to the left original scale is made of rubber for the stronger pressure needed for thick originals. The other rollers are sponge rollers.

Normally, originals are manually placed at the left rear corner, so an original [D] fed from the ADF must also be at this position. But if the original touches the rear scale [E] as it feeds, original skew, jam, or wrinkling may occur.

To prevent such problems, the original transfer position is set to 3.5 mm away from the rear scale as shown. The 3.5 mm gap is compensated for by changing the starting position of the main scan for when the image is exposed on the drum.

2.1.7 ORIGINAL SKEW CORRECTION

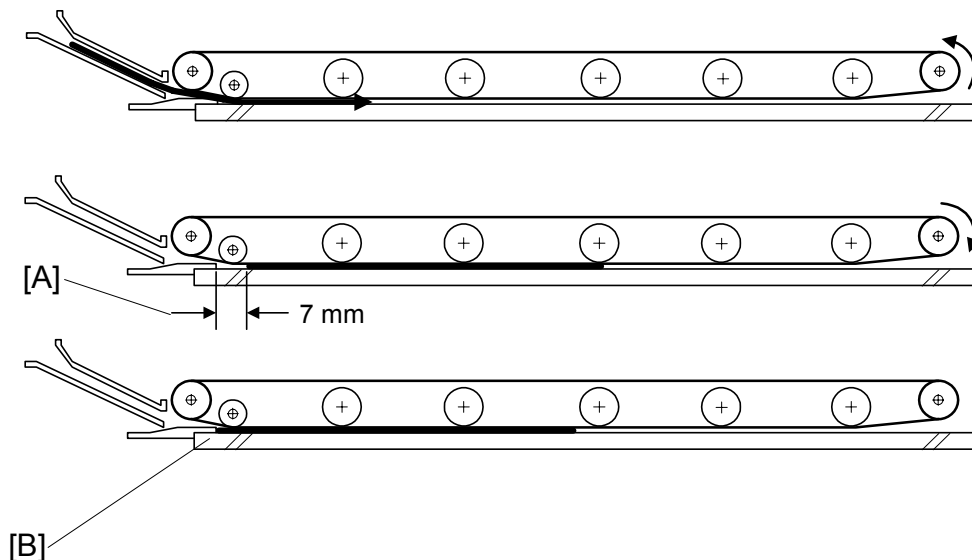

The transport belt motor remains energized to carry the original to the right about 7 mm past the left scale [A]. Then the motor stops and reverses to feed the original 12 mm to the left against the left scale to correct skew. This forces the original to hit the left scale, which aligns the trailing edge to minimize original skew on the exposure glass.

If thin original mode is selected, the original is not forced back against the left scale. This is to prevent damage to the original.

After a two-sided original has been inverted to copy the 2nd side, it is fed in from the inverter against the left scale [B] without skew correction.

NOTE: The bottom drawing applies to duplex scanning; the top two drawings do not apply in this mode.

The amount of reverse feed against the left scale can be adjusted as follows:

- One-sided originals, and side 1 of two-sided originals: SP6006-3 (DF Registration Adjustment – Leading Edge Duplex 1st)
- Side 2 of two-sided originals: SP6006-4 (DF Registration Adjustment – Leading Edge Duplex 2nd).

2.1.8 ORIGINAL INVERSION AND FEED-OUT

General Operation

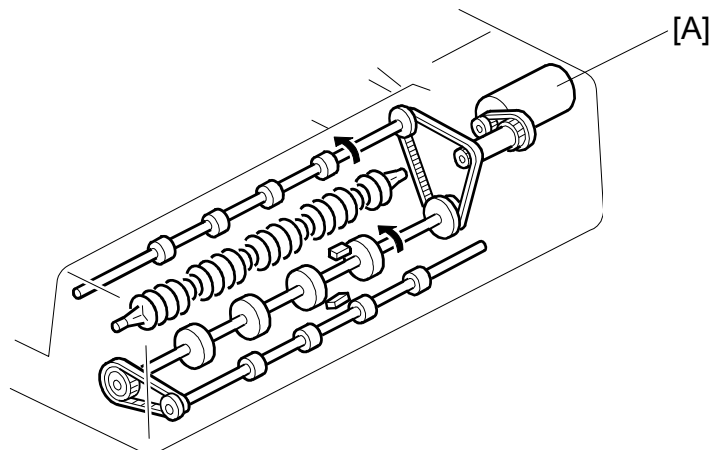

When the scanner reaches the return position, the copier CPU sends the feed-out signal to the ADF. When the ADF receives the feed-out signal, the transport belt motor and feed-out motor [A] turn on. The original is then fed out to the exit tray or fed back to the exposure glass after reversing in the inverter section.

This ADF has two exit trays. For single-sided original mode, the original is fed out straight out to the right exit tray, but for double-sided original mode, the original is fed out to the upper exit tray.

This causes the originals to be fed out in the correct order on the exit trays and allows the maximum one-to-one copy speed for each mode.

Original Inversion

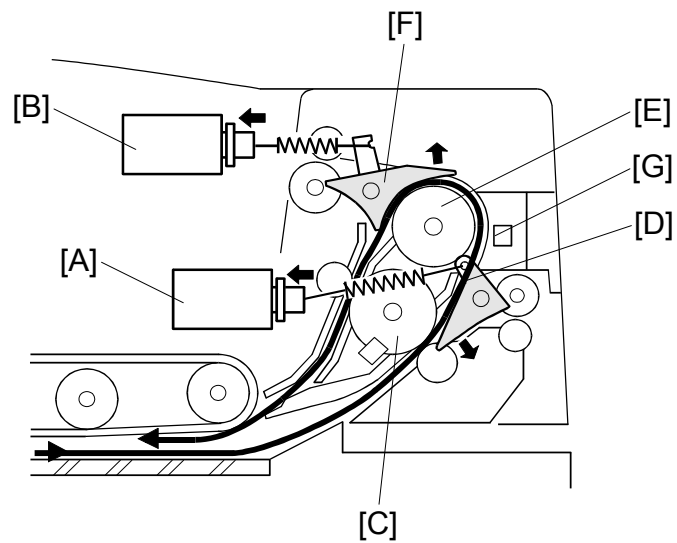

When the ADF receives the original invert signal from the copier, the transport belt motor, feed-out motor, exit gate solenoid [A], and inverter gate solenoid [B] turn on and the original is fed back to the exposure glass through the inverter roller [C], exit gate [D], inverter guide roller [E], inverter gate [F], and inverter roller.

The transport belt motor reverses shortly after the leading edge of the original turns on the inverter sensor [G], and feeds the original to the left scale.

Original Exit (Single-Sided Original Mode)

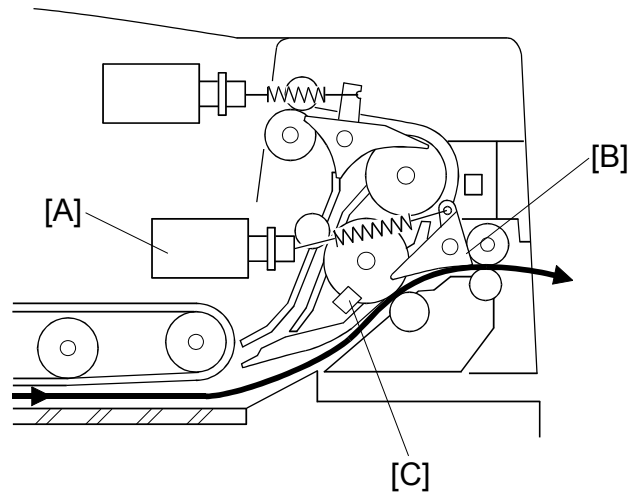

The exit gate solenoid [A] remains off, the exit gate [B] remains closed, and the original is fed out to the right exit tray.

The speed of the motor is reduced about 30 mm from the trailing edge of the original to ensure the originals stack neatly on the exit tray. This timing is determined by the length of the original, and the time since the exit sensor [C] detected the leading edge. The transport belt motor turns off after the exit sensor [C] turns off.

Original Exit (Double-Sided Original Mode)

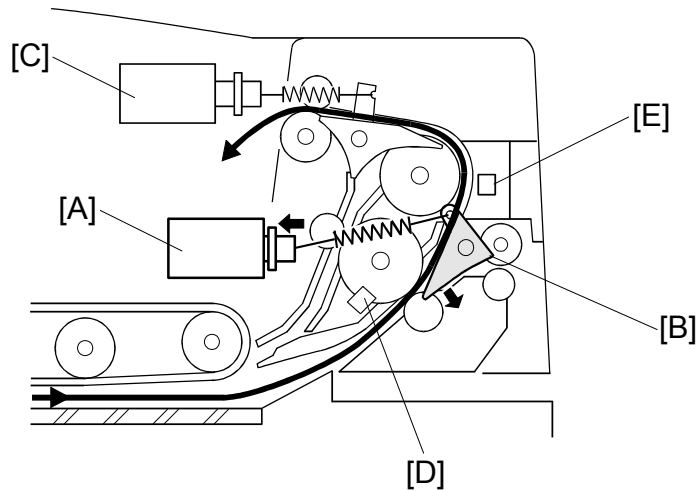

The exit gate solenoid [A] turns on and the exit gate [B] opens.

The inverter gate solenoid [C] remains off, and the original is fed out to the upper tray. The transport belt motor turns off when the trailing edge of the original passes the exit sensor [D].

To stack the originals neatly on the upper tray, the feed-out motor speed is reduced shortly after the trailing edge of the original turns off the inverter sensor [E].

2.2 SCANNING

2.2.1 OVERVIEW

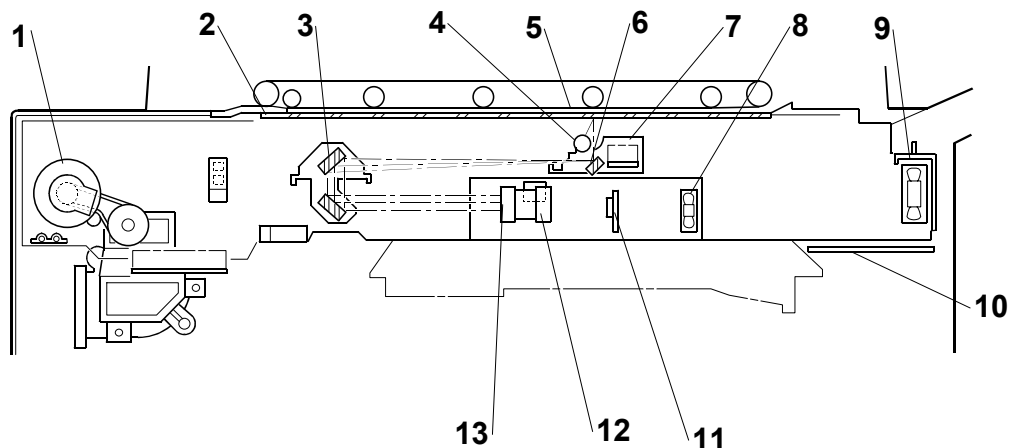

- | | |
|------------------------------------|--|
| 1. Scanner Motor | 10. LCDC (LCD Control Board) |
| 2. White Plate (on exposure glass) | 11. CCD (Charge Coupled Device) |
| 3. 2nd Mirror | 12. Original Length Sensor (APS) |
| 4. Exposure Lamp (Xenon) | 13. Scanner Lens |
| 5. Exposure Glass | 14. 3rd Mirror |
| 6. 1st Mirror | 15. Original Width Sensors 1, 2, 3 (APS) |
| 7. Lamp Regulator | 16. Scanner HP Sensor |
| 8. SBU Cooling Fan | 17. Optics Anti-condensation Heater (option) |
| 9. Optics Cooling Fan | |

One xenon lamp (23W) as the exposure lamp [4] illuminates the original. The image is reflected onto the CCD [11] (600 dpi resolution) via the 1st, 2nd, and 3rd mirrors, and through the lens [13].

The lens, CCD, and SBU are in a single unit, the lens block. The optical axis, focus, and MTF are pre-adjusted, so this lens block requires no adjustment in the field. The 1st scanner consists of the exposure lamp [4], the lamp regulator [7] and the 1st mirror.

Two fans, the optics cooling fan [9] and the SBU cooling fan [8], draw cool air into the scanning unit. The optics cooling fan turns on when the scanner motor starts and turns off 10 seconds after the scanner motor turns off. The SBU cooling fan operates while the operation switch is on. The optional optics anti-condensation heater [17] (if installed as an option) turns on while the main switch is off, to prevent moisture from forming on the optics.

2.2.2 SCANNER DRIVE

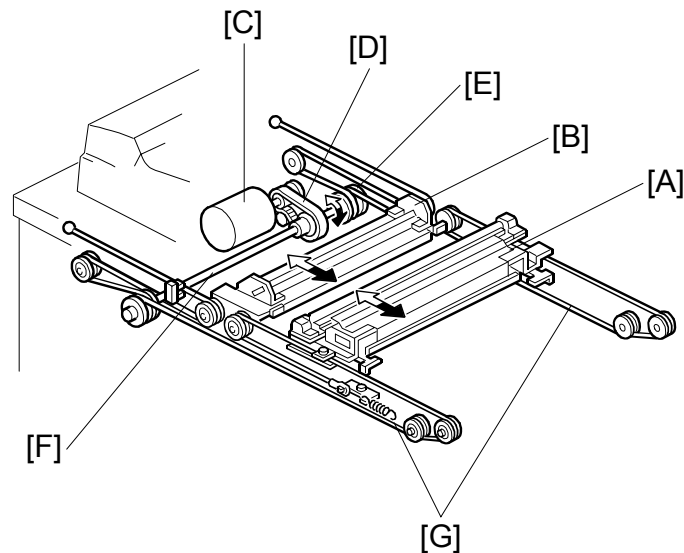

The scanner motor is a dc servo motor. The 1st and 2nd scanners [A, B] are driven by the scanner motor [C] through the timing belt [D], scanner drive pulley [E], scanner drive shaft [F], and two scanner wires [G].

The MCU (Motor Control Unit) board controls the scanner motor. The exposure lamp scans a sheet with 100% magnification at 515 mm/s and returns to the scan position for the next scan at 2500 mm/s.

Magnification and Reduction

Magnification and reduction in the main scan direction are done in the IPU board.

Magnification and reduction in the sub scan direction, however, are done by controlling the speed of the scanner motor in sync with the main scan processing done in the IPU.

- Magnification above 101% is done in the IPU. For example, at 200% magnification, the IPU doubles magnification while the scanner motor speed remains at 100%.
- Reduction in the range 51% to 100% is done by the scanner motor.
- Reduction in the range 25% to 50% is done by the scanner motor, assisted by IPU processing. For example, at 40% reduction, the scanner motor speed is 80% and the IPU reduces the image by 1/2.
- Reduction below 25% is done by the scanner motor, assisted by IPU processing. For example, at 24% reduction the scanner motor speed is 96% and the IPU reduces the image by 1/4.

NOTE: Magnification in the sub scan direction can be adjusted by changing the scanner motor speed with SP4008 (Scanner Sub Scan Magnification).

2.2.3 ORIGINAL SIZE DETECTION

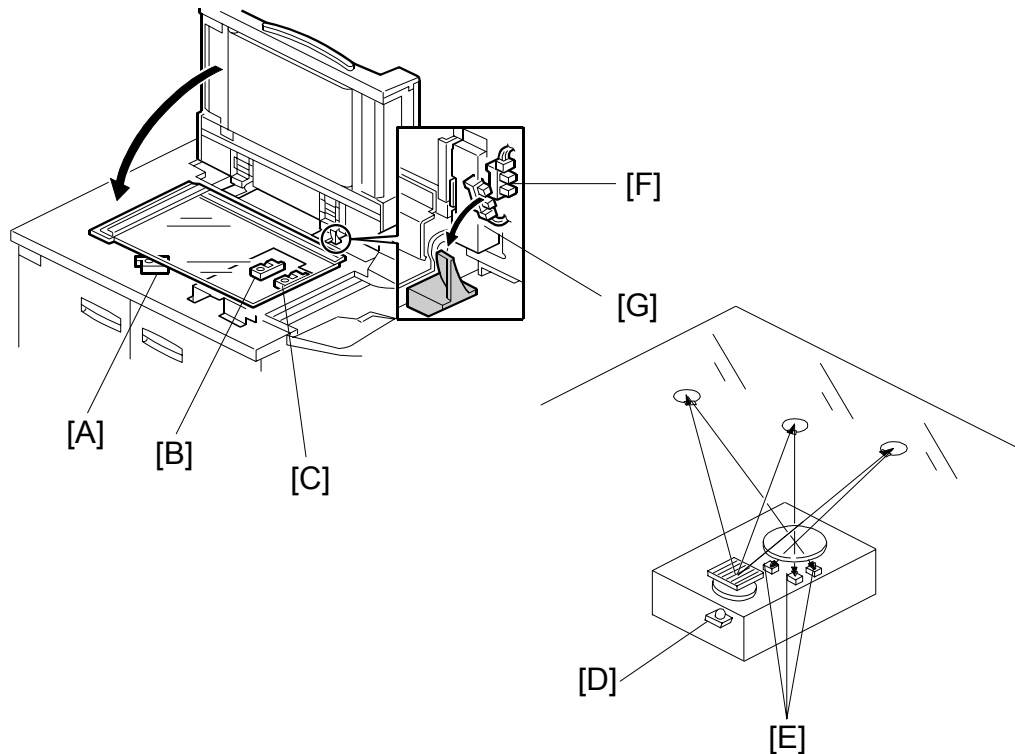

There are three reflective sensors at three locations in the optics cavity for original size detection.

The original width sensor [A] detects the original width, and the original length sensor 1 [B] and original length sensor 2 [C] detect the original length. These are the APS (Auto Paper Select) sensors.

Inside each APS sensor, there is an LED [D] and either three photoelectric devices [E] (for the width sensor) or one photoelectric device (for each length sensor). In the width sensor, the light generated by the LED is separated into three beams and each beam scans a different point of the exposure glass (in each length sensor, there is only one beam). If the original or ADF cover is present over the scanning point, the beam is reflected and each reflected beam exposes a photoelectric device and activates it.

While the main switch is on, these sensors are active and the original size data is always sent to the main CPU. However, the main CPU checks the data only when the ADF is being closed.

The ADF functions as the platen. The DF position sensor [F] (attached to the ADF) detects whether the ADF is open or closed.

The APS start sensor [G] triggers auto paper size detection.

NOTE: The Europe/Asia model has one length sensor (L1), but the North American model has two length sensors (L1, L2)

Original Size		Length Sensor		Width Sensor			SP4301 Display
A4/A3 Version	LT/DLT Version	2	1	1	2	3	
A3	11" x 17"	H	H	H	H	H	00011111
B4	10" x 14"	H	H	H	H	L	00011110
F4	8 1/2" x 14" (8" x 13")	H	H	H	L	L	00011100
A4 SEF	8 1/2" x 11"	L	H	H	L	L	00001100
B5 SEF	—	L	H	L	L	L	00001000
A5 SEF	5 1/2" x 8 1/2"	L	L	L	L	L	00000000
A4 LEF	11" x 8 1/2"	L	L	H	H	H	00000111
B5 LEF	—	L	L	H	H	L	00000110
A5 LEF	8 1/2" x 5 1/2"	L	L	H	L	L	00000100

H:High (Paper Present) L: Low

The original size data is taken by the main CPU when the DF position sensor is activated. This is when the ADF is positioned about 12 cm above the exposure glass. At this time, only the sensor(s) underneath the original receive the reflected light and switch on. The other sensor(s) are off. The main CPU recognizes the original size from the on/off signals from the five sensors.

If the copy is made with the ADF open, the main CPU decides the original size from the sensor outputs when the Start key is pressed.

The above table shows the outputs of the sensors for each original size. This original size detection method eliminates the necessity for a pre-scan and increases the machine productivity.

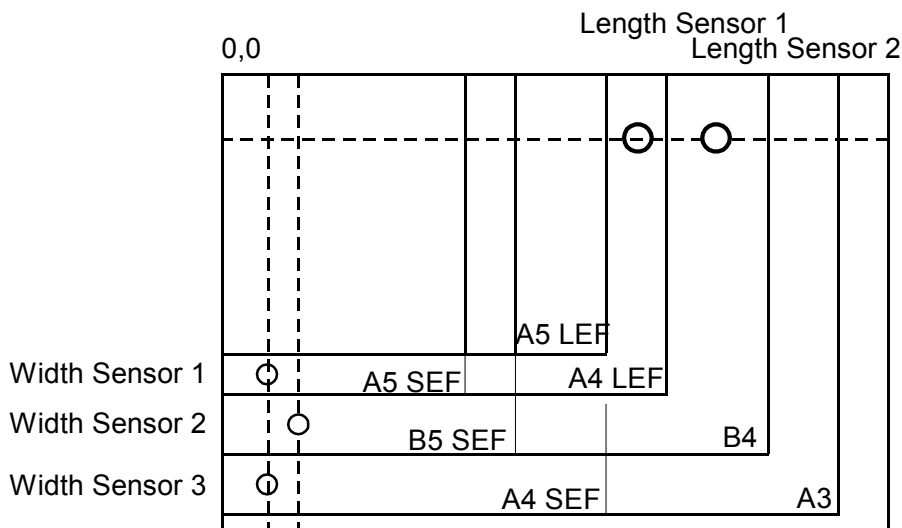

2.3 IMAGE PROCESSING

2.3.1 IMAGE PROCESSING STEPS AND RELATED SP MODES

The following tables describe the image processing path and the related SP modes used for each image processing mode.

The user can adjust many of the image processing parameters with a UP mode (Copy/Document Server Features> General Features> Original Mode Quality Level), using fixed settings such as Sharp, Normal, and Soft. Each of these fixed settings have different parameters, but user changes do not affect the relevant SP mode settings.

If the user is not satisfied with any of the available settings for this UP mode, the technician can adjust the SP modes. However, the SP mode settings are not used unless the user selects 'Service Mode' with the UP Mode.

▶ Text	Soft	Normal	Sharp	Service Mode
▶ Text/Photo	Photo Priority	Normal	Text Priority	Service Mode
▶ Photo	Screened Printed	Normal	Glossy Phot	Service Mode
▶ Pale	Soft	Normal	Sharp	Service Mode
▶ Generation	Soft	Normal	Sharp	Service Mode

2.3.2 IMAGE PROCESSING OVERVIEW

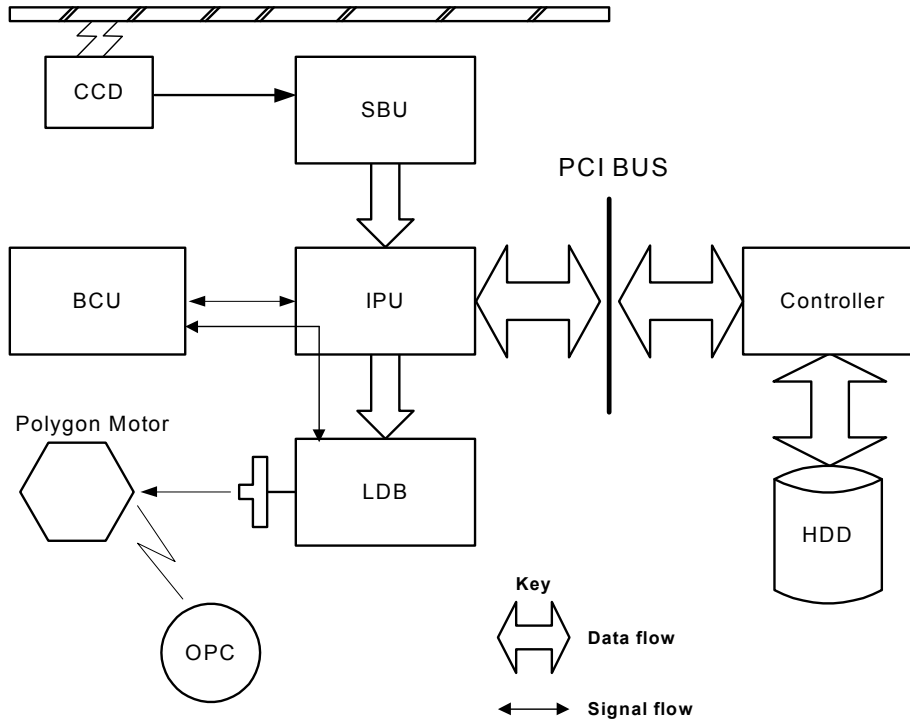

- SBU:** Photoelectric conversion, Odd/even allocation, Amplification, A/D Conversion (analog to digital), Light intensity detection (scanning)
- BCU:** Engine control, Scanner control, SBU settings, IPU settings, LDB settings
- IPU:** Shading correction, Image Processing, Main/Sub scan magnification, Video path switching, Image Compression/Decompression. The GAVD on this board performs density conversion processing, FCI processing, and edge processing, and also generates the test patterns.
- Controller:** System control, software application control, image storage control, file compression/decompression
- LDB:** 8-beam laser exposure, binary-to-grayscale conversion, synchronization detection

2.3.3 IMAGE PROCESSING FLOW

Image processing is done by the IPU (Image Processing Unit), following the steps shown below.

Overall image processing for this machine is designed to:

- Target edges with filters to improve the angles of text characters and reduce the occurrence of moiré filled areas.
- Improve the evenness of granular areas in images

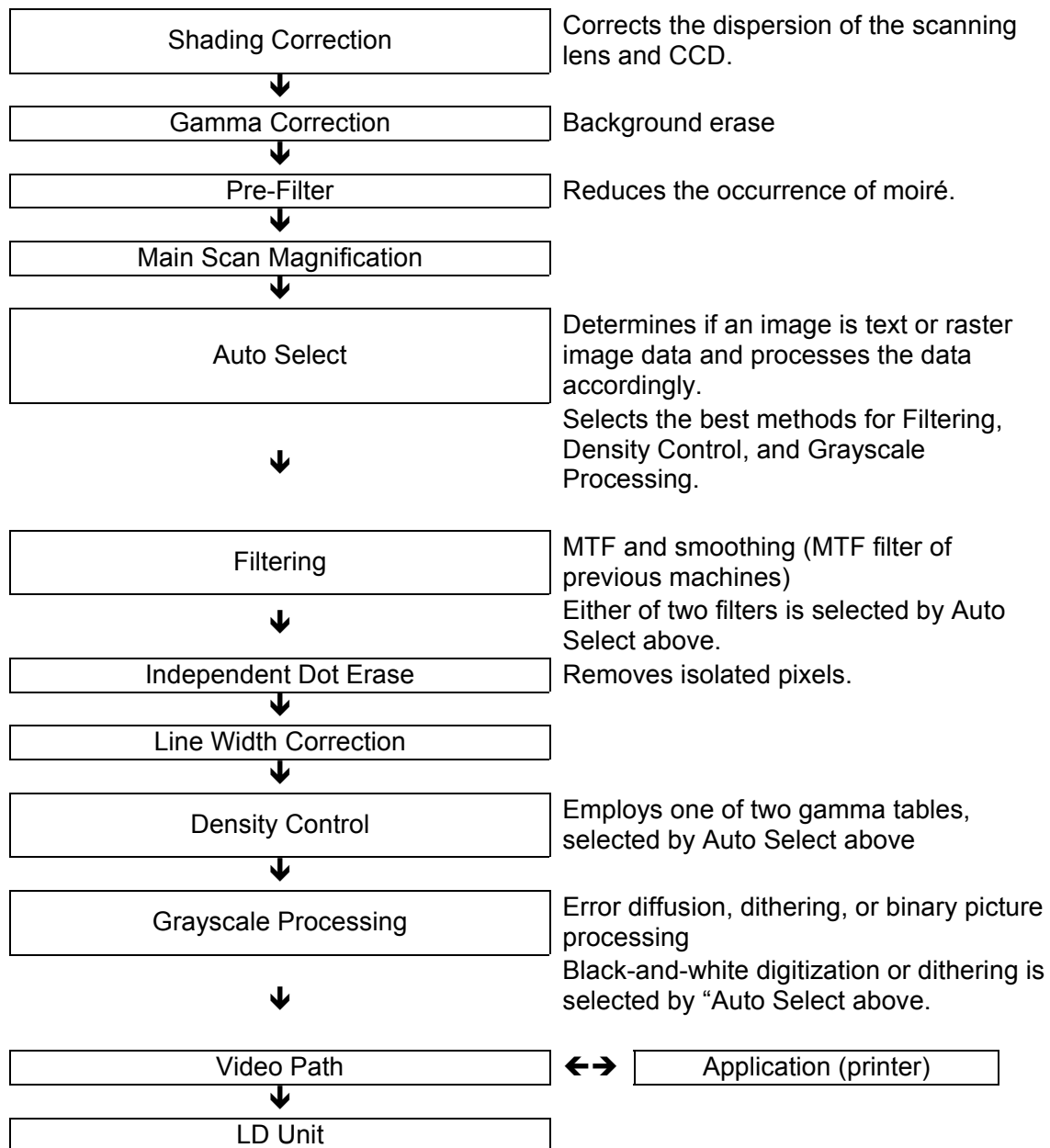

2.3.4 IMAGE PROCESSING MODES

The user can select one of the following five modes with the User Tools screen: Text, Text/Photo, Photo, Pale, Generation.

Each mode has four different settings (described below). Each mode has a Custom Setting that can be customized with SP modes to meet special requirements that cannot be covered by the standard settings.

NOTE: To see these settings in the User Tools mode, press the User Tools key, press “Copier/Document Server Functions”, then press “Copy Quality”.

Mode	Setting	Function
Text	Soft	Rough texture background drops out.
	Normal	Used for black-and-white printed material and documents that contain mainly text. Easily reads lines as well as text.
	Sharp	Use for newspapers, time schedules, or any type of printed material with fine print. Emphasizes black over white.
	Custom Setting	Stores SP command settings.
Tex/Photo	Photo Priority	Used for documents that contain text and color or black-and-white photos, such as catalogs, magazines, maps, etc. Provides more faithful reproduction than the Text mode.
	Normal	
	Text Priority	
	Custom Setting	Stores SP command settings.
Photo	Print Photo	Used for magazines, graphics, for smooth reproduction. Employs dithering.
	Normal	Used for copying photographs, graphics, for sharp reproduction. Employs error diffusion.
	Glossy Photo	Used for best results in copying glossy photographs for sharp reproduction. Employs error diffusion.
	Custom Settings	Stores SP command settings. Employs either error diffusion or dithering, depending on an SP setting.
Pale	Soft	Used for low density documents with text handwritten in black or color pencil (or carbon copies) such as receipts, invoices, etc.
	Normal	
	Sharp	
	Custom Setting	Stores SP command settings.
Generation Copy	Soft	Used to achieve an image smoother than Normal.
	Normal	Used to achieved best reproduction of “copies of copies” by smoothing the image.
	Sharp	Used to emphasize lines and text stronger than Normal for better image quality.

	Custom Setting	Stores SP command settings.
Background Dropout	Strong	Drops out the blue background color of tab sheets or other paper.
	Medium	Drops out the green background color of tab sheets or other paper.
	Weak	Drops out the orange background color of tab sheets or other paper.

2.3.5 IMAGE QUALITY SP ADJUSTMENTS

Adjustments are easier with this machine, because the parameters have been grouped and no longer have to be adjusted one by one.

In this section, we will cover the custom settings for each of the 5 original modes: These custom settings are:

- Image Quality
- Line Width Correction

Settings adjustable for each original mode will also be covered (these do not just affect the custom settings; they also affect all sub original modes, such as sharp text).

- Independent Dot Erase
- Background Erase

Custom Settings for Each Mode: Image Quality

Custom Setting: Text Mode Image Quality

Item	Range	Default	SP No.	
Text	25~55%	0~10	5 Normal	SP4903 001
	55.5~75%			SP4903 002
	75.5~160%			SP4903 003
	160.5~400 %			SP4903 004

If the value is increased, the outlines of lines become sharper but this could cause moiré to appear in dot patterns. If the value is decreased, image patterns become smoother, the occurrence of moiré decreases, but the corners of characters and intersections of lines at acute angles may not be as sharp.

There are two sets of custom settings for photo mode. One is for dithering, and one is for error diffusion. The set of custom settings that will be used depends on the setting of SP4904 002. The possible settings are:

0	Dither (106 line)
1	Dither (141 line)
2	Dither (212 line)
3	Error Diffusion

Custom Setting: Photo Mode (Dithering) Image Quality

Item	Range	Default	SP No.	
Photo	25~55%	0~6	3 Print Photo	SP4903 005
	55.5~75%			SP4903 006
	75.5~160%			SP4903 007
	160.5~400%			SP4903 008

Used for coarse, dithered tone photographs such as newsprint.

If the value is increased, the photo becomes sharper, but blurring could occur in the sub scan direction. If the value is decreased, blurring in the sub scan direction is less obvious but outlines become fuzzy.

Custom Setting: Photo Mode (Error Diffusion) Image Quality

Item	Range	Default	SP No.	
Photo	25~55%	0~6	1 Normal	SP4903 009
	55.5~75%			SP4903 010
	75.5~160%			SP4903 011
	160.5~400%			SP4903 012

Used for printed materials (magazines, etc.) with photographs to sharp patterns in copies.

If the photos have dithered tones, the image becomes sharper if the value is increased, but blurring could occur in the sub scan direction. If the value is decreased, blurring in the sub scan direction is less obvious but outlines become fuzzy.

Custom Setting: Text/Photo Mode Image Quality

Item	Range	Default	SP No.	
Text/Photo	25~55%	0~10	5 Normal	SP4903 013
	55.5~75%			SP4903 014
	75.5~160%			SP4903 015
	160.5~400%			SP4903 016

See the remarks for 'Custom Setting: Text Mode Image Quality' above.

Custom Setting: Pale Mode Image Quality

Item	Range	Default	SP No.	
Pale	25~55%	0~10	5 Normal	SP4903 017
	55.5~75%			SP4903 018
	75.5~160%			SP4903 019
	160.5~400%			SP4903 020

If the value is increased, low density areas become sharper, but the background could become dirtier. If the value is decreased, the background disappears but the density of low density areas becomes low.

Custom Setting: Generation Mode Image Quality

Item	Range	Default	SP No.	
Generation	25~55%	0~10	5 Normal	SP4903 021
	55.5~75%			SP4903 022
	75.5~160%			SP4903 023
	160.5~400%			SP4903 024

See the remarks for 'Custom Setting: Pale Mode Image Quality' above.

Custom Settings for Each Mode: Line Width Correction

Custom Setting: Text Mode Line Width Correction

Selection		Range	Default	Content	SP No.
Item	Line Width Correction	0~8	2	0 (Thin) - 4 (Off) - 8 (Thick)	SP4903 080
	Main Scan	0~1	1	0:OFF 1:ON	SP4903 081
	Sub Scan	0~1	1	0:OFF 1:ON	SP4903 082

If the value is made smaller, the line width correction becomes thinner, and if the value is made larger, the line width correction becomes thicker. To switch this feature off, select "4".

If the above settings do not make the lines thin enough, use SP4904 020 (Image Quality Exposure: Thin Line - Text Mode). Normally, SP4904 020 is set to 0 (OFF). As the setting is increased (1~3), the line width correction effect becomes stronger, and lines become thinner. All settings of SP4903 080 will be affected by the same amount.

Custom Setting: Photo Mode Line Width Correction

Selection		Range	Default	Content	SP No.
Item	Line Width Correction	0~8	4	0 (Thin) - 4 (Off) - 8 (Thick)	SP4903 083
	Main Scan	0~1	1	0:OFF 1:ON	SP4903 084
	Sub Scan	0~1	1	0:OFF 1:ON	SP4903 085

See the remarks for 'Custom Setting: Text Mode Line Width Correction' above.

If the above settings do not make the lines thin enough, use SP4904 021 (Image Quality Exposure: Thin Line – Photo Mode). Normally, SP4904 021 is set to 0 (OFF). As the setting is increased (1~3) the line width correction effect becomes stronger, and lines become thinner. All settings of SP4903 083 will be affected by the same amount.

Custom Setting: Text/Photo Mode Line Width Correction

Selection		Range	Default	Content	SP No.
Item	Line Width Correction	0~8	4	0 (Thin) - 4 (Off) - 8 (Thick)	SP4903 086
	Main Scan	0~1	1	0:OFF 1:ON	SP4903 087
	Sub Scan	0~1	1	0:OFF 1:ON	SP4903 088

See the remarks for 'Custom Setting: Text Mode Line Width Correction' above.

If the above settings do not make the lines thin enough, use SP4904 022 (Image Quality Exposure: Thin Line – Text/Photo Mode). Normally, SP4904 022 is set to 0 (OFF). As the setting is increased (1~3) the line width correction effect becomes stronger, and lines become thinner. All settings of SP4903 086 will be affected by the same amount.

Custom Setting: Pale Mode Line Correction

Selection		Range	Default	Content	SP No.
Item	Line Width Correction	0~8	4	0 (Thin) - 4 (Off) - 8 (Thick)	SP4903 089
	Main Scan	0~1	1	0:OFF 1:ON	SP4903 090
	Sub Scan	0~1	1	0:OFF 1:ON	SP4903 091

See the remarks for 'Custom Setting: Text Mode Line Width Correction' above.

If the above settings do not make the lines thin enough, use SP4904 023 (Image Quality Exposure: Thin Line – Pale Mode). Normally, SP4904 023 is set to 0 (OFF). As the setting is increased (1~3) the line width correction effect becomes stronger, and lines become thinner. All settings of SP4903 089 will be affected by the same amount.

Custom Setting: Generation Copy Line Width Correction

Selection		Range	Default	Content	SP No.
Item	Line Width Correction	0~8	1	0 (Thin) - 4 (Off) - 8 (Thick)	SP4903 092
	Main Scan	0~1	1	0:OFF 1:ON	SP4903 093
	Sub Scan	0~1	1	0:OFF 1:ON	SP4903 094

See the remarks for 'Custom Setting: Text Mode Line Width Correction' above.

If the above settings do not make the lines thin enough, use SP4904 024 (Image Quality Exposure: Thin Line – Generation Mode). Normally, SP4904 024 is set to 0 (OFF). As the setting is increased (1~3) the line width correction effect becomes stronger, and lines become thinner. All settings of SP4903 092 will be affected by the same amount.

Settings Adjustable for Each Original Mode

Independent Dot Erase

Item	Range	Default	SP No.
Text	0~14	8	SP4903 060
Photo		0	SP4903 061
Text/Photo		0	SP4903 062
Pale		0	SP4903 063
Generation Copy		8	SP4903 064

Independent dot erase removes isolated black pixels. As this setting is increased, the greater the number of eliminated isolated pixels. Setting to zero switches this function off.

Background Erase

Item	Range	Default	SP No.
Text	0~255	0 (Off)	SP4903 070
Photo			SP4903 071
Text/Photo			SP4903 072
Pale			SP4903 073
Generation Copy			SP4903 074

Background erase attempts to eliminate the heavy background texture from copies of newspaper print or documents printed on coarse paper. Pixels of density below the selected threshold level are eliminated. Setting this feature to zero switches it off. Increasing this setting increases the effect of background erase.

2.3.6 RELATION BETWEEN THE SP AND UP SETTINGS

The tables below illustrate the relationship between the UP and SP settings for each of the 5 original modes. The scale across the top of the table is the range of settings for the SP modes.

The settings in the gray areas indicate the UP settings overlaid on the SP scale of the table. Words that are not shaded within the tables, such as 'softer', indicate how the image changes if you change the SP setting in a certain direction. The related UP mode is User Tools> Copier Features> General Features> Copy Quality.

Text Mode

Setting	0	1	2	3	4	5	6	7	8	9	10	SP No.
25% ~55%		Soft				Normal				Sharp		SP4903 001
55.5 ~ 75%									SP4903 002			
75.5 ~ 160%									SP4903 003			
160.5 ~ 400%									SP4903 004			

Photo Mode (Dithering)

Setting	0	1	2	3	4	5	6	SP No.
25% ~55%	Softer			Print Photo		Sharper		SP4903 005
55.5 ~ 75%							SP4903 006	
75.5 ~ 160%							SP4903 007	
160.5 ~ 400%							SP4903 008	

Photo Mode (Error Diffusion)

Setting	0	1	2	3	4	5	6	SP No.
25% ~55%	Softer	Normal				Glossy Photo	Sharper	SP4903 009
55.5 ~ 75%								SP4903 010
75.5 ~ 160%								SP4903 011
160.5 ~ 400%								SP4903 012

Text/Photo Mode

Setting	0	1	2	3	4	5	6	7	8	9	10	SP No.	
25% ~55%		Photo Priority				Normal				Text Priority		SP4903 013	
55.5 ~ 75%													SP4903 014
75.5 ~ 160%													SP4903 015
160.5 ~ 400%													SP4903 016

Pale Mode

Setting	0	1	2	3	4	5	6	7	8	9	10	SP No.
25% ~55%		Soft				Normal				Sharp		SP4903 017
55.5 ~ 75%												SP4903 018
75.5 ~ 160%												SP4903 019
160.5 ~ 400%												SP4903 020

Generation Copy

Setting	0	1	2	3	4	5	6	7	8	9	10	SP No.
25% ~55%		Soft				Normal				Sharp		SP4903 021
55.5 ~ 75%												SP4903 022
75.5 ~ 160%												SP4903 023
160.5 ~ 400%												SP4903 024

Background Color Dropout

SP NO.	MODE NAME	TARGETTED COLOR	VALUES
4901 020	Background Dropout – Weak	Orange	165 ~ 255 (Default: 180)
4901 021	Background Dropout – Medium	Green	115 ~164 (Default: 155)
4901 022	Background Dropout - Strong	Blue	15 ~ 144 (Default: 105)

2.4 LASER EXPOSURE

2.4.1 OVERVIEW

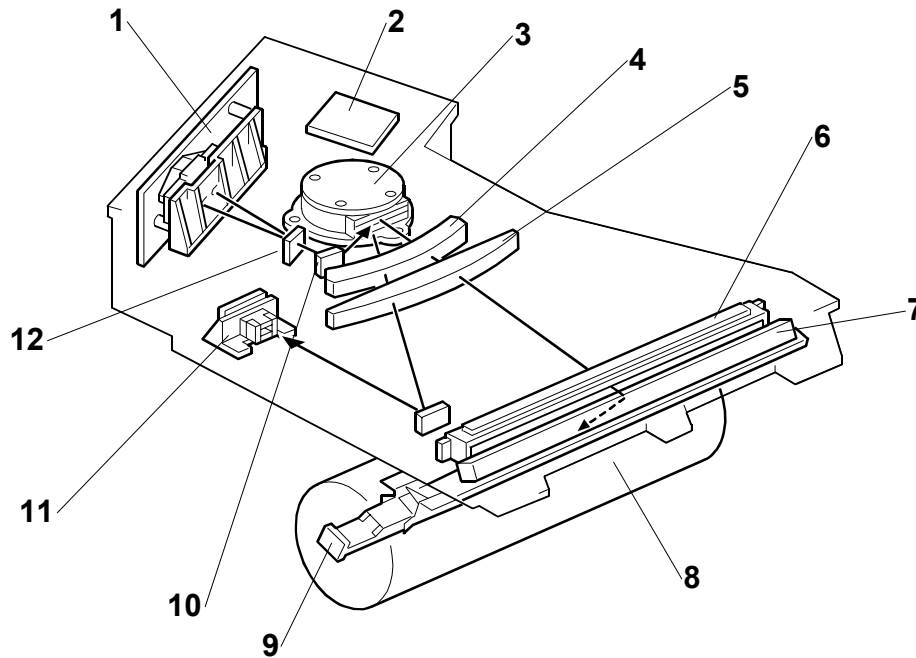

- | | |
|---------------------------------------|------------------------------------|
| 1. LD Unit | 7. 2nd Mirror |
| 2. Polygon Mirror Motor Control Board | 8. Drum |
| 3. Polygon Mirror Motor | 9. Toner Shield Glass |
| 4. F-Theta Lens 1 | 10. 1st Mirror |
| 5. F-Theta Lens 2 | 11. Laser Synchronization Detector |
| 6. BTL Lens | 12. Cylindrical Lens |

2.4.2 LASER EXPOSURE MECHANISM

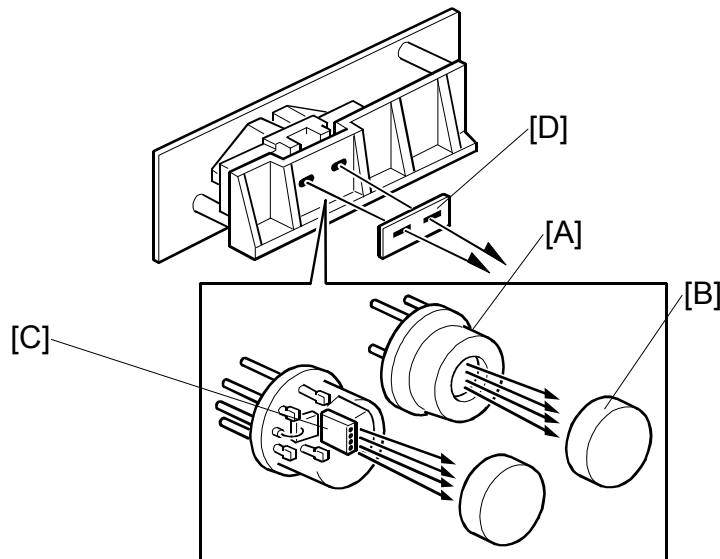

The LD unit consists of two 4-channel LDA's (Laser Diode Arrays) and two collimating lenses.

Each LDA produces 4 beams [A]. Each collimating lens [B] is a fixed lens, seated in a V-groove and held in place by a spring and a screw.

Four beams from each LDA [C] pass through the collimating lenses, through the apertures [D], then strike the polygonal mirror. Due to this multi-beam writing, the polygonal mirror motor speed can be reduced, thus the noise generated by the polygon mirror motor and the wear on the motor can be reduced.

Auto Power Control (APC)

A built-in photo diode detects the light emitted from the LD unit. When the photo diode detects this light, it generates a signal and the feedback of this signal to the LD control board is used to adjust the strength and amount of light in the laser beams.

NOTE: The laser diode array is assembled and adjusted in the factory, and does not require physical position adjustment in the field.

LD drivers control the power output from the laser diodes.

( Digital Processes > Printing > Laser Printing > **Laser Diode Power Control**)

NOTE: The reference levels are adjusted on the production line. Never touch the variable resistors on the LD unit.

2.4.3 LD SAFETY SWITCHES

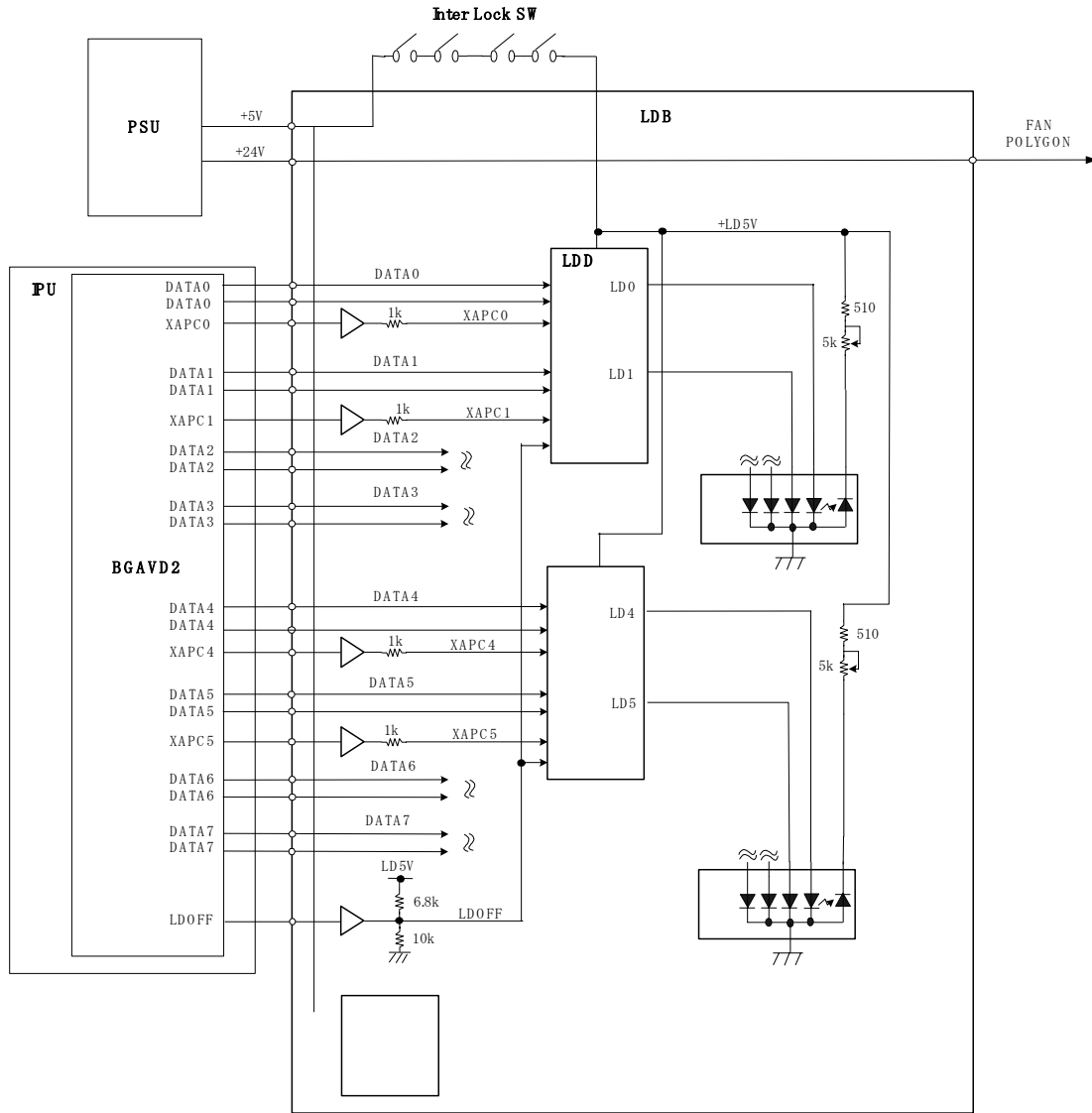

To ensure technician and user safety and to prevent the laser beam from inadvertently switching on during servicing, there are four safety switches inside the front cover (these are the 4th front left and 4th front right door safety switches).

When one of the front covers is open, the 5 V line connecting to the LD drivers (LDD) is disconnected.

2.4.4 MULTI-BEAM LINE EXPOSURE

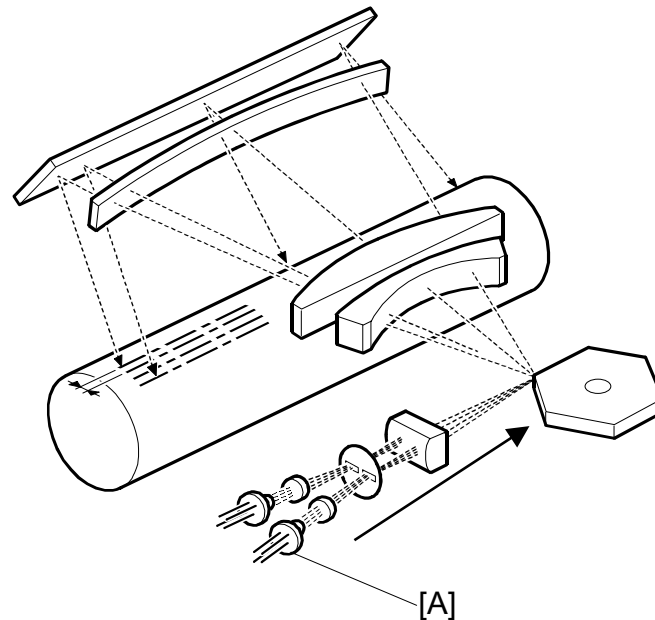

The LD unit contains two laser diode arrays (LDA) [A], each with one 4-channel array, allowing the LD unit to produce a total of eight beams. This multi-beam exposure mechanism has the following advantages:

- Reduces the number of rotations required of the polygon mirror motor.
- Reduces the amount of noise generated by the polygon mirror motor because it is rotating at lower speed.
- Reduces the need for LD unit replacement.
- Allows production of a more precision beam on a stable platform.

The laser synchronization detector detects only Channel 0 and Channel 1, the uppermost beams of each parallel array.

The main scan pitch of Channels 2 to 7 is determined by setting SP2115 001~006 (Main Scan Beam Pitch Adjustment) at the factory. For this reason, when the LD unit is replaced, these SP codes must be input for the new unit. The correct SP settings are printed on a label attached to the LD unit.

An SC code is issued for a laser synchronization detector error if the LD unit malfunctions and does not emit the laser beams.

2.4.5 POLYGON MIRROR MOTOR

The polygon mirror reflects the laser beam onto the OPC drum to expose the image line by line in the main scan direction. The polygon mirror motor rotates at a constant speed, even while the copier is in standby mode, but shuts off when the copier enters the energy conservation mode.

The polygon mirror motor has no brake mechanism, so it requires about 3 minutes to stop rotating. Before moving the machine or before servicing the motor or the area around the polygon mirror motor, you should switch off the copier main power switch, disconnect the machine, and wait at least three minutes for the motor to stop rotating.

NOTE: The polygon mirror motor requires about 10 seconds to reach full speed after the machine awakes from the energy conservation mode, or after the machine is switched from the normal mode to low speed mode for printing on thick paper. The machine cannot print during this 10 second interval until it reaches full rotation speed.

2.4.6 1200-DPI RESOLUTION

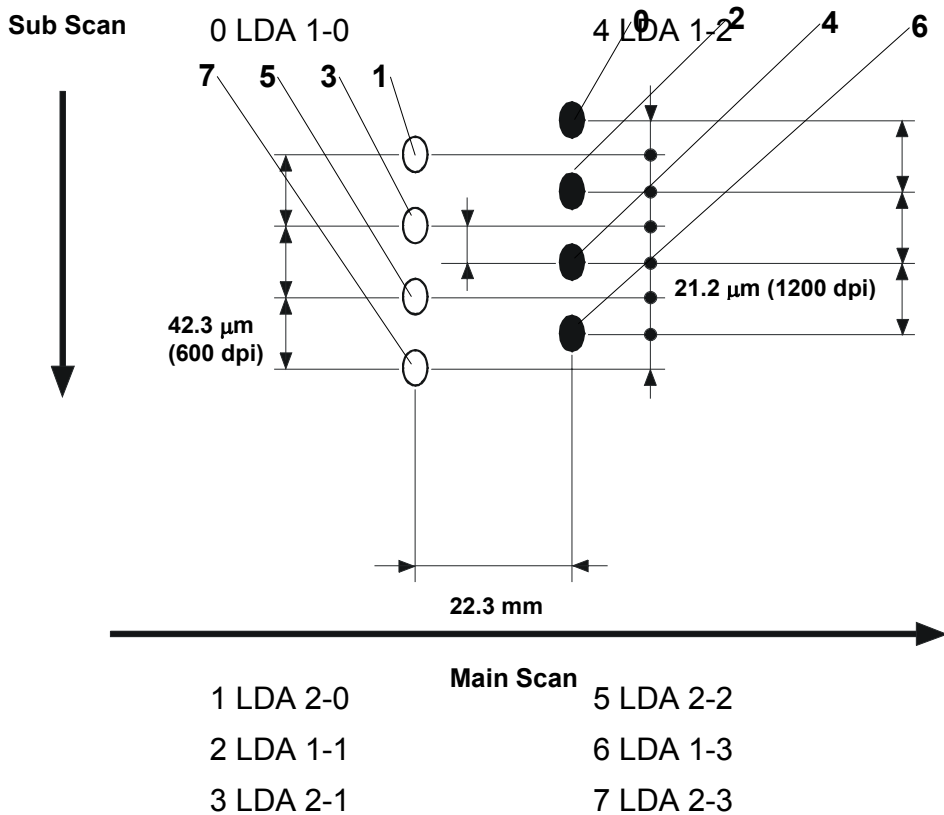

The original is scanned at 600 dpi, then the 600 dpi output is boosted to 1200 dpi 1-bit data during image processing in the IPU.

This machine can produce an image at 1200 dpi by writing each dot twice, possibly with two different values, depending on the results of image processing. This is achieved with the LD unit, which has two laser diode arrays, each with 4 channels which together produce 8 beams. As shown in the illustration above, the beams from each laser diode are emitted in two parallel lines.

For copying, 1200 dpi is used. For printing, the default is 600 dpi, but 1200 dpi can be selected.

The diagram shows how the two sets of four beams are interlaced to produce a sub scan resolution of 1200 dpi.

There are two parallel rows of four beams, separated by 22.3 mm in the main scan direction. In each of these rows, the beams are spaced at 42.3 micrometer intervals (this is the same as 600 dpi).

The rows are also offset in the sub scan direction by 21.2 micrometers.

The net result is that we have dots at 21.2 micrometer intervals, which is the same as 1200 dpi

2.4.7 OPTICAL PATH

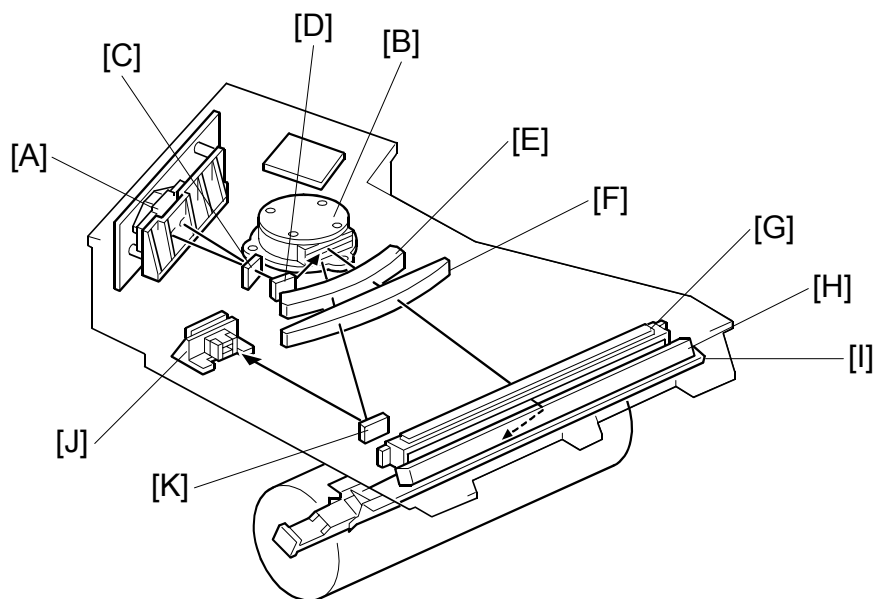

The output path from the laser diode to the drum is shown above.

The LD unit [A] outputs eight laser beams to the polygonal mirror [B] (six mirror surfaces) through the cylindrical lens [C] and the 1st mirror [D].

Each surface of the polygon mirror reflects eight full main scan lines. The laser beams go to the F-theta lens 1 [E], F-theta lens 2 [F], BTL (barrel toroidal lens) [G], and mirror [H]. Then these laser beams go to the drum through the toner shield glass [I].

The laser synchronizing detector [J] determines the main scan starting position. This sensor sends a synchronization signal when the laser synchronizing detector mirror [K] reflects the laser beam to the detector as the laser beam starts its sweep across the drum.

The laser synchronizing detector detects only the beams emitted from Channels 1 and 0, the uppermost beams of each parallel array.

2.5 DRUM UNIT

2.5.1 PROCESS CONTROL

Drum potential gradually changes for the following reasons:

- Dirty optics, exposure glass
- Dirty charge corona casing, grid plate
- Deterioration of drum sensitivity

What Happens at Power On

Here is a description of what happens while the fusing temperature is below 100°C immediately after the main power switch is switched on (process control must also be enabled with SP3901 001, or this will not happen).

At any time, this process can also be executed manually by using SP2962. However, process control must be enabled with SP3901 001 and the fusing temperature must be below 100°C, or this will not work.

1. Drum potential sensor is calibrated.
2. Drum starts first rotation after fusing temperature reaches 100°C.
3. ID sensor is calibrated (Vsg).
4. Readout from the drum potential sensor is used to adjust:
 - Grid voltage (Vg)
 - Laser diode (LD) power.

NOTE: This step occurs only if process control is enabled with SP3901 001 (Auto Process Control On/Off Setting). If this SP is disabled, then:

 - Development bias is set to the value stored in SP2201 1
 - Grid voltage is set to the value stored in SP2001 1
 - Laser power is set to the values stored in SP2103
5. TD sensor is calibrated (Vref).

Any SC codes that are generated during auto process control are logged in the memory and do not appear. The machine will continue to operate.

2.5.2 DRUM UNIT COMPONENTS

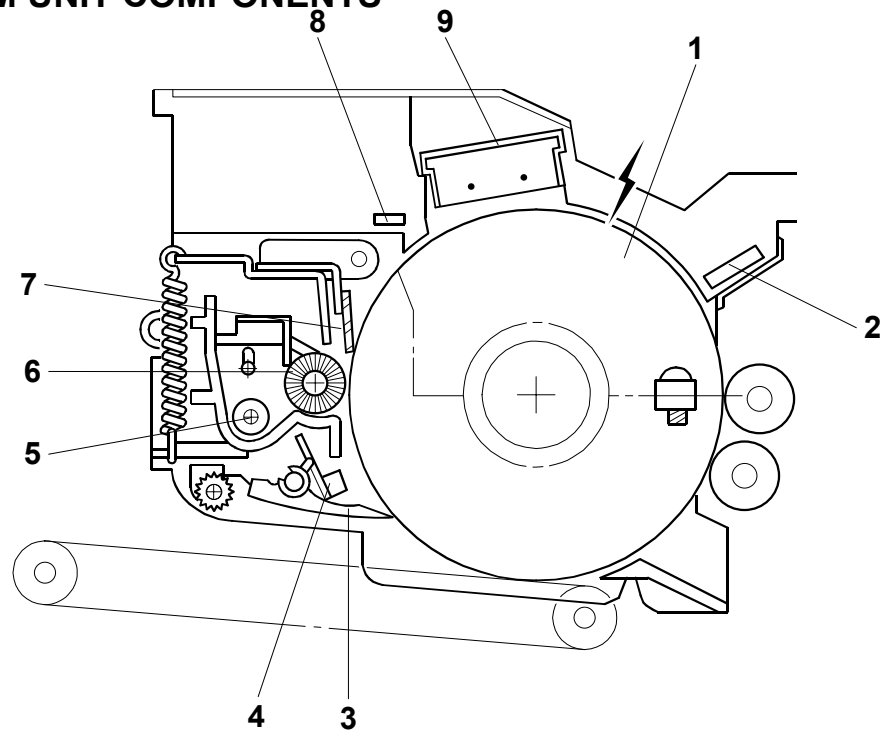

The drum unit consists of the components shown in the above illustration. An organic photoconductor drum (diameter: 100 mm) is used for this model.

- | | |
|--------------------------|-----------------------|
| 1. OPC Drum | 6. Cleaning Brush |
| 2. Drum Potential Sensor | 7. Cleaning Blade |
| 3. Pick-off Pawl | 8. Quenching Lamp |
| 4. Image Density Sensor | 9. Charge Corona Unit |
| 5. Toner Collection Coil | |

2.5.3 DRUM DRIVE

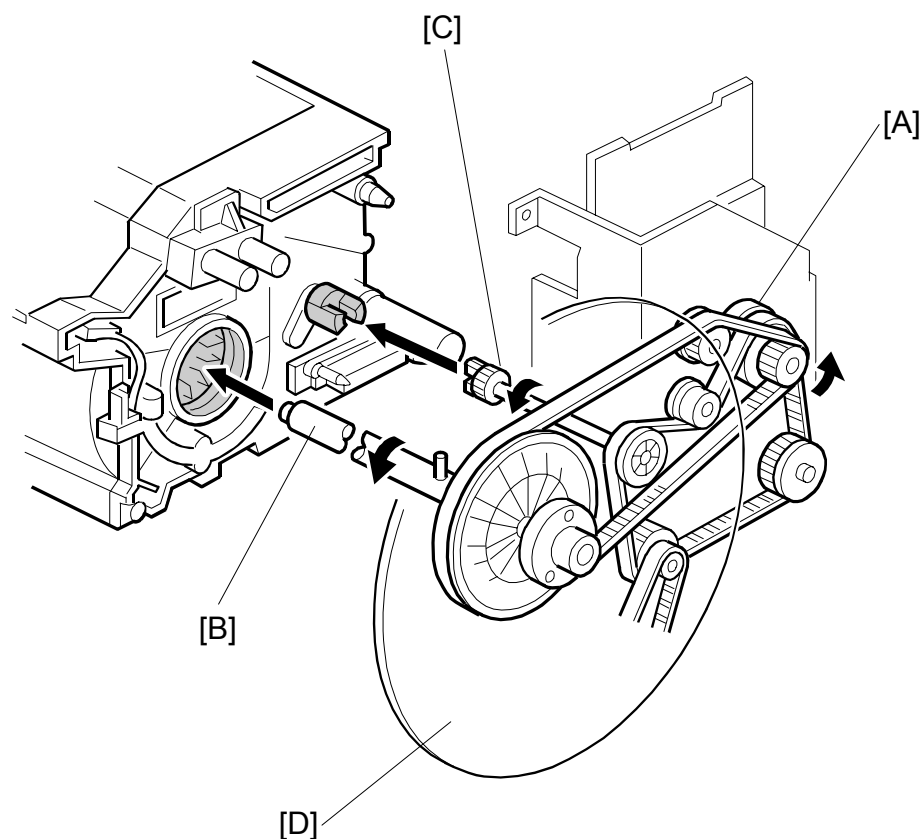

The drive from the drum motor [A] is transmitted to the drum and the cleaning unit through timing belts, gears, the drum drive shaft [B], and the cleaning unit coupling [C].

The drum motor has a drive controller, which outputs a motor lock signal when the rotation speed is out of the specified range. The drum speed for the B070 (90 cpm) is 450 mm/s and for the B071 (105 cpm) 500 mm/s.

The flywheel [D] on the end of the drum drive shaft stabilizes the rotation speed.

2.5.4 DRUM CHARGE

Overview

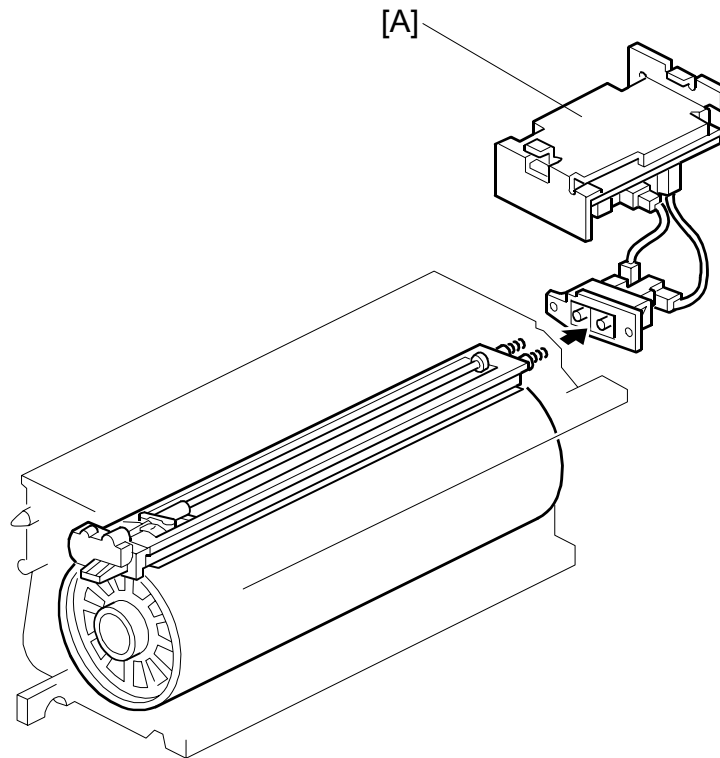

This copier uses a double corona wire Scorotron system to charge the drum. Because of the high speed of this copier, two corona wires are needed to give a sufficient, uniform negative charge to the drum surface. The stainless steel grid plate makes the corona charge uniform and controls the amount of negative charge on the drum surface by applying a negative voltage to the grid.

The CBG (Charge, Bias, Grid) power pack [A] supplies a constant corona current to the corona wires, $-1600 \mu\text{A}$ for Photo mode and $-1400 \mu\text{A}$ for all other modes (Text, Text/Photo, Pale, Generation Copy).

The voltage to the grid plate is automatically controlled to maintain the correct image density in response to changes in drum potential caused by dirt on the grid plate and charge corona casing. This is described in Process Control section in more detail.

Charge Corona Wire Cleaning

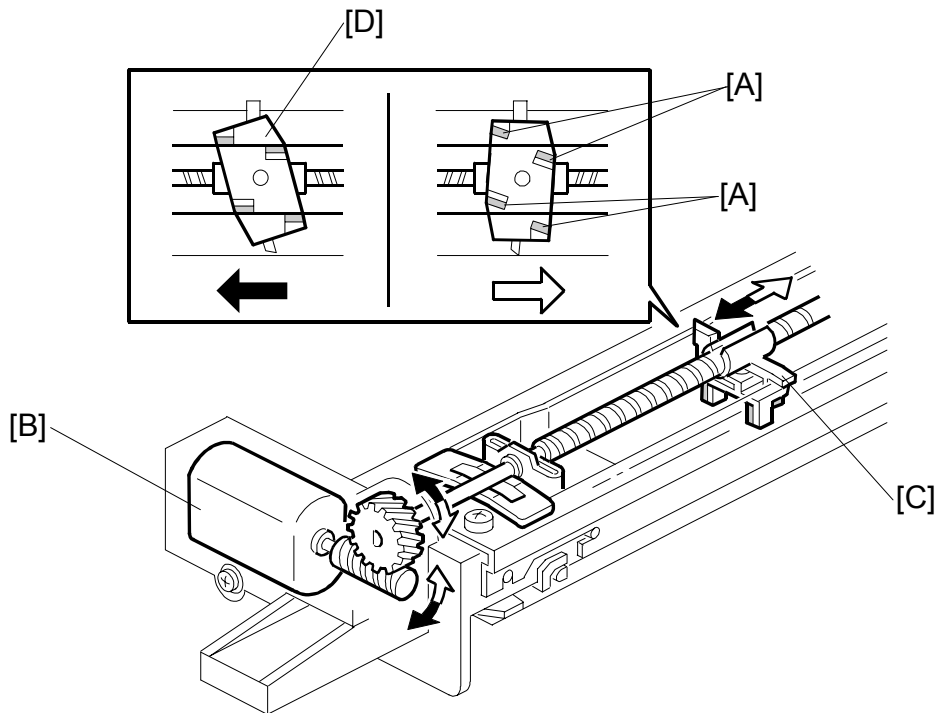

Air flowing around the charge corona wire may deposit toner particles on the corona wires. These particles may interfere with charging and cause low density bands on copies.

The wire cleaner pads [A] automatically clean the wires to prevent such a problem.

The wire cleaner is driven by a dc motor [B]. Normally the wire cleaner [C] is at the front end (the home position). Just after the main switch is turned on, the wire cleaner motor turns on to bring the wire cleaner to the rear and then back to the home position. When the wire cleaner [D] moves from the rear to the home position, the wire cleaner pads swivel, bringing the pads into contact with the wires, and clean the wires as it moves forward.

Cleaning is executed when:

- The machine is switched on and the fusing temperature is less than 100°C while auto process control executes.
- Every 24 hours.
- After every 5,000 copies. This can be adjusted with SP2804 002 (Charge Corona Cleaner Setting – Corona Wire Cleaning Interval).

2.5.5 DRUM CLEANING

Overview

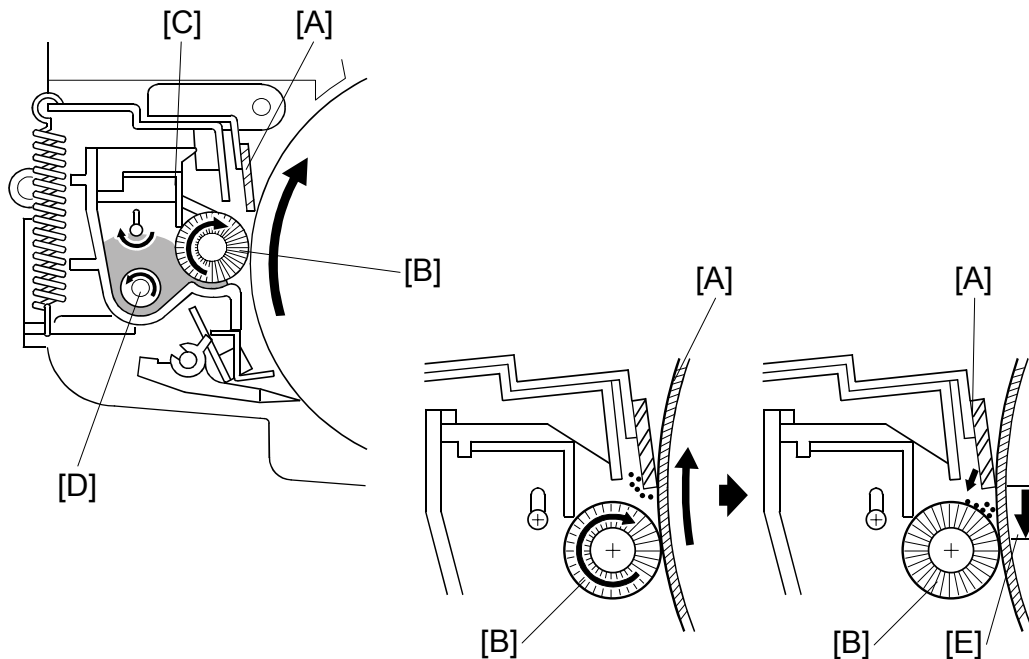

This copier uses a counter blade system to clean the drum. In a counter blade system, the drum cleaning blade [A] is angled against drum rotation. The counter blade system has the following advantages:

- Less wearing of the cleaning blade edge
- High cleaning efficiency

Due to the high efficiency of this cleaning system, the pre-cleaning corona and cleaning bias are not used for this copier.

The cleaning brush [B] helps the cleaning blade. The brush removes toner from the drum surface and any remaining toner is scraped off by the cleaning blade. Toner on the cleaning brush is scraped off by the mylar [C] and falls onto the toner collection coil [D]. The coil transports the toner to back to the toner entrance tank in the toner bank unit for recycling.

To remove any accumulated toner at the edge of the cleaning blade, the drum turns in reverse for about 40 ms [E] at the end of every copy job. This is also during long copy jobs every 30 min. For details, refer to SP2506 002 (Cleaning Interval – Multiple Copy - Interval) in Section “5. Service Tables”.

The accumulated toner is deposited on the drum and is removed by the cleaning brush.

2.5.6 CLEANING UNIT DRIVE

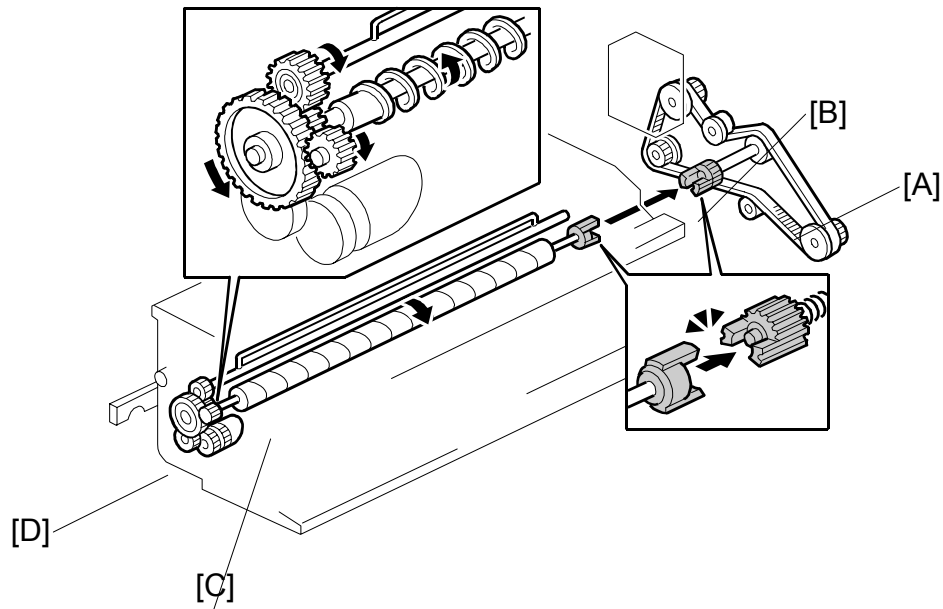

Drive from the drum motor is transmitted to the cleaning unit drive gear via the timing belt [A] and the cleaning unit coupling [B]. This coupling drives the cleaning brush [C] directly. The cleaning brush then transmits the drive to the gear at the front, which drives the toner collection coil gear [D].

Cleaning Blade Pressure and Side-to-Side Movement

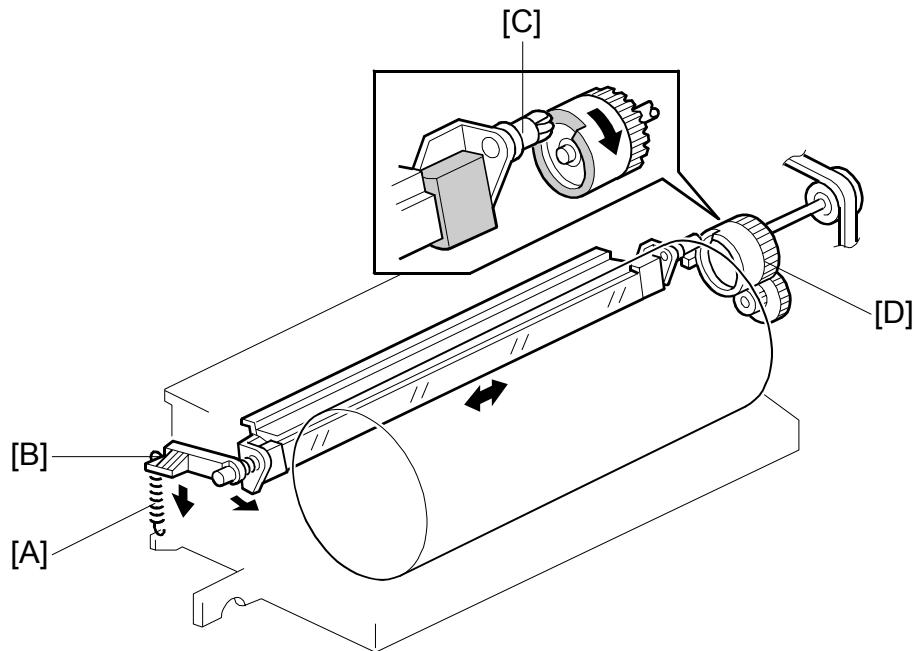

The spring [A] always pushes the cleaning blade against the drum. The cleaning blade pressure can be manually released by pushing up the release lever [B]. To prevent cleaning blade deformation during transportation, the release lever must be locked in the pressure release (upper) position.

The guide roller [C] at the rear end of the cleaning blade holder touches the cam gear [D], which moves the blade from side to side. This movement helps to disperse accumulated toner to prevent early blade edge wear.

2.5.7 OTHERS

Air Flow Around the Drum

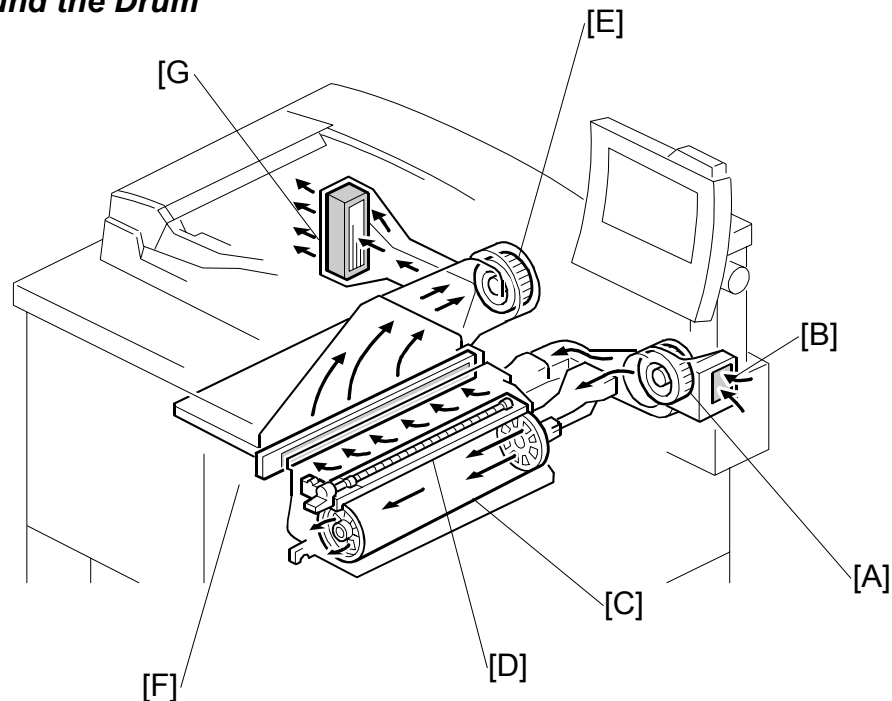

The drum cooling fan [A] draws cool air through the filter [B] and sends it to the center of the drum [C], then over the charge corona unit [D].

Holes in the flanges on both ends of the drum allow air to pass through the drum to cool it. After the air has passed through the center of the drum, the exhaust fan [E] draws the air out of the interior of the machine, through the toner filter [F] to remove free floating toner, through the ozone filter [G] to remove ozone, then finally out of the machine.

To keep the temperature inside the machine constant, the drum cooling fan turns slowly during standby, but turns faster during copying.

NOTE: This ozone filter does not require replacement.

Drum Pick-off Pawls

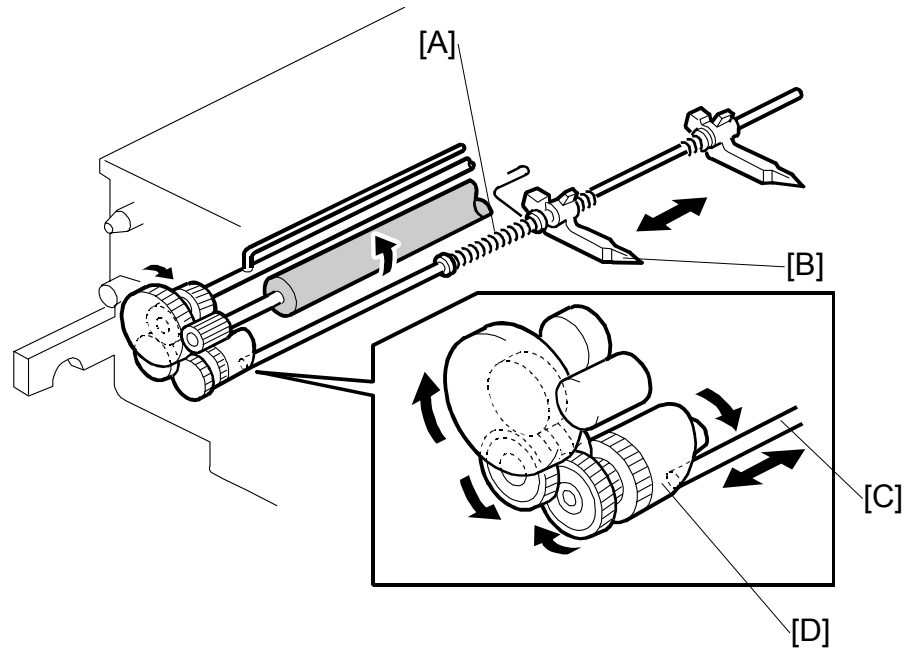

If the paper does not separate from the drum after image transfer, the drum pick-off pawls strip the paper from the drum.

Pressure from small springs [A] press the pick-off pawls [B] against the surface of the drum.

The shaft [C] and the cam [D] move the pick-off pawls from side to side to ensure that they never remain at the same location (this prevents wear on the drum).

Drum Quenching

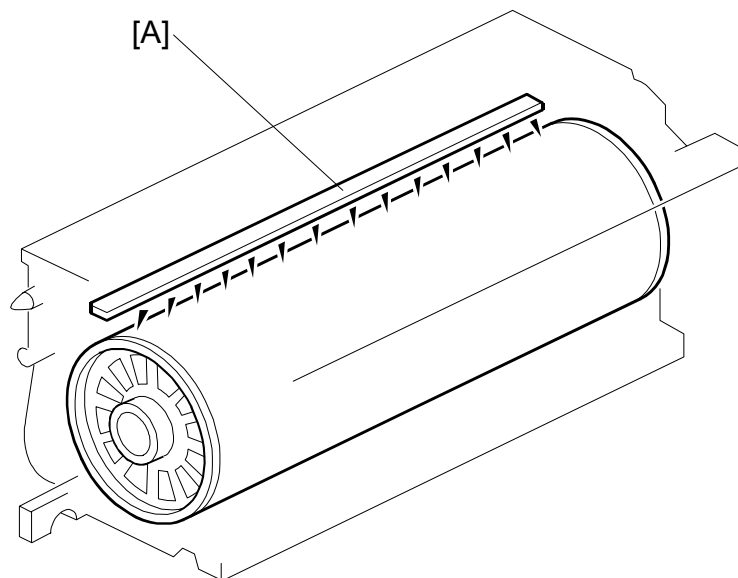

In preparation for the next copy cycle, light from the quenching lamp [A] neutralizes any charge remaining on the drum.

The quenching lamp consists of an array of 16 red LEDs extending across the full width of the drum.

2.6 DEVELOPMENT

2.6.1 OVERVIEW

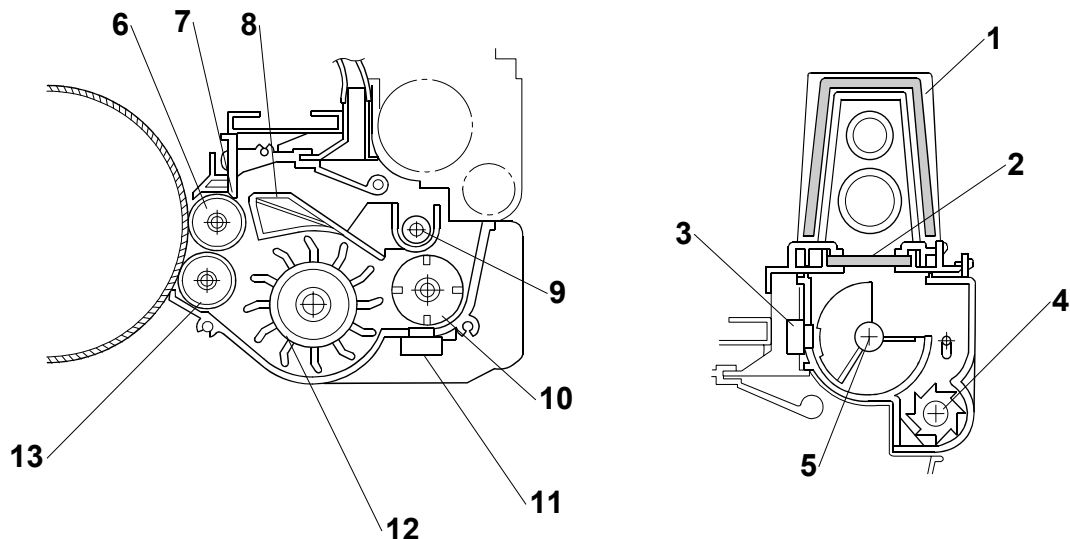

- | | |
|-----------------------------|------------------------------|
| 1. Hopper Filter | 8. Separator |
| 2. Hopper Center Filter | 9. Toner Transport Coil |
| 3. Toner Hopper Sensor | 10. Development Agitator |
| 4. Agitator | 11. TD Sensor |
| 5. Toner Supply Roller | 12. Paddle Roller |
| 6. Upper Development Roller | 13. Lower Development Roller |
| 7. Doctor Blade | |

This copier uses a double roller development system and a dual component development process with toner particles $6.8 \mu\text{m}$ and developer particles $50 \mu\text{m}$. To improve image quality, the width of the magnetic area on the lower development roller has been reduced.

This system differs from single roller development systems in that:

- It develops the image in a narrower area
- It develops the image twice
- The relative speed of each development roller against the drum is reduced.

This machine contains a toner recycling system. Toner recycled from the drum cleaning unit is transferred to the toner hopper with fresh toner, where they are mixed by the toner agitator. The mechanism is explained in the Toner Supply and Recycling section.

2.6.2 DEVELOPMENT MECHANISM

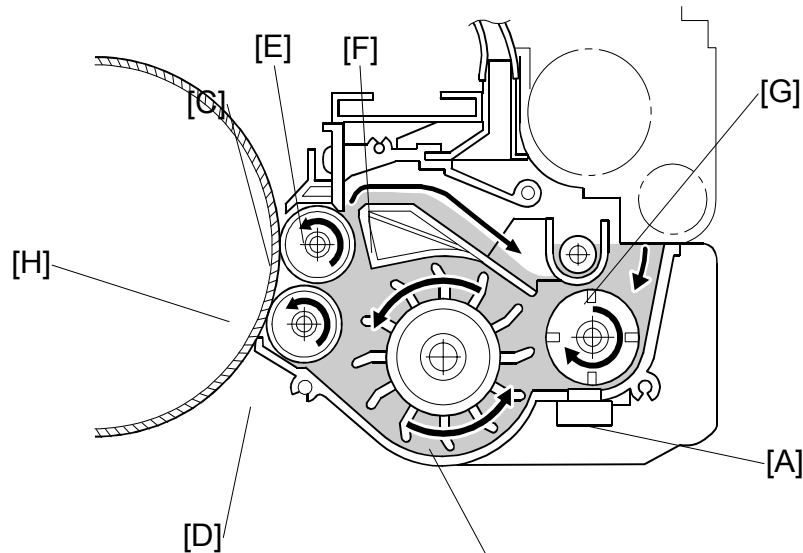

Toner and developer are mixed in the toner agitator by the cross-mixing roller [A]. The paddle roller [B] picks up the developer and sends it to the upper development roller [C]. Internal permanent magnets in the development rollers attract the developer to the development roller sleeve. Developer from the upper development roller sleeve is also attracted to the lower development roller [D].

The upper development roller carries the developer past the doctor blade [E] which trims the developer to the desired thickness. Backspill (excess toner) spills over the separator [F] to the toner transport coil [G] which sends the developer from back to front to the cross-mixing roller.

In this machine, black areas of the latent image are at a low negative charge (about -150 V) and white areas are at a high negative charge (about -800 V).

The development roller is given a negative bias to attract negatively charged toner to the black areas of the latent image on the drum.

The development rollers continue to turn, carrying the developer to the drum [H]. When the developer brush contacts the drum surface, the low-negatively charged areas of the drum surface attract and hold the negatively charged toner. In this way, the latent image is developed.

2.6.3 DRIVE

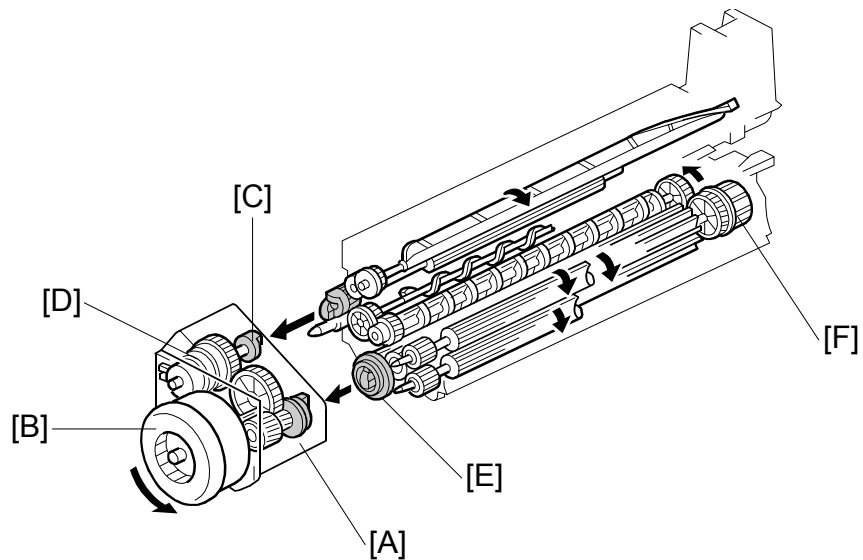

The gears in the development unit are driven by the development drive gear [A] when the development motor [B] (a dc servomotor) turns.

The gears in the toner hopper are driven by the toner supply roller drive gear [C] when the toner supply roller clutch [D] activates.

A one-way clutch on the paddle roller knob [F] prevents counter-clockwise rotation of the paddle roller.

2.6.4 CROSSMIXING

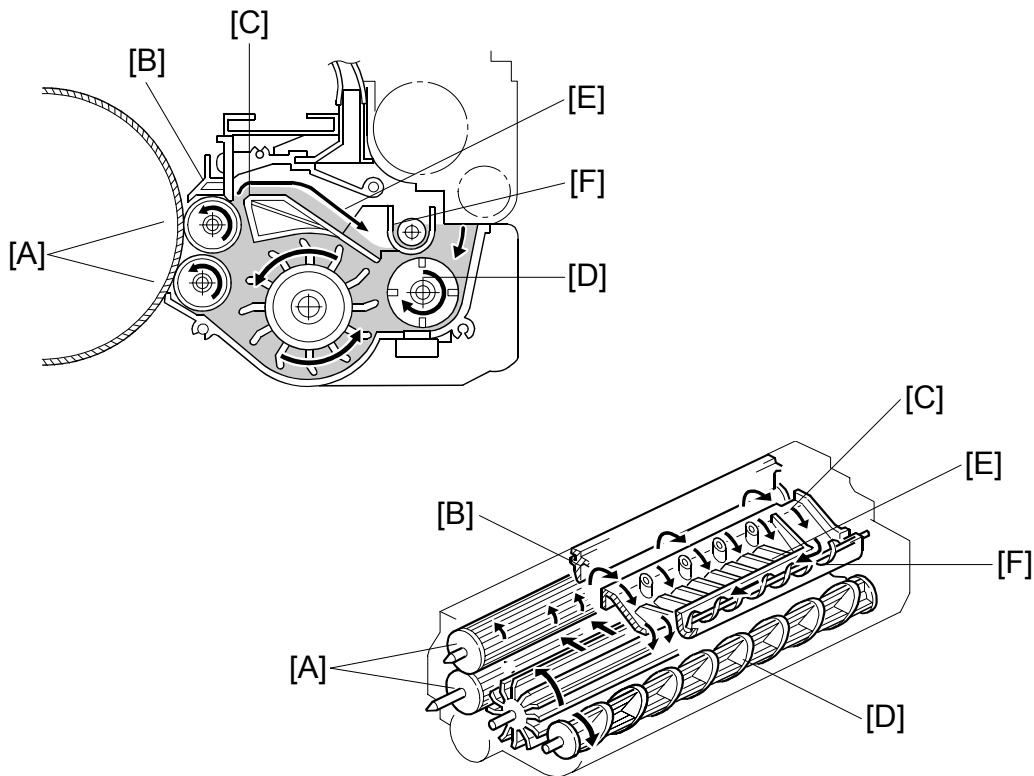

This copier uses a standard cross-mixing mechanism to keep the toner and developer evenly mixed. It also helps agitate the developer to prevent developer clumps from forming and helps create the triboelectric charge.

The developer on the turning development rollers [A] is split into two parts by the doctor blade [B]. The part that stays on the development rollers forms the magnetic brush and develops the latent image on the drum. The part that is trimmed off by the doctor blade goes to the backspill plate [C].

As the developer slides down the backspill plate to the agitator [D], the mixing vanes [E] move it slightly toward the rear of the unit. Part of the developer falls into the auger inlet and is transported to the front of the unit by the auger [F].

2.6.5 DEVELOPMENT BIAS

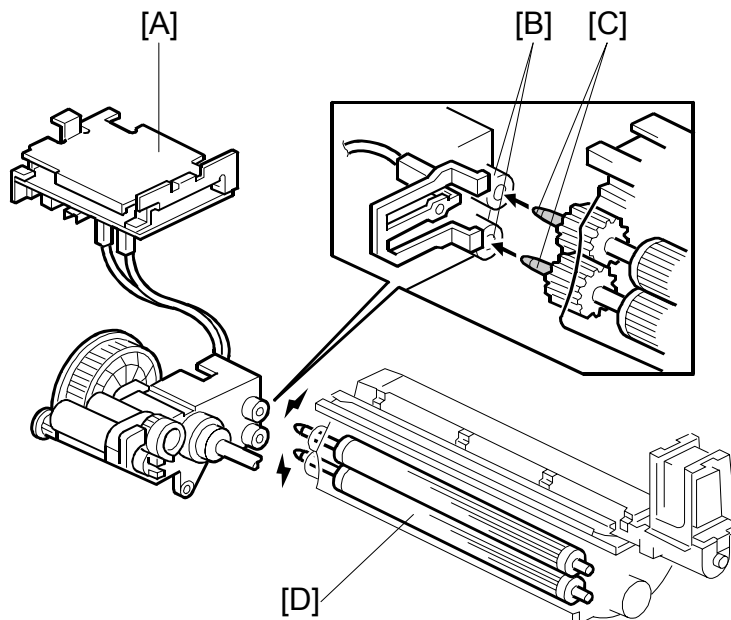

The CBG (Charge Bias Grid) power pack [A] applies the negative development bias (-550V) to both the lower sleeve roller and upper sleeve roller through the receptacles [B] and the sleeve roller shafts [C].

The development bias prevents toner from being attracted to the non-image areas on the drum where there is residual voltage. In addition, the development bias changes with the image density setting chosen for the copy job by the user.

The development rollers [D] employ fixed shafts that do not rotate. This eliminates friction on the shafts so they never require lubrication.

2.7 TONER SUPPLY AND RECYCLING

2.7.1 OVERVIEW

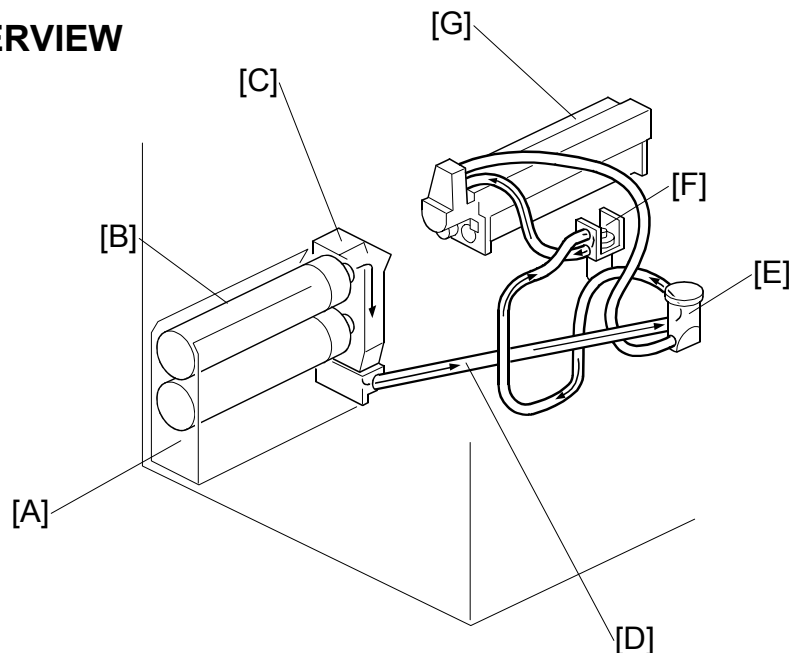

Toner is supplied from a toner bank [A] on the left side of the machine and separated from the development unit. The toner bank holds two bottles, but only one bottle operates at a time.

A toner bottle motor turns the bottle [B], causing toner to leave the bottle and drop into the toner entrance tank [C].

The toner transport coil in the toner transport tube [D] transports toner to the toner supply cylinder [E]. Due to the length of the toner supply path, a toner supply pump [F] is needed to draw the toner into the toner hopper [G].

Here are some important points to remember about the toner bank:

- The toner bank holds two toner bottles. This doubles the toner supply capacity for the machine and allows replacement of an empty toner bottle while the machine is operating.
- The machine works even if there is only one bottle installed.
- Toner can be supplied from either the upper or lower toner bottle, but not from both at the same time. When toner runs out in one bottle, toner supply from the other bottle starts automatically.
- After the toner near-end message is displayed for both toner bottles, the toner bottle still has enough toner for about 200 copies.
- Load the lower toner bottle first, then the upper toner bottle. If the upper toner bottle is loaded first, a message will be displayed on the operation panel to request loading the lower toner bottle.
- Handle the toner bottles carefully to avoid shaking them.

2.7.2 TONER BANK

Toner Bottle Switching Mechanism

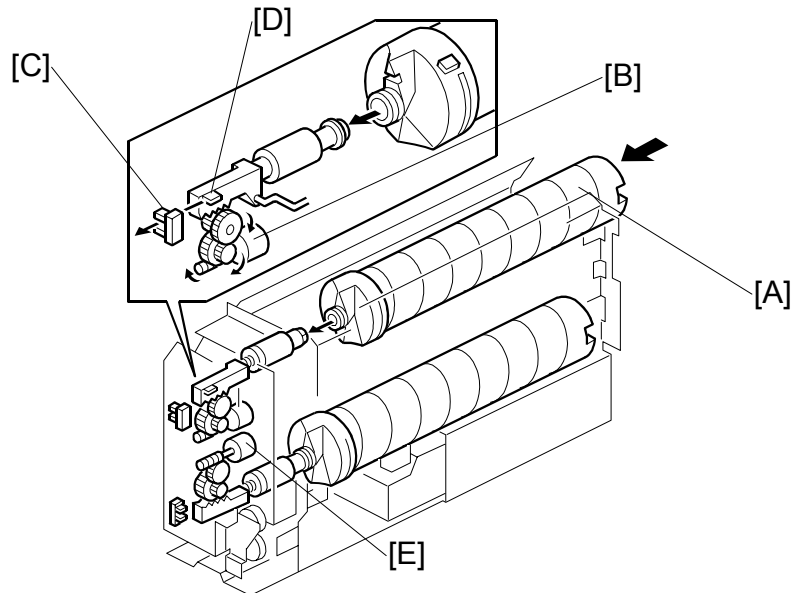

When the upper toner bottle [A] is supplying toner, the upper bottle cap motor [B] pulls out the toner bottle cap. The upper bottle cap sensor [C] detects the actuator [D] of the toner bottle opening rod, then the motor shuts off to close the cap again.

Toner is supplied from the toner bottle to the toner entrance tank where a toner near end sensor (see the next page) checks for the presence of toner in the toner entrance tank.

When the toner near-end sensor (not shown) can no longer detect any toner, it signals the machine that it is time to switch bottles. The upper bottle cap motor switches on and closes the cap of the top bottle, while the lower bottle cap motor [E] switches on and opens the cap of the lower bottle so it can start supplying toner.

Toner Near-end, Toner End, Bottle Replacement

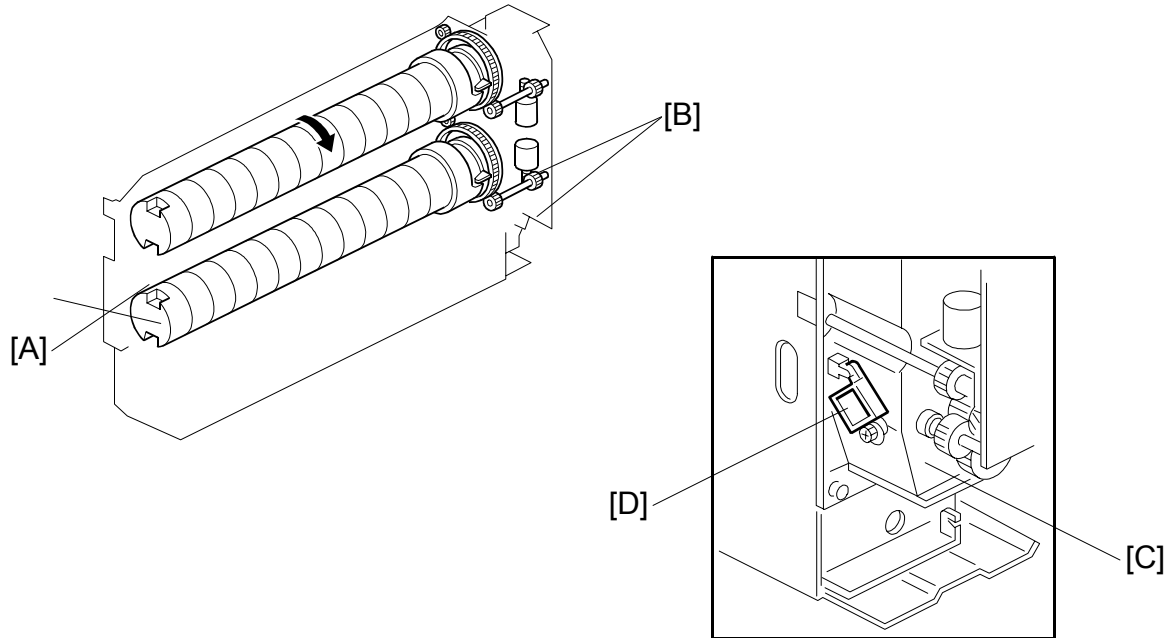

Each toner bottle [A] has an independent toner bottle motor [B]. An empty toner bottle can be replaced during printing.

The toner near-end sensor detects toner as it falls from the toner bottle into the toner entrance tank [C]. If the toner near end sensor [D] detects that no toner has come out of the toner bottle, the toner bottle enters the toner near-end condition.

The toner bottle motor then rotates the toner bottle up to 20 times to try to supply toner to the toner entrance tank. If the sensor detects toner more than 5 times, the near-end condition is cleared. However, if the toner near end sensor fails to detect toner 5 consecutive times, 200 more copies can be made from that bottle, then the machine declares it to be empty.

When the bottle is empty, the machine switches to the second toner bottle. The first toner bottle cap motor closes the bottle cap and the second toner bottle cap motor pulls out the second bottle cap. The motors operate until the first bottle inner cap sensor does not detect the actuator and the second bottle inner cap sensor does detect the actuator.

The second toner bottle is then rotated up to 15 times. If the near-end sensor detects toner after 5 times, the machine can print from that bottle.

Meanwhile, the machine indicates that the first bottle is empty. When the user takes out the old bottle, and puts in a new one, this is detected by the toner bottle sensor. (☛"Toner Bottle Sensors",2-57) However, this bottle is not tested until the second bottle is empty.

NOTE: If an empty bottle is not replaced, and the other bottle becomes empty (no toner detected 10 consecutive times, as described above), 200 more copies can be made. Then the machine enters the system toner end condition (both bottles are empty), and this is indicated in the operation panel display.

When the second bottle is empty, the machine switches back to the first bottle.

The first bottle is tested now, by rotating it 15 times as usual. If this bottle is also found to be empty, the machine enters the system toner end condition. This time, the machine cannot print until one of the toner bottle sensors detects that a new toner bottle has been inserted (the machine does not allow the 200 extra copies).

When both bottles are empty and a new toner bottle is placed in the toner bank, the new toner bottle is rotated 15 times to supply toner to the toner entrance tank. If the toner near end sensor then detects toner in the toner entrance tank, the system toner end condition is cleared. If the toner near end sensor detects there is still no toner in the toner entrance tank, the bottle cap motor closes the toner bottle cap. The system toner end condition continues and printing is not possible.

Toner Bottle Sensors

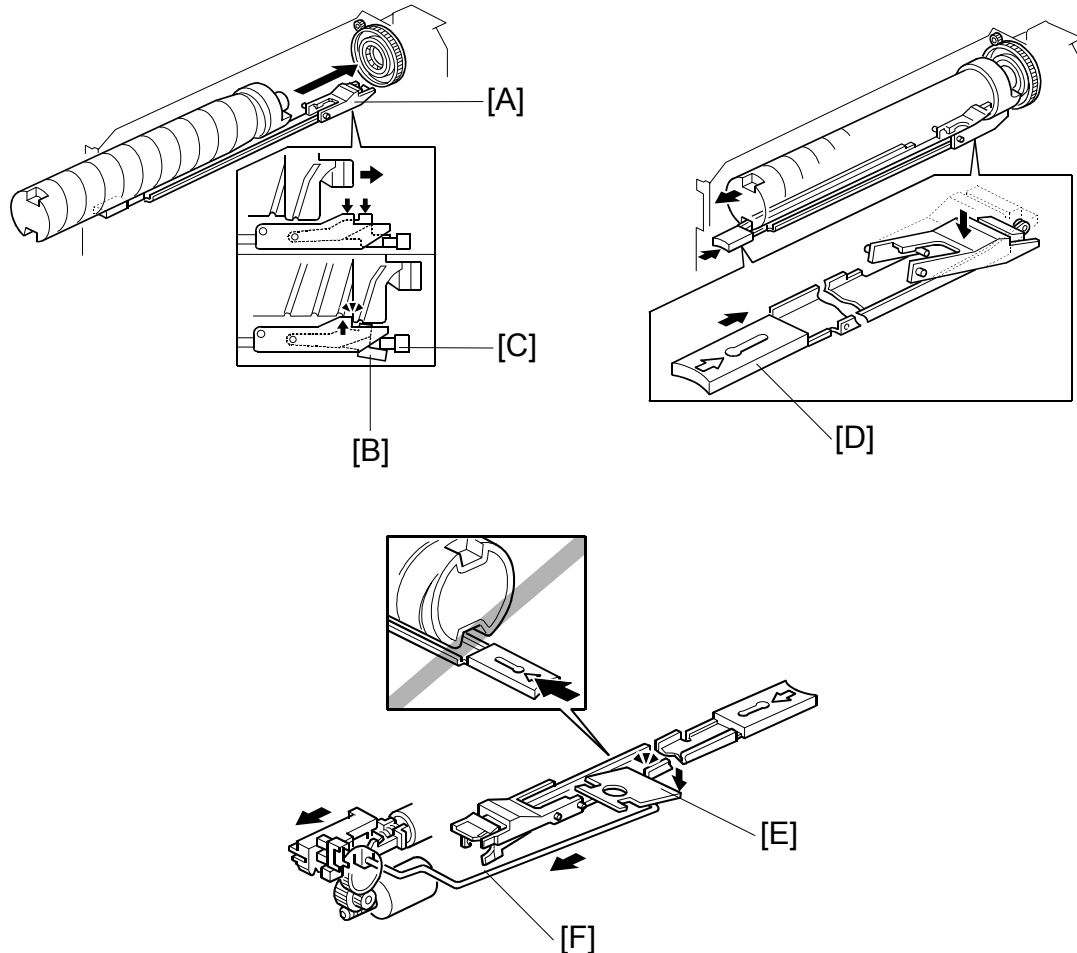

When placing a toner bottle in the toner bank, the toner bottle pushes the lock arm [A] downwards. Then the lock arm catches the toner bottle and also pushes down lever [B]. This causes toner bottle sensor [C] to detect that a bottle has been installed (the actuator leaves the toner bottle sensor while the bottle is being inserted in the holder). When replacing a toner bottle, push the toner bottle release lever [D] to release the lock mechanism. While a toner bottle is supplying toner, the toner bottle opening rod is pulled to the rear and the lock plate [E] is lowered by the link [F] so that the toner bottle release lever cannot be pushed. Therefore, the toner bottle that is supplying toner is always locked in place, and the user cannot pull out the bottle until it is empty.

2.7.3 SUPPLYING TONER TO THE DEVELOPMENT UNIT

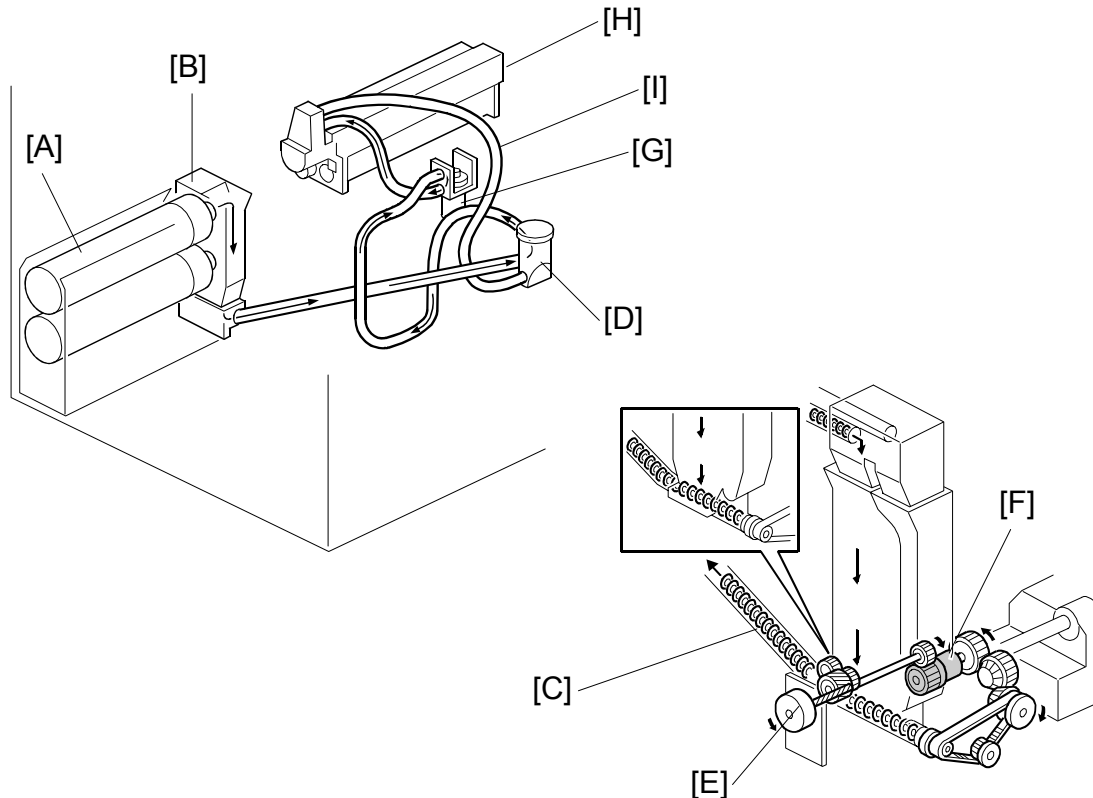

The toner bottle motor turns the toner bottle [A], causing toner to leave the bottle and drop into the toner entrance tank [B].

NOTE: Recycled toner in the tube from the drum cleaning unit also enters the toner entrance tank, and is mixed with fresh toner from the toner bottle.

The toner transport coil [C] in the toner transport tube transports toner to the toner supply cylinder [D]. The toner bank motor [E] drives the toner transport coil via the toner supply coil clutch [F].

The toner supply pump motor [G] creates the suction needed to draw the toner from the toner supply and send it to the toner hopper [H].

The toner hopper has two air pressure release filters and an air return tube [I] connected to the toner supply cylinder. Air returns to the toner supply cylinder from the toner hopper through the air return tube.

If the toner hopper sensor (in the toner hopper -  Toner Hopper) detects an insufficient amount of toner in the hopper, the toner bank mechanism is started up.

If there is sufficient toner in the toner entrance tank (detected by the toner near end sensor in the toner bank), the toner supply coil clutch turns on for 2 seconds. The toner supply pump motor turns on for 7 seconds at the same time as the toner supply coil clutch.

Next, if the toner hopper sensor still does not detect toner, the toner supply coil clutch turns on for 2 seconds again until the toner hopper sensor detects toner (this is done a maximum of 10 times). When the toner hopper sensor detects toner, the toner supply pump motor turns off 1 second after the toner supply coil clutch turns off.

If the toner hopper sensor does not detect toner in the toner hopper after the toner supply coil clutch has turned on 10 times, the operation panel returns SC495 (Toner Bank Error).

The toner supply pump motor sensor (mounted on the toner supply pump motor) monitors the operation of the pump motor. If the sensor detects that the motor does not rotate during the toner supply process, the operation panel returns SC591 (Toner Supply Motor Lock) and the job halts.

2.7.4 TONER HOPPER

Toner Supply

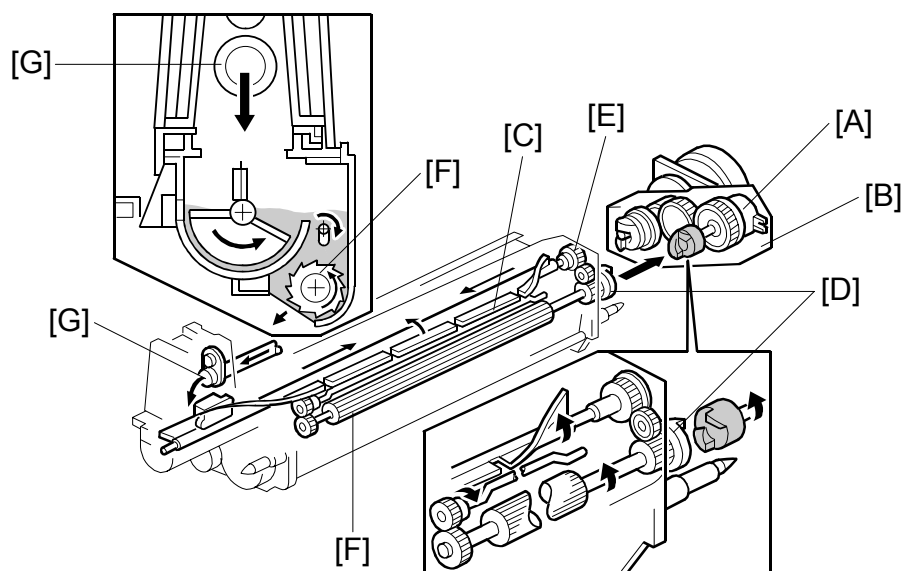

When the toner supply roller clutch [A] (inside the development motor unit [B]) turns on, the agitator [C] mixes the toner transported by the air tube [G] from the toner bank (the toner from the toner bank is new toner mixed with recycled toner). Then it moves the toner from front to rear and sends it to the toner supply roller. Toner is caught in the grooves in the toner supply roller [F]. Then, as the grooves turn past the opening, the toner falls into the development unit.

The toner supply roller clutch [A] transfers drive from the development motor to the toner supply roller gear [D], which drives the agitator gear [E].

For details about Toner Supply Control, see Drum Unit – Toner Supply Control.

Toner Hopper Empty Detection

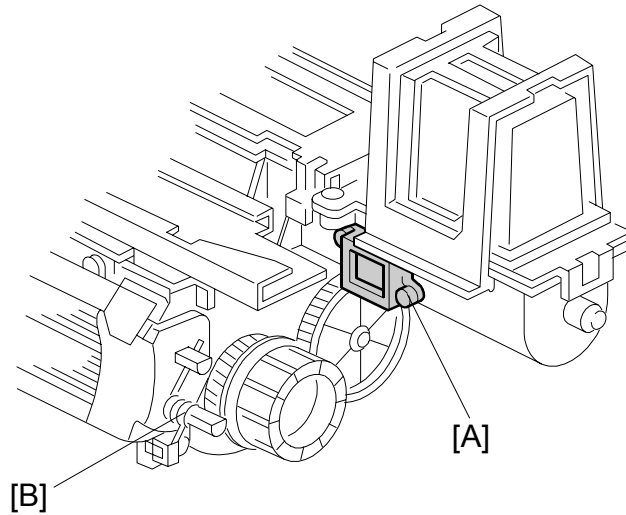

The toner hopper sensor [A] detects whether there is enough toner in the toner hopper. The toner hopper sensor checks for toner once when the toner supply roller clutch turns on. When there is only a small amount of toner inside the toner hopper and pressure on the toner hopper sensor becomes low, the toner hopper sensor outputs a pulse signal (once per copy). Then the toner bank mechanism supplies more toner to the toner hopper, as explained in previous sections.

Spring [B] applies development bias from the developer rollers to the lower case of the developer unit, to prevent toner from being re-attracted back to the drum.

2.7.5 TONER RECYCLING AND WASTE TONER COLLECTION

Overview

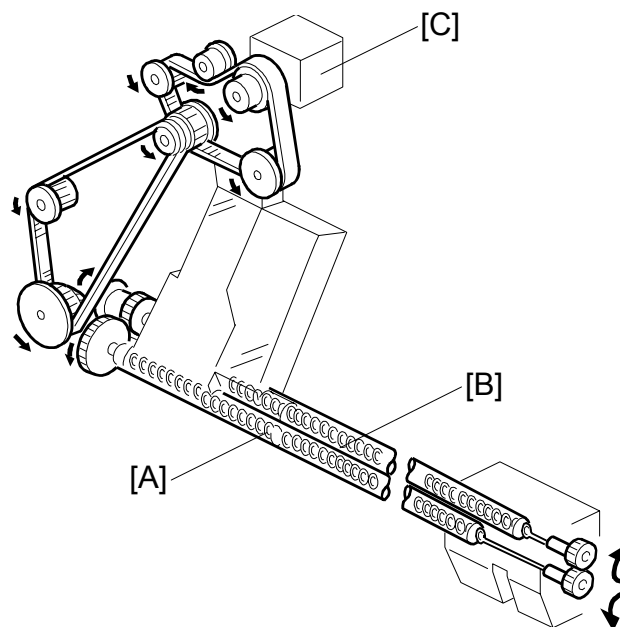

To recycle used toner for re-use, the toner recycling coil in the tube [A] transports the toner collected by the drum cleaning to the toner entrance tank for recycling.

To collect waste toner that will no longer be used, the toner collection coil in the tube [B] transports the toner collected by the transfer belt unit to the waste toner collection bottle.

The drum motor [C] drives the toner recycling coil [A] via timing belts and gears, whose rotation in return drives the toner collection coil [B] via gears.

Toner Recycling

The toner recycling coil in the tube [A] transports the toner collected by the drum

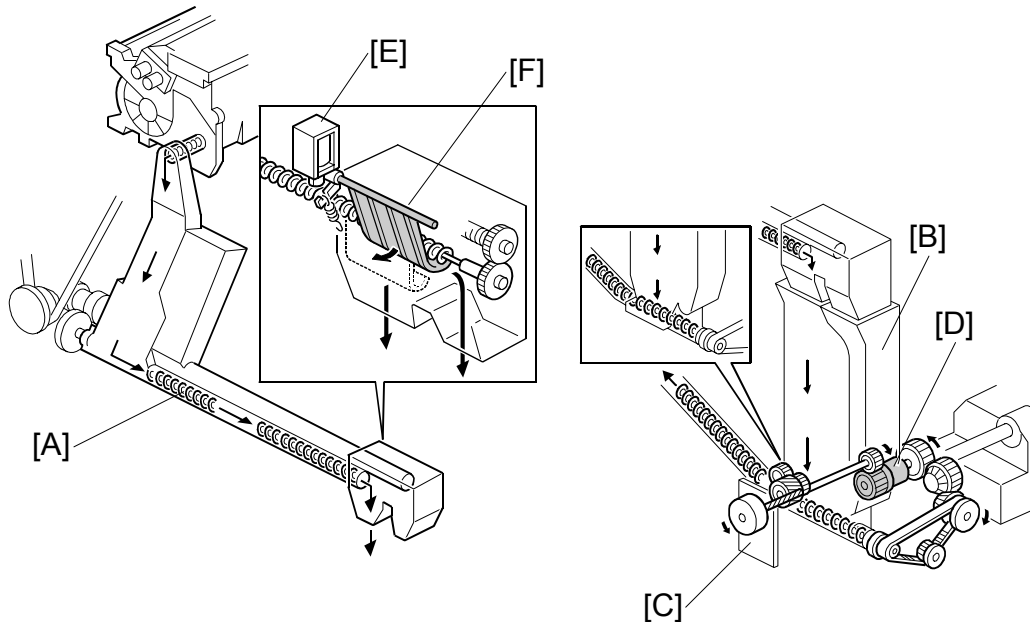

cleaning unit to the toner entrance tank [B] for recycling. This toner is dropped into the toner entrance tank and mixed with fresh toner from the toner bottle. The toner bank motor [C] drives the toner transport coil via the toner supply coil clutch [D].

The new toner separation shutter mechanism (toner recycling shutter solenoid [E] and shutter [F]) reduces the amount of paper dust in the toner. During recycling, paper dust gradually collects in the toner, which can cause black dots to appear on copies. At the prescribed interval, the toner separation mechanism purges all toner from the toner supply system and replaces it with new toner, as described below.

Normally during toner recycling, the toner recycling shutter solenoid remains on and the shutter remains open, but when the number of copies exceeds 200K, the toner recycling shutter solenoid switches off and the shutter closes.

After the solenoid switches off, no toner recycling is done for the next 25K copies, and all used toner is sent to the waste toner collection bottle without recycling. Toner from the toner hopper takes about 20K copies to pass through the recycling path cleaning and collection tubes, so during the 25K copies after the solenoid switches off, all the toner in the toner supply path is purged from the system and replaced with fresh toner.

NOTE: The timing of this operation can be adjusted with SP2975 001, 002 (Toner Recycle Cut Counter – ON Counter/OFF Counter). SP2975 001 determines how often the toner is purged (default: 200k), and SP2975 002 determines how long the purge is done for (default: 25k copies)

2.8 PAPER FEED

2.8.1 OVERVIEW

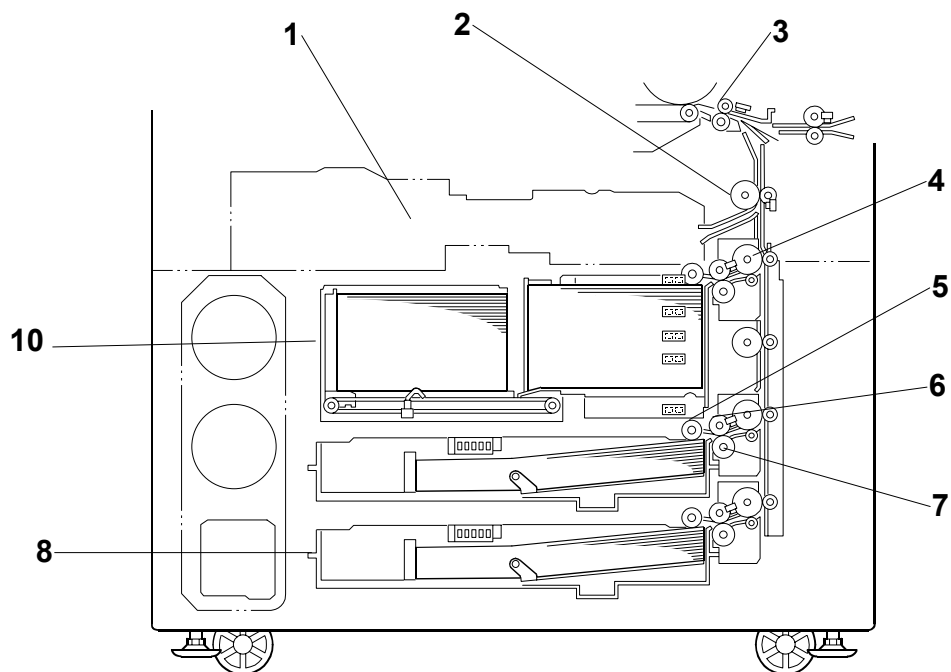

- | | |
|------------------------------|-------------------------|
| 1. Duplex Tray | 6. Feed Roller |
| 2. Relay Roller | 7. Separation Roller |
| 3. Upper Registration Roller | 8. 3rd Tray (Universal) |
| 4. Grip Roller | 9. 2nd Tray (Universal) |
| 5. Pick-up Roller | 10. 1st Tray (Tandem) |

This model has three paper tray feed stations. The 1st tray (10), the tandem feed tray, holds 2,000 sheets of paper (1,000 sheets x 2 stacks). The tandem tray also can be converted to a 1,000-sheet tray for larger paper sizes with the optional A3/DLT Feed Kit B331.

The 2nd tray (9) and 3rd trays (8) are universal trays and each can hold 500 sheets of paper. To allow easy removal, the paper cassettes are not fastened to the trays with screws.

All feed stations use an FRR feed system. Rotation of the pick-up roller (5) drives the top sheet of paper to the feed (6) and separation (7) rollers. These rollers then take over the paper drive. If the pick-up roller feeds more than one sheet, the separation rollers rotate in the opposite direction and prevent all but the top sheet from passing through to the registration rollers. The large grip rollers (4) feed paper from the trays in the vertical paper path.

2.8.2 DRIVE

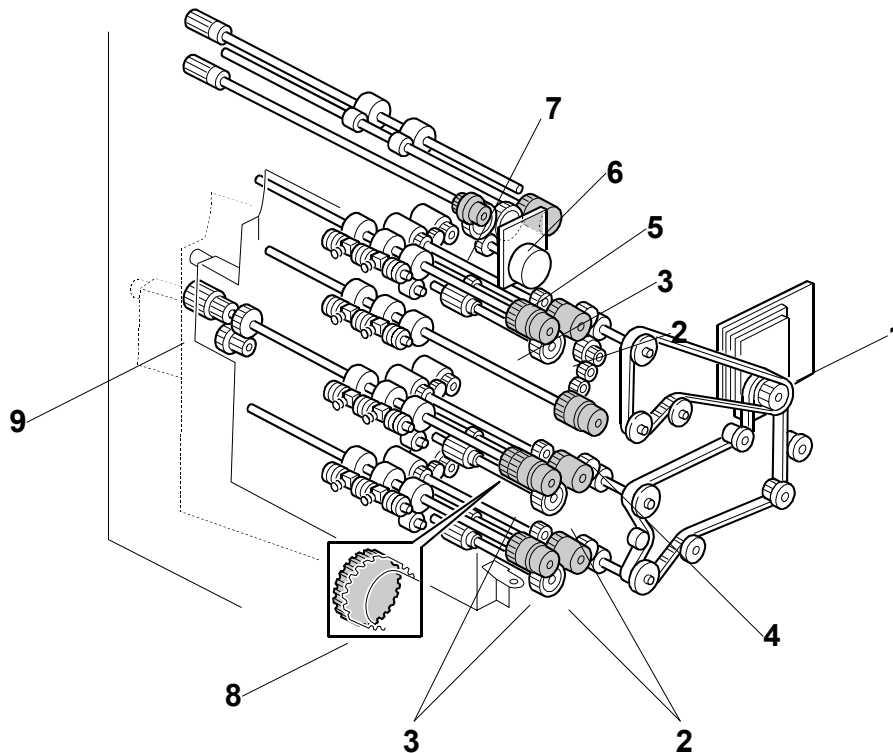

- | | |
|---------------------------------------|-----------------------|
| 1. Paper Feed Motor | 6. Upper Relay Clutch |
| 2. Paper Feed Clutches 1 to 3 | 7. LCT Relay Clutch |
| 3. Vertical Transport Clutches 1 to 3 | 8. One-way Gear |
| 4. Lower Relay Clutch | 9. Knob |
| 5. Relay Motor | |

The paper feed motor (1) drives feed, pick-up, and separation rollers in trays 1, 2, and 3 via timing belts, clutches (2), and gears. The paper feed motor also drives the vertical transport rollers and the lower relay roller. Drive is transferred to each of the three vertical transport rollers by a vertical transport clutch (3), and to the lower relay roller by the lower relay clutch (4).

The relay motor (5) drives the upper relay roller and LCT relay roller via gears and clutches (6) and (7).

The 2nd vertical transport clutch has a one-way-gear (8). This prevents the clutch from slipping when the knob (9) is turned to remove jammed paper in the paper feed tray and vertical transport area.

2.8.3 VERTICAL TRANSPORT

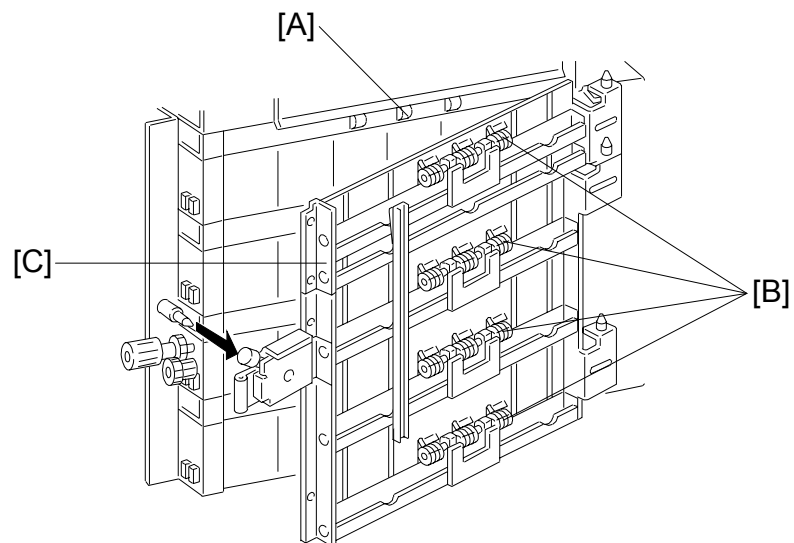

The vertical transport rollers [A] in each feed unit are all driven by the paper feed motor. The vertical transport rollers and the vertical transport idle rollers [B], on the inner and outer vertical guide plates, transport the paper up from each feed unit towards the relay and registration rollers.

The vertical transport guides [C] can be opened to remove jammed paper in the vertical transport area.

2.8.4 PAPER REGISTRATION

Overview

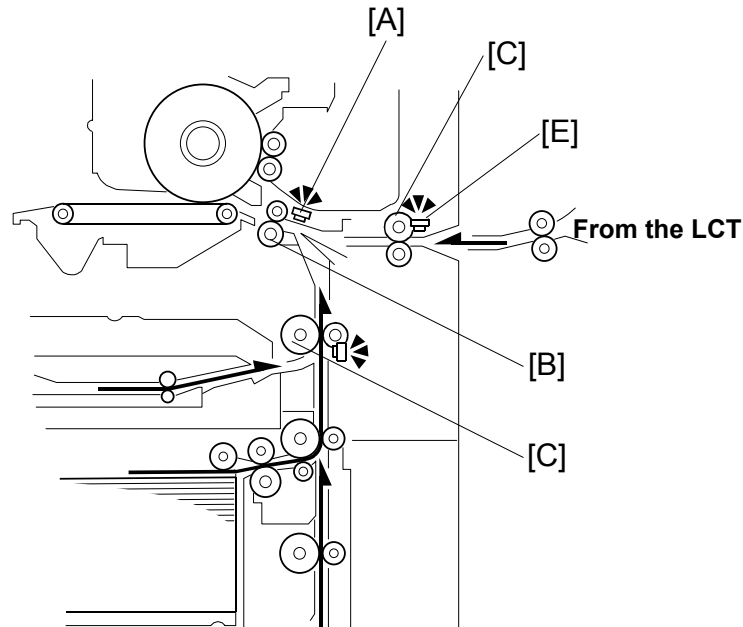

The registration sensor [A] is positioned just before the registration rollers [B]. When the paper leading edge activates the registration sensor, the registration motor is off and the registration rollers are not turning. However, the upper relay roller (or LCT relay roller for feed from the LCT) [C] stays on for a bit longer. This delay allows time for the paper to press against the registration rollers and buckle slightly to correct skew. Next, the registration motor energizes and the upper relay clutch re-energizes at the proper time to align the paper with the image on the drum. The registration and relay rollers feed the paper to the image transfer section. The registration sensor is also used for paper misfeed detection, and the LCT relay sensor [E] detects jams at the LCT roller.

2.9 IMAGE TRANSFER AND PAPER SEPARATION

2.9.1 OVERVIEW

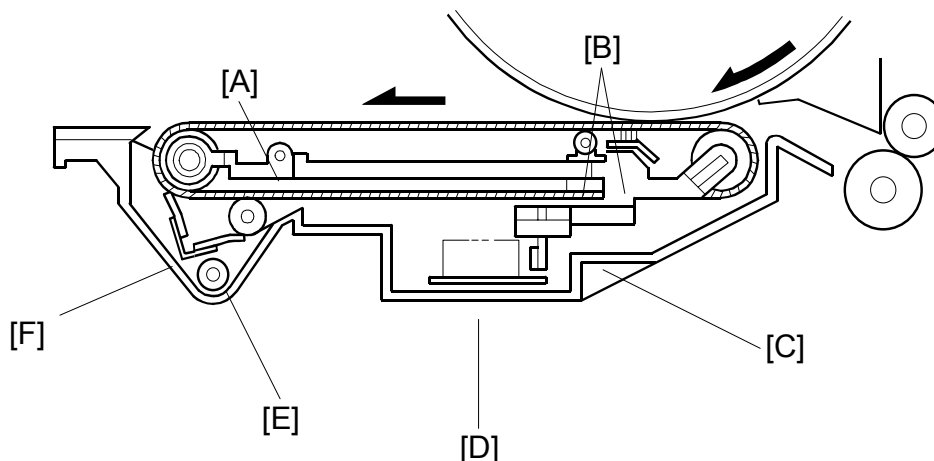

The transfer belt unit consists of the following parts:

- [A]: Transfer belt
A belt (length: 321 mm) with high electrical resistance which holds a high positive electrical potential to attract toner from the drum to the paper. Also, the electrical potential attracts the paper itself and helps the paper to separate from the drum.
- [B]: Transfer bias roller and transfer belt bias brush
Applies transfer voltage to the transfer belt.
- [C]: Transfer belt lift lever (driven by a solenoid)
Lifts the transfer belt into contact with the drum.
- [D]: Transfer power pack
Generates a constant transfer current.
- [E]: Cleaning roller and cleaning roller cleaning blade
Removes toner remaining on the transfer belt to prevent the rear side of the paper from getting dirty.
- [F]: Transfer belt cleaning blade
Removes toner from the transfer belt. Any toner that is not removed by this blade is removed by the cleaning roller [E].

2.9.2 TRANSFER BELT UNIT LIFT

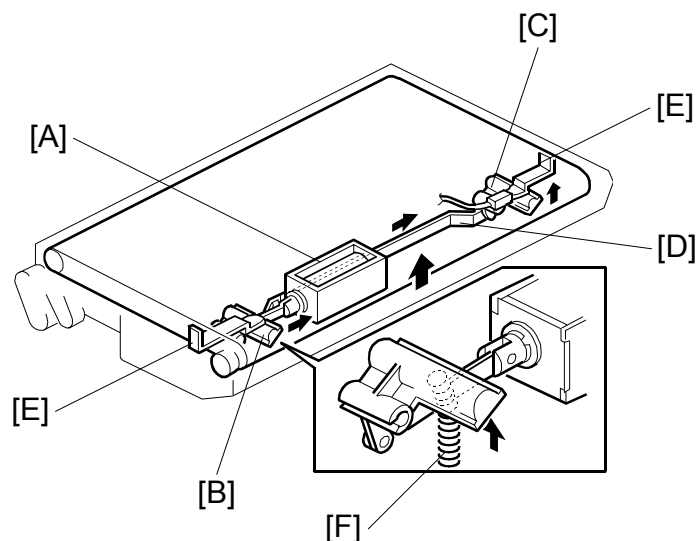

The transfer belt lift solenoid [A] inside the transfer belt unit turns on to raise the transfer belt into contact with the drum. The front lever [B] and the rear lever [C] are connected to the solenoid by links [D], and they push up the stays [E] when the solenoid turns on.

The support spring [F] helps the solenoid to raise the transfer belt.

The solenoid turns off after the copy job is finished.

The transfer belt must be released from the drum for the following reasons:

1. To prevent the ID sensor pattern on the drum from being rubbed off by the transfer belt, because the transfer belt is located between the development unit and the ID sensor.
2. To decrease the load on the bias roller cleaning blade, it is better to prevent toner on non-image areas (for example VD, VH, ID sensor patterns developed during process control data initial setting) from being transferred onto the transfer belt.
3. To prevent drum characteristics from being changed by remaining in contact with the rubber belt.

2.9.3 TRANSFER BELT CLEANING

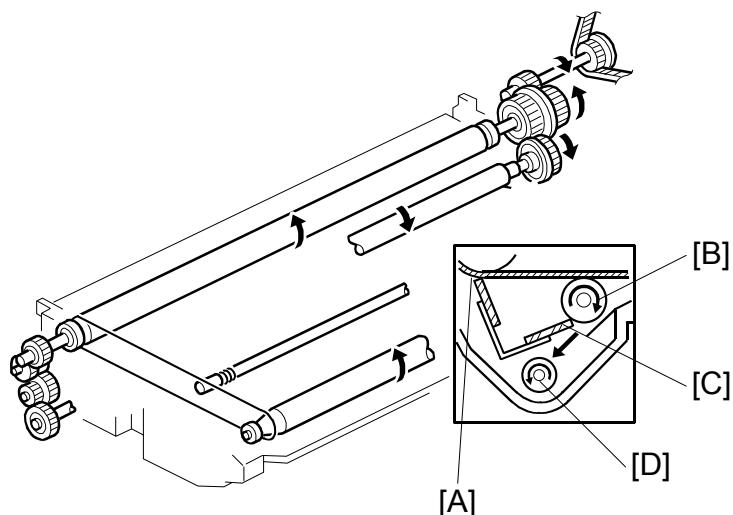

Some toner may adhere to the transfer belt when paper jams occur. The adhered toner must be removed to prevent the rear side of the copy paper from getting dirty. The cleaning blade [A] scrapes off any toner remaining on the transfer belt. This is a counter blade system.

Even if the toner is not completely removed due to paper dust stuck on the transfer belt cleaning blade [A], the positively charged cleaning bias roller [B] attracts the remaining toner. The bias roller cleaning blade [C] scrapes toner off the cleaning bias roller.

The surface of the transfer belt is coated to make it smooth and prevent the transfer belt from flipping the cleaning blade.

The toner collection coil [D] transports toner cleaned off the transfer belt to the waste toner collection bottle (see Toner Supply and Recycling for more on this).

2.9.4 TONER COLLECTION

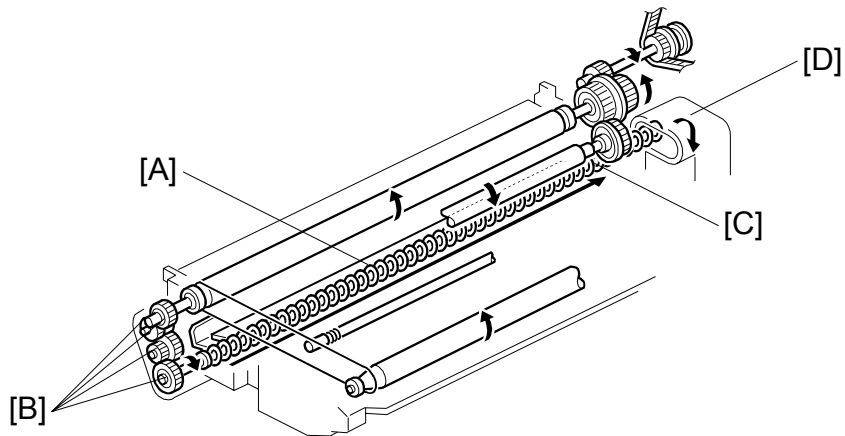

Transfer belt drive is transmitted to the toner collection coil [A] through idle gears [B]. The toner collection coil [C] transports the collected toner to the toner recycling unit [D] and from there it goes to the waste toner collection bottle. See Toner Supply and Recycling for details.

2.9.5 DRUM ANTI-CONDENSATION HEATER

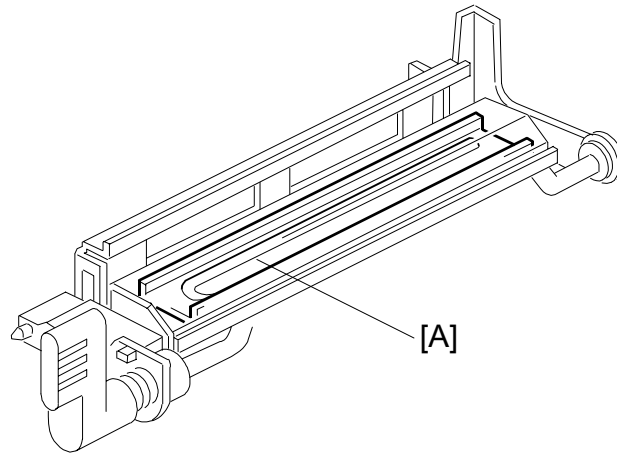

The drum anti-condensation heater [A] is located under the transfer belt unit. It turns on when the main switch is off to prevent moisture from forming on the transfer belt. The heater is included in the machine at the factory, but the connector is not connected.

2.10 FUSING

2.10.1 OVERVIEW

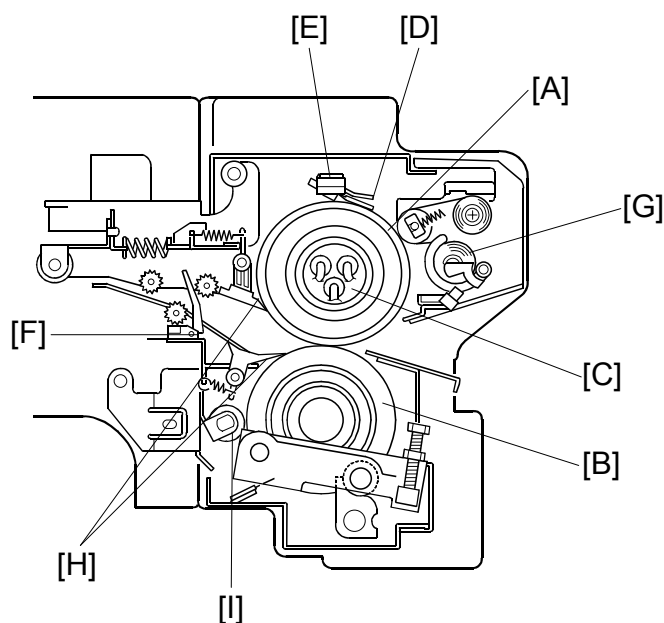

After transferring the image, the copy paper enters the fusing unit. A heat and pressure process using a hot roller [A] and a pressure roller [B] fuses the image to the copy paper. There are three fusing lamps of different wattage [C] inside the hot roller. They are turned on and off to maintain the target fusing temperature.

The CPU monitors the hot roller surface temperature through a thermistor [D], which is in contact with the hot roller's surface. A thermostat [E] protects the fusing unit from overheating.

The fusing exit sensor [F] monitors the progress of the copy paper through the fusing unit and acts as a mis-feed detector while the exit rollers drive the copy paper to the inverter section.

The oil supply roller and cleaning web [G] applies a light coat of silicone oil to the hot roller. It also removes the paper dust on the hot roller.

The hot roller and pressure roller have stripper pawls [H] to prevent wrap-around jams.

The pressure roller is cleaned by a steel cleaning roller [I]. Toner adheres to steel more readily than to silicone rubber.

2.10.2 OIL SUPPLY AND CLEANING

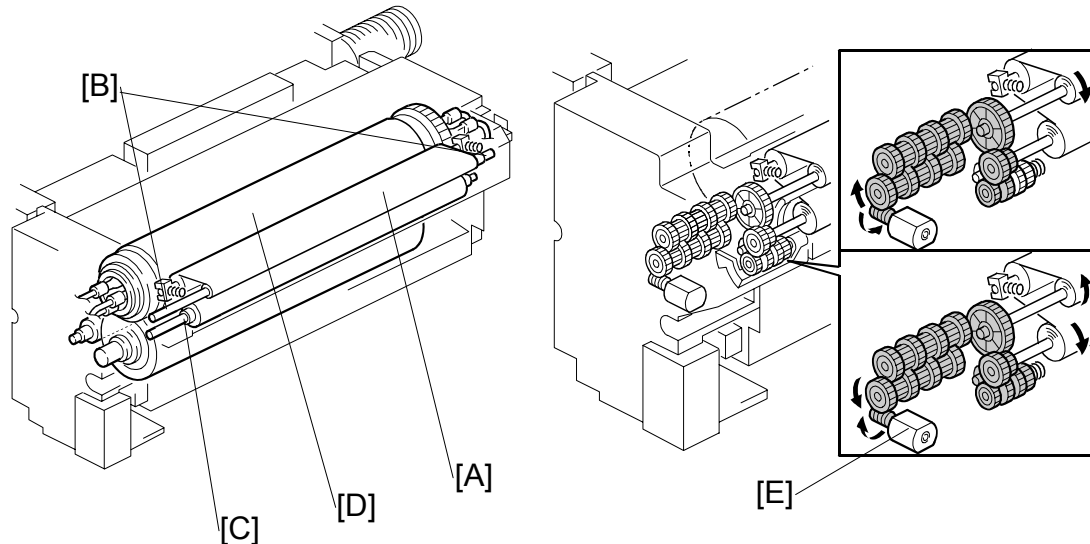

The oil supply and cleaning web [A] feeds the web felt soaked with silicone oil. Springs [B] hold a roller under the web [C] against the hot roller [D].

This intermediate roller applies a light coat of silicone oil to the hot roller and removes paper dust and toner from the hot roller.

A spring clutch inside the mechanism pulls the web to take up the slack, to prevent it getting pulled in between the fusing rollers.

At prescribed intervals (see below), the web motor [E] switches on for 2.8 sec. to move the oil supply and cleaning web felt.

Web Motor Run Time Intervals

	B070 (90 cpm)	B071 (105 cpm)
NA	20.7 s	17.0 s
EUR/A	12.6 s	10.4 s

The interval starts when the first copy reaches the fusing exit sensor, and ends 2 sec. after the last copy has passed this sensor. SP1902 002, 003 (Web Motor Control – Web Motor Drive Interval, Web Motor Drive Time) can be used to adjust the motor rotation time and rotation interval. SP1902 004 (Web Motor Control - Web Near End Setting) is used to adjust the near end timing for the web (Default: 90% for NA, 86% for EUR/A).

The web is 20 m long and lasts for about 600K copies for NA, or 350K copies for EUR/A.

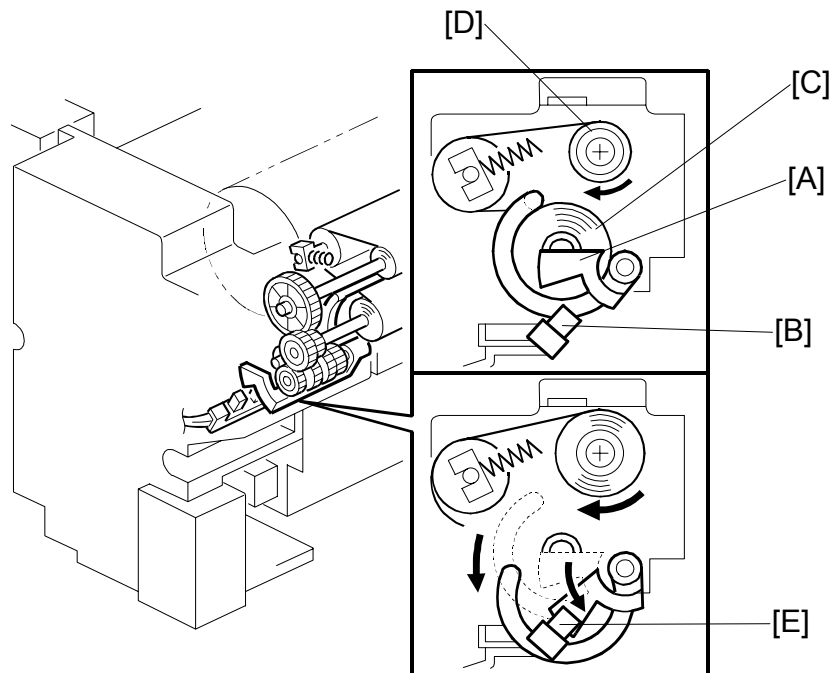

SP1902 001 displays the web consumption. When the web consumption exceeds the value set with SP1-902-4 (Web Near End), the machine indicates web near-end on the operation display.

The machine still operates while the actuator [A] remains above the web end sensor [B] undetected. The actuator arm of the actuator remains in contact with the supply roller [C] and gradually lowers as the amount of web on the supply roller grows smaller as it is fed to the take-up roller [D] above.

When the web runs out, the actuator drops into the web end sensor at [E] and the sensor signal to the CPU displays SC550 on the operation panel display. In this condition, a technician must install a new oil supply and cleaning web, and then reset SP1902 001 to 0 to clear SC550.

SP1902 004 (Web Near End) can be adjusted to change the near-end period. The defaults for and amount of web that remains for copying are different for NA and EUR/A.

Near-End

Area	Near-End	Web Remaining
NA	90%	600K
EUR/A	86%	350K

The table below, provided for your reference, shows approximately how adjustment of SP1902 002 affects the near-end and end displays on the B070 (90 cpm) or B071 (105 cpm).

Note that adjustment of SP1902 002 also affects SP1902 005 (Web Motor Control – Web Motor Drive Interval (Low Speed)).

SP1902 002 ^{*1}			SP1902 004 ^{*3}	Near-End Display (Sheets) ^{*4}	End Display (Sheets)	Comments
B070	B071	Low Speed Mode ^{*2}				
20.7 s	17.0 s	25.3 s	90%	600K	670K	NA Default
15.6 s	12.8 s	19.0 s	90%	450K	500K	
12.1 s	10.0 s	14.8 s	90%	350K	385K	
10.4 s	8.5 s	12.7 s	90%	300K	330K	
6.9 s	5.7 s	8.5 s	90%	200K	220K	
12.6 s	10.4 s	15.4 s	86%	350K	410K	EUR/A Default
10.8 s	9.0 s	13.2 s	86%	300K	350K	
7.2 s	6.0 s	8.8 s	86%	200K	230K	

*1: SP1902 002 (Web Motor Control – Web Motor Drive Interval)

*2: SP1902 005 (Web Motor Control – Web Motor Drive Interval (Low Speed))

*3: SP1902 004 (Web Motor Control – Web Near End Setting)

*4: Calculated based on A4 LEF at 100% magnification.

NOTE: SP1902 003 (Web Motor Control – Web Near End Setting) not adjusted.

2.11 PAPER EXIT/DUPLEX

2.11.1 OVERVIEW

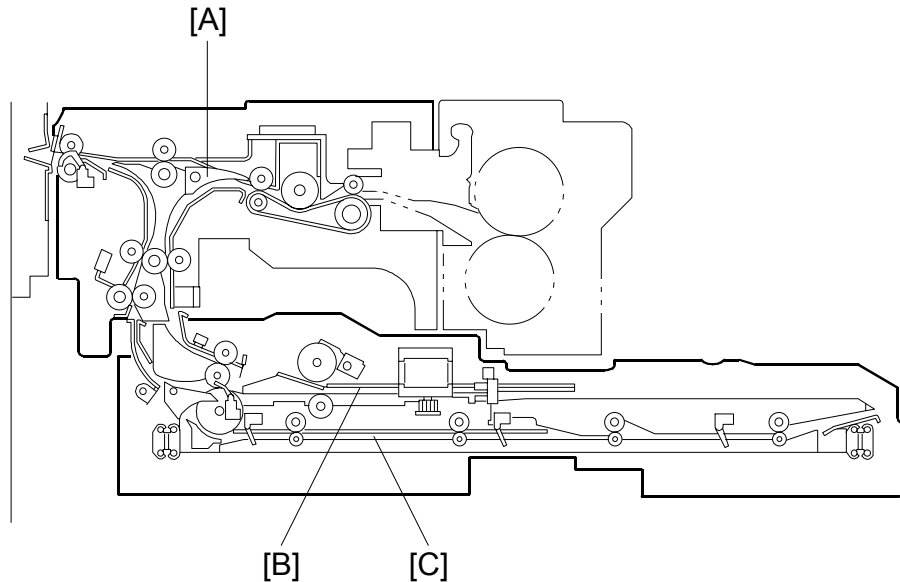

The printed page from the fusing unit goes either straight through to the output tray or finisher, or downward through to the inverter or duplex unit, depending on the position of the junction gate [A].

If the page is fed out directly, it arrives on the tray face-up. If the user selected face-down output, the page goes to the inverter [B] before being fed out.

If the user selects duplex mode, the page is directed to the duplex tray [C] after inverting, and back to the machine for printing the second side.

2.11.2 INVERTER

Feed-in and Jogging

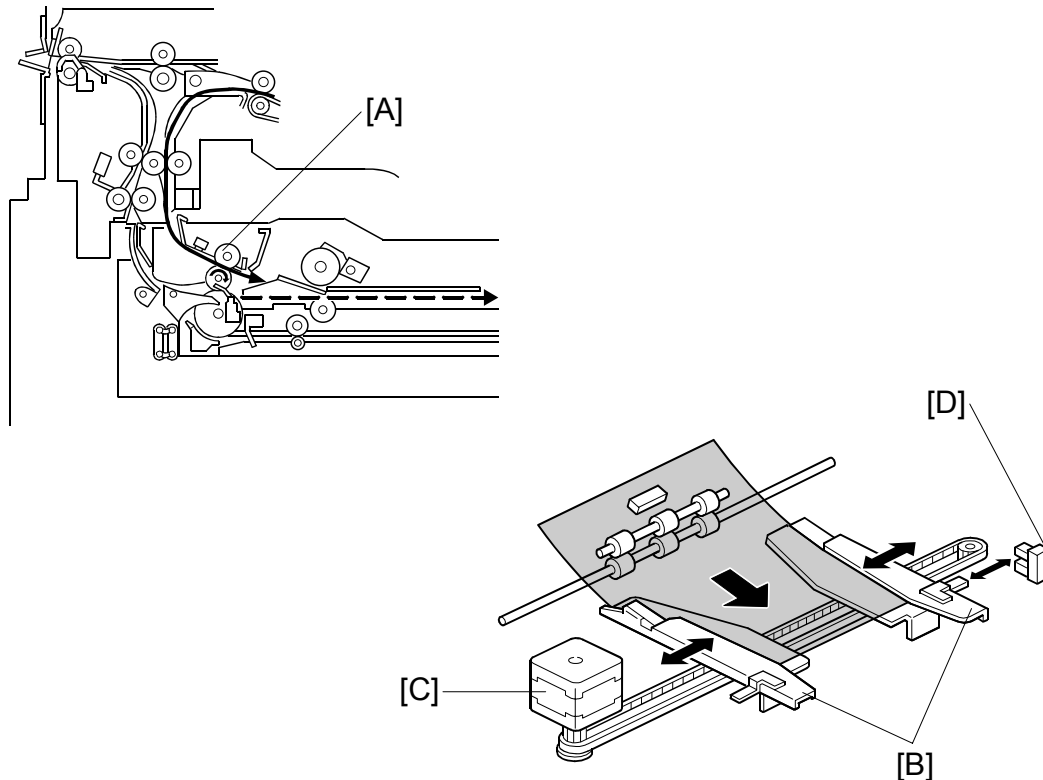

The inverter feed roller [A] feeds paper to the jogger section. After the trailing edge of the paper passes through the inverter feed roller, the jogger fences [B] move to square the paper. This happens every page.

The jogger motor (a stepper motor) [C] moves the jogger fences [B] inward or outward.

When the main switch is turned on, the jogger motor places the jogger fences at the home position, which is determined by monitoring the signal from the jogger home position sensor [D].

When the start key is pressed, the jogger motor positions the jogger fences 15 mm away from the selected paper size to wait for the paper.

When the paper is delivered to the jogger fences, the jogger fences move inward to square the paper. After this, the jogger fences move back to the previous position (15 mm away from the paper).

Feed-out

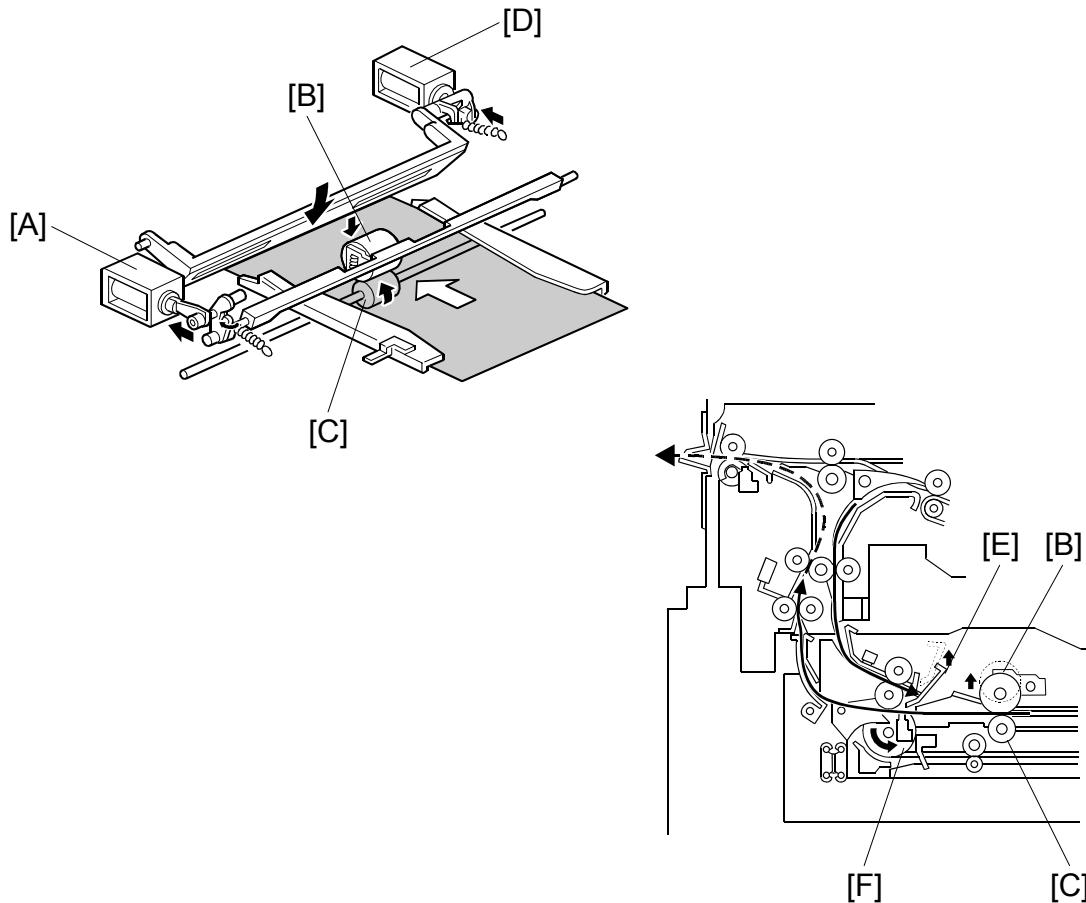

After jogging, the reverse roller solenoid [A] energizes to push down the reverse trigger roller [B]. The reverse roller [C] turns counterclockwise continuously, so the paper starts to reverse when the reverse trigger roller is down and catches the paper between the rollers. The inverter guide plate solenoid [D] energizes to lower the inverter guide plate [E], so that the paper is guided by the inverter guide plate. The next sheet waits at the inverter guide plate.

The paper is fed from the reverse roller to the inverter exit roller [F]. After the paper starts to be fed by the inverter exit roller, the reverse trigger roller and inverter guide plate move back up.

2.11.3 DUPLEX TRAY FEED MECHANISM

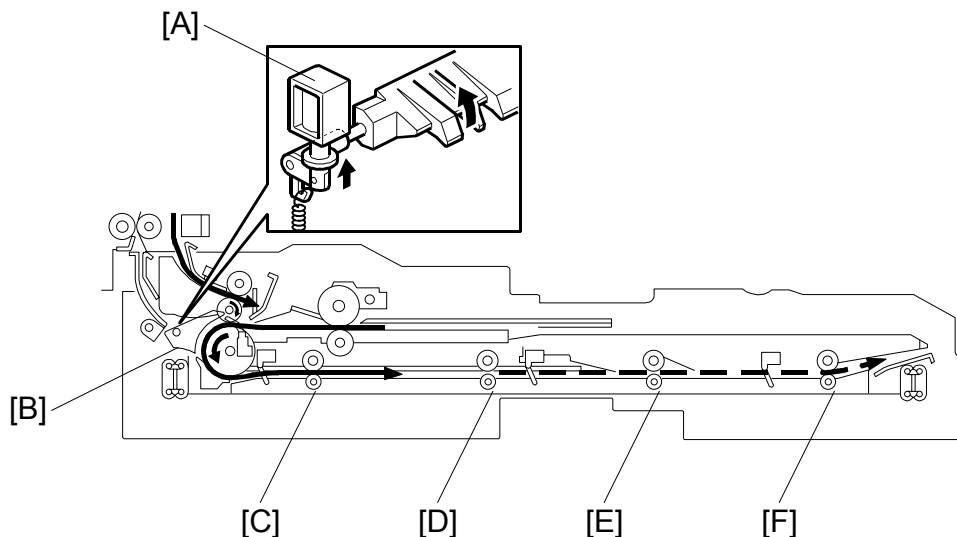

In duplex mode, after the paper leaves the inverter, the duplex inverter gate solenoid [A] switches the junction gate [B] to direct the paper to the duplex tray. The paper is fed through the duplex tray by duplex transport rollers 1 [C], 2 [D], 3 [E], and the duplex feed roller [F].

If duplex mode is not selected, the solenoid does not switch the junction gate, and the paper goes to the output tray or finisher face down.

2.11.4 BASIC DUPLEX FEED OPERATION

To improve the productivity of duplex copying, a non-stacking style duplex mechanism is adopted. This type of mechanism allows more than one page to be processed at once, in a process called 'interleaving'. Examples of this are given below.

For paper lengths up to A4/Letter LEF, the top duplex speed is possible, with the duplex unit processing four sheets of copy paper at the same time.

For paper longer than this, the duplex tray can process two sheets of copy paper at once.

For a single-set duplex copy job, the duplex unit stores only one sheet of copy paper. For a multi-set duplex job, the job is stored first, then the first set is made using interleaving.

Length up to A4/Letter LEF

The duplex unit can process four sheets of copy paper

Example: A 14-page copy. The large numbers in the illustration show the order of pages. The small numbers in circles show the order of sheets of copy paper (if shaded, this indicates the second side).

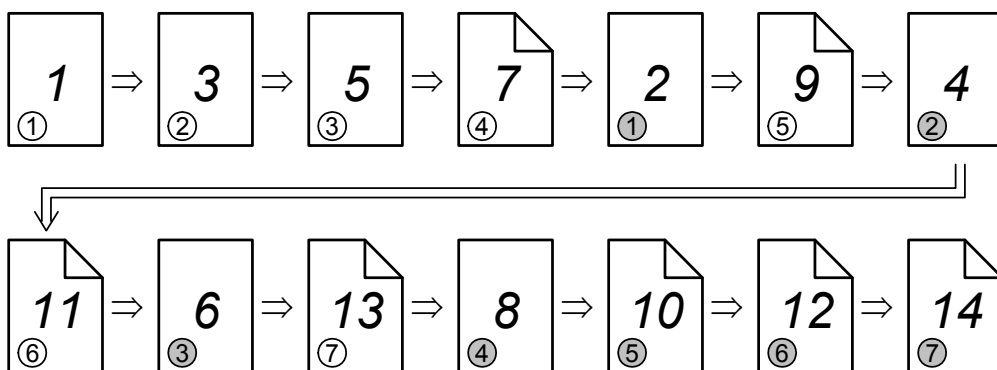

1. The first 4 sheets are fed and printed.

- 1) 1st sheet printed (1st page)
- 2) 2nd sheet printed (3rd page)
- 3) 3rd sheet printed (5th page)
- 4) 4th sheet printed (7th page)

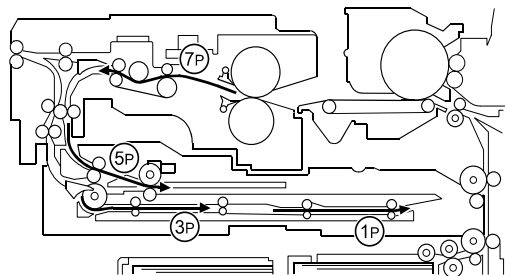

2. The back of the 1st sheet is printed (2nd page).
3. The 2nd, 3rd, 4th sheets (3rd, 5th, and 7th pages) go into the duplex unit.
4. The 5th sheet (9th page) is fed in.

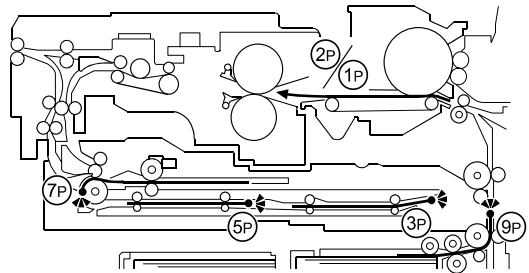

5. The 5th sheet is printed (9th page).
6. The 1st sheet is fed out (1st and 2nd pages printed).

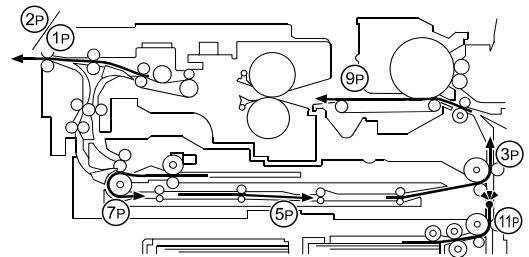

7. The 5th sheet (9th page) is directed to the duplex unit.
8. The 6th sheet (11th page) is fed.
9. The back of the 2nd sheet is printed (4th page).

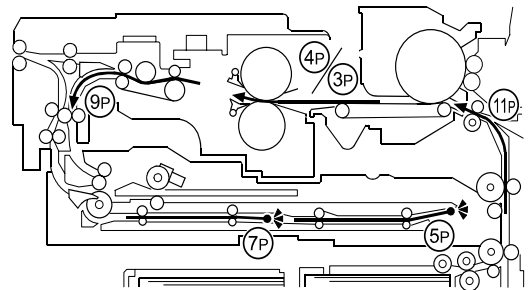

10. The 2nd sheet is fed out (3rd and 4th pages printed).
11. The 6th sheet is printed (11th page) and directed to the duplex unit.
12. The back of the 3rd sheet (6th page) is printed.
13. The 7th sheet is fed and printed (13th page).
14. The back of the 4th sheet is printed (8th page) and fed out (7th and 8th page).
15. The back of the 5th sheet is printed (10th page) and fed out (9th and 10th pages).
16. The back of the 6th sheet is printed (12th page) and fed out (11th and 12th pages).
17. The back of the 7th sheet is printed and fed out (13th and 14th pages).

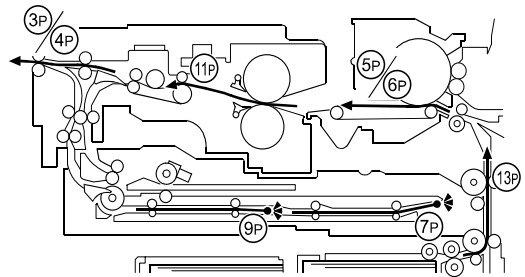

Longer than A4/Letter LEF

The duplex unit can process two sheets of copy paper

Example: 8 pages. The number [A] in the illustration shows the order of pages. The number [B] in the illustration shows the order of sheets of copy paper (if shaded, this indicates the second side).

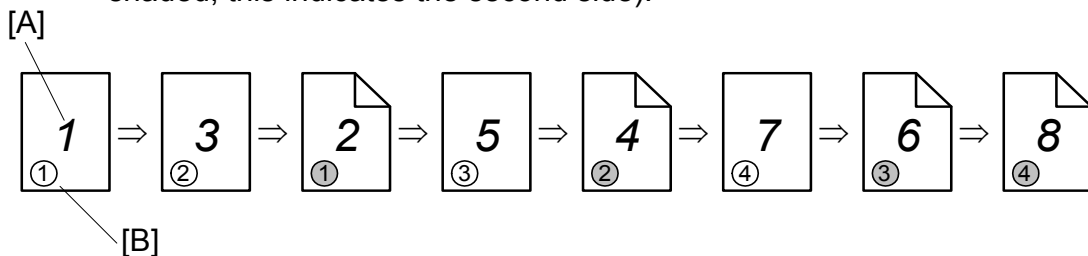

1. The first 2 sheets are fed and printed.
 - 1) 1st sheet printed (1st page)
 - 2) 2nd sheet printed (3rd page)

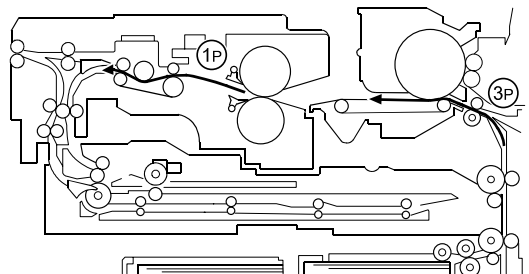

- The first 2 sheets go into the duplex unit.

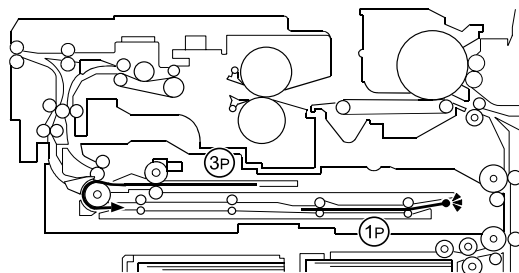

- The back of the 1st sheet (2nd page) is printed.
- The 3rd sheet (5th page) is fed and printed.

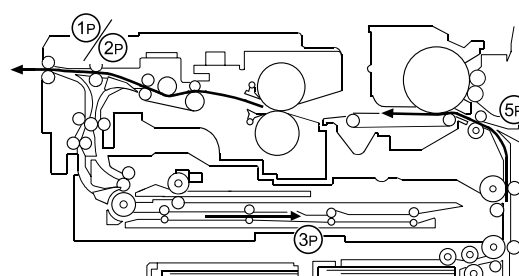

- The 1st sheet (1st and 2nd pages) is fed out.
- The back of the 2nd sheet (4th page) is printed.
- The 4th sheet (7th page) is fed and printed.

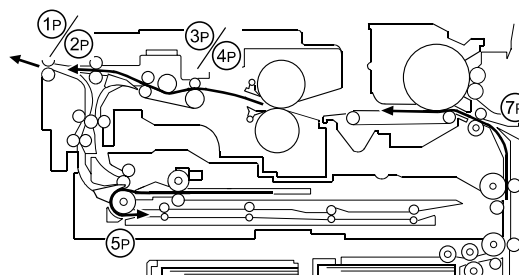

- The 2nd sheet (3rd and 4th pages) is fed out.
- The back of the 3rd sheet (6th page) is printed.
- The 3rd sheet (5th and 6th pages printed) is fed out.
- The back of the 4th sheet (8th page) is printed.
- The 4th sheet (7th and 8th pages) is fed out.

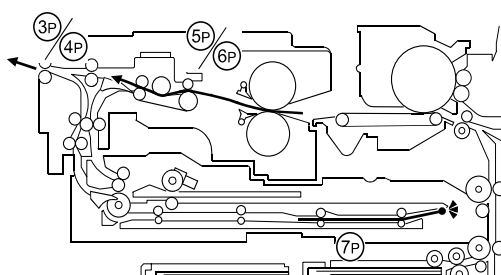

2.12.2 ENERGY SAVER MODE

Entering the energy saver mode

The machine enters energy saver mode when one of the following is done.

- The Energy Saver Key is held down for a second.
- The panel off timer runs out after the last job (User Tools - System Settings - Timer Setting - Panel Off Timer: default setting is 60 s).

What happens in energy saver mode

When the machine enters energy saver mode, the fusing lamp drops to a certain temperature and the operation panel indicators are turned off except for the Energy Saver LED and the Power LED.

If the CPU receives the image print out command from an application (e. g. to print data from a PC), the fusing temperature rises to print the data. However, the operation indicators stay off.

Return to stand-by mode

If one of the following is done, the machine returns to stand-by mode:

- The Energy Saver Mode key is pressed
- An original is placed in the ADF
- The ADF is lifted
- A sheet of paper is placed in the by-pass feed table

Operation Switch	Energy Saver LED	Fusing Temp.	Approx. Recovery Time	System +5V
On	On	168°C (B070/90 cpm) 173°C (B071/105 cpm)	3 s	On

2.12.3 LOW POWER MODE

Entering the low power mode

The machine enters low power mode when:

The energy saver timer runs out after the last job.

(User Tools - System Settings - Timer Setting - Energy Saver Timer: default setting is 15 min)

What happens in low power mode

The fusing lamp drops to the prescribed temperature, as shown in the table below (the temperature drops more than that in energy saver mode). The other conditions are the same as for the energy saver mode.

Return to stand-by mode

The machine returns to standby mode in the same way as from the energy saver mode.

Operation Switch	Energy Saver LED	Fusing Temp.	Approx. Recovery Time	System +5V
On	On	143 °C (B070/90 cpm) 150°C (B071/105 cpm)	40 s	On

2.12.4 AUTO OFF MODE

Auto off mode is used only if no optional printer/scanner unit is installed.

Entering auto off mode

The machine enters auto off mode when one of the following is done.

- The auto off timer runs out after the last job (User Tools – System Settings – Timer Setting – Auto Off Timer: default setting is 90 min)
- The operation switch is pressed to turn the power off

What happens in auto off mode

When the machine enters auto off mode, the fusing lamps and all dc supplies except +5VE/12VE (+5V/12V for energy saver mode) turn off.

Returning to stand-by mode

The machine returns to stand-by mode when the main operation switch is pressed.

Operation Switch	Energy Saver LED	Fusing Temp.	Approx. Recovery Time	System +5V	Note
Off	Off	Room Temp. (Fusing lamp off)	360 s	Off	Only +5VE/+12VE is supplied to the Controller, MB, HDD.

Disabling auto off mode

If the user wishes to disable auto off mode, use the following user tool: User Tools – System Settings – AOF (change the setting to 'OFF').

2.12.5 NIGHT MODE

This is used instead of auto off mode when an optional scanner/printer unit is installed. There are two types of night mode: Night Stand-by Mode and Night Mode. The difference between night stand-by mode and night mode is the machine's condition when the machine enters auto off mode.

Entering night stand-by and night modes

The machine enters the night stand-by mode and night modes when one of the following is done.

- The operation switch is pressed to turn the power off
- The auto off timer runs out (the operation switch is then turned off, but the main power switch stays on)

If the machine is in one or more of the following conditions, the machine enters night stand-by mode. If not, the machine enters night mode.

- Error or SC condition
- Image data is stored in the memory
- An original is in the ADF
- The ADF is open
- Paper is left in the duplex unit or staple tray

What happens in night stand-by and night modes

When the machine enters either of these modes, the fusing lamp and operation switch turn off, and only the main power LED is lit.

Night stand-by mode

The system +5V and +24 V are supplied to all components.

Night mode

The system +5V supply is also turned off. However, +5VE (+5V for energy saver mode) is still activated. When the machine detects a signal from the PC, the machine goes back to night stand-by mode and the system +5V and +24V supplies are activated. Then the machine receives the incoming message and prints it.

Returning to stand-by mode

The machine returns to stand-by mode when the operation switch is pressed.

Mode	Operation Switch	Energy Saver LED	Fusing Temp.	System +5V	Note
Night stand-by mode	Off	Off	Room Temp. (Fusing lamp off)	On	
Night mode	Off	Off	Room Temp. (Fusing lamp off)	Off	Only +5VE/+12VE is supplied to the controller, MB, HDD.

SECTION 3

SERVICE TABLES

3. SERVICE TABLES





3.1 SERVICE PROGRAM MODE OPERATION

The service program (SP) mode is used to check electrical data, change modes, and adjust values.

CAUTION

Never turn off the main power switch when the power LED is lit or flashing. To avoid damaging the hard disk or memory, press the operation power switch to switch the power off, wait for the power LED to go off, and then switch the main power switch off.

To Enter and Exit the SP Mode

1. Press Clear Modes key .
2. On the operation panel keypad, press   .
3. Hold down Clear key  more than 3 seconds.
The Copy SP or PM Counter items are displayed. If the printer or scanner/printer option is installed, the Printer SP and Scanner SP items are also available.
4. Press Copy SP.
5. To exit the SP mode, just press Exit in the upper right corner of the SP mode screen.

To Switch to the Copy Window for Test Printing

1. In the SP mode display, press Copy Window to switch to the copy operation screen when you need to select paper for a test print.
2. Use the copy window (copier mode) to select the appropriate settings (paper size, etc.) for the test print.
3. Press Start key  to execute the test print.
4. Press SP Mode (highlighted) to return to the SP mode screen and repeat from step 1.

Using the SP Mode

SP command numbers can be entered directly (if you know the entire number) or the command can be selected from the menus.

Direct Entry

If you know all seven digits of the SP code, enter the seven numbers and press Enter key (#).

However, if you do not know all the numbers, enter only the first four numbers of the seven-digit SP and press Enter key (#). The display goes immediately to the first SP of that group. Then you can use the buttons to browse to the desired selection.

Button Selection Entry

1. Refer to the SP Mode Tables at the end of this section to find the SP that you want to adjust.
2. Press the Group number on the left side SP Mode window that contains the SP that you want to adjust.
3. Use the scrolling buttons in the center of the SP mode window to display the SP number that you want to open, then, press that number to expand the list.
4. Use the center touch-panel buttons to scroll to the number and title of the item that you want to set, and press Enter key (#). The small entry box on the right is activated and displays the default or the current setting below.
5. To enter a setting
 - Press (*) key to enter a minus sign. Then use the keypad to enter the appropriate number. The number you enter will write over the previous setting.
 - Press (#) to enter the setting. (If you enter a number that is out of range, the key press is ignored.)
 - Press Clear key  to cancel the data.
6. If you need to perform a test print, press Copy Window to open the copy window and select the settings for the test print. Press Start (D) key.
7. Press SP Mode (highlighted) in the copy window to return to the SP mode display.
8. When you are finished, press Exit twice to return to the copy window.

SP Mode Button Summary

Here is a short summary of the touch-panel buttons.

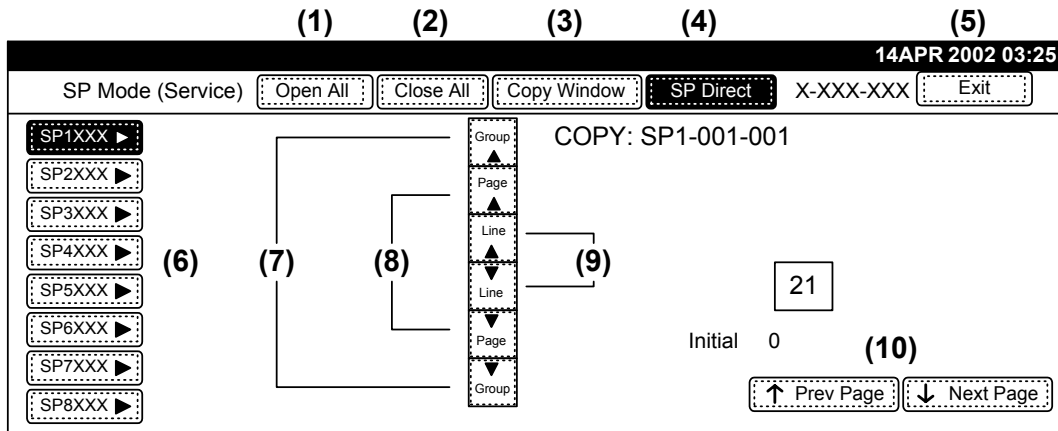

(1)	Open All. Opens all SP groups and sublevels.
(2)	Close All. Closes all open groups and sublevels and restores the initial SP mode display.
(3)	Copy Window. Opens the copy window (copy mode) so you can make test copies. To return to the SP mode screen, press SP Mode (highlighted) in the copy window.
(4)	SP Direct. Enter the SP code directly with the number keys if you know the SP number, then press Enter key (#). (SP Direct must be highlighted before you can enter the number. Just press SP Direct if it is not highlighted.)
(5)	Exit. Press twice to leave the SP mode and return to the copy window to resume normal operation.
(6)	SPnxxx. Press any group number to open a list of SP codes and titles for that group. For example, to open the SP code list for SP1-nnn, press SP1XXX. If an SP has sublevels, it is marked with a right pointing triangle.
(7)	Group. Press to scroll the display to the previous or next group.
(8)	Page. Press to scroll to the previous or next display in segments the size of the screen display (page).
(9)	Line. Press to scroll the display to the previous or next line, line by line.
(10)	Prev Page or Next Page. Press to move the highlight on the left to the previous or next selection in the list.

3.2 SERVICE PROGRAM MODE TABLES

NOTE: The Service Program Mode is for use only by customer engineers so that they can properly maintain product quality. If this mode is used by anyone other than a customer engineer for any reason, data might be deleted or settings might be changed. In such a case image quality can no longer be guaranteed.

Service Table Key

Notation	What it means
[range / default / step]	[-9~+9 / +3.0 / 0.1 mm] The default setting +3.0 can be adjusted in 0.1mm steps in the range ± 9 .
Italics	Comments added for reference.
*	An asterisk marks the SP's that are reset to their factory default settings after an NVRAM reset.
DFU	Denotes "Design or Factory Use". Do not change this value.
Japan only	The feature or item is for Japan only. Do not change this value.
SEF	Short Edge Feed
LEF	Long Edge Feed

NOTE: The intent of this document is to not detail the Service Programs, please use the SM for that purpose.

3.2.1 COPIER SERVICE PROGRAM MODE TABLES

SP1-*nnn* Feed

SP	Number/Name	Function/[Setting]
1001	Leading Edge Registration	Adjusts the printing leading edge registration for feeding from the trays and duplex tray using the trimming area pattern (SP2-902-3, No.15). <i>Use the "•/*key to enter the minus (-) before entering the value. The specification is 4 ± 2 mm. (3-17)</i>
	001 Copier/LCT Paper Tray	B070: [-9.0~+9.0 / -2.6 / 0.1 mm] B071: [-9.0~+9.0 / -4.0 / 0.1 mm]
	002 Duplex Tray	B070: [-9.0~+9.0 / -0.3 / 0.1 mm] B071: [-9.0~+9.0 / -0.4 / 0.1 mm]
	003 Copier//LCT Paper Tray (Low Speed)	B070: [-9.0~+9.0 / -3.0 / 0.1 mm] B071: [-9.0~+9.0 / -2.0 / 0.1 mm]
	004 Duplex Tray (Low Speed)	[-9.0~+9.0 / 0 / 0.1 mm]
1002	Side-to-side Registration	Adjusts the printing side-to-side registration from the 1st paper feed station using the trimming area pattern (SP2-902-3, No.15). <i>Use the "•/*key to enter the minus (-) before entering the value. Specification: 0 ± 2.0 mm. (3-17)</i>
	001 1st Tray (Copier Tandem Tray)	[-9.0~+9.0 / -0.1 / 0.1 mm]
	002 2nd Tray (Copier)	[-9.0~+9.0 / -0.6 / 0.1 mm]
	003 3rd Tray (Copier)	[-9.0~+9.0 / -0.3 / 0.1 mm]
	004 4th Tray (LCT Tray 1)	[-9.0~+9.0 / -0.8 / 0.1 mm]

3.3 USER PROGRAM MODE

3.3.1 ENTERING AND EXITING USER PROGRAM MODE

The user program (UP) mode is accessed by users, and by sales and service staff. UP mode is used to input the copier's default settings.

Press the User Tools/Counter button (Item20), then select the UP mode program. After finishing the UP mode program, touch "Exit" key to exit UP mode.

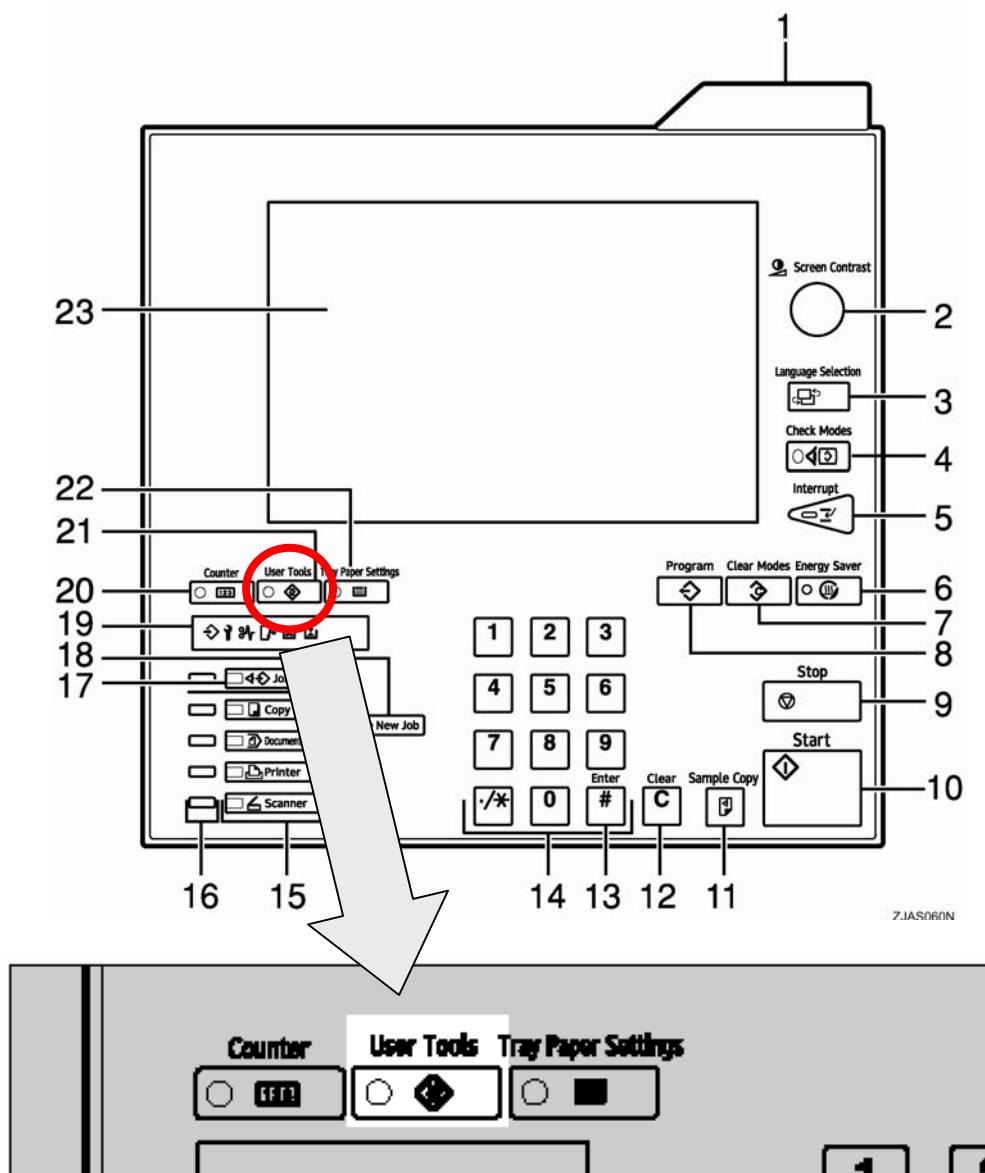

1. Press the user tools key, then press the key corresponding to the set of user tools you wish to use.
2. System Settings:
 - a) Print Priority: If set to Interleave, the machine may start printing pages from another job after the number of pages selected with 'Interleave Print'.
 - b) Interleave Print: See above
 - c) Function Reset Timer: Also controlled by SP 5913. This is the length of time the machine waits before changing modes when using the multi-access function. The default is 3 seconds.
 - d) Output Tray - Printer: The driver settings will take priority if different from the user tool setting.
 - e) System Settings - Key Operator Functions
 - f) User Code Management: Determines which modes user codes are necessary for (copier, document server, scanner, printer)
 - g) External Change Unit Management: Determines which modes key operator code is necessary for (copier, document server, scanner, printer)
 - h) Address Book Management: This allows you to administer the user codes. These user codes are also used for Document Solutions software. E-mail addresses can also be programmed with the user codes, and scanned documents can be sent by e-mail. E-mail addresses can also be registered in groups so that a document can be sent to more than one person at the same time easily.
 - i) For printer mode, user codes sent from the printer driver can be automatically registered in the machine as user codes if you set User Code Management (above) for printer mode to Auto Program.
 - j) Key Operator's e-mail Address: This can be stored for reference in times of confusion, tumult, and chaos.
 - k) AOF: This enables and disables auto off mode. It is not explained in the operation manual. This is because, to comply with Energy Star, it should not be easy to disable this feature.
3. Printer Features, Scanner Features: The printer and scanner options must be installed.

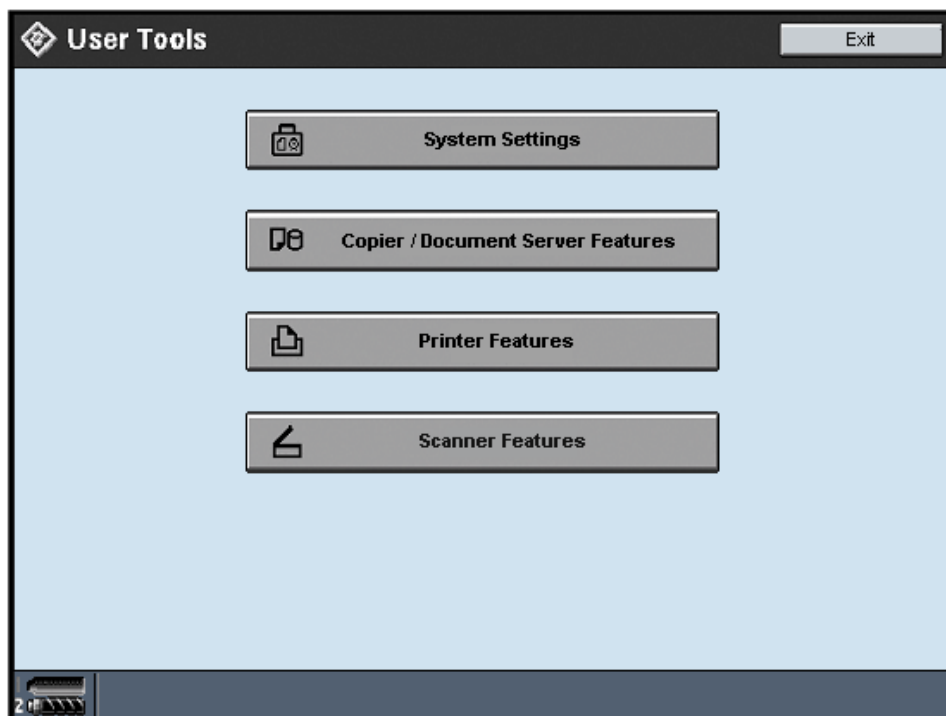

SECTION 4

INSTALLATION

4. INSTALLATION

4.1 INSTALLATION REQUIREMENTS

4.1.1 ENVIRONMENT

1. Temperature Range: 10°C to 32°C (50°F to 89.6°F)
2. Humidity Range: 15% to 80% RH

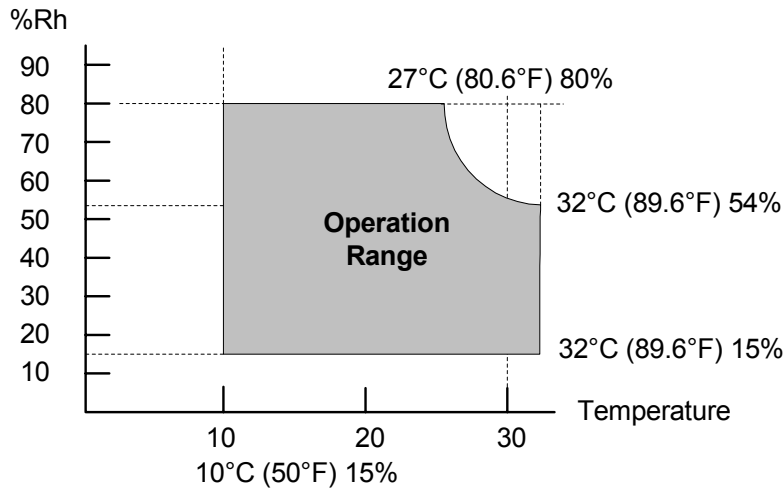

3. Ambient Illumination: Less than 1,500 lux (do not expose to direct sunlight or strong light)
4. Ventilation: Room air should turn over at least 3 times per hour
5. Ambient Dust: Less than 0.075 mg/m³
6. If the place of installation is air-conditioned or heated, do not place the machine where it will be:
 - 1) Subjected to sudden temperature changes
 - 2) Directly exposed to cool air from an air-conditioner
 - 3) Directly exposed to heat from a heater
7. Do not place the machine where it will be exposed to corrosive gases.
8. Do not install the machine at any location over 2,000 m (6,500 feet) above sea level.

9. Place the copier on a strong and level base.
10. Do not place the machine where it may be subjected to strong vibrations.
11. Do not connect the machine to a power source shared with another electrical appliance.
12. The machine can generate an electrical field which could interfere with radio or television reception.

4.1.2 MACHINE LEVEL

1. Front to back: Within 5 mm (0.2") of level
2. Right to left: Within 5 mm (0.2") of level

NOTE: The machine legs may be raised or lowered in order to level the machine. Set a carpenter's level on the exposure glass.

4.1.3 MINIMUM SPACE REQUIREMENTS

Place the copier near the power source, providing clearance as shown below. The same amount of clearance is necessary when optional equipment is installed.

Copier + Finisher + LCT + By-pass Tray

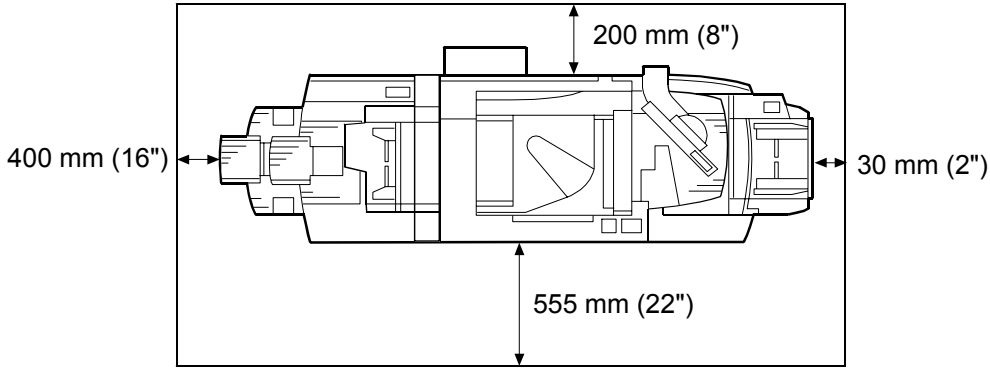

Copier + Finisher

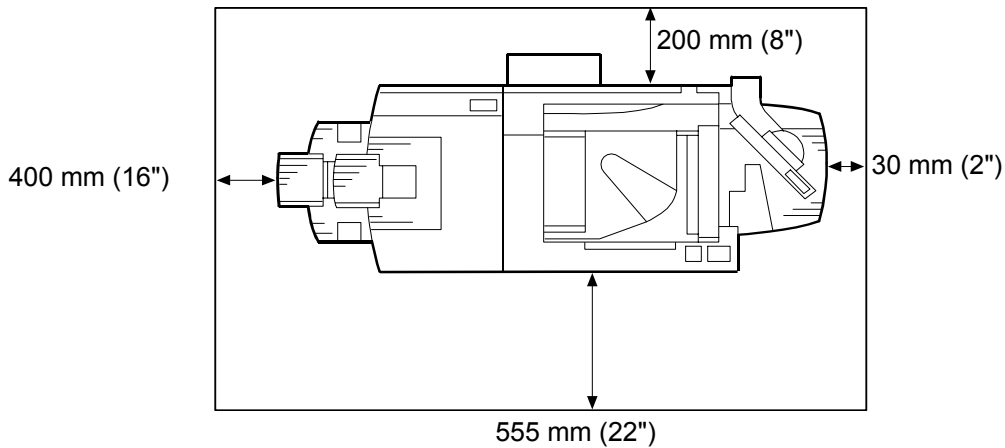

NOTE: The controller box door on the back of the machine swings open and can be removed. Door removal is required only if the machine cannot pass through a narrow door.

4.1.4 DIMENSIONS

Side View

Unit: mm/inch

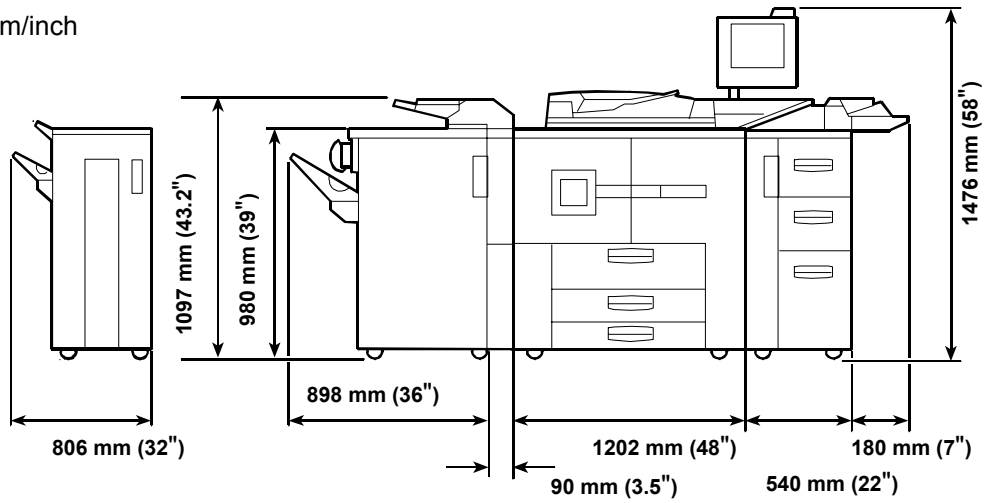

Top View

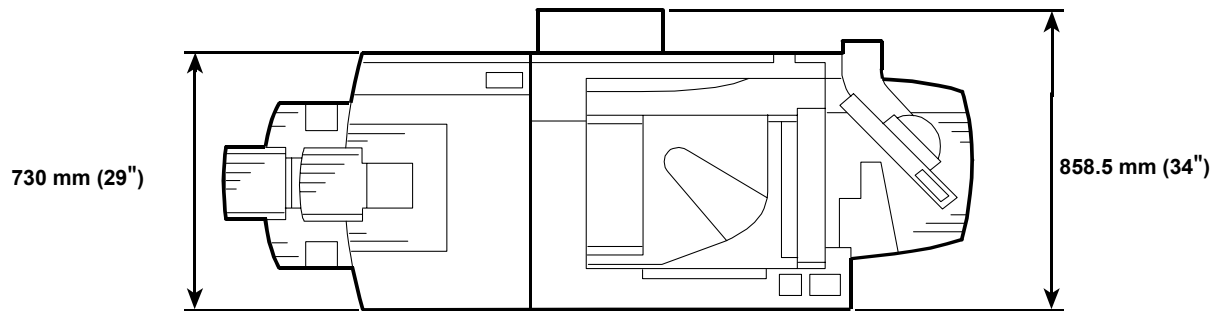

4.1.5 POWER REQUIREMENTS

CAUTION

1. Make sure that the wall outlet is near the main machine and easily accessible. Make sure the plug is firmly inserted in the outlet.
2. Avoid multi-wiring.
3. Be sure to ground the machine.
4. Never set anything on the power cord.

Input voltage level:

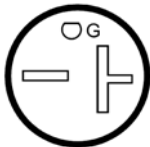

NEMA 6-20R

North America:

208 to 240 V, 60 Hz: More than 20 A

Europe/Asia:

220 ~240 V, 50/60 Hz: More than 16 A

Note: For USA installations, standard 220V (+/-10%) wall voltage is acceptable.

CAUTION

Never turn off the main power switch when the power LED is lit or flashing. To avoid damaging the hard disk or memory, press the operation power switch to switch the power off, wait for the power LED to go off, and then switch the main power switch off.

The Main Power LED () lights or flashes at the following times:

- While the platen cover or ADF is open
- While the main machine is communicating with the network server
- While the machine is accessing the hard disk or memory when reading or writing data.

There are two power switches on the machine:

- **Main Power Switch.**
Located on the front left corner of the machine and covered by a plastic cover. This switch should always remain on unless the machine is being serviced.
- **Operation Power Switch.**
Located on the right side of the operation panel. This is the switch normally used by the customer to power the machine on and off.

4.2 COPIER (B070/B071)

4.2.1 ACCESSORIES

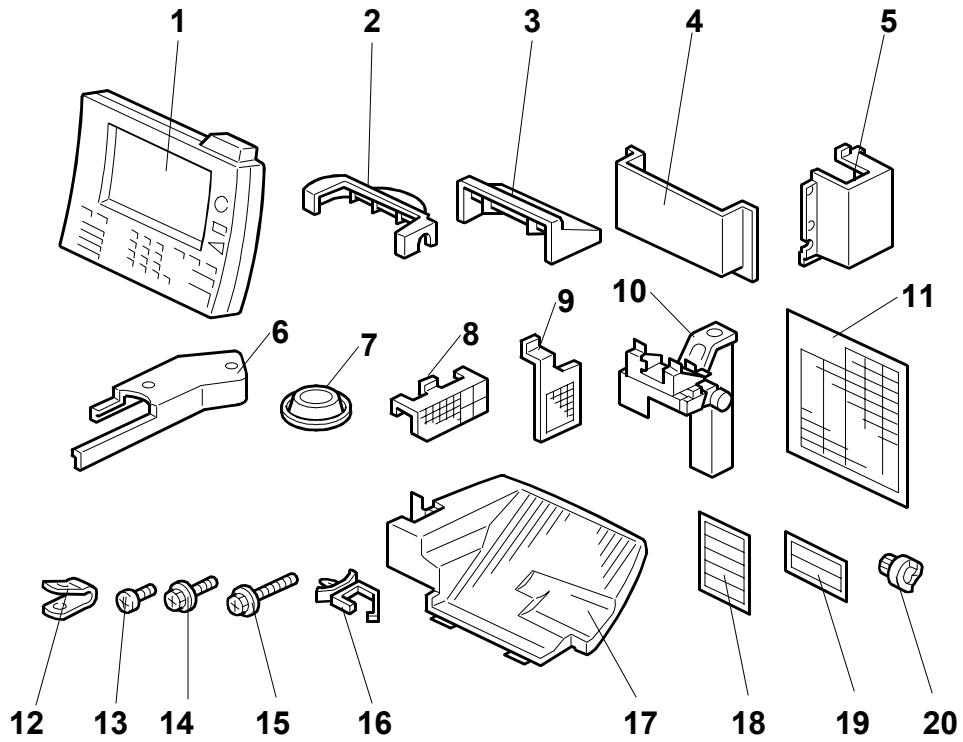

Check the quantity and condition of the accessories in the box against the following list:

Description	Q'ty
1. Operation Panel.....	1
2. Lower Cover - Operation Unit Holder.....	1
3. Upper Cover - Operation Unit Holder.....	1
4. Operating Instruction Holder.....	1
5. Right Arm Cover	1
6. Operation Unit Arm.....	1
7. Leveling Shoes	4
8. Optics Dust Filter	1
9. Dust Filter	1
10. Operation Panel Unit Arm.....	1
11. Paper Size Decals	1
12. Metal Cable Clamp	1
13. Tapping Screw - M4 x 12.....	2
14. Philips Pan Head Screw - M4 x 6	1
15. Tapping Screw - M4 x 8.....	25
16. Nylon Harness Clamp.....	1
17. ADF Exit Tray	1
18. Paper Size Decals	1
19. Paper Loading Decals	1
20. Toner Hopper Drive Gear (White).....	1
Model Name Plate (-10, -15, -22 machines) – not shown.....	1
Operating Instructions – not shown	1

SECTION 5

LARGE CAPACITY TRAY

5. OVERALL MACHINE INFORMATION

5.1 SPECIFICATIONS

Paper Weight	Tray 4, 5	52 to 216 g/m ²
	Tray 6	52 to 216 g/m ²
Paper Size	Tray 4,5,6	A4 LEF, B5 LEF, 8 1/2"x11" LEF, A5, 5 1/2"x8 1/2"
Tray Capacity:	Tray 4, 5	1,000 sheets (Thick Paper 0.11 mm)
	Tray 6	2,550 sheets (Thick Paper 0.11 mm)
Tab Sheet:	Feed possible from Tray 4 or Tray 5. Requires installation of tab sheet fence. Note: Only A4 LEF, 8 1/2" x 11" LEF tab sheets can be fed.	
Paper Feed System:	FRR	
Remaining Paper Detection:	5-Step including Near-End for Trays 4, 5, 6	
Power Source:	24 Vdc, 5 Vdc (from copier)	
Power Consumption:	55 W	
Weight:	Less than 82 kg (180.4 lb.)	
Size (W x D x H):	540 mm x 730 mm x 980 mm (21.3" x 28.7" x 38.6")	

5.2 OVERALL MECHANICAL INFORMATION

5.2.1 MECHANICAL COMPONENT LAYOUT

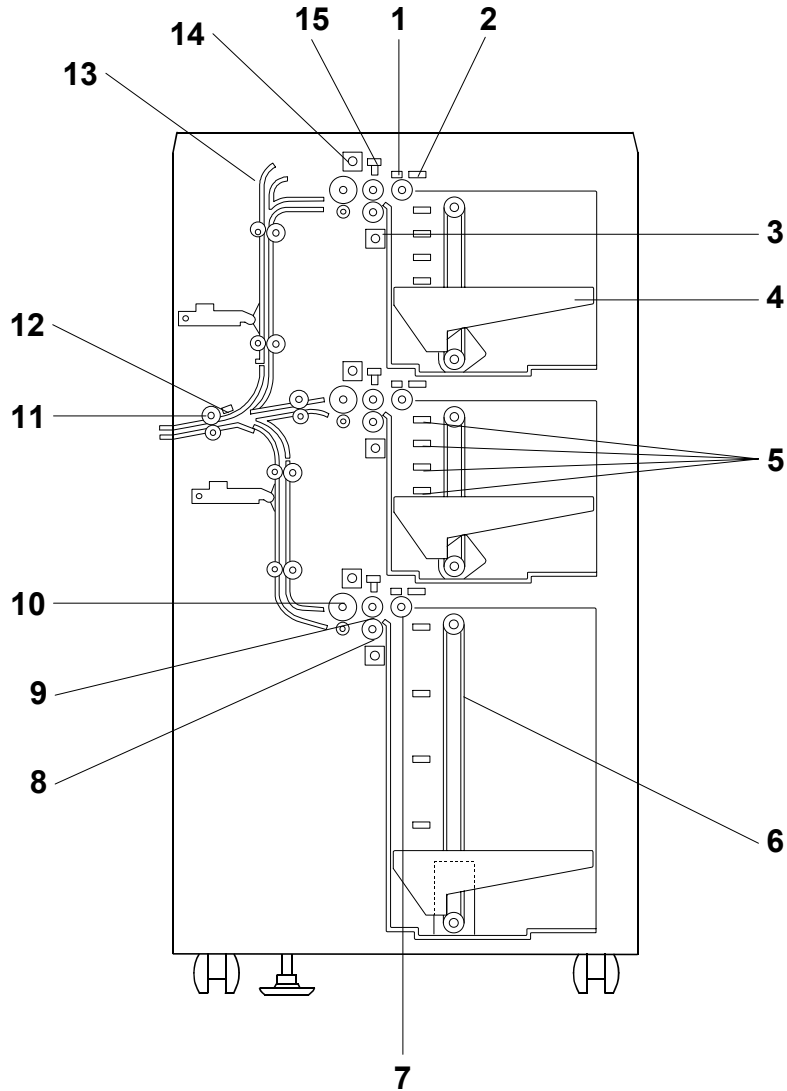

- | | |
|-------------------------|-----------------------------|
| 1. Paper Feed Sensor | 9. Paper Feed Roller |
| 2. Paper End Sensor | 10. Grip Roller |
| 3. Separation Solenoid | 11. Relay Roller |
| 4. Paper Tray | 12. Relay Sensor |
| 5. Paper Height Sensors | 13. Feed Slot (Bypass Tray) |
| 6. Tray Drive Belt | 14. Pick-up Solenoid |
| 7. Pick-up Roller | 15. Lift Sensor |
| 8. Separation Roller | |

5.3 ELECTRICAL COMPONENT DESCRIPTIONS

Symbol	Name	Function
Clutches		
MC1	Transport	Drives the transport rollers in the LCT.
MC2	1st Paper Feed	Drives the paper feed roller in the 1st tray.
MC3	1st Grip	Drives the grip roller in the 1st tray.
MC4	2nd Paper Feed	Drives the paper feed roller in the 2nd tray.
MC5	2nd Grip	Drives the grip roller in the 2nd tray.
MC6	3rd Paper Feed	Drives the paper feed roller in the 3rd tray.
MC7	3rd Grip	Drives the grip roller in the 3rd tray
Motors		
M1	LCT	Drives all rollers in the LCT.
M2	1st Lift	Drives the 1st tray up and down.
M3	2nd Lift	Drives the 2nd tray up and down.
M4	3rd Lift	Drives the 3rd tray up and down.
PCB		
PCB1	LCT Control Board	Controls the LCT and communicates with the copier.
Sensors		
SN1	1st Paper Height 1	Detects the paper height in the 1st tray.
SN2	1st Paper Height 2	Detects the paper height in the 1st tray.
SN3	1st Paper Height 3	Detects the paper height in the 1st tray.
SN4	1st Paper Height 4	Detects the paper height in the 1st tray.
SN5	2nd Paper Height 1	Detects the paper height in the 2nd tray.
SN6	2nd Paper Height 2	Detects the paper height in the 2nd tray.
SN7	2nd Paper Height 3	Detects the paper height in the 2nd tray.
SN8	2nd Paper Height 4	Detects the paper height in the 2nd tray.
SN9	3rd Paper Height 1	Detects the paper height in the 3rd tray.
SN10	3rd Paper Height 2	Detects the paper height in the 3rd tray.
SN11	3rd Paper Height 3	Detects the paper height in the 3rd tray.
SN12	3rd Paper Height 4	Detects the paper height in the 3rd tray.
SN13	Exit	Checks for the presence of paper (misfeeds) at the LCT exit.
SN14	1st Paper Feed	Detects the copy paper coming to the 1st paper feed roller and checks for misfeeds.
SN15	1st Paper End	Informs the copier when the paper in the 1st tray has run out.
SN16	1st Lift	Detects when the paper in the 1st tray is at the correct paper feed height.
SN17	2nd Paper Feed	Detects the copy paper coming to the 2nd paper feed roller and checks for misfeeds.
SN18	2nd Paper End	Informs the copier when the paper in the 2nd tray has run out.
SN19	2nd Lift	Detects when the paper in the 2nd tray is at the correct paper feed height.
SN20	3rd Paper Feed	Detects the copy paper coming to the 3rd paper feed roller and checks for misfeeds.

Symbol	Name	Function
SN21	3rd Paper End	Informs the copier when the paper in the 3rd tray has run out.
SN22	3rd Lift	Detects when the paper in the 3rd tray is at the correct paper feed height.
Solenoids		
SOL1	1st Separation	Controls up-down movement of the separation roller in the 1st tray.
SOL2	2nd Separation	Controls up-down movement of the separation roller in the 2nd tray.
SOL3	3rd Separation	Controls up-down movement of the separation roller in the 3rd tray.
SOL4	1st Pick-up	Controls up-down movement of the pick-up roller in the 1st tray.
SOL5	2nd Pick-up	Controls up-down movement of the pick-up roller in the 2nd tray.
SOL6	3rd Pick-up	Controls up-down movement of the pick-up roller in the 3rd tray.
Switches		
SW1	Front Door Safety	Detects whether the tray cover is opened or not.
SW2	1st Paper Size	Detects the paper size in the 1st tray, and whether the 1st tray is in the machine.
SW3	2nd Paper Size	Detects the paper size in the 2nd tray, and whether the 2nd tray is in the machine.
SW4	3rd Paper Size	Detects whether the 3rd tray is in the machine. The paper size must be input with a user tool.

5.4 DRIVE LAYOUT

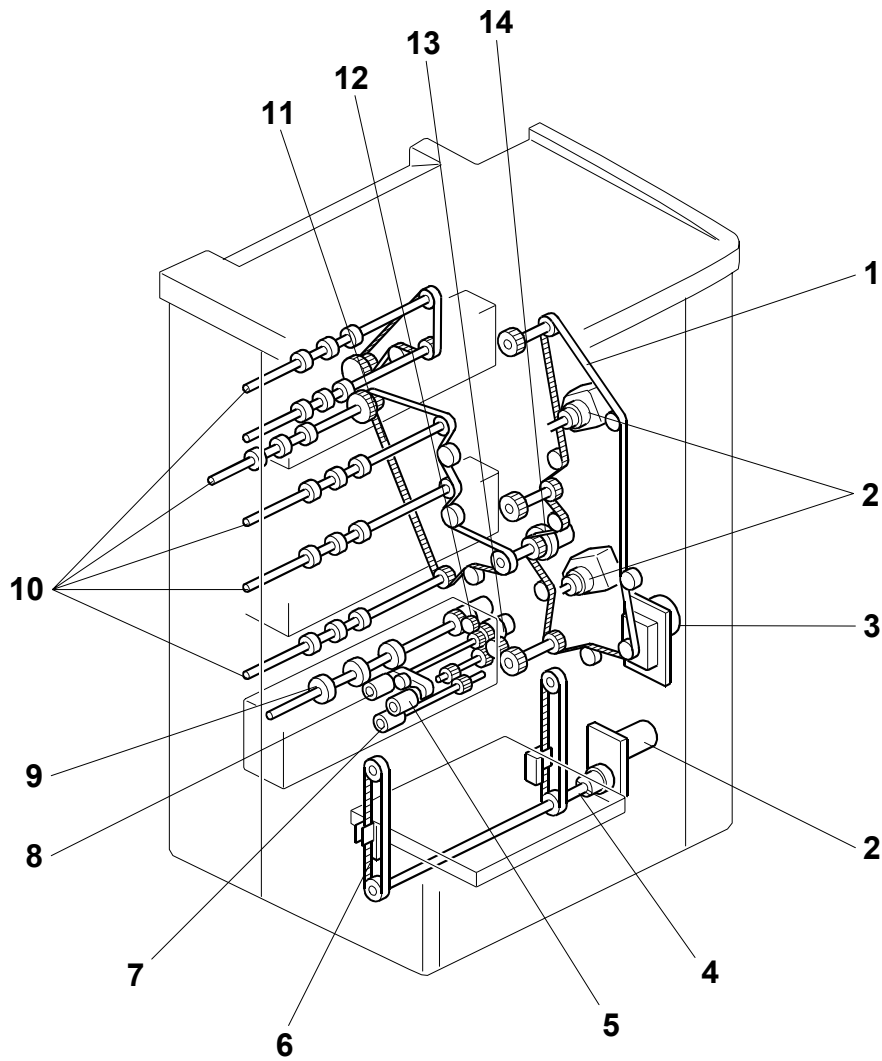

- | | |
|----------------------|---------------------------------|
| 1. Main Drive Belt | 8. Paper Feed Roller |
| 2. Tray Lift Motors | 9. Grip Roller |
| 3. LCT Motor | 10. Transport Rollers |
| 4. Tray Drive Shaft | 11. Transport Roller Drive Belt |
| 5. Pick-up Roller | 12. Grip Roller Clutch |
| 6. Tray Drive Belt | 13. Paper Feed Clutch |
| 7. Separation Roller | 14. Transport Clutch |

5.5 DETAILED DESCRIPTIONS

5.5.1 PAPER FEED

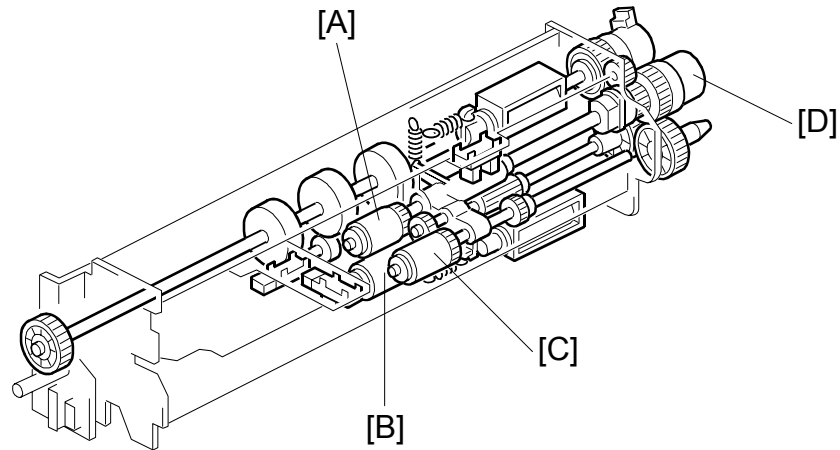

This LCT has three paper tray feed stations.

The upper and middle trays can each hold 1,000 sheets of paper. The lower tray can hold 2,550 sheets of paper.

All feed stations use an FRR paper feed system (paper feed roller [A], separation roller [B], pick-up roller [C]), and those rollers are driven by the LCT motor via the paper feed clutch [D].

5.5.2 PICK-UP AND FEED

Overview

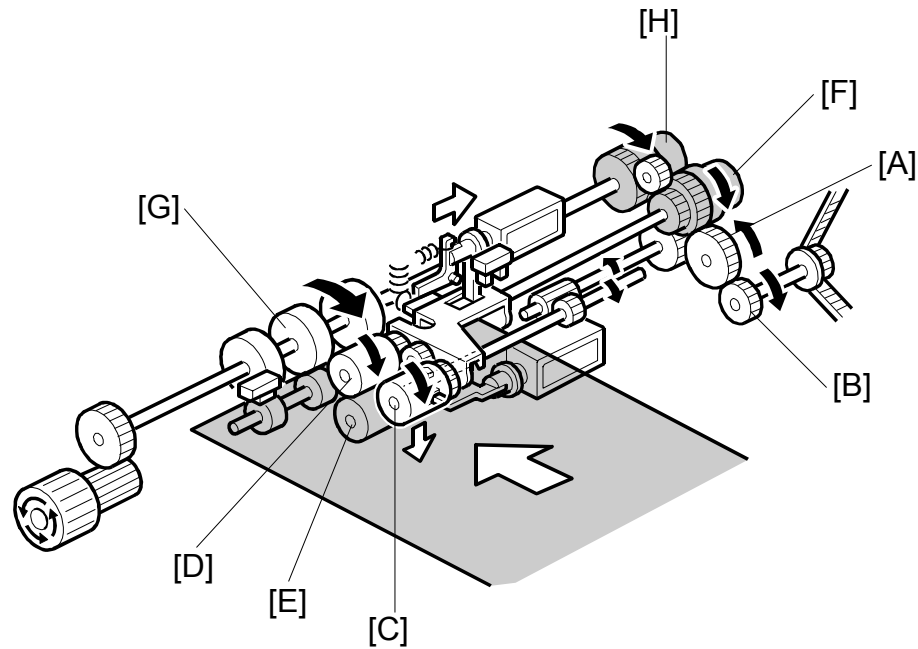

Drive from the LCT motor is transmitted to the gear [A] in the paper feed unit via the timing belt [B].

Then the gear [A] transmits the drive to the pick-up [C], paper feed [D], and separation [E] rollers via gears and the paper feed clutch [F].

The gear [A] also transmits the drive to the grip roller [G] via gears and the grip roller clutch [H].

5.5.3 PICK-UP AND FEED

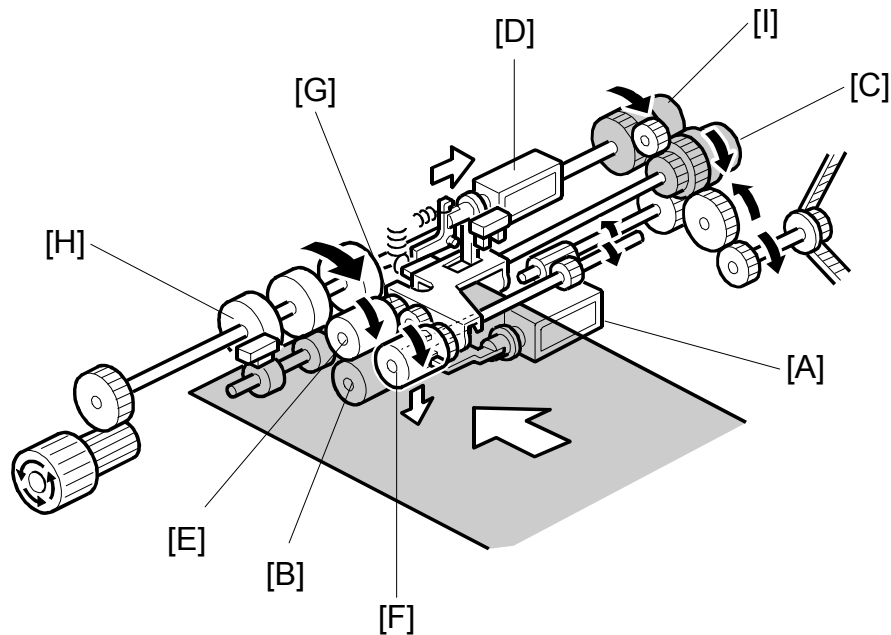

When a paper feed station is not selected, its separation roller solenoid [A] is deactivated and the separation roller [B] can turn freely.

When the paper feed station is selected and the Start key is pressed, the feed clutch [C], separation roller solenoid [A], and pick-up solenoid [D] turn on.

When the feed clutch [C] actuates, it drives the feed roller [E], and turns the pick-up roller [F] because it is linked to the feed roller by an idle gear [G].

When the separation roller solenoid [A] turns on, the separation roller [B] contacts the paper feed roller [E] and turns with the feed roller, unless more than one sheet of paper is fed. The three trays of the LCT unit use the standard FRR mechanism.

☛ **Handling Paper > Paper Feed Methods > Forward and Reverse Roller (FRR)**

When the pick-up solenoid [D] actuates, the pick-up roller [F] lowers until it contacts the top sheet of the paper stack and then sends it to the paper feed and separation roller.

When the paper feed sensor [H] detects the leading edge of the paper, the pick-up solenoid de-actuates and lifts the pick-up roller [F], and the grip roller clutch [I] actuates and feeds the paper out of the tray.

5.5.4 SEPARATION ROLLER RELEASE

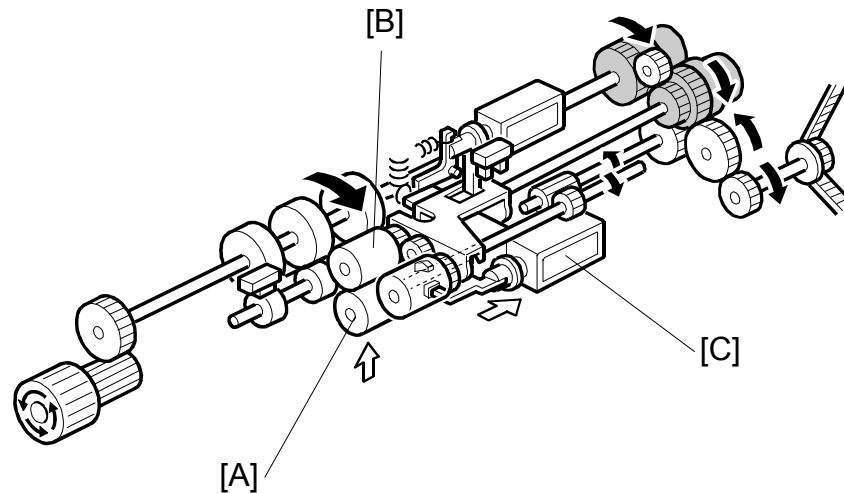

The separation roller [A] is normally away from the feed roller [B]. When the paper feed station is selected, the separation roller solenoid [C] contacts the separation roller with the feed roller as explained on the previous two pages.

This contact/release mechanism has the following three advantages:

1. When the LCT motor turns on, all the separation rollers in the three feed stations rotate. If the separation roller is away from the feed roller, it reduces the load on the paper feed motor and drive mechanism, and it also reduces wear to the rubber surface of the separation roller caused by friction between the separation roller and the feed roller.
2. After paper feed is completed, paper sometimes remains between the feed and separation rollers. If the feed tray is removed at this time, this paper might be torn. When the separation roller is away from the feed roller, the remaining paper can be removed from between the rollers.
3. When paper misfeeds occur around this area, the user can easily pull out the jammed paper between the feed and the separation rollers if the separation roller is away from the feed roller.

After paper feed, the paper feed clutch turns off, but the LCT motor still turns the separation roller [A] in reverse. The separation roller, still contacting the feed roller, turns the feed roller in reverse for 100 ms. Then the separation solenoid turns off.

5.6 PAPER LIFT

5.6.1 TRAY DETECTION

When a tray is set in the machine, the tray detection method used depends on the tray:

- The upper tray and middle tray are detected when any one of the paper size switch signals is low.
- The lower tray is detected when the switch 1 signal of the paper size switch is low.

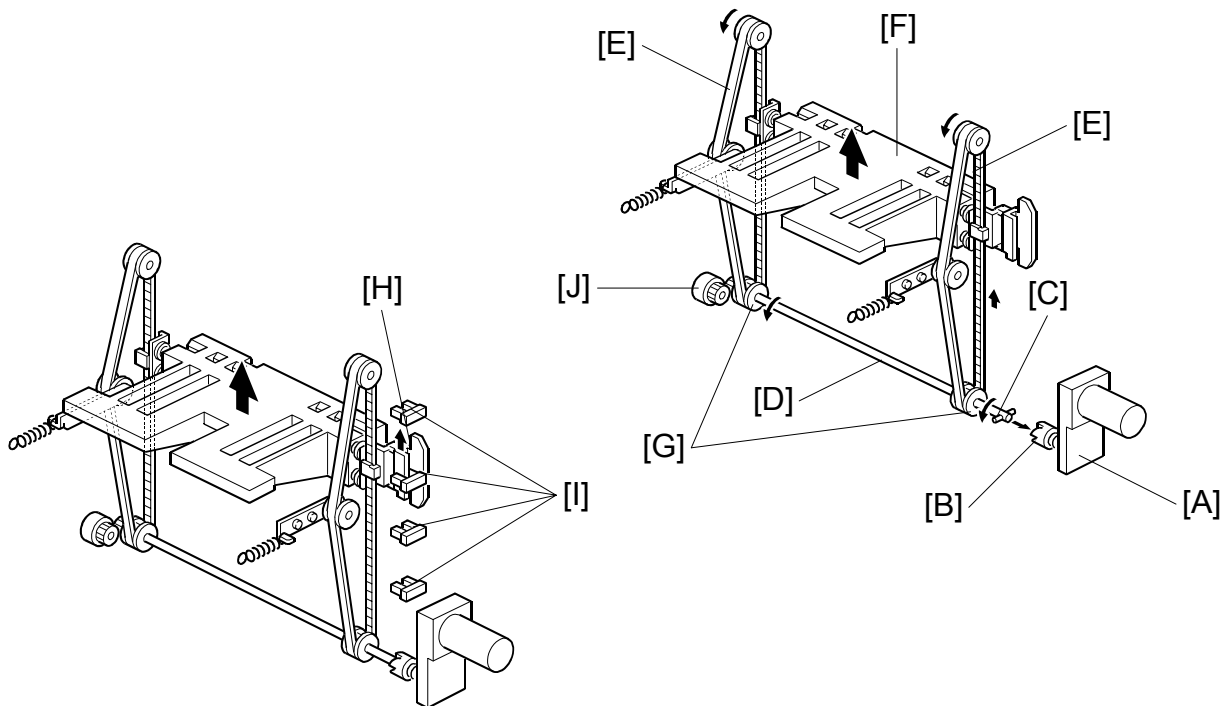

5.6.2 LIFT MECHANISM

When the machine detects that the paper tray is set in the machine, the tray lift motor [A] rotates and the coupling gear [B] on the tray lift motor engages the pin [C] of the lift drive shaft [D]. The tray drive belts [E] are connected to the tray bottom plate [F] and are driven by the tray lift motor via the lift drive shaft [D] and tray drive pulleys [G]. When the lift motor turns counterclockwise, the tray bottom plate [F] moves up. The tray goes up until the top of the paper stack pushes up the pick-up roller and the lift sensor in the feed unit is de-activated.

When the actuator [H] on the rear end of the bottom plate activates the paper height sensors [I], the remaining paper capacity is detected.

When pulling out the tray, the coupling gear [B] separates from the pin [C], so that the tray bottom plate moves downward. In the bottom tray, the damper [J] lets the tray bottom plate drop slowly.

5.6.3 LIFT SENSOR

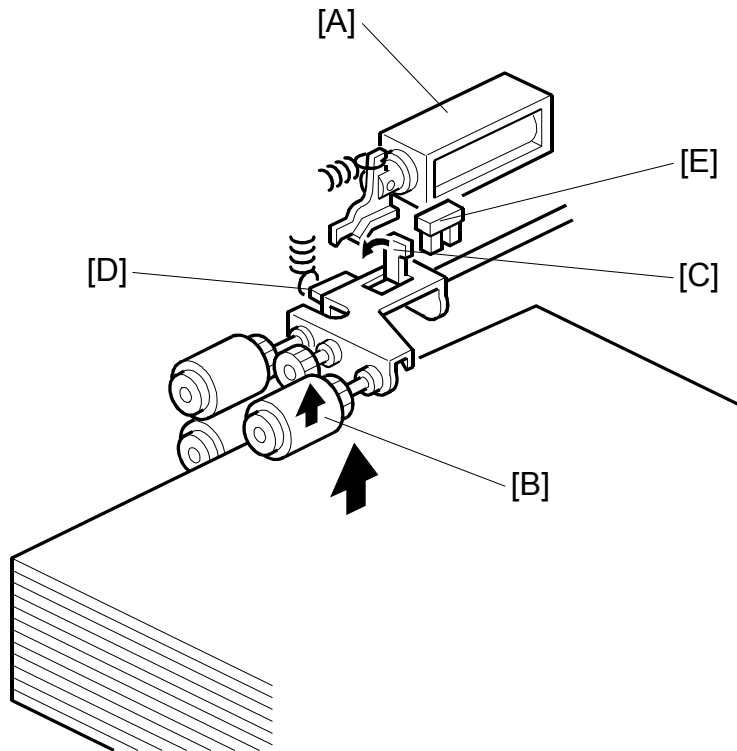

When the lift motor turns on, the pick-up solenoid [A] activates to lower the pick-up roller [B]. When the top sheet of paper reaches the proper paper feed level, the paper pushes up the pick-up roller and the actuator [C] on the pick-up roller supporter [D] de-activates the lift sensor [E] to stop the lift motor.

After several paper feeds, the paper level gradually lowers, then the lift sensor is activated and the lift motor turns on again until the lift sensor is de-activated again.

5.7 PAPER SIZE DETECTION

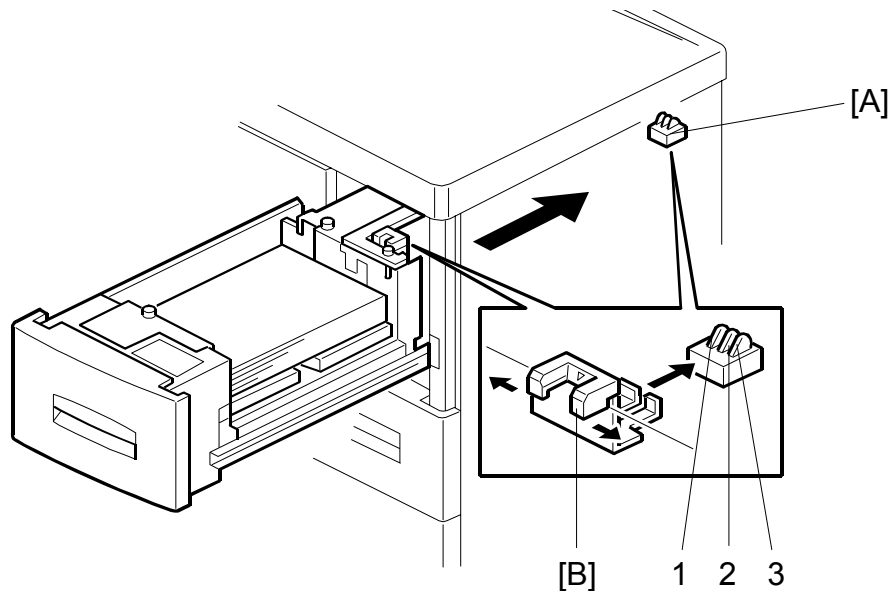

	A4-LEF	B5-LEF	A5-LEF	A5-SEF	LT-LEF	HLT-LEF	HTL-SEF
SW1	0	1	0	0	0	1	1
SW2	1	0	1	0	0	0	1
SW3	1	1	0	1	0	0	0

1: HI 0: LOW

Top Tray (Tray 1) and Middle Tray (Tray 2)

For the top and middle trays, the paper size switch [A] detects the paper size. The paper size switch contains three microswitches. The paper size switch is actuated by an actuator plate [B] at the rear of the tray. Each paper size has its own unique combination as shown in the table and the CPU determines the paper size by the combination.

Bottom Tray (Tray 3)

The bottom tray has the same switch as the top and middle trays. However, it is only used for detecting when the tray is pushed in.

For the bottom tray, the paper size must be selected in the SP5019-007:

5.8 REMAINING PAPER DETECTION

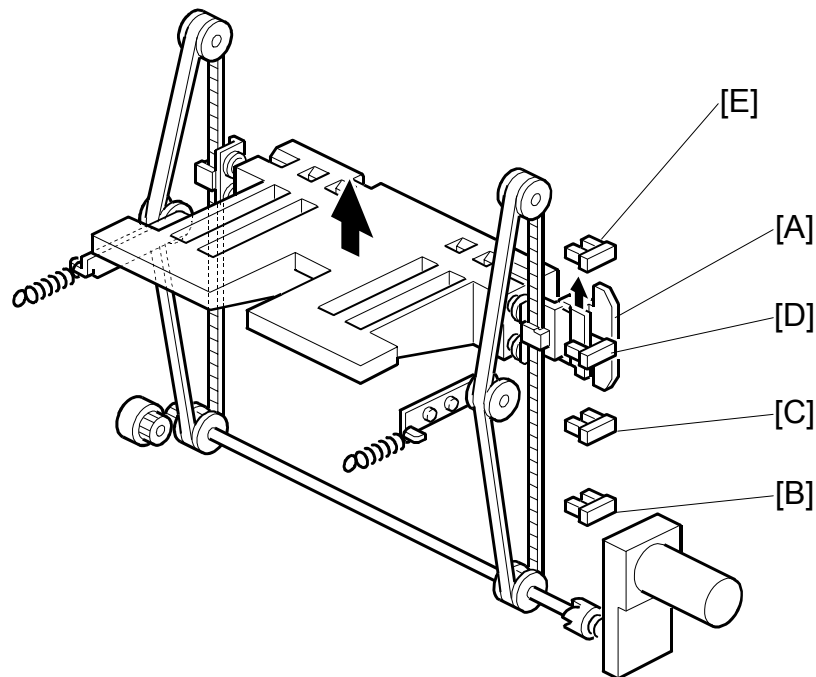

The amount of paper remaining in the tray is detected by the three paper height photointerrupter sensors on the left rail as the bottom plate rises. Five states, determined by the position of the actuator are possible.

1. With the actuator [A] below paper height sensor 1 [B], no sensor is actuated and the display indicates 100%.
2. When the actuator passes paper height sensor 1 [B], the display indicates 75% of the paper supply remaining.
3. When the actuator passes paper height sensor 2 [C], the display indicates 50% of the paper supply remaining.
4. When the actuator passes paper height sensor 3 [D], the display indicates 25% of the paper supply remaining.
When the actuator enters the gap of the near end sensor [E], the machine signals near end.

Finally, when the last sheet feeds, the paper end sensor signals that the tray is empty.

5.9 PAPER END DETECTION

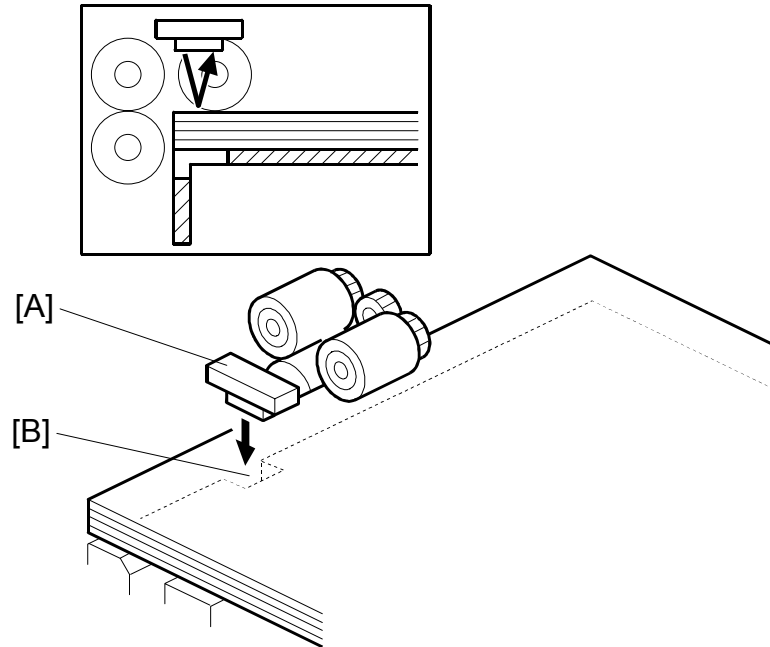

The paper end sensor [A] detects the top sheet of the paper in the tray by monitoring the reflected light. When the paper tray runs out of paper, the paper end sensor does not receive the reflected light due to the cutout [B]. Then, the tray lift motor rotates backwards 2 seconds to drop the tray bottom plate.

SECTION 6

SR860 BOOKLET FINISHER

6. OVERALL MACHINE INFORMATION

6.1 SR860 3000 SHEET BOOKLET FINISHER (B468)

NOTE: The 3000 Sheet Booklet Finisher B468 is used with the B070 (90 ppm)

Upper Tray

Tray Capacity (80 g/m ²)	Unstapled	500 sheets (A4, A5 LEF, B5, 8 1/2"x11") 250 sheets (A3 SEF, B4 SEF, 11"x17" SEF, 8 1/2"x11", 12"x18") 100 sheets (A5 SEF, A6 SEF, B6 SEF, 5 1/2"x8 1/2")		
	Stapled	Max docs.	Total sheets	Size
		50 docs.	500 sheets	A4 LEF, 8 1/2"x11" LEF
		25 docs.	250 sheets	A3, A4 SEF, B4, B5, 12"x18", 11"x17", 8 1/2"x11"
Stapled (Mixed Sizes)	16 docs	30 sheets	A3 LEF, A4 LEF, B4 LEF, B5 LEF, 11"x17" LEF, 8 1/2"x11" LEF	
Paper Size	A3 ~ A5, A6 SEF, B6 SEF, 12"x18", 11"x17" ~ 5 1/2"x8 1/2"			
Paper Weight	52 g/m ² ~ 216 g/m ²			

Lower Tray

Documents selected for booklet finishing (saddle-stitching) are folded, stapled, and output only to the lower tray.

Tray Capacity (80 g/m ²)	Unstapled	2,500 Sheets	A4 LEF, 8 1/2"x11" LEF	
		1,250 Sheets	A3 SEF, A4 SEF, B4 SEF, B5, 11"x17" SEF, 8 1/2"x14", 8 1/2"x11" SEF, 12"x18"	
		500 Sheets	A5 LEF	
		100 Sheets	A5 SEF, B6 SEF, 5 1/2"x8 1/2"	
	Stapled	Max docs.	Total sheets	Size
		50 docs.	2,500 sheets	A4 LEF, 8 1/2"x11" LEF
		50 docs.	1,250 sheets	A4 SEF, B5, 8 1/2"x11" SEF
		30 docs.	1,250 sheets	A3, B4, 12"x18", 11"x17"
	Stapled (Mixed Sizes)	50 docs.	30 sheets	A3 LEF, A4 LEF, B4 LEF, B5 LEF, 11"x17" LEF, 8 1/2"x11" LEF.
	Paper Size	A3 ~ A5, A6 SEF, B6 SEF, 12"x18", 11"x17" ~ 5 1/2"x8 1/2" LEF		
Paper Weight	52 g/m ² ~ 216 g/m ²			

Proof Tray

Tray Capacity	250 sheets (A4, 8 1/2"x11" or smaller) 50 sheets (B4, 8 1/2"x14" or larger)
Paper Weight	52 g/m ² ~ 216 g/m ²

Staple Specifications

Binding Capacity (80 g/m ²)	Same Size	50 sheets (A4, 8 1/2" x 11" or smaller) 30 sheets (B4, 8 1/2" x 14" or larger)
	Mixed Sizes	30 sheets (A3 and A4 LEF, B4 and B5 LEF, 11" x 17" and 8 1/2" x 11" LEF)
Paper Size	A3 to B5, 11" x 17" to 8 1/2" x 11"	
Paper Weight	64 g/m ² to 90 g/m ²	
Stapling Position	Front (1), Back (1), Back (1: diagonal), 2 positions	
Stapling Capacity	5,000 staples/cartridge	

Booklet Staple Specifications

Binding Capacity (80 g/m ²)	15 Sheets		
Paper Size	A3 SEF, B4 SEF, A4 SEF, 11" x 17" SEF, 8 1/2" x 11" SEF		
Paper Weight	64 g/m ² ~ 90 g/m ²		
Stapling Position	Center, 2 Locations		
Stapling Capacity	2,000 Staples/Cartridge		
Fold Position	Center, Half-Folding		
Saddle-Stitch Capacity	Max. Docs.	Total Sheets	Size
	25	2~5	A4 SEF, 8 1/2" x 11" SEF
	15	6~10	
	10	11~15	
	30	2~5	A3 SEF, B4 SEF, 11" x 17" SEF
	20	6~10	
	10	11~15	

6.2 PUNCH UNIT (B377)

The Punch Unit B377 is installed in the 3000 Sheet Booklet Finisher B468 connected to the B070 (90 ppm).

Punch Position	North America (NA)	2/3 holes	B377-17
	Europe (E)	2/4 holes	B377-27
	Northern Europe (NE)	4 holes	B377-31
Punching Allowed	All modes		
Allowed Paper Sizes	Holes	Feed	Paper Size
	2-hole (EUR/A)	SEF	A3 ~ A5, 11" x 17" ~ 5 1/2" x 8 1/2"
		LEF	A4 ~ A5, 8 1/2" x 11", 5 1/2" x 8 1/2"
	2-hole (NA)	SEF	A3 ~ A5, 11" x 17" ~ 5 1/2" x 8 1/2"
		LEF	A4 ~ A5, 8 1/2" x 11", 5 1/2" x 8 1/2"
	3-hole (NA)	SEF	A3, B4, 11" x 17"
		LEF	A4, B5, 8 1/2" x 11"
	4-holes (EUR/A)	SEF	A3, B4, 11x17"
LEF		A4, B5, 8 1/2" x 11"	
4-holes (North Europe)	SEF	A3 ~ A5, 11" x 17" ~ 5 1/2" x 8 1/2"	
	LEF	A3 ~ A5, 8 1/2" x 11", 5 1/2" x 8 1/2"	
Allowed Paper Weight	Holes	Weight	
	2-hole	52 ~ 163 g/m ² (14 ~ 43 lb.)	
	3-hole		
	4-hole (E)		
	4-hole (NE)		
2-hole (NA)			
Hopper Capacity	NA (2/3-hole)	More than 6 K prints	
	EUR/A (4-hole)	More than 8 K prints	
	EUR/A (2-hole)	More than 10 K prints	
Rated Voltage of Output Connector	Max. DC 24 V		
Dimensions (W x D x H)	700 x 620 x 960 mm (27.6" x 24.4" x 37.8")		
Weight	Approx. 65 kg (143 lb.) (With Finisher)		
Power Consumption	72 W (3 A/24 V)		
Power Supply	DC 24 V (From Copier to Finisher)		

6.3 OVERALL MECHANICAL INFORMATION

6.3.1 MECHANICAL COMPONENT LAYOUT

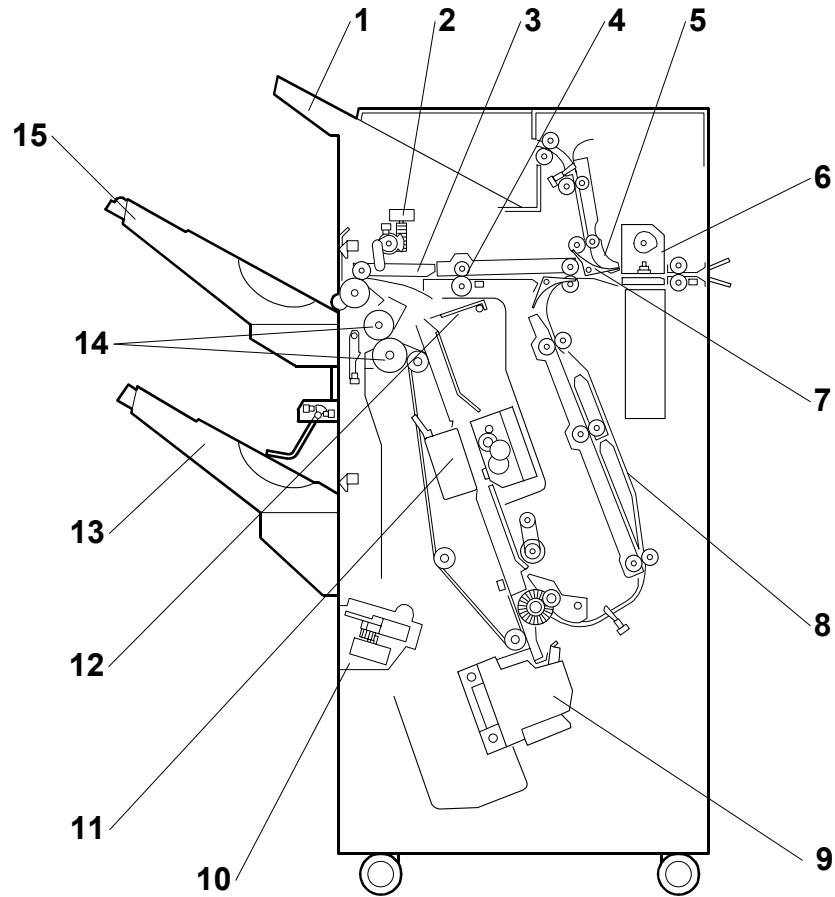

- | | |
|--------------------------|---------------------------|
| 1. Proof Tray | 9. Stapler Unit |
| 2. Guide Plate Motor | 10. Pressure Plate Unit |
| 3. Guide Plate | 11. Saddle Stitch Stapler |
| 4. Shift Roller | 12. Folder Plate |
| 5. Tray Junction Gate | 13. Lower Tray |
| 6. Punch Unit | 14. Folder Rollers |
| 7. Stapler Junction Gate | 15. Upper Tray |
| 8. Pre-Stack Tray | |

6.4 DRIVE LAYOUT

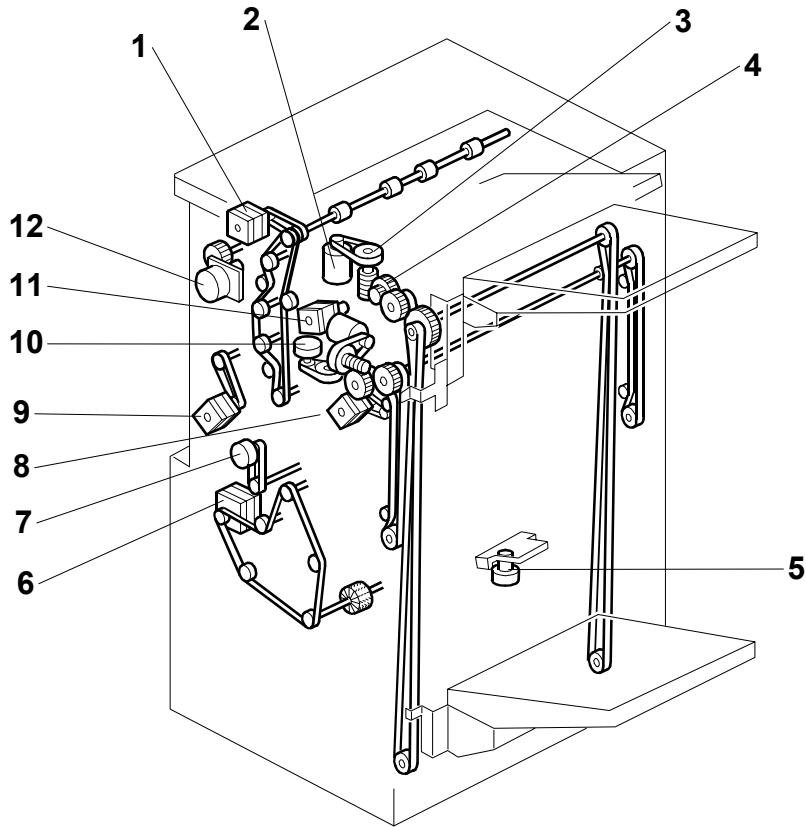

- | | |
|----------------------------|------------------------|
| 1. Proof Tray Motor | 7. Pre-Stack Motor |
| 2. Lower Tray Lift Motor | 8. Exit Motor |
| 3. Lower Tray Encoder Disk | 9. Entrance Motor |
| 4. Upper Tray Lift Motor | 10. Shift Roller Motor |
| 5. Pressure Plate Motor | 11. Shift Drive Motor |
| 6. Stapler Transport Motor | 12. Punch Motor |

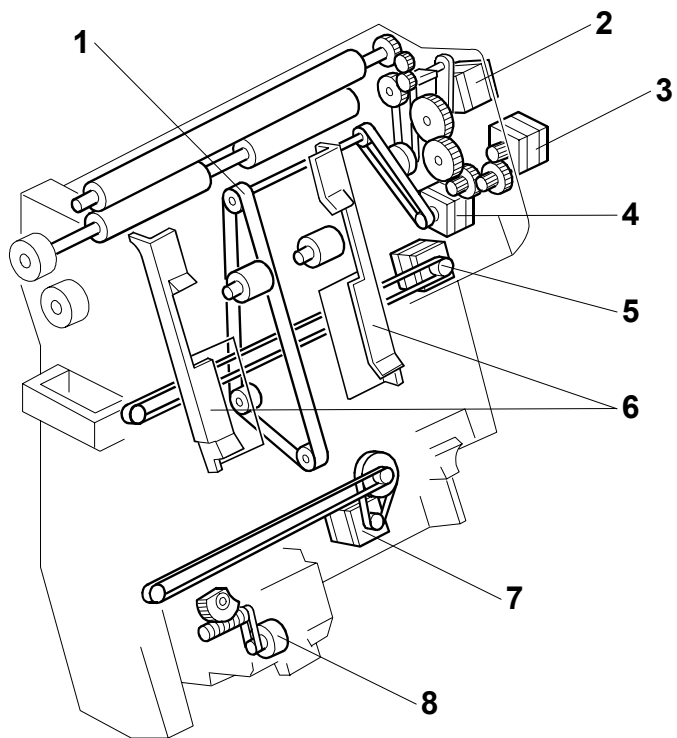

- | | |
|------------------------|---------------------------|
| 1. Stack Feed Out Belt | 5. Jogger Fence Motor |
| 2. Folder Roller Motor | 6. Jogger Fences |
| 3. Folder Plate Motor | 7. Stapler Movement Motor |
| 4. Feed Out Belt Motor | 8. Stapler Rotation Motor |

6.5 DETAILED DESCRIPTIONS

6.5.1 TRAY/STAPLER JUNCTION GATES

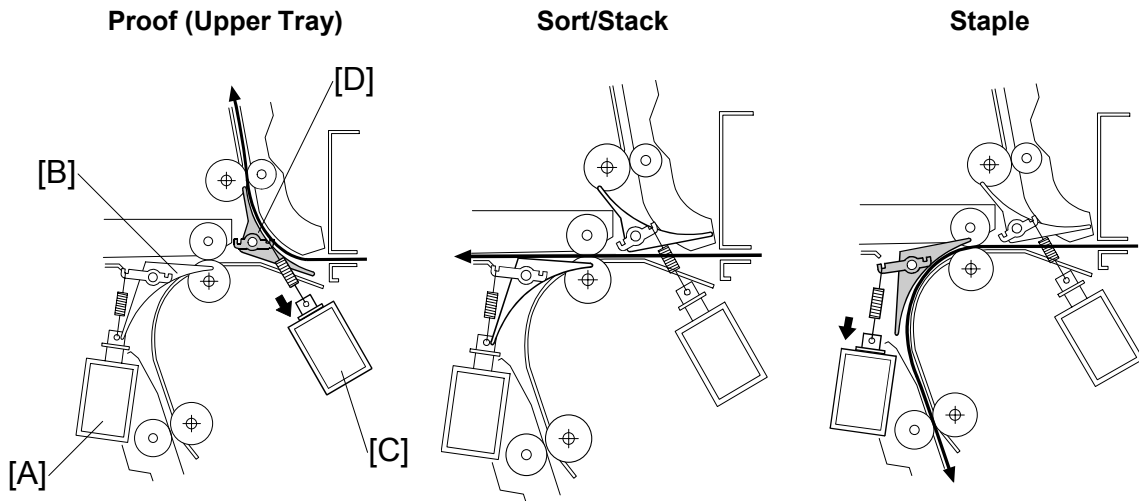

The finishing mode selected for the job determines the direction of the paper in the finisher.

- **Proof Tray (Top of the unit):** Paper is sent to the top tray.
- **Shift:** Paper is sent straight to the upper or lower tray.
- **Staple:** Paper is sent down to the stapler unit

Solenoid/Gate		Selected Operation Mode		
		Proof	Sort/Stack	Staple
[A]	Stapler junction gate solenoid	OFF	OFF	ON
[B]	Stapler junction gate	Closed	Closed	Open
[C]	Proof tray junction gate solenoid	ON	OFF	OFF
[D]	Proof tray junction gate	Open	Closed	Closed

6.5.2 PRE-STACKING

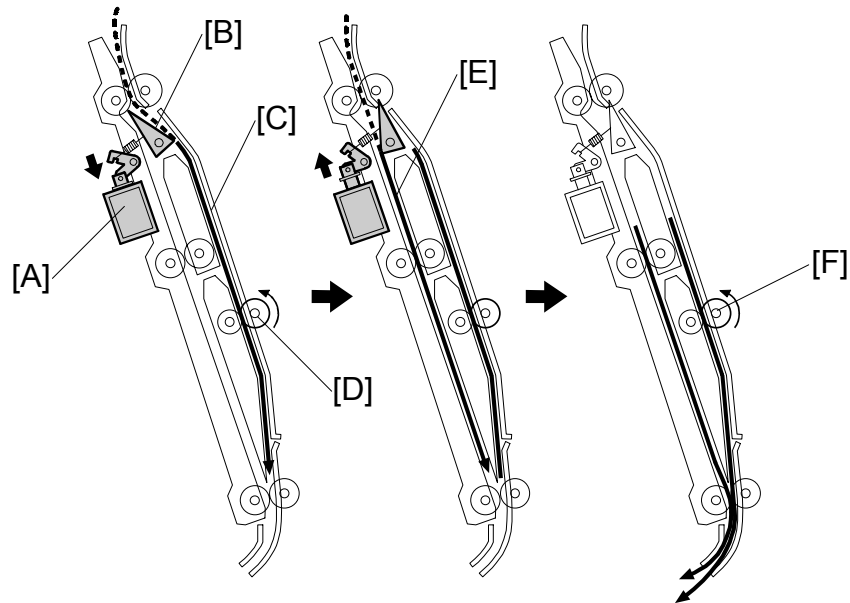

During a multiple copy job selected for stapling, the pre-stacking mechanism delays the first two sheets of every set (after the first set) to allow enough time to staple the preceding stack on the stapler tray. Pre-stacking is performed with the first and second sheets for the second and all subsequent sets.

Shortly after the first sheet of the set enters the finisher, the pre-stack junction gate solenoid [A] switches on, opens the pre-stack junction gate [B] and shunts the first sheet to the paper pre-stack tray [C]. When the first sheet passes the pre-stack roller [D], the pre-stack motor switches off and the sheet stops.

Shortly after the trailing edge of the first sheet enters the finisher, the solenoid switches off, and the junction gate closes. This allows the second sheet of the set to pass the closed junction gate and enter the main paper path [E].

At the prescribed time, the pre-stack motor switches on, and the pre-stack transport roller [F] rotates and sends the first sheet to the stapler tray at the same time as the second sheet arrives there.

All subsequent sheets of the same set are sent through the main paper path to the stapler tray for stapling.

6.5.3 VERTICAL LIFT MECHANISM

Overview

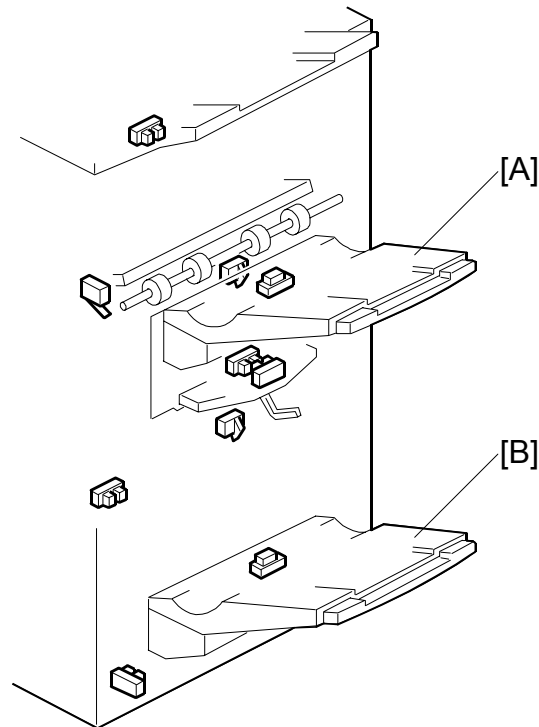

At power on, both trays lower slightly, then the upper tray stops at the feed-out position. The machine is ready for feed out to the upper tray [A]

During printing, the upper [A] or lower tray [B] (whichever is selected) is repeatedly lowered until the stack reaches a certain height and then the job halts. The upper tray holds 500 sheets (A4 LEF), and the lower tray holds 2500 sheets.

Both trays can be used for the normal, shift, and staple modes. However, only the lower tray can be used for the booklet binding (saddle-stitch mode).

6.5.4 UPPER TRAY

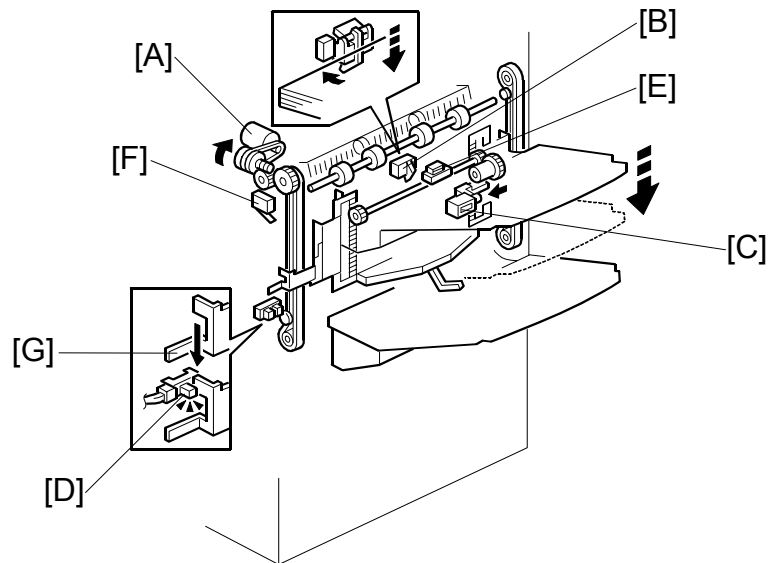

- [A]: Upper tray lift motor
- [B]: Upper tray paper height sensor
- [C]: Upper tray lift solenoid
- [D]: Upper tray full sensor
- [E]: Upper tray paper sensor
- [F]: Upper limit switch (upper tray)

Just After the Power is Switched on

At power on, the motor [A] moves the upper tray to the start position just under the feed-out slot. The motor stops when the paper height sensor [B] detects the tray.

Height Adjustment During Feed-Out

The upper tray moves up and down on a rack and pinion on a movable side fence that remains locked in place during copying.

When the top of the stack actuates the sensor [B], a solenoid [C] inside the upper tray releases a locked one-way clutch long enough to lower the upper tray a short distance on its track to allow more pages to feed out. This process repeats until the tray is full.

Upper Tray Full

When the tray is full, a metal actuator [G] on the side of the upper tray frame actuates the upper tray full sensor [D] and the job stops.

The paper sensor [E] inside the upper tray detects when the stack is removed from the tray, and the tray returns to the initial position at the feed-out slot. The upper limit switch [F] (a micro-switch) is a backup if sensor [B] fails to stop the tray.

6.5.5 LOWER TRAY

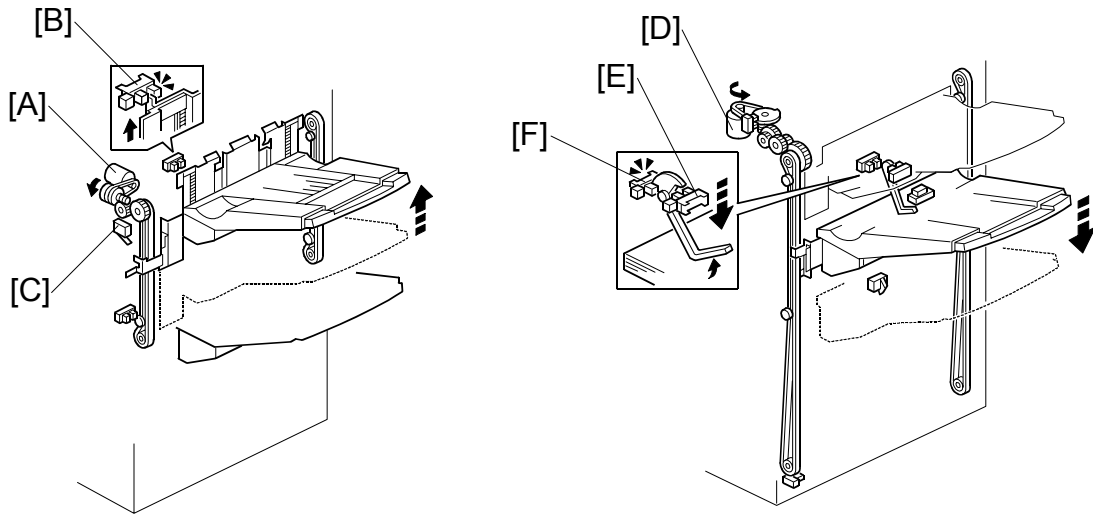

- [A]: Upper tray lift motor
- [B]: Upper tray upper limit sensor
- [C]: Upper limit switch (upper tray)
- [D]: Lower tray lift motor
- [E]: Lower tray paper height sensor 1
- [F]: Lower tray paper height sensor 2

Just After the Power is Switched on

At power on, the upper tray moves to the start position under the feed-out slot, as described previously.

Positioning the Lower Tray for Feed-out

If the lower tray is selected for a job, the upper tray is moved away from the feed-out slot at the start of the job. The motor [A] lifts the side fence and upper tray to upper limit sensor [B], which stops the motor. The upper tray remains locked in position on the side fence (by the upper tray lift solenoid) while the lower tray is in use.

If sensor [B] fails, switch [C] stops the tray.

While the upper tray is being raised, motor [D] lifts the lower tray to the feed-out slot. The motor stops when the upper tray paper height sensor detects the tray.

Lower Tray Height Adjustment During Feed-out

Two sensors and a long feeler that contacts the top of the stack control the lower tray height during feed-out.

When the top of the stack is low, the feeler drops and the actuator swings up and actuates height sensor 1 [E]. As the stack grows higher, the feeler is pushed up until it actuates height sensor 2 [F]. After height sensor 2 remains active for 3 seconds, the lift motor [D] switches on and lowers the tray a short distance. This process repeats until the tray is full.

Lower Tray Full

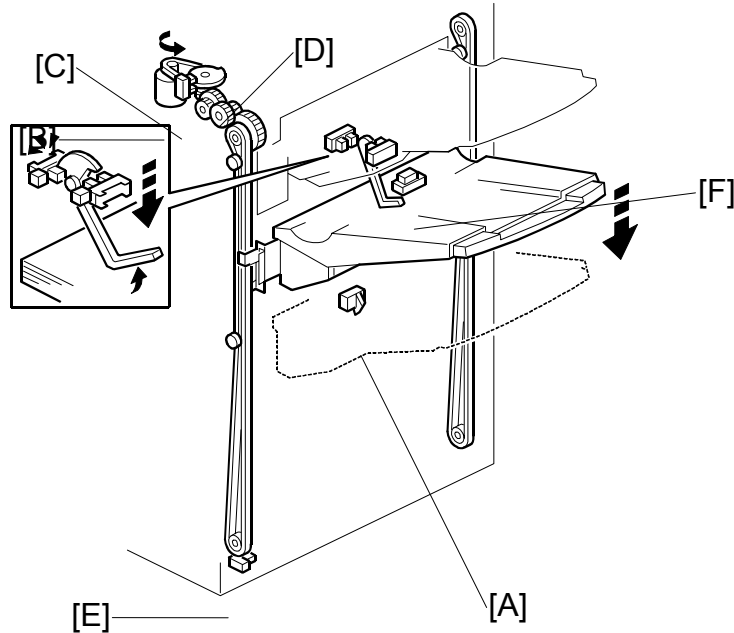

- [A]: Lower tray full sensor (sort/shift mode)
- [B]: Lower tray lift motor
- [C]: Lower tray encoder sensor
- [D]: Encoder disk
- [E]: Lower tray full sensor (saddle-stitch mode)
- [F]: Lower tray paper sensor

The sensor that is used depends on which mode the user has selected.

Normal sorting/stapling, without saddle stitching: When the bottom of the tray actuates sensor [A], the lift motor [B] continues to rotate for a certain number of rotations. The rotations are detected using sensor [C] and encoder disk [D]. Then printing stops. If sensor [C] fails, the upper limit switch (lower tray) stops the motor. This switch (not shown in the diagram) is next to the plastic foam roller at the feed-out slot.

Saddle-stitch mode: Sensor [A] is not used. The tray is lowered until the actuator on the side of the tray actuates sensor [E]. Then printing stops.

In both modes, when the stack is removed from the tray, sensor [F] de-actuates and returns the lower tray to the initial position at the feed-out slot.

6.5.6 SHIFT MECHANISM

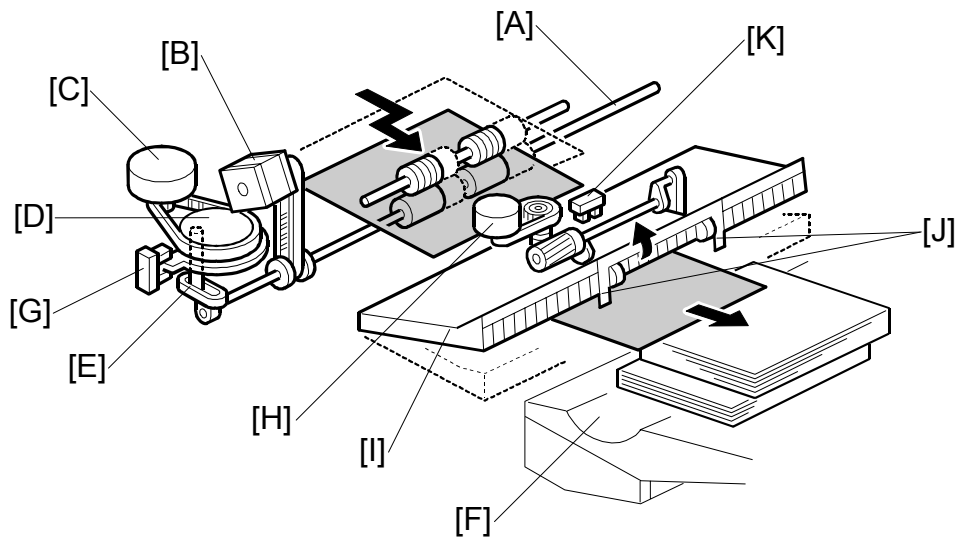

The same shift mechanism is used for the upper tray and lower tray.

Shift Roller Rotation

The shift roller [A] is turned by the shift roller motor [B].

Shift Roller Horizontal Movement

The shift roller is moved from left to right by the shift motor [C] and shift gear disk [D].

When the trailing edge of the copy passes the upper transport roller, the shift motor switches on, moving the shift roller to the left or right via the shift gear disk [D] and the link [E].

After the paper is delivered to the tray [F], the shift roller moves to the home position, detected by the shift HP sensor [G].

The process is repeated for every page of the same set, when the trailing edge of the page passes the transport roller.

For the next set, the shift motor rotates the gear disk in the opposite direction to shift every page of the next stack to the opposite side.

Exit Guide Plate

The guide plate motor [H] (a stepper motor) controls the opening and closing of the guide plate [I], via a cam and pin mechanism. The guide plate opens for each sheet to allow the shift, then closes to keep the sheet in the correct position for feed out. Two mylars [J] above the feed-out slot keep the copies straight in the feed path.

The guide plate position sensor [K] detects whether the guide plate is open or closed.

6.5.7 PAPER POSITIONING

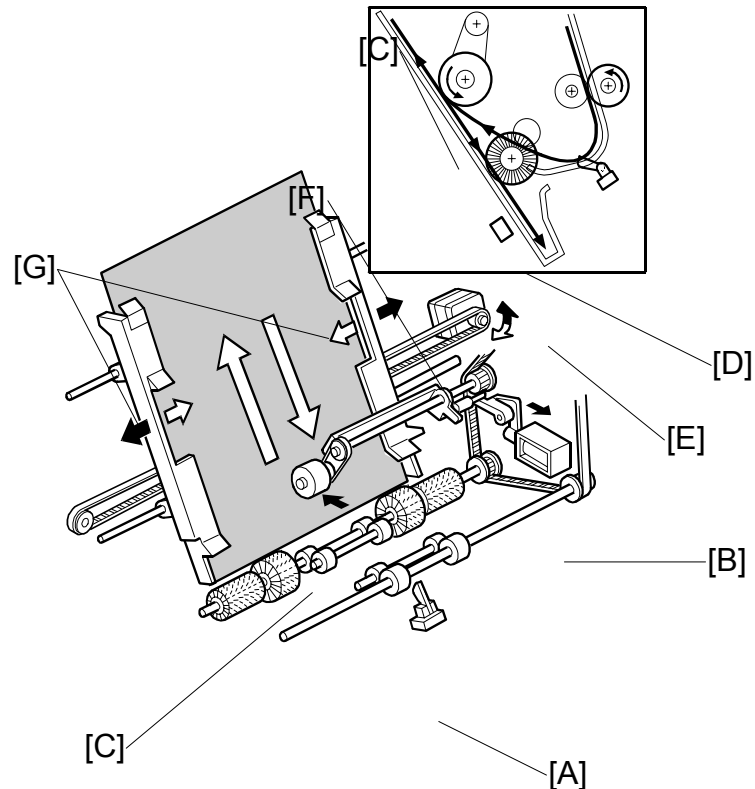

Vertical Alignment

When the trailing edge of the copy passes the stapler tray entrance sensor [A], the positioning roller solenoid [B] switches on long enough for the selected paper size and pushes the positioning roller [C] onto the paper. The positioning roller and alignment brush roller [D] rotate to push the paper and align the trailing edge of the paper with the stack stopper [E].

The stapler transport motor (not shown in this diagram) drives rollers [C] and [D].

Horizontal alignment

When the Start key is pressed, the jogger motor [F] switches on and opens the jogger fences 10 mm wider than the selected paper size.

When the leading edge of the sheet passes the staple unit entrance sensor, for the initial alignment, the jogger motor switches on for the prescribed time and closes the jogger fences 4 mm (2 mm closer to either side of the paper)

Next, the jogger motor switches on again for the prescribed time for the horizontal alignment to close the jogger fences 6 mm (3 mm to the sides of the paper) for the final alignment correction. The jogger motor switches on again and the fences return to the wait position 10 mm wider than the selected paper size.

6.5.8 STAPLER

Stapling Mechanism

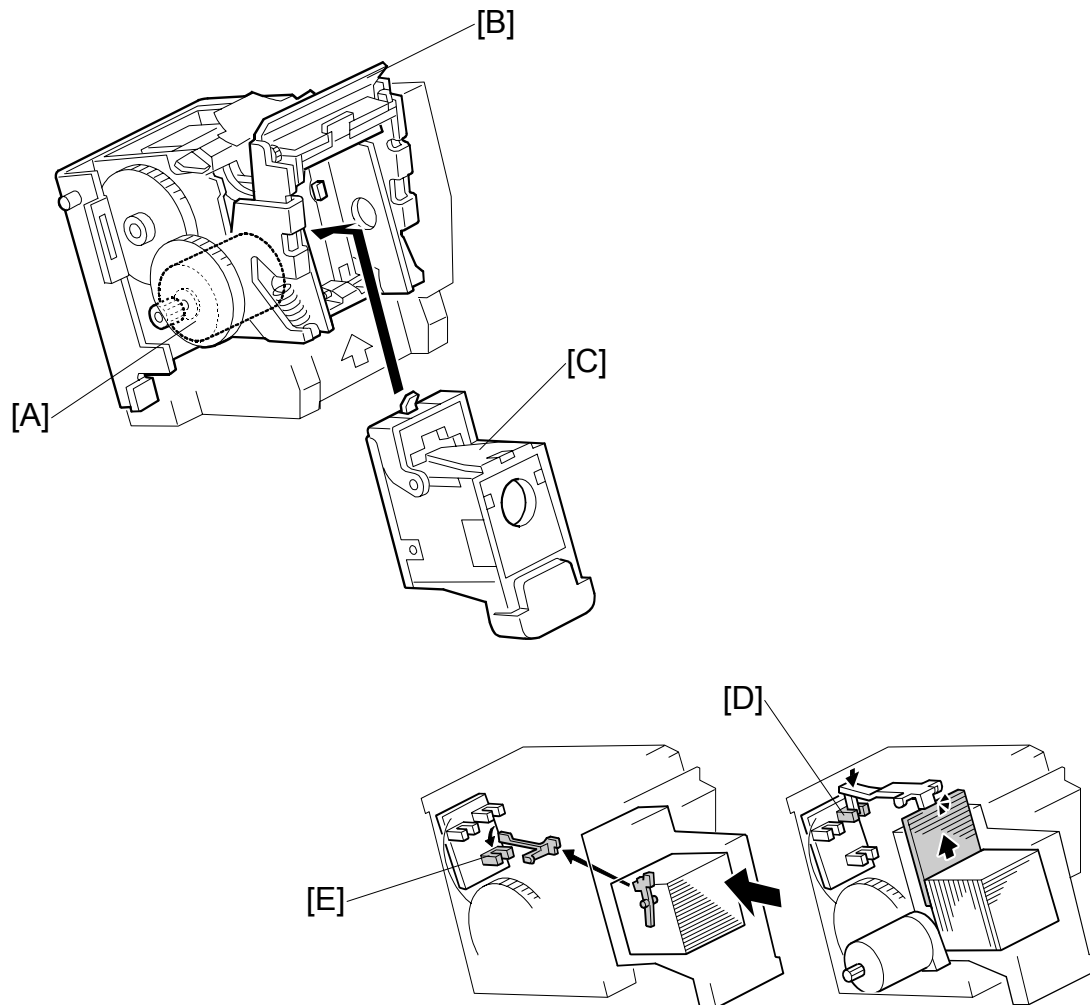

Staple firing is driven by the stapler motor [A] inside the stapler unit. The stapler hammer [B] fires the stapler [C].

The cartridge set sensor [D] detects the cartridge at the correct position, or logs an SC if the stapler unit is not at the correct position.

The stapler end sensor [E] detects the staple end condition and logs an SC.

6.5.9 STAPLER MOVEMENT

The stapler performs horizontal and rotational movement in each of the four staple modes.

Horizontal Stapler Movement

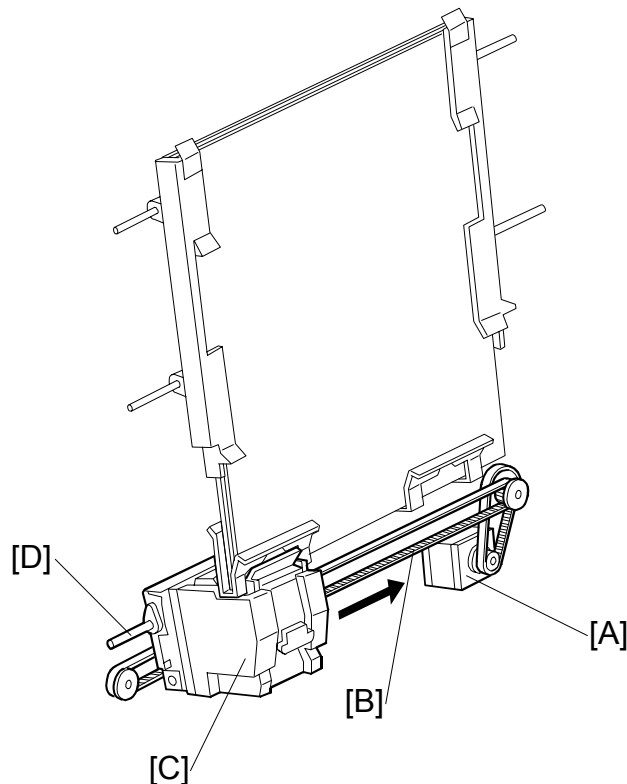

The stapler movement motor [A] drives the timing belt [B] which moves stapler [C] left and right on a support bar [D].

When the Start key is pressed, the jogger fences move to the wait position 10 mm wider than the selected paper size, the stapler motor switches on and moves the stapler to the staple position and then switches off. The motor switches on and off for the time needed to position the stapler for the paper size selected for the job.

If the stack is to be stapled at two locations, the stapler moves to the front position first, staples, moves to the back position, staples, and then returns to the home position.

NOTE: SP6120 001~011 (Staple Jogger Adjustment). Use this SP to fine adjust the staple unit jogger fences for different paper sizes. For details, see section "5. Service Tables".

Rotational Stapler Movement

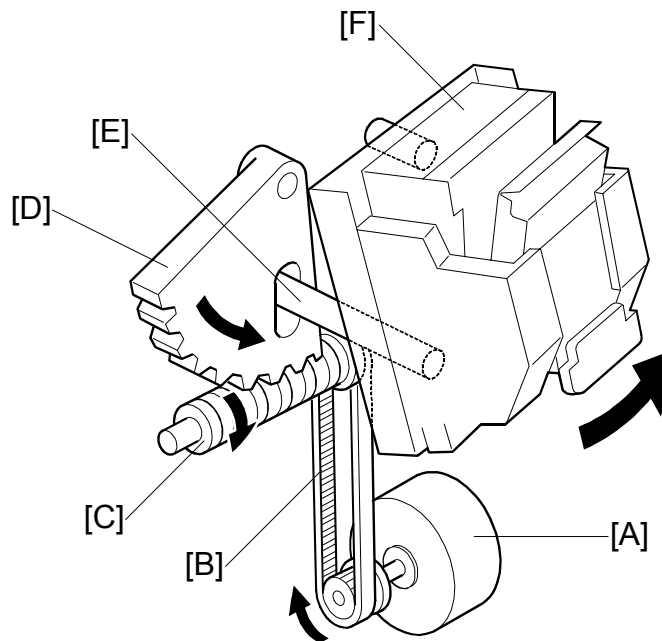

When the user has selected oblique stapling at one position, first the stapler motor switches on and off for the amount of time needed to move the stapler to the stapling position for the selected paper size.

At the correct time, the stapler rotation motor [A] switches on and via the timing belt [B] rotates the worm gear [C]. The worm gear drives the gear [D] and the lift arm [E], which lifts and positions the stapler unit [F] so the stapler can fire the staple at a 45 degree angle.

6.5.10 FEED OUT

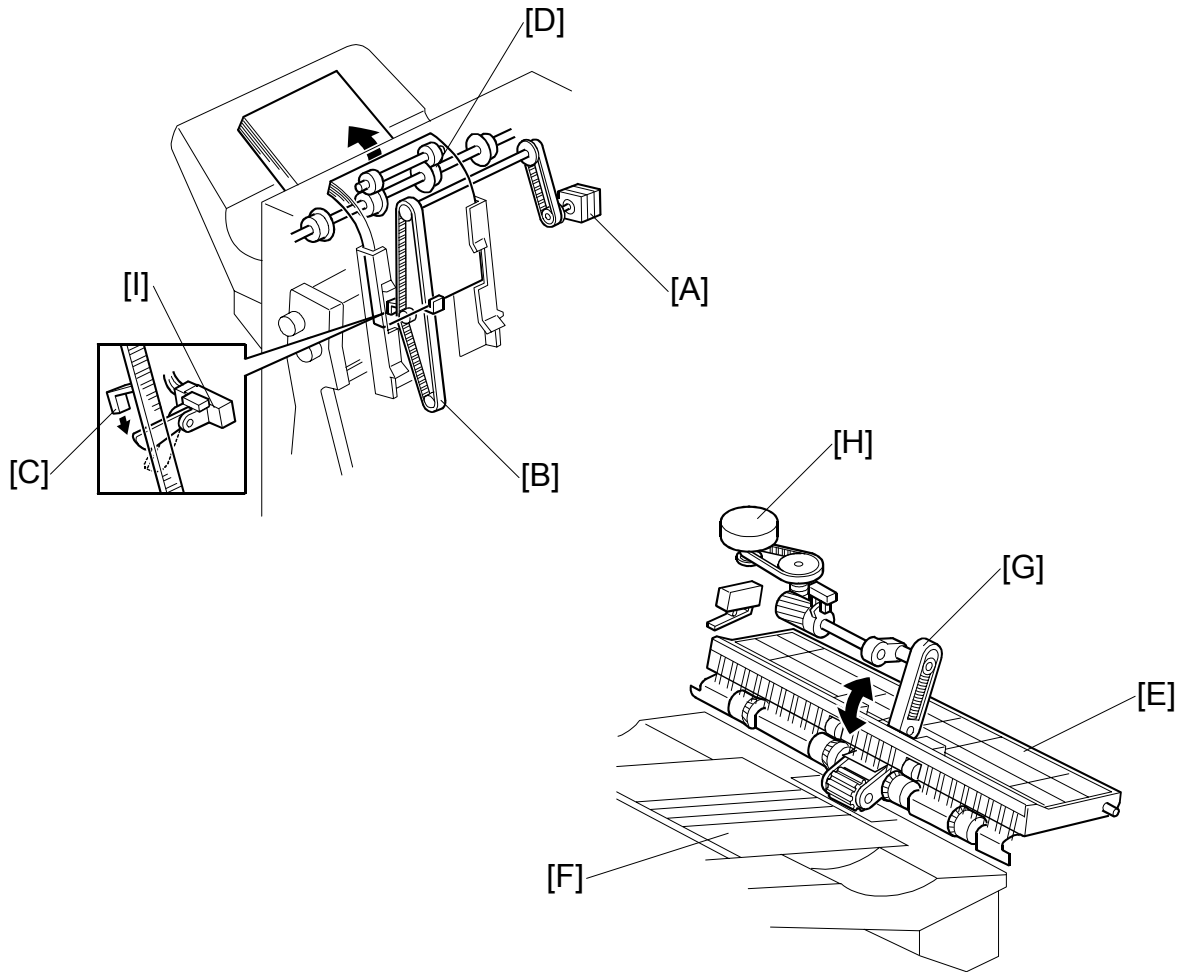

After a set has been stapled, the stack feed out motor [A] switches on and drives the stack feed out belt [B]. The pawl [C] on the belt lifts the stapled stack and transports it to the exit rollers [D]. There are two pawls on the belt, to increase productivity.

The exit guide plate [E] remains open until the leading edge of the stapled sheets has passed the prescribed distance from the tray exit rollers, then the exit guide plate closes, and the stapled sheets feed out to the tray [F].

A cam and pin [G], powered by the guide plate motor [H], opens and closes the guide plate.

The stack feed out motor stops for 300 ms to allow the exit rollers to feed out the stapled sheets to the output tray. This pause prevents the copies from pushing out too far onto the tray.

The stack feed out motor switches on again until the pawl actuates the stack feed out belt HP sensor [I].

6.5.11 BOOKLET FINISHING

OVERVIEW

Stapling: Two booklet staplers are used. These are about half way up the stack feed-out path. The stack feed-out belt moves the stack to the correct position for stapling.

Folding: This is done in two phases: initial folding and final folding.

- Initial folding: At the top of the stack feed-out belt, a plate pushes the centre of the copy (at the stapled place) through a pair of rollers to give the booklet an initial fold. However, this fold is only a partial fold.
- Final folding: The partially folded copy drops to the lower tray, where it is caught by a pressure plate mechanism, which completes the fold in the booklet before letting it drop onto the lower tray.

6.5.12 BOOKLET STAPLING AND FOLDING

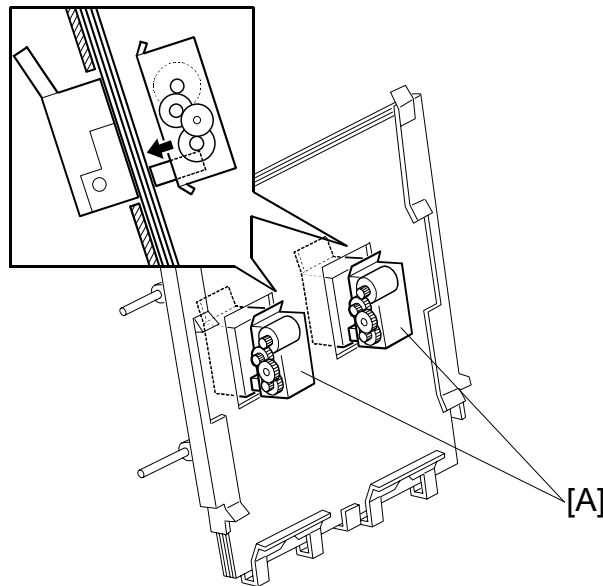

The sheets are aligned by the jogger fences before stapling. (☞ 3.5)

The aligned sheets are sent to the booklet stapler unit and positioned below the booklet staplers [A] for stapling at two locations in the center of the paper.

The stack feed-out belt lifts the booklet until two pawls on the folder plate mechanism (see the next page) catch the staples to position the booklet for folding.

6.5.13 INITIAL FOLDING

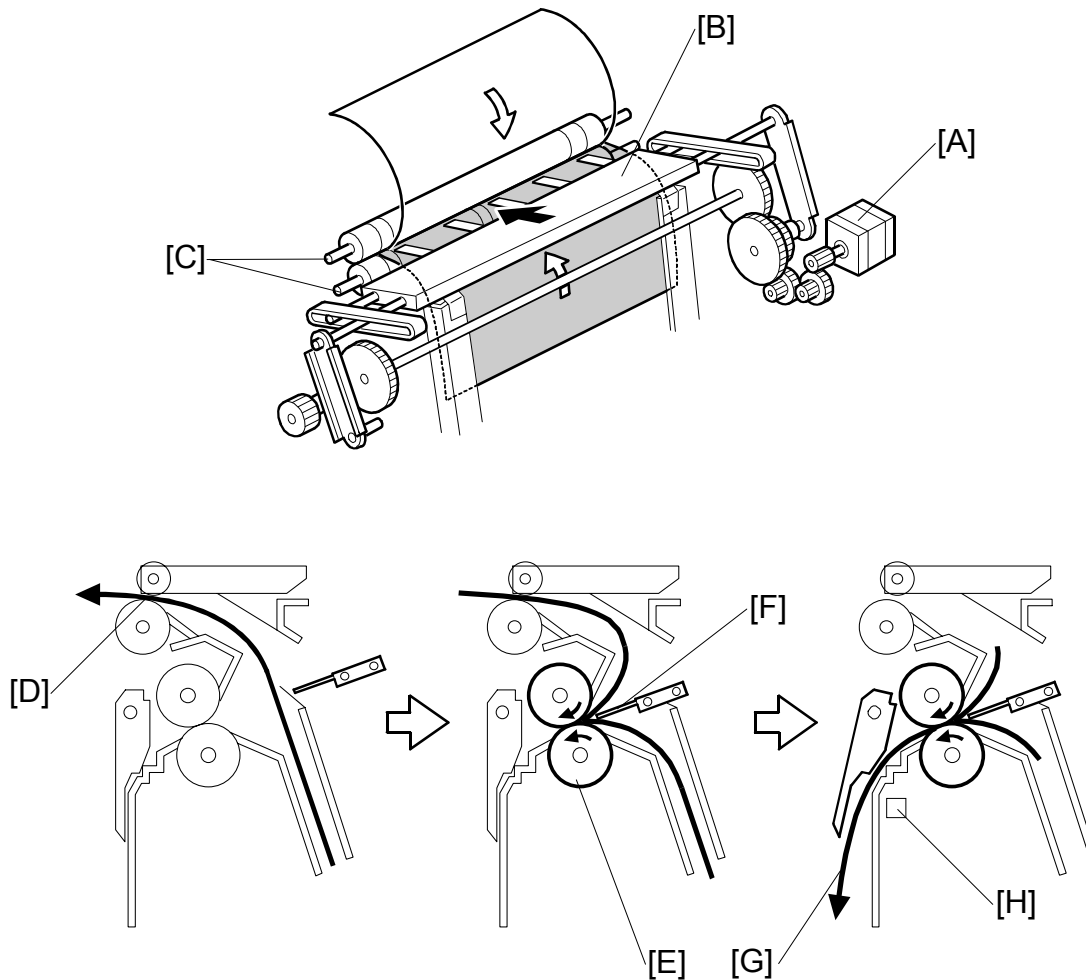

The folder plate motor [A] switches on and drives the folder plate [B] forward to push the center of the booklet into the nip of the folder rollers [C], giving the booklet a partial fold.

This is a detailed cross-section of the operation described above. The timing of the sequence depends on the size of the paper selected for the job.

The stack feed-out belt transports the booklet toward the paper exit [D] and stops when the center of the booklet is opposite the nip of the folder rollers [E].

The folder roller motor starts to turn and the folder rollers [E] start rotating. Then the folder plate motor switches on and pushes the folder plate [F] into the center of the booklet, driving the booklet between the rotating rollers. The booklet [G] (partially folded) then feeds out between the folder rollers.

The booklet exit sensor [H] detects the booklet when it leaves the folder rollers. This sensor triggers the mechanism for the next phase of the operation.

6.5.14 FINAL FOLDING AND FEED-OUT

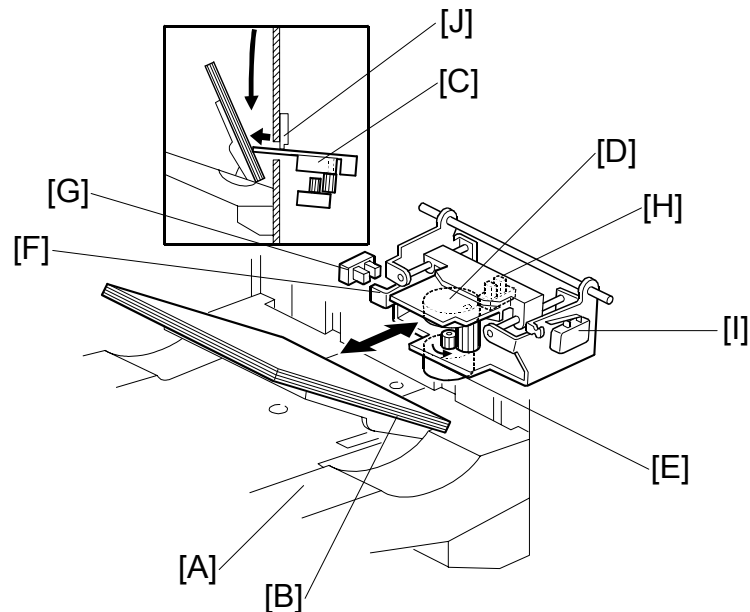

When the finisher is ready to feed out the first stapled booklet, the lower tray [A] descends past the pressure plate slot [J], the spring-loaded arms inside the lower tray snap into the grooves on the side fence, and the springs push the arms against the bottom of the support wing [B] to raise it.

Then, before the first stapled booklet falls from the slot above, the pressure plate motor [E] (stepper motor) rotates the gear and cam [D] counter-clockwise to extend the pressure plate [C]. The lower tray then raises and pushes the pressure plate up until the actuator [F] actuates the pressure plate lift sensor [G] and switches off the lower tray lift motor.

Then, the folded and stapled booklet comes out of the booklet exit slot, actuates the booklet exit sensor, and falls onto the pressure plate below. The actuated booklet exit sensor switches on the pressure plate motor, which rotates the gear and cam clockwise to retract the pressure plate. The motor rotates until the actuator on the rim of the cam actuates the pressure plate HP sensor [H] and stops the motor. Retracting the pressure plate allows the stapled booklet to fall past the pressure plate slot onto the stack below.

Next, the pressure plate motor switches on again to extend the pressure plate, while the lower tray raises and pushes the folded and stapled edges of the booklets up against the pressure plate until the actuator [F] actuates the pressure plate lift sensor [G] and switches off the lower tray lift motor. The booklets remain pressed between the extended pressure plate and lower tray until the next booklet is fed out.

The pressure plate limit switch [I] switches off the lower tray lift motor if the pressure plate lift sensor fails.

6.6 PUNCH UNIT B377 (OPTION)

The punch unit punches holes in printed sheets, one by one. The punch unit is provided with a new punch mechanism to improve the accuracy of punching.

NOTE: The illustrations below show the unit for Europe for 2/4 hole punching. The North American unit has five holes for 2/3 hole punching.

6.6.1 PUNCH DRIVE MECHANISM

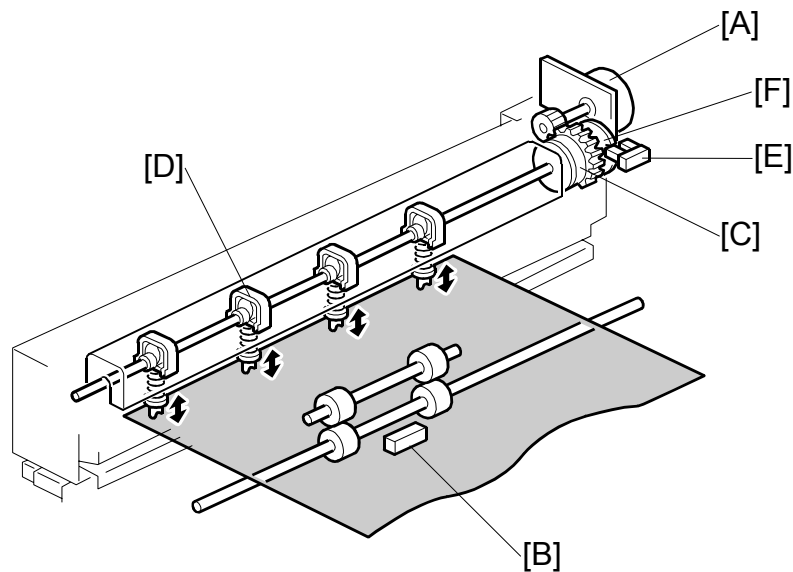

The punch motor [A] drives the punch mechanism. At the correct time after the trailing edge of the paper passes the finisher entrance sensor [B], the punch motor turns on and the paper stops. The punch clutch [C] turns and drives the punch heads [D].

The punch HP sensor [E] detects the home position for the actuator. The punch unit switches off when the cut-out in the punch shaft disk [F] enters the punch HP sensor.

NOTE: SP6113 (Punch Hole Adjustment) adjusts the punch hole position in the sub scan direction for two holes (001 2-Hole) or for three holes (002 3-Hole). Use the spacers provided with the punch unit to adjust the position of the punch in the main scan direction. For details, refer to the installation of the punch unit in section "1. Installation").

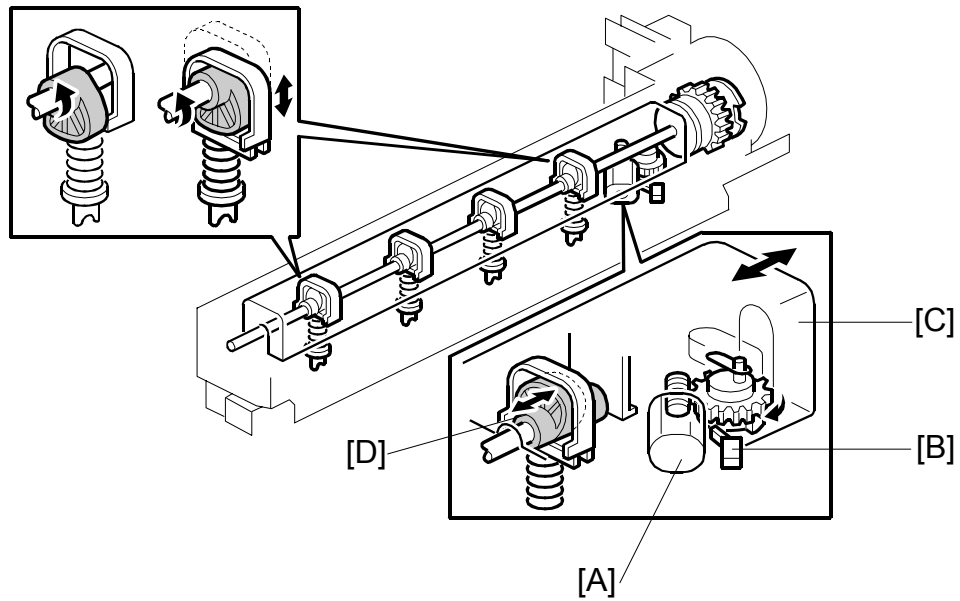

When the finisher has received the command that changes the number of punch holes for the job, the punch hole motor [A] turns on until the actuator disk changes the status of the punch hole switch [B] (until it switches on or off). This indicates that the cover [C] and the punch cam [D] have moved to one side or the other to determine which punchers are used.

6.6.2 PUNCH WASTE COLLECTION

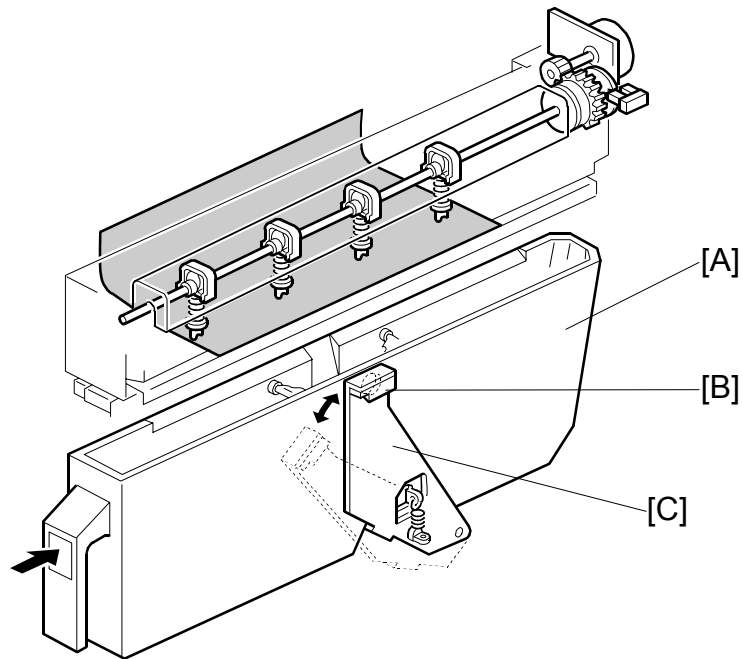

Waste punchouts are collected in the punch waste hopper [A] below the punch unit inside the finisher.

When the top of the punchout waste in the hopper reaches and actuates the hopper sensor [B], a message will be displayed on the operation panel after the current job is completed.

This sensor also detects whether the punch waste hopper is installed. When the waste hopper is taken out, the arm [C] moves down and this will actuate the sensor and display a message in the operation panel. This message is the same as for the hopper full condition.

SECTION 7
3,000-SHEET FINISHER
MJ-1026

7. SR840 3000 SHEET FINISHER (B478)

7.1 SPECIFICATION

UPPER TRAY			
Paper Capacity (80 g/m ²)	500 sheets (A4, 8 1/2" x 11" and smaller)		
	250 sheets (B4, 8 1/2" x 14" and larger)		
Paper Size	A3 to A6 SEF, 11" x 17" to 5 1/2" x 8 1/2", 12" x 18"		
Paper Weight	52 to 216 g/m ²		
Upper Tray Full Detection	Provided		
SHIFT TRAY			
Paper Capacity (80 g/m ²)	3000 sheets (A4 LEF, B5 LEF, 8 1/2" x 11" LEF)		
	1500 sheets (A3, A4 SEF, B4 and B5 SEF, 11" x 17", 8 1/2" x 14", 8 1/2" x 11" SEF, 12" x 18")		
	500 sheets (A5 LEF, 5 1/2" x 8 1/2" LEF)		
	100 sheets (A5 SEF, 5 1/2" x 8 1/2" SEF)		
Paper Size	A3 to A5, 11" x 17" to 5 1/2" x 8 1/2", 12" x 18" (including tab paper)		
Paper Weight	52 to 216 g/m ²		
Shift Tray Full Detection	Provided		
STAPLER			
Stapling Stack Size	A4, B5, 8 1/2" x 11" (Max. 100 Sheets) A3, B4, 11" x 17", 8 1/2" x 14" (Max. 50 sheets)		
Stapling Paper Size	A3 to B5 11" x 17" to 8 1/2" x 11"		
Stapling Paper Weight	64 to 80 g/m ²		
Staple Position	4 Modes		
	1 Staple: Front, Rear, Rear-Oblique		
	2 Stapes: 2 locations		
Staple Capacity	5000 staples/cartridge		
Staple Supply	Cartridge or Staple Replacement		
Stapled Stack Size	Sheets	Sets	Sizes
	10 ~ 100	200 ~ 30	A4 SEF, B5 SEF, 8 1/2" x 11" SEF
	2 ~ 9	150	A4 LEF, B5 LEF, 8 1/2" x 11" LEF
	10 ~ 50 2 ~ 9	150 ~ 30 150	A3, B4, 11" x 17", 8 1/2" x 14"
Trim Waste Staple Capacity	30,000 or more		
Waste Staple Hopper Full Detection	Provided		
Power Consumption	Less than 100 W		
Power Source	DC 24 V (From Mainframe)		
Size (W x D x H)	800 x 730 x 980 mm 31.5 x 28.7 x 38.6 in.		
Weight	Less than 65 kg (143 lb.)		
Compatible Machines	B070 (90 cpm), B071 (105 cpm), B064 (60 cpm), B065 (75 cpm)		

7.1.1 SPECIFICATION PUNCH UNIT (B531)

The Punch Unit B531 is installed in the 3000 Sheet Finisher .

Punch Hole Positions	2/3-hole (North America) 2/4-hole (Europe)
Punch Paper Size	
2-Hole (NA)	A5 ~ A3 SEF, 11" x 17"~5 1/2" x 8 1/2" SEF A5 ~ A4 LEF, 8 1/2" x 11" LEF, 5 1/2" x 8 1/2" LEF
3-Hole (NA)	A3 SEF, B4 SEF, 11" x 17" SEF A4 LEF, B5 LEF, 8 1/2" x 11" LEF
4-Hole (EUR/A)	A3 SEF, 11" x 17" SEF A4 LEF, 8 1/2" x 11" LEF
Paper Weight	
2-Hole (NA)	52 g/m ² ~ 163 g/m ²
3-Hole (NA)	52 g/m ² ~ 163 g/m ²
4-Hole (EUR/A)	52 g/m ² ~ 128 g/m ²
Punch Waste Hopper Capacity	
2-Hole (NA)	10K
3-Hole (NA)	15K
4-Hole (EUR/A)	15K
Operation Modes	All (Shift, Proof, Staple)

DIP SW Settings

The correct DIP SW settings of the Punch Unit 531 are provided in the table below for your reference only. The DIP switches of these punch units do not need to be changed at installation, or adjusted for operation.

Punch Unit	Unit No.	DIP SW Settings			
		1	2	3	4
2/3-Hole (NA)	B531-17	1	0	1	0
2/4-Hole (EUR/A)	B531-27	1	0	0	1

0: OFF

1: ON

7.1.2 SPECIFICATION PUNCH UNIT (A812)

The Punch Unit A812 is installed in the 3000 Sheet Finisher B478.

Punch Hole Positions	2-hole, 3-hole (NA) 4-hole (EUR/A) 4-hole (North Europe)
Punch Paper Size	
2-Hole	A5 ~ A3 SEF, 11" x 17" ~ 8 1/2" x 11" SEF A5 ~ A4 LEF, 8 1/2" x 11" LEF
3-Hole (NA)	A3 SEF, B4 SEF, 11" x 17" SEF A4 LEF, B5 LEF, 8 1/2" x 11" LEF
4-Hole (EUR/A)	A3 SEF, 11" x 17" SEF A4 LEF, 11" x 17" LEF
4-Hole (North Europe)	B5 ~ A3 SEF, 8 1/2" x 11" ~ 11" x 17" SEF A5 ~ A4 LEF, 8 1/2" x 11" LEF, 5 1/2" x 8 1/2" LEF
Paper Weight	
2-Hole, 3-Hole (NA)	52 g/m ² ~ 163 g/m ²
4-Hole (Europe/North Europe)	52 g/m ² ~ 128 g/m ²
Punch Waste Hopper Capacity	
2-Hole	40K
3-Hole (NA)	15K
4-Hole (EUR/A)	15K
4-Hole (North Europe)	15K
Power Supply	DC 24 V (From Finisher)
Power Consumption	60 W
Weight	Less than 2.4 K (5.3 lb.)
Operation Modes	All (Shift, Proof, Staple)

DIP SW Settings

The correct DIP SW settings of the Punch Unit A812 are provided in the table below for your reference only. The DIP switches of these punch units do not need to be changed at installation, or adjusted for operation.

Punch Unit	Unit No.	DIP SW Settings			
		1	2	3	4
2-Hole (EUR/A)	A812-40/A812-67	0	0	0	0
3-Hole (NA)	A812-57	1	0	0	0
4-Hole (EUR/A)	A812-30	0	1	0	0
4-Hole (North Europe)	A812-31	0	0	1	0
2-Hole (NA)	A812-32	0	0	0	1

0: OFF

1: ON

7.1.3 SPECIFICATION JOGGER UNIT B513

The Jogger Unit B513 is installed above the shift tray of the 3000 Sheet Finisher B478.

Paper Size	A3 SEF, B4 SEF, 11" x 17" SEF A4 LEF, B5 LEF, 8 1/2" x 11" LEF
Paper Weight	52 g/m ² ~ 216 g/m ²
Weight	Less than 1.7 kg (3.7 lb.)
Dimensions (W x D x H)	125 mm x 450 mm x 100 mm 5" x 17.7" x 4"
Power Supply	DC 24 V, DC 5V (From Finisher)
Power Consumption	24 W

7.2 MECHANICAL COMPONENT LAYOUT

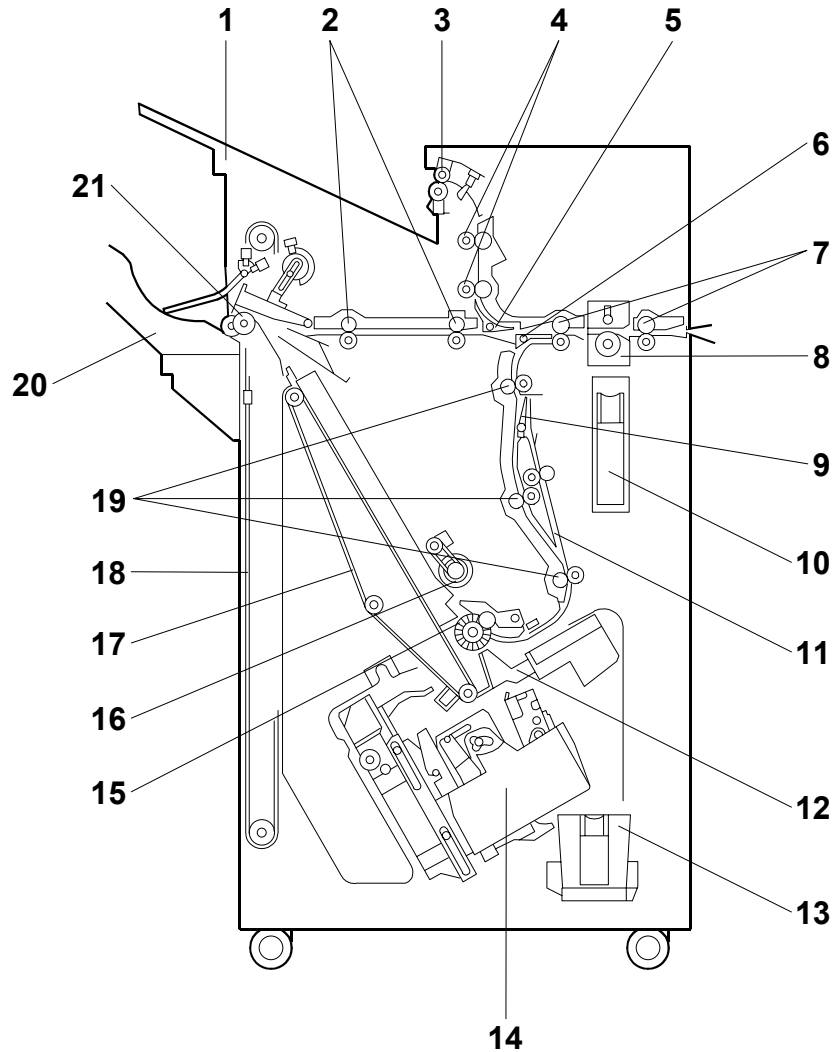

- | | |
|-----------------------------|-----------------------------|
| 1. Upper Tray | 12. Stack Plate |
| 2. Middle Transport Rollers | 13. Staple Waste Hopper |
| 3. Upper Tray Exit Roller | 14. Stapler |
| 4. Upper Transport Rollers | 15. Alignment Brush Roller |
| 5. Tray Junction Gate | 16. Positioning Roller |
| 6. Stapler Junction Gate | 17. Stack Feed-out Belt |
| 7. Entrance Rollers | 18. Shift Tray Drive Belt |
| 8. Punch Unit | 19. Lower Transport Rollers |
| 9. Pre-stack Junction Gate | 20. Shift Tray |
| 10. Punch Waste Hopper | 21. Shift Tray Exit Roller |
| 11. Pre-stack Tray | |

7.3 ELECTRICAL COMPONENT DESCRIPTION

Symbol	Name	Function
Motors		
M01	Shift Tray Exit	Drives the exit roller for the shift tray.
M02	Shift Tray Lift	Moves the shift tray up or down.
M03	Exit Guide	Opens and closes the upper exit guide.
M04	Lower Transport	Drives the lower transport rollers, the positioning roller and the alignment brush roller
M05	Shift	Moves the shift tray from side to side.
M06	Positioning Roller	Moves the positioning roller into contact with the paper.
M07	Stacking Roller Drag	Moves the stacking roller in and out.
M08	Stacking Roller	Rotates the stacking roller.
M09	Jogger	Moves the jogger fences.
M10	Stack Feed-Out Belt	Drives the stack feed-out belt.
M11	Stack Plate - Center	Presses down the center of the edge for stapling.
M12	Stapler	Moves the staple unit from side to side.
M13	Stack Plate – Front	Presses down the front corner of the edge for stapling.
M14	Stack Plate – Rear	Presses down the rear corner of the edge for stapling.
M15	Stapler Rotation	Rotates the stapler 45 degrees for oblique stapling.
M16	Staple Hammer	Drives the staple hammer.
M17	Punch	Drives the punch shaft and roller. Punch Unit B531 (option).
M18	Upper Transport	Drives the entrance rollers, the middle and upper transport rollers, and upper tray exit roller.
M19	Shift Jogger	Drives the shift jogger fences against the sides of the sheets to align the stack, then reverses to return them to the home position. Jogger Unit B513 (option).
M20	Shift Jogger Lift	Raises the shift jogger fences after aligning the stack, then reverses and lowers them when returning to the home position. Jogger Unit B513 (option).
BOARDS		
PCB	Main	Controls the finisher and communicates with the copier.
PCB	Stapler	Controls the stapler unit.
PCB	Punch	Passes signals between the punch unit and the finisher main board. Punch Unit B531 (option).
PCB	Jogger	Controls the shift/jogger unit B513 (option).
SENSORS		
S01	Entrance	Detects the copy paper entering the finisher and checks for misfeeds.
S02	Upper Tray Exit	Checks for misfeeds at the upper tray.
S03	Upper Tray Limit	Detects when the paper stack height in the upper tray is at its upper limit.
S04	Shift Tray Exit	Checks for misfeeds at the shift tray exit.
S05	Exit Guide Open	Detects whether the guide plate is opened or not.
S06	Staple Mode HP 1	Detects the shift tray home position for standby mode and for staple mode.

Symbol	Name	Function
S07	Staple Mode HP 2	Detects the shift tray home position for standby mode and for staple mode.
S09	Shift Lower Limit – Large Paper	Detects the lower limit for the shift tray when large paper sizes are being used
S10	Shift Tray Lower Limit 2	Not used.
S11	Shift Tray Lower Limit 3	Detects when the shift tray is at its lower limit.
S12	Shift Mode HP	Detects the shift tray home position in sort/stack mode.
S13	Stacking Roller HP	Detects when the stacking roller is at home position.
S14	Shift Tray Half-Turn	Detects whether the shift tray is at either the front or home HP.
S15	Pre-Stack Tray Paper	Determines when to turn off the pre-stack paper stopper solenoid.
S16	Stapler Tray Exit	Detects jams at the staple tray exit.
S17	Positioning Roller HP	Detects the home position of the positioning roller.
S18	Stack Feed-Out Belt HP	Detects the home position of the stack feed-out belt.
S19	Stapler Tray Paper	Detects the copy paper in the stapler tray.
S20	Jogger HP	Detects the home position of the shift jogger fences.
S21	Stack Plate - Center HP	Detects the home position of the center stack plate.
S22	Stack Plate – Front	Detects the home position of the front stack plate.
S23	Stack Plate – Rear	Detects the home position of the rear stack plate.
S24	Stapler HP	Detects the home position of the staple unit for side-to-side movement.
S25	Stapler Rotation HP	Detects the home position of the stapler unit for 45-degree rotation.
S26	Stapler Return	Detects the on timing of the stapler return solenoid.
S27	Staple Waste Hopper	Detects when the staple waste hopper is full.
S28	Punch Waste Hopper	Detects when the punch waste hopper is full and detects when the punch tray is set. Punch Unit B531 (option).
S29	Punch HP 1	Detects the cam home position for the 2-hole punch. Punch Unit B531 (option).
S30	Punch HP 2	Detects the cam home position for 3/4 punch. Punch Unit B531 (option).
S31	Shift Jogger HP	Detects the home position of the jogger unit arms during paper alignment. Jogger Unit B513 (option).
S32	Shift Jogger Lift HP	Detects the when both shift jogger fences are at the lowered position and ready to move against the sides of the stack. Jogger Unit B513 (option).

Symbol	Name	Function
SOLENOIDS		
SOL1	(Upper) Tray Junction Gate	Drives the tray junction gate.
SOL2	Stapler Junction Gate	Drives the stapler junction gate.
SOL3	Pre-Stack Junction Gate	Drives the pre-stack junction gate.
SOL4	Pre-stack Paper Stopper	Drives the stopper pawl of the pre-stacking tray.
SOL5	Stapler Return	Positions the stapler correctly on its return from the staple supply point.
SWITCHES		
SW1	Shift Tray Upper Limit	Cuts the power to the shift tray lift motor when the shift tray position is at its upper limit.
SW2	Front Door Safety	Cuts the dc power when the front door is opened.
SW3	Emergency Stop	Switches the current job off and on to allow time for the operator to remove paper from the shift tray.

7.4 DRIVE LAYOUT

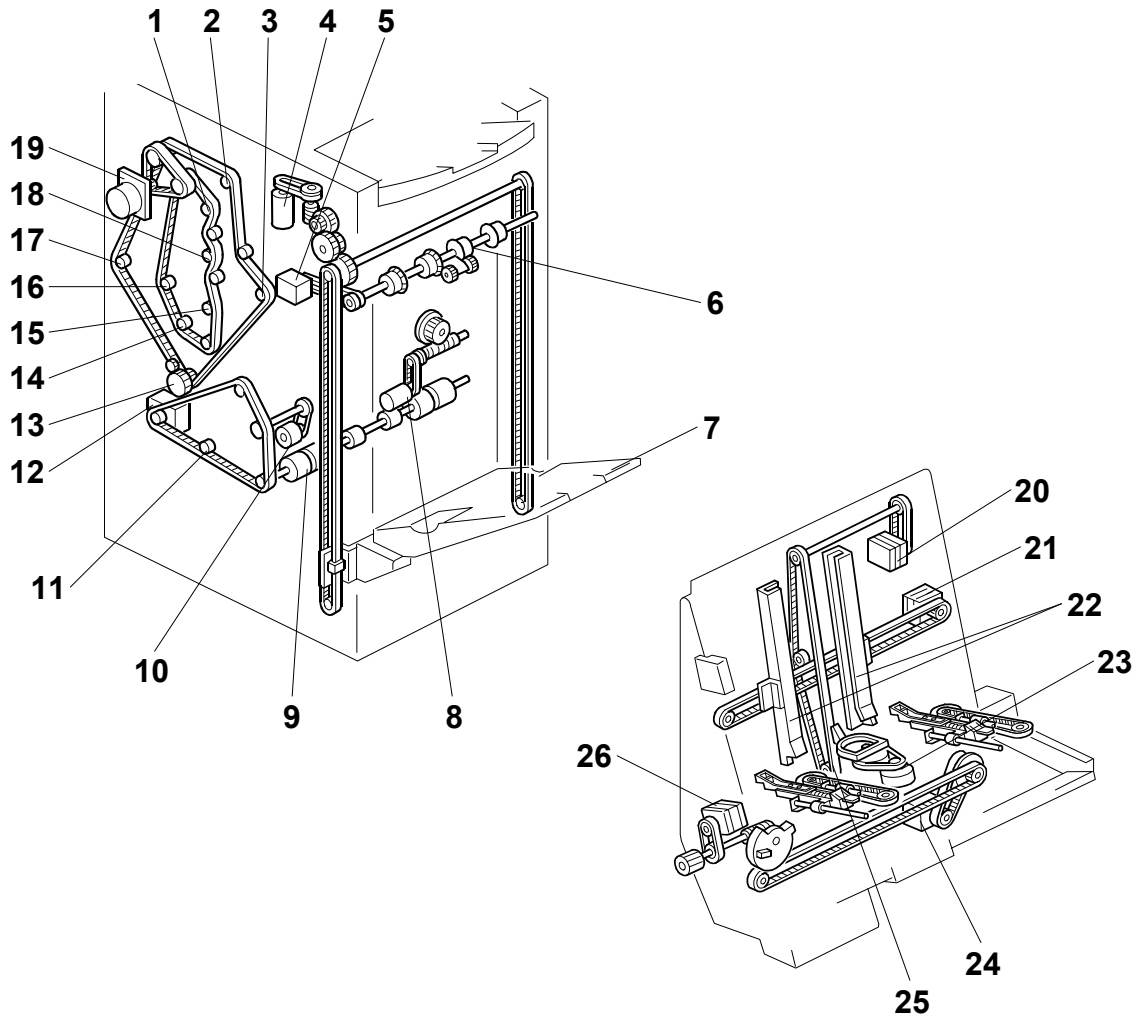

- | | |
|-------------------------------|------------------------------|
| 1. Upper Transport Roller 2 | 14. Lower Transport Roller 1 |
| 2. Upper Tray Exit Roller | 15. Transport Roller 1 |
| 3. Lower Transport Roller 2 | 16. Entrance Roller 2 |
| 4. Shift Tray Lift Motor | 17. Entrance Roller |
| 5. Shift Tray Exit Motor | 18. Upper Transport Roller 1 |
| 6. Shift Tray Exit Roller | 19. Upper Transport Motor |
| 7. Shift Tray | 20. Stack Feed-out Motor |
| 8. Shift Motor | 21. Jogger Motor |
| 9. Staple Tray Exit Roller | 22. Jogger Fence |
| 10. Positioning Roller | 23. Stack Plate Motor |
| 11. Lower Transport Roller 3 | 24. Stapler Motor |
| 12. Lower Transport Motor | 25. Stack Feed-out Belt |
| 13. Lower Transport Rollers 2 | 26. Stapler Rotation Motor |

7.5 DETAILED DESCRIPTIONS

7.5.1 TRAY AND STAPLER JUNCTION GATE

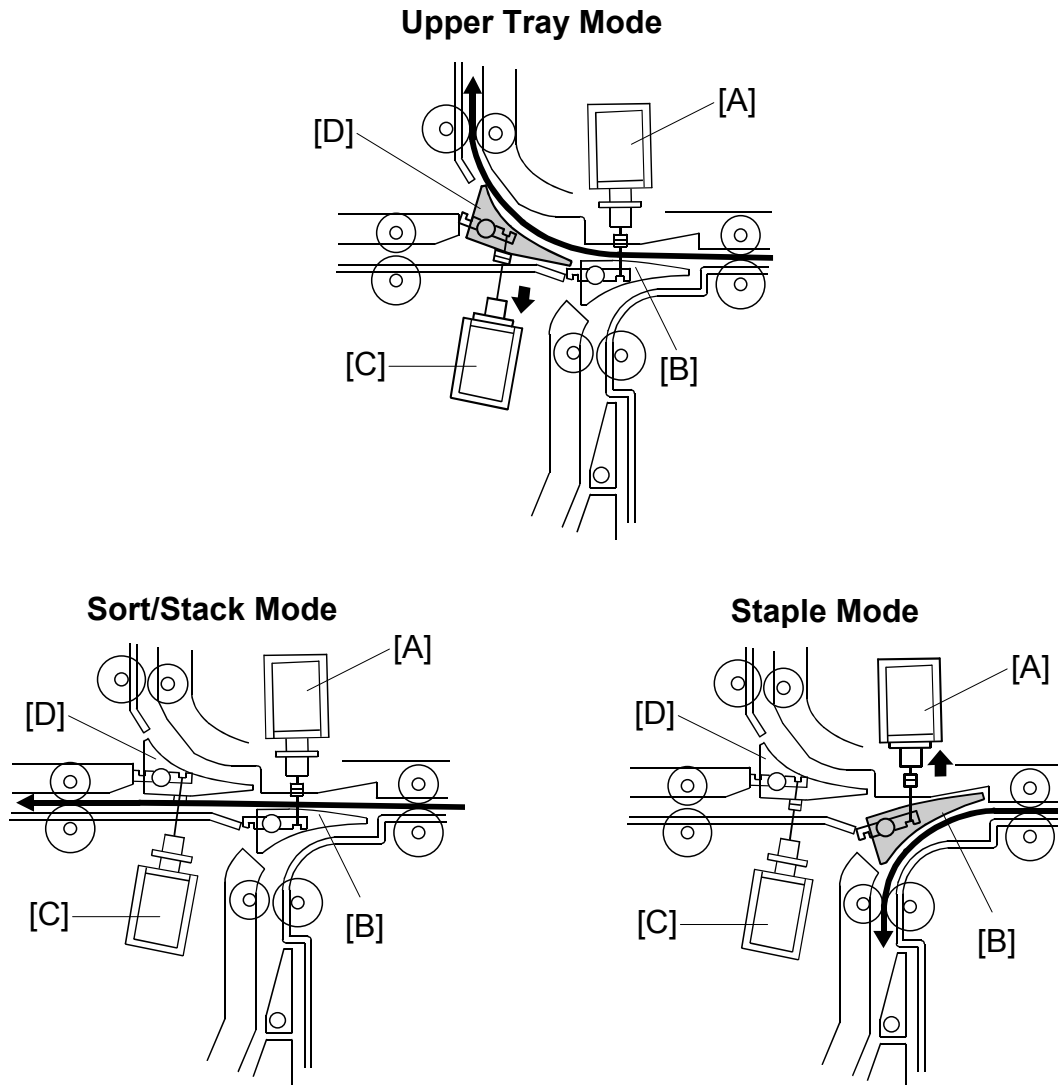

Depending on the finishing mode, the copies are directed up, straight through, or down by the combinations of open and closed junction gates.

Solenoid/Gate		Selected Operation Mode		
		Upper Tray	Sort/Stack	Staple
[A]	Stapler junction gate solenoid	Off	Off	ON
[B]	Stapler junction gate	Closed	Closed	OPEN
[C]	Tray junction gate solenoid	ON	Off	Off
[D]	Tray junction gate	OPEN	Closed	Closed

7.5.2 PAPER PRE-STACKING

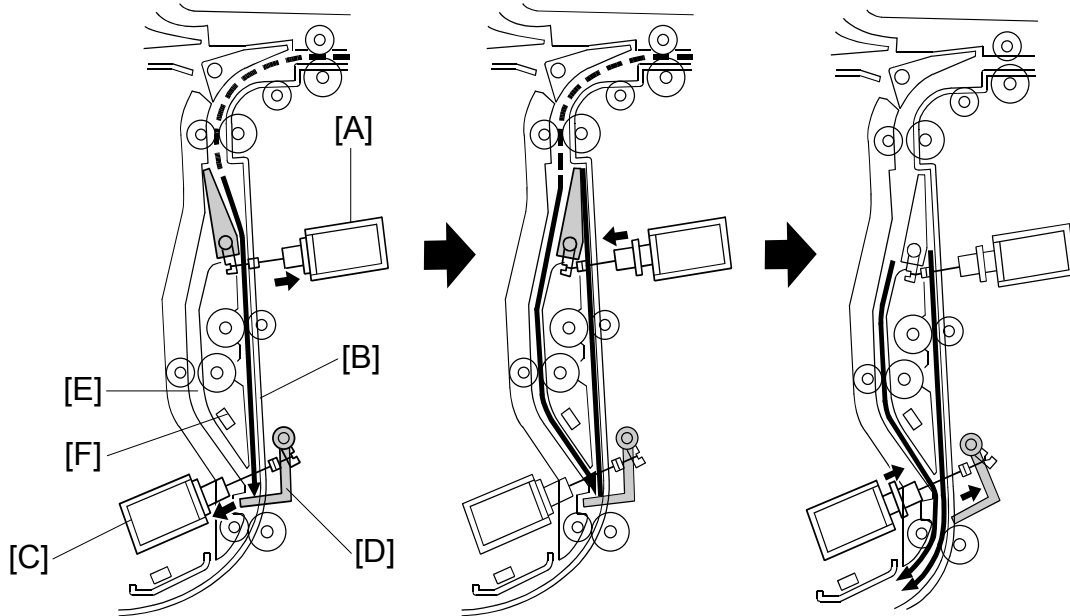

This mechanism improves productivity in staple mode. It is only used when copying on A4, LT, or B5 (all LEF).

During stapling, the copier has to wait. This mechanism reduces the wait by holding the first two sheets of a job while the previous job is still being stapled. It only works during the second and subsequent sets of a multi-set copy job.

The pre-stack junction gate solenoid [A] turns on 120 mm after the 1st sheet of paper turns on the entrance sensor, and this directs the sheet to the pre-stack tray [B]. (This sheet cannot be fed to the stapler yet, because the first set is still being stapled.) The pre-stack paper stopper solenoid [C] turns on 350 mm after the 1st sheet turns on the entrance sensor. The pre-stack paper stopper [D] then stops the paper.

The pre-stack junction gate solenoid turns off 230 mm after the trailing edge of the 1st sheet passes through the entrance sensor, and the 2nd sheet is sent to the paper guide [E]. The pre-stack paper stopper is released about 40 mm after the 2nd sheet turns on the pre-stack stopper sensor [F], and the two sheets of copy paper are sent to the stapler tray. All sheets after the 2nd sheet go to the stapler tray via the paper guide [E].

7.5.3 JOGGER UNIT PAPER POSITIONING

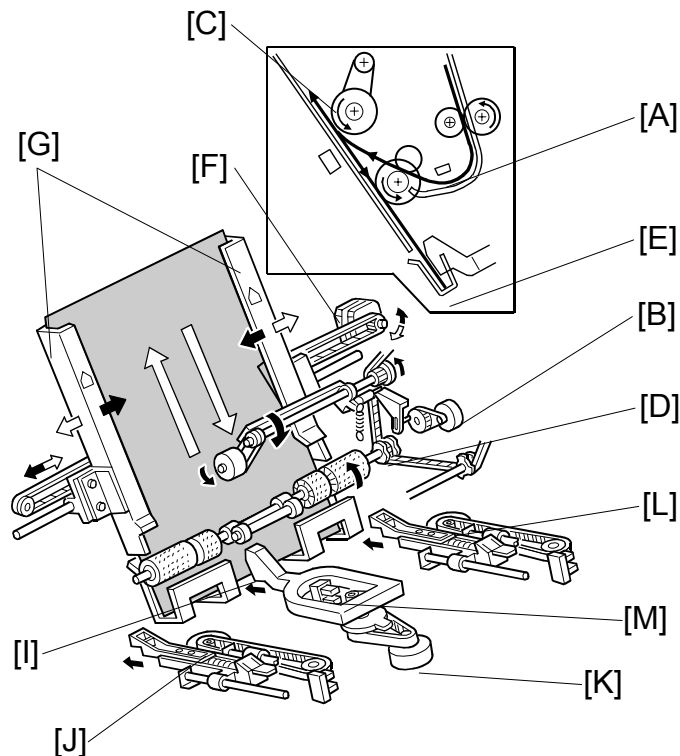

In the staple mode, as every sheet of paper arrives in the jogger unit, it is vertically and horizontally aligned, then the staple edge is pressed flat to ensure the edge of the stack is aligned correctly for stapling.

Vertical Paper Alignment: About 60 ms after the trailing edge of the copy passes the staple tray entrance sensor [A], the positioning roller motor [B] is energized to push the positioning roller [C] into contact with the paper. The positioning roller and alignment brush roller [D] rotate to push the paper back and align the trailing edge of the paper against the stack stopper [E].

Horizontal Paper Alignment: When the print key is pressed, the jogger motor [F] turns on and the jogger fences [G] move to the wait position about 7.2 mm wider than the selected paper size on both sides. When the trailing edge of the paper passes the staple unit entrance sensor, the jogger motor moves the jogger fences 3.7 mm towards the paper. Next, the jogger motor turns on again for 3.5 mm for the horizontal paper alignment then goes back to the wait position.

Paper Stack Correction: After the paper is aligned in the stapler tray, the left [J], center [K], and right [L] stack plate motors switch on briefly and drive the front stack, center stack, and rear stack plates against the edge of the stack to flatten the edge completely against the staple tray for stapling. When the next copy paper turns on the stapler entrance sensor, the stack plate motor turns on and returns to its home position. The home position is detected by stack plate HP sensor [M].

7.5.4 STAPLER UNIT MOVEMENT

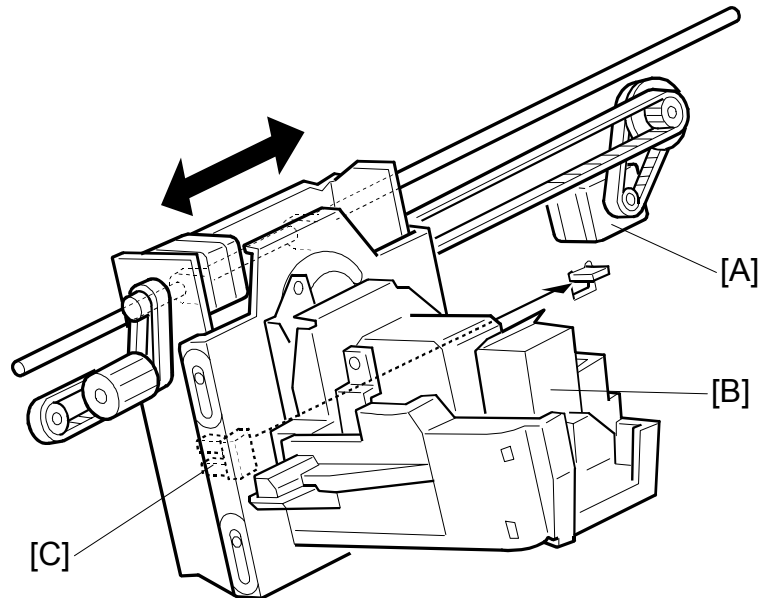

Side-to-Side

The stapler motor [A] moves the stapler [B] from side to side. After the start key is pressed, the stapler moves from its home position to the stapling position.

If two-staple-position mode is selected, for the first stack the stapler moves to the rear stapling position first, staples, moves to the front position, staples and waits at the front. For the second stack, the stapler staples the front corner first, then moves to the rear corner and staples.

NOTE: For continuous stapling jobs, the corners are stapled rear then front for the odd number stacks and stapled front then rear for even number stacks.

After the job is completed, the stapler returns to its home position. This is detected by the stapler HP sensor [C].

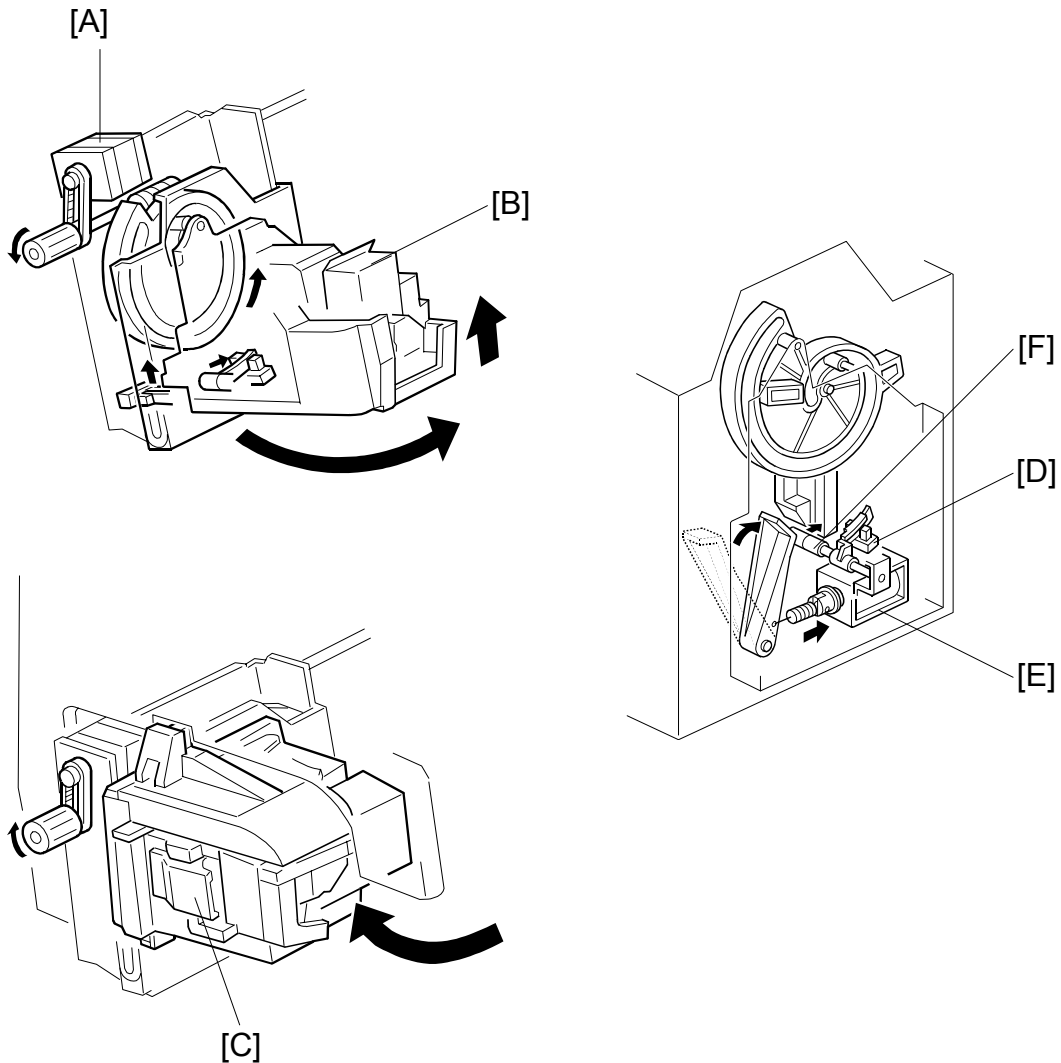

Rotation (1)

In the oblique staple position mode, the stapler rotation motor [A] rotates the stapler units [B] 45° to counterclockwise after it moves to the stapling position.

Rotation (2)

When the staple end condition arises, the stapler motor moves the stapler to the front and the stapler rotation motor rotates the stapler unit to clockwise to remove the staple cartridge [C]. This allows the user to add new staples.

Once the staples have been installed, and the front door closed, the stapler unit returns to its home position. As the stapler unit is returning to the home position, the stapler return sensor [D] is activated, the return solenoid [E] turns on and it assists the guide roller [F] to return to its guide (this guide directs the stapler during rotation).

7.5.5 STAPLER

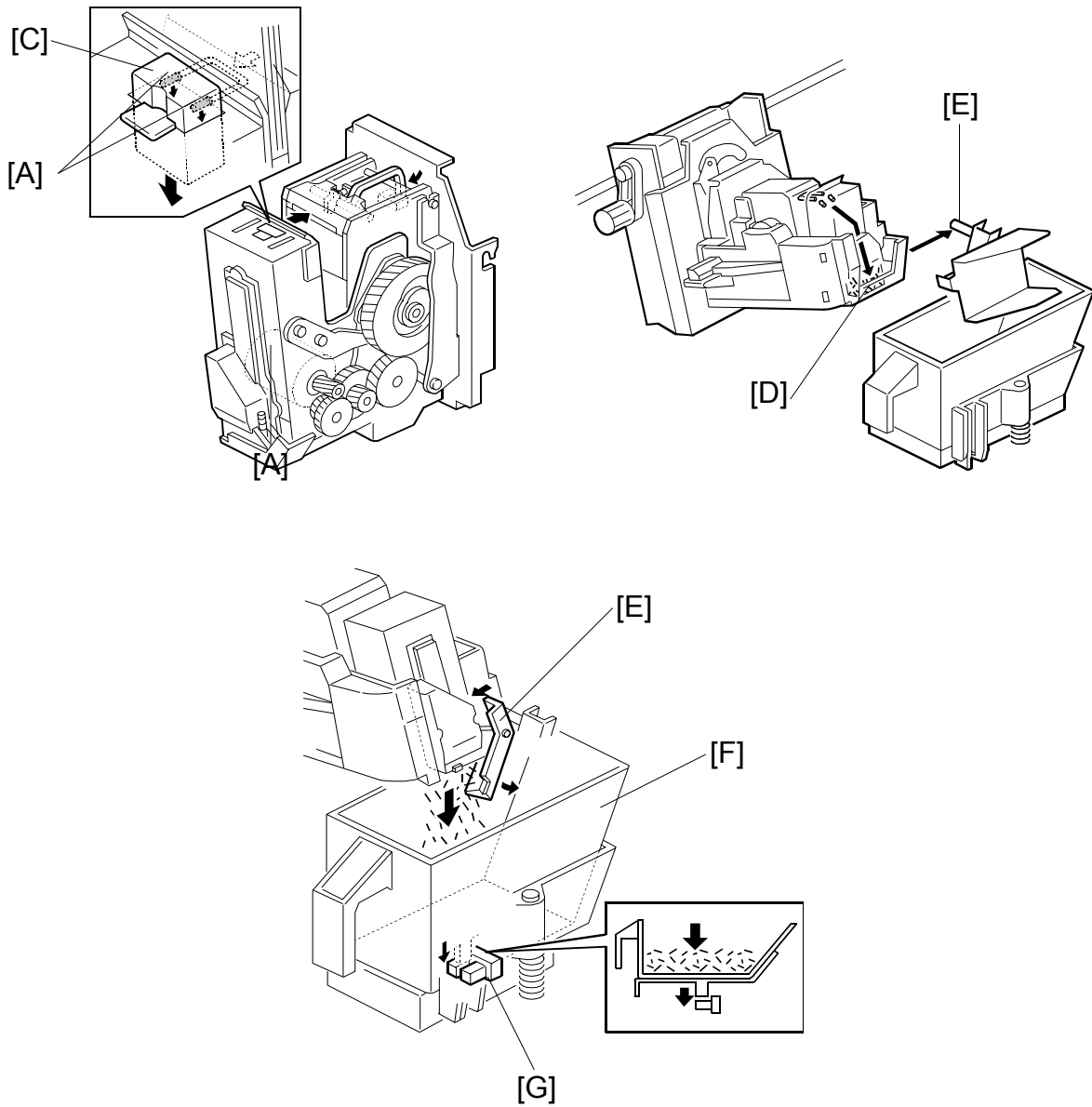

When the aligned copies are brought to the stapling position by the positioning roller and jogger fences, the staple hammer motor [A] starts stapling.

During stapling, the stapler trims off the excess length [B] of the staples by lowering the cutter [C]. This excess length depends on the number of copies in the set; there will be very little for a stack containing 100 sheets. The staple waste drops into the tray [D] in the stapler. When the stapler unit returns to its home position, the tray hits the shaft [E] and the tray opens. The staple waste drops into the staple waste hopper [F]. When the staple waste hopper is full, the actuator on its base activates the staple waste hopper sensor [G]. An SC737 (Full Finisher Staple Waste Hopper) is displayed.

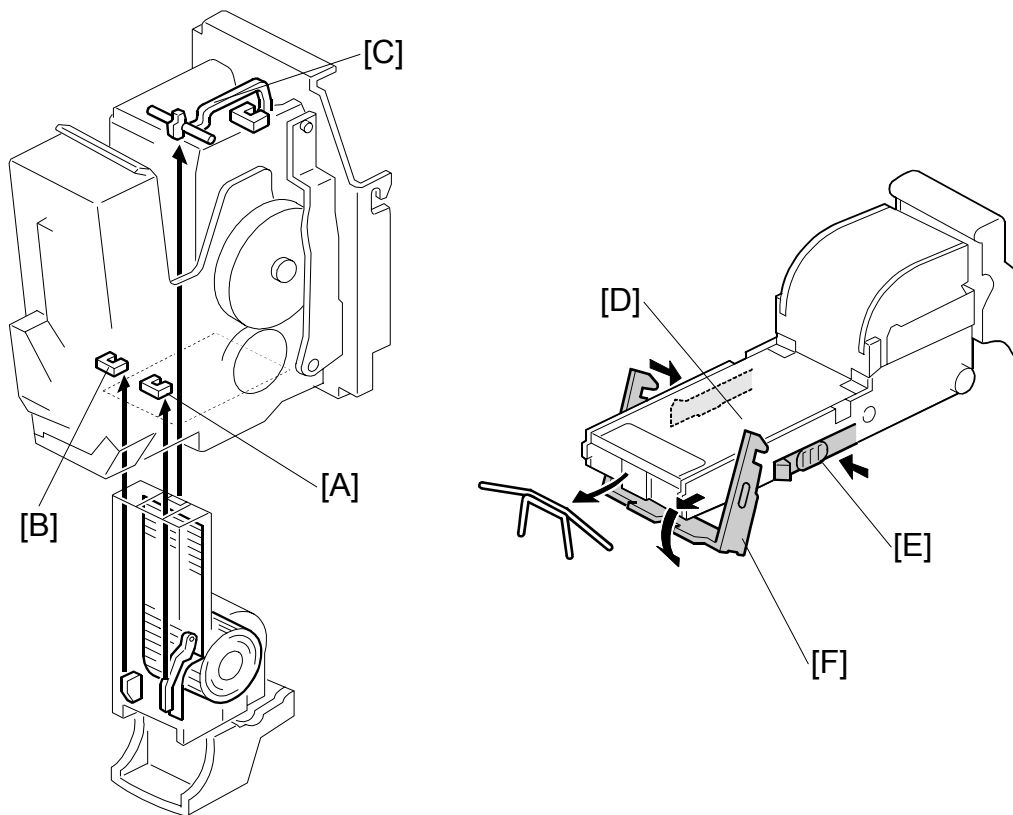

The stapler has a staple end sensor [A], cartridge set sensor [B] and staple hammer HP sensor [C].

When a staple end or no cartridge condition is detected, a message is displayed advising the operator to install a staple cartridge. If this condition is detected during a copy job, the indication will appear, and the copy job will stop.

The staple cartridge has a clinch area [D] where jammed staples collect. The operator can remove the jammed staples from the clinch area by pressing in the releases [E] on both sides, then lowering the bracket lever [F].

7.5.6 FEED-OUT

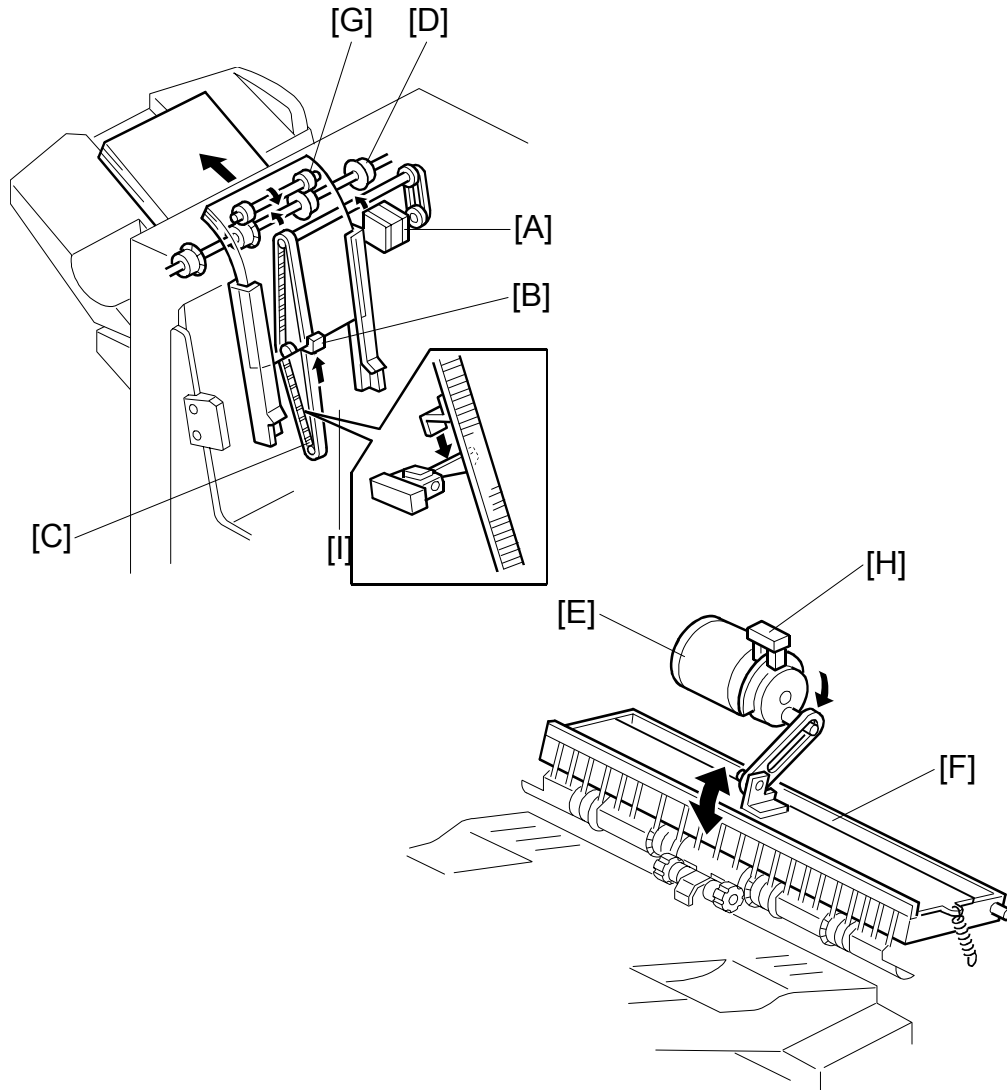

After the copies have been stapled, the stack feed-out motor [A] starts. The pawl [B] on the stack feed-out belt [C] transports the set of stapled copies up and feeds it to the shift tray exit roller [D]. When stapling starts, the exit guide motor [E] opens the upper exit guide [F], which includes the upper shift tray exit roller [G], in order to feed out the leading edge of the copy set smoothly. The exit guide motor turns on again a certain time after stapling is complete, and the upper exit guide plate is lowered. Then the shift tray exit roller takes over the stack feed-out.

The on-off timing of the exit guide motor is detected by the exit guide open sensor [H].

The stack-feed-out motor turns off when the pawl actuates the stack feed-out belt home position sensor [I].

7.5.7 PAPER EXIT STACKING

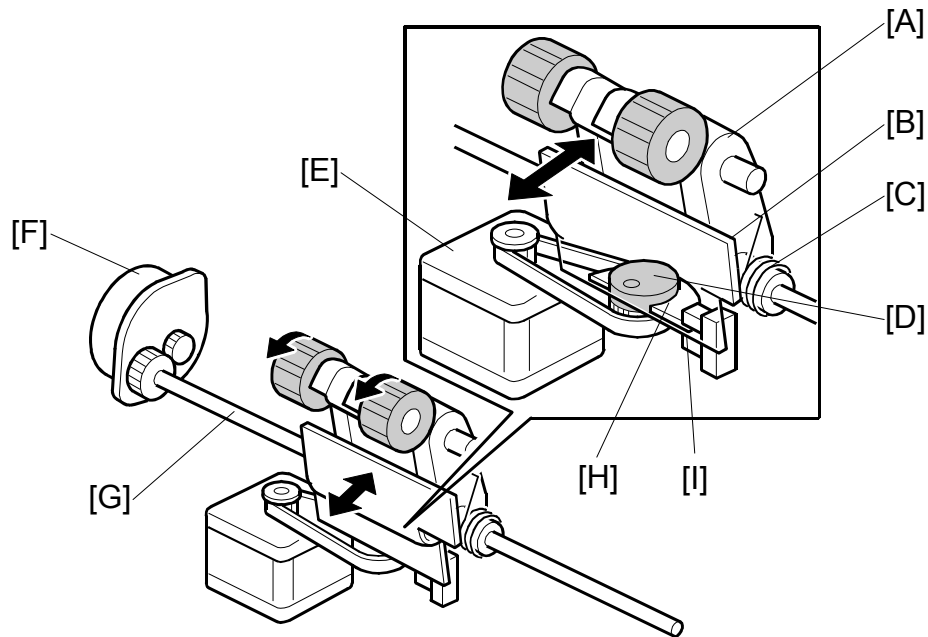

The stacking roller assembly [A] is fastened to a plate [B] on a shaft by a spring [C]. The cam [D], in contact with the bottom of the plate, is connected to the stacking roller drag motor [E] via a timing belt.

The stacking roller drag motor and timing belt rotate the cam against the bottom of the plate to move the rollers forward and back with each sheet ejected onto the shift tray.

The stacking roller motor [F] drives the shaft [G] that rotates the stacking rollers counter-clockwise as the rollers move back. The simultaneous rotation and backward movement of the roller assembly pulls each sheet back toward the copier to align the edges of the stack on the shift tray.

The actuator [H] is mounted on the cam and rotating with both rotating clockwise) and detects the roller assembly home position when the actuator leaves the gap of the return drive HP sensor [I] and signals the machine that the rollers are at the home position. The machine uses this information to control paper feed timing and confirm that the mechanism is operating correctly. The cam and actuator make one complete rotation for every sheet fed out of the machine onto the shift tray.

7.5.8 SHIFT TRAY

Overview

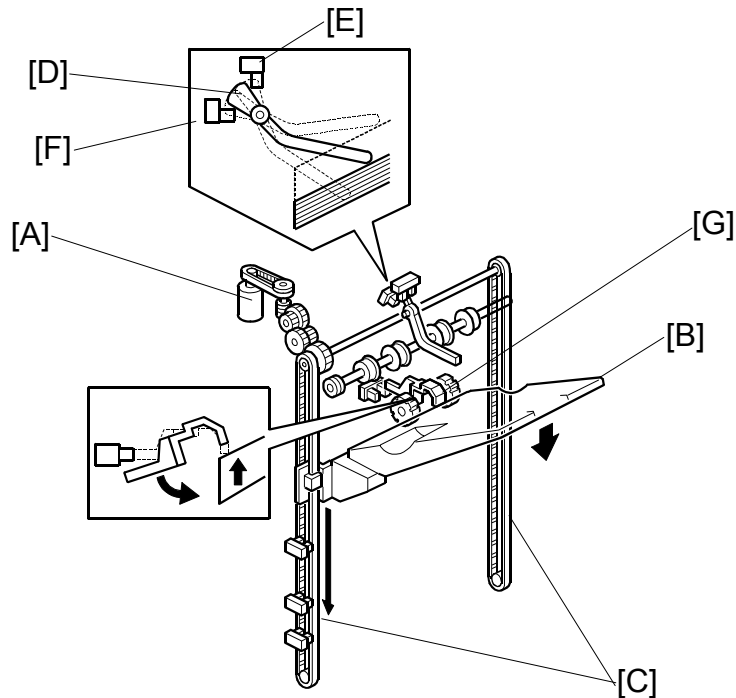

The shift tray lift motor [A] controls the vertical position of the shift tray [B] through gears and timing belts [C].

Stand-by Mode

After the main switch is turned on, or when the stack is removed from the tray, the end of the feeler on the tray falls and its actuator [D] rotates up into staple mode HP sensor 2 [E] (S7) and switches it on. This switches on the lift motor, which raises the tray until the tray pushes the actuator out of the sensor [E]. Then, the lift motor stops the shift tray; this is the home position (the actuator [D] is between the two sensors [E] and [F]).

The shift tray upper limit switch (SW1) prevents the drive gear from being damaged if stack height sensor 1 [E] fails. In case of a failure, when the shift tray pushes up the actuator [G] and positioning rollers, the switch will cut the power to the shift tray lift motor.

7.5.9 SHIFT TRAY UP/DOWN MOVEMENT

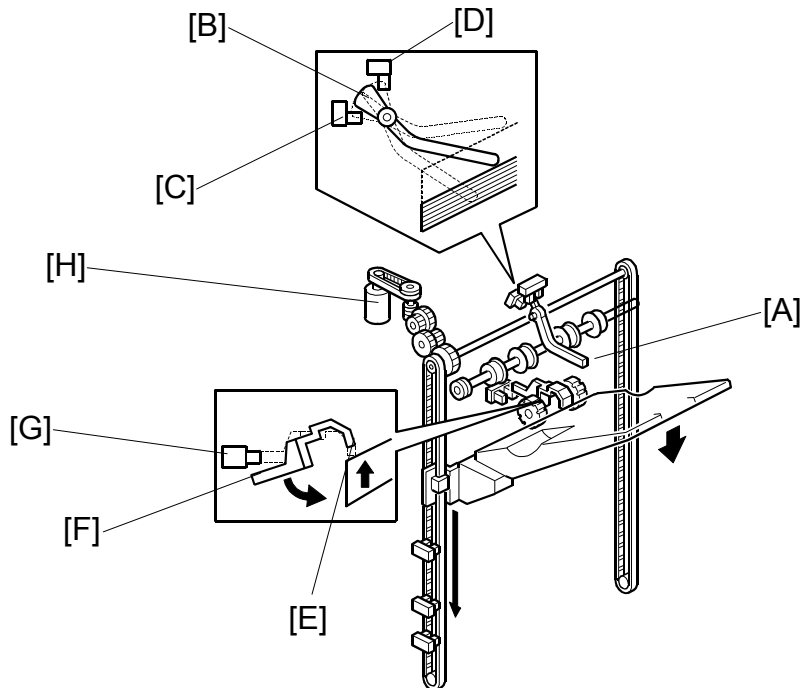

Sort/Stack Mode (Shift Mode)

The shift tray moves to home position, which is when the actuator [F] has just exited the shift mode home position sensor [G] (S12). During feed-out, the tray is lowered automatically at prescribed intervals; sensor [D] (S7) is ignored. When the stack is removed from the tray, the end of the feeler [E] between the arms of the stacking roller falls, and its actuator [F] enters sensor [G] (S12) and switches it on. This switches on the lift motor [H], which raises the tray until the actuator leaves the sensor. Then, the lift motor stops the tray; this is the home position.

In sort/stack mode, if S12 fails when the tray is being lifted, the shift tray upper limit switch (SW1) prevents the drive gear from being damaged.

Staple Mode

The shift tray moves to home position, which is when the actuator [B] is between the staple mode home position sensors [C] and [D]. During feed-out, the shift tray is lowered automatically at prescribed intervals. When the stack is removed from the tray, the tray returns to the home position for stand-by mode.

7.5.10 SHIFT TRAY LOWER LIMIT DETECTION

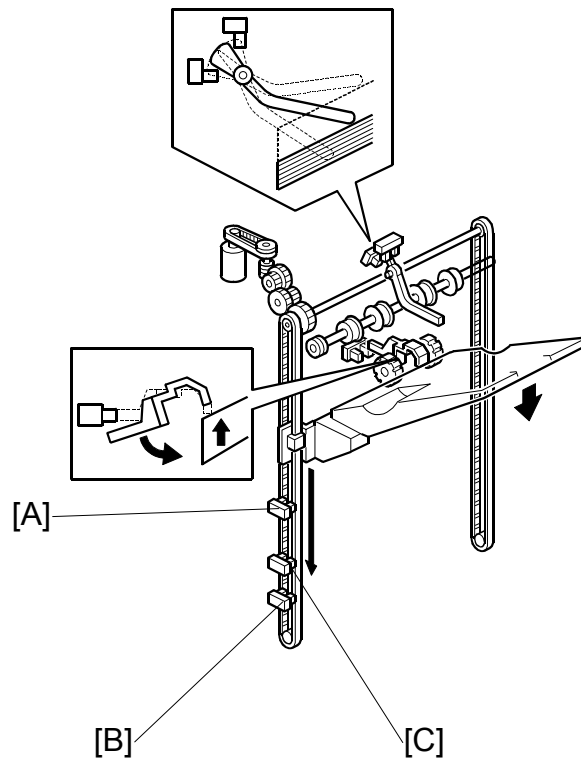

This machine has two shift tray lower limit sensors: shift lower limit sensor [A] (S9) for large paper (B4 and larger) and shift lower limit sensor [B] (S11) for small paper (smaller than B4).

NOTE: Sensor [C] (S10) is not used.

When the actuator [D] enters sensor [A] while using large paper (about 1500 sheets are on the tray), a message will be displayed and copying will stop.

When the actuator [D] enters sensor [B] while using small paper (about 3,000 sheets are on the tray), a message will be displayed and copying will stop.

7.5.11 SHIFT TRAY SIDE-TO-SIDE MOVEMENT

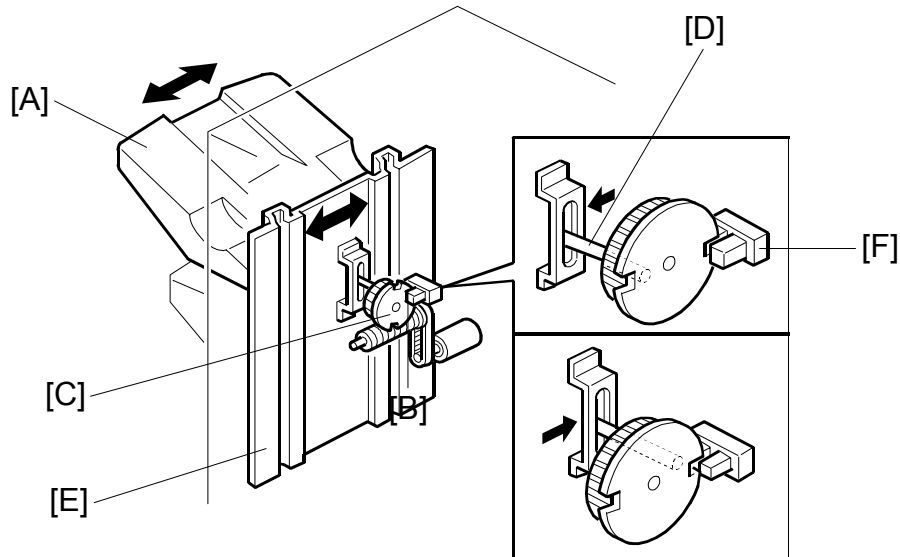

In sort/stack mode, the shift tray [A] moves from side to side to separate the sets of copies.

The horizontal position of the shift tray is controlled by the shift motor [B] and shift gear disk [C]. After one set of copies is made and delivered to the shift tray, the shift motor turns on, driving the shift gear disk and the shaft [D]. The end fence [E] is positioned by the shaft, creating the side-to-side movement.

When the shift gear disk has rotated 180 degrees (when the shift tray is fully shifted across), the cut-out in the shift gear disk turns on the shift tray half-turn sensor [F] and the shift motor stops. The next set of copies is then delivered. The motor turns on, repeating the same process and moving the tray back to the previous position.

7.6 JAM CONDITIONS

1. The entrance sensor does not turn on when the copier has fed paper 426 mm after the copier exit sensor turned off.
2. The entrance sensor does not turn off when the upper transport motor has fed paper 1.5 times the paper's length after it turned on.
3. The upper tray exit sensor does not turn on when the upper transport motor has fed paper 574 mm after the entrance sensor turned on.
4. The upper tray exit sensor does not turn off when the upper transport motor has fed paper 1.5 times the paper's length after it turned on.
5. In sort/stack mode, the shift tray exit sensor does not turn on when the upper transport motor has fed paper 733 mm after the entrance sensor turned on.
6. In sort/stack mode, the shift tray exit sensor does not turn off when the upper transport motor has fed paper 1.5 times the paper's length after it turned on.
7. In staple mode, the stapler tray entrance sensor does not turn on when the upper and lower transport motor have fed paper 835 mm after the entrance sensor turned on.
8. In staple mode, the stapler tray entrance sensor does not turn off when the upper transport motor has fed paper 1.5 times the paper's length after it turned on.
9. In staple mode, the stapler tray paper sensor does not turn off within 250 pulses of the stack feed-out motor after it started.
10. In staple mode, the shift tray exit sensor does not turn off within 1,260 ms after the stack feed-out motor started.

7.7 PUNCH UNIT B531 (OPTION)

7.7.1 PUNCH UNIT DRIVE

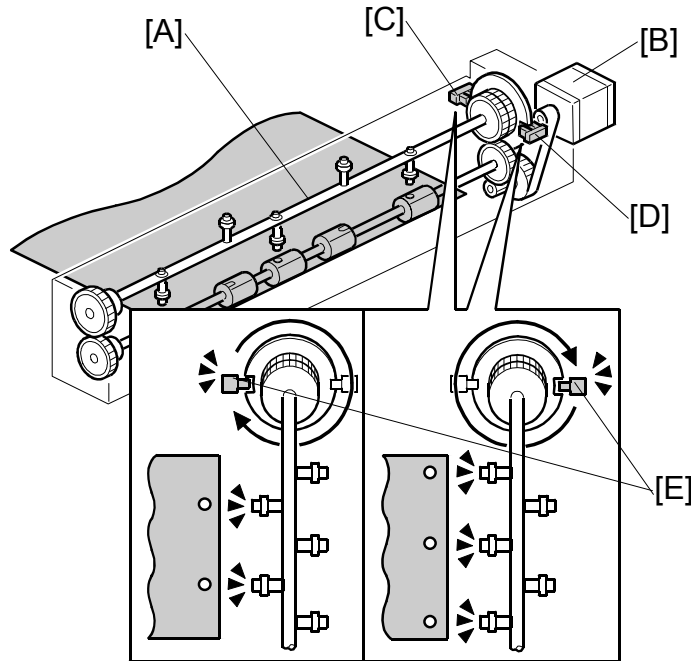

The punch unit makes 2 or 3 holes at the trailing edge of the paper. The number of holes depends on a selection made on the operation panel.

The cam [A] has 2 punches on one side and 3 punches on the other, and is turned by the punch motor [B]. The punch motor turns on immediately after the trailing edge of the paper passes the entrance sensor. The punches on the cam rotate downward and punch holes in the paper.

After punching a sheet of paper, the cam returns to home position and stops. Home position depends on whether 2 holes or 3 holes are being made, so there are two punch HP sensors. Punch HP sensor 1 [C] is used when 2-hole punching is selected, and punch HP sensor 2 [D] is used when 3-hole punching is selected. When the cut-out [E] enters the slot of the punch HP in use (sensor 1 or 2-hole punching or sensor 2 for 3-hole punching) the motor stops.

The knob (not shown) on the front end of the punch unit can be turned in either direction to clear paper jammed in the punch unit.

7.7.2 PUNCH WASTE COLLECTION

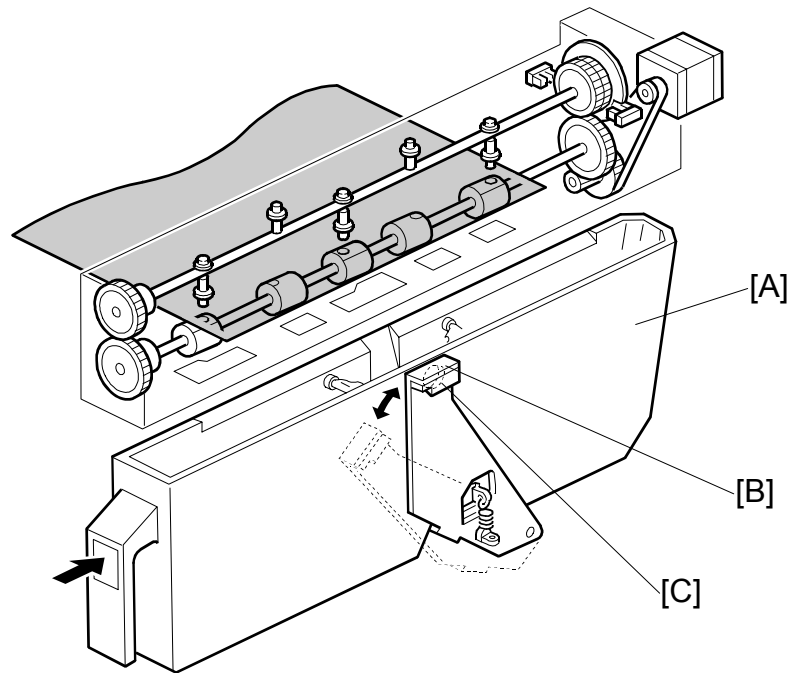

Punch waste is collected in the punch waste hopper [A] positioned under the punch unit.

When the level of the punch waste in the hopper rises as far as the hole [B] in the hopper, the punch waste sensor [C] turns on, stops the job, and triggers a message on the operation to indicate that the hopper is full and must be removed and emptied.

The job resumes automatically after the hopper is emptied and returned to the finisher.

The punch waste hopper sensor also functions as the hopper set sensor. When the hopper is not in the finisher, or if it is not inserted completely, the spring loaded sensor arm rotates up and to the right with the punch waste sensor away from the hole in the hopper holder and a message is displayed. The message in this case is the same as the hopper full message.

7.8 JOGGER UNIT B513 (OPTION)

7.8.1 JOGGER UNIT MECHANICAL LAYOUT

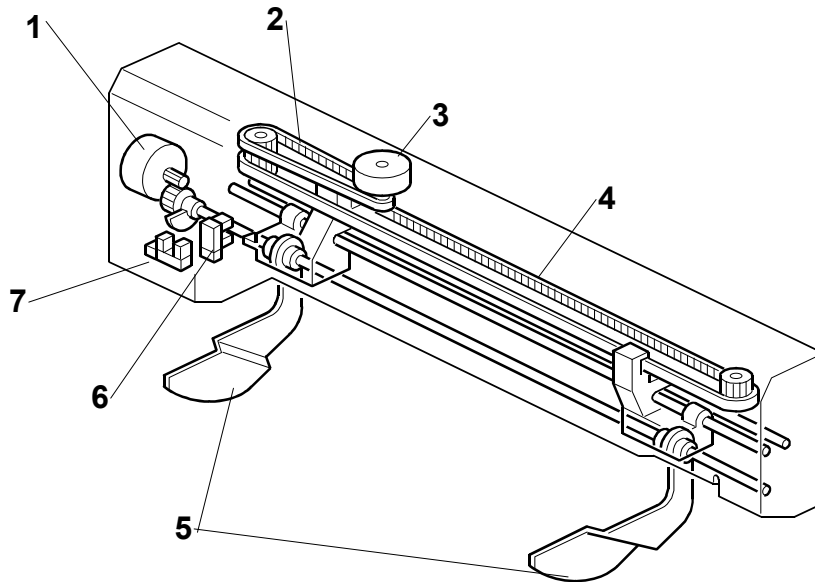

1. Shift Jogger Fence Lift Motor
2. Shift Jogger Motor Timing Belt
3. Shift Jogger Motor
4. Shift Jogger Fence Timing Belt
5. Shift Jogger Fences
6. Shift Jogger HP Sensor
7. Shift Jogger Lift HP Sensor

7.8.2 JOGGER UNIT DRIVE

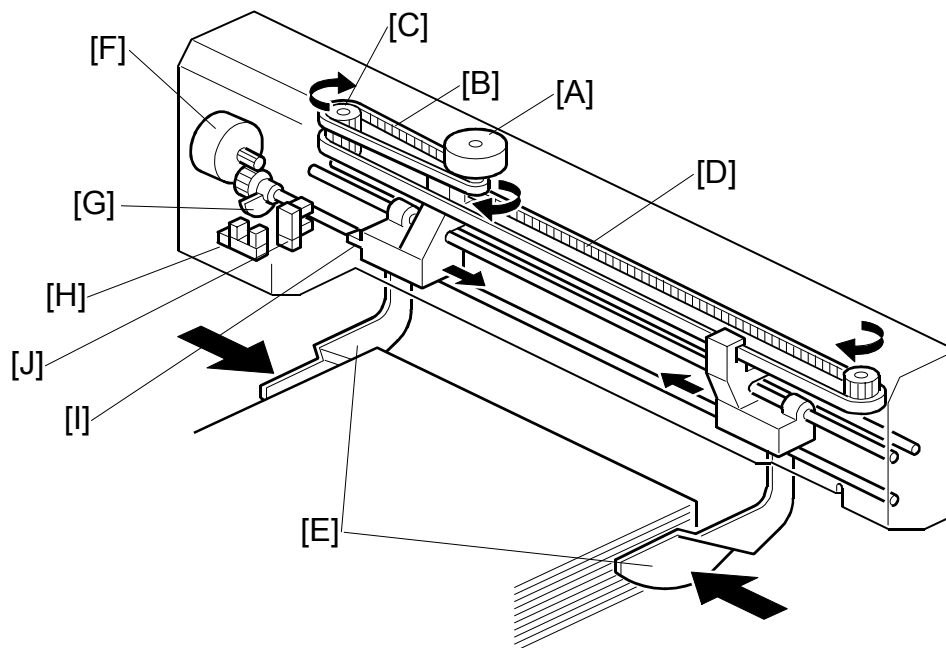

At prescribed intervals, the jogger motor [A] switches on and drives the jogger timing belt [B], gear [C] and jogger fence timing belt [D] which drives the shift jogger fences [E] against the sides of the stack to align its edges.

At the end of the job, the jogger fence lift motor [F] switches on and raises the fences until the actuator [G] leaves the slot of the shift jogger fence lift HP sensor [H] and shuts off the shift jogger fence lift motor.

At the same time, the jogger motor reverses and drives the fences away from the sides of the stack until the actuator [I] deactivates the shift jogger fence HP sensor [J] and switches off the jogger motor.

The jogger fences remain up in the standby position until the next job starts.

SECTION 8
COVER INTERPOSER TRAY
MJ-7002

8. COVER INTERPOSER TRAY TYPE 1075 (B470)

8.1 SPECIFICATION

Paper Separation	FRR System with Feed Belt
Paper Sizes	A3 ~ A5, 11" x 17" ~ 5 1/2" x 8 1/2"
Paper Weight	64 ~ 216 g/m ²
Capacity	200 sheets (80 g/m ²)
Power Supply (from main machine)	24 V ±10%, 5 V ±5% (From Finisher)
Power Consumption	Less than 48 W
Dimensions (W x D x H)	500 x 620 x 200 mm 19.7" x 24.4" x 7.9"
Weight	Less than 12 kg (26.4 lb.)

8.2 OVERALL MACHINE INFORMATION

8.2.1 MAIN LAYOUT

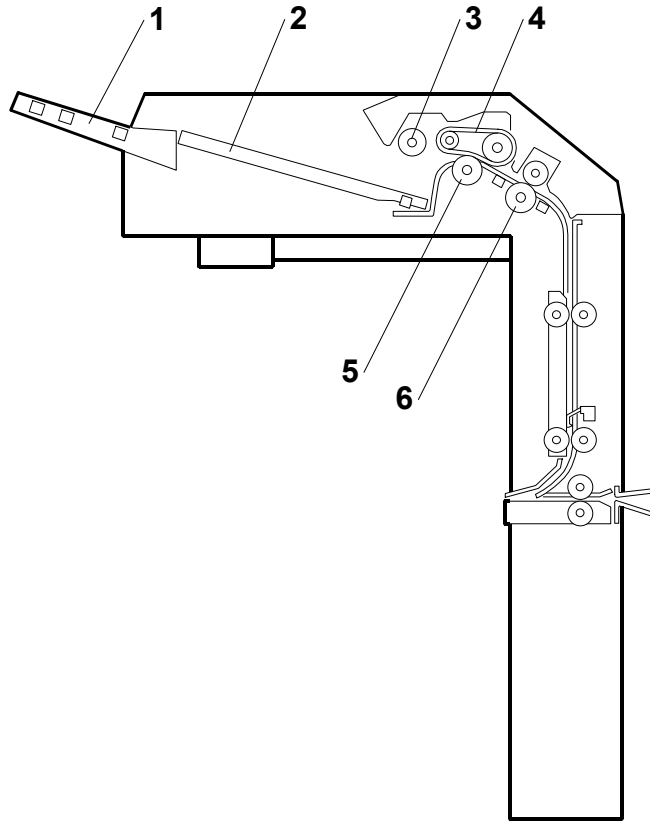

1. Support tray
2. Slip sheet tray
3. Pick-up roller
4. Feed belt
5. Separation roller
6. Grip roller

8.2.2 DRIVE LAYOUT

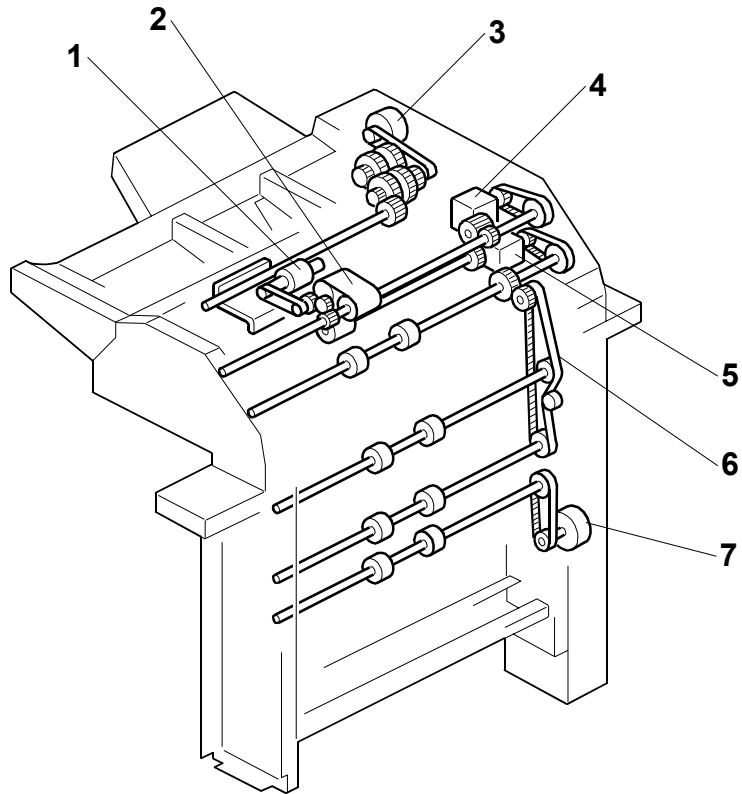

1. Pick-up Roller
2. Feed Belt
3. Bottom Plate Lift Motor
4. Feed Motor
5. Transport Motor
6. Timing Belt
7. Vertical Transport Motor

8.3 DETAILED DESCRIPTIONS

8.3.1 PAPER PATH

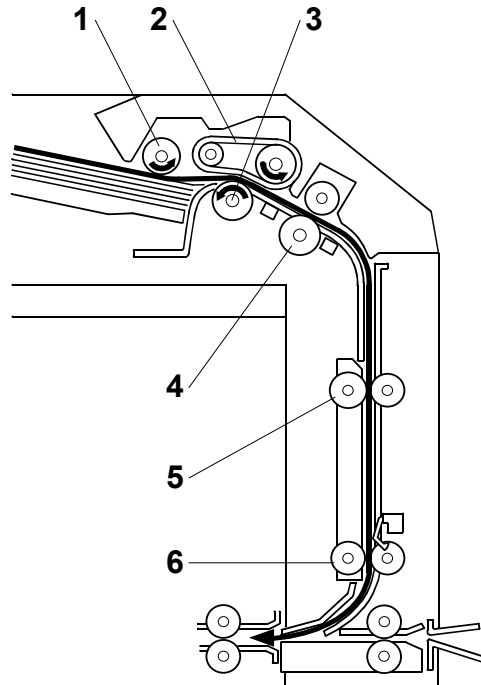

1. Pick-up Roller
2. Feed Belt
3. Separation Roller
4. Grip Roller
5. Transport Roller 1
6. Transport Roller 2

The paper feeds from the tray, to the feed belt, then to the grip roller and down into the paper path to the finisher below.

8.3.2 PAPER FEED

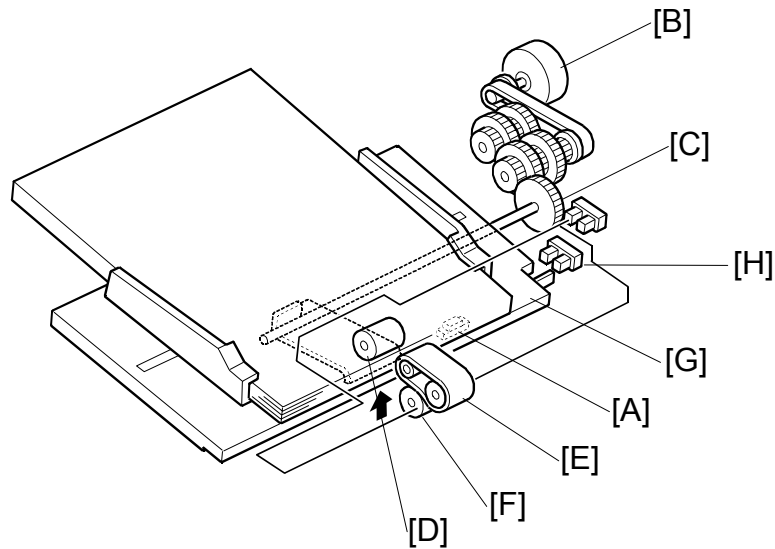

Power On

When paper is placed on the tray, the paper set sensor [A] in the tray actuates and switches on the bottom plate lift motor [B]. The top of the stack raises the pick-up roller unit until the actuator on this unit actuates the pick-up roller position sensor [C] and switches the motor off.

Paper Separation and Feed

The pick-up roller [D] picks up the original, and the feed belt [E] feeds the sheet to the grip roller. The separation roller [F] reverses if more than one sheet is fed

Bottom Tray Lift

As sheets feed from the top of the stack:

- The pick-up roller unit descends until the actuator on the pick-up roller unit drops out of the pick-up roller position sensor [C].
- The bottom plate lift motor switches on to raise the stack until the actuator enters the pick-up roller unit position sensor again and switches the motor off.
- This repeats until the end of the job or until paper runs out.

Paper Near-end

Near-end is detected when the actuator [G] on the bottom plate enters the near-end sensor [H]

Paper End

After the last sheet feeds the paper set sensor [A] goes off and signals paper out.

8.3.3 PAPER SIZE DETECTION

The width sensors [A] (S1, S2, S3) and length sensors [B] (S4, S5, S6) detect the width and length of the paper on the interposer feed tray.

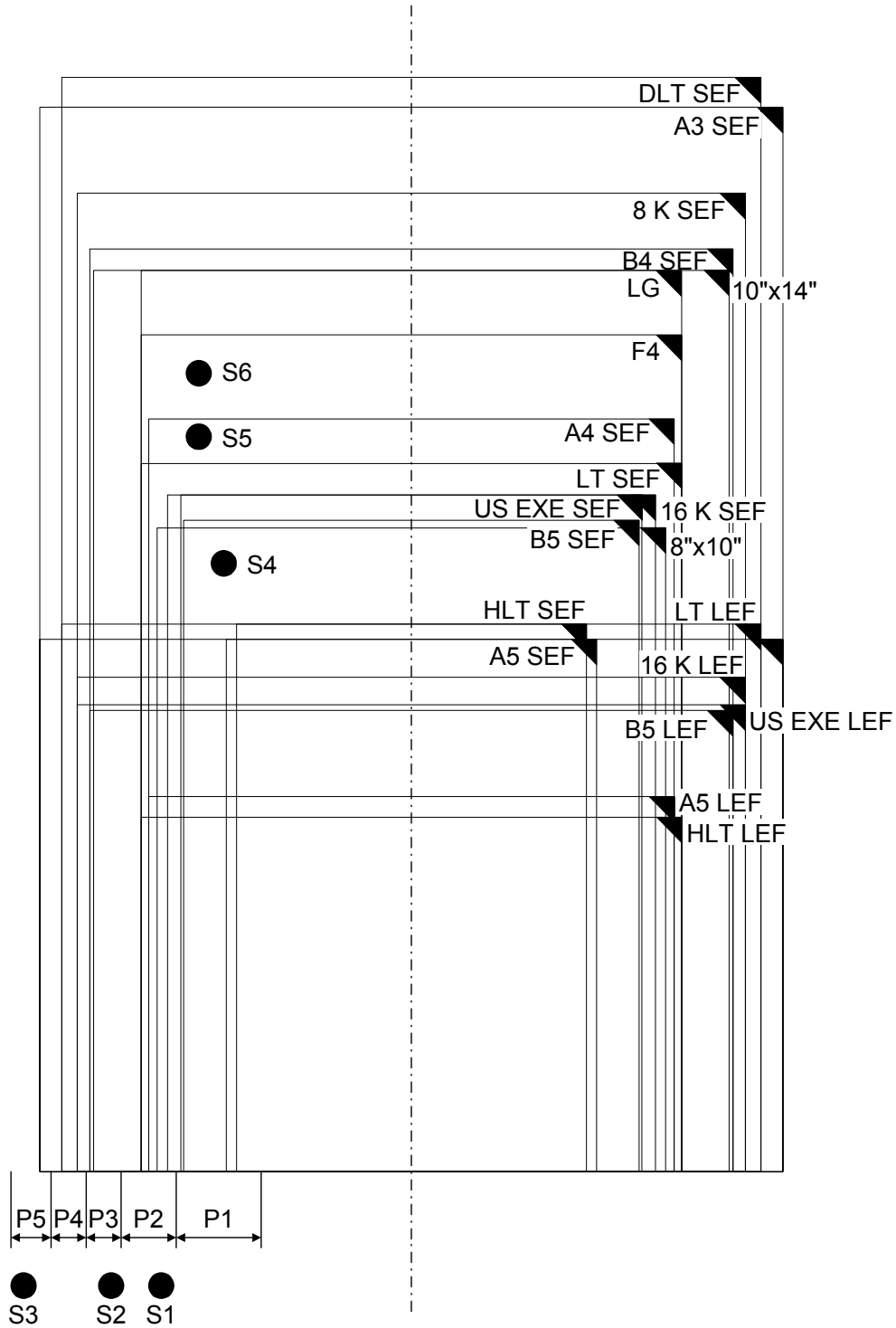

The table below lists the sensor output for each paper size.

	S1	S2	S3	S4	S5	S6
A3	0	1	1	1	1	1
B4	1	1	0	1	1	1
A4 SEF	1	0	0	1	1	0
A4 LEF	0	1	1	0	0	0
B5 SEF	0	0	0	1	0	0
B5 LEF	1	1	0	0	0	0
A5 SEF	0	0	0	0	0	0
A5 LEF	1	0	0	0	0	0
11" x 17"	1	1	1	1	1	1
10" x 14" SEF	1	1	0	1	1	1
8 1/2" x 14"	1	0	0	1	1	1
8 1/2" x 13"	1	0	0	1	1	1
8 1/2" x 11"	1	0	0	1	0	0
11" x 8 1/2"	1	1	1	0	0	0
8" x 10"	1	0	0	1	0	0
5 1/2" x 8 1/2"	0	0	0	0	0	0
8 1/2" x 5 1/2"	1	0	0	0	0	0
7 1/2" x 10 1/2" (US Exec.)	0	0	0	1	0	0
10 1/2" x 7 1/2" (US Exec.)	1	1	1	0	0	0
8 K	1	1	1	1	1	1
16 K SEF	1	0	0	1	0	0
16 K LEF	1	1	1	0	0	0

The cover interposer tray detects all the paper sizes listed above. However, there are some limitations on the display of the correct paper size.

		North America	Europe/Asia
B4 SEF	257 x 364 mm	Displays 10" x 14" ^{*1}	
B5 SEF	182 x 257	Displays "US Exec." ^{*1}	
A5 SEF	148 x 210	Displays "HLT SEF" ^{*1}	
A5 LEF	210 x 148	Displays "HLT LEF" ^{*1}	
DLT SEF	11" x 17"		Displays "8K LEF" ^{*2}
LG SEF	8 1/2" x 14"		Displays "F4 SEF" ^{*2}
LT SEF	8 1/2" x 11"		Displays "16 K SEF" ^{*2}
LT LEF	11" x 8 1/2"		Displays "16 K LEF" ^{*2}

^{*1}: Cannot be corrected.

^{*2}: B064/B065: Can be corrected with SP5959 006 (Paper Size – Cover Sheet).

B064/B065: Correct Paper Size Display

North America

Execute SP5959 006 and enter the correct number for the size of the paper loaded for feeding from the cover interposer tray.

Loaded	Display (Default)	To Select for Display	Enter
8 1/2" x 13"	8 1/2" x 14"	8 1/2" x 13"	165
10 1/2" x 7 1/2"	8 1/2" x 11"	10 1/2" x 7 1/2"	173
8" x 10"	8 1/2" x 11"	8" x 10"	171

Europe/Asia

Execute SP5959 006 and enter the correct number for the size of the paper loaded for feeding from the cover interposer tray.

Loaded	Display (Default)	To Select for Display	Enter
11" x 17"	8 K	11" x 17"	160
8 1/2" x 11"	16 K SEF	8 1/2" x 11"	166
11" x 8 1/2"	16 K LEF	11" x 8 1/2"	38
8 1/4" x 13"	8 1/2" x 13" SEF	8 1/4" x 13"	168

B070/B071: Paper Size Detection

Some paper sizes are almost the same and cannot be distinguished by the sensors. To determine which sizes are detected, use SP 5158.

SECTION 9
MULTI BYPASS TRAY
MY-1024

9. MULTI BYPASS TRAY TYPE 2105 (B512)

9.1 SPECIFICATION

NOTE: The Bypass Tray is attached to the top of the LCT B511.

Paper Feed System	FRR
Tray Capacity	500 sheets (Thick Paper 0.11 mm)
Remaining Paper Detection	4-Step: Including Near-End
Paper Size	A5 to A3, 5 1/2" x 8 1/2" to 12" x 18"
Tab Sheets	A4 LEF, 8 1/2" x 11" LEF (requires attachment of tab fence)
Paper Weight	52 to 216 g/m ²
Weight	Less than 18 kg (39.6 lb.)
Power Source	24 Vdc, 5 Vdc (from copier)
Power Consumption	50 W
Dimensions (W x D x H)	680 x 561 x 181 mm (26.7 x 21.1 x 7.1 in.)

9.2 OVERALL MACHINE INFORMATION

9.2.1 MECHANICAL COMPONENT LAYOUT

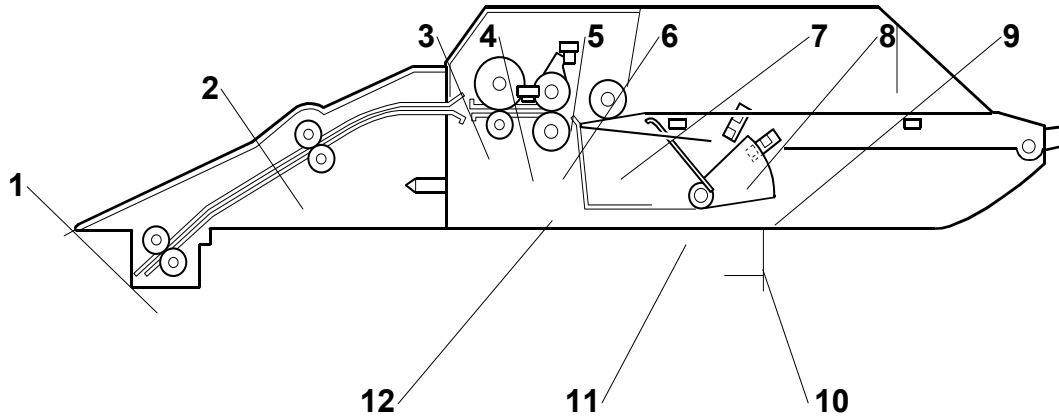

1. Transport Roller 2
2. Transport Roller 1
3. Grip Roller
4. Paper Feed Sensor
5. Lift Sensor
6. Feed Roller
7. Pick-up Roller
8. Paper Height Sensor 1
9. Paper Height Sensor 2
10. Lift Plate Actuator
11. Lift Plate
12. Separation Roller

9.3 ELECTRICAL COMPONENT LAYOUT

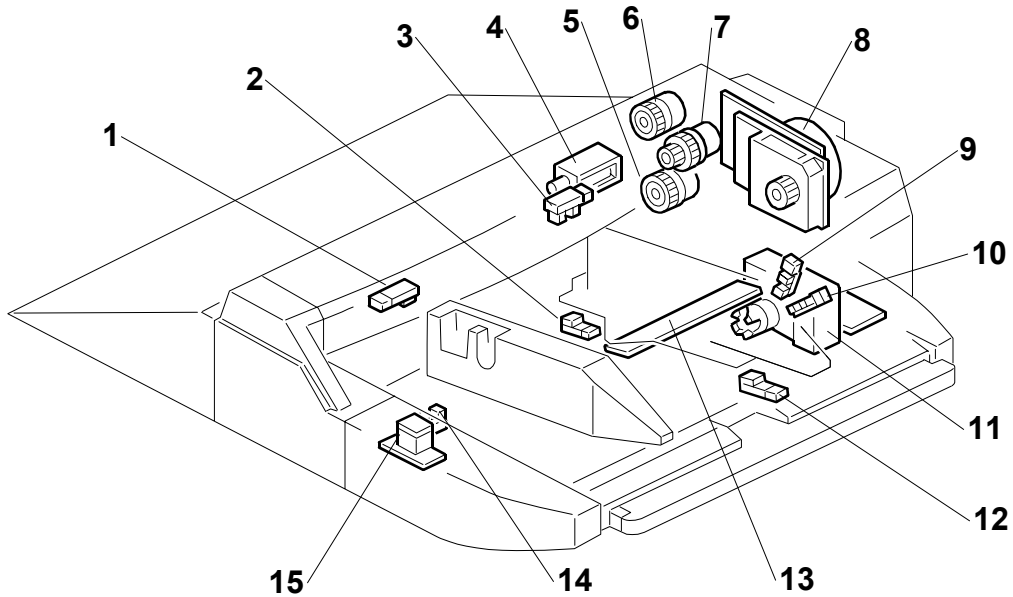

1. Paper Feed Sensor
2. Paper End Sensor
3. Lift Sensor
4. Pick-up Solenoid
5. Transport Clutch
6. Grip Clutch
7. Feed Clutch
8. Tray Motor
9. Paper Height Sensor 1
10. Paper Height Sensor 2
11. Lift Motor
12. Paper Length Sensor
13. Paper Width Switch
14. Lower Limit Sensor
15. Tray Lift Switch

9.3.1 ELECTRICAL COMPONENT DESCRIPTIONS

Symbol	Name	Function
Clutches		
MC8	Transport	Drives the transport rollers in the bypass tray.
MC9	Paper Feed	Drives the paper feed roller in the bypass tray.
MC10	Grip	Drives the grip clutch in the bypass tray.
Motors		
M5	Tray	Drives all rollers in the bypass tray.
M6	Tray Lift	Lifts and lowers the tray.
Sensors		
S23	Paper Feed	Detects the copy paper coming to the paper feed roller and checks for misfeeds.
S24	Lift	Detects when the paper in the bypass tray is at the correct paper feed height.
S25	Lower Limit	Detects when the tray is at its lowest possible position.
S26	Paper End	Informs the copier when the paper in the bypass tray has run out.
S27	Paper Length	Used with the paper width switch to determine paper size. This sensor is activated when paper is set for short edge feed. For example, when the paper width switch detects A4 width and this sensor is off, the machine determines A4 is set for long edge feed. When A4 width is detected and the paper length sensor is on, then the machine determines that A3 is loaded for short edge feed.
S28	Paper Height 1	Detects the paper height in the bypass tray.
S29	Paper Height 2	Detects the paper height in the bypass tray.
Solenoids		
SOL7	Pick-up	Controls up-down movement of the pick-up roller in the bypass tray.
Switches		
SW5	Tray Lift	Switches the tray lift motor on and off to lift and lower the bottom plate of the tray. This switch must be pressed to start paper feed.
SW6	Paper Width	A slide switch connected to the side fences. When the side fences are moved to match the paper width, four feelers inside the paper size switch slide along wiring patterns of a terminal plate. The wire pattern detected determines the paper width.

The numbering for the components does not start at 1 because the point-to-point diagram for the bypass tray is included on the diagram for the LCT. For the purpose of component numbering, they are considered together as one unit.

9.4 DRIVE LAYOUT

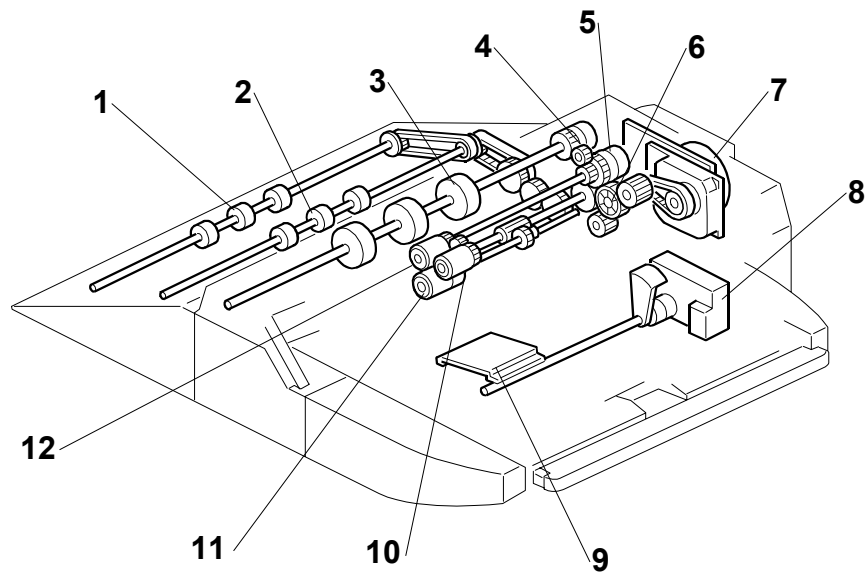

1. Transport Roller 2
2. Transport Roller 1
3. Grip Roller
4. Grip Clutch
5. Paper Feed Clutch
6. Transport Clutch
7. Tray Motor
8. Lift Motor
9. Lift Plate
10. Pick-up Roller
11. Separation Roller
12. Feed Roller

9.5 DETAILED DESCRIPTIONS

9.5.1 PAPER PATH

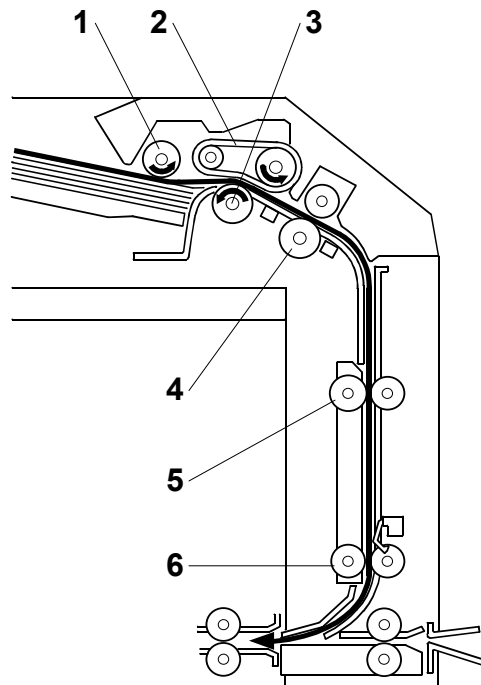

1. Pick-up Roller
2. Feed Belt
3. Separation Roller
4. Grip Roller
5. Transport Roller 1
6. Transport Roller 2

The paper feeds from the tray, to the feed belt, then to the grip roller and down into the paper path to the finisher below.

9.5.2 PAPER FEED

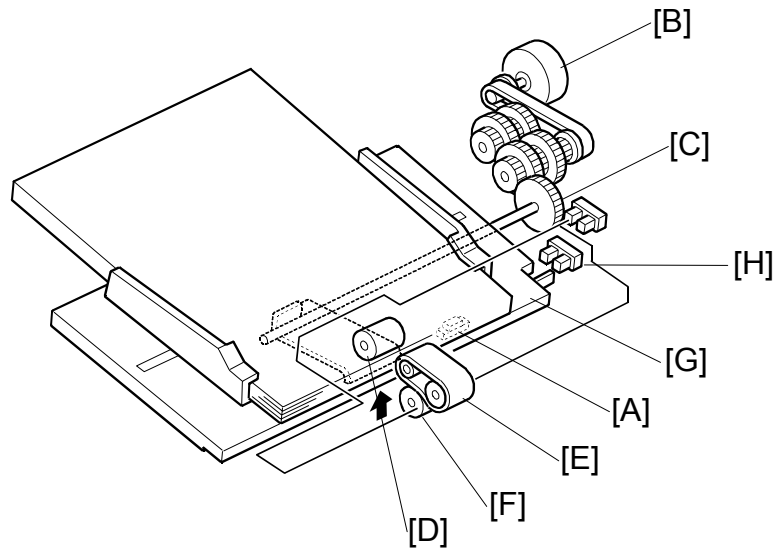

Power On

When paper is placed on the tray, the paper set sensor [A] in the tray actuates and switches on the bottom plate lift motor [B]. The top of the stack raises the pick-up roller unit until the actuator on this unit actuates the pick-up roller position sensor [C] and switches the motor off.

Paper Separation and Feed

The pick-up roller [D] picks up the original, and the feed belt [E] feeds the sheet to the grip roller. The separation roller [F] reverses if more than one sheet is fed

Bottom Tray Lift

As sheets feed from the top of the stack:

- The pick-up roller unit descends until the actuator on the pick-up roller unit drops out of the pick-up roller position sensor [C].
- The bottom plate lift motor switches on to raise the stack until the actuator enters the pick-up roller unit position sensor again and switches the motor off.
- This repeats until the end of the job or until paper runs out.

Paper Near-end

Near-end is detected when the actuator [G] on the bottom plate enters the near-end sensor [H]

Paper End

After the last sheet feeds the paper set sensor [A] goes off and signals paper out.

9.5.3 PAPER SIZE DETECTION

The width sensors [A] (S1, S2, S3) and length sensors [B] (S4, S5, S6) detect the width and length of the paper on the interposer feed tray.

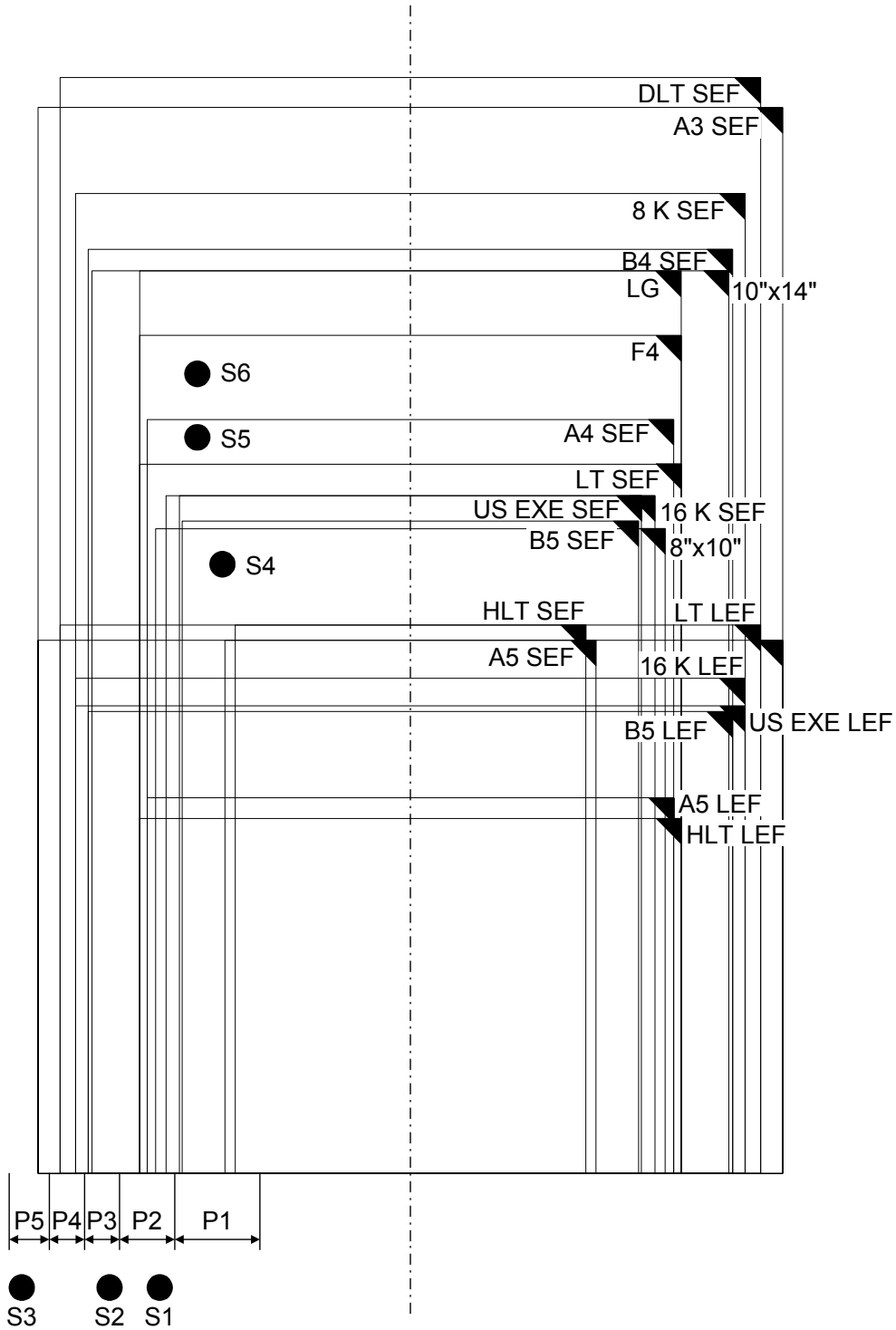

The table below lists the sensor output for each paper size.

	S1	S2	S3	S4	S5	S6
A3	0	1	1	1	1	1
B4	1	1	0	1	1	1
A4 SEF	1	0	0	1	1	0
A4 LEF	0	1	1	0	0	0
B5 SEF	0	0	0	1	0	0
B5 LEF	1	1	0	0	0	0
A5 SEF	0	0	0	0	0	0
A5 LEF	1	0	0	0	0	0
11" x 17"	1	1	1	1	1	1
10" x 14" SEF	1	1	0	1	1	1
8 1/2" x 14"	1	0	0	1	1	1
8 1/2" x 13"	1	0	0	1	1	1
8 1/2" x 11"	1	0	0	1	0	0
11" x 8 1/2"	1	1	1	0	0	0
8" x 10"	1	0	0	1	0	0
5 1/2" x 8 1/2"	0	0	0	0	0	0
8 1/2" x 5 1/2"	1	0	0	0	0	0
7 1/2" x 10 1/2" (US Exec.)	0	0	0	1	0	0
10 1/2" x 7 1/2" (US Exec.)	1	1	1	0	0	0
8 K	1	1	1	1	1	1
16 K SEF	1	0	0	1	0	0
16 K LEF	1	1	1	0	0	0

The cover interposer tray detects all the paper sizes listed above. However, there are some limitations on the display of the correct paper size.

		North America	Europe/Asia
B4 SEF	257 x 364 mm	Displays 10" x 14" ^{*1}	
B5 SEF	182 x 257	Displays "US Exec." ^{*1}	
A5 SEF	148 x 210	Displays "HLT SEF" ^{*1}	
A5 LEF	210 x 148	Displays "HLT LEF" ^{*1}	
DLT SEF	11" x 17"		Displays "8K LEF" ^{*2}
LG SEF	8 1/2" x 14"		Displays "F4 SEF" ^{*2}
LT SEF	8 1/2" x 11"		Displays "16 K SEF" ^{*2}
LT LEF	11" x 8 1/2"		Displays "16 K LEF" ^{*2}

^{*1}: Cannot be corrected.

^{*2}: B064/B065: Can be corrected with SP5959 006 (Paper Size – Cover Sheet).

B064/B065: Correct Paper Size Display

North America

Execute SP5959 006 and enter the correct number for the size of the paper loaded for feeding from the cover interposer tray.

Loaded	Display (Default)	To Select for Display	Enter
8 1/2" x 13"	8 1/2" x 14"	8 1/2" x 13"	165
10 1/2" x 7 1/2"	8 1/2" x 11"	10 1/2" x 7 1/2"	173
8" x 10"	8 1/2" x 11"	8" x 10"	171

Europe/Asia

Execute SP5959 006 and enter the correct number for the size of the paper loaded for feeding from the cover interposer tray.

Loaded	Display (Default)	To Select for Display	Enter
11" x 17"	8 K	11" x 17"	160
8 1/2" x 11"	16 K SEF	8 1/2" x 11"	166
11" x 8 1/2"	16 K LEF	11" x 8 1/2"	38
8 1/4" x 13"	8 1/2" x 13" SEF	8 1/4" x 13"	168

B070/B071: Paper Size Detection

Some paper sizes are almost the same and cannot be distinguished by the sensors. To determine which sizes are detected, use SP 5158.

Free Manuals Download Website

<http://myh66.com>

<http://usermanuals.us>

<http://www.somanuals.com>

<http://www.4manuals.cc>

<http://www.manual-lib.com>

<http://www.404manual.com>

<http://www.luxmanual.com>

<http://aubethermostatmanual.com>

Golf course search by state

<http://golfingnear.com>

Email search by domain

<http://emailbydomain.com>

Auto manuals search

<http://auto.somanuals.com>

TV manuals search

<http://tv.somanuals.com>