

## Introduction

The electromagnetic flowmeter uses Faraday's Law of electromagnetic induction to measure the process flow. The device consists of two units: a detector, through which the fluid to be measured flows and in which low-level signals proportional to flow rates are obtained; and a converter, which supplies excitation current to the detector, and amplifies the signals from the detector and then processes and converts the signals into the 4–20 mA dc current signal. The LF470 is a small meter size detector designed to measure a small amount of fluids containing substances such as chemicals.

The wetted materials for the LF470 are corrosion resistant ceramic and platinum electrodes and are applicable to almost any kind of fluids. The LF470 is a lightweight palm-sized detector. Combined with multi-functional converter LF612 (separate type) and LF232\*<sup>1</sup> (separate type) equipped with its patented **Noise-Sentry** original noise-suppression circuit and advanced algorithms. The LF470 is highly resistant to noise and provides a stable output even for fluids containing slurries. IR (Infrared) switches enable parameter setting of the converter without removing the cover. Flow direction can be set in either way, and its unique 128 x 128 dot matrix LCD display allows the LCD to be rotated electronically to be rotated to 90, 180 and 270 degrees without opening the cover. The AF900 hand-held terminal (HART\*<sup>2</sup> communicator) can be used to communicate with the flowmeter from a remote place. PROFIBUS-PA\*<sup>3</sup> interface is available as an option.

\*1: Please refer to the document "TIC-LF232".

\*2: HART protocol (Highway Addressable Remote Transducer) is a communication protocol for industrial sensors recommended by the HCF (HART Communication Foundation).

\*3: PROFIBUS is the communication protocol for factory and process automation that the PROFIBUS Organization recommends. Instead of analog control with a conventional analog signal (4-20mA), it is the fieldbus which digitizes all signals. Flowmeters support PROFIBUS-PA.

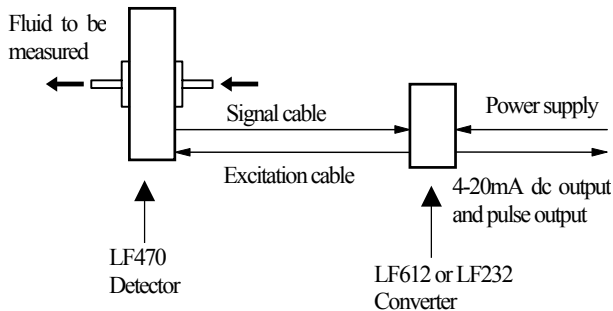

**Figure 1. Configuration Diagram**



**LF470 LF612**  
**Figure 2. Electromagnetic Flowmeter LF470/LF612**



Certification number  
Z01207

## Specifications

### ■ Overall Specifications

**Measurement range in terms of flow velocity:**  
0–1.0ft/s to 0–32.8ft/s (0–0.3 m/s to 0–10 m/s)

**Accuracy:** The overall accuracy combined with the LF612 or LF232 converter is shown in the following table.

Flow rate as a percent of range	Accuracy	
	1.0-3.3ft/s (0.3-1.0m/s)	3.3-32.8ft/s (1.0-10m/s)
50 ~ 100%	± 0.8% of FS	± 0.8% of rate
0 ~ 50%	± 0.8% of FS	± 0.4% of FS

**Note:** The accuracy is measured under standard operating conditions at Toshiba's calibration facility.

**Fluid conductivity:** 50µS/cm minimum

**Fluid temperature:**

Pipe connection material	Fluid temperature
Stainless steel and other metals	14 to 248 °F ( - 10 ~ + 120 )
Polyvinyl chloride (shock-resistant)	14 to 140 °F ( - 10 ~ + 60 )

**Ambient temperature:** 14 to 140 °F (–10 to +60 °C)

**Structure:** IP67

**Power consumption:**

- When combined with the LF612 converter: approximately 12W (20VA)
- When combined with the LF232 converter: approximately 14W (25VA)

**TIC-LF470B**

## ■ Model LF470 Detectors

**Fluid pressure:** -15 to 150 psi, or -1.0 to 10 bar  
(-0.1 to 1 MPa)

### Principal materials:

**Measurement tube** – Alumina ceramics

**Electrodes** – Platinum

### Pipe connection port:

Standard – 316 stainless steel

Option – Ti (titanium),  
Polyvinyl chloride (shock-resistant)+  
Ta (Tantalum) for grounding plate,  
Polyvinyl chloride (shock-resistant)+  
Pt-Ir grounding plate,  
Hastelloy C (Equivalent)

### Dedicated preformed cables:

- Signal cable – 2-wire shielded chloroprene sheathed cable  
Overall length: 0.28 inch (7mm)  
Length: 0.20 inch (5m)
- Excitation cable – 3-wire chloroprene sheathed cable  
Overall length: 0.28 inch (7mm)  
Length: 0.20 inch (5m)

**Coating:** phthalic acid resin coating pearl-gray colored

**Weight:** approximately 2.2 lb (1.0 kg)  
(for each size excluding cables)

## ■ Model LF612 converters

### Input signals

**Analog signal** — the voltage signal from detector, proportional to process flow rate (for LF612 separate type converter).

### Digital input DI (opt.)

Signal type: 20 to 30Vdc voltage signal  
Input resistance: 2.7k $\Omega$   
Number of inputs: one point

**DI function** — One of the following functions can be assigned to the optional DI signal.

**Range switching** — Selects either the higher or lower range in the unidirectional or bidirectional 2-range setting.

**Totalizer control** — Starts and stops the built-in totalizer.

**Fixed-value outputs** — Outputs fixed-values for current and pulse outputs.

**Zero adjustment** — Executes zero adjustment (on-stream at zero flow rate).

### Output signals

#### Current output:

4–20mA<sub>dc</sub> (load resistance 0 to 750 $\Omega$ )

**Note:** The current output cannot be used with the PROFIBUS-PA communication.

**Digital outputs** — One point (std.) and one more point is optionally available as follows.

#### Digital output DO1 (std.):

Output type: Transistor open collector  
Number of outputs: One point  
Output capacity: 30V<sub>dc</sub>, 200mA maximum

#### Digital output DO2 (opt.):

Output type:  
Solid-state relay output (non polarity)  
Number of outputs: One point  
Output capacity: 150V<sub>dc</sub>, 150mA maximum  
or 150V<sub>ac</sub> (peak to peak), 100mA maximum

**DO1 and DO2 functions** — One of the following functions can be assigned to DO1 (std.) and/or DO2 (opt.)

#### • Pulse output (available only for DO1, DO2)

Pulse rate: 3.6 to 36,000,000 pulses/hr (DO1)  
3.6 to 360,000 pulses/hr (DO2)  
(Over 3,600,000 pulses/hr, auto-setting)  
Pulse width: 0.5 to 500ms (but less than half of the period for 100% flow rate)

**Note:** The same and simultaneous pulse is not available between DO1 and DO2.)

#### • Multi-range selection outputs (Note 1)

#### • High, High high, Low, and/or Low low alarm outputs (Note 2)

#### • Empty pipe alarm output

#### • Digital Output Active Status (DO1 and DO2) (Note 2)

#### • Preset count output

#### • Converter failure alarm output

**Note 1:** Two outputs (DO1 and DO2) are needed for 4-range switching and forward/reverse 2-range switching.

**Note 2:** Normal Open (default set) or Normal Close is selected for alarm outputs when programming. When power failure occurs, unit will be fault to Normal Open.

**Communications output :**

- **HART (std.)** — Digital signal is superimposed on 4–20mA dc current signal as follows:  
Conforms to HART protocol  
Load resistance: 240 to 750Ω  
Load capacitance: 0.25μF maximum  
Load inductance: 4mH maximum
- **PROFIBUS(opt.)**  
Protocol: PROFIBUS-PA  
Baud rate: 31.25kbps  
Bus voltage: 9-30VDC  
Consumption electric current of bus: less than 16mA  
Manufacture Ident-No.: 093B<sub>HEX</sub>  
Standard Ident-No.: 9740<sub>HEX</sub>  
Slave address: 0-126 (Default address is 126)  
Profile: Profile Ver.3.01 for Process Control Devices  
Function blocks: AI(Flow)×1 , Totalizer×1

**LCD display:**

Full dot-matrix 128×128 dot LCD display (back-light provided)  
The data on the LCD inside the converter can rotate to 90, 180, and 270 degrees by a software, without rotating the indicator itself. (Combined type only)

**Parameter settings** — Parameters can be set as follows:

- **IR Switches:** Three key switches are provided to set configuration parameters.
- **Digital communication:** The AF900 hand-held terminal or PROFIBUS is needed to set parameters.
- **Zero adjustment:** Zero point adjustment can be started by pressing the switch in the converter.
- **Damping:** 0.5 to 60 seconds (selectable in one second increments)

**“Field re-verification” Mag-Prover** – Toshiba’s Zero span calibration tool allows unit to be re-calibrated and verified using an internal software program. (For more information contact Toshiba International Corp.)

**Conditions when power fails:**

Parameter setting values are stored in non-volatile memory and the values will be restored when the power returns to normal condition. The outputs and display will remain as follows when power fails.

- Current output: 0mA dc
- Digital output: OFF
- LCD display: No display
- PROFIBUS: No communication

**Power supply:**

One of the following can be selected:

- 100 to 240Vac, 50/60Hz (std.) (allowable voltage 80 to 264Vac)
- 24Vdc (allowable voltage 18 to 36Vdc)
- 110Vdc (allowable voltage 90 to 130Vdc)

**Surge protection:**

Arresters are installed in the power supply and a current signal output circuit to help protect the meter from lightning and improve personnel safety.

**Case:** Aluminum alloy (equal to IP 67)

**Coating:** Acrylic resin-baked coating, pearl-gray colored

**Cable connection port:****Cable glands** —

Provided as standard, OD of 11 to 13mm  
Material Nylon 66  
G (PF) 1/2 male screws

**Applicable diameter** —

0.433 to 0.512 inch (11 to 13mm)

**Note:** When PROFIBUS option is specified, cable gland size is  $\phi$  6~8mm for signal cable,  $\phi$  11~13mm for power cable

**Vibration resistance:**

No resonance to the following levels of vibration:

- 10 to 150Hz with acceleration of 9.8m/s<sup>2</sup>
- Vibration of 30Hz with 29.4 m/s<sup>2</sup> in 4h in each direction will not cause any defect to unit.

**Note:** Avoid using the flowmeter in an environment with constant vibration.

**Dimensions :**

See Figure 5

**MTBF:**

Converter: 220,000 hours (25 years) at 77 °F (25 °C)  
based on strict military specification  
MIL-HDBK-217F

Detector: 350,000 hours (40 years) at 77 °F (25 °C)  
based on strict military specification  
MIL-HDBK-217F

# Installation

## ■ Dimensions

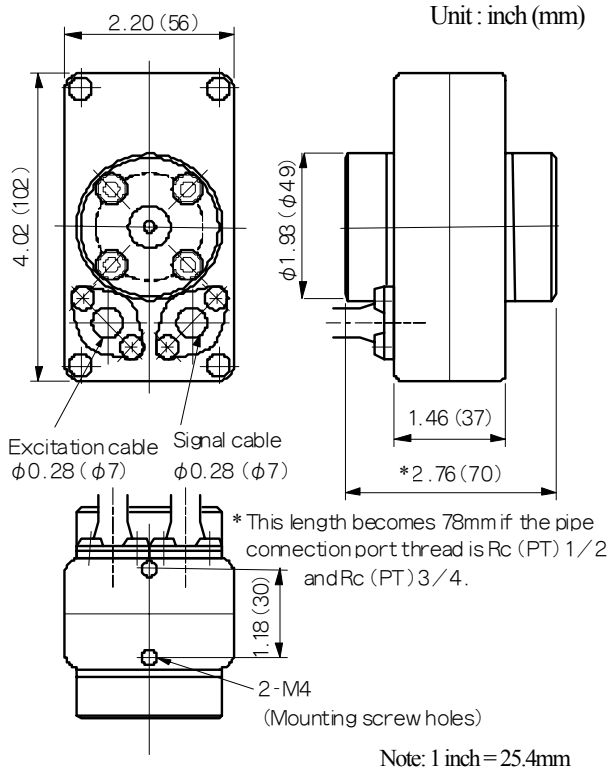
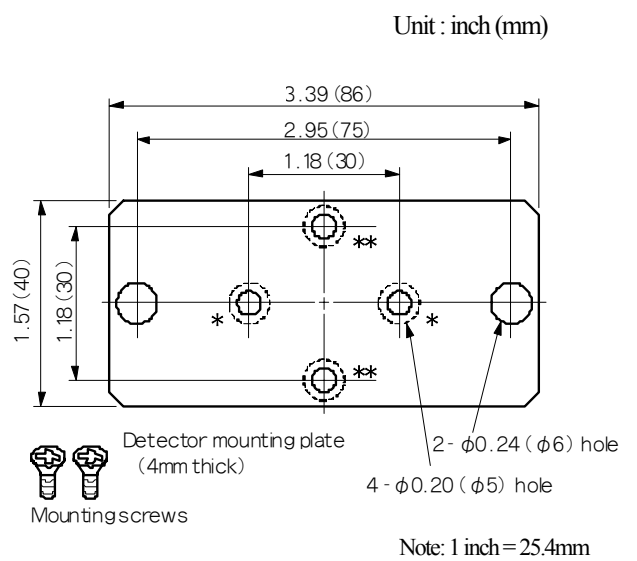

Figure3. LF470 Dimensions



If a mounting plate is needed for the LF470, fix the plate (a) above to the bottom of the LF470. Depending on which pair of screw holes used, the mounting angle changes by 90° .

Figure4. LF470 Mounting Board

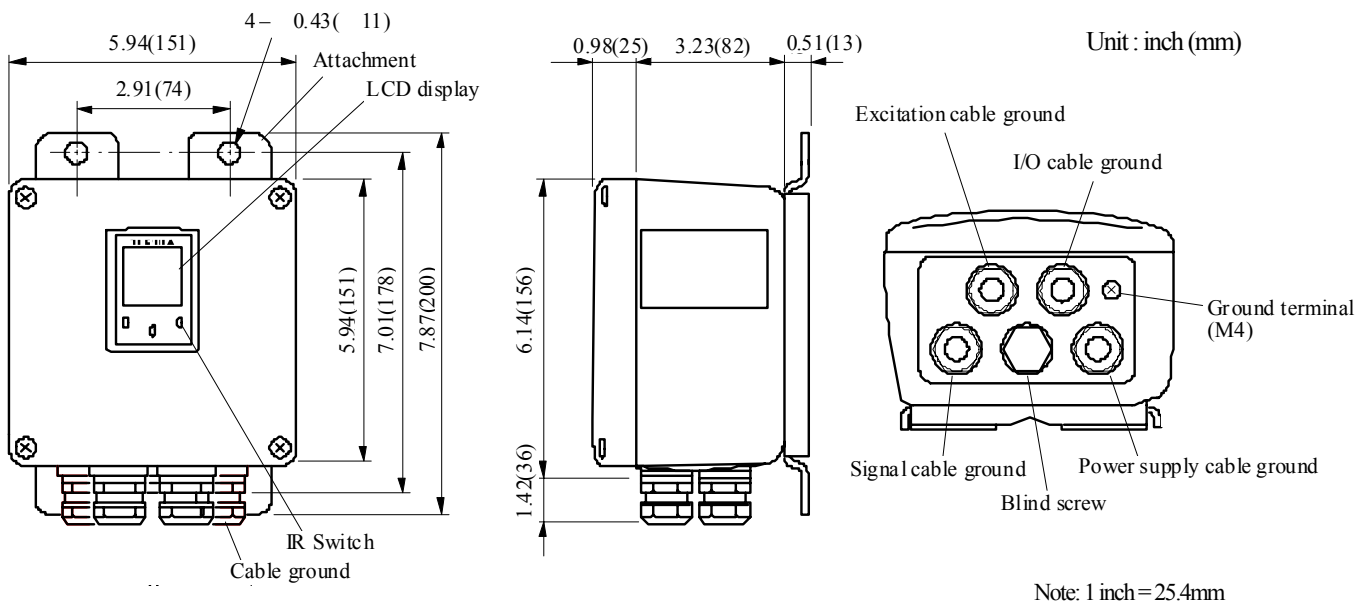

Figure 5. Separate type converter LF612

Separate type LF470/LF612 flowmeter

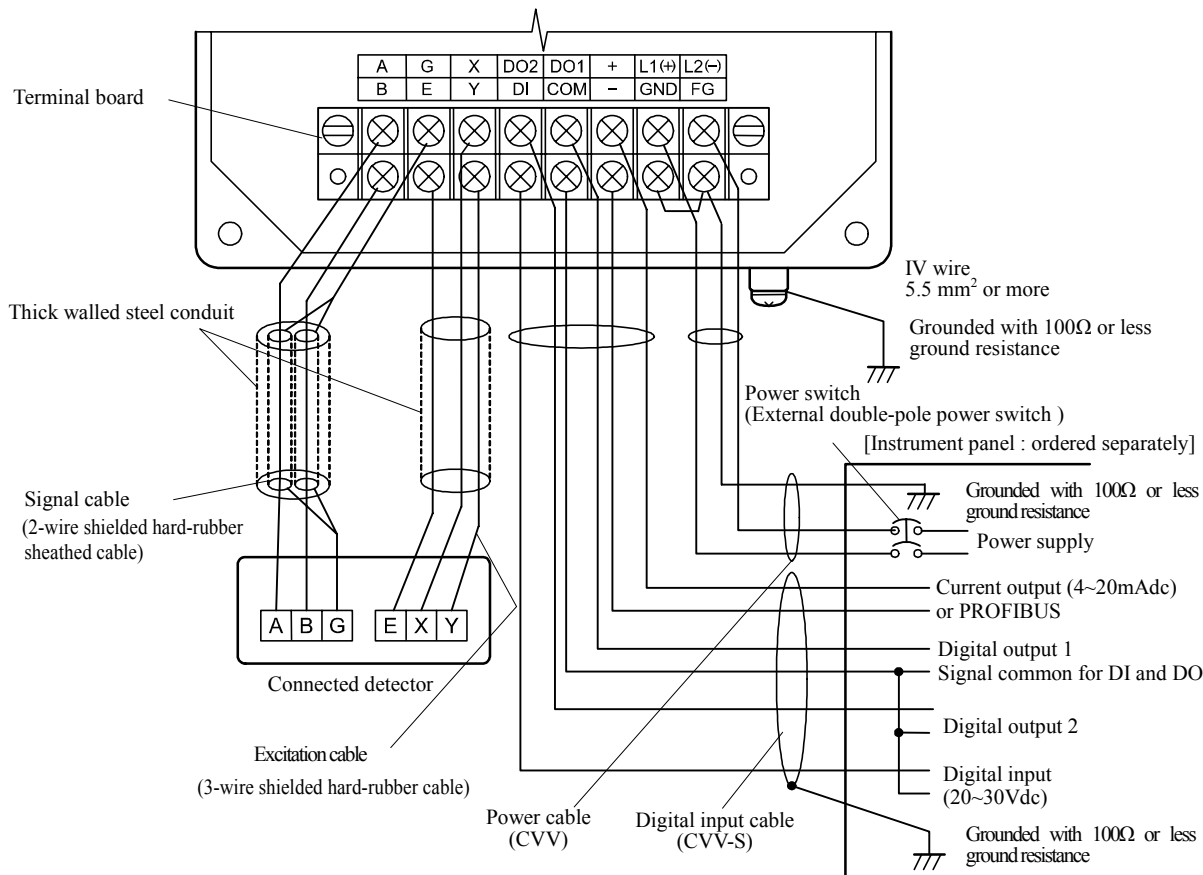

Figure 6. Separate type LF470/LF612 flowmeters wiring Diagram

Table 1. LF612 Converters Signal Table

Symbol	Description	Cable
L1 (+)	Power supply	Power cable (CVV)
L2 (-)		
GND	Ground (for arrester)	
FG	Frame ground	
DI	Digital Input (20~30Vdc)	I/O cable (CVV-S)
DO1	Digital Output 1	
DO2	Digital Output 2	
COM	Signal Common for DI, DO1, DO2	
+	Current Output (4~20mAdc) or PROFIBUS	
-		
X	Excitation Output	Excitation cable
Y		
E		
A	Signal Input	Signal cable
B		
G		

**■ Wiring Precautions**

- (1) Connect the following two cables correctly:
  - 1) signal cable (on the right facing the LF470)
  - 2) excitation cable (on the left facing the LF470)
- (2) Do not bend apply excessive force to these cables.

**■ Piping Precautions**

- (1) Connect the fluid pipe to the pipe connection port using a joint that matches the Rc (PT) female screw. Use seal tapes when connecting the pipe to the port to prevent a fluid leakage. Do not tighten the connection screw too much.
- (2) Design piping so that the detector's pipe is always filled with the fluid to be measured, whether the fluid is flowing or not.
- (3) The fluid to be measured must be held still in the pipe when the LF470 is being adjusted. If the fluid can not be stopped after the LF470 installation, install a bypass pipe in parallel with the LF470 flowmeter.

**■ Meter size**

**To select the meter size:**

See Table 3 to 4 and find meter sizes within the velocity of 0.3 to 32.8 ft/s (0.1 to 10m/s) for a specified full-scale (measuring range high limit) flow. Select one that has its full-scale velocity between 3.0 and 10 ft/s (1 and 3m/s).

**Note:** Make sure the full-scale flow rate used for the final planning stage stays within 32.8 ft/s (10m/s) in terms of flow velocity.

**Table 2. Meter size and Flow Velocity (SI unit)**

Meter size (inch)	Unit:gal/min			
	0.98 ft/s	3 ft/s	10 ft/s	32.8 ft/s
1/10"	0.02334	0.07115	0.2372	0.7781
1/6"	0.05975	0.1821	0.6071	1.992
1/4"	0.1344	0.4098	1.3660	4.482

**Table 3. Meter size and Flow Velocity(US unit)**

Meter size (mm)	Unit:L/min			
	0.3m/s	1m/s	3m/s	10m/s
2.5	0.08835	0.2945	0.884	2.945
4	0.2262	0.7540	2.262	7.540
6	0.5088	1.6967	5.090	16.967

**■ About establishment environment**

Do not store or install the flowmeter:

- Where there is direct sunlight.
- Where excessive vibration or mechanical shock occurs.
- Where high temperature or high humidity conditions exist.
- Where corrosive atmospheres exist.
- Places that can be submerged under water.
- Where there is a sloped floor. To put the flowmeter temporarily on the floor, place it carefully with something, such as a block, to support it so that the flowmeter will not topple over.

In areas like the following, there may be the case that infrared switches do not function correctly. (If these are unavoidable, use an appropriate cover.)

- (1) Where unit (operation panel) is exposed to direct sunlight, reflection of light onto window pane and diffused light reflection.
- (2) Where smoke and steam may occur.
- (3) Where exposed to direct snow, ice or mud.

**Ordering Information**

1. When ordering the LF470 flowmeters, refer to Tables 4 to 5 (Specification Code). An entry must be made for each of the columns in each of these tables.
2. Fluid characteristics:
  - (1) Type of fluid to be measured and its characteristics
  - (2) Fluid temperature
  - (3) Fluid pressure
  - (4) Electrical conductivity of the fluid
3. Measuring range
4. I/O function setting
5. Ordering scope:
 

Flow calibration data: (required or not)
6. Other items
 

Specifications other than standard items

**Consult a Toshiba representative before ordering when choosing materials of the wetted parts such as lining, electrodes, and grounding rings.**

**Table 4. Specification Code ( LF470 Detector )**

Model					Specification Code										Description
1	2	3	4	5	6	7	8	9	10	11	12	13	14		
L	F	4	7	0											LF470 Flowmeter
					2										Meter size 1/10" (2.5 mm )
					4										1/6" (4 mm )
					6										1/4" (6 mm )
						D									Converter ( Separate type ) combined LF612
						E									LF232 (Note 1)
							A								Pipe connection port (adapter)
							B								Rc (PT) 1/4 female screw (standard)
							C								Rc (PT) 1/8 female screw
							D								Rc (PT) 3/4 female screw
							E								Rc (PT) 1/2 female screw
							F								NPT1/4 female screw
							G								NPT3/8 female screw
															NPT1/8 female screw
								A							Pipe connection material
								D							316 stainless steel (standard)
								E							Ti (titanium)
								F							Polyvinyl chloride (shock-resistance)+ Ta (Tantalum) for grounding plate
								H							Polyvinyl chloride (shock-resistance)+ Pt-Ir for grounding plate Hastelloy C (Equivalent)
									C						Packing used between main body and pipe connection adapter
									D						Acid-resistant ceramic
									G						Alkali-resistant ceramic Ammonia-resistance
										A					Mounting
										B					Not provided Provided, 304 stainless steel
											A				Flow and calibration velocity range
											B				1.0 to 32.8 ft/s (standard range calibration) 1.0 to 32.8 ft/s (specified range calibration)
												A			Cable length
												1			5m (cable dia.7mm)
												2			10m (cable dia.7mm)
												3			15m (cable dia.7mm)
												4			20m (cable dia.7mm)
												5			25m (cable dia.7mm)
												B			30m (cable dia.7mm)
															5m or more (extension dia. 12mm+Scotch cast connection)
													A		Coating
													Z		Phthalic acid resin coating pearl-gray colored (standard) Other

**Note 1: Please refer to document number "TIC-LF232" about converter LF232.**

**Table 5. Specification Code for converters**

Model						Specification Code								Contents	LF612 type
1	2	3	4	5	6	7	8	9	10	11	12	13	14		
L	F	6	1											Electromagnetic flowmeter converter	
				2										Separate (Remote) type	●
					A									Purpose Standard	●
						B								Shape Separate type with case	●
							A							Converter mounting fitting None	○
							C							Panel, Accessory for wall mounting (BNP material: SUS304)	●
							E							Accessory for pipe installation (BNP material: SUS304)	○
								1						Digital input/output Digital output points 1 (DO1)	●
								2						Digital output points 2 (DO1+DO2) +Digital input point 1 (DI)	○
									1					Current output and Communication function Current output + HART communication	●
									2					PROFIBUS communication (Current output is not usable)	○
										1				Power supply 100Vac-240Vac, 50/60Hz	●
										2				24Vdc	○
										3				110Vdc	○
											E			Instruction manual English	●

Code explanation: ●: Standard ○: Option

ISO9001 and ISO14001 are certified.

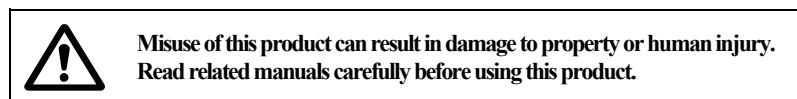

Specifications are subject to change without notice.

Printed in Japan 2008-5 (TDOC)

© TOSHIBA Corporation 2008

All Rights Reserved.

<http://www.toshiba.com/ind/>



## Free Manuals Download Website

<http://myh66.com>

<http://usermanuals.us>

<http://www.somanuals.com>

<http://www.4manuals.cc>

<http://www.manual-lib.com>

<http://www.404manual.com>

<http://www.luxmanual.com>

<http://aubethermostatmanual.com>

Golf course search by state

<http://golfingnear.com>

Email search by domain

<http://emailbydomain.com>

Auto manuals search

<http://auto.somanuals.com>

TV manuals search

<http://tv.somanuals.com>