

TOSHIBA

**UNINTERRUPTIBLE POWER SYSTEM
THREE-PHASE 15/25/30/50 kVA UPS**

4200FA CT/XT User's Manual

Document Number: 53878-006
Date: September 2007



TOSHIBA

4200FA CT/XT

THREE-PHASE 15/25/30/50 kVA

UNINTERRUPTIBLE POWER SYSTEM

CT-Internal Batteries

XT- External Batteries or External Transformer

**USER'S MANUAL
FOR MODELS**

C42F3F150X#MBN

C42F3F150F#MBN

C42#3#150##MXN

C42F3F250X#MBN

C42F3F250F#MBN

C42#3#250##MXN

T42F3F300X#MBN

T42F3F300F#MBN

T42#3#300##MXN

T42F3F500X#MBN

T42F3F500F#MBN

T42#3#500##MXN

TOSHIBA INTERNATIONAL CORPORATION

INDUSTRIAL DIVISION

13131 West Little York Road
Houston, TX 77041-9990

IMPORTANT NOTICE

The Instructions contained in this manual are not intended to cover all of the details or variations in equipment or to provide for every possible contingency to be met in connection with installation, operation, or maintenance. Should further information be required or should particular problems arise which are not covered sufficiently the matter should be referred to the local TOSHIBA sales office.

The contents of this instruction manual shall not become a part of or modify any prior or existing equipment, commitment, or relationship. The sales contract contains the entire obligation of TOSHIBA INTERNATIONAL CORPORATION. The warranty contained in the contract between the parties is the sole warranty of TOSHIBA, and any statements contained herein do not create new warranties or modify the existing warranty.

Any Electrical or mechanical modifications to this equipment without prior written consent of the TOSHIBA will void all warranties and may void UL/CUL listing. Unauthorized modifications may also result in equipment damage, personal injury, or loss of life.

UNINTERRUPTIBLE POWER SYSTEM

If additional information or technical assistance is required call TOSHIBA Customer Support Center toll free at 1- 877-876-8773, or write to: Toshiba International Corporation, 13131 West Little York Road, Houston, TX 77041-9990 Attn: UPS Product Manager.

Please complete the following information for your records. Unless otherwise specified on the warranty card, the warranty period for the UPS or UPS part is 36 months from the shipment date (see bill of lading).

Unless otherwise specified on the warranty card, the warranty period for a UPS battery is 24 months from the shipment date (see bill of lading).

Keep this manual with the UPS equipment.

Job Number: _____

Model Number: _____

Serial Number: _____

Application: _____

Shipping Date: _____

Date of Installation: _____

Inspected By: _____

TABLE OF CONTENTS

| | |
|---------------------------------------------------------------------------------------------|-----------|
| IMPORTANT NOTICE | 2 |
| TABLE OF CONTENTS | 3 |
| Purpose and Scope of Manual | 5 |
| Contacting TOSHIBA Customer Support Center | 5 |
| GENERAL SAFETY INSTRUCTIONS | 6 |
| EQUIPMENT WARNING LABELS | 7 |
| IMPORTANT SAFETY INSTRUCTIONS | 10 |
| 1.0 Product Description | 14 |
| 1.1 Theory of Operation..... | 14 |
| 1.2 Application and Use..... | 14 |
| 1.3 Power Backup..... | 14 |
| 1.4 Power Conditioning..... | 14 |
| 2.0 Unpacking/Inspection/Storage/Disposal | 15 |
| 2.1 Unpacking the new UPS equipment 15/25/30 kVA:..... | 15 |
| 2.2 Unpacking the new UPS equipment 50 kVA:..... | 16 |
| 2.3 Inspection of the new UPS equipment..... | 16 |
| 2.3 Inspection of the new UPS equipment..... | 17 |
| 2.4 Storage of UPS equipment..... | 17 |
| 2.5 Disposal..... | 17 |
| 3.0 Installation Precautions | 18 |
| 3.1 Equipment Placement..... | 18 |
| 3.2 System Preparation (Pre-Power)..... | 19 |
| 3.3 Operating Precautions..... | 19 |
| 4.0 UPS Connections | 20 |
| 4.1 Power Connections..... | 20 |
| 4.1.1 Power Connections 15/25/30 kVA with Internal Batteries..... | 20 |
| 4.1.2 Power Connections 15/25/30 kVA with Internal Transformer..... | 21 |
| 4.1.3 Recommended Wire Size and Torque Requirements..... | 22 |
| 4.1.4 Power Connection Cable Routing and Conduit Placement 15/25/30 kVA..... | 23 |
| 4.2 Control Circuit and External Battery Interface Connections 15/25/30 kVA..... | 24 |
| 4.2.1 Recommended Wire Size and Torque Requirements..... | 24 |
| 4.3 Power Connections 50 kVA..... | 25 |
| 4.3.1 Recommended Wire Size and Torque Requirements For UPS Input and Output Terminals..... | 26 |
| 4.3.2 Power Connection Cable Routing and Conduit Placement 50 kVA..... | 27 |
| 4.4 Control Circuit and External Interface Connections 50 kVA..... | 28 |
| 4.4.1 Recommended Wire Size and Torque Requirements..... | 28 |
| 4.5 Communication Interface..... | 29 |
| 4.5.1 Remote Contact..... | 29 |
| 4.5.2 RS-232C..... | 30 |
| 4.5.3 UPS Shutdown (via RS-232C)..... | 30 |
| 5.0 Specifications | 31 |
| 5.1 4200FA 15 / 25 kVA @ 208 VAC Input/ 208 VAC Output w/Internal Batteries..... | 31 |
| 5.2 4200FA 15/25 kVA w/Internal Transformer..... | 32 |
| 5.3 4200FA 30 kVA @ 208 VAC Input/ 208 VAC Output w/Internal Batteries..... | 33 |
| 5.4 4200FA 30 kVA w/Internal Transformer..... | 34 |
| 5.5 4200FA 50kVA @ 208 VAC Input/ 208 VAC Output w/Internal Batteries..... | 35 |
| 5.6 4200FA 50kVA w/Internal Transformer..... | 36 |

| | | |
|------------|-----------------------------------------------------------------|-----------|
| 6.0 | Operating the UPS | 37 |
| 6.1 | AC Input Mode (Normal Operation)..... | 37 |
| 6.2 | Bypass Mode..... | 38 |
| 6.4 | Battery Backup Mode | 39 |
| 6.5 | Battery Backup Time and Discharge Process | 40 |
| 6.6 | Battery Low Voltage Tolerances | 40 |
| 6.7 | Battery Recharging..... | 41 |
| 6.8 | Front Panel Layout (All Units) | 42 |
| 6.9 | EPO (Emergency Power Off) Function | 42 |
| 6.10 | Audible Alarm Functions | 43 |
| 6.11 | LED (Light Emitting Diode) Functions | 43 |
| 6.11.1 | LED (Light Emitting Diode) System Status | 44 |
| 6.12 | LCD (Liquid Crystal Display) Functions | 44 |
| 6.12.1 | Line-1 System Messages..... | 44 |
| 6.12.2 | Line-2 System Fault Messages..... | 45 |
| 6.12.3 | Line-3 System Messages..... | 45 |
| 6.12.4 | Line-4 System Messages..... | 45 |
| 6.13 | Initial Battery Charge..... | 46 |
| 6.14 | Start-up Procedure | 47 |
| 6.15 | Shutdown Procedure..... | 48 |
| 6.16 | Maintenance Bypass Procedure | 48 |
| 6.17 | Keypad Overview | 50 |
| 6.18 | Key Functions..... | 51 |
| 6.18.1 | MONI | 51 |
| 6.18.2 | IN..... | 51 |
| 6.18.3 | OUT..... | 51 |
| 6.18.4 | BATT Key | 52 |
| 6.18.5 | MENU, F1, ENTER, UP, & DOWN Keys | 52 |
| 6.18.6 | BATT TEST Key..... | 52 |
| 6.18.7 | BUZZ STOP Key..... | 53 |
| 6.18.8 | RESET Key | 53 |
| 6.19 | Menu Data Screens | 54 |
| 6.19.1 | Settings for Calendar and Clock | 54 |
| 6.19.2 | Adjusting the Buzzer Volume | 54 |
| 6.19.3 | Settings for Display Duration..... | 54 |
| 6.19.4 | Run Switch Select | 55 |
| 6.19.5 | Serial Com Station Address | 55 |
| 6.19.6 | Output Voltage Adjustment | 56 |
| 6.19.7 | Charge Mode Select | 56 |
| 6.19.8 | Reset to Default Settings | 57 |
| 6.20 | Overload Operation..... | 57 |
| 6.21 | Backup History and Fault History..... | 58 |
| 7.0 | UPS Protection System | 60 |
| 7.1 | System Protection Features..... | 60 |
| 7.2 | System Protection Functions | 60 |
| 8.0 | Start-up/Scheduled Maintenance/Part Replacement..... | 61 |
| 8.1 | Start-up..... | 61 |
| 8.2 | Preventive Maintenance..... | 61 |
| 8.3 | Parts Replacement..... | 62 |
| 9.0 | External Dimensions / Shipping Dimensions / Weights..... | 63 |
| 9.1 | External Dimensions 15/25/30 kVA | 63 |
| 9.2 | External Dimensions 50kVA..... | 64 |
| 9.3 | Shipping Dimensions and Weights | 65 |

Purpose and Scope of Manual

This manual provides information on how to safely install, operate, and maintain your TOSHIBA power electronics product. This manual includes a section on General Safety Instructions that describes the warning labels and symbols that are used throughout the manual. Read the manual completely before installing, operating, or performing maintenance on this equipment.

This manual and the accompanying drawings should be considered a permanent part of the equipment and should be readily available for reference and review. Dimensions shown in the manual are in metric and/or the English equivalent.

TOSHIBA reserves the right, without prior notice, to update information, make product changes, or to discontinue any product or service identified in this publication.

TOSHIBA is a registered trademark of TOSHIBA INTERNATIONAL CORPORATION. All other product or trade references appearing in this manual are registered trademarks of their respective owners.

TOSHIBA shall not be liable for technical or editorial omissions or mistakes in this manual. Nor shall it be liable for incidental or consequential damages resulting from the use of information contained in this manual.

This manual is copyrighted. No part of this manual may be photocopied or reproduced in any form without the prior written consent of TOSHIBA INTERNATIONAL CORPORATION.

© Copyright 2007 TOSHIBA INTERNATIONAL CORPORATION.

All rights reserved.

Printed in the U.S.A.

Contacting TOSHIBA Customer Support Center

The TOSHIBA Customer Support Center can be contacted to obtain help in resolving any **Uninterruptible Power System** problem that you may experience or to provide application information.

The center is open from 8 a.m. to 5 p.m. (CST), Monday through Friday. The Support Center's toll free number in USA is (877) 867-8773.

You may contact TOSHIBA by writing to:

TOSHIBA INTERNATIONAL CORPORATION.
INDUSTRIAL DIVISION
13131 West Little York Rd.
Houston, TX 77041-9990
Attn: UPS Product Manager

GENERAL SAFETY INSTRUCTIONS

DO NOT attempt to install, operate, maintain or dispose of this equipment until you have read and understood all of the product safety information and directions that are contained in this manual.

Safety Alert Symbol



The **Safety Alert Symbol** indicates that a potential personal injury hazard exists. The symbol is comprised of an equilateral triangle enclosing an exclamation mark.

Signal Words

Listed below are the signal words that are used throughout this manual followed by their descriptions and associated symbols. When the words **DANGER**, **WARNING** and **ATTENTION** are used in this manual they will be followed by important safety information that must be carefully adhered to.

Warnings in this manual may appear in any of the following ways:

- 1) *Danger warning* – The danger symbol is an exclamation mark enclosed in a triangle, which precedes the word “DANGER.” The Danger warning symbol is used to indicate situations, locations, and conditions that exist and will cause serious injury or death.



DANGER

- 2) *Caution warning* – The caution symbol is an exclamation mark enclosed in a triangle, which precedes the word “CAUTION.” The Caution warning symbol is used to indicate situations and conditions that can cause operator injury and/or equipment damage.



CAUTION

- 3) *Attention warning* – The attention warning symbol is an exclamation mark enclosed in a triangle which precedes the word “ATTENTION.” The Attention warning symbol is used to indicate situations and conditions that can cause operator injury and/or equipment damage.



ATTENTION

Other warning symbols may appear along with the *Danger* and *Caution* symbol and are used to specify special hazards. These warnings describe particular areas where special care and/or procedures are required in order to prevent serious injury and possible death.

- 1) *Electrical warning* – The electrical warning symbol is a lightning bolt enclosed in a triangle. The Electrical warning symbol is used to indicate high voltage locations and conditions that may cause serious injury or death if the proper precautions are not observed.



- 2) *Explosion warning* – The explosion warning symbol is an explosion image enclosed in a triangle. The Explosion warning symbol is used to indicate locations and conditions where molten exploding parts that may cause serious injury or death if the proper precautions are not observed.





EQUIPMENT WARNING LABELS



DO NOT attempt to install, operate, maintain or dispose of this equipment until you have read and understood all of the product warnings and user directions that are contained in this instruction manual.

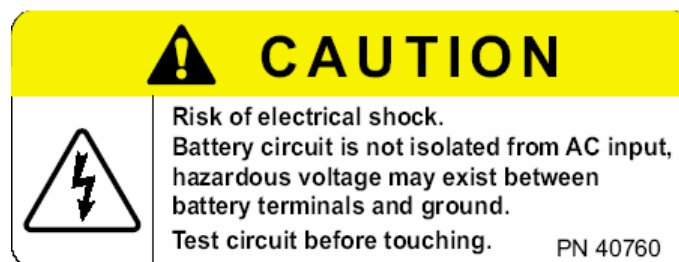
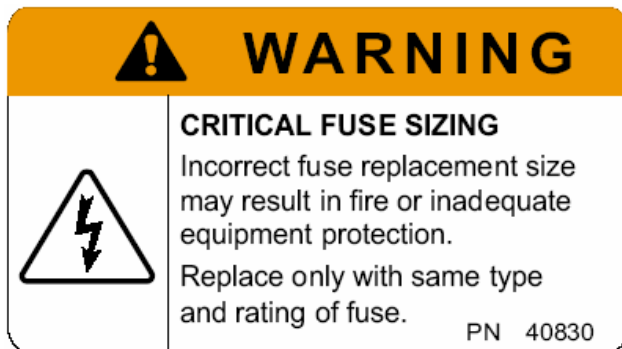
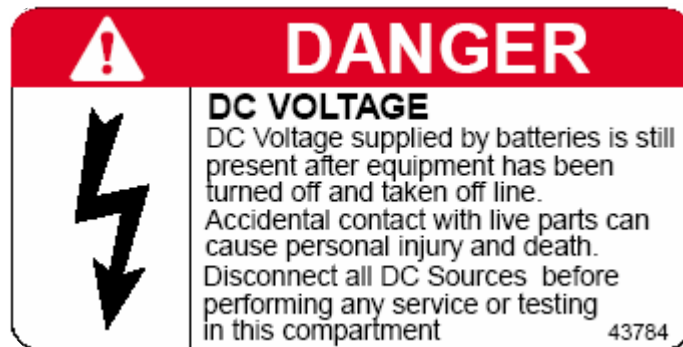

Shown below are examples of warning labels that may be found attached to the equipment. **DO NOT** remove or cover any of the labels. If the labels are damaged or if additional labels are required, contact your TOSHIBA representative for additional labels.

The following are examples of the warning labels that may be found on the equipment. The labels are there to provide useful information or to indicate an imminently hazardous situation that may result in serious injury, severe property and equipment damage, or death if the instructions are not followed.



|  DANGER | |
|-------------------------------------------------------------------------------------------------|--------------------------------------------------------------------------------------------------------------------------------------------------------------------------------------------------------------------------------------------------------------------------------------------------------------------|
|  | RISK OF ELECTRIC SHOCK Capacitors stay charged after power has been shut off. Accidental contact with live parts can cause personal injury and death. Turn off and lock out all power sources. Wait at least five (5) minutes for power to dissipate then check voltage before servicing. 39561 |

|  DANGER | |
|-----------------------------------------------------------------------------------------------------------------------------------------------------------------------------------------------------------------------------------------------------------------------------------------------------------------------------------------------------------------------------------------------------------------------------------------------------------------------------------------------------------------------------------------------------------------------------------------------------------------------------------------------------------------------------------------------------------------------------------------------------------------------------------------------------------------------------------------------------------------------------------------------------------------------------------------------------------------------------------------------------------------------------------------------------------------------------------------------------------------------------------------------------------------------------------------------------------------------|--------------------------------------------------------------------------------------------------------------------------------------------------------------------------------------------------------------------------------------------|
|  | HAZARDOUS VOLTAGES Hazardous voltages are used in the operation of this equipment and could cause severe personal injury or loss of life. The following precautions should be observed to reduce the risk of injury or death. |
| <p>Only qualified technicians familiar with this equipment and the information supplied with it should be permitted to install and operate this equipment.</p> <p>Installation of electrical equipment must be done in accordance with National Electrical Code and any other state or local codes. Proper grounding and conductor sizing must be installed for safe operation.</p> <p>During operation, keep all covers in place and cabinet doors shut.</p> <p>When performing visual inspections and maintenance, if possible, be sure the UPS is turned off and the incoming AC feed is turned off and locked out.</p> <p>The UPS and Battery Cabinet will have hazardous voltages present even after the AC feed is turned off.</p> <p>If it is necessary to make measurements with the power on, do not touch any electrical connection points. Remove all jewelry from wrists and fingers. Make sure test equipment is in good, safe operating condition.</p> <p>While servicing, stand on some type of insulation, and be sure not to be grounded.</p> <p>Follow the safety instructions given in the equipment manual carefully and observe all danger, warning and caution notices.</p> <p>40308</p> | |

|  CAUTION | |
|----------------------------------------------------------------------------------------------------|--------------------------------------------------------------------------------------------------------------------------------------------------------|
|  | <p>Heat sink not grounded.</p> <p>Risk of electrical shock.</p> <p>Disconnect UPS and electrically test heat sink before touching.</p> <p>PN 40831</p> |



CAUTION - Risk of electric shock

DO NOT REMOVE COVER. NO USER SERVICEABLE PARTS INSIDE. REFER SERVICING TO QUALIFIED SERVICE PERSONNEL. HAZARDOUS LIVE PARTS INSIDE THIS UPS ARE ENERGIZED FROM THE BATTERY SUPPLY EVEN WHEN THE INPUT AC POWER IS DISCONNECTED.

CAPACITORS STORE HAZARDOUS ENERGY. DO NOT REMOVE COVER UNTIL 5 MINUTES AFTER DISCONNECTING ALL SOURCES OF SUPPLY.

TO REDUCE THE RISK OF FIRE OR ELECTRIC SHOCK, INSTALL IN A TEMPERATURE AND HUMIDITY CONTROLLED INDOOR AREA FREE OF CONDUCTIVE CONTAMINANTS.



ATTENTION

EN CAS D'UTILISATION EN ATMOSPHERE CONTROLEE. CONSULTER LA NOTICE TECHNIQUE.

BATTERY BACK-UP TIME, WHICH WAS FACTORY-SET AT A PREDETERMINED LEVEL, DECREASES GRADUALLY BETWEEN SERVICE PERIODS. THE BATTERIES SHOULD BE REPLACED EVERY THREE YEARS AFTER THE LAST SERVICING, THE DATE OF WHICH IS WRITTEN ON THE ID PLATE LOCATED ON THE REAR SIDE OF THE UPS UNIT, OR IN THE BOX BELOW.

DATE OF LAST BATTERY CHARGE:

PN 41750

NOTE: This Label for Battery Units Only

IMPORTANT SAFETY INSTRUCTIONS

SAVE THESE INSTRUCTIONS

This manual contains important instructions that should be followed during the installation, maintenance, and operation of the UPS and its batteries to assure safe and proper operation

1. Turn off, lockout, and tagout all power sources before connecting the power wiring to the equipment or when performing maintenance.
2. Hardwire type UPS units are not equipped with an over-current protection device, nor do they have an output disconnect for the ac output. Therefore, a user-installed circuit breaker should be provided between the UPS output and the load input.
3. Battery servicing should be performed by a qualified TOSHIBA Representative only.
4. Unauthorized personnel should not service batteries.
5. Contact your nearest TOSHIBA authorized service center for battery replacement.

Qualified Personnel ONLY!

Qualified Personnel is one that has the skills and knowledge relating to the construction, installation, operation, and maintenance of the electrical equipment and has received safety training on the hazards involved (Refer to the latest edition of NFPA 70E for additional safety requirements).

Qualified Personnel shall:

1. Have read the entire operation manual.
2. Be trained and authorized to safely energize, de-energize, ground, lockout and tag circuits and equipment, and clear faults in accordance with established safety practices.
3. Be trained in the proper care and use of protective equipment such as safety shoes, rubber gloves, hard hats, safety glasses, face shields, flash clothing, etc., in accordance with established safety practices.
4. Be trained in rendering first aid.
5. Be knowledgeable of batteries and the required handling and maintenance precautions.

For further information on workplace safety visit www.osha.gov.

Refer to the Battery System Manual for details on operating and maintaining the battery units for each system.

UPS System's output is not equipped with an over-current protection device, or an output disconnect for the AC output; therefore, a circuit breaker should be provided, by the user, between the UPS output and the critical load input. This minimum current rating for the device should be rated as follows:

| Rated Output | 15 kVA Rating | 25 kVA Rating | 30 kVA Rating | 50 kVA Rating |
|--------------|------------------|------------------|------------------|------------------|
| 208/120 VAC | 240 V, 60 A | 240 V, 90 A | 240 V, 110 A | 240 V, 175 A |
| 220/127 VAC | 240 V, 50 A | 240 V, 90 A | 240 V, 110 A | 240 V, 175 A |
| 240 VAC | 240 V, 50 A | 240 V, 80 A | 240 V, 90 A | 240 V, 175 A |
| 380/220 VAC | 480 V, 30 A | 480 V, 50 A | 480 V, 60 A | 480 V, 100 A |
| 480/277 VAC | 480 V, 25 A | 480 V, 40 A | 480 V, 50 A | 480 V, 80 A |
| 600 VAC | 600 V, 20 A | 600 V, 35 A | 600 V, 40 A | 600 V, 70 A |

TOSHIBA

The maximum ambient temperature in which the Uninterruptible Power System (UPS) should be operated is 104 °F (40 °C) without batteries, and 89 °F (32 °C) if the battery cabinet is subject to the same ambient temperature as the UPS. The nominal battery voltage for all internal battery models is 288 VDC. The nominal battery voltage for all external battery models is 288 VDC.

An Authorized TOSHIBA Representative who is knowledgeable of batteries and the required precautions should perform service on the batteries. Keep unauthorized personnel away from batteries. Refer to the Battery System Manual, when scheduling maintenance or battery replacement.

Refer to the Battery System Manual when scheduling battery maintenance or battery replacement.



DANGER

Misuse of this equipment could result in injury and equipment damage. In no event will TOSHIBA be responsible or liable for direct, indirect, or consequential damage or injury that may result from the use of this equipment.



CAUTION



Do not dispose of the batteries in a fire. The batteries may explode.



CAUTION

Do not open or mutilate the batteries. Released electrolyte is toxic and harmful to the eyes and skin.



CAUTION

This unit contains sealed lead acid batteries. An annual preventative maintenance should be performed by an authorized technician. Failure to do so could result in batteries exploding and emitting gasses, and or flame.



CAUTION

Do not open or mutilate the batteries. Released electrolyte is toxic and harmful to the eyes and skin.



WARNING

Failure to replace a battery before it becomes exhausted may cause the case to crack, possibly releasing electrolytes from inside the battery, and resulting in secondary faults such as odor, smoke, and fire.



WARNING

Only personnel knowledgeable of batteries and the required precautions should perform installation and servicing of batteries. Keep Unauthorized personnel away from the batteries.



WARNING

A qualified service technician must do proper maintenance to the battery system of this unit. This is essential for the safety and reliability of your UPS system. Refer to service manual.



DANGER

A battery can present a risk of electrical shock and high short circuit current.

The following precautions should be observed when working with batteries.

- 1) Verify that the "UPS" is off and that the Input Circuit Breaker is in the off position.
- 2) Remove watches, rings, jewelry, or other metal objects.
- 3) Use tools with insulated handles to prevent accidental shorts.
- 4) Wear rubber gloves and boots.
- 5) Do not lay tools or metal parts on top of batteries.
- 6) Determine if the battery is grounded. If grounded, remove source of the ground.
Contact with any part of a grounded battery can result in an electrical shock.
Electrical shock will be reduced if grounds are removed during installation and maintenance.
- 7) Verify circuit polarities prior to making connections.
- 8) Disconnect charging source and load prior to connecting or disconnecting terminals.
- 9) VRLA batteries contain an explosive mixture of hydrogen gas. Do not smoke; create a flame or a spark in the immediate area of the batteries. This includes static electricity.
- 10) Do not attempt to open the batteries in order to add water or sample the specific gravity of the electrolyte. The batteries are valve regulated lead acid type and such servicing is not possible without damaging the battery.
- 11) Use proper lifting means when moving batteries and wear all appropriate safety clothing and equipment.
- 12) **Dispose of lead acid batteries through proper channels in accordance with Local, State and Federal EPA Regulations.**

To be performed by **Qualified Personnel** only.

- 1) Verify that the UPS is off and that the power cord is disconnected from the power source.
- 2) Remove watches, ring, jewelry, or other metal objects.
- 3) Use tools with insulated handles to prevent inadvertent shorts.
- 4) Wear rubber gloves and boots.
- 5) Do not place tools or any metal parts on top of batteries.
- 6) Determine if the battery is inadvertently grounded. If inadvertently grounded, remove source of ground.

Contact with any part of a grounded battery can result in electrical shock.

The likelihood of shock will be reduced if such grounds are removed prior to installation or maintenance.

INSTRUCTIONS IMPORTANTES CONCERNANT LA SÉCURITÉ

CONSERVER CES INSTRUCTIONS

Cette notice contient des instructions importantes concernant la sécurité



ATTENTION

Un battery puet présenter un risque de choc électrique, de brûlure par transfert d' énergie.



ATTENTION

L'élimination des batteries est règlementée. Consulter les codes locaux à cet effet

1.0 Product Description

1.1 Theory of Operation

An Uninterruptible Power Supply (UPS) is a system that is installed between the commercial power and the critical load. The UPS provides steady AC output power during commercial power fluctuations and interruptions.

During "Normal Operation" the UPS utilizes commercial AC power and removes high voltage spikes and transients caused by switching and faults on the utility. The result of this process is maximum power conditioning and regulation.

If the AC power supplied to the UPS drops below a specified voltage level, the unit's batteries automatically begin supplying power instead of receiving it. This insures that the loads connected to the UPS continue to receive power without interruption. This power is provided for a long enough time so that the load can be shut down in an orderly fashion. This prevents loss of data and possible damage to both hardware and software.

When the AC input power becomes available again, the operation returns to normal and the batteries begin to recharge for the next power interruption.

1.2 Application and Use

The TOSHIBA 4200FA On-Line, Uninterruptible Power Systems (UPS) provide continuous computer grade isolated AC power in a compact, efficient, high performance unit. The UPS assures safe, reliable operation of critical office equipment, ranging from personal computers to mini-computers to local area networks (LAN). All units feature an audible alarm that sounds if the battery voltage drops below the standard during use. This is an additional aid to help in retaining valuable data and equipment. All units are capable of interfacing to a computer network.

1.3 Power Backup

During an electrical power failure the UPS batteries automatically supply DC power to the inverter that supports the load equipment, without interruption. For example, when used to support a computer, the UPS's back up assures additional time to complete your activity, store data and initiate an orderly shutdown after a power failure occurs.

1.4 Power Conditioning

While commercial power is present, the UPS supplies conditioned power to the load while maintaining its batteries in a charged condition. The UPS protects the connected load against the normal, everyday problems associated with heavy use of raw commercial power, including power sags, surges, signal interference, and spikes. In addition, the models with transformers provide total isolation to reduce the common and normal mode noises. This adds further protection to keep power-line problems from reaching your load, where it can cause equipment to operate erratically, or damage hardware and software.

2.0 Unpacking/Inspection/Storage/Disposal

2.1 Unpacking the new UPS equipment 15/25/30 kVA:

Upon receipt of the UPS, a careful inspection for shipping damage should be made. Units shipped within North America are shrink-wrapped; those outside North America are crated.

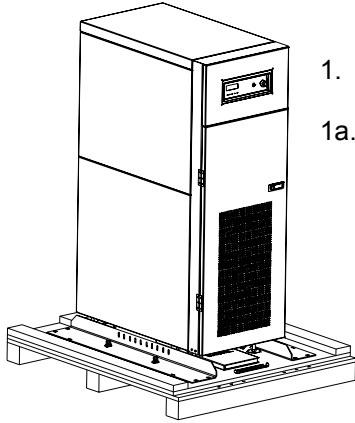

1. Remove packing material.

1a. For international units, remove the screws that attach the shipping crate to the pallet. Remove the crate and foam packing material.

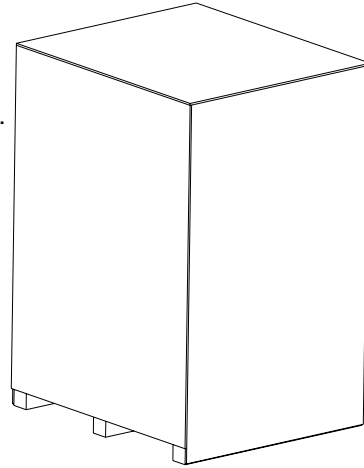

2. Unbolt the rails from both the unit and the shipping pallet. Place the rails on the front of the pallet. Use the four 1/2 x 3" bolts to secure the rails to the shipping pallet. Attach the rails as shown in the front to the front of the pallet.

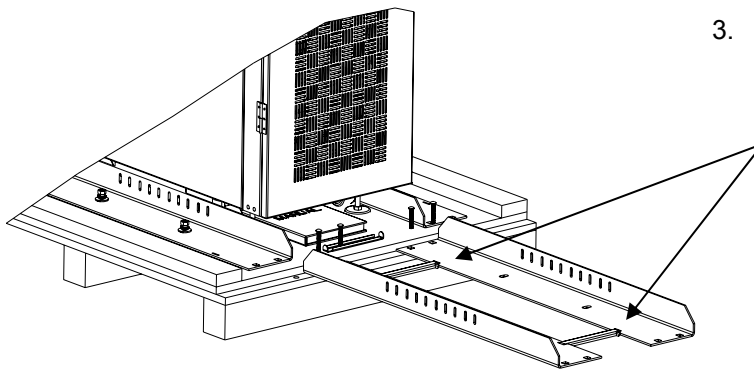
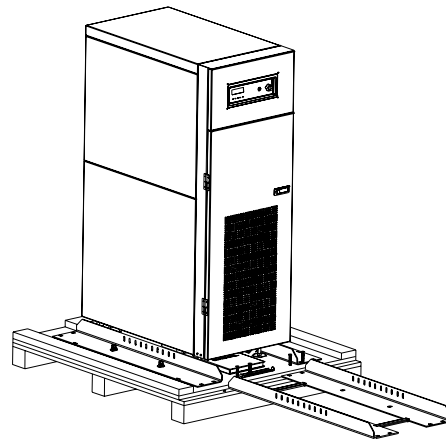

3. Place the tie brackets in the slots at the lower end of the ramps. SLOWLY roll the unit down the ramp.



DANGER

TOP HEAVY EQUIPMENT. IMPROPER LIFTING CAN RESULT IN INJURY OR DEATH. LIFT AND MOVE CAREFULLY AND ONLY WITH ADEQUATE EQUIPMENT AND TRAINED PERSONNEL. THIS EQUIPMENT WILL TIP OVER EASILY UNTIL FIXED IN PLACE.

2.2 Unpacking the new UPS equipment 50 kVA:

Upon receipt of the UPS, a careful inspection for shipping damage should be made. Units shipped within North America are shrink-wrapped; those outside North America are crated.

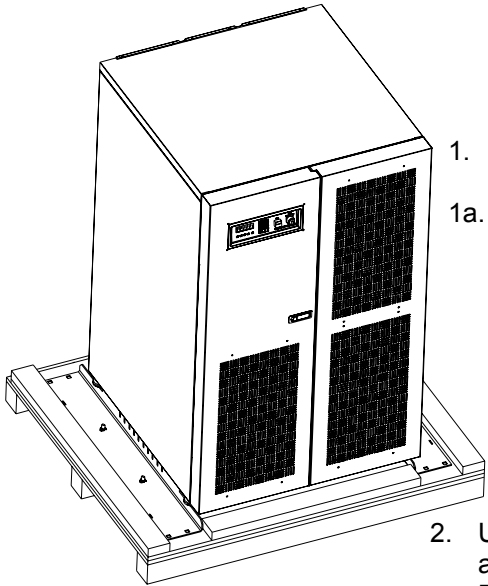

1. Remove packing material.
- 1a. For international units, remove the screws that attach the shipping crate to the pallet. Remove the crate and foam packing material.

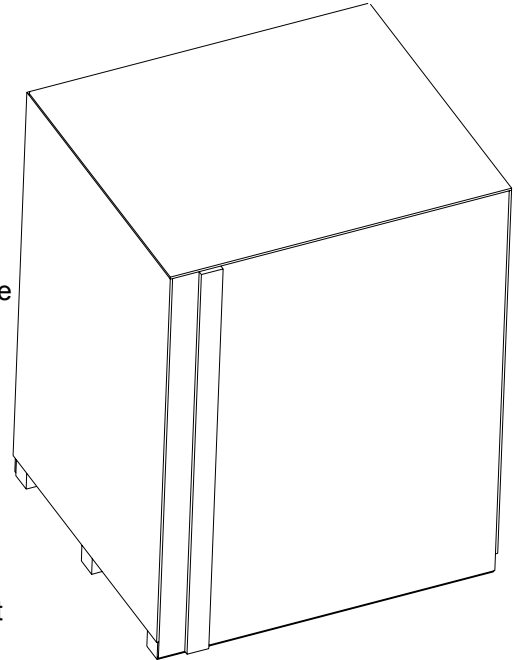

2. Unbolt the rails from both the unit and the shipping pallet. Place the rails on the front of the pallet. Use the four 1/2 x 3" bolts to secure the rails to the shipping pallet. Attach the rails as shown in the front to the front of the pallet.

3. Place the tie brackets in the slots at the lower end of the ramps. SLOWLY roll the unit down the ramp.

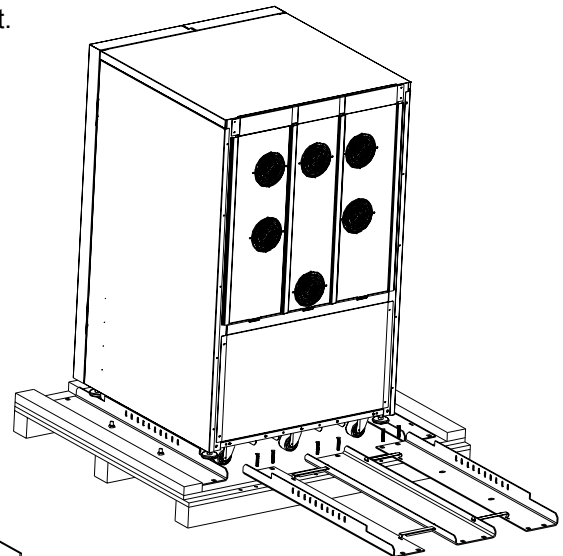
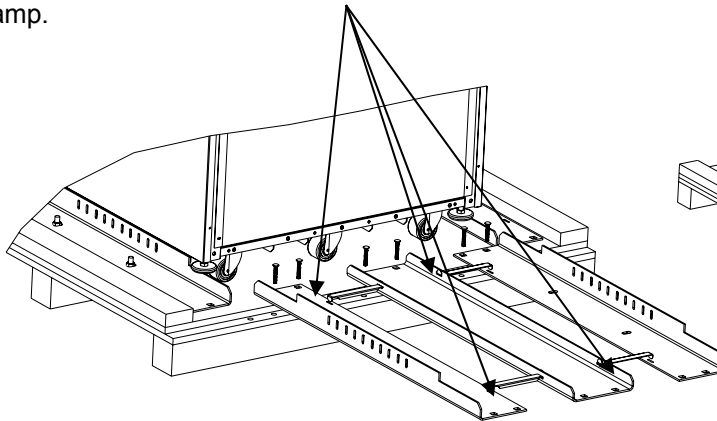

DANGER

TOP HEAVY EQUIPMENT. IMPROPER LIFTING CAN RESULT IN INJURY OR DEATH. LIFT AND MOVE CAREFULLY AND ONLY WITH ADEQUATE EQUIPMENT AND TRAINED PERSONNEL. THIS EQUIPMENT WILL TIP OVER EASILY UNTIL FIXED IN PLACE.

2.3 Inspection of the new UPS equipment

After Unpacking:

- 1) Check the unit for loose, broken, bent or other damaged parts. If damage has occurred during shipment, keep all packing materials for return to the shipping agent. The equipment warranty will not apply to units that are damaged during shipment.
- 2) Check to see that the rated capacity and the model number specified on the nameplate conform to the order specifications.

2.4 Storage of UPS equipment

If the UPS equipment is to be subject to long or short-term storage, the following guidelines should be used.

Avoid:

- 1) Storage in sites subject to extreme changes in temperature or high humidity.
- 2) Storage in sites subject to exposure of high levels of dust or metal particles.
- 3) Storage on inclined floor surfaces or in sites subject to excessive vibration.

Before storing:

- 1) Charge the system's batteries.
- 2) Perform a complete system shutdown as described in section 6.15 of this manual.

Storing:

- 1) Store within a temperature range of - 4 – 104 °F (-20 – 40 °C).
- 2) For best results, store the UPS in the original shipping container and place on a wood or metal pallet.
- 3) The optimum storage temperature is 70 °F (21 °C). Higher ambient temperatures cause UPS batteries to need recharging more frequently.
- 4) If stored in an ambient temperature under 68 °F (20 °C), recharge the batteries every 9 months.
- 5) If stored in an ambient temperature of 68 – 86 °F (20 – 30 °C), recharge the batteries every 6 months.
- 6) If stored in an ambient temperature of 86 – 104 °F (30 – 40 °C), recharge the batteries every 3 months.

2.5 Disposal

Please contact your state environmental agency for details on proper disposal of electrical components and packaging in your particular area.



ATTENTION

It is ILLEGAL to dump lead-acid batteries in landfills or dispose of improperly. Please help our Earth by contacting the environmental protection agencies in your area, the battery manufacturer, or call TOSHIBA toll-free at (877) 867-8773 for more information about recycling batteries.

3.0 Installation Precautions

Based on the 4200FA UPS external dimensions and the way the outer panels are removed; minimum amounts of unobstructed space around the unit are necessary for ventilation and maintenance access. The following section and Fig. 3.1 shows the minimum clearances required for proper UPS site installation.

3.1 Equipment Placement

- 1) Do not install the UPS on an inclined surface, or areas that are subject to frequent vibrations or jolting. This could damage UPS circuits.
- 2) Do not allow liquids or foreign objects to get inside the UPS.
- 3) Allow at least 20" (500 mm) on the front side and 6" (152 mm) on the rear and sides of the UPS unit for air ventilation and maintenance access.
- 4) Do not install the UPS in a location that is subject to high humidity. Also, do not install the unit in areas that are exposed to direct sunlight, or contaminated areas subject to high levels of airborne dust, metal particles, or flammable gasses.
- 5) Verify the ventilation and air conditioning system at the site is capable of removing the heat generated by the UPS.

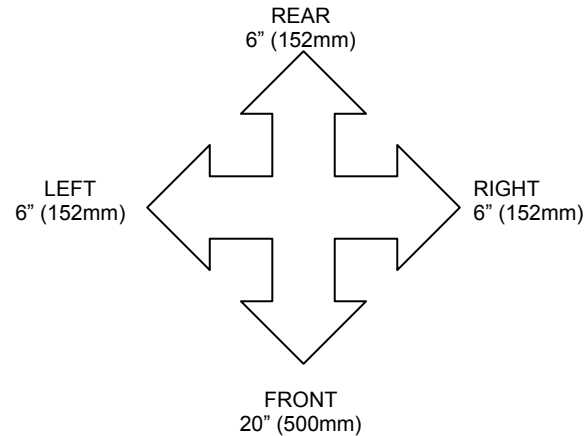

Fig 3.1

Ambient temperature range for operating the UPS is 32 – 104 °F (0 – 40 °C); **77 °F (25 °C) is the recommended operating temperature for maximum battery life.**



- 6) Avoid installation near sources of electrical noise. Always make sure that the unit's ground is intact to prevent **electrical shock** and help prevent electrical noise.



- 7) This UPS generates and radiates radio-frequency energy during operation. Although RFI noise filters are installed inside the unit there is no guarantee that the UPS will not influence some sensitive devices, which are operating in near proximity. If such interference occurs, the UPS should either be installed farther away from the affected equipment and/or powered from a different source than the affected equipment.

3.2 System Preparation (Pre-Power)

Before connecting the UPS to a power source; move the Circuit Breakers (ON/OFF), on the front panel, to the OFF position and move the operation STOP/RUN key switch, on the front panel, to the STOP position.

3.3 Operating Precautions



- 1) The UPS should not be powered up until the entire User's Manual has been reviewed, and understood.
- 2) The input power source voltage must be within +10% to -15% of the rated input voltage to initially start the UPS. The input frequency must be within the rated input frequency range. Voltages and frequencies outside of the permissible range may cause internal protection devices to activate.
- 3) The UPS should not be used with a load whose rated input is greater than the rated UPS output.
- 4) Do not use the UPS to provide power to motors that require high starting current or a long starting time such as vacuum cleaners and machine tools.
- 5) Do not insert metal objects or combustible materials in the unit's ventilation slots.
- 6) Do not place, hang, or paste any objects on the top or on the exterior surfaces of the UPS.
- 7) The capacitors of the UPS maintain a residual charge for a while after turning off the UPS. The required discharge time for each UPS typeform is provided via a cabinet label and a **CHARGE LED**. Wait for at least the minimum time indicated on the label and ensure that the **CHARGE LED** has gone out before removing the front panel of the UPS once the UPS power has been turned off.
- 8) Do not attempt to disassemble, modify, or repair the UPS. Call TOSHIBA Service for repair information.
- 9) Turn the power on only after attaching **ALL** the covers and **DO NOT** remove any covers of the UPS when the power is on.
- 10) If the UPS should emit smoke or an unusual odor or sound, turn the power off immediately.
- 11) The heat sink and other components may become extremely hot to the touch. Allow the unit to cool before coming into contact with these items.
- 12) Warning signs should be placed on or near the load to let people know that the load is being powered by the UPS.

- 13) Additional warnings and notifications shall be posted at the equipment installation location as deemed required by **Qualified Personnel**.



CAUTION When the UPS is in the Inverter mode, turning the breaker to the OFF position will cause the unit to go into the battery backup mode. The UPS will continue to provide power to the load. The unit must be in Bypass mode and then the breaker turned to the OFF position for the UPS to shut down power to the load.



CAUTION Do not EPO (Emergency Power OFF) the UPS and then reset the breaker until the UPS has been fully discharged. The UPS could be damaged if the unit is not fully powered down before the breaker is reset.

4.0 UPS Connections

4.1 Power Connections

4.1.1 Power Connections 15/25/30 kVA with Internal Batteries

The following illustrates the wiring connections from the power distribution panel (not part of the UPS) to the terminal block of the 15/25/30 kVA UPS Models

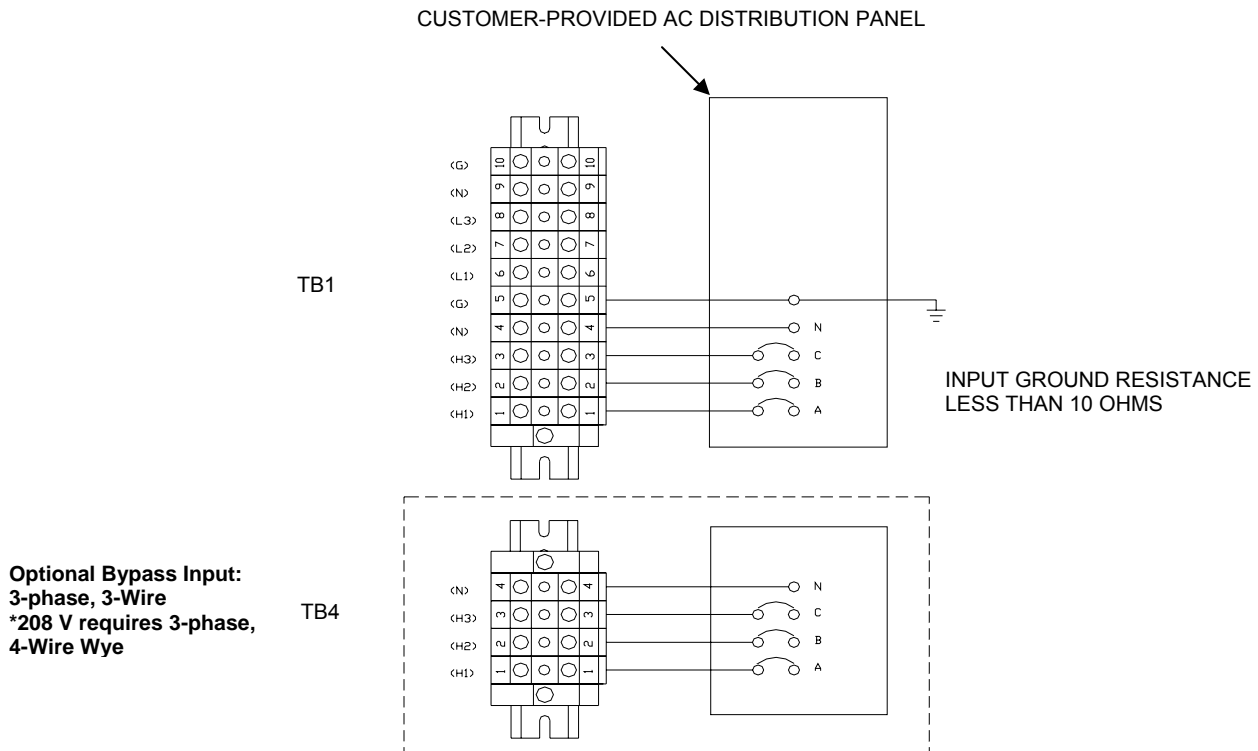

4.1.2 Power Connections 15/25/30 kVA with Internal Transformer

The following illustrates the wiring connections from the power distribution panel (not part of the UPS) to the terminal block of the 15/25/30 kVA UPS Models

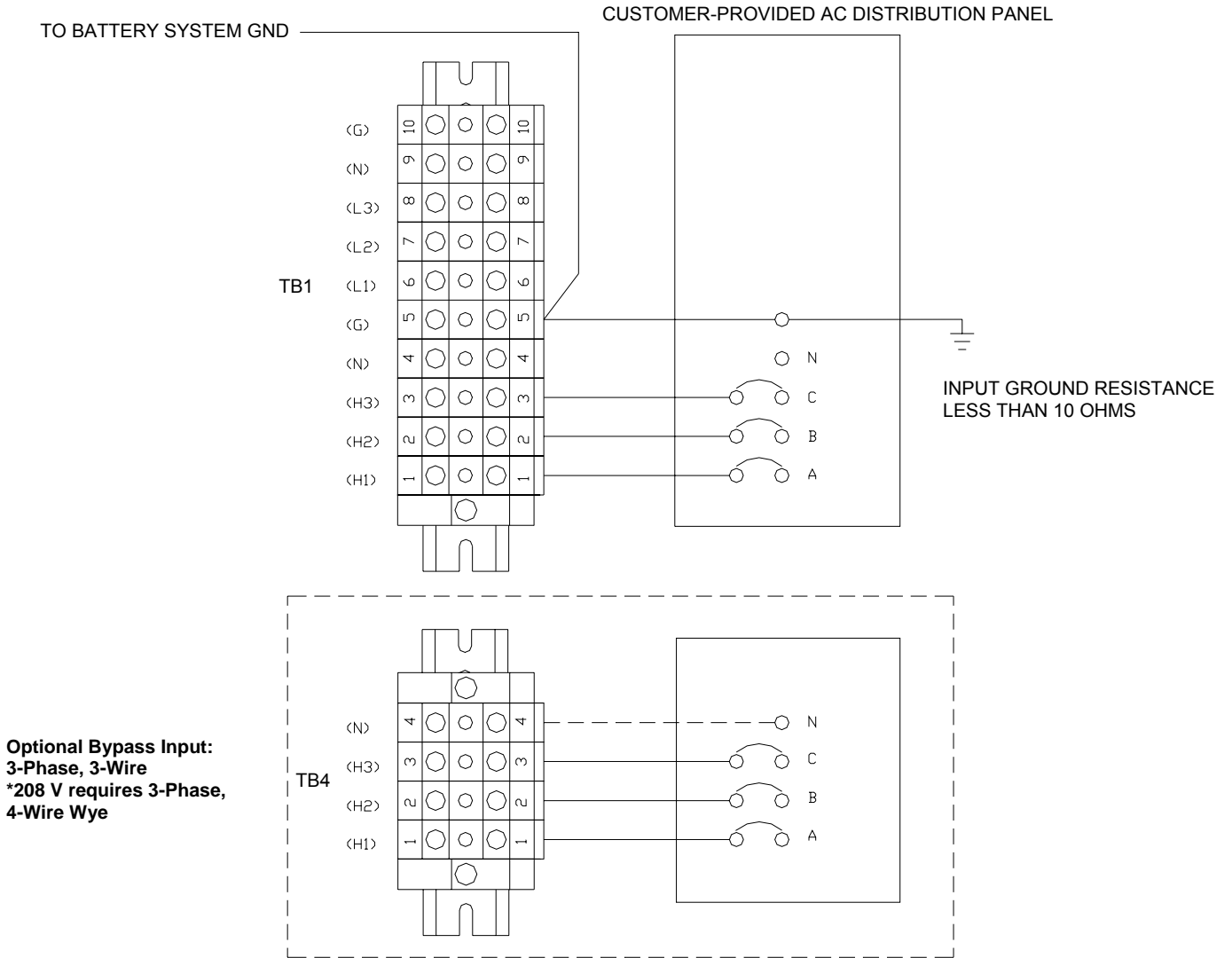

TOSHIBA

4.1.3 Recommended Wire Size and Torque Requirements UPS Input and Output Terminals

| Minimum Wire Size and Torque Requirements UPS Input and Output Terminals 15/25/30 kVA (USE MINIMUM 75 °C INSULATED COPPER WIRING) | | | | | | |
|-----------------------------------------------------------------------------------------------------------------------------------------|--------|------------|--------|------------|--------|------------|
| Phase: (A) (B) (C) Input: (H1) (H2) (H3) | 15 kVA | | 25 kVA | | 30 kVA | |
| | AWG | Torque | AWG | Torque | AWG | Torque |
| 208 V | 8 | 51 in-lbs. | 4 | 51 in-lbs. | 2 | 87 in-lbs. |
| 220 V | 8 | 51 in-lbs. | 4 | 51 in-lbs. | 2 | 87 in-lbs. |
| 240 V | 8 | 51 in-lbs. | 4 | 51 in-lbs. | 2 | 87 in-lbs. |
| 380 V | 10 | 35 in-lbs. | 8 | 51 in-lbs. | 6 | 51 in-lbs. |
| 400 V | 10 | 35 in-lbs. | 8 | 51 in-lbs. | 6 | 51 in-lbs. |
| 415 V | 10 | 35 in-lbs. | 8 | 51 in-lbs. | 6 | 51 in-lbs. |
| 480 V | 10 | 35 in-lbs. | 8 | 51 in-lbs. | 6 | 51 in-lbs. |
| 600 V | 10 | 35 in-lbs. | 10 | 35 in-lbs. | 10 | 35 in-lbs. |

All wire sizes are per the NEC. Maximum Wire Size is 2 AWG.

| Output: (L1) (L2) (L3) (N) | 15 kVA | | | | 25 kVA | | | | 30 kVA | | | |
|-------------------------------|----------------------|------------|----------------------------------------|-----|----------------------|------------|----------------------------------------|-----|----------------------|------------|----------------------------------------|-----|
| | AWG (L1)- (L3) | AWG (N) | Torque (inch-lbs.) (L1)-(L3) (N) | | AWG (L1)- (L3) | AWG (N) | Torque (inch-lbs.) (L1)-(L3) (N) | | AWG (L1)- (L3) | AWG (N) | Torque (inch-lbs.) (L1)-(L3) (N) | |
| 120/208 V | 8 | 4 | 51 | 51 | 4 | 2 | 51 | 87 | 2 | 2 | 87 | 87 |
| 127/220 V | 8 | 4 | 51 | 51 | 4 | 2 | 51 | 87 | 2 | 2 | 87 | 87 |
| 240 V | 8 | N/A | 51 | N/A | 4 | N/A | 51 | N/A | 2 | N/A | 87 | N/A |
| 220/380 V | 10 | 8 | 35 | 51 | 8 | 4 | 51 | 51 | 6 | 2 | 51 | 87 |
| 230/400 V | 10 | 8 | 35 | 51 | 8 | 4 | 51 | 51 | 6 | 2 | 51 | 87 |
| 240/415 V | 10 | 8 | 35 | 51 | 8 | 4 | 51 | 51 | 6 | 2 | 51 | 87 |
| 277/480 V | 10 | 8 | 35 | 51 | 8 | 6 | 51 | 51 | 6 | 2 | 51 | 87 |
| 600 V | 10 | N/A | 35 | N/A | 10 | N/A | 35 | N/A | 10 | N/A | 35 | N/A |

Neutral Conductors are rated @ 1.73 or 200% of phase conductors, per NEC. Maximum Wire Size is 2 AWG.

| Input/ Output (GND) | 15 kVA | | 25 kVA | | 30 kVA | |
|---------------------|--------|------------|--------|------------|--------|------------|
| | AWG | Torque | AWG | Torque | AWG | Torque |
| (G) | 10 | 35 in-lbs. | 8 | 51 in-lbs. | 6 | 51 in-lbs. |

Maximum Wire Size is 2 AWG.

| Minimum Wire Size and Torque Requirements UPS Optional Separate Bypass Input "TB4" 15 / 25kVA (USE MINIMUM 75 °C INSULATED COPPER WIRING) | | | | | | | |
|-------------------------------------------------------------------------------------------------------------------------------------------------|--------|------------|--------|------------|--------|------------|--|
| Phase: (A) (B) (C) Input: (H1) (H2) (H3) | 15 kVA | | 25 kVA | | 30 kVA | | |
| | AWG | Torque | AWG | Torque | AWG | Torque | |
| 208 V | 8 | 51 in-lbs. | 4 | 51 in-lbs. | 2 | 87 in-lbs. | |
| 220 V | 8 | 51 in-lbs. | 4 | 51 in-lbs. | 2 | 87 in-lbs. | |
| 240 V | 8 | 51 in-lbs. | 4 | 51 in-lbs. | 2 | 87 in-lbs. | |
| 380 V | 10 | 35 in-lbs. | 8 | 51 in-lbs. | 6 | 51 in-lbs. | |
| 400 V | 10 | 35 in-lbs. | 8 | 51 in-lbs. | 6 | 51 in-lbs. | |
| 415 V | 10 | 35 in-lbs. | 8 | 51 in-lbs. | 6 | 51 in-lbs. | |
| 480 V | 10 | 35 in-lbs. | 8 | 51 in-lbs. | 6 | 51 in-lbs. | |
| 600 V | 10 | 35 in-lbs. | 10 | 35 in-lbs. | 10 | 35 in-lbs. | |

Maximum Wire Size is 2 AWG.

4.1.4 Power Connection Cable Routing and Conduit Placement 15/25/30 kVA

The following illustrates the proper cable routing that should be followed during the power connection process of the 15/25/30 kVA.

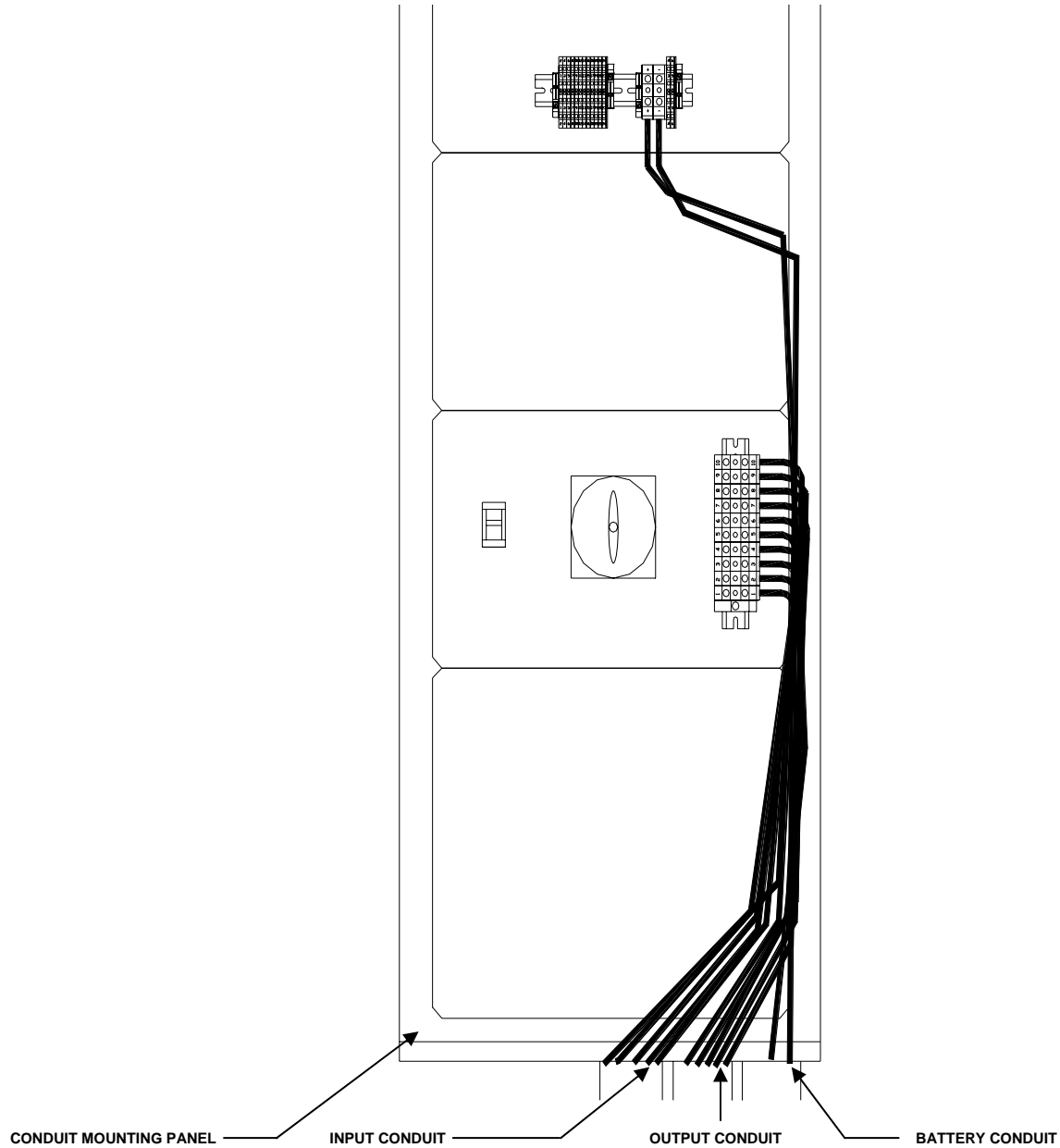

Note:

- 1) Input and Output conductors shall be installed in separate conduits, and installed in accordance with the latest edition of NEC and the Local Authority having jurisdiction.
- 2) Battery conductors shall be installed in a separate conduit and be of low resistance type.

4.2 Control Circuit and External Battery Interface Connections 15/25/30 kVA

The following illustrates the wiring connections of the Control Circuits, and Battery Interface Circuits.

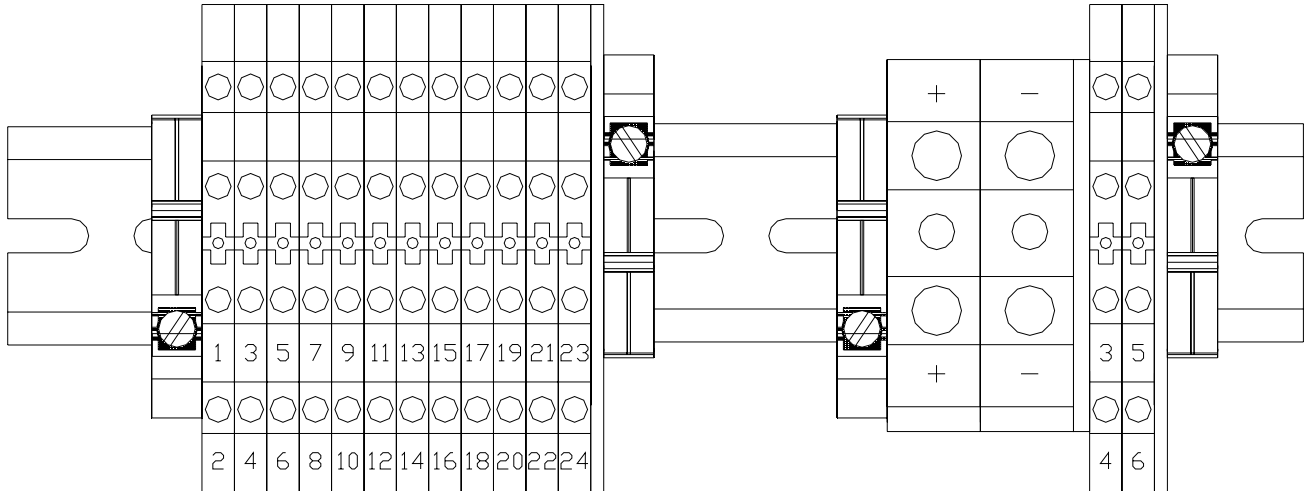

- (1) Low Battery
- (2) Battery Discharge
- (3) Fault
- (4) Not Used
- (5) Inverter Supply
- (6) Inverter Supply
- (7) P24A3
- (8) Remote Run
- (9) P24A3
- (10) Remote Stop
- (11) Bypass
- (12) COMMON
- (13) EPO
- (14) EPO

- Battery Connection**
- (+) Positive
 - (-) Negative
 - (3) Battery Shunt Trip
 - (4) Battery Shunt Trip
 - (5) Battery Aux.
 - (6) Battery Aux.

4.2.1 Recommended Wire Size and Torque Requirements UPS Control and Battery Interface 15/25/30 kVA

| Minimum Wire Size and Torque Requirements UPS Control and Battery Interface Circuits USE MINIMUM 75 °C COPPER WIRING | | |
|-----------------------------------------------------------------------------------------------------------------------------------|--------------|----------------------|
| TERMINAL (TERMINAL #) | 15/25/30 kVA | |
| | AWG | TIGHTENING TORQUE |
| UPS CONTROL CIRCUITS (1-24)* | 14-16 | 8 in-lbs. |
| BATTERY CONTROL CIRCUITS (3-6)* | 14-16 | 8 in-lbs. |
| BATTERY (+/-) | 4 | 51 in-lbs. |

*Indicates Class 1 wiring methods are to be used. Maximum Wire Size for Control Circuits is 12 AWG. Maximum for Battery is 2 AWG.

4.3 Power Connections 50 kVA

The following illustrates the wiring connections from the power distribution panel (not part of the UPS) to the terminal block of the 50 kVA UPS Model

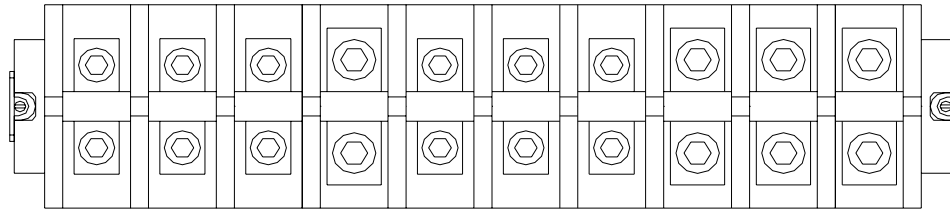

(H1) (H2) (H3) (N) (L1) (L2) (L3) (N) (+) (-)

INPUT: 3-phase, 3-wire
208 V requires 3-phase,
4-wire

OUTPUT: 3-phase (4-wire)

TB1

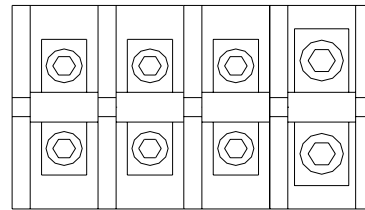

(H1) (H2) (H3) (N)

Optional: Bypass Input:
3-phase, 3-wire
208 V requires 3-phase,
4-wire

TB4

TOSHIBA

4.3.1 Recommended Wire Size and Torque Requirements For UPS Input and Output Terminals

Minimum Wire Size and Torque Requirements
UPS Input and Output Terminals 50 kVA
(USE MINIMUM 75 °C INSULATED COPPER WIRING)

| INPUT: | | | OUTPUT: | | | |
|----------------|-----|-------------|--------------|-----|-------------|-------------------|
| (H1) (H2) (H3) | AWG | NEUTRAL AWG | (L1)(L2)(L3) | AWG | NEUTRAL AWG | Tightening Torque |
| 208 V | 1/0 | 250MCM | 208/120 V | 1/0 | 250MCM | 200 in-lbs. |
| 220 V | 1/0 | 4/0 | 220/127 V | 1/0 | 4/0 | 200 in-lbs. |
| 240 V | 1 | N/A | 240 V | 1 | N/A | 200 in-lbs. |
| 380 V | 4 | 1/0 | 380/220 V | 4 | 1/0 | 200 in-lbs. |
| 400 V | 4 | 1/0 | 400/230 V | 4 | 1/0 | 200 in-lbs. |
| 415 V | 4 | 1 | 415/240 V | 4 | 1 | 200 in-lbs. |
| 480 V | 6 | 2 | 480/277 V | 6 | 2 | 200 in-lbs. |
| 600 V | 6 | N/A | 600 V | 6 | N/A | 200 in-lbs. |

All wire sizes are per the NEC. Maximum Wire Size for Input and Output is 1/0 AWG. Neutral Conductors are rated @ 1.73 or 200% of phase conductors, per NEC. Maximum Wire Size for Neutral is 250MCM.

| Input/ Output (GND) | 50 kVA | |
|---------------------|--------|-------------------|
| | AWG | Tightening Torque |
| 208-240 VAC | 6 | 200 in-lbs. |
| 380-480 VAC | 6 | 200 in-lbs. |
| 600 VAC | 8 | 200 in-lbs. |

| Battery (+) / (-) | 50 kVA | |
|-------------------|--------|-------------------|
| | AWG | Tightening Torque |
| (+) (-) | 250MCM | 200 in-lbs. |

Maximum Wire Size for Battery is 250MCM.

| Minimum Wire Size and Torque requirements UPS Optional Bypass Input Terminals TB4 50 kVA (USE MINIMUM 75 °C INSULATED COPPER WIRING) | | | |
|---------------------------------------------------------------------------------------------------------------------------------------------------|--------|-------------|-------------------|
| Phase: (A) (B) (C) Input: (H1) (H2) (H3) | 50 kVA | | |
| | AWG | NEUTRAL AWG | Tightening Torque |
| 208/120 V | 1/0 | 250MCM | 200 in-lbs. |
| 220 V | 1/0 | 4/0 | 200 in-lbs. |
| 240 V | 1 | N/A | 200 in-lbs. |
| 380 V | 4 | 1/0 | 200 in-lbs. |
| 400 V | 4 | 1/0 | 200 in-lbs. |
| 415 V | 4 | 1 | 200 in-lbs. |
| 480 V | 6 | 2 | 200 in-lbs. |
| 600 V | 6 | N/A | 200 in-lbs. |

Maximum Wire Size for Input is 1/0 AWG. Maximum Wire Size for Neutral is 250MCM.

4.3.2 Power Connection Cable Routing and Conduit Placement 50 kVA

The following illustrates the proper cable routing that should be followed during the power connection process for the 50kVA.

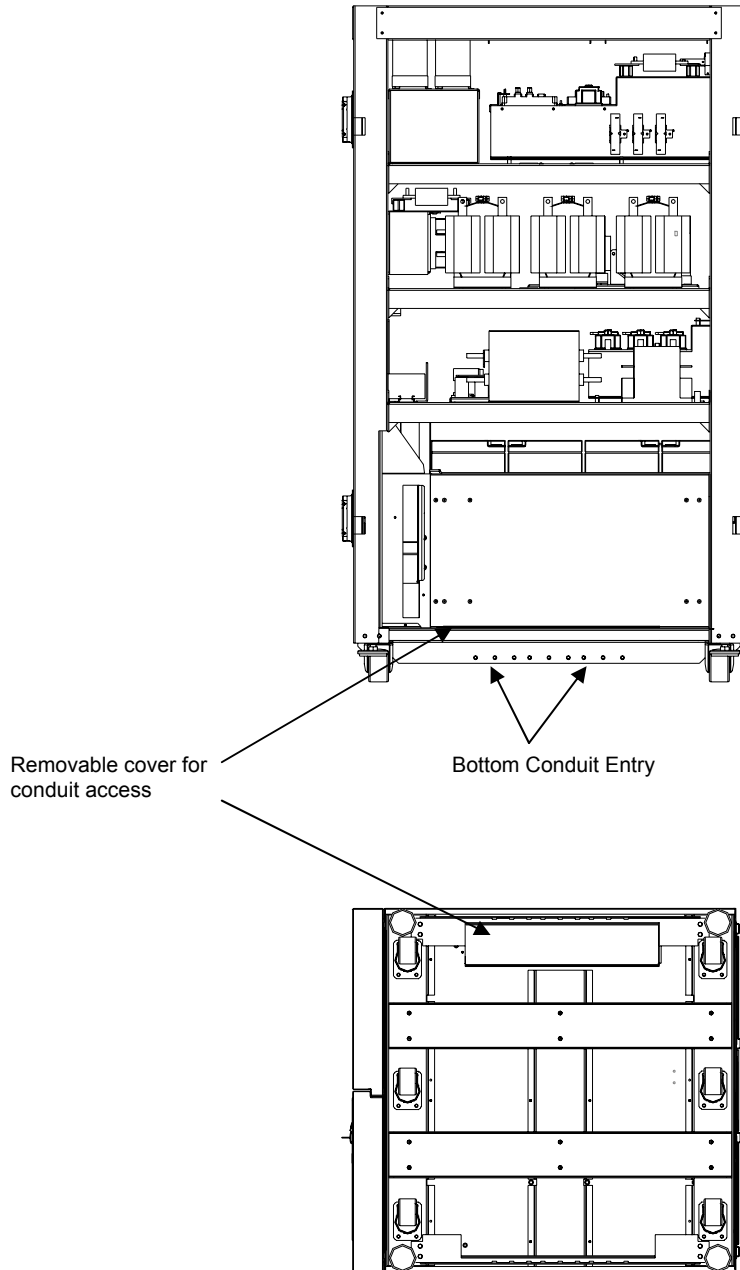

4.4 Control Circuit and External Interface Connections 50 kVA

The following illustrates the wiring connections of the Control Circuits, and Battery Interface Circuits for the 50kVA.

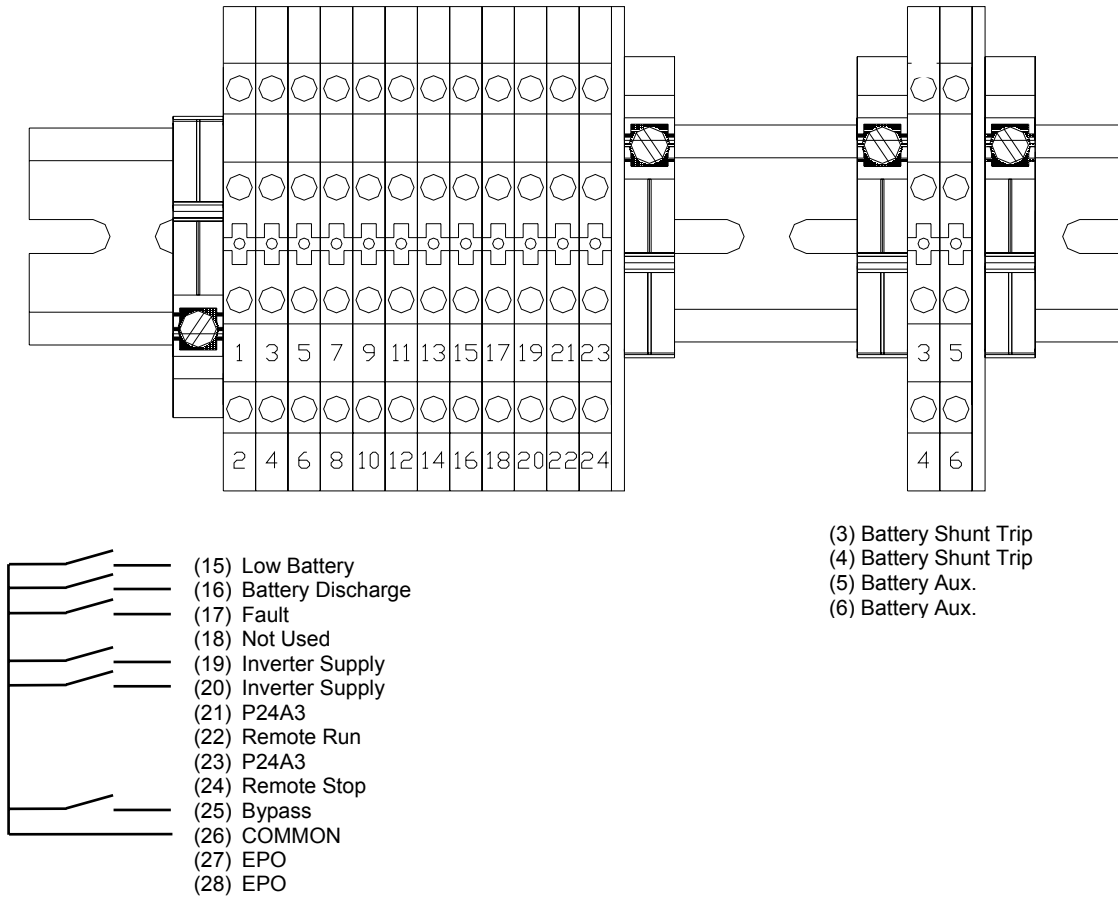

4.4.1 Recommended Wire Size and Torque Requirements UPS Control and Battery Interface 50 kVA

| Minimum Wire Size and Torque Requirements UPS Control and Battery Interface Circuits USE MINIMUM 75 °C COPPER WIRING | | |
|-----------------------------------------------------------------------------------------------------------------------------------|--------|----------------------|
| TERMINAL (TERMINAL #) | 50 kVA | |
| | AWG | TIGHTENING TORQUE |
| UPS CONTROL CIRCUITS (1-24)* | 14-16 | 8 in-lbs. |
| BATTERY CONTROL CIRCUITS (3-6)* | 14-16 | 8 in-lbs. |

*Indicates Class 1 wiring methods are to be used. Maximum Wire Size is 12 AWG.

4.5 Communication Interface

4.5.1 Remote Contact

This interface is a standard feature and is available as dry switch contacts through a DB9 male connector located on the front of the UPS. The following schematic shows the contact state and pin assignment for each signal and the associated DB9 connector pin-out.

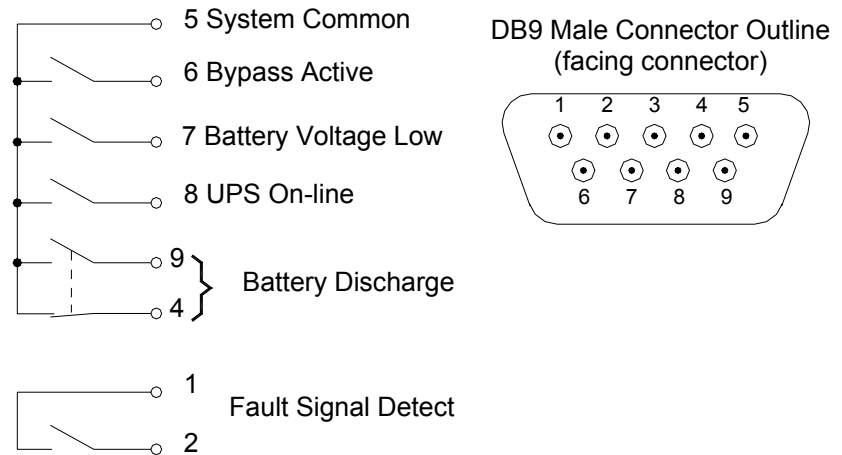

Notes:

- 1) Pin "switches" are shown in their **inactive states**. **Example:** (if battery voltage is low, pin 7 will be connected to System Common).
- 2) Contacts are rated at 30 VDC, 0.1 amps; 125 VAC, 3 amps.
- 3) Pin number "3" is not used.

4.5.2 RS-232C

The RS-232C serial communication interface is available through a DB9 female connector located on the inside of the UPS. This interface allows control of the UPS from a computer network running TOSHIBA RemotEyell™ software. The computer and the UPS are connected through a serial RS-232C communication port. The available data from the UPS, via the RS-232C communication link, is shown below:

| | | |
|--------------------------------------------------------------|-------------------------------------------------------------------------------------------------------------------------------------------------------------------------------------------------------------------------------------------------------------|------------------------------------------------------|
| Operating Conditions | Input Voltage Input Frequency Battery Voltage | Output Voltage Output Frequency Output Current |
| UPS Operating Status (Described as "yes or "no") | Utility Power OK Low Battery Voltage Detected UPS in BYPASS Mode UPS in NORMAL Mode Input and Output Frequency Synchronized UPS FAULT Occurred | |
| Fault Details (Described as "occurred" or "not occurred") | DC Bus Over-Current DC Bus Over-Voltage DC Bus Under-Voltage Input Over-Current Overheat Overload Being Timed Overload (allowable time exceeded) Output Over-Voltage (during Normal Mode) Output Under-Voltage (during Normal Mode) | |

The connector pin assignment and female connector outline are illustrated below.

| Pin | I/O | Symbol | Description |
|-----|----------------------|--------|---------------------|
| 1 | This pin is not used | | |
| 2 | Input | RXD | Receive Data |
| 3 | Output | TXD | Transmit Data |
| 4 | Output | DTR | Data Terminal Ready |
| 5 | - | SG | Signal Ground |
| 6 | Input | DSR | Data Set Ready |
| 7 | Output | RTS | Request To Send |
| 8 | Input | CTS | Clear To Send |
| 9 | This pin is not used | | |

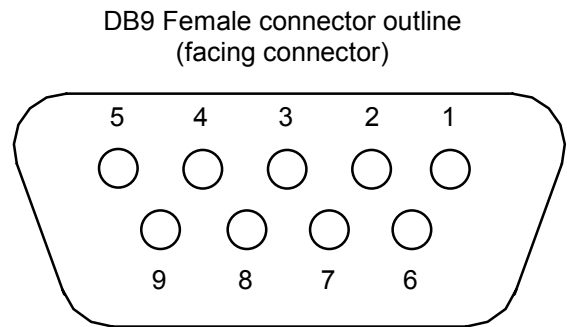

4.5.3 UPS Shutdown (via RS-232C)

When the UPS is operating from its internal batteries, a 'shutdown' order can be sent to the UPS instructing it to turn OFF after a user-specified amount of time. This function can allow you to stop discharging the UPS batteries after an orderly system shutdown has been completed. The UPS can be programmed to turn OFF up to 8 minutes after the 'shutdown' command is given. This command can be cancelled before the specified time has elapsed by following the directions listed on the RS-232C screen.

TOSHIBA

5.0 Specifications

5.1 4200FA 15 / 25 kVA @ 208 VAC Input/ 208 VAC Output w/Internal Batteries

| | Model Number | C42F3F150XAMBN C42F3F150##MBN | C42F3F250XAMBN C42F3F250##MBN | |
|---------------------------|-----------------------------------------------------------|-------------------------------------------------------------------------------------------------------------------|----------------------------------|--|
| | Rated Output Capacity | 15 kVA | 25 kVA | |
| | External Dimensions W x D x H (cm) | 20.0" x 36.3" x 59.7" (50.8 cm x 92.2 cm x 151.6 cm) | | |
| Input | Rated Voltage | 208 VAC | | |
| | Voltage Variation | +10% to -30%; (-15% to -30%) | | |
| | Rated Frequency | 50 / 60 Hz | | |
| | Input Cables required | 3 phase ; 4 Wire + GND | | |
| | Dual Input Option Cables required | 3 phase ; 4 Wire + GND | | |
| | * Power Factor | Greater than 0.98 when in inverter mode | | |
| | Required Input kVA | 15 kVA | 24 kVA | |
| | Walk-in Function | From 20% to 100% over 5 seconds | | |
| | Inrush Current | Less than 8 times the rated current under synchronous operation | | |
| | Current Limit | 115% maximum | | |
| | * Harmonic Currents | Less than 8.5% | Less than 5.5% | |
| | Battery | DC Nominal (Voltage Range) | 288 VDC (216 to 332 VDC) | |
| | | Float Charge (Regulation) | 324.0 VDC (± 2%) | |
| Ripple Voltage | | 0.5 V R.M.S. | | |
| **Rated Back-up Time | | 7 min at full load | 5 min at full load | |
| Rated Charge Current | | 4.0 Amps | | |
| Output | Rated Voltage | 208 / 120 VAC | | |
| | Rated Current | 42.0 Amps | 69.5 Amps | |
| | Rated Power Factor | 0.8 lagging | | |
| | Output Cables Required | 3 phase ; 4 Wire + GND | | |
| | Voltage Regulation (phase-phase) | ± 2% (0-100% balanced load); ± 3% (0-100% unbalanced load) | | |
| | Voltage Adjustment Range | ± 5V Manually from the key pad | | |
| | Phase Displacement | ± 2° (0–100% balanced load); ± 4° (unbalanced load) | | |
| | Rated Frequency | 50 / 60 Hz | | |
| | Frequency Regulation | ± 0.1% in free running mode | | |
| | Frequency Synchronous | ± 0.5/1.0/1.5 Hz (± 1.0 Hz. std.) switch selectable by qualified technician | | |
| | Frequency Slew Rate | 1 Hz/s to 3Hz/s (in 0.5 Hz steps) | | |
| | Voltage Transients (Recovery time: 50 ms) | ± 5% (100% load step change); ± 3% (loss or return of input voltage); ± 8% (transfer of bypass to inverter) | | |
| | Inverter Overload Capacity | 125% 90 sec; 150% 30 sec | | |
| | Bypass Overload Capacity | 1000% 10 ms; 125% 10 min. | | |
| | Crest Factor | 2.5–3.0 within the kW range | | |
| | Neutral Line Conductor | 1.73 (200%) times line rating | | |
| | Harmonic Voltage Distortion | 1.5% max (linear load) | | |
| Inrush Current protection | Automatic Transfer to bypass, then retransfer to inverter | | | |
| Environment | Efficiency (Typical) | AC/DC/AC: 82%; DC/AC: 86% | AC/DC/AC: 85%; DC/AC: 87% | |
| | Heat loss to be removed | 8,428 BTU/hr (2,124 kcal/hr) | 11,489 BTU/hr (2,895 kcal/hr) | |
| | Audible Noise | 60dB (A) at 1 meter from the front of the unit | | |
| | Operating Temperature | 32 –104 °F (0 – 40 °C); optimal temperature is 77 °F (25 °C) | | |
| | Operating Humidity | 30–90% RH (non condensing) | | |
| Altitude *** | Less than 2000 meters | | | |

Items marked with an (*) are specified at rated conditions under balanced linear loads.

(**) Battery backup time may vary depending on the operating conditions and ambient temperature at the installation site, and an initial charge time of 24 hrs is necessary to obtain proper battery performance level before the unit is placed in operation.

(***) At 6600-ft (2000 m) above sea level, output capacity should be derated by 3% (Consult Factory for higher elevations).

TOSHIBA

5.2 4200FA 15/25 kVA w/Internal Transformer

| | | | | | |
|---------------------------------------|----------------------------------------------|-----------------------------------------------------------|-------------------------------------------------------------------------------------------------------------------|-------------------------------|--|
| | Model Number | | C42#3*150#AMXN | C42#3*250#AMXN | |
| | | Input | # =(B: 208; H: 220; C: 240; N: 380–415; D: 480; M: 600) VAC | | |
| | | Output | *=(F: 208; H: 220 wye; J: 240; P: 380–415 wye; K: 480 wye; M:600) | | |
| | Rated Output Capacity | | 15 kVA | 25 kVA | |
| External Dimensions W x D x H (cm) | | 20.0" x 36.3" x 59.7" (50.8 cm x 92.2 cm x 151.6 cm) | | | |
| Input | Rated Voltage | | 208; 220; 240; 380; 400; 415; 480; 600 VAC (Determined by Input Transformer internal to the unit) | | |
| | Voltage Variation | | +10% to -30%; (-15% to -30%) | | |
| | Rated Frequency | | 50/60 Hz | | |
| | Input Cables Required | | 3 phase ; 3 Wire + GND | | |
| | Dual Input Option Cables required | | 3 phase ; 4 Wire + GND | | |
| | * Power Factor | | Greater than 0.98 when in inverter mode | | |
| | Required Input kVA | | 16 kVA | 26 kVA | |
| | Walk-in Function | | From 20% to 100% over 5 seconds | | |
| | Inrush Current | | Less than 8 times the rated current under synchronous operation | | |
| | Current Limit | | 115% maximum | | |
| | * Harmonic Currents | | Less than 8.5% | Less than 5.5% | |
| | Battery | DC Nominal (Voltage Range) | | 288 VDC (216 – 332 VDC) | |
| | | Float Charge (Regulation) | | 324.0 VDC (± 2%) | |
| Ripple Voltage | | 0.5 V R.M.S. | | | |
| **Rated Back-up Time | | Refer to Battery System Manual | | | |
| Rated Charge Current | | 10.0 Amps | | | |
| Output | Rated Voltage | | (Determined by Output Transformer internal to the unit) | | |
| | Rated Current | | VA / Nominal Output Voltage / 1.73 | | |
| | Rated Power Factor | | 0.8 lagging | | |
| | Output Cables Required | | 3 phase ; 4 Wire + GND | | |
| | Voltage Regulation (phase-phase) | | ± 5% (0–100% balanced load); ± 6% (0-100% unbalanced load) | | |
| | Voltage Adjustment Range | | ± 5V Manually from key pad | | |
| | Phase Displacement | | ± 2° (0–100% balanced load); ± 4° (unbalanced load) | | |
| | Rated Frequency | | 50 / 60 Hz | | |
| | Frequency Regulation | | ± 0.1% in free running mode | | |
| | Frequency Synchronous | | ± 0.5/1.0/1.5 Hz (± 1.0 Hz. std.) switch selectable by qualified technician | | |
| | Frequency Slew Rate | | 1 Hz/s to 3Hz/s (in 0.5 Hz steps) | | |
| | Voltage Transients (Recovery time: 50 ms) | | ± 5% (100% load step change); ± 3% (loss or return of input voltage); ± 8% (transfer of bypass to inverter) | | |
| | Inverter Overload Capacity | | 125% 90 sec; 150% 30 sec | | |
| | Bypass Overload Capacity | | 1000% 10ms; 125% 10 min. | | |
| | Crest Factor | | 2.5–3.0 within the kW range | | |
| | Neutral Line Conductor | | 1.73 (200%) times line rating | | |
| | Harmonic Voltage Distortion | | 1.5% max (linear load) | | |
| Inrush Current protection | | Automatic Transfer to bypass, then retransfer to inverter | | | |
| Environment | Efficiency (Typical) | | AC/DC/AC: 75%; DC/AC: 82% | AC/DC/AC: 77%; DC/AC: 83% | |
| | Heat loss to be removed | | 12,662 BTU/hr (3,190 kcal/hr) | 19,041 BTU/hr (4,797 kcal/hr) | |
| | Audible Noise | | 60dB (A) at 1 meter from the front of the unit | | |
| | Operating Temperature | | 32 – 104 °F (0 – 40 °C); optimal temperature is 77 °F (25 °C) | | |
| | Operating Humidity | | 30– 90% RH (non condensing) | | |
| | Altitude *** | | Less than 2000 meters | | |

Items marked with an (*) are specified at rated conditions under balanced linear loads.

(**) Battery backup time may vary depending on the operating conditions and ambient temperature at the installation site, and an initial charge time of 24 hrs is necessary to obtain proper battery performance level before the unit is placed in operation.

(***) At 6600-ft (2000 m) above sea level, output capacity should be derated by 3% (Consult Factory for higher elevations).

TOSHIBA

5.3 4200FA 30 kVA @ 208 VAC Input/ 208 VAC Output w/Internal Batteries

| | | |
|--------------|----------------------------------------------|-------------------------------------------------------------------------------------------------------------------|
| | Model Number | T42F3F300XAMBN T42F3F300##MBN |
| | Rated Output Capacity | 30 kVA |
| | External Dimensions W x D x H (cm) | 20.0" x 36.3" x 59.7" (50.8 cm x 92.2 cm x 151.6 cm) |
| Input | Rated Voltage | 208 VAC |
| | Voltage Variation | +10% to -30%; (-15% to -30%) |
| | Rated Frequency | 50 / 60 Hz |
| | Input Cables required | 3 phase ; 4 Wire + GND |
| | Dual Input Option Cables required | 3 phase ; 4 Wire + GND |
| | * Power Factor | Greater than 0.98 when in inverter mode |
| | Required Input kVA | 28.0 kVA |
| | Walk-in Function | From 20% to 100% over 5 seconds |
| | Inrush Current | Less than 8 times the rated current under synchronous operation |
| | Current Limit | 115% maximum |
| | * Harmonic Currents | Less than 3% THD |
| Battery | DC Nominal (Voltage Range) | 288 VDC (216 to 332 VDC) |
| | Float Charge (Regulation) | 324.0 VDC (± 2%) |
| | Ripple Voltage | 0.5 V R.M.S. |
| | **Rated Back-up Time | 4 min at full load |
| | Rated Charge Current | 4.0 Amps |
| Output | Rated Voltage | 208 / 120 VAC |
| | Rated Current | 83.4 Amps |
| | Rated Power Factor | 0.8 lagging |
| | Output Cables Required | 3 phase ; 4 Wire + GND |
| | Voltage Regulation (phase-phase) | ± 2% (0–100% balanced load); ± 3% (0–100% unbalanced load) |
| | Voltage Adjustment Range | ± 5V Manually from the key pad |
| | Phase Displacement | ± 2° (0–100% balanced load); ± 4° (unbalanced load) |
| | Rated Frequency | 50 / 60 Hz |
| | Frequency Regulation | ± 0.1% in free running mode |
| | Frequency Synchronous | ± 0.5/1.0/1.5 Hz (± 1.0 Hz. std.) switch selectable by qualified technician |
| | Frequency Slew Rate | 1 Hz/s to 3Hz/s (in 0.5 Hz steps) |
| | Voltage Transients (Recovery time: 50 ms) | ± 5% (100% load step change); ± 3% (loss or return of input voltage); ± 8% (transfer of bypass to inverter) |
| | Inverter Overload Capacity | 125% 90 sec; 150% 30 sec |
| | Bypass Overload Capacity | 1000% 10 ms; 125% 10 min. |
| | Crest Factor | 2.5–3.0 within the kW range |
| | Neutral Line Conductor | 1.73 (200%) times line rating |
| | Harmonic Voltage Distortion | 1.5% max (linear load) |
| | Inrush Current protection | Automatic Transfer to bypass, then retransfer to inverter |
| Environment | Efficiency (Typical) | AC/DC/AC: 85%; DC/AC: 87% |
| | Heat loss to be removed | 13,234 BTU/hr (3,334 kcal/hr) |
| | Audible Noise | 60dB (A) at 1 meter from the front of the unit |
| | Operating Temperature | 32–104 °F (0 – 40 °C); optimal temperature is 77 °F (25 °C) |
| | Operating Humidity | 30–90% RH (non condensing) |
| Altitude *** | Less than 6600 ft (2000 m) | |

Items marked with an (*) are specified at rated conditions under balanced linear loads.

(**) Battery backup time may vary depending on the operating conditions and ambient temperature at the installation site, and an initial charge time of 24 hrs is necessary to obtain proper battery performance level before the unit is placed in operation.

(***) At 6600-ft (2000 m) above sea level, output capacity should be derated by 3% (Consult Factory for higher elevations).

TOSHIBA

5.4 4200FA 30 kVA w/Internal Transformer

| | | | |
|---------------------------------------|----------------------------------------------|-----------------------------------------------------------|-------------------------------------------------------------------------------------------------------------------|
| | Model Number | | T42#3*300#AMXN |
| | | Input | # =(B: 208; H: 220; C: 240; N: 380–415; D: 480; M: 600) VAC |
| | | Output | *=(F: 208; H: 220 wye; J: 240; P: 380–415 wye; K: 480 wye; M:600) |
| | Rated Output Capacity | | 30 kVA |
| External Dimensions W x D x H (cm) | | 20.0" x 36.3" x 59.7" (50.8 cm x 92.2 cm x 151.6 cm) | |
| Input | Rated Voltage | | 208; 220; 240; 380; 400; 415; 480; 600 VAC (Determined by Input Transformer internal to the unit) |
| | Voltage Variation | | +10% to -30%; (-15% to -30%) |
| | Rated Frequency | | 50/60 Hz |
| | Input Cables Required | | 3 phase ; 3 Wire + GND |
| | Dual Input Option Cables required | | 3 phase ; 4 Wire + GND |
| | * Power Factor | | Greater than 0.98 when in inverter mode |
| | Required Input kVA | | 30.5 kVA |
| | Walk-in Function | | From 20% to 100% over 5 seconds |
| | Inrush Current | | Less than 8 times the rated current under synchronous operation |
| | Current Limit | | 115% maximum |
| | * Harmonic Currents | | Less than 3% THD |
| Battery | DC Nominal (Voltage Range) | | 288 VDC (216 to 332 VDC) |
| | Float Charge (Regulation) | | 324.0 VDC (± 2%) |
| | Ripple Voltage | | 0.5 V R.M.S. |
| | **Rated Back-up Time | | Refer to Battery System Manual |
| | Rated Charge Current | | 10.0 Amps |
| Output | Rated Voltage | | (Determined by Output Transformer internal to the unit) |
| | Rated Current | | VA / Nominal Output Voltage / 1.73 |
| | Rated Power Factor | | 0.8 lagging |
| | Output Cables Required | | 3 phase ; 4 Wire + GND |
| | Voltage Regulation (phase-phase) | | ± 5% (0-100% balanced load); ± 6% (0-100% unbalanced load) |
| | Voltage Adjustment Range | | ± 5V Manually from key pad |
| | Phase Displacement | | ± 2° (0–100% balanced load); ± 4° (unbalanced load) |
| | Rated Frequency | | 50 / 60 Hz |
| | Frequency Regulation | | ± 0.1% in free running mode |
| | Frequency Synchronous | | ± 0.5/1.0/1.5 Hz (± 1.0 Hz. std.) switch selectable by qualified technician |
| | Frequency Slew Rate | | 1 Hz/s to 3Hz/s (in 0.5 Hz steps) |
| | Voltage Transients (Recovery time: 50 ms) | | ± 5% (100% load step change); ± 3% (loss or return of input voltage); ± 8% (transfer of bypass to inverter) |
| | Inverter Overload Capacity | | 125% 90 sec; 150% 30 sec |
| | Bypass Overload Capacity | | 1000% 10ms; 125% 10 min. |
| | Crest Factor | | 2.5–3.0 within the kW range |
| | Neutral Line Conductor | | 1.73 (200%) times line rating |
| | Harmonic Voltage Distortion | | 1.5% max (linear load) |
| Inrush Current protection | | Automatic Transfer to bypass, then retransfer to inverter | |
| Environment | Efficiency (Typical) | | AC/DC/AC: 77%; DC/AC: 83% |
| | Heat loss to be removed | | 23,216 BTU/hr (5,849 kcal/hr) |
| | Audible Noise | | 60dB (A) at 1 meter from the front of the unit |
| | Operating Temperature | | 32°–104° F (0°–40° C); optimal temperature is 77° F (25° C) |
| | Operating Humidity | | 30–90% RH (non condensing) |
| | Altitude *** | | Less than 2000 meters |

Items marked with an (*) are specified at rated conditions under balanced linear loads.

(**) Battery backup time may vary depending on the operating conditions and ambient temperature at the installation site, and an initial charge time of 24 hrs is necessary to obtain proper battery performance level before the unit is placed in operation.

(***) At 6600-ft (2000 m) above sea level, output capacity should be derated by 3% (Consult Factory for higher elevations).

TOSHIBA

5.5 4200FA 50kVA @ 208 VAC Input/ 208 VAC Output w/Internal Batteries

| | | |
|---------------------------|-----------------------------------------------------------|-------------------------------------------------------------------------------------------------------------------|
| | Model Number | T42F3F500XAMBN T42F3F500##MBN |
| | Rated Output Capacity | 50 kVA |
| Input | External Dimensions W x D x H (cm) | 35.5" X 38.3" X 59.3" (90.1 cm x 97.2 cm x 150.6 cm) |
| | Rated Voltage | 208 VAC |
| | Voltage Variation | +10% to -30%; (-15% to -30%) **** |
| | Rated Frequency | 50 / 60 Hz |
| | Input Cables Required | 3 phase ; 4 Wire + GND |
| | Dual Input Option Cables required | 3 phase ; 4 Wire + GND |
| | * Power Factor | Greater than 0.98 when in inverter mode |
| | Required Input kVA | 46 kVA |
| | Walk-in Function | From 20% to 100% over 5 seconds |
| | Inrush Current | Less than 8 times the rated current under synchronous operation |
| | Current Limit | 115% maximum |
| | * Harmonic Currents | Less than 3% THD |
| | Battery | DC Nominal (Voltage Range) |
| Float Charge (Regulation) | | 324.0 VDC (± 2%) |
| Ripple Voltage | | 0.5 V R.M.S. |
| **Rated Back-up Time | | 5 min. at full load |
| Rated Charge Current | | 11.5 Amps |
| Output | Rated Voltage | 208 / 120 VAC |
| | Rated Current | 138.9 Amps |
| | Rated Power Factor | 0.8 lagging |
| | Output Cables Required | 3 phase ; 4 Wire + GND |
| | Voltage Regulation (phase-phase) | ± 2% (0–100% balanced load); ± 3% (0–100% unbalanced load) |
| | Voltage Adjustment Range | ± 5V Manually from key pad |
| | Phase Displacement | ± 2° (0–100% balanced load); ± 4° (unbalanced load) |
| | Rated Frequency | 50 / 60 Hz |
| | Frequency Regulation | ± 0.1% in free running mode |
| | Frequency Synchronous | ± 0.5/1.0/1.5 Hz (± 1.0 Hz. std.) switch selectable by qualified technician |
| | Frequency Slew Rate | 1 Hz/s to 3Hz/s(in 0.5 Hz steps) |
| | Voltage Transients (Recovery time: 50 ms) | ± 5% (100% load step change); ± 3% (loss or return of input voltage); ± 8% (transfer of bypass to inverter) |
| | Inverter Overload Capacity | 125% 90 sec; 150% 30 sec |
| | Bypass Overload Capacity | 1000% 10 ms; 125% 10 min. |
| | Crest Factor | 2.5–3.0 within the kW range |
| | Neutral Line Conductor | 1.73 (200%) times line rating |
| | Harmonic Voltage Distortion | 1.5% max (linear load) |
| Inrush Current protection | Automatic Transfer to bypass, then retransfer to inverter | |
| Environment | Efficiency (Typical) | AC/DC/AC: 88%; DC/AC: 89% |
| | Heat loss to be removed | 17,611 BTU/hr (4,437 kcal/hr) |
| | Audible Noise | ~65dB @ 1 meter from the front of the unit |
| | Operating Temperature | 32 – 104 °F (0 – 40 °C); optimal temperature is 77 °F (25 °C) |
| | Operating Humidity | 30–90% RH (non condensing) |
| Altitude *** | Less than 2000 meters | |

Items marked with an (*) are specified at rated conditions under balanced linear loads.

(**) Battery backup time may vary depending on the operating conditions and ambient temperature at the installation site, and an initial charge time of 24 hrs is necessary to obtain proper battery performance level before the unit is placed in operation.

(***) At 6600-ft (2000 m) above sea level, output capacity should be derated by 3% (Consult Factory for higher elevations).

(****) Prolonged operation at this level requires some derating of the output capacity.

TOSHIBA

5.6 4200FA 50kVA w/Internal Transformer

| | | | |
|---------------------------------------|----------------------------------------------|-----------------------------------------------------------|-------------------------------------------------------------------------------------------------------------------|
| | Model Number | | T42#3*500#AMXN |
| | | Input | # =(B: 208; H: 220; C: 240; N: 380–415; D: 480; M: 600) VAC |
| | | Output | *=(F: 208; H: 220 wye; J: 240; P: 380–415 wye; K: 480 wye; M:600) |
| | Rated Output Capacity | | 50 kVA |
| External Dimensions W x D x H (cm) | | 35.5" X 38.3" X 59.3" (90.1 cm x 97.2 cm x 150.6 cm) | |
| Input | Rated Voltage | | 208 VAC |
| | Voltage Variation | | +10% to -30%; (-15% to -30%) **** |
| | Rated Frequency | | 50 / 60 Hz |
| | Input Cables Required | | 3 phase ; 3 Wire + GND |
| | Dual Input Option Cables required | | 3 phase ; 4 Wire + GND |
| | * Power Factor | | Greater than 0.98 when in inverter mode |
| | Required Input kVA | | 50 kVA |
| | Walk-in Function | | From 20% to 100% over 5 seconds |
| | Inrush Current | | Less than 8 times the rated current under synchronous operation |
| | Current Limit | | 115% maximum |
| * Harmonic Currents | | Less than 3% THD | |
| Battery | DC Nominal (Voltage Range) | | 288 VDC (216 to 332 VDC) |
| | Float Charge (Regulation) | | 324.0 VDC (± 2%) |
| | Ripple Voltage | | 0.5 V R.M.S. |
| | **Rated Back-up Time | | Refer to Battery System Manual |
| | Rated Charge Current | | 11.5 Amps |
| Output | Rated Voltage | | (Determined by Output Transformer internal to the unit) |
| | Rated Current | | VA / Nominal Output Voltage / 1.73 |
| | Rated Power Factor | | 0.8 lagging |
| | Output Cables Required | | 3 phase ; 4 Wire + GND |
| | Voltage Regulation (phase-phase) | | ± 2% (0–100% balanced load); ± 3% (0–100% unbalanced load) |
| | Voltage Adjustment Range | | ± 5V Manually from key pad |
| | Phase Displacement | | ± 2° (0–100% balanced load); ± 4° (unbalanced load) |
| | Rated Frequency | | 50 / 60 Hz |
| | Frequency Regulation | | ± 0.1% in free running mode |
| | Frequency Synchronous | | ± 0.5/1.0/1.5 Hz (± 1.0 Hz. std.) switch selectable by qualified technician |
| | Frequency Slew Rate | | 1 Hz/s to 3Hz/s(in 0.5 Hz steps) |
| | Voltage Transients (Recovery time: 50 ms) | | ± 5% (100% load step change); ± 3% (loss or return of input voltage); ± 8% (transfer of bypass to inverter) |
| | Inverter Overload Capacity | | 125% 90 sec; 150% 30 sec |
| | Bypass Overload Capacity | | 1000% 10 ms; 125% 10 min. |
| | Crest Factor | | 2.5–3.0 within the kW range |
| | Neutral Line Conductor | | 1.73 (200%) times line rating |
| | Harmonic Voltage Distortion | | 1.5% max (linear load) |
| Inrush Current protection | | Automatic Transfer to bypass, then retransfer to inverter | |
| Environment | Efficiency (Typical) | | AC/DC/AC: 81%; DC/AC: 85% |
| | Heat loss to be removed | | 30,874 BTU/hr (7,778 kcal/hr) |
| | Audible Noise | | ~65dB @ 1 meter from the front of the unit |
| | Operating Temperature | | 32 – 104 °F (0 – 40 °C); optimal temperature is 77 °F (25 °C) |
| | Operating Humidity | | 30–90% RH (non condensing) |
| Altitude *** | | Less than 2000 meters | |

Items marked with an (*) are specified at rated conditions under balanced linear loads.

(**) Battery backup time may vary depending on the operating conditions and ambient temperature at the installation site, and an initial charge time of 24 hrs is necessary to obtain proper battery performance level before the unit is placed in operation.

(***) At 6600-ft (2000 m) above sea level, output capacity should be derated by 3% (Consult Factory for higher elevations).

(****) Prolonged operation at this level requires some derating of the output capacity.

6.0 Operating the UPS

6.1 AC Input Mode (Normal Operation)

The following illustration shows circuit power flow when the UPS is operating normally in the AC Input Mode. The converter of the UPS, including a boost chopper circuit, converts the AC input power into DC power. The boost chopper circuit maintains a constant voltage and provides current limiting for charging the batteries. It also supplies a DC voltage of the proper level to the inverter section. The inverter section generates a high quality sine wave output voltage. The batteries are maintained in a constantly charged state when the UPS is in the "Normal Operation Mode."

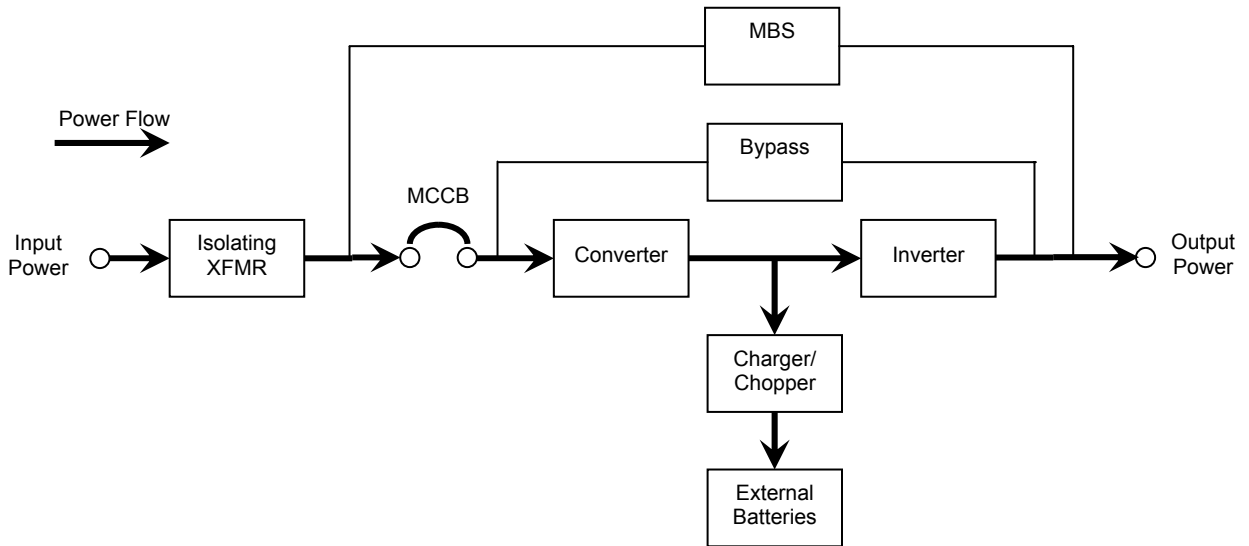

Power flow in AC Input Mode

6.2 Bypass Mode

If the UPS unit is severely overloaded or develops an internal fault, power flow is automatically switched from the main circuit to the Bypass circuit. Power flow through the bypass is shown in the following illustration. This changeover occurs automatically in less than 4 milliseconds in phase (Make-Before-Break). If the power flow is transferred to the Bypass circuit because of an overload and that overload condition ends within a specified period of time, then the power flow will "re-transfer" to the AC Input Mode (Normal Operation) automatically. **If the power flow is transferred to the Bypass circuit due to a fault condition, then the power flow must be transferred manually from the UPS's Bypass circuit back to the Inverter circuit after repairing the fault** (see "Start-up Procedure"). **If the power flow is transferred to the Bypass circuit due to an overload condition, then the power flow will automatically transfer from the UPS's Bypass circuit back to the Inverter circuit after removing the overload** (see "Overload Operation").

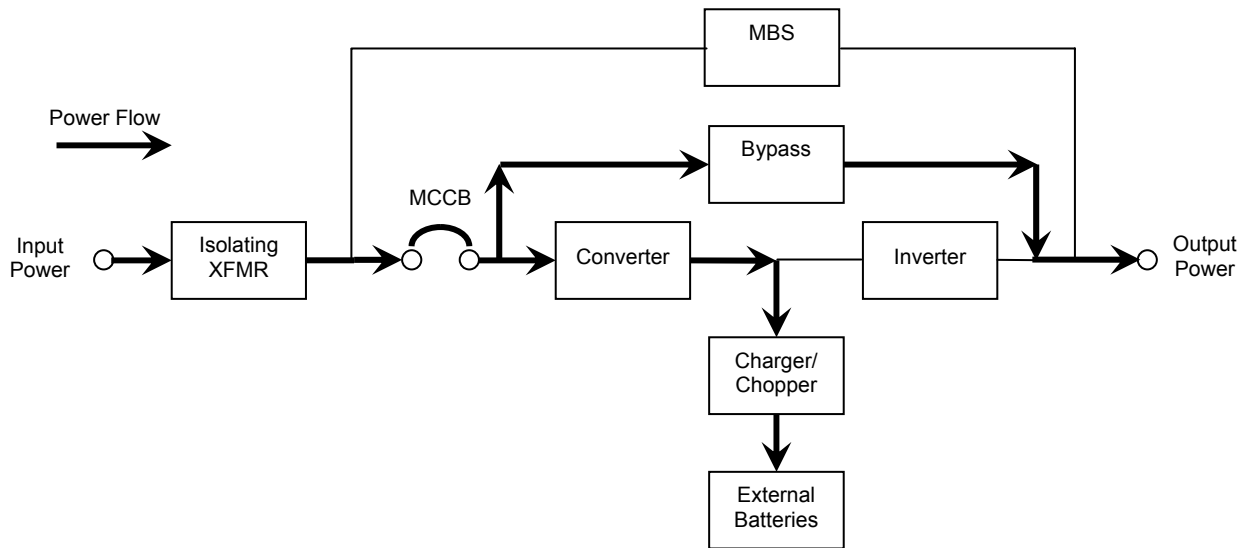

Power flow in Bypass mode

6.3 Bypass Mode for Optional Alternate Input Models

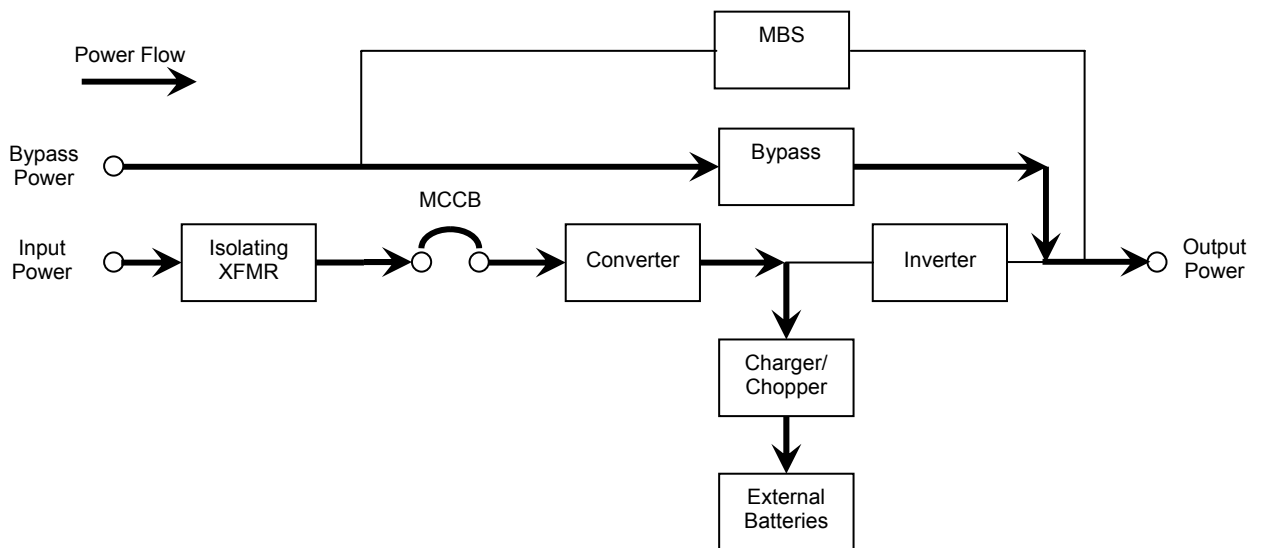

Power flow in Bypass mode for the Alternate Input Models

6.4 Battery Backup Mode

The following illustration shows power flow during the battery backup mode. When commercial AC power failures occur, the batteries instantly begin supplying DC voltage to the main inverter circuit. This circuit inverts (hence; Inverter) the DC power into AC power. The AC power is available at the output. This back-up process will continue until the battery voltage drops below a specific minimum level. When this occurs, the batteries will stop supplying power to the load. This minimum level is the rated minimum voltage (V_{min}).

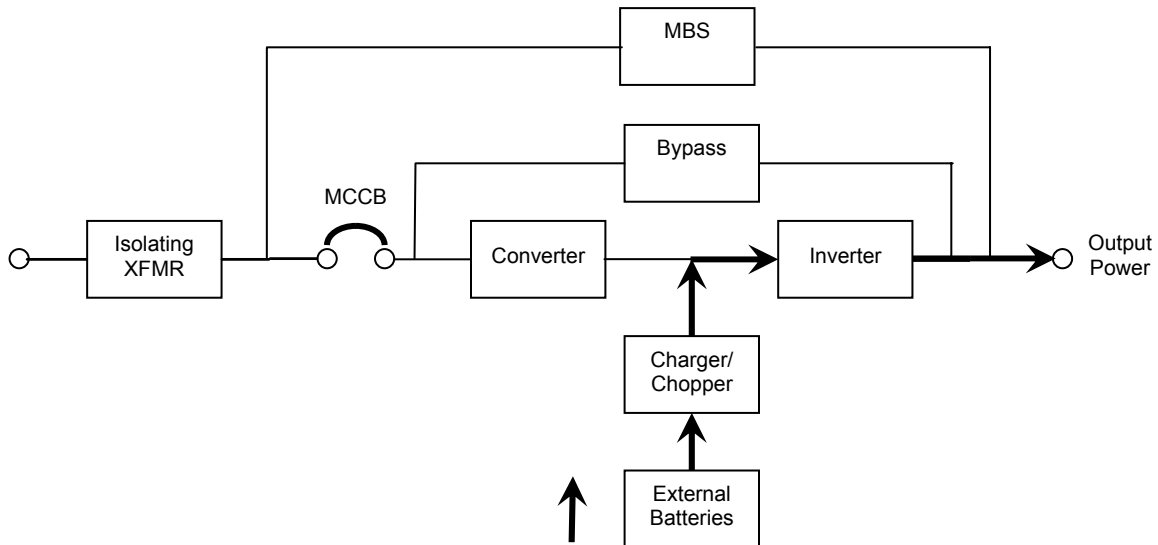

Power flow in battery backup mode

6.5 Battery Backup Time and Discharge Process

The UPS system, when used in conjunction with a TOSHIBA designed Battery System, is designed to provide several minutes of back-up time (Refer to the Battery System Manual for back-up times). These times are valid when the unit is operating under full load. When these models are operating at half load, the batteries can provide approximately 2 times the specified value. The exact length of these times will depend on the UPS model used, condition of the batteries, amount and type of load, temperature and other variables.



CAUTION

Contact TOSHIBA when using other than TOSHIBA designed Battery Systems to determine proper compliance. Using other systems could void Warranty and or Safety Certifications.

The following illustration graphically shows the battery discharge process at full load conditions.

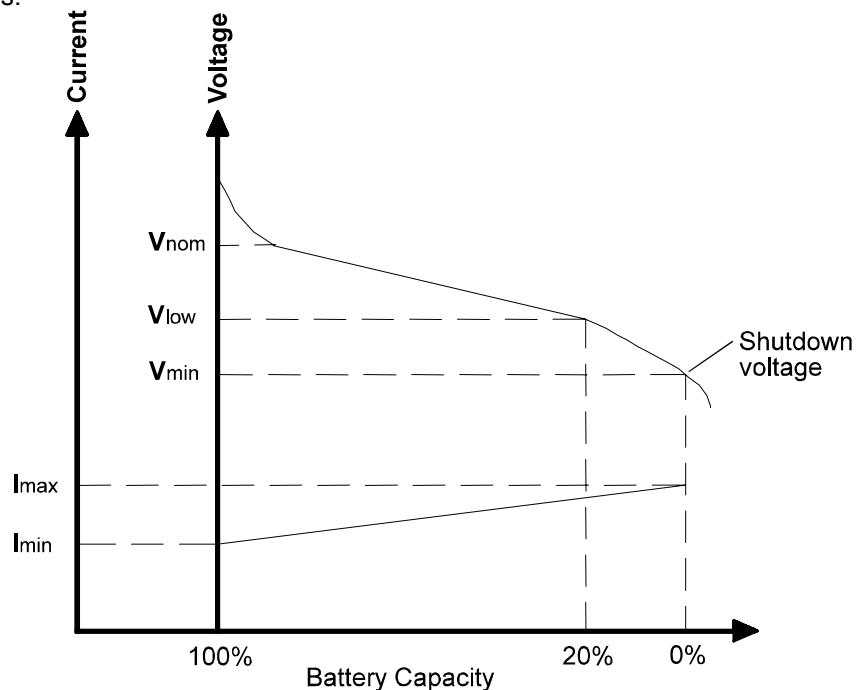

6.6 Battery Low Voltage Tolerances

Excessive discharge will cause the UPS battery voltage to drop below tolerable levels. The chart shown below lists the voltage level at which each UPS unit's low-voltage alarm will sound, and also at what level the low-voltage condition will cause the unit to automatically shut down.

| Models | 15/25/30/50 kVA |
|-----------------------|-----------------|
| Nominal Voltage | 288 VDC |
| Alarm Voltage | 252 VDC |
| Shutdown Voltage min. | 216 VDC |

6.7 Battery Recharging

The illustration below shows a graphical representation of the UPS battery recharge process after a full discharge.

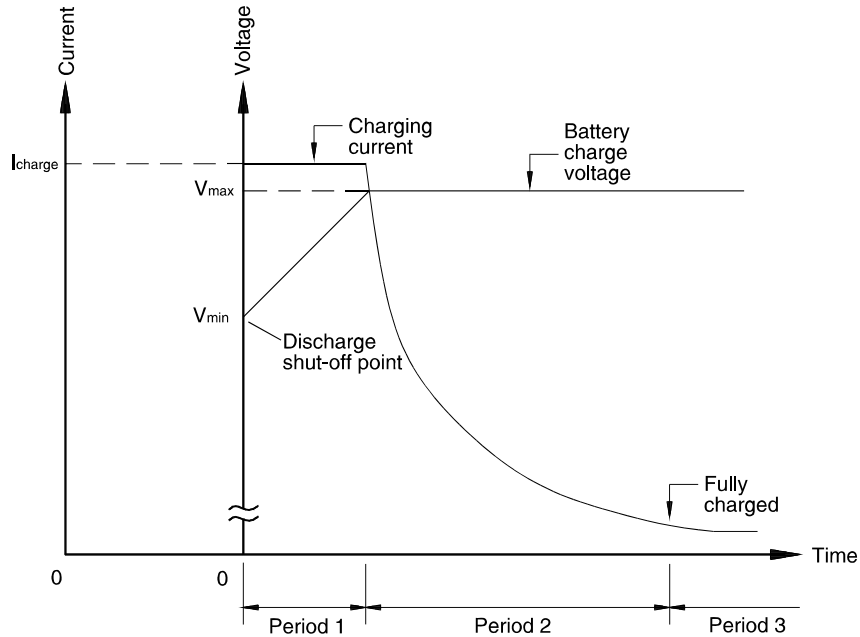

The recharge process usually consists of three steps. During the first step, the charging current is maintained at approximately 4.0 amperes for the 15/25/30 kVA with internal batteries, 10.0 amperes for the 15/25/30 kVA with internal transformer and approximately 11.5 amperes for all 50 kVA models. This current is the maximum value that can be used to charge the batteries (for minimal recharge time) while assuring safety and long battery life. In the second step, constant-voltage control starts and current gradually decreases as the batteries charge to their normal fully charged state. In the third step, a slight "trickle" current continues to flow into the batteries to keep them fully charged and "floating" at the normal DC Voltage level. A full recharge usually requires approximately 24-72 hours (90% recharge in 10 X discharge time) after a complete discharge.

The following chart shows the rated maximum and minimum battery voltages, and the charge current for each of the sizes while the unit is maintained in a 75 °F (24 °C) ambient.

Rated Battery Voltages

| Model | 15/25/30 kVA | | 50kVA | |
|-----------------|------------------|----------------------|------------------|----------------------|
| | Internal Battery | Internal Transformer | Internal Battery | Internal Transformer |
| V float | 324.0 VDC | 324 VDC | 324 VDC | |
| V min | 216 VDC | 216 VDC | 216 VDC | |
| I charge | 4.0 A | 10.0 A | 11.5 Amps | |

6.8 Front Panel Layout (All Units)

Refer to the following illustration for the entire UPS front panel operating procedures.

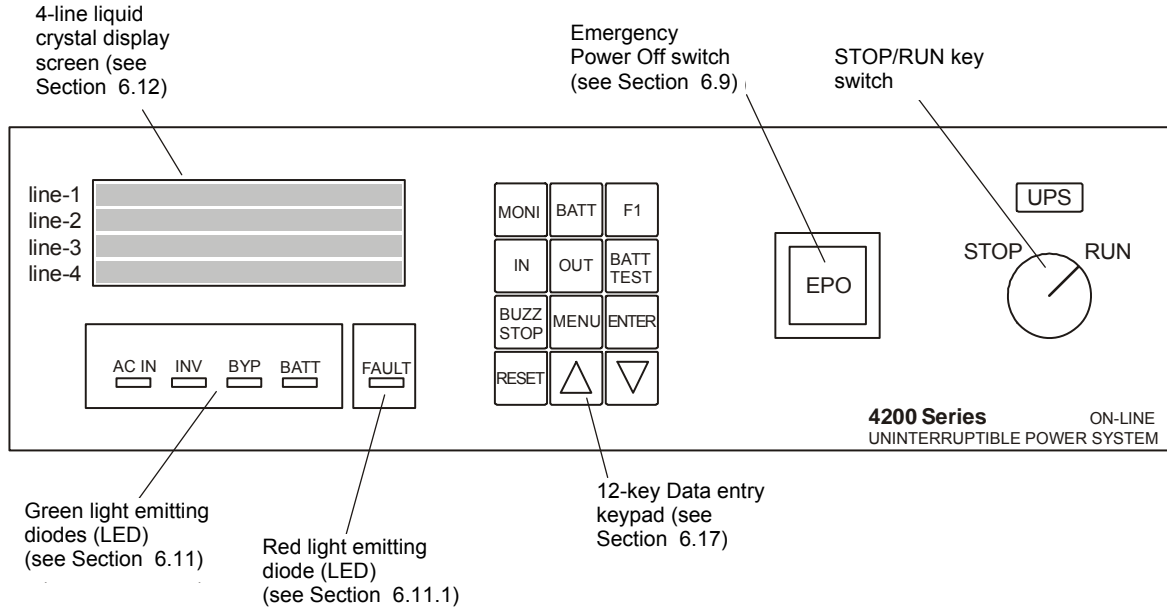

6.9 EPO (Emergency Power Off) Function

These units are equipped with terminals for receiving an EPO (Emergency Power Off) "closed contact" switch command from two locations: (1) a remote location and (2) from a front panel mounted EPO switch. This safety feature enables quick shutdown of the UPS AC output and battery circuits. Usually the EPO switch is installed in a central location that is easily accessible to personnel concerned with the operation of the UPS and the equipment connected to it. The EPO function is initiated by pressing the switch to the closed "shutdown" position. The effect of using the EPO switch is the same whether the UPS is in the AC Input Mode, Battery Backup Mode, or the Bypass Mode. See 'EMERGENCY OFF' screen. The following figure shows the UPS condition after application of the EPO switch. **Use the Start-up Procedure for restarting the unit.**

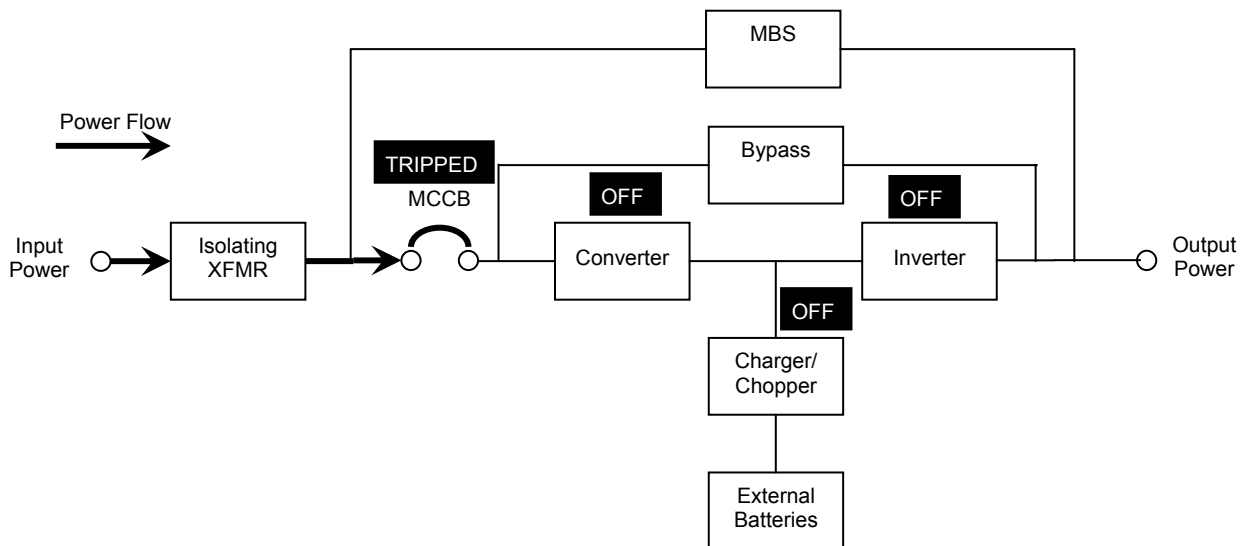

6.10 Audible Alarm Functions

Audible alarms will sound when the UPS is in the Battery Backup Mode, has a fault, is at the low battery voltage, or is in an overload condition. The following chart shows the audible alarm pattern duration for each condition. Time intervals are shown in seconds. The audible alarm can be silenced, by pressing "BUZZ STOP" on the keypad.

| Condition | Audible pattern |
|---------------------------------------------------------|-----------------|
| UPS in Battery Backup Mode (Battery Voltage 100-92%) | |
| UPS Low Battery (Battery Voltage < 92%) | |
| Overload | |
| Fault | |

6.11 LED (Light Emitting Diode) Functions

The following list describes the conditions necessary for each LED lamp to be "on."



On when the UPS has normal AC input power that is within tolerance. If there is an input power failure this LED is off. If there is no power failure and the input voltage is in an over-voltage condition, the AC IN LED will flicker on and off rapidly (0.4 sec on and 0.4 sec off). If there is no power failure and the input voltage is in an under-voltage condition the AC IN LED will be off.



On when the UPS inverter is operating.



On when the UPS is in the static bypass mode.



On when the UPS is in the battery-discharge mode. If the battery is low during a battery discharge, the BATT lamp will flicker on and off slowly (1.2 second on and 1.2 second off). The BATT LED will go off if the battery voltage reaches the shutdown level during the battery-discharge mode.



On when the UPS is experiencing a fault.

6.11.1 LED (Light Emitting Diode) System Status

The following chart shows the UPS system status that can be determined by decoding the "on" and "off" condition of the LED lamps. It should be used in conjunction with the LCD display and the audible alarms for total system monitoring.

| LED | | ON/OFF STATUS | | LED | | ON/OFF STATUS | |
|---------------------------------------------------------------|---------------|---------------|----------------------|---------------------------------------------------------------|----------------------|---------------|----------------------|
| Normal UPS Operation (UPS On-Line, no abnormal conditions) | | | | Output Shutdown (After EPO received (Emergency Power Off)) | | | |
| AC IN | ON | AC IN | OFF | INV | OFF | BYP | OFF |
| INV | ON | INV | OFF | BATT | OFF | FAULT | OFF |
| BYP | OFF | | | | | | |
| BATT | OFF | | | | | | |
| FAULT | OFF | | | | | | |
| Bypass Operation; UPS Fault | | | | Fatal Communication Error (Display to Control Interface) | | | |
| AC IN | ON | AC IN | ALL ON OR FLICKERING | INV | ALL ON OR FLICKERING | BYP | ALL ON OR FLICKERING |
| INV | OFF | INV | ALL ON OR FLICKERING | BATT | ALL ON OR FLICKERING | FAULT | ALL ON OR FLICKERING |
| BYP | ON | BYP | ALL ON OR FLICKERING | | | | |
| BATT | OFF | | | | | | |
| FAULT | ON | | | | | | |
| Battery Back-up; (Battery Voltage Low) | | | | | | | |
| AC IN | OFF | | | | | | |
| INV | ON | | | | | | |
| BYP | OFF | | | | | | |
| BATT | ON (Blinking) | | | | | | |
| FAULT | OFF | | | | | | |

6.12 LCD (Liquid Crystal Display) Functions

The LCD screen is a 4-line by 20-character wide display. The LCD display contains information about the operation of the UPS. It should be used in conjunction with the LED display and the audible alarms for total system monitoring. The LCD displays certain information only on specific lines of the display. The UPS operating mode and conditions determines the information shown. These messages are shown in the following line message charts.

6.12.1 Line-1 System Messages

Line-1 messages are based on the operating mode. The following chart shows all allowable Line-1 messages, which occur while starting up and while in main monitor (MONI) screen mode.

LINE-1 MESSAGES

| Display Message | Translation |
|-----------------------|------------------------------------------------------------------------------------------------------------------------------------------------------------------|
| - UPS START UP - | Displayed when UPS is in the start-up condition or display board is resetting. |
| - BYPASS OPERATION - | Displayed when the UPS is in Bypass Operation. |
| - UPS ON-LINE - | Displayed when the inverter is running, and no abnormality exists. |
| - BATTERY DISCHARGE - | Displayed during abnormal Utility occurrences; inverter is supplying power from batteries. (UPS shuts down after V (min.) is reached. |
| - OUTPUT SHUTDOWN - | Displayed during power failure if V (min.) is reached, an EPO is received, or after completion of Shutdown Sequence of the Inverter and Bypass is not available. |
| - BATTERY BACKUP - | Displayed during input power failure. |

6.12.2 Line-2 System Fault Messages

Line-2 fault messages are automatically displayed when a system fault is detected.

LINE-2 MESSAGES

| Display Message | Translation |
|-----------------|------------------------|
| DCOC | DC Over-current |
| DCUB | DC Unbalanced |
| DCOV | DC Over-voltage |
| OH | Overheat (internal) |
| OL | Output Overload |
| VOUV | Inverter Under-voltage |
| VOOV | Inverter Over-voltage |

6.12.3 Line-3 System Messages

Line-3 messages show load current information, and user selected instructions.

6.12.4 Line-4 System Messages

Line-4 messages reflect the UPS operating conditions. Warning messages will be displayed when an abnormal operating condition occurs. The following chart shows the allowable Line-4 messages.

LINE-4 MESSAGES

| Displayed Message | Translation |
|-----------------------------------|--------------------------------------------------------------------------------------------------------------------------------------|
| PHEI | Displayed when Input Phase rotation has been wired in a counter-clockwise rotation. |
| I/O NOT SYNCHRONIZE | Displayed when input and output frequencies are not synchronized. (Abnormal) |
| * AUTOTRANSFER * | Displayed when Auto-transfer to Bypass is active (i.e. current limit reached). (Abnormal) |
| * LOW BATTERY * | Displayed when battery voltage is low (abnormal) or the UPS batteries have failed self-diagnostic test. (Abnormal) |
| * UPS OL: REDUCE LOAD * | Displayed when UPS has tripped due to an overload condition. (Abnormal) |
| * DCOC * | Displayed when the UPS has an internal failure. (Abnormal) |
| * DCOV * | Displayed when the UPS has an internal DC bus over-voltage. (Abnormal) |
| * DCUB * | Displayed when the UPS has an internal DC bus unbalance referenced to Neutral. (Abnormal) |
| * OL * | Displayed when UPS has tripped due to an overload condition. (Abnormal) |
| * FUSE * | Displayed when an internal transistor fuse opens. |
| * INOV * | Displayed when inverter output over-voltage has occurred. (Abnormal) |
| * INUV * | Displayed when inverter output under-voltage has occurred. (Abnormal) |
| * BATT. OH *OR MCCB-B OPEN | Displayed when the optional battery over-temp sensor has activated, or if the external battery disconnect is open. (Verify TB3-5, 6) |
| * MM/DD/YY (DAY) HH:MM * | Displayed when none of the above abnormal conditions are present. (Normal) |
| * TRANSFER INHIBITED * | Displayed when key switch position is changed and frequency is not synchronized. (Abnormal) |
| * ENTER FOR DETAILS * | Displayed when a Fault or Faults have occurred. (Abnormal) |

Note:

- 1) Line-4 will be blank when the BATT key is pressed during Battery Backup Mode with normal battery voltage.
- 2) The # symbol signifies numerical values or other information supplied by the UPS.

6.13 Initial Battery Charge

The UPS Battery System must be charged before it is used for the first time or when the unit has not been used (AC power source removed) for more than 10 days. Use the following procedure to recharge the UPS Battery System:

- 1) Switch on power at the UPS input distribution panel, and battery disconnects.
- 2) Move the UPS MCCB (Circuit Breaker 1) power switch on the inner front panel to "on." The UPS battery charging circuit is now activated. The AC IN lamp will be "on." The LCD screen should display the following message:

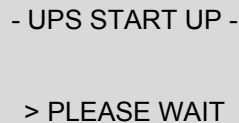

```
- UPS START UP -  
  
> PLEASE WAIT
```

- 3) With the key switch in the STOP position, the AC IN and the BYP lamp will be "on" and the LCD screen should display the following message:

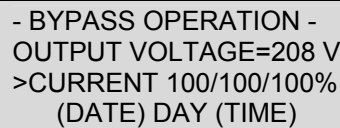

```
- BYPASS OPERATION -  
OUTPUT VOLTAGE=208 V  
>CURRENT 100/100/100%  
(DATE) DAY (TIME)
```

- 4) Turn the Key Switch to "RUN" and the UPS automatically performs a controlled system battery test. (Note: The Automatic Battery Test is performed only when the software is enabled for this function. The standard default is set to disable.)

(Allow 24-72 hours for the batteries to fully charge).

When automatic battery test fails and the "LOW BATTERY" message is displayed use the following procedure:

- 1) Turn the key switch to STOP.
- 2) Allow 24-72 hours for the batteries to charge and then move the Circuit Breaker to "off."
- 3) Repeat Initial Battery Charge procedure. (A failure indicates battery replacement may be necessary).

6.14 Start-up Procedure

The UPS batteries must be charged before the UPS is used for the first time or if the unit has not been used (AC power source removed) for more than 10 days. If the batteries are charged then use the following start-up procedure:

- 1) Verify that all power switches are off, and that the "STOP/RUN" Switch on the UPS is in the "STOP" position.
- 2) Switch on the power at the Customer Provided UPS input distribution panel.
- 3) Move the UPS Circuit Breakers to "on." The AC IN lamp will be "on." The LCD screen should display the following message:

```
- UPS START UP -  
  
> PLEASE WAIT
```

With the key switch in the "STOP" position, both the AC IN and the BYP lamp will be "on" and the LCD screen should display the following message:

```
- BYPASS OPERATION -  
OUTPUT VOLTAGE=208 V  
>CURRENT 100/80/90%  
DATE (DAY) TIME
```

The UPS battery charging circuit is now activated. Move the "STOP/RUN" key switch to the "RUN" position. The inverter will then start and the UPS will transfer to the Normal Operating Mode. Both the AC IN and the INV lamp will be "on." The following system message is an example of the main MONI (monitor) screen for standard operation:

```
- UPS ON-LINE -  
OUTPUT VOLTAGE=208 V  
>CURRENT 100/80/90%  
DATE (DAY) TIME
```

If a fault occurs during start-up, the red FAULT lamp will be "on" and the LCD screen will display a FAULT(s) DETECTED at start-up message such as the following:

```
UPS FAULT (BYPASS ON)  
(DESCRIPTION)  
PRESS DOWN TO DETAIL  
> ENTER FOR DETAILS
```

Refer to the "Line-2 System Fault Messages" section for details.

6.15 Shutdown Procedure

When turning off the UPS, the following shutdown procedure should be used:

Move the "STOP/RUN" key switch, located on the front panel, to "STOP." Operation of the inverter halts. Output power is now provided to the load through the unit's Bypass circuit.

While in this state of operation; if a power failure occurs in the commercial power source, the UPS will lose power. Power to the critical load device will be interrupted.

The battery charging circuit and chopper circuit remains active.



DANGER

Do not touch the UPS terminals even though the operation switch has been moved to the STOP position. The UPS may be supplying power through the Bypass circuit.

The green AC IN lamp is "on" and the green BYP lamp is "on." The LCD screen shows the following message:

```
- BYPASS OPERATION
  OUTPUT VOLTAGE=208
                V
  >CURRENT 100/100/100%
  DATE (DAY) TIME
```

Move the Circuit Breaker to the "off" position. **Power is removed from the UPS and to any attached loads.** All lamps are "off" and the LCD screen shows the following message as long as sufficient power remains to display it:

```
- OUTPUT SHUT DOWN -
  OUTPUT VOLTAGE= 0 V
  CURRENT=LOW/LOW/LOW%
```

When the EPO (Emergency Power Off) switch, located on the front panel (or from a remote located EPO switch) is pushed, the Circuit Breaker is tripped and power is removed from the UPS and to any attached loads. All LED lamps are "off" and the LCD screen will display the following message:

```
- OUTPUT SHUT DOWN -
  OUTPUT VOLTAGE= 0 V
  CURRENT=LOW/LOW/LOW%
```

6.16 Maintenance Bypass Procedure

When operating the Maintenance Bypass, the following operation procedure should be used:



WARNING

Failure to adhere to the following instructions could result in damage to your equipment and/or you risk removal of power to any equipment attached to the UPS.

6.16.1 From UPS to Maintenance Bypass

- 1) Move the "STOP/RUN" key switch, located on the front panel, to "STOP." Operation of the UPS inverter stops. Output power is now provided to the load through the Bypass circuit. **While in this mode, if a power failure occurs on the commercial power source, the UPS will lose power. Power to the critical load device will be interrupted.** The battery charging circuit and chopper circuit remains active.
- 2) Verify that step one above is followed, and that the Bypass light indicator on the front panel is lit.
- 3) Locate the Maintenance Bypass Rotary Switch (middle of inner front panel of the UPS); slowly rotate the Cam Switch clockwise until "BYPASS MODE" Position is reached.
- 4) Turn off MCCB breaker labeled "MAIN POWER SWITCH."

The unit is now in the Maintenance Bypass mode and may be serviced. For units with internal transformers, the transformers are still energized.



6.16.2 From Maintenance Bypass to UPS



- 1) Verify that the "STOP/RUN" switch is in the "**STOP**" position. Turn on MCCB "MAIN POWER SWITCH."
- 2) Wait until the output fans turn on (this is a good indication that the unit is in the Bypass mode), and that the Bypass indicator light on the front panel is lit.
- 3) For units with an external battery cabinet, turn on MCCB "BATTERY CABINET."
- 4) Locate the Maintenance Bypass Switch (middle of inner front panel of the UPS) slowly rotate the Cam Switch counter-clockwise until "UPS MODE" Position is reached.
- 5) Rotate the "STOP/RUN" switch to the "**RUN**" position.
- 6) Verify that the Inverter indicator light on the front panel is lit.

The unit is now back On-Line and supplying conditioned power to the load.

6.17 Keypad Overview

The following illustrates the 12-key data entry pad with each key functionally labeled.

| | | |
|------------------|-----------------------------------------------------------------------------------|-----------------------------------------------------------------------------------|
| MONI | BATT | F1 |
| IN | OUT | BATT TEST |
| BUZZ STOP | MENU | ENTER |
| RESET |  |  |

| | |
|-------------------------------------------------------------------------------------|---------------------------------------------------------------------------|
| MONI | Press to display system-monitoring screens. |
| BATT | Press to display UPS battery conditions. |
| F1 | Press to change settings of various menus. |
| IN | Press to display UPS input conditions. |
| OUT | Press to display UPS output conditions. |
| BATT TEST | Press to execute On-Line Battery test. |
| BUZZ STOP | Press to stop the audible alert buzzer. |
| MENU | Press to display the main user-selection menu. |
| ENTER | Press to confirm user-selected command or action. |
| RESET | Press to reset UPS panel's message-display area. |
|  | Press to forward through display data values or to forward through menus. |
|  | Press to reverse through display data values or to reverse through menus. |

6.18 Key Functions

6.18.1 MONI

After the UPS has been successfully started, the system will be in the normal 'AC Input Mode' of operation. The LCD screen will automatically display the main MONI (monitor) function. If the MONI key is pressed at this time the screen output will not change. The MONI function automatically monitors the entire UPS system. The LCD screen will automatically switch "off" after a period of keypad inactivity and switch "on" if any key is pressed. It will switch "on" automatically during battery discharge or if an abnormality develops in the system (see "Settings for LCD Display Duration"). All system 'line' messages will be displayed from MONI mode when abnormal operating problems are detected. If AC input power is available and the UPS is operating normally, the following system message is displayed:

```
- UPS ON-LINE -  
OUTPUT VOLTAGE= 208 V  
CURRENT=100/100/99%  
DATE (DAY) TIME
```

If an AC input power failure occurs, and no abnormal operating conditions are present, the UPS switches to standard 'Battery Backup Mode'. The following system message is displayed:

```
- BATTERY BACKUP -  
OUTPUT VOLTAGE = 208 V  
CURRENT=100/100/99%  
DATE (DAY) TIME
```

6.18.2 IN

When the IN key is pressed during normal 'AC Input Mode' of operation, the LCD screen displays details about the unit's input voltage. The following system message is displayed:

```
- UPS ON-LINE -  
INPUT      Vab = 96%  
VOLTAGE    Vbc = 96%  
           Vca = 96%
```

The Bypass Input Voltages, Frequencies / Sync Mode, and Converter Current can be monitored by pressing the "UP/DOWN" keys.

6.18.3 OUT

When the OUT key is pressed during normal 'AC Input Mode' of operation, the LCD screen displays details about the output voltage, current, and frequency. The following system message is displayed:

```
- UPS ON-LINE -  
OUTPUT     Ia = 101%  
CURRENT    Ib = 100%  
           Ic = 100%
```

The Output Line Voltages (phase-neutral, and phase to phase), Frequencies / Sync Mode, Inverter Output Power, and Power factor can be monitored by pressing the "up/down" keys.

6.18.4 BATT Key

When the BATT key is pressed during normal 'AC Input Mode' of operation, the LCD screen displays details about the battery capacity. The following system message is displayed:

```
- UPS ON-LINE -  
BATTERY VOLTAGE=324V  
CHARGE CURR.=0%
```

If an AC input power failure occurs, and no abnormal operating conditions are present, the UPS will switch to standard 'Battery Backup Mode'. The following system message is displayed when the BATT key is pressed:

```
- BATTERY BACKUP –  
BATTERY VOLTAGE=324V  
DISCHARGE CURR. =76%
```

6.18.5 MENU, F1, ENTER, UP, & DOWN Keys

When the MENU key is pressed during normal 'AC Input Mode' of operation, a menu of user adjustable data screens are available. Press 'up' arrow key to scroll up through the available data screens. Press 'down' arrow key to scroll down through the available data screens. Pressing the F1 key changes to the adjustment screen for that menu item. Press 'up' arrow to move display to previously available item. Press 'down' arrow to move display to next available item. From the adjustment screen, if the MENU key is pressed any changes are discarded and the display returns to the regular menu screen with the previous data values shown. If the "ENTER" key is pressed from the adjustment screen, the changes are saved. After pressing the "ENTER" key, the display screen will return to the regular menu screen with the new data values shown (see "Menu Data Screens").

6.18.6 BATT TEST Key

When the BATT TEST key is pressed during normal 'AC Input Mode' of operation, the LCD screen displays details about the battery back-up capacity. The following system message is displayed:

```
- BATTERY TEST –  
BATTERY VOLTAGE=324V  
  
> F1+ENTER TO BEGIN
```

Press the F1+ ENTER keys at the same time to begin the battery test and to display the following screen while batteries are tested:

```
- BATTERY TEST -  
BATTERY VOLTAGE=324V  
## MINS ## SECS  
> PLEASE WAIT
```

When the battery test is completed, the previous operation will be resumed and the main system MONI screen will be displayed. If the battery test detects a low DC battery voltage, then the message screen will display:

- UPS ON-LINE -
OUTPUT VOLTAGE=208 V
CURRENT=38/55/48%
* LOW BATTERY *

If the battery test passes then the following screen message will be displayed:

- UPS ON-LINE -
OUTPUT VOLTAGE=208 V
CURRENT=38/55/48%
DATE (DAY) TIME

If the inverter is not operating when the BATT TEST key is press then the function will be inhibited and the following screen message will be displayed:

- BATTERY TEST -
BATTERY VOLTAGE=324V

BATT. TEST INHIBITED

NOTE:

After start-up, the battery test function is inhibited for 20-min. (only one battery test can be done approximately every 20-min.).

6.18.7 BUZZ STOP Key

The "BUZZ STOP" key has no effect on the LCD screen display. However if the UPS alarm buzzer is on, pressing this key will silence it. If the alarm buzzer is not on, pressing this key has no effect.

6.18.8 RESET Key

The RESET key function is used to 'Reset' the LCD display board software should a system lock-up occur. The reset does not reset the variables in the memory. *Use of the RESET function is very important when a fatal communication error has occurred.* Press and hold the RESET key for a period of at least five seconds to reset the display software. The 'display board' to 'main board' interface will begin a new communication sequence. If a communication response is not received by the 'display board' from the 'main board' within 15 seconds, a fatal time-out occurs and the following system message displays:

- DISPLAY ERROR -
MAIN COMM. ERROR

PRESS & HOLD RESET KEY

If the 'Reset' function is successful then the display will begin from the 'Start-up screen' and then change to the 'main monitor' screen.

6.19 Menu Data Screens

6.19.1 Settings for Calendar and Clock

Press the MENU key to access the menu data screens and press the 'down' arrow key to scroll to the present date and time adjustment screen:

```
CALENDER / CLOCK
DATE (DAY) TIME
>*F1: DATA SET MODE
>Δ/∇ PRV/NEXT SCREEN
```

Press the F1 key to display the following active adjustment screen:

```
CALENDER / CLOCK
DATE (DAY) TIME
> Δ/∇ : UP/DOWN
>ENTER:NEXT DATA
```

Press the "up/down" arrows to increment or decrement the character(s) above the flashing cursor.

Press the ENTER key to advance the cursor.

6.19.2 Adjusting the Buzzer Volume

Press the MENU key to access the menu data screens and press the 'down' arrow key to scroll to the present buzzer volume adjustment screen display:

```
BUZZER VOLUME ADJUST
<LOUD> MEDIUM SOFT
>*F1: DATA SET MODE
>Δ/∇:PRV/NEXT SCREEN
```

Press the F1 key to display the following active adjustment screen:

```
BUZZER VOLUME ADJUST
<LOUD> MEDIUM SOFT
>Δ/∇: CHANGE DATA
>ENTER:ACCEPT CHANGE
```

Press the 'up' or 'down' arrow key to move the marker between the three buzzer volume levels. Press ENTER key to confirm the change or press MENU key to discard any changes and return to the menu data screen.

6.19.3 Settings for Display Duration

The LCD display is designed to automatically switch off after a user-designated period of inactivity. When setting this feature, press the MENU key to access the menu data screens and press the 'down' arrow key to scroll to the LCD-Idle Mode Select screen display:

```
DISPLAY DURATION SET
<3 MIN>      30 MIN
>F1: DATA SET MODE
>Δ/∇:PRV/NEXT SCREEN
```

Press the F1 key to display the LCD-Idle mode setting adjustment screen:

```
DISPLAY DURATION SET
<3 MIN>      30 MIN
>Δ/∇: CHANGE DATA
>ENTER:ACCEPT CHANGE
```

Press the 'up' or 'down' arrow key to move the marker between the two available idle mode times. Press the ENTER key to save the change or press the MENU key to exit to the main menu and discard the change.

Note: If any of the following conditions occur, the LCD-Idle Mode will be inhibited and the LCD will remain on continuously:

- 1) The UPS has received an EPO command.
- 2) The UPS is in Battery-Discharge Mode.
- 3) A fault has been detected in the main unit.
- 4) The UPS is in an overload condition.

6.19.4 Run Switch Select

Press the MENU key to access the menu data screens and press the 'down' arrow key to scroll to the "Run Switch Select" setting screen display:

```
RUN SWITCH SELECT
<LOCAL>  REMOTE
>*F1: DATA SET MODE
>Δ/∇: PRV/NEXT SCREEN
```

Press the F1 key to display the following active adjustment screen:

```
RUN SWITCH SELECT
<LOCAL>  REMOTE
>Δ/∇: CHANGE DATA
>ENTER:ACCEPT CHANGE
```

Press the 'up' or 'down' arrow key to move the marker between the two "RUN SWITCH" selections Press the ENTER key to save the change or press the MENU key to exit to the main menu and discard the change. (Must have Remote Control option.)

6.19.5 Serial Com Station Address

Press the MENU key to access the menu data screens and press the 'down' arrow key to scroll to the "Serial Comm Station Address" setting screen display:

```
SER COM STATION ADDR
STATION ADDRESS: 31H
>*F1: DATA SET MODE
> Δ/∇: PRV/NEXT SCREEN
```

Press the F1 key to display the following active adjustment screen:

```
SER COM STATION ADDR
STATION ADDRESS: 31H
>Δ/∇: CHANGE DATA
>ENTER: ACCEPT CHANGE
```

6.19.6 Output Voltage Adjustment

When the MENU key is pressed and held 3-4 seconds during normal 'AC Input Mode' of operation, the LCD screen displays the output voltage on the present output voltage adjust screen:

```
OUTPUT VOLT. ADJUST
OUTPUT VOLTAGE.=###%
>F1:DATA SET MODE
>Δ/∇:PREV/NEXT SCREEN
```

Press the F1 key to display the following active adjustment screen:

```
OUTPUT VOLT. ADJUST
REFERENCE ADJUST: ##
>Δ/∇:CHANGE DATA
>ENTER: ACCEPT CHANGE
```

The locations marked **##** will show the numerical value of the allowable voltage adjustment parameter values. Press the 'up' and 'down' arrow keys to adjust the setting from between ± 5 volts. This will cause the unit's output voltage to adjust to within $\pm 2\%$ of its nominal value.

If the inverter is not running, and the output voltage cannot be adjusted; the following message will be displayed:

```
OUTPUT VOLT. ADJUST
ADJUST PROHIBITED
DATA CANNOT CHANGE
>Δ/∇:PRV/NEXT SCREEN
```

Pressing the F1 key will have no effect on this display screen

6.19.7 Equalize Charge Mode Select

Contact Toshiba Customer Support toll free at 1-877-867-8773 before using this option.

DAMAGE to the battery system may occur if this option is used improperly.

6.19.8 Reset to Default Settings

Press the MENU key to access the menu data screens and press the 'down' arrow key to scroll to the original factory 'default settings' adjustment screen display:

```
MENU DATA RESET
DATA INITIALIZATION
>F1: TO ACCESS RESET
>Δ/∇:PRV/NEXT SCREEN
```

Press the F1 key to display the following active adjustment screen:

```
MENU DATA RESET
DATA INITIALIZATION
> MENU: NO DATA RESET
>ENTER: ACCEPT CHANGE
```

When the ENTER key is pressed the following factory defaults are reset:

- 1) Resets the voltage-reference setting to +0
- 2) Resets the buzzer volume to 'loud'
- 3) Resets the serial station address to 31h
- 4) Resets the idle mode to 3 minutes

Press the MENU key to abandon the operation and return to the menu data screen.

6.20 Overload Operation

When the UPS is operating and an overload condition is first detected, the following "Overload Warning" screen is displayed.

```
- UPS ON-LINE -
OUTPUT VOLTAGE= ###V
OUTPUT CURRENT= ###%
* UPS OL: REDUCE LOAD *
```

After a period of time, if the overload is still not reduced and the STOP/RUN key switch is in the RUN position, the UPS will automatically transfer to Bypass. If the overload condition is still present, the following screen will be displayed:

```
- BYPASS OPERATION -
OUTPUT VOLTAGE=208
CURRENT= 114/116/114%
* UPS OL: REDUCE LOAD *
```

If the STOP/RUN key switch is in the STOP position; the UPS is in the Bypass Mode and, if the overload condition is still present, the following screen will be displayed:

```
- BYPASS OPERATION -
OUTPUT VOLTAGE=208
CURRENT= 114/116/114%
* UPS OL: REDUCE LOAD *
```

After the load is reduced, if the STOP/RUN key switch is in the RUN position, the UPS will automatically return to 'Inverter Operation' after a period of time. During this wait, the following screen will be displayed:

```
- BYPASS OPERATION -  
OUTPUT VOLTAGE=208 V  
CURRENT= 100/100/100  
>PLEASE WAIT
```

Or if the UPS is waiting and the STOP/RUN key switch is switched to the STOP position while the UPS is waiting, the following screen will be displayed:

```
- BYPASS OPERATION -  
OUTPUT VOLTAGE=208 V  
CURRENT= 100/100/100  
>PLEASE WAIT
```

If the STOP/RUN key switch remains in the STOP position when the UPS's 'wait' period is complete, then the following screen will be displayed:

```
- BYPASS OPERATION -  
OUTPUT VOLATAGE=###V  
CURRENT=100\100\100%  
DATE (DAY) TIME
```

If the STOP/RUN key switch remains in the RUN position when the UPS's 'wait' period is complete, then the following screen will be displayed:

```
- UPS ON-LINE -  
OUTPUT VOLTAGE= 208 V  
CURRENT=100/100/99%  
DATE (DAY) TIME
```

6.21 Backup History and Fault History

Pressing the MONI and F1 keys simultaneously, for a few seconds will cause the Battery Discharge Count screen to be displayed.

```
BATT DISCHARGE COUNT  
# TIMES  
> F1: FOR DETAILS  
>Δ/∇: TO SCROLL
```

Press the F1 key to display the record relating to the first discharge event.

```
BACKUP HISTORY ( 1)  
#MIN##SEC VB=324V  
BT *PF OL  
>Δ/∇: EXIT F1: NEXT
```

TOSHIBA

Press the F1 key again to display the record relating to each subsequent discharge event.

```
BACKUP HISTORY ( #)
#MIN##SEC VB=324V
BT *PF OL
>Δ/∇: EXIT      F1: NEXT
```

Press the 'up' or 'down' arrow keys to return to the Battery Discharge Count screen.

```
BATT DISCHARGE COUNT
# TIMES
> F1: FOR DETAILS
>Δ/∇: TO SCROLL
```

Press the 'up' or 'down' arrow keys to display the Fault Count screen.

```
TOTAL FAULT COUNT
## TIMES
> F1: FOR DETAILS
>Δ/∇: TO SCROLL
```

Press the F1 key to display the record relating to the first fault.

```
FAULT HISTORY ( 1)
Date Time
fault code
>Δ/∇: EXIT      F1: NEXT
```

Press the F1 key again to display the record relating to each subsequent fault.

```
FAULT HISTORY ( #)
Date Time
fault code
>Δ/∇: EXIT      F1: NEXT
```

Press the 'up' or 'down' arrow keys to return to the Fault Count screen.

```
TOTAL FAULT COUNT
## TIMES
> F1: FOR DETAILS
>Δ/∇: TO SCROLL
```

7.0 UPS Protection System

7.1 System Protection Features

The preceding one-line schematic illustrates the electrical locations of the protection devices on all UPS models.

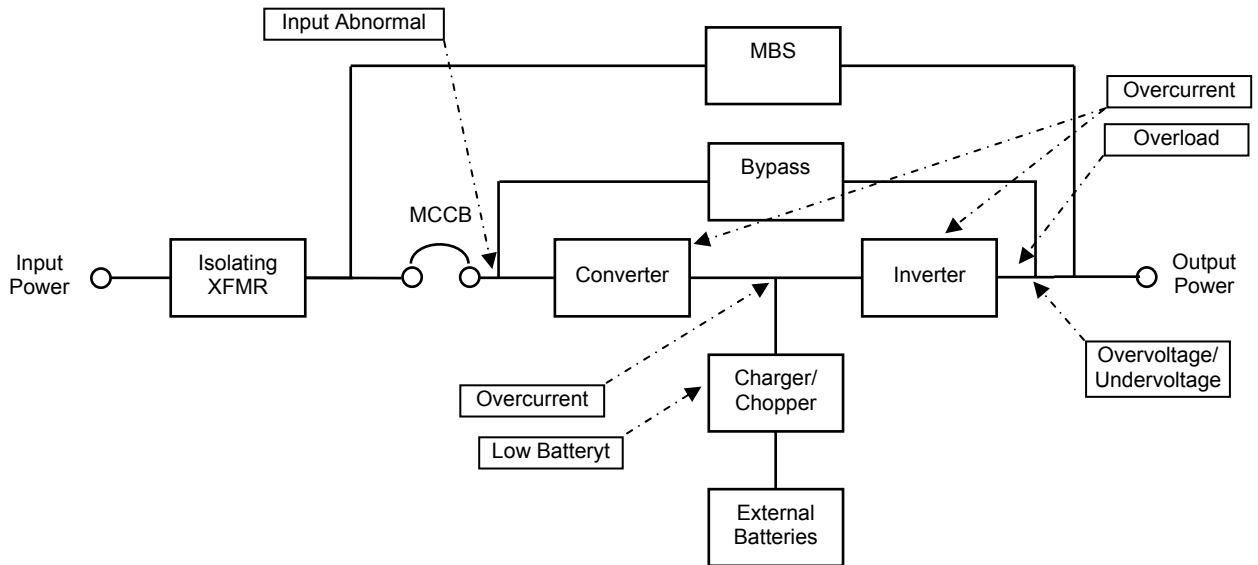

7.2 System Protection Functions

The following chart shows the built-in UPS fault protection functions on all models.

Built-in UPS Fault Protection Functions

| Protection Item | Inverter Over-voltage (IVOV) | Inverter Under-voltage (IVUV) | UPS Overload |
|-----------------------------------|------------------------------------------------|-------------------------------|---------------------------------------------------------------------------------------------------------------------|
| LCD Message | INVERTER OVERVOLTAGE | INVERTER UNDERVOLTAGE | OUTPUT OVERLOAD |
| Cause | Control Malfunction; Feedback Error | | Overload or short circuit at the load. |
| Operation Mode after Fault | Bypass Operation; Chopper and Inverter Stopped | | Inverter Overload: Transfer to bypass; Inverter stopped. Bypass Overload: Inverter, Chopper, and Bypass stopped. |
| Audible Alarm | Yes: See Audible Alarm Functions | | |
| Visible Alarm | Red Fault Lamp "on" | | Inverter OL: No Fault Lamp Bypass OL: Fault Lamp "on" |
| Relay Contact Alarm | Fault Relay closed; Bypass Relay closed | | Inverter OL: Bypass Relay closed Bypass OL: Bypass Relay open and Fault relay closed |
| Auto-Re-transfer | No | | Inverter OL: Yes, if bypass ok Bypass OL: No |

| Protection Item | Low Battery Voltage (Level-1) | Low Battery Voltage (Level-2) | Inverter Output Current Limit |
|-----------------------------------|----------------------------------|--------------------------------|--------------------------------------------------------------|
| LCD Message | Line-4 will read "BATTERY LOW" | DC UNDERVOLTAGE | OUTPUT OVERLOAD |
| Cause | Battery Discharge | Battery Shutdown Level reached | Load Inrush current |
| Operation Mode after Fault | Battery Discharge | Shutdown: No Output | If Bypass ok, transfer to bypass; if not, current-limit mode |
| Audible Alarm | Yes: See Audible Alarm Functions | | |
| Visible Alarm | Battery Lamp Flickers | NO | NO |
| Relay Contact Alarm | Low Battery Relay closed | Bypass Relay closed | |
| Auto-Re-transfer | No | | Yes, if bypass ok |

| Protection Item | Memory error (EERR) | Internal overheat (OH) | DC circuit overvoltage (DCOV) | DC circuit overcurrent (DCOC) |
|-----------------------------------|-----------------------------------------|----------------------------------------------------|-------------------------------|-------------------------------|
| LCD Message | MAIN EEPROM ERROR | OVERHEAT; INTERNAL | DC OVERVOLTAGE | DC OVERCURRENT |
| Cause | Control board chip error | Fan failure; high ambient | Chopper malfunction | Inverter / chopper fault |
| Operation Mode after Fault | Start is inhibited | Bypass operation; chopper and inverter are stopped | | |
| Audible Alarm | Yes; continuous buzzer | | | |
| Visible Alarm | RED fault lamp "ON" | | | |
| Relay Contact Alarm | Fault relay closed; bypass relay closed | | | |
| Auto-Retransfer | NO | | | |

8.0 Start-up/Scheduled Maintenance/Part Replacement

8.1 Start-up

The startup of the UPS equipment is broken up in several steps. These steps are as follows:

1. Initial Condition: This is where the service technician checks the unit for physical damage and verifies the installation of the UPS (electrically).
2. Static Checks: This step verifies the proper settings within the UPS logic.
3. Wiring Check: The wiring to (power cables) and from (control wires) the battery cabinet.
4. Main Voltage Check: The input voltages are checked to verify they are within the range.
5. Energizing the UPS: This step begins the internal self-checks within the processor logic.
6. Output Voltage Check: The output voltages are checked to verify they are within range.
7. EPO (Emergency Power Off): The EPO is operated to verify its operation in case of an emergency.
8. Load Testing: Performed if load is available.
9. Generator Testing: Performed if Generator is available.
10. Internal/External Maintenance Bypass: This verifies the proper operation of the Maintenance Bypass.

8.2 Preventive Maintenance

The TOSHIBA 4200FA Uninterruptible Power Systems have been designed to provide no years of trouble-free operation requiring a minimum of preventive maintenance.

The best preventive measure that the UPS user can take is to keep the area around the unit, particularly the air inlet vents, clean and free of moisture and dust accumulations. Schedule authorized TOSHIBA service centers to perform an internal parts inspection semi-annually.



CAUTION

Before performing any maintenance the technician should be familiar with and follow the important safety instructions within this manual.



WARNING

Proper maintenance of the battery system of this unit by a qualified service technician is essential to the safety and reliability of your UPS system. Schedule authorized TOSHIBA service centers to perform internal parts inspections semi-annually.

8.3 Parts Replacement

The following list shows intervals for periodic maintenance and replacement of certain UPS parts.

- 1) Batteries: VRLA (Valve Regulated Lead Acid) batteries do not require the adding of water or electrolyte. The charging voltage, temperature, performance and connection resistance must be monitored periodically. Necessary corrective maintenance must be made in order to assure the UPS supplies safe reliable power. These items affect the life of batteries, so replacement should be once every 3 to 5 years as a minimum. All of the batteries must be replaced at the same time to eliminate the possibility of multiple failures due to resistances of the batteries.
 - 8) **Recommended Quarterly Maintenance**
 - A. Visual Checks
 - 1) Leakage
 - 2) Corrosion on positive terminal
 - B. Check battery temperature at the negative terminal
 - C. Measure and record the system float charging voltage.
 - D. Measure and record the individual unit's float charging voltage.
 - 9) **Recommended Semi-Annual maintenance**
 - A. Repeat the quarterly checks.
 - B. Perform impedance checks on the individual batteries.
 - C. Optionally test for the purpose of trending the battery over time.
 - D. Re-torque all inter-battery connecting hardware (if applicable).
- 2) Aluminum electrolytic capacitors: Replace once every 5 years.
- 3) Fuses: Replace once every 7 years.
- 4) Cooling fan: Replace once every 3 years.

9.0 External Dimensions / Shipping Dimensions / Weights

9.1 External Dimensions 15/25/30 kVA

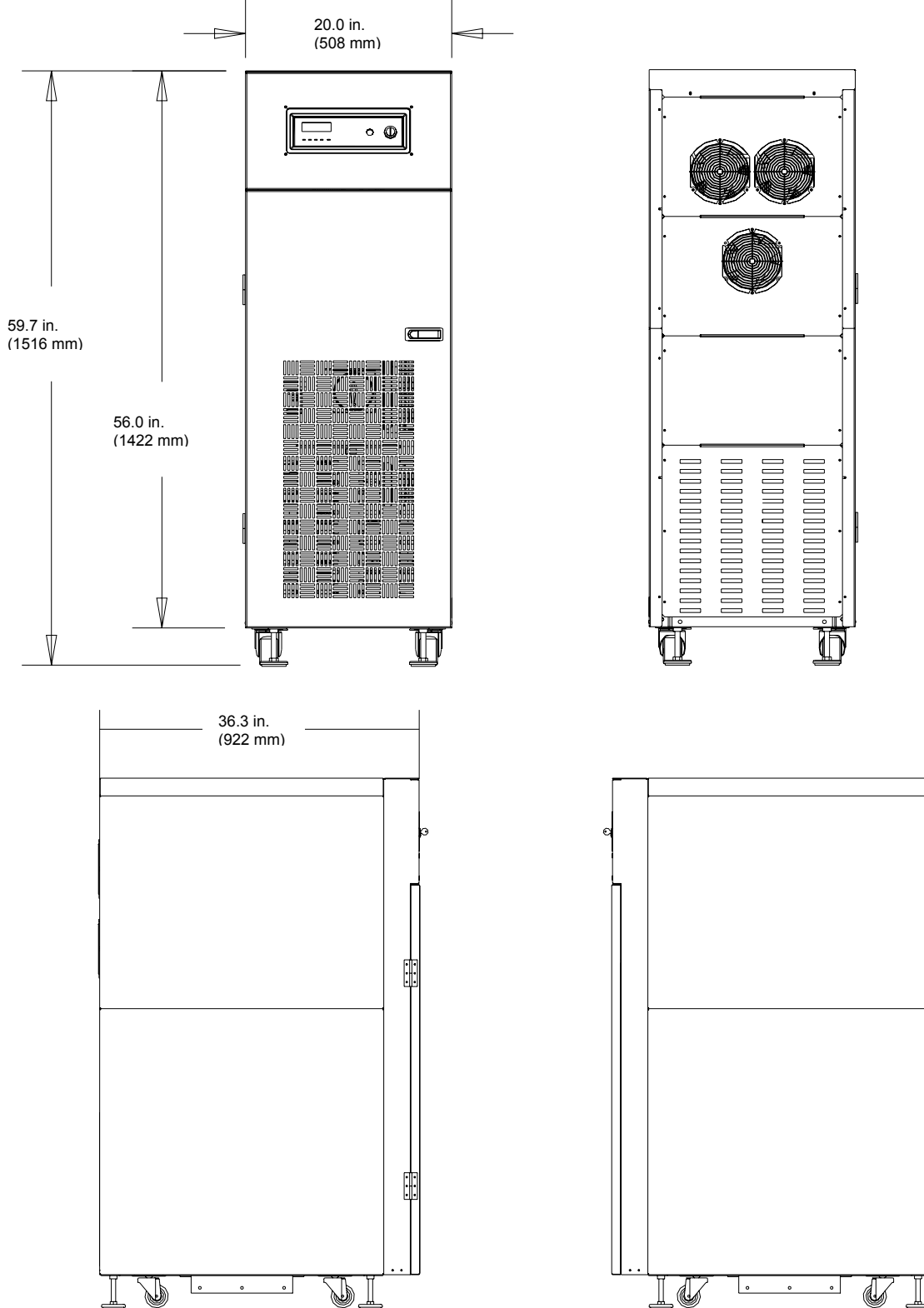

9.2 External Dimensions 50kVA

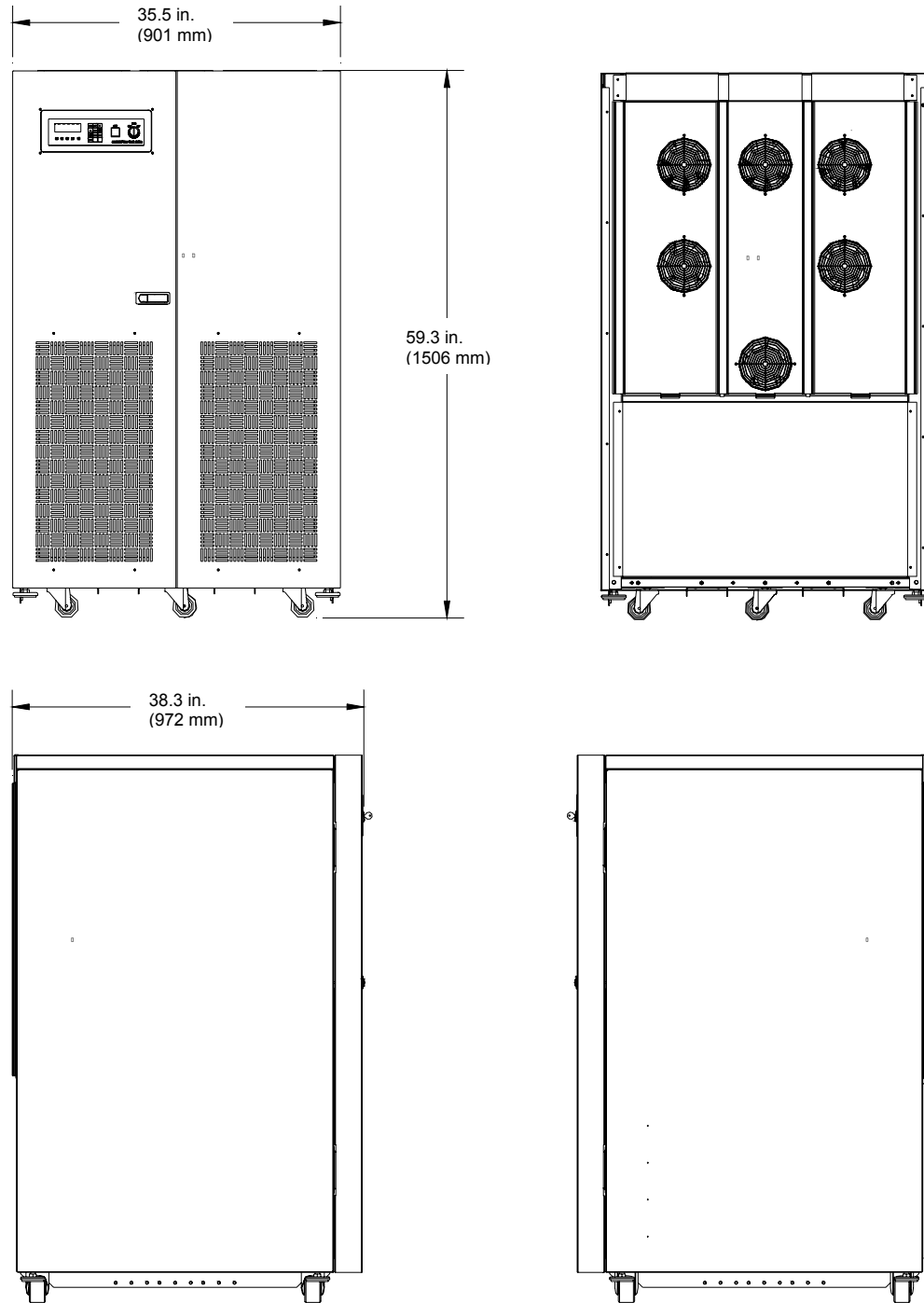

9.3 Shipping Dimensions and Weights

| All 15, 25 & 30 kVA models | Shipping Dimensions, Standard Inches (cm) | Shipping Dimensions, with crate Inches (cm) |
|------------------------------|-------------------------------------------------|---------------------------------------------------|
| Width | 42.8 (109) | 43.5 (111) |
| Depth | 49.0 (125) | 49.8 (127) |
| Height | 64.6 (164) | 69.6 (177) |
| Height with packing material | 67.6 (172) | 69.6 (177) |

| All 50 kVA models | Shipping Dimensions, Standard Inches (cm) | Shipping Dimensions, with crate Inches (cm) |
|------------------------------|-------------------------------------------------|---------------------------------------------------|
| Width | 54.0 (137) | 54.8 (139) |
| Depth | 48.0 (122) | 50.3 (128) |
| Height | 64.3 (163) | 69.9 (178) |
| Height with packing material | 67.3 (171) | 69.9 (178) |

| Model | Shipping Weight, Standard Pounds (Kilograms) | Shipping Weight, with crate Pounds (Kilograms) |
|------------------------------------------------------------|-------------------------------------------------|---------------------------------------------------|
| 15 - 30 kVA with internal battery | 1015 (460) | 1090 (494) |
| 15 - 30 kVA with no internal transformer or battery | 815 (370) | 890 (404) |
| 15 - 30 kVA with 1 internal transformer | 900 (408) | 975 (442) |
| 15 - 30 kVA with 2 internal transformers | 1100 (499) | 1175 (533) |
| 50 kVA with internal battery | 2650 (1202) | 2750 (1247) |
| 50 kVA with no internal transformer or battery | 1800 (816) | 1900 (862) |
| 50 kVA with 1 internal transformer | 1700 (771) | 1800 (816) |
| 50 kVA with 2 internal transformers | 2050 (930) | 2150 (975) |

TOSHIBA

TOSHIBA INTERNATIONAL CORPORATION

INDUSTRIAL DIVISION

13131 West Little York Rd., Houston, TX 77041

Tel: 713/466-0277 Fax 713/466-8773

US 877/867-8773 Canada 800/872-2192 Mexico 01/800/527-1204

www.toshiba.com/ind

Printed in the U.S.A.

Free Manuals Download Website

<http://myh66.com>

<http://usermanuals.us>

<http://www.somanuals.com>

<http://www.4manuals.cc>

<http://www.manual-lib.com>

<http://www.404manual.com>

<http://www.luxmanual.com>

<http://aubethermostatmanual.com>

Golf course search by state

<http://golfingnear.com>

Email search by domain

<http://emailbydomain.com>

Auto manuals search

<http://auto.somanuals.com>

TV manuals search

<http://tv.somanuals.com>