

# TOSVERT VF-AS1/PS1

---

Commercial Power Supply Backup and  
Commercial Power Supply/Inverter Switching  
Instruction Manual

---

Technical information described in this document is used to explain typical operations and applications of products, and this is not intended to grant warranty or licensing right on its use regarding TOSHIBA group or a third party intellectual property and other right.

**- Contents -**

1. Commercial Power Supply Backup.....	2
1.1. Standard connection diagram.....	2
1.1.1. Switching circuit connection diagram, Time chart, Parameter settings .....	3
1.2. Standard connection diagram (Star-delta switching start).....	4
1.2.1. Switching circuit connection diagram, Time chart, Parameter settings .....	5
1.3. Precautions .....	6
2. Commercial Power Supply/Inverter Switching .....	7
2.1. Standard connection diagram.....	7
2.1.1. Switching circuit connection diagram, Time chart, Parameter settings .....	8
2.2. Precautions .....	9

# 1. Commercial Power Supply Backup

When the inverter's protective function is activated, switching power to commercial power supply makes the motor run immediately.

## 1.1. Standard connection diagram

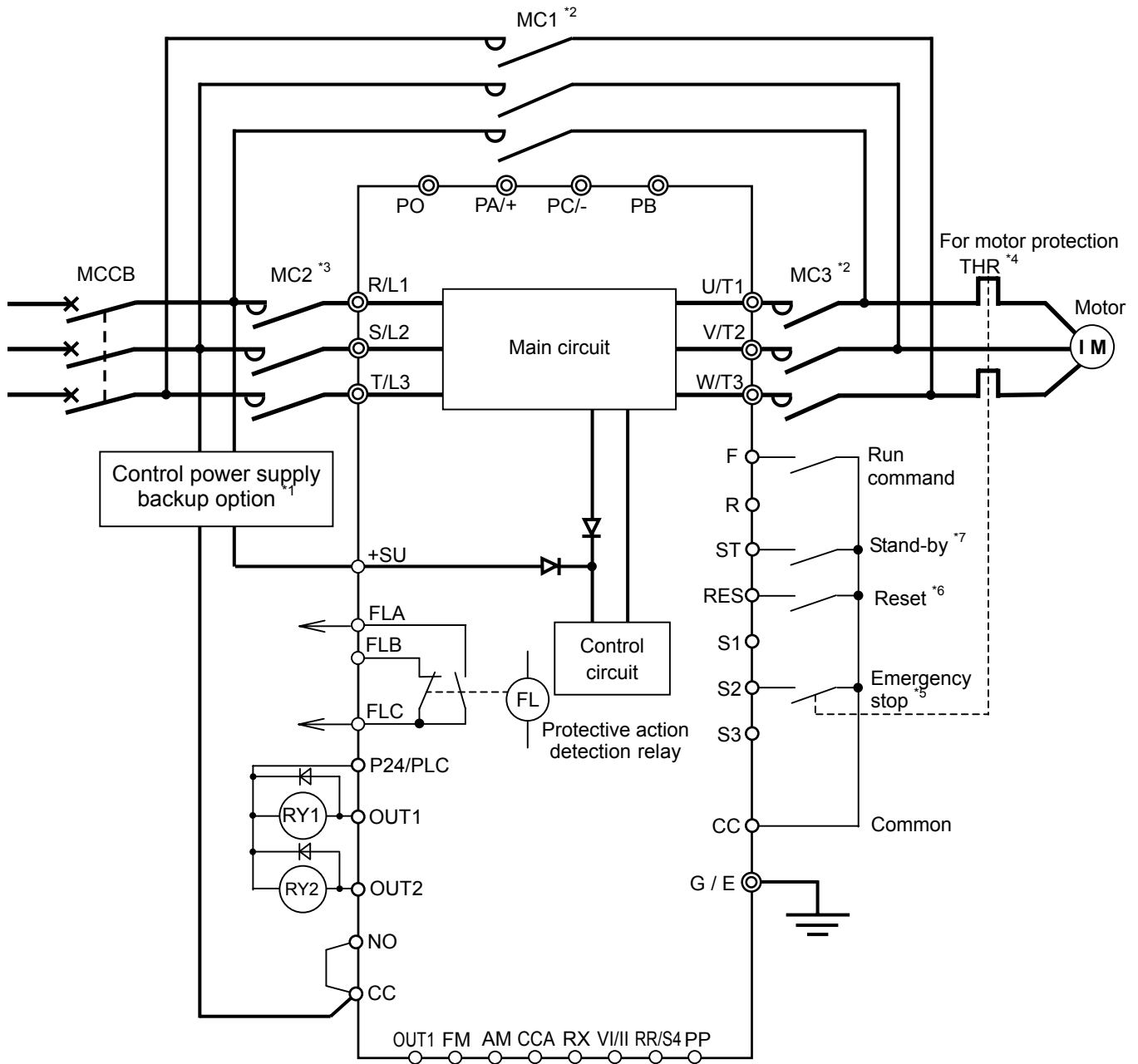

\*1: The control power supply backup option (Model: CPS002Z) is needed.  
 \*2: Observe the Item 1 in 1.3, "Precautions."  
 \*3: See Item 2 in 1.3, "Precautions."  
 \*4: Be careful about Items 3 in 1.3, "Precautions."  
 \*5: Be careful about Items 5 and 7 in 1.3, "Precautions."  
 \*6: Be careful about Item 6 in 1.3, "Precautions."

\*7: VF-AS1's 'WP1/WN1' model and VF-PS1 don't have 'ST' terminal. Please set next parameter for use 'S3' terminal as 'ST' function.

F 1 1 0 (Always ON function selection 1) = 0  
 F 1 1 7 (Input terminal function selection: S3) = 5

### 1.1.1. Switching circuit connection diagram, Time chart, Parameter settings

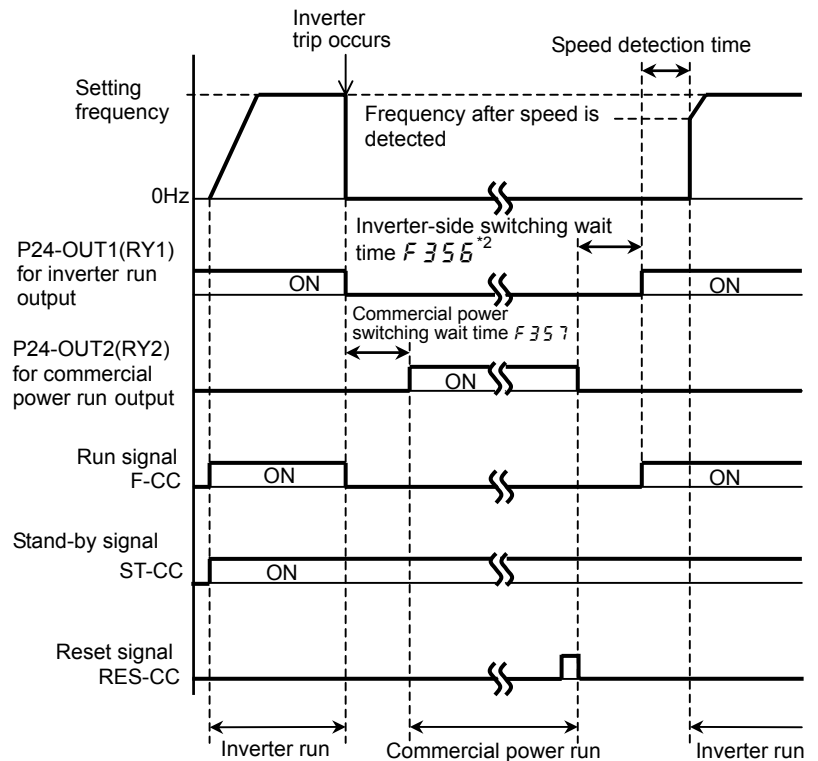
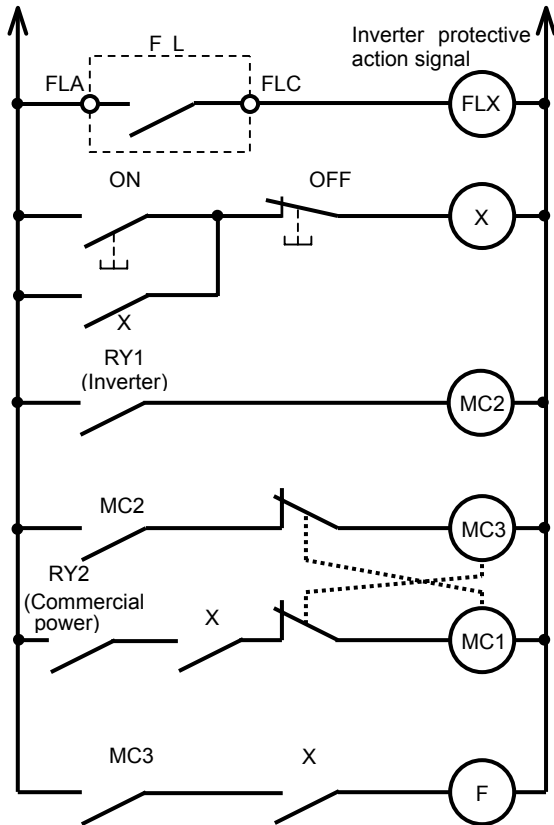

Title	Function	Adjustment range	Setting value
<i>F 354</i>	Output signal selection of commercial power/inverter switching	0 to 3	1 (Automatic switching in case of trip)
<i>F 356</i> <sup>*3</sup>	Inverter side switching waiting time	0.1 to 10.0 seconds	Different for each model
<i>F 357</i> <sup>*3</sup>	Commercial power side switching waiting time	0.37 to 10.0 seconds	0.62
<i>F 116</i> <sup>*1</sup>	Input terminal selection #6 (S2)	0 to 135	20 (Emergency stop)
<i>F 130</i>	Output terminal selection #1 (OUT1)	0 to 119	46 (Commercial power/inverter switching output 1)
<i>F 131</i>	Output terminal selection #2 (OUT2)	0 to 119	48 (Commercial power/inverter switching output 2)

\*1:Be careful about Items 5 and 7 in 1.3, "Precautions."

\*2:Due to internal processing timing, inverter-side wait time become 0.5 second longer than the setting value of *F 356*.

\*3:*F 356* and *F 357* are included the operation time of the relay and the magnet contactor.

In almost all cases, it is not necessary to change these parameter settings.

## 1.2. Standard connection diagram (Star-delta switching start)

This is the circuit to switch the motor to commercial power supply Star Delta (star-delta) connection startup when the inverter's protective function is activated.

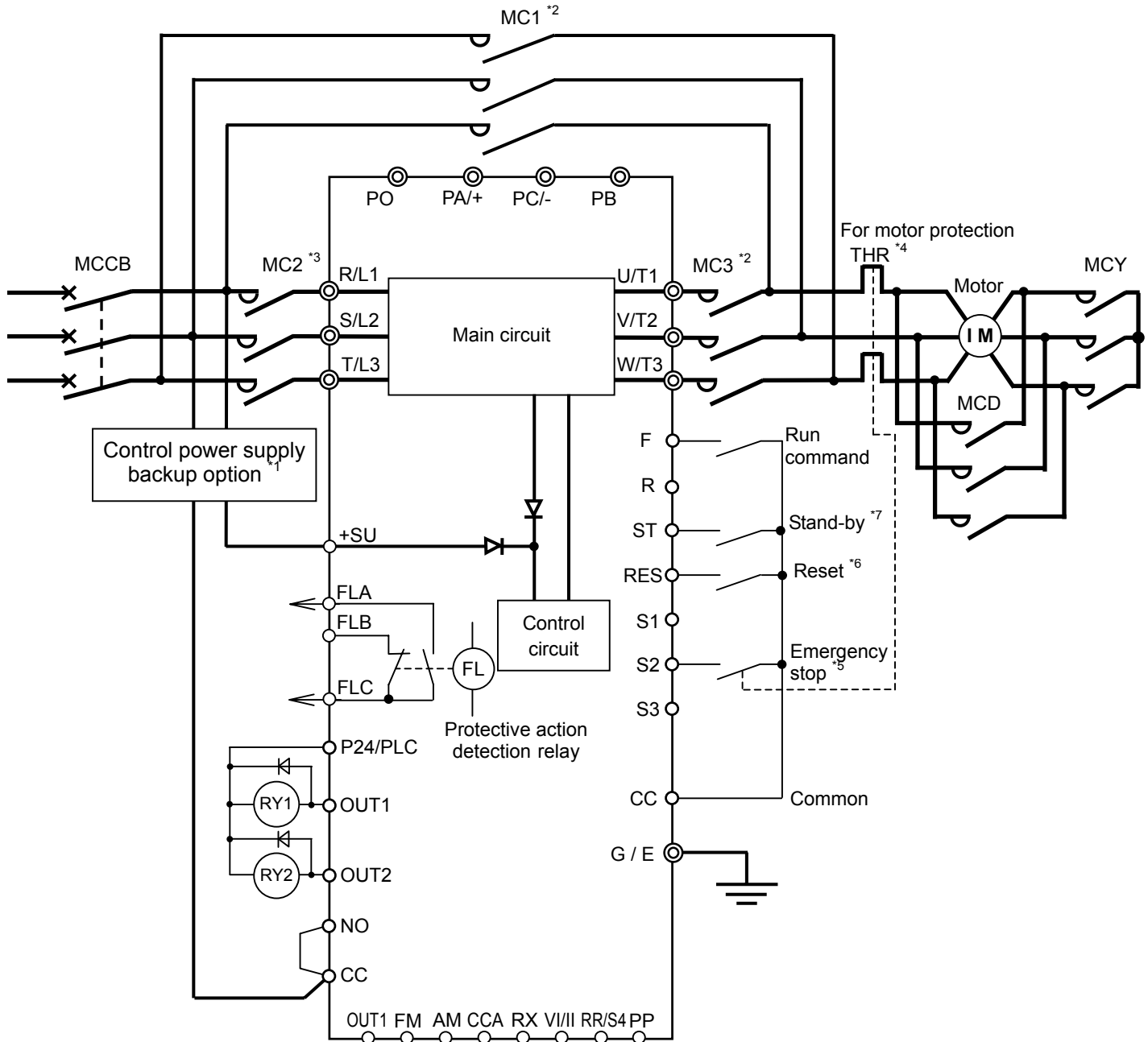

- \*1: The control power supply backup option (Model: CPS002Z) is needed.
- \*2: Observe the Item 1 in 1.3, "Precautions."
- \*3: See Item 2 in 1.3, "Precautions."
- \*4: Be careful about Items 3 in 1.3, "Precautions."
- \*5: Be careful about Items 5 and 7 in 1.3, "Precautions."
- \*6: Be careful about Item 6 in 1.3, "Precautions."

- \*7: VF-AS1's 'WP1/WN1' model and VF-PS1 don't have 'ST' terminal. Please set next parameter for use 'S3' terminal as 'ST' function.

F 1 1 0 (Always ON function selection 1) = 0  
 F 1 1 7 (Input terminal function selection: S3) = 6

### 1.2.1. Switching circuit connection diagram, Time chart, Parameter settings

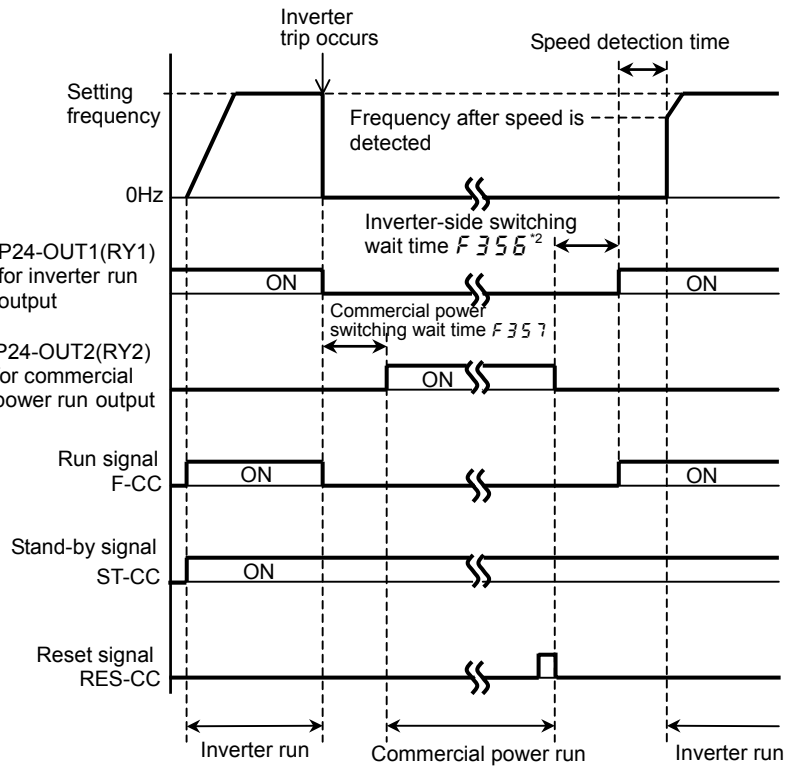
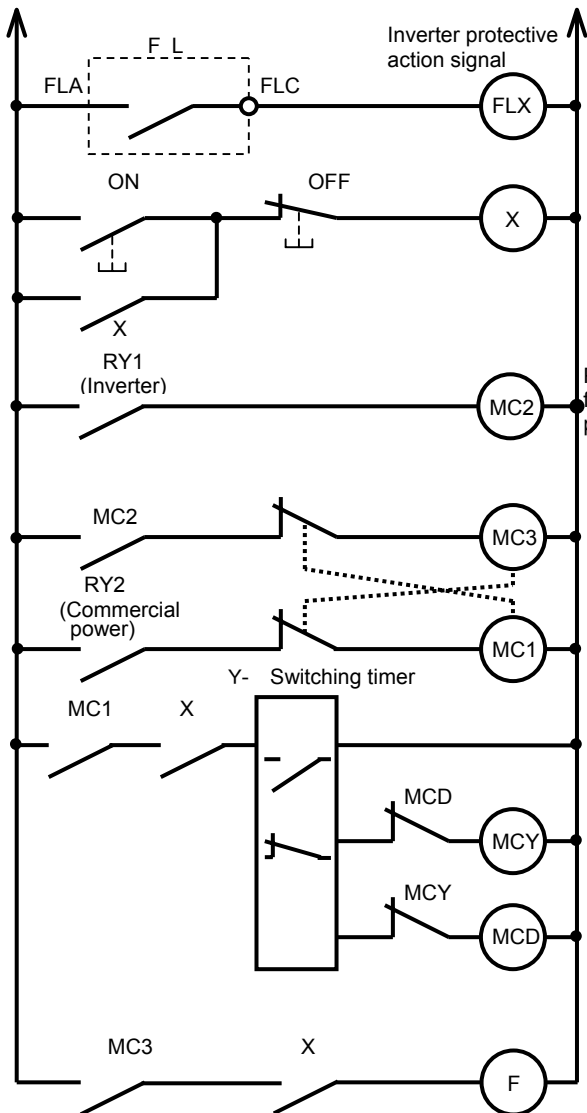

Title	Function	Adjustment range	Setting value
<i>F 354</i>	Output signal selection of commercial power/inverter switching	0 to 3	1 (Automatic switching when tripped)
<i>F 356</i> <sup>*3</sup>	Inverter side switching waiting time	0.1 to 10.0 seconds	Different for each model
<i>F 357</i> <sup>*3</sup>	Commercial power side switching waiting time	0.37 to 10.0 seconds	0.62
<i>F 116</i> <sup>*1</sup>	Input terminal selection #6 (S2)	0 to 135	20 (Emergency stop)
<i>F 130</i>	Output terminal selection #1 (OUT1)	0 to 119	46 (Commercial power/inverter switching output 1)
<i>F 131</i>	Output terminal selection #2 (OUT2)	0 to 119	48 (Commercial power/inverter switching output 2)

\*1:Be careful about Items 5 and 7 in 1.3, "Precautions."

\*2:Due to internal processing timing, inverter-side wait time become 0.5 second longer than the setting value of *F 356*.

\*3:*F 356* and *F 357* are included the operation time of the relay and the magnet contactor.

In almost all cases, it is not necessary to change these parameter settings.

---

## 1.3. Precautions

---

1. Make sure to interlock the magnetic contactor (MC3) on the inverter output side with the commercial power supply magnetic contactor (MC1).
2. Magnetic contactor (MC2) can be omitted for normal operation but this is needed to isolate the inverter circuit in case a short-circuit fault occurs inside the inverter. Examine whether it should be installed or not considering the importance of the system concerned.
3. Check to make sure the phase sequence of the inverter and that of the commercial power supply are the same beforehand to maintain the motor's rotational direction unchanged before and after the power switching.
4. In the *F 311* (Reverse-run prohibition), do not use the forward direction disable setting (*F 311*=2). Switching to commercial power supply cannot be made because the inverter cannot run forward.
5. If the cause of the inverter trip was OCL (short-circuit on the load side at startup), E (emergency stop) or EF1, 2 (ground fault), commercial power supply /inverter switching output 1, 2 (output terminal selection 46, 48) are both shut off and MC1 and MC3 on both inverter and commercial power supply sides disabled and unable to turn on.
6. In case an inverter trip occurs, remove the cause of the protective action and then reset the inverter to start the inverter again.
7. S2 terminal (emergency stop) can be omitted, but it is needed as a circuit to detect a motor overload when the motor is operated on commercial power supply. Examine whether it should be installed or not considering the importance of the system concerned.
8. Regarding the selection of MCCB used when the backup circuit starts in star delta configuration, you have to consider the peak current when star connection is switched to delta connection.
9. In the case the motor's connection is star-delta, use delta connection when the inverter is running. (Do not switch star delta connection while the inverter is running.)

## 2. Commercial Power Supply/Inverter Switching

The motor runs on commercial power supply under rated operating conditions and when the motor runs in energy saving mode with its input power frequency lowered, this circuit switches the motor to the inverter power without stopping the motor.

### 2.1. Standard connection diagram

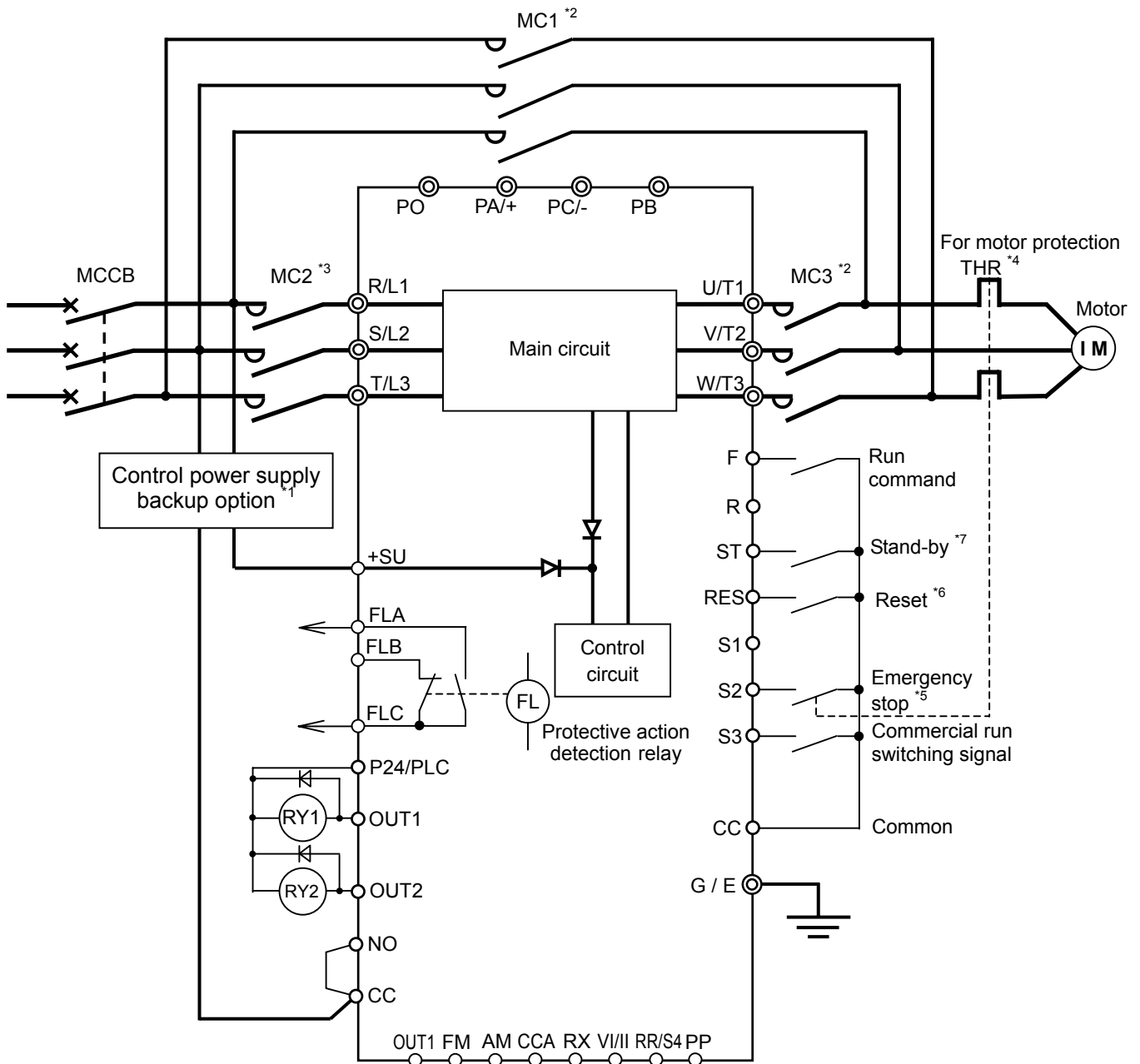

\*1: The control power supply backup option (Model: CPS002Z) is needed.

\*2: Observe the Item 1 in 2.2, "Precautions."

\*3: See Item 2 in 2.2, "Precautions."

\*4: Be careful about Items 3 in 2.2, "Precautions."

\*5: Be careful about Items 5 and 7 in 2.2, "Precautions."

\*6: Be careful about Item 6 in 2.2, "Precautions."

\*7: VF-AS1's 'WP1/WN1' model and VF-PS1 don't have 'ST' terminal. Please set next parameter for use 'S3' terminal as 'ST' function.

F 1 1 0 (Always ON function selection 1) = 0

F 1 1 5 (Input terminal function selection: S1) = 5



## 2.1.1. Switching circuit connection diagram, Time chart, Parameter settings

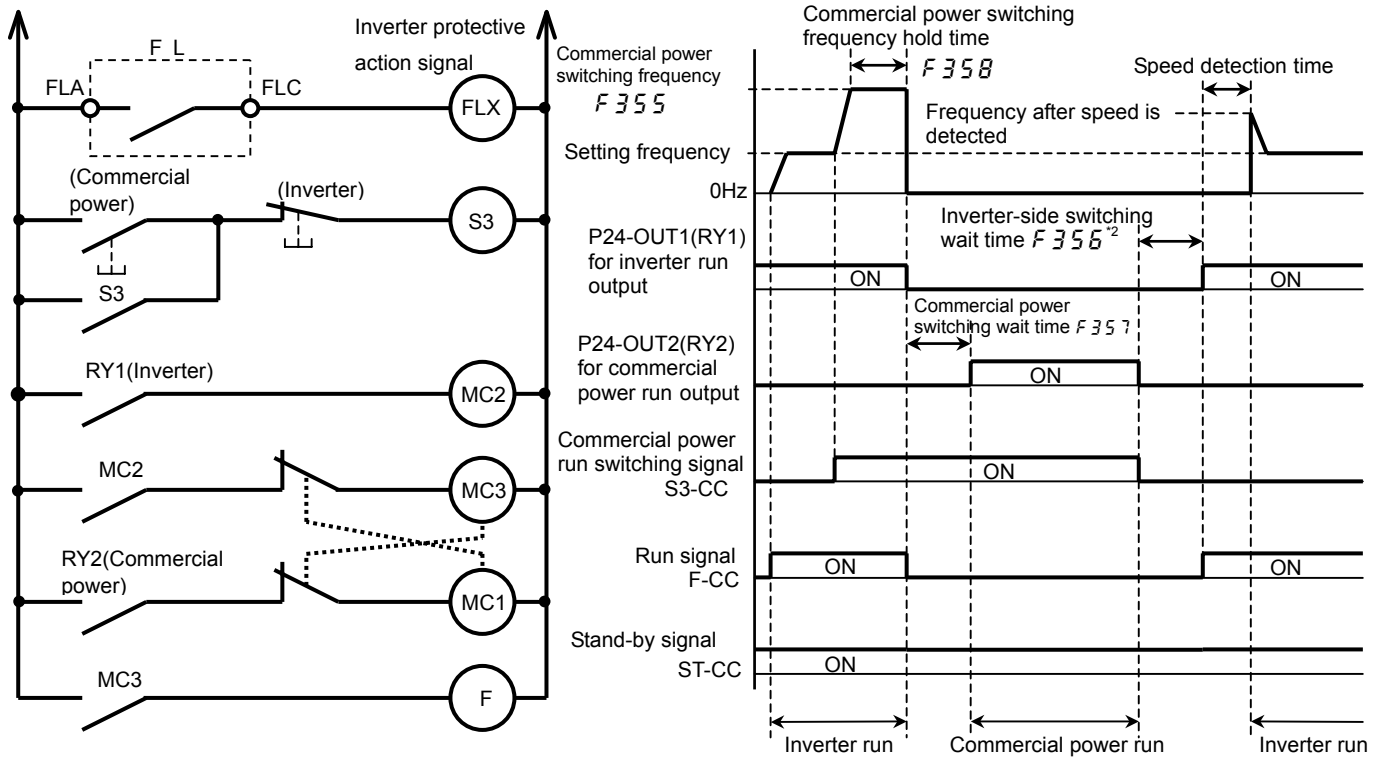

Title	Function	Adjustment range	Setting value
$F_{354}$	Output signal selection of commercial power/inverter switching	0 to 3	2 or 3
$F_{355}$	Commercial power/inverter switching frequency	0 to $F.H.$	Power supply frequency
$F_{356}^{*3}$	Inverter side switching waiting time	0.1 to 10.0 seconds	Different for each model
$F_{357}^{*3}$	Commercial power side switching waiting time	0.37 to 10.0 seconds	0.62
$F_{358}$	Commercial power switching frequency holding time	0.1 to 10.0 seconds	2.0
$F_{116}^{*1}$	Input terminal selection #6 (S2)	0 to 135	20 (Emergency stop)
$F_{117}$	Input terminal selection #7 (S3)	0 to 135	102 (Commercial power run switching)
$F_{130}$	Output terminal selection #1 (OUT1)	0 to 119	46 (Commercial power/inverter switching output 1)
$F_{131}$	Output terminal selection #2 (OUT2)	0 to 119	48 (Commercial power/inverter switching output 2)

\*1:Be careful about Items 5 and 7 in 2.2, "Precautions."

\*2:Due to internal processing timing, inverter-side wait time become 0.5 second longer than the setting value of  $F_{356}$ .

\*3: $F_{356}$  and  $F_{357}$  are included the operation time of the relay and the magnet contactor.

In almost all cases, it is not necessary to change these parameter settings.

---

## 2.2. Precautions

---

1. Make sure to interlock the magnetic contactor (MC3) on the inverter output side with the commercial power supply magnetic contactor (MC1).
2. Magnetic contactor (MC2) can be omitted for normal operation but this is needed to isolate the inverter circuit in case a short-circuit fault occurs inside the inverter. Examine whether it should be installed or not considering the importance of the system concerned.
3. Check to make sure the phase sequence of the inverter and that of the commercial power supply are the same beforehand to maintain the motor's rotational direction unchanged before and after the power switching.
4. In the  $F\bar{3}11$  (Reverse-run prohibition), do not use the forward direction disable setting ( $F\bar{3}11=2$ ). Switching to commercial power supply cannot be made because the inverter cannot run forward.
5. If the cause of the inverter trip was OCL (short-circuit on the load side at startup), E (emergency stop) or EF1, 2 (ground fault), commercial power supply / inverter switching output 1, 2 (output terminal selection 46, 48) are both shut off and MC1 and MC3 on both inverter and commercial power supply sides disabled and unable to turn on.
6. When the setting value for  $F\bar{3}54$  (output signal selection of commercial power supply/inverter switching) is "2", the system does not work even if the commercial power supply switching signal is turned on at the time of an inverter trip.  
To switch to commercial power supply, remove the cause of the protective action and reset the inverter and then enter the switching signal to switch to commercial power supply.
7. S2 terminal (emergency stop) can be omitted, but it is needed as a circuit to detect a motor overload when the motor is operated on commercial power supply. Examine whether it should be installed or not considering the importance of the system concerned.

## Free Manuals Download Website

<http://myh66.com>

<http://usermanuals.us>

<http://www.somanuals.com>

<http://www.4manuals.cc>

<http://www.manual-lib.com>

<http://www.404manual.com>

<http://www.luxmanual.com>

<http://aubethermostatmanual.com>

Golf course search by state

<http://golfingnear.com>

Email search by domain

<http://emailbydomain.com>

Auto manuals search

<http://auto.somanuals.com>

TV manuals search

<http://tv.somanuals.com>