

**CONTENTS**

**Quick Start** ..... 2

**1. Caution Statements**

1.1 Cautions and warnings ..... 3

**2. General Description**

2.1 Feature list ..... 4  
 2.2 Part Number format ..... 4

**3. Specifications**

3.1 Current ratings ..... 5  
 3.2 Dimensions & weights ..... 7  
 3.3 Semiconductor fuses ..... 7  
 3.4 Power terminations ..... 8  
 3.5 General technical data ..... 8

**4. Installation**

4.1 General layout diagrams ..... 9  
 4.2 Power termination configuration ..... 9  
 4.3 Mounting instructions ..... 9  
 4.4 Ventilation ..... 10

**5. Power Circuits**

5.1 Overview ..... 11  
 5.2 3 Wire connection ..... 11  
 5.3 3 Wire connection (Bypass operation) ..... 11  
 5.4 6 Wire connection ..... 11  
 5.5 6 Wire connection (Bypass operation) ..... 11  
 5.6 Power factor correction ..... 11  
 5.7 Line contactors ..... 12

**6. Control Circuits**

6.1 Electrical Schematic ..... 13  
 6.2 Control Supply ..... 13  
 6.3 Control Wiring ..... 13  
 6.4 RS485 Serial Communication ..... 14

**7. Programming & Operation**

7.1 Programming Procedure ..... 17  
 7.2 Function List ..... 18  
 7.3 Function Descriptions ..... 18  
 7.4 Operation ..... 24

**8. Application Examples**

8.1 Installation With Line Contactor ..... 26  
 8.2 Installation With Bypass Contactor ..... 26  
 8.3 Soft Braking ..... 27  
 8.4 Two Speed Motor ..... 28

**9. Trouble Shooting**

9.1 Trip Codes ..... 29  
 9.2 Trip Log ..... 30  
 9.3 General Faults ..... 30  
 9.4 Tests and Measurements ..... 31

**10. Appendix**

10.1 Typical Start Current Requirements ..... 32  
 10.2 AC53a Utilisation Codes ..... 32

10.3 AC53b Utilisation Codes ..... 32

**QUICK START**

For simple applications TMS7 soft starters can be installed using the three simple steps outlined below. For applications with advanced control, protection or interface requirements a comprehensive review of this Users Manual is recommended.

**1. Installation & Connection**



**WARNING - ELECTRICAL SHOCK HAZARD**  
The TMS7 contains dangerous voltages when connected to line voltage. Only a competent electrician should carry out the electrical installation. Improper installation of the motor or the TMS7 may cause equipment failure, serious injury or death. Follow this manual and National Electrical Codes (NEC ®) and local safety codes.

1. Ensure the correct TMS7 model has been selected for the connected motor and application type.
2. Mount the TMS7 making sure to allow adequate clearance top and bottom for the free circulation of air through the starter. (Refer to section 4.3 Mounting Instructions for further detail.)
3. Connect the supply cables to starter input terminals L1, L2 & L3.
4. Connect the motor cables to starter output terminals T1, T2 & T3.
5. Connect a control supply to starter input terminals A1 & A2 or A2 & A3. (Refer to section 6.2 Control Supply for further detail).

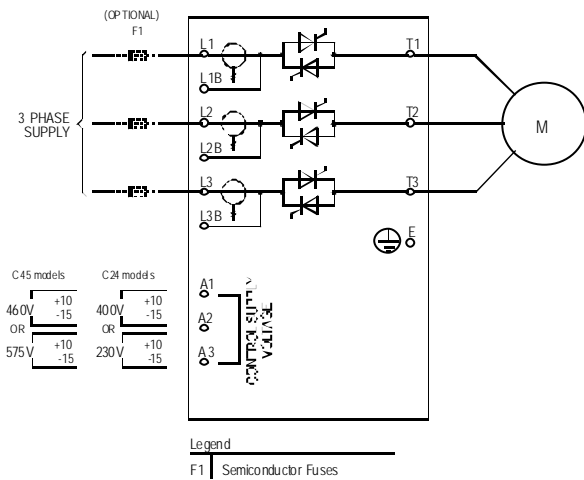

**2. Programming**

Basic application requires only that the TMS7 be programmed with the connected motor's nameplate full load current (FLC). To program the TMS7 with the motor's FLC do the following:

1. Put the TMS7 into program mode by simultaneously pressing then releasing the <FUNCTION> and <STORE> keys.
2. Select Function 1. *Motor Full Load Current* by holding down the <FUNCTION> key and then press the <UP> key until the display shows "1".
3. Release the <FUNCTION> key to display the currently stored value of Function 1. *Motor Full Load Current*.

4. Use the <UP> and/or <DOWN> keys adjust the FLC setting to match the FLC of the connected motor.
5. Press the <STORE> key to store the new FLC setting.
6. Exit the programming mode by simultaneously pressing then releasing the <FUNCTION> and <STORE> keys.



**3. Operation**

The TMS7 is now ready to control the motor. Motor operation can be controlled using the <START> and <STOP> keys on the TMS7 local control panel. Two other commonly used functions that may be useful for basic installations are Function 2. *Current Limit* and Function 5. *Stop Ramp Time*. These functions can be adjusted in the same manner as described above. (For a more detailed description of the programming procedure refer to section 7.1 Programming Procedure.)

### Caution Statements

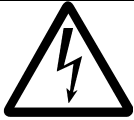

#### WARNING - ELECTRICAL SHOCK HAZARD

The TMS7 contains dangerous voltages when connected to line voltage. Only a competent electrician should carry out the electrical installation. Improper installation of the motor or the TMS7 may cause equipment failure, serious injury or death. Follow this manual and National Electrical Codes (NEC®) and local safety codes.



#### GROUNDING AND BRANCH CIRCUIT PROTECTION

It is the responsibility of the user or person installing the TMS7 to provide proper grounding and branch circuit protection according to the National Electric Code (NEC®) and local codes.



This symbol is used throughout this manual to draw attention to topics of special importance to the installation and operation of the TMS7 soft starter.

It is the installers responsibility to adhere to all instructions in this manual, to follow good electrical practice and to seek advice before operating this equipment in a manner other than as detailed in this manual.

- Ensure that the TMS7 is completely isolated from the power supply before attempting any work on the unit.
- Do not apply voltage to the control input terminals. These are active 12/24VDC inputs and must be controlled with potential free circuits.
- Ensure contacts/switches operating the control inputs are suitable for low voltage, low current switching ie, gold flash or similar.
- Ensure cables to the control inputs are segregated from AC power and control wiring.
- Entry of metal swarf into the cabinet can cause equipment failure.
- Do not connect Power Factor Correction capacitors to the output of the TMS7. If static power factor correction is employed, it must be connected to the supply side of the TMS7.
- Before installing the TMS7 without a line contactor ensure such connection meets local regulations and by-laws.
- If installing the TMS7 within a non-ventilated enclosure a bypass contactor must be utilised to prevent excessive heat build-up.
- If installing a by-pass contactor ensure phase connections are correctly made  
ie L1B-T1, L2B-T2, L3B-T3
- Removing control voltage resets the thermal model.

*The examples and diagrams in this manual are included solely for illustrative purposes. Users are cautioned that the information contained in this manual is subject to change at any time and without prior notice. In no event will responsibility or liability be accepted for direct or indirect or consequential damages resulting from the use or application of this equipment.*

**General Description**

**2.1 Feature List**

**Starting**

- Current Limit mode.
- Ramp Start mode.

**Stopping**

- Soft stop.
- Pump stop.
- Soft braking.

**Protection**

- Overcurrent protection.
- Motor thermistor input.
- Current imbalance.
- Phase rotation.
- Stall protection.
- Undercurrent.
- Supply frequency.
- Shorted SCR.
- Power circuit.
- Motor connection.
- RS485 failure.

**Interface**

- Remote control inputs (4 x fixed).
- Relay outputs (1 fixed, 3 x programmable).
- 4-20mA output (1 x fixed).
- RS485 link.

**Human Interface**

- Local push buttons. (Start, Stop, Reset, Local/Remote)
- Local programming buttons. (Function, Up, Down, Store)
- LED parameter display
- Phase indicator LEDs

**Power connection.**

- 3 Wire
- 6 Wire
- Bypass connections to retain motor protection even when bypassed.
- 17 Amps to 1562 Amps (3 Wire)
- 26 Amps to 2345 Amps (6 Wire)
- 200VAC to 525VAC (V5 models)
- 200VAC to 690VAC (V7 models)

**Sundry features**

- IP42 (<253 Amps)
- IP00 (>302 Amps)
- Current read-out
- Motor temperature read-out
- Fault History (eight position).
- Multiple function sets.
- Restart Delay.
- Low current alarm.
- High current alarm.
- Motor overtemperature alarm.
- Auto-reset.
- Function lock/Password protection.
- Load defaults function settings.

**2.2 Part Number Format**

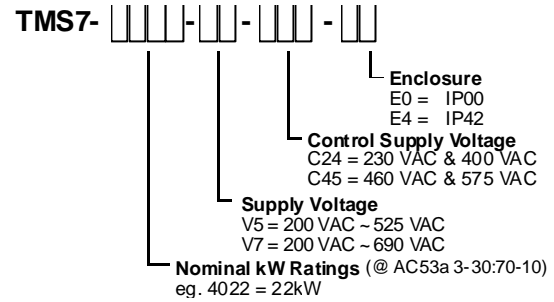

**Specifications**

**3.1 Current Ratings**

**Continuous Operation (Not Bypassed), 3 Wire Connection**

	Start Current (%FLC)			
	300%	350%	400%	450%
	AC53a 3-10:70-10 45°C <1000 metres	AC53a 3.5-15:70-10 45°C <1000 metres	AC53a 4-20:70-10 45°C <1000 metres	AC53a 4.5-30:70-10 45°C <1000 metres
TMS7-4007	17	15	14	12
TMS7-4015	33	29	26	22
TMS7-4018	38	34	30	26
TMS7-4022	44	39	35	30
TMS7-4030	67	58	51	45
TMS7-4037	87	75	66	58
TMS7-4045	94	81	71	62
TMS7-4055	123	106	93	81
TMS7-4075	137	119	105	92
TMS7-4090	198	171	151	132
TMS7-4110	236	204	179	156
TMS7-4132	244	211	186	164
TMS7-4150	302	267	233	201
TMS7-4185	405	361	313	267
TMS7-4220	513	456	393	331
TMS7-4250	585	524	450	376
TMS7-4315	628	568	489	412
TMS7-4400	775	710	606	502
TMS7-4500	897	831	706	578
TMS7-4600	1134	989	872	759
TMS7-4700	1385	1210	1066	921
TMS7-4800	1563	1366	1202	1030

**Continuous Operation (Not Bypassed), 6 Wire Connection**

	Start Current (%FLC)			
	300%	350%	400%	450%
	AC53a 3-10:70-10 45°C <1000 metres	AC53a 3.5-15:70-10 45°C <1000 metres	AC53a 4-20:70-10 45°C <1000 metres	AC53a 4.5-30:70-10 45°C <1000 metres
TMS7-4007	26	23	21	18
TMS7-4015	50	44	39	33
TMS7-4018	57	51	45	39
TMS7-4022	66	59	53	45
TMS7-4030	101	87	77	68
TMS7-4037	131	113	99	87
TMS7-4045	141	122	107	93
TMS7-4055	185	159	140	122
TMS7-4075	206	179	158	138
TMS7-4090	297	257	227	198
TMS7-4110	354	306	269	234
TMS7-4132	366	317	279	246
TMS7-4150	453	401	350	302
TMS7-4185	608	542	470	401
TMS7-4220	770	684	590	497
TMS7-4250	878	786	675	564
TMS7-4315	942	852	734	618
TMS7-4400	1163	1065	909	753
TMS7-4500	1346	1247	1059	867
TMS7-4600	1701	1484	1308	1139
TMS7-4700	2078	1815	1599	1382
TMS7-4800	2345	2049	1803	1545

**Bypassed Operation ,3 Wire Connection**

	Start Current (%FLC)			
	300%	350%	400%	450%
	AC53b 3-10:350 45°C <1000 metres	AC53b 3.5-15:345 45°C <1000 metres	AC53b 4-20:340 45°C <1000 metres	AC53b 4.5-30:330 45°C <1000 metres
TMS7-4007	18	18	16	14
TMS7-4015	34	34	34	28
TMS7-4018	41	41	41	34
TMS7-4022	47	47	47	39
TMS7-4030	67	62	54	47
TMS7-4037	88	82	71	61
TMS7-4045	96	90	78	66
TMS7-4055	125	120	103	88
TMS7-4075	141	127	111	96
TMS7-4090	202	187	162	140
TMS7-4110	238	224	194	166
TMS7-4132	254	228	198	172
TMS7-4150	302	285	245	209
TMS7-4185	405	395	336	282
TMS7-4220	513	513	435	356
TMS7-4250	585	585	504	410
TMS7-4315	628	626	528	436
TMS7-4400	775	775	672	542
TMS7-4500	897	897	798	632
TMS7-4600	1153	1153	1006	850
TMS7-4700	1403	1403	1275	1060
TMS7-4800	1574	1574	1474	1207

**Bypassed Operation, 6 Wire Connection**

	Start Current (%FLC)			
	300%	350%	400%	450%
	AC53b 3-10:350 45°C <1000 metres	AC53b 3.5-15:345 45°C <1000 metres	AC53b 4-20:340 45°C <1000 metres	AC53b 4.5-30:330 45°C <1000 metres
TMS7-4007	27	27	24	20
TMS7-4015	51	51	51	42
TMS7-4018	62	62	62	52
TMS7-4022	71	71	71	59
TMS7-4030	101	94	82	71
TMS7-4037	132	122	106	91
TMS7-4045	144	136	117	99
TMS7-4055	188	181	155	132
TMS7-4075	212	190	166	145
TMS7-4090	303	281	243	210
TMS7-4110	357	336	290	250
TMS7-4132	381	342	297	259
TMS7-4150	453	427	368	314
TMS7-4185	608	592	504	424
TMS7-4220	770	770	653	534
TMS7-4250	878	878	756	614
TMS7-4315	942	939	793	654
TMS7-4400	1163	1163	1009	813
TMS7-4500	1346	1346	1197	948
TMS7-4600	1730	1730	1509	1276
TMS7-4700	2105	2105	1912	1591
TMS7-4800	2361	2361	2212	1811

**3.2 Dimensions & Weights**

	A	B	C	a	b	Weight
	mm	mm	mm	mm	mm	Kg
IP42/NEMA 1						
TMS7-4007	380	185	180	365	130	6
TMS7-4015						
TMS7-4018						
TMS7-4022						
TMS7-4030	380	185	250	365	130	7
TMS7-4037						
TMS7-4045						
TMS7-4055						
TMS7-4075						
TMS7-4090	425	270	275	410	200	17.5
TMS7-4110						
TMS7-4132						
IP00						
TMS7-4150	690	430	294	522	320	42
TMS7-4185						
TMS7-4220						
TMS7-4250						
TMS7-4315						49
TMS7-4400						
TMS7-4500						
TMS7-4600	855	574	353	727	500	120
TMS7-4700						
TMS7-4800						

TMS7-4007 ~ TMS7-4132

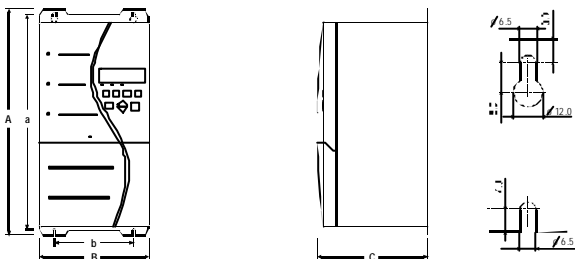

TMS7-4150 ~ TMS7-4800

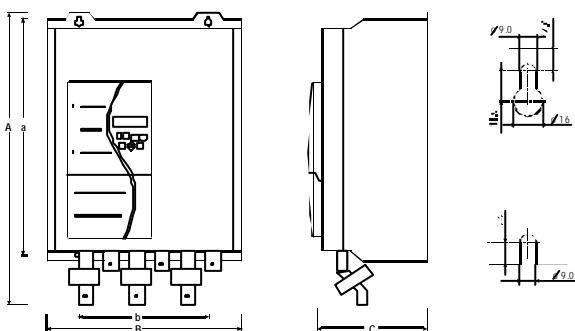

**3.3 Semiconductor Fuses**

Semiconductor fuses can be used with the TMS7 to reduce the potential of damage to SCRs from transient overload currents and for Type 2 coordination. Suitable Bussman semiconductor fuses are detailed below.

F Series Fuses	Supply Voltage				Starter I <sup>2</sup> t
	≤415VAC	≤525VAC	≤575VAC	≤695VAC	
TMS7-4007	63AFE	63AFE	63AFE	63AFE	1,150
TMS7-4015	160AFEE	160AFEE	160AFEE	160AFEE	10,500
TMS7-4018	200FM	180FM	180FM	180FM	15,000
TMS7-4022	200FM	180FM	180FM	180FM	18,000
TMS7-4030	200FM	180FM	180FM	180FM	15,000
TMS7-4037	250FM	250FM	250FM	250FM	51,200
TMS7-4045	250FM	250FM	250FM	250FM	80,000
TMS7-4055	250FM	250FM	250FM	250FM	97,000
TMS7-4075	280FM	280FM	280FM	280FM	97,000
TMS7-4090	500FMM	450FMM	450FMM	450FMM	145,000
TMS7-4110	630FMM	630FMM	630FMM	630FMM	414,000
TMS7-4132	630FMM	630FMM	630FMM	630FMM	414,000
TMS7-4150	630FMM	500FMM	500FMM	500FMM	211,000
TMS7-4185	500FMM	500FMM	500FMM	500FMM	320,000
TMS7-4220	700FMM	700FMM	700FMM	700FMM	781,000
TMS7-4250	*500FMM	*500FMM	*500FMM	*500FMM	1,200,000
TMS7-4315	*500FMM	*500FMM	*500FMM	*500FMM	1,200,000
TMS7-4400	*700FMM	*700FMM	*700FMM	*700FMM	2,532,000
TMS7-4500	-	-	-	-	4,500,000
TMS7-4600	-	-	-	-	4,500,000
TMS7-4700	-	-	-	-	6,480,000
TMS7-4800	-	-	-	-	12,500,000

170M Series Fuses	Supply Voltage				Starter I <sup>2</sup> t
	≤415VAC	≤525VAC	≤575VAC	≤695VAC	
TMS7-4007	170M1315	170M1314	170M1314	170M1314	1,150
TMS7-4015	170M1319	170M1317	170M1317	170M1317	10,500
TMS7-4018	170M1319	170M1318	170M1318	170M1318	15,000
TMS7-4022	170M1319	170M1318	170M1318	170M1318	18,000
TMS7-4030	170M1319	170M1318	170M1318	170M1318	15,000
TMS7-4037	170M3017	170M3017	170M3017	170M3017	51,200
TMS7-4045	170M1322	170M1321	170M1321	170M1321	80,000
TMS7-4055	170M1322	170M1322	170M1322	170M1322	97,000
TMS7-4075	170M1322	170M1322	170M1322	170M1322	97,000
TMS7-4090	170M6141	170M6141	170M6141	170M6141	145,000
TMS7-4110	170M3023	170M3023	170M3023	170M3023	414,000
TMS7-4132	170M3023	170M3023	170M3023	170M3023	414,000
TMS7-4150	170M5144	170M5144	170M5144	170M5144	211,000
TMS7-4185	170M6012	170M4016	170M6011	170M6011	320,000
TMS7-4220	170M6014	170M6014	170M4018	170M4018	781,000
TMS7-4250	170M5017	170M6015	170M6014	170M6014	1,200,000
TMS7-4315	170M6019	170M6018	170M6017	170M6017	1,200,000
TMS7-4400	170M6021	170M6020	170M6017	170M6017	2,532,000
TMS7-4500	170M6021	170M6020	170M6151	170M6151	4,500,000
TMS7-4600	170M6021	170M6020	170M6151	170M6151	4,500,000
TMS7-4700	170M6021	170M6021	*170M5018	*170M5018	6,480,000
TMS7-4800	170M6021	170M6021	*170M5018	*170M5018	12,500,000

\*Two parallel connected fuses required per phase

3.4 Power Terminations

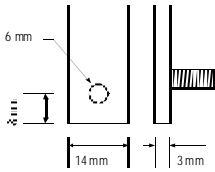

TMS7-4007- TMS7-4022  
(3.5 NM, 2.6 FT-LBS)

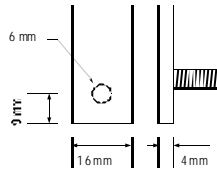

TMS7-4030- TMS7-4055  
(3.5 NM, 2.6 FT-LBS)

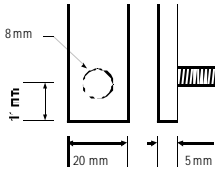

TMS7-4075  
(8.5 NM, 6.3 FT-LBS)

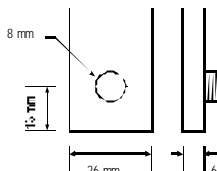

TMS7-4090 - TMS7-4110  
(8.5 NM, 6.3 FT-LBS)

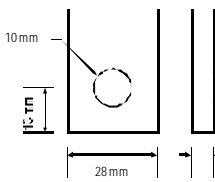

TMS7-4132  
(17 NM, 12.5 FT-LBS)

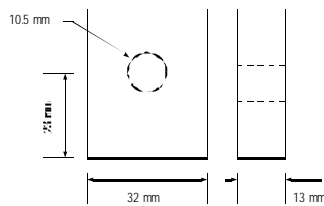

TMS7-4150 - TMS7-4500

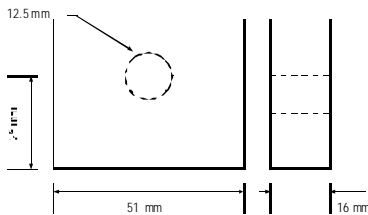

TMS7-4600 - TMS7-4800

3.5 General Technical Data

Supply

- Supply voltage (V5 models) ..... 3 x 200-525VAC (3 Wire Connection)  
3 x 200-440VAC (6 Wire Connection)
- Supply voltage (V7 models) .... 3 x 200- 690VAC (3 Wire Connection)  
3 x 200-440VAC (6 Wire Connection)
- Electronics Supply (C24 models) ..... 230VAC (+10%/-15%)  
or 400VAC (+10%/-15%)
- Electronics Supply (C45 models) ..... 460VAC (+10%/-15%)  
or 575VAC (+10%/-15%)
- Supply frequency (at start) ..... 50Hz (± 2Hz)  
or 60Hz (±2Hz)
- Supply frequency (during start) ..... > 45Hz (50Hz supply)  
or > 55Hz (60Hz supply)
- Supply frequency (during run) ..... >48Hz (50Hz supply)  
or > 58Hz (60Hz supply)

Control Inputs

- Start (I34,I33) ..... Normally Open, Active 24VDC, 8mA approx.
- Stop (I22,I21) ..... Normally Closed, Active 24VDC, 8mA approx.
- Reset (I12,I11) ..... Normally Closed, Active 24VDC, 8mA approx.
- FLC Select (I44,I43) .....Normally Open, Active 24VDC, 8mA approx.

Outputs

- Run Output (R34,R33) ..... Normally Open, 5A @ 250VAC/360VA  
..... 5A @ 30VDC resistive
- Prog. Output A (R44,R43) ..... Normally Open, 5A @ 250VAC/360VA  
..... 5A @ 30VDC resistive
- Prog. Output B (R24,R23) .... Normally Open, 5A @ 250VAC/360VA,  
..... 5A @ 30VDC resistive
- Prog Output C (R14,R12,R11) ... Changeover, 5A @ 250VAC/360VA  
.....5A @ 30VDC resistive
- Analogue Output (C6,C7) ..... 4-20mA

Sundry

- Enclosure Rating TMS7-4007-4132 ..... IP42 (NEMA 1)
  - Enclosure Rating TMS7-4150-4800 ..... IP00 (Open Chassis)
  - Rated short-circuit current (with semi-conductor fuses) ..... 100kA
  - Rated insulation voltage ..... 690 V
  - Surges ..... 2kV line to earth, 1kV line to line
  - Fast transients ..... 2.0kV / 5.0 kHz
  - Rated impulse withstand voltage ..... 2 kV
  - Form designation ..... Form 1
  - Electrostatic discharge ..... 4kV contact discharge, 8 kV air discharge
  - Equipment class (EMC) ..... Class A<sup>1</sup>
  - Radio-frequency electromagnetic field 0.15 MHz - 80 MHz: 140dBµV  
.....80 MHz - 1 GHz: 10 V/m
  - Pollution degree ..... Pollution Degree 3
  - Operating Temperatures ..... -5°C / +60°C
  - Relative Humidity ..... 5 - 95% (max non condensing)
- <sup>1</sup> This product has been designed for class A equipment. Use of the product in domestic environments may cause radio interference, in which case the user may be required to employ additional mitigation methods.

Standards Approvals

- CE ..... IEC 60947-4-2
  - UL<sup>1</sup> ..... UL508
  - C-UL<sup>1</sup> ..... CSA 22.2 No.14
  - C✓ ..... AS/NZS 3947-4-2, CISPR-11
- <sup>1</sup> Requires the use of semi-conductor fuses; is applicable for supply voltages up to 600V; excludes models TMS-4600 - TMS7-4800.



**Installation**

**6.1 General Layout Diagrams**

TMS7-4007 ~ TMS7-4055

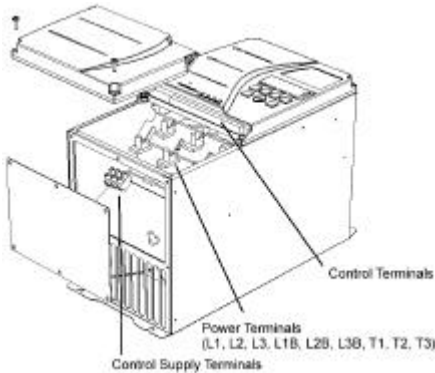

TMS7-4075 ~ TMS7-4132

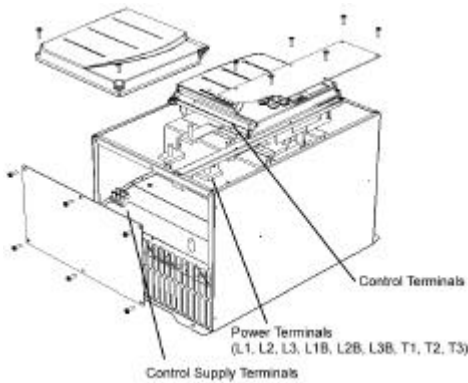

TMS7-4150 ~ TMS7-4800

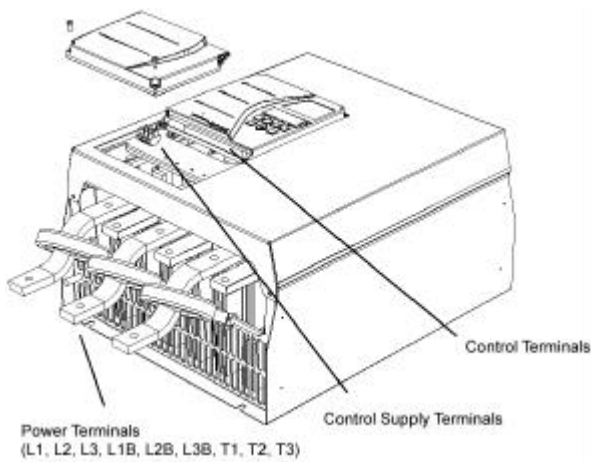

**4.2 Power Termination Configuration**

The bus bars on models TMS7-4150 ~ TMS7-4800 can be adjusted to provide four different input/output power terminal configurations.

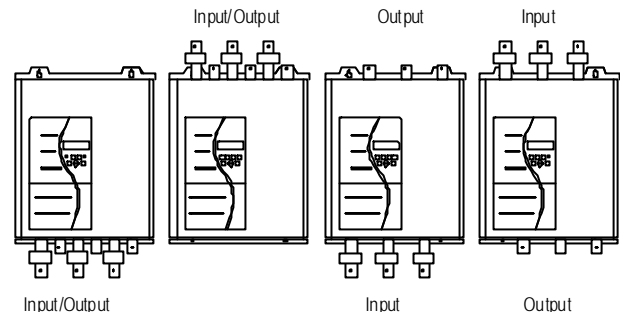

To adjust the bus bar configuration first remove the TMS7 cover and main control module. Next loosen and remove the bus bar fixing bolts. The bus bars can then be removed and reinstalled into the starter in the desired configuration. The fixing bolts should then be refitted and tightened to a torque of 8.5NM.

When re-orienting bus bars L1, L2, L3 the current transformers must also be relocated.

Care must be taken to ensure that foreign matter does not contaminate the jointing compound and become trapped between the bus bar and its mounting plate. If the paste does become contaminated, clean and replace with a jointing compound suitable for aluminium to aluminium, or aluminium to copper joints.

**4.3 Mounting Instructions**

Models TMS7-4007 ~ 4132 can be wall mounted or installed inside another enclosure. These models can be mounted side by side with no clearance but a 100mm allowance must be made top and bottom for air intake and exhaust.

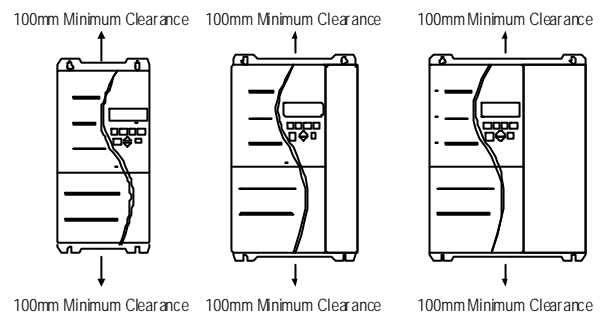

Models TMS7-4150 ~ 4800 have an IP00 rating and must be mounted in another enclosure. These models can be mounted side by side with no clearance but a 200mm allowance must be made top and bottom for air intake and exhaust.

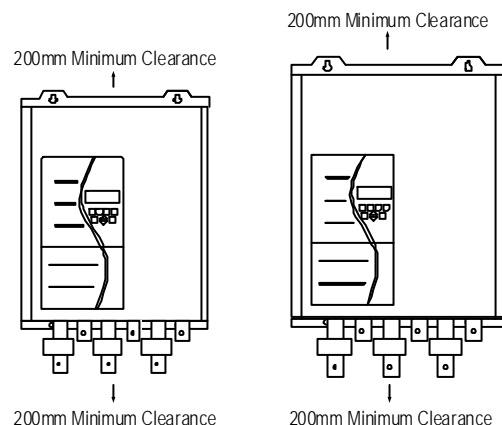

**4.4 Ventilation**

When installing TMS7 starters in an enclosure there must be sufficient air flow through the enclosure to limit heat rise within the enclosure. Temperature within the enclosure must be kept at, or below, the TMS7 maximum ambient temperature rating.

If installing an TMS7 within a totally sealed enclosure a bypass contactor must be employed to eliminate heat dissipation from the soft starter during run.

Soft starters dissipate approximately 4.5 watts per amp. The table below shows air flow requirements for selected motor currents. If other heat sources are installed in an enclosure along with the TMS7 an additional air flow allowance must be made for these items. Note that heat generation from semiconductor fuses, if used, can be eliminated by installing these within the bypass loop.

Motor Amps	Heat (watts)	Required Airflow			
		m <sup>3</sup> /min		m <sup>3</sup> /hour	
		5°C Rise	10°C Rise	5°C Rise	10°C Rise
10	45	0.5	0.2	30	15
20	90	0.9	0.5	54	27
30	135	1.4	0.7	84	42
40	180	1.8	0.9	108	54
50	225	2.3	1.1	138	69
75	338	3.4	1.7	204	102
100	450	4.5	2.3	270	135
125	563	5.6	2.8	336	168
150	675	6.8	3.4	408	204
175	788	7.9	3.9	474	237
200	900	9.0	4.5	540	270
250	1125	11.3	5.6	678	339
300	1350	13.5	6.8	810	405
350	1575	15.8	7.9	948	474
400	1800	18.0	9.0	1080	540
450	2025	20.3	10.1	1218	609
500	2250	22.5	11.3	1350	675
550	2475	24.8	12.4	1488	744
600	2700	27.0	13.5	1620	810

**Power Circuits**

**5.1 Overview**

TMS7 starters can be wired with a number of different power circuits depending on application requirements.

**5.2 3 Wire Connection**

This is the standard connection format. Supply voltage is connected to the starter input terminals L1, L2 & L3. The motor cables are connected to the soft starter output terminals T1, T2 & T3.

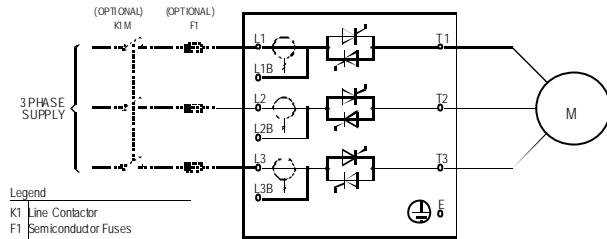

**5.3 3 Wire Connection (Bypassed Operation)**

TMS7 starters can be bypassed while the motor is running. Special terminals (L1B, L2B, L3B) are provided for connection of the bypass contactor. Use of these terminals enables the TMS7 to continue to provide all protection and current monitoring functions even when bypassed.

The TMS7 Run Output (Terminals R34 & R33) should be used to control operation of the bypass contactor. The bypass contactor can be AC1 rated for the motor full load current.

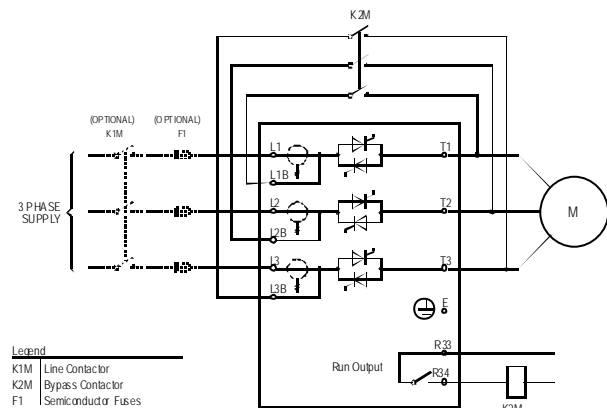

**5.4 6 Wire Connection**

TMS7 units are capable of 6 Wire (Inside Delta) connection as well as 3 Wire connection. When connected in this configuration the soft starter carries only phase current, this means the motor FLC current can be 50% greater than the soft starter's FLC current rating.

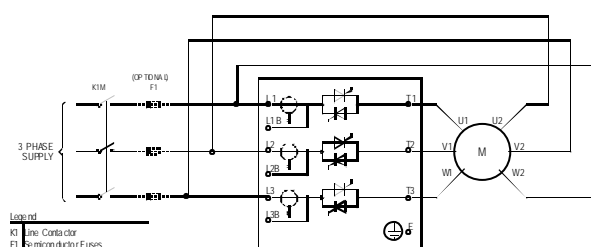

Connect the three OUTPUT terminals (T1, T2, T3) of the TMS7 to the motor windings ensuring that the connections are made to one end of each winding only. It is imperative to connect the output of the TMS7 to the same end of each winding and this is usually marked on the motor terminations.

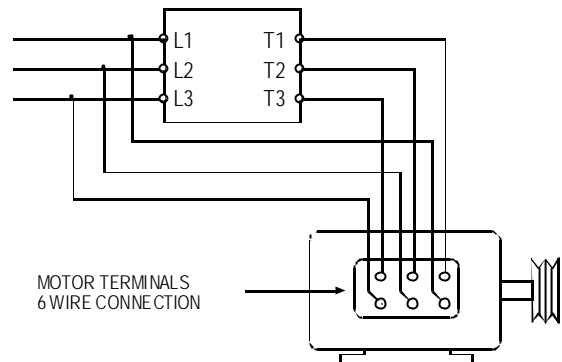

The six terminations to the motor windings are usually arranged in two rows of three so that the links can be fitted across from the top three terminations to the lower terminations. In this case connect the TMS7 to the top terminations only. Connect the other three motor terminals to the input of the TMS7 in a manner that connects the end of each winding to a different phase from the input.

This is most easily achieved by replacing each delta link in the motor terminal box by one phase of the controller. For example if the delta links are fitted U1-V2, V1-W2, W1-U2

- Connect the incoming phases to L1, L2, L3 on the TMS7.
- Connect the TMS7 to the motor. T1-U1, T2-V1, T3-W1
- Connect the other motor terminals to the TMS7's input W2-L1, U2-L2, V2-L3

**5.5 6 Wire Connection (Bypassed Operation)**

TMS7 units are capable of 6 Wire (Inside Delta) connection and can be bypassed.

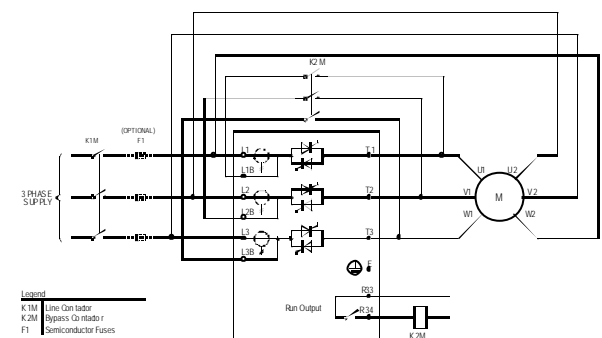

**5.6 Power Factor Correction**

If static power factor correction is employed, it must be connected to the supply side of the soft starter.



**CAUTION:**  
Under no circumstance should power factor correction capacitors be connected between the soft starter and the motor. Connecting power factor correction capacitors to the output of the soft starter will result in damage to the soft starter.

### 5.7 Line contactors

The TMS7 is designed to operate with or without a line contactor. In many regions there is a statutory requirement that a line contactor be employed with electronic motor control equipment. From a safety point of view, this is the preferable option, however is not necessary for starter operation. An additional benefit gained by use of a line contactor is isolation of the starter SCR's in the off state, when they are most susceptible to damage from voltage transients.

The TMS7 can directly control a line contactor via the Main Contactor Control output.

As an alternative to a line contactor, either a circuit breaker with a no volt release coil operated by the TMS7 trip output, or a motor operated circuit breaker can be considered. If a motor operated circuit breaker is used as a line contactor, the potential delay between the breaker being told to close and phase power being applied to the TMS7 could cause the TMS7 to trip on installation faults. Closing the motorized breaker directly and using the breaker's auxiliary contacts, or preferably a slave relay with gold flash contacts, to control the TMS7 can avoid this.

Line contactors must be selected such that their AC3 rating is equal to or greater than the full load current rating of the connected motor.

**Control Circuits**

**6.1 Electrical Schematic**

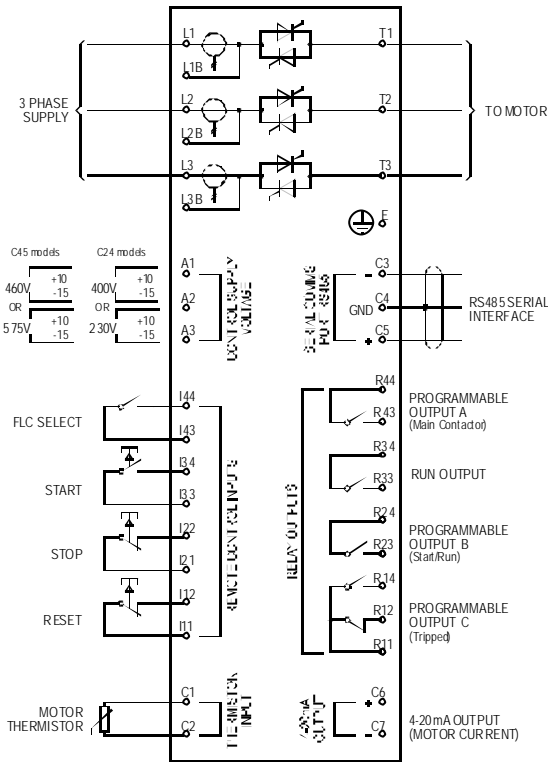

**6.2 Control Supply**

Voltage must be connected to the TMS7 control voltage terminals. The required control voltage is dependent upon the TMS7 model ordered.

- TMS7xxx-xx-**C24**-xx models: 230VAC (A2-A3) or 400VAC (A1-A2)
- TMS7xxx-xx-**C45**-xx models: 460VAC (A1-A2) or 575VAC (A2-A3)

TMS7 Model	Maximum VA
TMS7-4007~TMS7-4022	11VA
TMS7-4030~TMS7-4055	18VA
TMS7-4075~TMS7-4110	24VA
TMS7-4132~TMS7-4500	41VA
TMS7-4600~TMS7-4800	56VA

For circumstances where the available control supply voltage is not suitable for direct connection to the TMS7 the following range of auto-transformers are available as accessories. These auto-transformers can be mounted within the TMS7 in models.

Input Voltages (C24 Models)	Part Number		
	TMS7-4007~TMS7-40047	TMS7-4030~TMS7-4110	TMS7-4132~TMS7-4800
110/460 VAC	995-00821-00	995-00823-00	995-00824-00
110/575 VAC	995-00825-00	995-00827-00	995-00828-00

Input Voltages (C45 Models)	Part Number		
	TMS7-4007~TMS7-4022	TMS7-4030~TMS7-4110	TMS7-4132~TMS7-4800
110/230 VAC	995-00829-00	995-00831-00	995-00832-00

**6.3 Control Wiring**

TMS7 operation can be controlled using either the local push buttons, remote control inputs or the serial communications link. The <LOCAL/REMOTE> push button can be used to switch between local and remote control. Refer to Function 20.

*Local/Remote Operation* for details.

**Remote Control Inputs**

The TMS7 has four remote control inputs. Contacts used for controlling these inputs should be low voltage, low current rated (Gold flash or similar).

Remote push button control

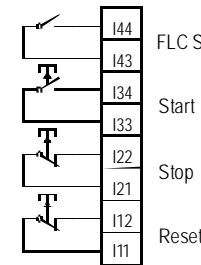

Two wire control

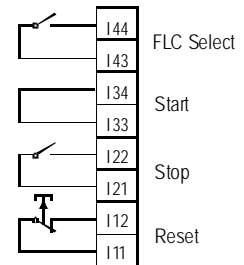

**CAUTION:**

Do not apply voltage to the control inputs. The inputs are active 24VDC and must be controlled with potential free circuits.

Ensure contacts/switches operating the control inputs are suitable for low voltage, low current switching ie, gold flash or similar.

Ensure cables to the control inputs are segregated from AC power and control wiring.

**Relay Outputs**

The TMS7 provides four relay outputs, one fixed and three programmable. Functionality of the programmable outputs is determined by the settings of Functions 21, 22 & 23.

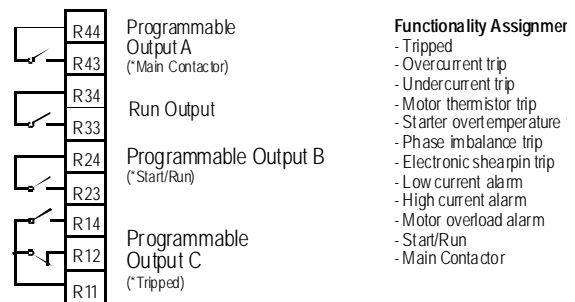

\* = default functionality

**Functionality Assignmer**

- Tripped
- Overcurrent trip
- Undercurrent trip
- Motor thermistor trip
- Starter overtemperature
- Phase imbalance trip
- Electronic shearpin trip
- Low current alarm
- High current alarm
- Motor overload alarm
- Start/Run
- Main Contactor

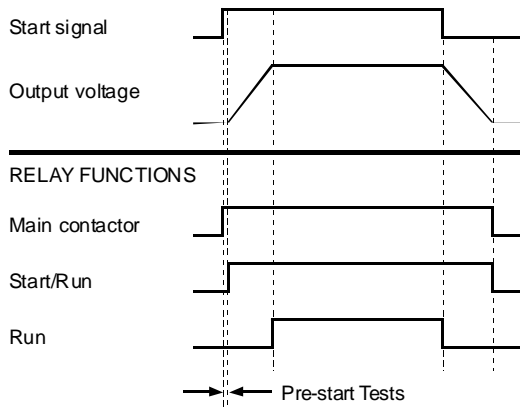

**Motor Thermistors**

Motor thermistors (if installed in the motor) may be connected directly to the TMS7. A trip will occur when the resistance of the thermistor circuit exceeds approximately 2.8kΩ. The TMS7 can be reset once the thermistor circuit resistance falls below approximately 2.8kΩ

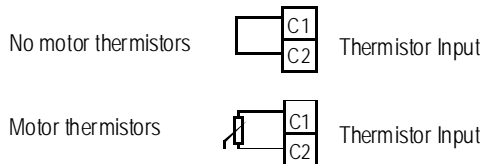

**NOTE:**

The thermistor circuit must be closed before the TMS7 will run.

The thermistor circuit should be run in screened cable and must be electrically isolated from earth and all other power and control circuits.

If no motor thermistors are connected to the TMS7 thermistor input there must be a link across the thermistor input terminals C1 & C2.

**6.4 RS485 Serial Communication**

The TMS7 has a non-isolated RS485 serial communication link.

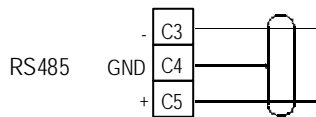

**NOTE:**

Power cabling should be kept at least 300mm away from communications cabling. Where this cannot be avoided magnetic shielding should be provided to reduce induced common mode voltages.

Data transmitted to and from the TMS7 must be in 8 bit ASCII, no parity, 1 stop bit.

Baud rate is set by Function. 61 *RS485 Baud Rate*.

The TMS7 can be programmed to trip if the RS485 link fails by setting Function 60. *RS485 Timeout*.

The starter address is assigned using Function 62. *RS485 Satellite Address*.

The flow charts below show typical form of communication between an TMS7 and host controller.

**Host controller to TMS7**

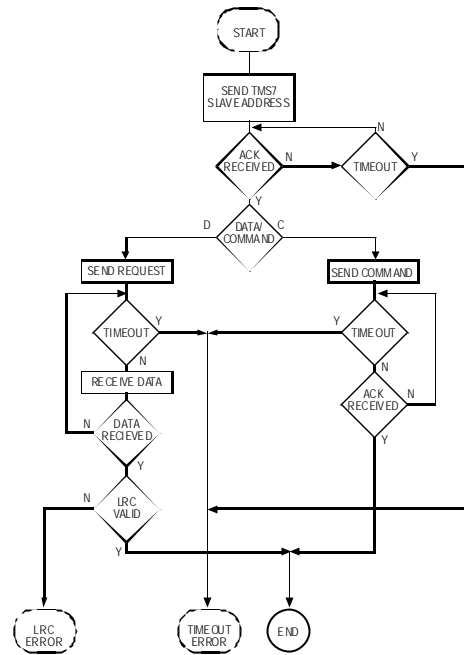

**TMS7 to host controller**

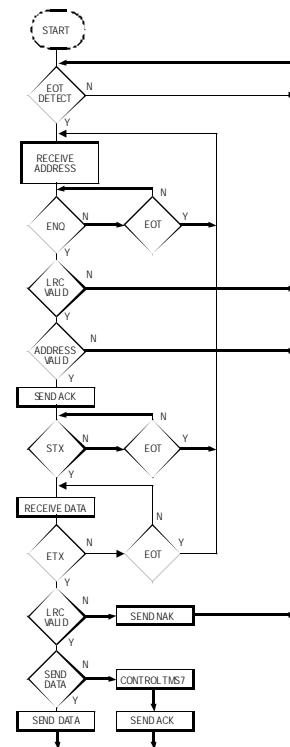

The following code sequences are used in the communications between the host and the TMS7 (network).

**Address slave unit.**

ASCII	EOT	[n]	LRC
or	04h	[n1]h [n2]h	[LRC1]h [LRC2]h
	05h		

**Slave response.**

ASCII	ACK
or	06h



**NOTE:**  
If no TMS7 starter is configured to the specific slave address, no response will be received by the host. The host software timeout should be set to a minimum of 250 ms.



**NOTE:**  
Slave address must be two digit, addresses less than 10 must have a leading zero (0).

Master command to slave.

ASCII	STX	[command]	LRC	ETX
or	02h	[c1]h [c2]h [c3]h	[LRC1]h [LRC2]h	03h

[command] = 3 byte ASCII command (or request) selected from the tables below.

LRC = Longitudinal Redundancy Check.

Slave response if Command and LRC correct

ASCII	ACK
or	06h

Slave response if Command and LRC incorrect

ASCII	NAK
or	15h

Slave response of Read request correct and LRC correct.

ASCII	STX	[data]	LRC
	ETX		
or	02h	[d3]h [d2]h [d1]h [d0]h	[LRC1]h [LRC2]h
	03h		

Slave response if Read request or LRC invalid.

ASCII	NAK
or	15h

Each command, status or data request is a 3 byte string as detailed below. Invalid command/request strings cause the TMS7 to respond with a NAK (15h).

Command	ASCII	Comment
Start	B10	Initiates a start.
Stop	B12	Initiates a stop
Reset	B14	Resets a trip state
Coast to stop	B16	Initiates an immediate removal of voltage from the motor. Any soft settings are ignored.

Status Read	ASCII	Comment
Status	C10	Requests the configuration status of the TMS7.
Status_1	C12	Requests the operational status of the TMS7.
Trip	C14	Requests the trip status of the TMS7.
Version	C16	RS485 protocol version number.
Trip Code	C18	255 = No trip 0 = Shorted SCR 1 = Reserved 2 = Motor Thermal model trip 3 = Motor thermistor 4 = Current imbalance trip 5 = Supply frequency trip

Status Read	ASCII	Comment
		6 = Phase rotation trip
		7 = Stall trip
		8 = Power circuit fault
		9 = Undercurrent trip
		10 = Starter heatsink overtemperature
		11 = Invalid motor connection

Data Read	ASCII	Comment
Current	D10	Requests motor current. The data is 4 byte decimal ASCII. Minimum value 0000, Maximum value 9999 Amps.
Temp	D12	Requests the calculated value of the motor thermal model as a % of Motor Thermal Capacity. The data is 4 byte decimal ASCII. Minimum value 0000%. Trip point 0105%.

Each command string sent to and from the TMS7 includes a check sum. The form used is the Longitudinal Redundancy Check (LRC) in ASCII hex. This is an 8-bit binary number represented and transmitted as two ASCII hexadecimal characters.

To calculate LRC:

1. Sum all ASCII bytes
2. Mod 256
3. 2's complement
4. ASCII convert

For example Command String (Start);

ASCII	STX	B	1	0
or	02h	42h	31h	30h

ASCII	Hex	Binary
STX	02h	0000 0010
B	42h	0100 0010
1	31h	0011 0001
0	30h	0011 0000
	A5h	1010 0101 SUM (1)
	A5h	1010 0101 MOD 256 (2)
	5Ah	0101 1010 1's COMPLEMENT
	01h	0101 1011 + 1 =
	5Bh	0101 1011 2's COMPLEMENT (3)

ASCII	5	B	ASCII CONVERT (4)
or	35h	42h	LRC CHECKSUM

The complete command string becomes

ASCII	STX	B	1	0	5	B	ETX
or	02h	42h	31h	30h	35h	42h	03h

To verify a received message containing an LRC;

1. Convert the last two bytes of message from ASCII to binary.
2. Left shift 2<sup>nd</sup> to last byte 4 bits.
3. Add this result to the last byte to get the binary LRC.
4. Add up all the bytes of the message, except the last two.
5. Add the binary LRC.
6. The least significant byte should be zero.

For example:

ASCII	STX	B	1	0	5	B
	ETX					

or            02h   42h   31h   30h   35h   42h  
                  03h

1.        35h (ASCII hex) = 5H = 0000101  
           42h (ASCII hex) = Bh = 0001011
- Note:   03h is the EXT character (end of transmission) and is not part of the message.
2.        0000101 = 0101000
3.        0101000 + 0000101 = 01011011
4.        02h + 42h + 31h + 30h = A5h
5.        A5h + 5Bh = 100h
6.        The least significant byte is zero so the message and LRC match.

Response or status bytes are sent from the TMS7 as an ASCII string.

STX   [d1]h   [d2]h   [d3]h   [d4]h   LRC1   LRC2   ETX  
 d1 =   30h  
 d2 =   30h  
 d3 =   30h plus upper nibble of status byte right shifted by four binary places.  
 d4 =   30h plus lower nibble of status byte.

For example status byte = 1Fh, response is  
 STX   30h   30h   31h   3Fh   LRC1   LRC2   ETX

Status bits (positive logic 1 = true)

Status Bit	Function	Comment
Status.7	50 Hz	Only one of either Status.7 or Status.6 can be at logic 1 when the TMS7 is operating.
Status.6	60 Hz	
Status.5	-	Unallocated
Status.4	Soft stop	
Status.3	Positive phase rotation	Will be at logic 0 when there is a negative phase rotation.
Status.2	-	Unallocated
Status.1	-	Unallocated
Status.0	-	Unallocated

Status\_1 bits (negative logic 0 = true)

Status Bit	Function	Comment
NOT Status_1.7	-	
NOT Status_1.6	-	
NOT Status_1.5	-	
NOT Status_1.4	Restart Delay	
NOT Status_1.3	Overload	Motor is operating in an overload condition.
NOT Status_1.2	Run	
NOT Status_1.1	Output On	
NOT Status_1.0	Power On	

Trip bits (negative logic 0 = true). The table below shows the complement of these bits to give positive logic (1 = true).

Status Bit	Function
NOT Trip.7	Phase Loss
NOT Trip.6	Undercurrent
NOT Trip.5	Phase Rotation
NOT Trip.4	Overcurrent
NOT Trip.3	Over Temperature
NOT Trip.2	Installation
NOT Trip.1	Stall Protection
NOT Trip.0	Thermistor



**Programming**

**7.1 Programming Procedure**

**Step 1. Enter program mode.**

1. Simultaneously press and release the <FUNCTION> and <STORE> keys. (When in program mode the three LEDs to the right of the numeric display will be illuminated.)



**Step 2. Select the function number to be viewed or adjusted.**

1. Press and hold the <FUNCTION> key.
2. Using the <UP> and <DOWN> keys select the required function number. (Function numbers are left justified and blink).
3. When the required function number is displayed, release the <FUNCTION> key. The display changes to show the function set point currently stored in memory. (Function values are right justified and do not blink)



**Step 3. Alter the function set point.**

1. Review the current function set point and, if necessary, use the <UP> or <DOWN> keys to adjust the setting. (Pressing the <FUNCTION> key will restore the original setting).



**Step 4. Store the new function set point.**

1. Press the <STORE> key to store the displayed setting into memory.
2. Verify the new set point has been correctly stored by pressing and then releasing the <FUNCTION> key. The LED display should now show the new set point.



**Step 5. Exit program mode.**

1. Once all function settings have been made, exit the programming mode by simultaneously pressing and releasing the <FUNCTION> and <STORE> keys.



7.2 Function List

No.	Function	Default Setting
<b>Primary Motor Settings</b>		
1	Motor full load current	-
2	Current limit	350
3	Minimum current	350
4	Start ramp time	1
5	Stop ramp time	0
6	Motor trip class	10
7	Current imbalance sensitivity	5
8	Undercurrent protection	20
9	Stall protection	400
<b>Start/Stop Formats</b>		
10	Soft stop mode	0
<b>Starter Functionality</b>		
20	Local/Remote operation	0
21	Relay output A functionality	11
22	Relay output B functionality	10
23	Relay output C functionality	0
<b>Protection Settings</b>		
30	Phase rotation	0
31	Restart delay	15
32	Current imbalance	0
<b>Set Points</b>		
40	Low current alarm	50
41	High current alarm	105
42	Motor temperature alarm	80
43	Field calibration	100
<b>Analogue Output (Motor Current - % FLC)</b>		
50	4-20mA output range - max	100
51	4-20mA output range - min	0
<b>Serial Communications</b>		
60	RS485 timeout	0
61	RS485 baud rate	4
62	RS485 satellite address	20
<b>Auto Reset</b>		
70	Auto-reset - configuration	0
71	Auto-reset - number of resets	1
72	Auto-reset - group A & B delay	5
73	Auto-reset - group C delay	5
<b>Secondary Motor Settings</b>		
80	Motor full load current	-
81	Current limit	350
82	Minimum current	350
83	Start ramp time	1
84	Stop ramp time	0
85	Motor trip class	10
86	Current imbalance sensitivity	5
87	Undercurrent protection	20
88	Stall protection	400
<b>Protection Delays</b>		
90	Current imbalance trip delay	3
<b>Read Only Data</b>		
100	Model Number	-
101	Fault History	-
<b>Restricted Functions</b>		
110	Access code	0
111	Update access code	0
112	Function lock	0
113	Restore function settings	0

7.3 Function Descriptions

1. Motor Full Load Current

Range: Model Dependant (Amps)

Default Setting: Model Dependant (Amps)

Description: Sets the TMS7 for the connected motor's full load current.

Adjustment: Set to the Full Load Current (amps) rating shown on the motor nameplate.

2. Current Limit

Range: 100 – 550 % FLC

Default Setting: 350% FLC

Description: Sets the current limit for the Constant Current start mode.

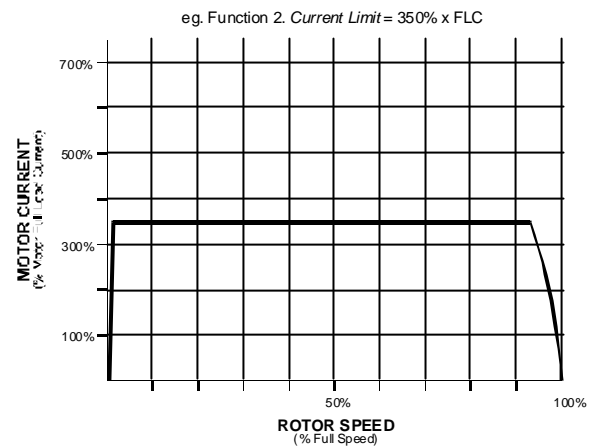

Adjustment: The required setting for the Current Limit function is installation dependant and should be set such that:

- The motor is supplied with sufficient start current to enable it to produce torque adequate to easily accelerate the connected load.
- Desired starting performance is obtained.
- TMS7 ratings are not exceeded.

3. Minimum Current

Range: 100 – 550 % FLC

Default Setting: 350% FLC

Description: Sets the minimum current level for the Ramp Start mode.

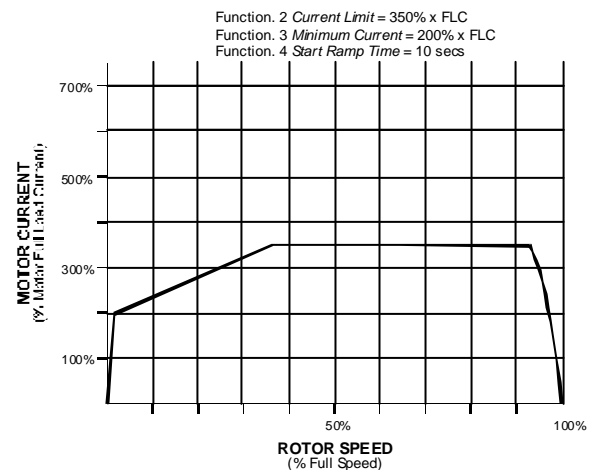

**Adjustment:** Function 3 *Minimum Current* and Function 4 *Start Ramp Time* are used together to activate and control the Ramp Start mode.

If the Ramp Start mode is required, set the *Minimum Current* so that the motor begins to accelerate immediately a start is initiated. Ramp Start mode is not required, set the *Minimum Current* equal to the Current Limit.

Ramp Start mode should be considered in preference to Current Limit start mode in applications where:

- Required start torque can vary from start to start. For example conveyors may start loaded or unloaded. In this case set Function 3 *Minimum Current* to a level that will start motor in the light load condition and Function 2 *Current Limit* to a level that will start the motor in the high load condition.
- Starting time of an easily broken away load needs to be extended, for example pumps.
- A generator set supply is limited and a slower application of load will allow greater time for the generator set to respond.

#### 4. Start Ramp Time

**Range:** 1 – 30 Seconds

**Default Setting:** 1 Second

**Description:** Sets the ramp time for the Current Ramp start mode.

**Adjustment:** Set the *Start Ramp Time* to optimise start performance.

#### 5. Stop Ramp Time

**Range:** 0 – 100 Seconds

**Default Setting:** 0 Second (Off)

**Description:** Sets the soft stop ramp time for soft stopping of the motor.

**Adjustment:** Set the *Stop Ramp Time* to produce the desired motor stopping performance.

Two soft stop modes are provided by the TMS7. Use Function 10. *Soft Stop Mode* to select the desired mode.

If utilising the Soft Stop function and a line contactor, the contactor must not be opened until the end of the stop ramp time. The TMS7 programmable outputs A,B or C can be set for control of the line contactor. Refer Functions 21, 22, 23 for programmable output assignment details.

#### 6. Motor Trip Class

**Range:** 0 – 60 Seconds

**Default Setting:** 10 Seconds



**NOTE:** A setting of 0 seconds disables the TMS7 motor thermal model. Use this setting only if another form of motor protection is used.

**Description:** Sets the motor thermal capacity used by the TMS7 motor thermal model.

**Adjustment:** Set the Motor Trip Class (MTC) according to the motor's thermal capacity.

A motor's thermal capacity is expressed as the maximum time (seconds) a motor can maintain locked rotor conditions from cold, and is often referred to as Maximum Locked Rotor

Time or Maximum DOL Start Time. This information is available from the motor data sheet or direct from the motor supplier.



**NOTE:** The TMS7 motor thermal model assumes a locked rotor current of 600%. If the connected motor's locked rotor current differs from this, greater accuracy can be achieved by using a normalised MTC figure. A normalised MTC figure can be calculated as follows:

$$MTC = \left( \frac{\%LRC}{600} \right)^2 \times \text{Max Start Time}$$



**NOTE:** Setting Function 6 *Motor Trip Class* according to the motor's actual thermal capacity allows safe use of the motor's full overload capability both to start the load and ride through overload conditions. Additionally, a more conservative approach can be taken by setting a reduced MTC for easy to start loads that will not experience transient operating overloads as a part of normal operation.

Using a reduced MTC figure has the advantage of maximising motor life. The life of a motor is strongly influenced by its maximum winding temperature, with a 'rule of thumb' stating that the expected life span of a motor is halved for every ten degree rise in temperature. The temperature rise is dependent on the motor losses and the motor cooling. The highest stress on the motor is during start, and can be minimised by restricting the duration and frequency of starts. A reduced MTC setting (Function 6) will also cause the TMS7 protection to operate before the motor is thermally stressed.

A suitable reduced MTC figure can be established by observing the modeled motor temperature as shown on the TMS7 LED display, and adjusting the MTC parameter such that after a normal start which has been preceded by a period of running at maximum load, the calculated motor temperature is approaching 90%.

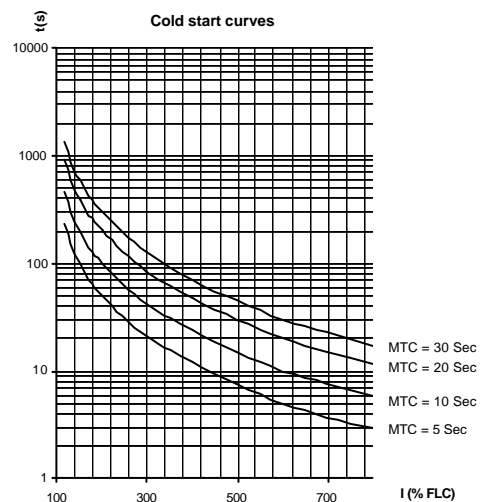

**7. Current Imbalance Sensitivity**

Range: 1 – 10  
 1 = Highest sensitivity (lowest imbalance)  
 |  
 5 = Average sensitivity  
 |  
 10 = Lowest sensitivity (highest imbalance)

**Default Setting:** 5  
**Description:** Sets the sensitivity of the current imbalance protection.  
**Adjustment:** The factory setting is suitable for most applications however the sensitivity can be adjusted to accommodate site specific tolerances

**8. Undercurrent Protection**

Range: 15% – 100% FLC  
**Default Setting:** 20% FLC  
**Description:** Sets the trip point for the TMS7 undercurrent protection as a percentage of motor full load current.  
**Adjustment:** Set to a level below the motors normal working range and above the motor's magnetising (no load) current. To disable the undercurrent protection make a setting less than the magnetising current of the motor, typically 25% - 35% of rated Full Load Current.



**NOTE:**  
 Undercurrent protection is only operative during 'run'.

**9. Stall Protection**

Range: 80% – 550% FLC  
**Default Setting:** 400% FLC  
**Description:** Sets the trip point for the TMS7 stall protection as a percentage of motor full load current.  
**Adjustment:** Set as required.



**NOTE:**  
 Stall protection is operative only during 'run'.

**10. Soft Stop Mode**

Range: 0 – 1  
 0 = Standard soft stop  
 1 = Pump control  
**Default Setting:** 0 (Standard soft stop)  
**Description:** Sets the active soft stop mode.  
**Adjustment:** The standard soft stop mode automatically monitors motor deceleration and will provide optimum control for most applications. Pump control may however offer superior performance in some applications and can be of particular benefit in some pumping applications.

**20. Local/Remote Operation**

Range: 0 – 3  
 0 = TMS7 Local/Remote push button always enabled.

- 1 = TMS7 Local/Remote push button disabled while motor running.
- 2 = Local control only. (TMS7 push buttons enabled, remote inputs disabled)
- 3 = Remote control only. (TMS7 push buttons disabled, remote inputs enabled)

**Default Setting:** 0 (Local/Remote button enabled)  
**Description:** Enables and disables the local push buttons and remote control inputs. Also determines when and if the Local/Remote push button can be used to switch between local and remote control.  
**Adjustment:** Set as required

**21. Relay Output A Functionality**

- Range: 0 – 11
- 0 = Tripped
  - 1 = Overcurrent trip
  - 2 = Undercurrent trip
  - 3 = Motor thermistor trip
  - 4 = Starter overtemperature trip
  - 5 = Phase imbalance trip
  - 6 = Electronic shearpin trip
  - 7 = Low current alarm
  - 8 = High current alarm
  - 9 = Motor overload alarm
  - 10 = Start/Run
  - 11 = Main contactor.

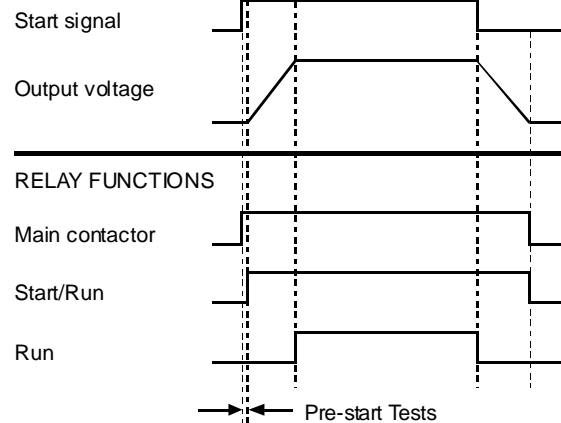

**Default Setting:** 11 (Main Contactor)  
**Description:** Assigns the functionality of programmable relay output A.  
**Adjustment:** Set as required

**22. Relay Output B Functionality**

Range: 0 - 11  
**Default Setting:** 10 (Start/Run)  
**Description:** Assigns the functionality of programmable relay output B.  
**Adjustment:** Refer Function 21 *Relay Output A Functionality* for adjustment detail.

**23. Relay Output C Functionality**

Range: 0 - 11  
**Default Setting:** 0 (Tripped)  
**Description:** Assigns the functionality of programmable relay output C.

**Adjustment:** Refer Function 21 *Relay Output A Functionality* for adjustment detail.

**30. Phase Rotation**

**Range:** 0 – 2  
 0 = Off (forward and reverse rotation accepted)  
 1 = Forward rotation only (reverse rotation prohibited)  
 2 = Reverse rotation only (forward rotation prohibited)  
**Default Setting:** 0 (Off)

**Description:** Sets the valid phase rotations for the TMS7 phase rotation protection. The TMS7 examines the incoming three phases and trips if phase rotation does not match the allowable rotations specified by Function 30.

**Adjustment:** Set as required.

**31. Restart Delay**

**Range:** 1 – 254 seconds  
**Default Setting:** 15 Second

**Description:** Sets the minimum time between the end of a stop and the beginning of the next start.

**Adjustment:** Set as required. During the restart delay period the LEDs to the right of the TMS7 LED display will flash indicating the motor cannot yet be restarted.

**32. Current Imbalance**

**Range:** 0 – 1  
 0 = On  
 1 = Off  
**Default Setting:** 0 (On)

**Description:** Enables or disables the phase imbalance protection.

**Adjustment:** Set as required.

**40. Low Current Alarm**

**Range:** 1 – 100% FLC  
**Default Setting:** 50% FLC

**Description:** Sets the current level (% FLC) at which the low current alarm operates.

**Adjustment:** The low current alarm can be assigned to the Programmable Relay Outputs A, B or C for indication of a motor current lower than the programmed value.

**41. High Current Alarm**

**Range:** 50 – 550% FLC  
**Default Setting:** 105% FLC

**Description:** Sets the current level (% FLC) at which the high current alarm operates.

**Adjustment:** The high current alarm can be assigned to the Programmable Relay Outputs A, B or C for indication of a motor current in excess of the programmed value.

**42. Motor Temperature Alarm**

**Range:** 0 – 105% Motor Temperature  
**Default Setting:** 80%

**Description:** Sets the temperature (%) at which the motor overtemperature alarm operates.

**Adjustment:** The motor overtemperature alarm can be assigned to the Programmable Relay Outputs A, B or C for indication of a motor temperature (as calculated by the Motor Thermal Model) in excess of the programmed value.

A trip condition occurs when motor temperature reaches 105%.

**43. Field Calibration**

**Range:** 85% - 115%  
**Default Setting:** 100%

**Description:** Adds a gain to the TMS7 current monitoring circuits. The TMS7 is factory calibrated with an accuracy of ± 5%. The field calibration function can be used to match the TMS7 current readout with an external current metering device.

**Adjustment:** Use the following formula to calculate the setting required.

$$\text{Field Calibration (Function 43)} = \frac{\text{Current shown on TMS7 display}}{\text{Current measured by external device}}$$

e.g. 96% =  $\frac{108 \text{ Amps}}{112 \text{ Amps}}$



**NOTE:**  
 All current based functions are affected by this adjustment.

**50. 4-20mA Output Range - Max**

**Range:** 0 – 255%  
**Default Setting:** 100 %

**Description:** Determines the value represented by a 20mA signal from the analogue output.

**Adjustment:** Set as required to show percentage of motor current.

**51. 4-20mA Output Range - Min**

**Range:** 0 – 255%  
**Default Setting:** 0 %

**Description:** Determines the value represented by a 4mA signal from the analogue output.

**Adjustment:** Set as required to show percentage of motor current.

**60. RS485 Timeout**

**Range:** 0 – 100 Seconds  
**Default Setting:** 0 seconds (Off)

**Description:** Sets the maximum allowable period of RS485 serial inactivity.

**Adjustment:** Set as required.



**NOTE:**  
 A setting of 0 seconds disables the RS485 – Timeout Protection and enables the TMS7 to continuing operating even if the RS485 link becomes inactive.

**61. RS485 Baud Rate**

Range: 1 – 5

1 = 1200 baud

2 = 2400 baud

3 = 4800 baud

4 = 9600 baud

5 = 19200 baud

Default Setting: 4 (9600 baud)

Description: Sets the baud rate for RS485 serial activity.

Adjustment: Set as required.

**62. RS485 Satellite Address**

Range: 1 - 99

Default Setting: 20

Description: Assigns the TMS7 an address for RS485 serial communication.

Adjustment: Set as required.

**70. Auto-Reset - Configuration**

Range: 0 – 3

0 = Off

1 = Reset Group A trips

2 = Reset Group A & B trips

3 = Reset Group A, B & C trips

Default Setting: 0 (Off)

Description: Determines which trips will be automatically reset.

Adjustment: A setting of other than 0 causes the TMS7 to automatically reset, and after a delay if the start signal is still present, attempt to start the motor. The Auto-reset function can be programmed to reset faults according to the table below:

Trip Group	Trip Conditions
A	Phase imbalance, Phase loss
B	Undercurrent, Electronic shearpin
C	Overcurrent, Motor thermistor, Starter overtemperature

Operation of the Auto-reset function is controlled according to the following function settings:

Function 70. *Auto-reset – Configuration*

Function 71. *Auto-reset – Number of resets*

Function 72. *Auto-reset – Group A & B Delay*

Function 73. *Auto-reset – Group C Delay*



**CAUTION:**

Operation of the auto-reset function will reset a trip state and if the start signal is still present, allow the motor to restart. Ensure that personal safety is not endangered by such operation and that all relevant safety measures and/or regulations are complied with before utilising this function.

**71. Auto-Reset – Number Of Resets**

Range: 1 - 5

Default Setting: 1

Description: Sets maximum number of reset attempts for the Auto-reset function.

Adjustment: The Auto-reset counter increases by one after each trip, up to the maximum number of resets set in Function 71. *Auto-Reset – Number Of Resets*. The fault is then latched and a manual reset is required.

The Auto-reset counter decreases by one, to a minimum of zero, after each successful start/stop cycle.

Refer Function 70 *Auto-Reset – Configuration* for further detail.

**72. Auto-Reset – Group A & B Delay**

Range: 5 – 999 seconds

Default Setting: 5 seconds

Description: Sets the delay for resetting of Group A & B trips.

Adjustment: Refer Function 70 *Auto-Reset – Configuration* for further detail.

**73. Auto-Reset – Group C Delay**

Range: 5 – 60 minutes

Default Setting: 5 minutes

Description: Sets the delay for resetting of Group C trips.

Adjustment: Refer Function 70 *Auto-Reset – Configuration* for further detail.

TMS7 soft starters can be programmed with two separate sets of motor data. The primary motor settings are adjusted using Functions 1 – 9. The secondary motor settings are adjusted using Functions 80 – 88.

When commanded to start the TMS7 checks the state of the FLC Select input (Terminals I43 & I44). In the event of an open circuit the primary motor settings are used. In the event of a closed circuit the secondary motor settings are used.

**80. Motor Full Load Current**

Range: Model Dependant (Amps)

Default Setting: Model Dependant (Amps)

Description: Sets the TMS7 for the connected motor's full load current.

Adjustment: Refer to Function 1 for further detail.

**81. Current Limit**

Range: 100 – 550 % FLC

Default Setting: 350% FLC

Description: Sets the current limit for the Constant Current start mode.

Adjustment: Refer to Function 2 for further detail.

**82. Minimum Current**

Range: 100 – 550 % FLC

Default Setting: 350% FLC

Description: Sets the minimum current level for the Ramp Start mode.

Adjustment: Refer to Function 3 for further detail.

**83. Start Ramp Time**

**Range:** 1 – 30 Seconds  
**Default Setting:** 1 Second  
**Description:** Sets the ramp time for the Current Ramp start mode.  
**Adjustment:** Refer to Function 4 for further detail.

**84. Stop Ramp Time**

**Range:** 0 – 100 Seconds  
**Default Setting:** 0 Second (Off)  
**Description:** Sets the soft stop ramp time for soft stopping of the motor.  
**Adjustment:** Refer to Function 5 for further detail.

**85. Motor Trip Class**

**Range:** 0 – 60 Seconds  
**Default Setting:** 10 Seconds



**NOTE:**  
 A setting of 0 seconds disables the TMS7 motor thermal model. Use this setting only if another form of motor protection is used.

**Description:** Sets the motor thermal capacity used by the TMS7 motor thermal model.  
**Adjustment:** Refer to Function 6 for further detail.

**86. Current Imbalance Sensitivity**

**Range:** 1 – 10  
 1 = Highest sensitivity (lowest imbalance)  
           |  
           5 = Average sensitivity  
           |  
 10 = Lowest sensitivity (highest imbalance)

**Default Setting:** 5  
**Description:** Sets the sensitivity of the current imbalance protection.  
**Adjustment:** Refer to Function 7 for further detail.

**87. Undercurrent Protection**

**Range:** 15% – 100% FLC  
**Default Setting:** 20% FLC  
**Description:** Sets the trip point for the TMS7 undercurrent protection as a percentage of motor full load current.  
**Adjustment:** Refer to Function 8 for further detail.

**88. Stall Protection**

**Range:** 80% – 550% FLC  
**Default Setting:** 400% FLC  
**Description:** Sets the trip point for the TMS7 stall protection as a percentage of motor full load current.  
**Adjustment:** Refer to Function 9 for further detail.

**90. Current Imbalance Trip Delay**

**Range:** 3 – 254 Seconds

**Default Setting:** 3 Seconds  
**Description:** Sets the delay period between detection of a phase imbalance greater than allowed by the setting made in Function 7 & 86. *Current Imbalance Sensitivity* and a trip condition.  
**Adjustment:** Set as required.

**100. Model Number**

**Range:** 1 - 22  
**Default Setting:** Model Dependant  
**Description:** A diagnostic parameter used to identify the power assembly type.

**101. Fault History**

**Range:** n/a  
**Default Setting:** n/a  
**Description:** Displays the TMS7 Fault History.  
**Adjustment:** Use the <UP> and <DOWN> keys to scroll through the trip log.  
 Refer to Section 9, Trouble Shooting Procedure for a description of the trip log and fault conditions.

**110. Password**

**Range:** 0 - 999  
**Default Setting:** 0  
**Description:** Entering the correct password does two things  
 1. Temporarily changes the function lock to Read/Write irrespective of the state specified by Function 112 *Function Lock*. This allows function settings to be adjusted during the current programming session. On exit of the current programming session function settings are again protected according to Function 112. *Function Lock*.  
 2. Provides access to parameters 111 - 113.  
**Adjustment:** Enter password. The default password is 0. Contact your supplier if the password is lost or forgotten

**111. Update Password**

**Range:** 0 - 999  
**Default Setting:** 0  
**Description:** Changes the current password.  
**Adjustment:** Set as required, remembering to make note of the new password.

**112. Function Lock**

**Range:** 0 – 1  
 0 = Read/Write  
 1 = Read Only  
**Default Setting:** 0 (Read / Write)  
**Description:** Allows protection of all function settings. Note that when this function has been changed from 0 (Read/Write) to 1 (Read Only) the new setting takes effect only when program mode is exited.  
**Adjustment:** Set as required.

**113. Restore Function Settings**

**Range:** 0, 50

**Default Setting:** 0

**Description:** Allows function adjustments be returned to the factory defaults.

**Adjustment:** Set to 50 to load default parameter settings.

### 7.4 Operation

Once installed, wired and programmed according to the instructions earlier in this manual the TMS7 can be operated.

#### Local control panel.

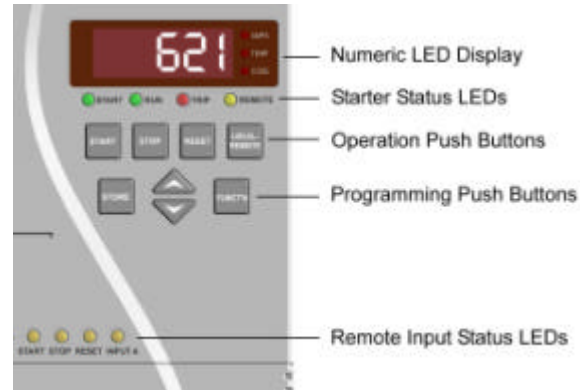

1. **Numeric LED Display:** The information being displayed is indicated by the LEDs to the right of the display. During operation either motor current (Amps) or the calculated motor temperature (%) can be displayed. Use the <UP> or <DOWN> keys select what information is displayed. In the event of a trip state the relevant trip code will be shown. If motor current exceeds the maximum current able to be shown on the numeric display, the display will show dashes. ---
2. **Starter Status LEDs:**  
 Start: Voltage is being applied to the motor terminals.  
 Run: Full voltage is being applied to the motor terminals.  
 Trip: The TMS7 has tripped.  
 Remote: The TMS7 is in remote control mode.

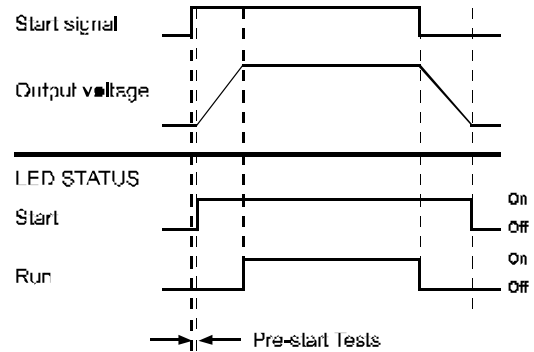

3. **Operational Push Buttons:** These push buttons can be used to control TMS7 operation when in local control mode. The <LOCAL/REMOTE> push button can be used to switch between local and remote control.



**NOTE:**

When control power is applied to the TMS7 it may be in either local or remote control mode according to the mode it was in when control power was removed. The factory default is local control.





**NOTE:**  
Function 20. *Local/Remote Operation* can be used to limit operation to either local or remote mode operation. If the <LOCAL/REMOTE> push button is used in an attempt to switch to a prohibited mode the numeric display will show 'OFF'.



**NOTE:**  
Simultaneously pressing the <STOP> and <RESET> push buttons causes the TMS7 to immediately remove voltage from the motor, resulting in a coast to stop. Any soft settings are ignored.

- 4. *Programming Buttons:* Refer to section 7.1.
- 5. *Remote Control Inputs Status:* These LEDs indicate the state of the circuits across the TMS7 remote control inputs.



**NOTE:**  
All LEDs and the Numeric display are illuminated for approximately 1 second to test their operation when control power is first applied.

**Remote control.**

TMS7 operation can be controlled via the remote control inputs when the soft starter is in remote mode. Use the <LOCAL/REMOTE> push button to switch between local and remote modes. Refer to section 6.3 *Control Wiring* for further detail.

**Restart delay.**

Function 31. *Restart Delay* sets the delay period between the end of a stop and the beginning of the next start. During the restart delay period the LEDs to the right of the numeric display will flash indicating that a restart cannot yet be attempted.

**Pre-start tests.**

Before applying voltage to the motor when a start is initiated, the TMS7 first performs a series of tests to check the motor connection and supply conditions.

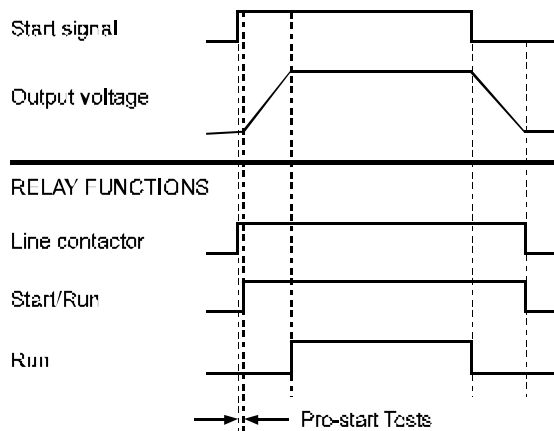

**Secondary motor settings.**

TMS7 starters can be programmed with two motor parameter sets. The primary motor parameters are set using functions 1-9. The secondary motor parameters are set using functions 80-88. When commanded to start the TMS7 checks the state of the FLC Select input (Terminals I43 & I44). In the event of an open

circuit the primary motor settings are used. In the event of a closed circuit the secondary motor settings are used.

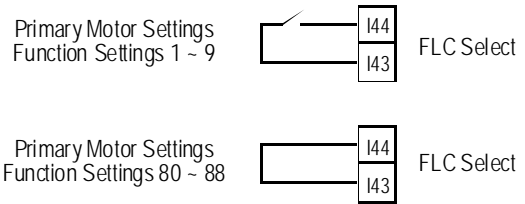

Application Examples

8.1 Installation With Line Contactor

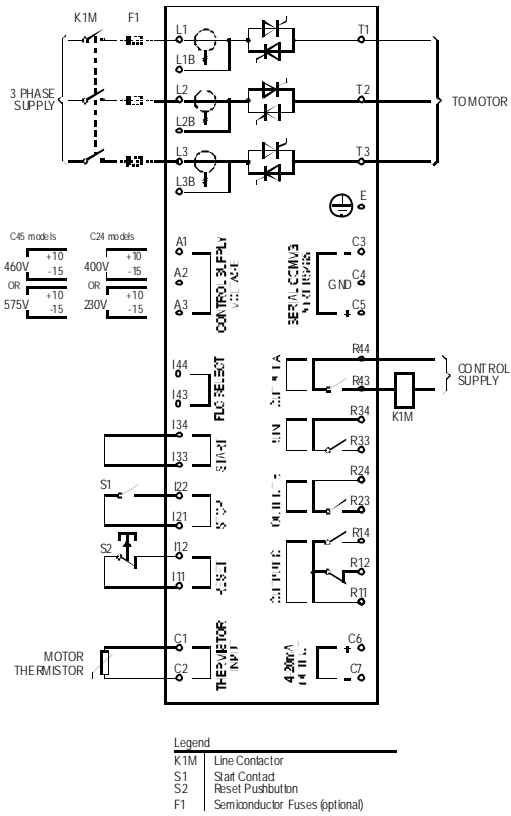

Description:

The TMS7 is applied with a line contactor (AC3 rated). The line contactor is controlled by the TMS7 Main Contactor output, which by default is assigned to RELAY OUTPUT A (terminals R44, R43). The control supply must be sourced from before the contactor.

Function Settings:

- Function 21. *Relay Output A Functionality* = 11 (Assigns the Main Contactor function to Relay Output A)

8.2 Installation With Bypass Contactor

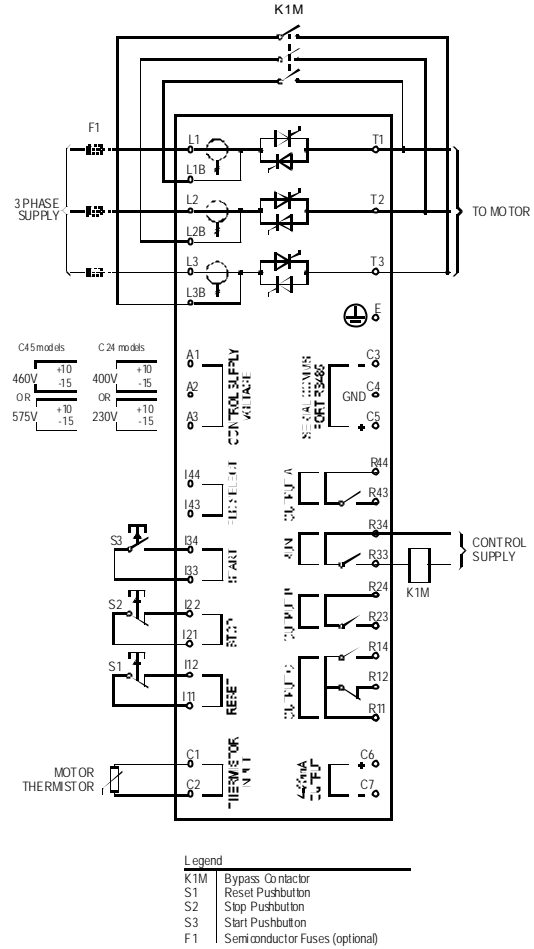

Description:

The TMS7 is applied with a bypass contactor (AC1 rated). The bypass contactor is controlled by the TMS7 RUN OUTPUT (terminals R34, R33).

Function Settings:

- no special settings required.

8.3 Soft Braking

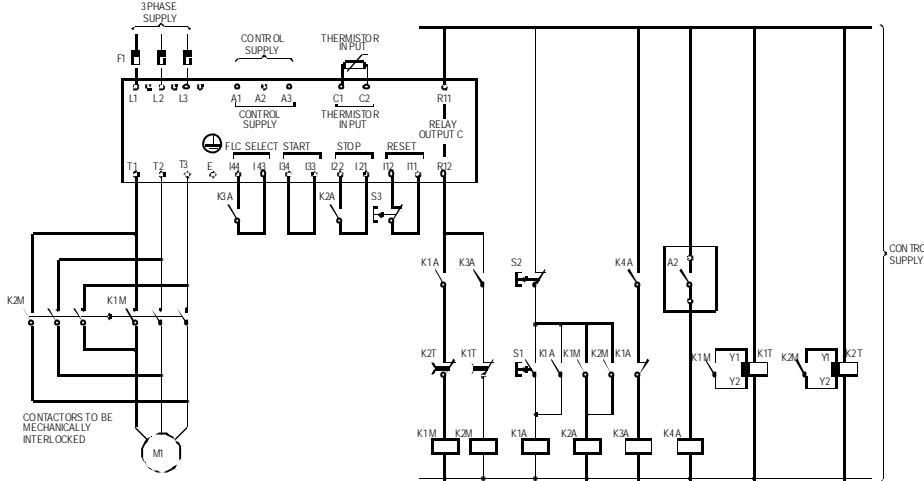

LEGEND

A2	SHAFT ROTATION SENSOR	K1M	LINE CONTACTOR (RUN)
F1	SEMICONDUCTOR FUSES (OPTIONAL)	K2M	LINE CONTACTOR (BRAKE)
K1A	RUN RELAY	K1T	RUN DELAY TIMER
K2A	START RELAY	K2T	BRAKE DELAY TIMER
K3A	BRAKE RELAY	S1	START PUSHBUTTON
K4A	ROTATION SENSING RELAY	S2	STOP PUSHBUTTON
		S3	RESET PUSHBUTTON

**Description:**

For high inertia loads that require more braking torque than is available from the D.C.Brake feature, the TMS7 can be configured for 'Soft Braking'.

In this application the TMS7 is employed with forward run and braking contactors. On receipt of a start signal (pushbutton S1) the TMS7 closes the forward run contactor (K1M) and controls the motor according to the programmed Primary Motor Settings.

On receipt of a stop signal (pushbutton S2) the TMS7 opens the forward run contactor (K1M) and closes the braking contactor (K2M) after a delay of approximately 2-3 seconds (K1T). K3A is also closed to activate the Secondary Motor Settings which should be user programmed for the desired stopping performance characteristics.

When motor speed approaches zero the shaft rotation sensor (A2) stops the soft starter and opens the braking contactor (K2M).

**Function Settings:**

- Function 23. *Relay Output C Functionality* = 0 (Assigns the Trip function to Relay Output C)
- Functions 1-9 (Sets starting performance characteristics)
- Functions 80-88 (Sets braking performance characteristics)

8.4 Two Speed Motors

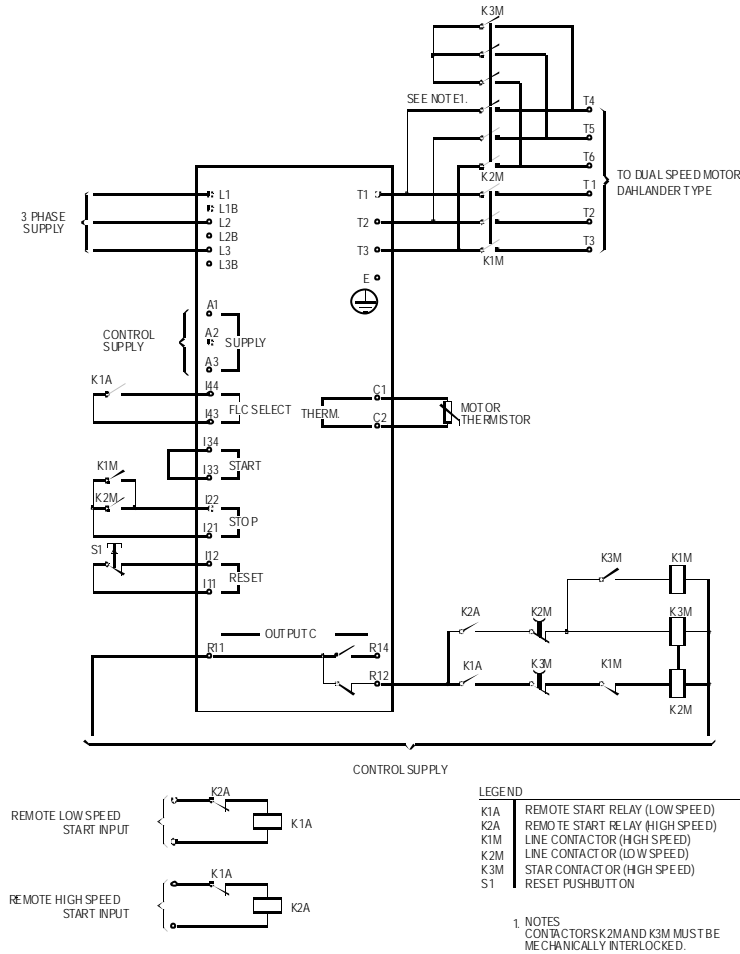

**Description:**

The TMS7 can be configured for control of dual speed Dahlander type motors. In this application the TMS7 is employed with a High Speed contactor (K1M), Low Speed contactor (K2M) and a Star contactor (K3M).

On receipt of a High Speed start signal the High Speed contactor (K1M) and Star contactor (K3M) are closed. The TMS7 then controls the motor according to the Primary Motor Parameter set. (Function Numbers 1-9)

On receipt of a Low Speed start signal the Low Speed contactor (K2M) is closed. The relay contact across Input A is also closed causing the TMS7 to control the motor according to the Secondary Parameter set (Function Numbers 80-88).

**Function Settings:**

- Function 23. *Relay Output C Functionality* = 0 (Assigns the Trip function to Relay Output C)

**Section 9 Trouble Shooting**

**9.1 Trip Codes**

When the TMS7 enters the trip state the cause of the trip is indicated on the LED display panel.

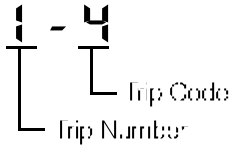

Code	Description
<b>0</b>	<p><b>Shorted SCR</b></p> <p>The TMS7 has detected a shorted SCR(s).</p> <ol style="list-style-type: none"> <li>Determine the affected phase using the 3 phase indicators LEDs located on the left hand side of the TMS7 cover. Damaged SCRs are indicated by an extinguished phase indicator LED (all phase indicator LEDs should be illuminated when input voltage is present but the motor is not running). SCR damage can be verified using the Power Circuit Test described in the Test &amp; Measurement chapter of this section.</li> <li>Replace the damaged SCR.</li> <li>Reset the trip condition by removing and reapplying control voltage to the TMS7.</li> </ol>
<b>2</b>	<p><b>Overcurrent trip</b></p> <p>The motor has been overloaded and the motor's thermal limit, as calculated by the TMS7 motor thermal model, has been reached.</p> <ol style="list-style-type: none"> <li>Remove the cause of the overload and let the motor cool before restarting.</li> </ol>
<b>3</b>	<p><b>Motor thermistor trip</b></p> <p>The motor thermistors have indicated an overtemperature situation.</p> <ol style="list-style-type: none"> <li>Identify and correct the cause of the motor overheating.</li> <li>If no thermistors are connected to the TMS7, ensure there is a closed circuit across the motor thermistor input (terminals C1 &amp; C2).</li> </ol>
<b>4</b>	<p><b>Current imbalance trip</b></p> <p>An imbalance in the phase currents has exceeded the limits set in Function 7. <i>Current Imbalance Sensitivity</i>.</p> <ol style="list-style-type: none"> <li>Monitor the supply voltage</li> <li>Check the motor circuit</li> </ol>
<b>5</b>	<p><b>Supply frequency trip</b></p> <p>Supply frequency has varied outside the TMS7's specified range.</p> <ol style="list-style-type: none"> <li>Correct the cause of the frequency variations.</li> <li>Check the three phase supply to the TMS7. Loss of all three phases is seen by the TMS7 as a 0Hz situation and may be the cause of a supply frequency trip.</li> <li>Check the three phase supply to the TMS7 is connected to input terminals L1, L2, L3. Incorrect connection of the incoming supply to the output terminals T1, T2, T3 means there is no supply</li> </ol>

Code	Description
	connected to the TMS7 input. This will be seen as a 0Hz situation and may be the cause of a supply frequency trip.
<b>6</b>	<p><b>Phase rotation trip</b></p> <p>The TMS7 has detected a phase rotation that has been prohibited by the setting made in Function 30. <i>Phase Rotation Protection</i>.</p> <ol style="list-style-type: none"> <li>Change the incoming phase rotation.</li> </ol>
<b>7</b>	<p><b>Stall trip</b></p> <p>The TMS7 has measured a current equal to the limit set in Function 9. <i>Stall Protection</i>.</p> <ol style="list-style-type: none"> <li>Identify and correct the cause of the instantaneous overload event.</li> </ol>
<b>8</b>	<p><b>Power circuit fault</b></p> <p>The TMS7 has detected a fault in the power circuit.</p> <ol style="list-style-type: none"> <li>Ensure that the motor is correctly connected to the TMS7 and verify the circuit.</li> <li>Check that voltage is correctly applied to all three TMS7 input terminals (L1, L2 &amp; L3).</li> </ol>
<b>9</b>	<p><b>Undercurrent trip</b></p> <p>The TMS7 has measured a run current lower than the limit set in Function 8. <i>Undercurrent Protection</i>.</p> <ol style="list-style-type: none"> <li>Identify and correct the cause of the undercurrent event.</li> </ol>
<b>F</b>	<p><b>Heatsink overtemperature trip</b></p> <p>The TMS7 heatsink temperature sensor has indicated and excess heatsink temperature.</p> <ol style="list-style-type: none"> <li>Verify that the TMS7 has sufficient ventilation.</li> <li>Verify that cooling air is able to freely circulate through the TMS7.</li> <li>Verify that the TMS7 cooling fans (if fitted) are working.</li> </ol>
<b>P</b>	<p><b>Invalid motor connection</b></p> <p>The TMS7 cannot detect a valid motor circuit.</p> <ol style="list-style-type: none"> <li>Ensure the motor is connected to the TMS7 in a valid configuration. Refer to Section 5 Power Circuits for further detail.</li> </ol>
<b>C</b>	<p><b>RS485 communication fault</b></p> <p>The RS485 link connected to the TMS7 has been inactive for a period of time greater than set in Function 60. <i>RS485 – Timeout Protection</i>.</p> <ol style="list-style-type: none"> <li>Restore the RS485 link.</li> </ol>
<b>E</b>	<p><b>EEPROM read/write failure</b></p> <p>The TMS7 has failed to read or write to the internal EEPROM.</p> <p>Reset the TMS7. If the problem persists contact your supplier.</p>
<b>L</b>	<p><b>Out of range FLC</b></p> <p>The TMS7 has detected that the motor is connected in the 3 Wire configuration and that Function 1. <i>Motor FLC</i> or Function 80 <i>Motor FLC</i> (secondary motor settings) has been set in excess of the TMS7's maximum capability for this connection format.</p> <ol style="list-style-type: none"> <li>Reduce the motor FLC setting and then reset the TMS7. Note that the TMS7 cannot be reset until the FLC setting has been corrected.</li> <li>Alternatively, remove control voltage from the</li> </ol>



Symptom	Cause
Erratic motor operation and tripping.	<b>SCRs not latching.</b> SCRs require a minimum current flow to 'latch' on. In situations where very small motors are being controlled by large soft starters the current drawn may be insufficient to latch on the SCRs. Increase motor size or reduce soft start size.
Soft stop ends before the programmed ramp time.	<b>Motor will not stall.</b> The TMS7 has significantly reduced the voltage applied to the motor without detecting a reduction in motor speed. This indicates that with present motor loading further control of the voltage will be ineffectual, hence the soft stop function has halted.
TMS7 display shows a 'h'	<b>The START button on the local control panel is stuck.</b> Release the button to restore normal operation.
TMS7 will not enter the programming mode.	<b>The TMS7 is running.</b> The TMS7 must be stopped before programming mode can be accessed.  <b>No, or incorrect control voltage.</b> Ensure the correct control voltage is applied to the inputs A1, A2, A3.

Test	Procedure
	2. Remove the motor cables from the output terminals of the TMS7 (T1, T2 & T3).
	3. Use a 500 VDC insulation tester to measure the resistance between the input and output of each phase of the TMS7 (L1-T1, L2-T2, L3-T3). Note that low voltage ohm meters or multi-meters are not adequate for this measurement.
	4. The measured resistance should be close to 33kΩ and approximately equal on all three phases.
	5. If a resistance of less than about 10kΩ is measured across the SCR, the SCR should be replaced.
	6. If a resistance greater than about 60kΩ is measured across the SCR there could be a fault with the TMS7 control module or firing loom.

9.4 Tests & Measurements

Test	Procedure
Run performance test.	This test verifies correct operation of the TMS7 during run.  1. Measure the voltage drop across each phase of the TMS7 (L1-T1, L2-T2, L3-T3). The voltage drop will be less than approximately 2 VAC when the TMS7 is operating correctly.
Control input test	This test verifies circuits connected to the TMS7 remote control inputs. (Start, Stop, Reset & FLC Select)  1. Measure the voltage across each input. With the remote circuit closed there should be 0VDC measured. If 24VDC is measured the switch/control is incorrectly connected or faulty.
Start performance test.	This test verifies correct operation of the TMS7 during start.  1. Determine the expected start current by multiplying the settings made in Function 1. <i>Motor Full Load Current</i> and Function 2. <i>Current Limit</i> .  2. Start the motor and measure the actual start current.  3. If the expected start current and the actual start current are the same, the TMS7 is performing correctly.
Power circuit test.	This test verifies the TMS7 power circuit including the SCR, firing loom and control module.  1. Remove the incoming supply from the TMS7 (L1, L2, L3 and control supply).

**Appendix**

**10.1 Typical Start Current Requirements**

	300%	350%	400%	450%
Agitator			•	
Atomiser			•	
Bottle Washer	•			
Centrifuge				•
Chipper				•
Compressor - Recip (loaded)				•
Compressor - Recip (unloaded)			•	
Compressor - Screw (loaded)			•	
Compressor - Screw (unloaded)		•		
Conveyor - Belt				•
Conveyor - Roller		•		
Conveyor - Screw			•	
Crusher - Cone		•		
Crusher - Jaw				•
Crusher - Rotary		•		
Crusher - Vertical Impact		•		
Debarker		•		
Dryer				•
Dust Collector		•		
Edger		•		
Fan - Axial (Damped)		•		
Fan - Axial (Un-damped)				•
Fan - Centrifugal (Damped)		•		
Fan - Centrifugal (Un-damped)				•
Fan - High Pressure				•
Grinder		•		
Hydraulic Power Pack		•		
Mill				•
Mill - Ball				•
Mill - Hammer				•
Mill - Roller				•
Mixer				•
Palletiser				•
Planer		•		
Press		•		
Pump - Bore	•			
Pump - Centrifugal		•		
Pump - Positive Displacement			•	
Pump - Slurry				•
Re-pulper				•
Rotary Table			•	
Sander			•	
Saw - Bandsaw				•
Saw - Circular		•		
Separator				•
Shredder				•
Slicer	•			
Tumbler			•	

The above table is intended as a guide only. Individual machine and motor characteristics will determine the actual start current requirements.

**10.2 AC53a Utilisation Codes**

AC53a Utilisation Category Format

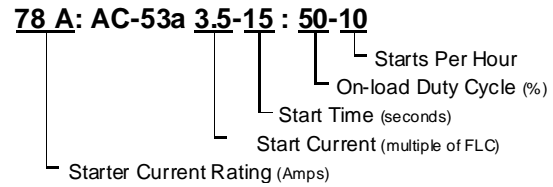

**Starter Current Rating:** The Full Load Current rating of soft starter given the parameters detailed in the remaining sections of the utilisation code.

**Start Current:** The maximum available start current given the parameters detailed in the remaining sections of the utilisation code.

**Start Time:** The maximum available start time given the parameters detailed in the remaining sections of the utilisation code.

**On-load Duty Cycle:** The maximum permissible percentage of each operating cycle that the soft starter can operate given the parameters detailed in the remaining sections of the utilisation code.

**Starts Per Hour:** The maximum available number of starts per hour given the parameters detailed in the remaining sections of the utilisation code.

**10.3 AC53b Utilisation Codes**

AC53b Utilisation Category Format

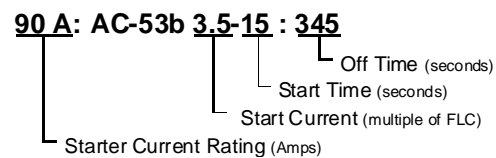

**Starter Current Rating:** The Full Load Current rating of soft starter given the parameters detailed in the remaining sections of the utilisation code.

**Start Current:** The maximum available start current given the parameters detailed in the remaining sections of the utilisation code.

**Start Time:** The maximum available start time given the parameters detailed in the remaining sections of the utilisation code.

**Off Time:** The minimum allowable time between end of one start and the beginning of the next start given the parameters detailed in the remaining sections of the utilisation code.



## Free Manuals Download Website

<http://myh66.com>

<http://usermanuals.us>

<http://www.somanuals.com>

<http://www.4manuals.cc>

<http://www.manual-lib.com>

<http://www.404manual.com>

<http://www.luxmanual.com>

<http://aubethermostatmanual.com>

Golf course search by state

<http://golfingnear.com>

Email search by domain

<http://emailbydomain.com>

Auto manuals search

<http://auto.somanuals.com>

TV manuals search

<http://tv.somanuals.com>