



# Packaged Cooling with Electric Heat Rooftop Units

---

**Precedent™**  
**3 - 10Tons — 60 Hz**



---

**August 2004**

**RT-PRC005-EN**



## Introduction

---

# Packaged Rooftop Air Conditioners

Through the years, Trane has designed and developed the most complete line of Packaged Rooftop products available in the market today. Trane was the first to introduce the Micro—microelectronic unit controls—and has continued to improve and revolutionize this design concept.

Electromechanical controls are available for simpler applications, and for the more sophisticated, ReliaTel™ microprocessor controls.

The ReliaTel control platform offers the same great features and functionality as the original Micro, with additional benefits for greater application flexibility.

With its sleek compact cabinet, rounded corners and beveled top Precedent continues to provide the highest standards in quality and reliability, comfort, ease of service, and the performance of Trane light commercial products.

Trane customers demand products that provide exceptional reliability, meet stringent performance requirements, and are competitively priced. Trane delivers with Precedent.

Precedent features cutting edge technologies: reliable compressors, Trane engineered ReliaTel controls, computer-aided run testing, and Integrated Comfort™ Systems. So, whether you're the contractor, the engineer, or the owner you can be certain Precedent Products are built to meet your needs.

It's Hard To Stop A Trane.®



# Contents

---

<b>Introduction</b>	2
<b>Features and Benefits</b>	4
<b>Application Considerations</b>	11
<b>Selection Procedure</b>	12
Model Number Description	14
<b>General Data</b>	15
<b>Performance Data</b>	19
Cooling Performance	19
Fan Performance	37
Heating Performance	59
<b>Controls</b>	62
<b>Electric Power</b>	64
<b>Dimension and Weights</b>	78
<b>Mechanical Specifications</b>	87



# Features and Benefits

---

## Factory Installed Options

- Black Epoxy Pre-Coated Coils
- Dehumidification Option
- High Pressure Cutout
- Hinged Access Doors
- Novar Return Air Sensor
- Novar Unit Controls
- Phase Monitor
- Powered or Unpowered Convenience Outlet
- Supply and/or Return Air Smoke Detector
- Thermal Expansion Valve
- Through the Base Electrical Access
- Through the Base Electrical With Circuit Breaker
- Through the Base Electrical With Disconnect Switch
- Two-Inch Pleated Filters

## Factory or Field Installed Options

- Clogged Filter/Fan Failure Switch
- Differential Pressure Switches
- Discharge Air Sensing Kit
- Economizer
- Electric Heaters
- Froststat
- LonTalk® Communications Interface
- Oversized Motors
- Reference or Comparative Enthalpy
- Tool-less Hail Guards
- Trane Communications Interface (TCI)

## Field Installed Options

- CO<sub>2</sub> Sensing
- Digital Display Zone Sensor
- Dual Thermistor Remote Zone Sensor
- High Static Drive
- Humidity Sensor
- Manual Outside Air Damper
- Motorized Outside Air Dampers
- Powered Exhaust
- Remote Potentiometer
- Roof Curb
- Thermostat
- Ventilation Override Accessory
- Zone Sensor

# Features and Benefits

## Easy to Install, Service and Maintain

Because today's owners are very cost-conscious when it comes to service and maintenance, the Trane Precedent was designed with direct input from service contractors. This valuable information helped to design a product that would get the serviceman off the job quicker and save the owner money. Precedent does this by offering:

## Quality and Reliability

### ReliaTel™ Controls (LCI-R)

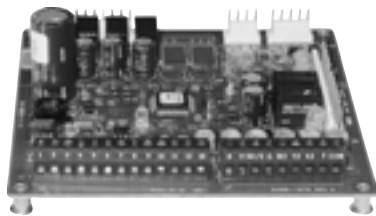

ReliaTel controls provide unit control for heating, cooling and ventilating utilizing input from sensors that measure outdoor and indoor temperature.

Quality and Reliability are enhanced through ReliaTel control and logic:

- prevents the unit from short cycling, considerably improving compressor life.
- ensures that the compressor will run for a specific amount of time which allows oil to return for better lubrication, enhancing the reliability of the compressor.

Precedent with ReliaTel reduces the number of components required to operate the unit, thereby reducing possibilities for component failure.

### ReliaTel Makes Installing and Servicing Easy

ReliaTel eliminates the need for field installed anti-shortcycle timer and time delay relays. ReliaTel controls provide these functions as an integral part of the unit. The contractor no longer has to purchase these controls as options and pay to install them.

The wiring of the low voltage connections to the unit and the zone sensors is as easy as 1-1, 2-2, and 3-3. This simplified system makes wiring easier for the installer.

### ReliaTel Makes Testing Easy

ReliaTel requires no special tools to run the Precedent unit through its paces. Simply place a jumper between Test 1 and Test 2 terminals on the Low Voltage Terminal Board and the unit will walk through its operational steps automatically.

- The unit automatically returns control to the zone sensor after stepping through the test mode a single time, even if the jumper is left on the unit.

As long as the unit has power and the "system on" LED is lit, ReliaTel is operational. The light indicates that the controls are functioning properly.

ReliaTel features expanded diagnostic capabilities when utilized with Trane Integrated Comfort™ Systems.

Some zone sensor options have central control panel lights which indicate the mode the unit is in and possible diagnostic information (dirty filters for example).

### Other ReliaTel Benefits

The ReliaTel built-in anti-shortcycle timer, time delay relay and minimum "on" time control functions are factory tested to assure proper operation.

ReliaTel softens electrical "spikes" by staging on fans, compressors and heaters.

Intelligent Fallback is a benefit to the building occupant. If a component goes astray, the unit will continue to operate at predetermined temperature setpoint.

Intelligent Anticipation is a standard ReliaTel feature. It functions continuously as ReliaTel and zone sensor(s) work together in harmony to provide much tighter comfort control than conventional electro-mechanical thermostats.

The same ReliaTel Board fits all Precedent Packaged Gas/Electrics, Cooling with Electric Heat, and Heat Pump models. This provides standardization of parts for contractors. Less money is tied up in inventory with ReliaTel.

### Electromechanical Controls

For the simpler job that does not require a building automation system, or expanded diagnostics capabilities, Precedent offers electromechanical controls. This 24-volt control includes the control transformer and contactor pressure lugs for power wiring.

ReliaTel™

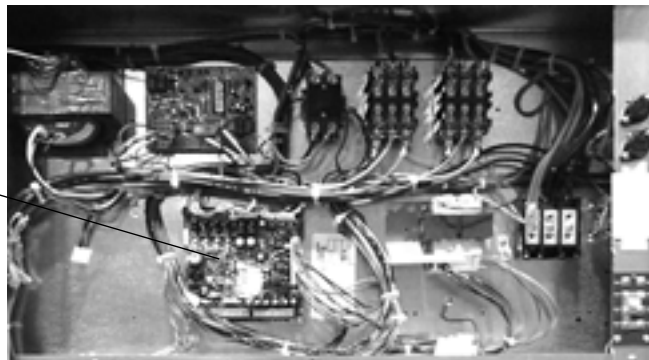

# Features and Benefits

## Outstanding Standard and Optional Components

### Black Epoxy Pre-Coated Coils

Provides corrosion protection to condenser coils for seacoast application.

### Cabinet Integrity

For added water integrity, Precedent has a raised 1 $\frac{1}{8}$ " lip around the supply and return of the downflow units to prevent water from blowing into the ductwork.

### Clogged Filter/Fan Failure Switch

A dedicated differential pressure switch is available to achieve active fan failure indication and/or clogged filter indication.

These sensors allow a zone sensor service light or Integrated Comfort System to indicate a dirty filter or a fan that's not working. The field installation charges for these valuable feedback devices often eliminate them from consideration. Factory installation can make such features a good investment.

### CO<sub>2</sub> Sensing

The CO<sub>2</sub> sensor has the ability to monitor space occupancy levels within the building by measuring the parts per million of CO<sub>2</sub> (Carbon Dioxide) in the air. As the CO<sub>2</sub> levels increase, the outside air damper modulates to meet the CO<sub>2</sub> space ventilation requirements. The CO<sub>2</sub> sensor kit is available as a field installed accessory.

### Colored And Numbered Wiring

Save time and money tracing wires and diagnosing the unit.

### Compressors

Precedent contains the best compressor technology available to achieve the highest possible performance. Our compressor line includes Trane built ClimaTuff® reciprocating and scrolls.



### Condenser Coil

Precedent boasts a patent-pending 1+1+1 condenser coil, permanently gapped for easy cleaning.

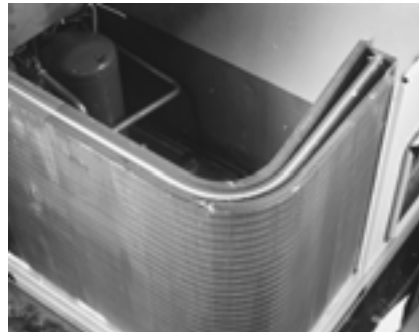

### Dehumidification (Hot Gas Reheat) Option

This option allows for increased outdoor air ventilation. It reduces humidity levels while increasing comfort level in the air space. Cooling can operate without a demand for dehumidification. The hot gas reheat coil is designed to deliver maximum reheat temperatures and pivot to allow for easy access cleaning.

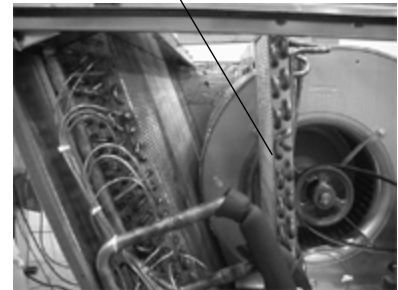

### Digital Display Zone Sensor

The Digital LCD (Liquid Crystal Display) zone sensor has the look and functionality of standard zone sensors. This sensor should be utilized with ReliaTel™ controls.

### Discharge Air Sensing Kit

Provides true discharge air sensing in heating models. The kit is functional only with the ReliaTel Options Module.

### Downflow And Horizontal Economizers

The economizers come with three control options — dry bulb is standard, enthalpy and differential enthalpy are optional.

### Dual Thermistor Remote Zone Sensor

This sensor will reduce the total number of remote sensors to obtain space temperature averaging. This sensor should be utilized with ReliaTel controls.

# Features and Benefits

## Foil-Faced Insulation

All panels in the evaporator section of the unit have cleanable foil-faced insulation. All edges are either captured or sealed to ensure no fibers get into the airstream.

## Factory Built Roof Curbs

Available for downflow units. Only two roof curbs for the entire Precedent line simplifies curb selection.

## Flexibility

Units are built to order in our standard "shortest in the industry" ship cycle time.

## Fresh Air

0 - 25% manual or 0 - 50% motorized outside air hoods are available.

## High Pressure Cutout

This factory-installed option is offered for units that do not have High Pressure Cutout as standard. All 3-phase units with scroll compressors include High Pressure cutout as standard.

## High Static Drive Accessory

Available on many models, this high static drive accessory extends the capability of the standard motor. Avoid expensive motors and operating costs by installing this optimized sheave accessory.

## Hinged Access Doors

These doors permit easy access to the filter, fan/heat, and compressor/control sections. They reduce the potential roof damage from screws or sharp access door corners.



## LonTalk® Communications Interface

The LonTalk communications interface allows the unit to communicate as a Tracer™ LCI-V device or directly with generic LonTalk Network Building Automation System Controls.

## Phase Monitor

Phase monitor shall provide 100% protection for motors and compressors against problems caused by phase loss, phase imbalance, and phase reversal. Phase monitor is equipped with an LED that provides an ON or FAULT indicator.

## Power Exhaust Option

This option is available on downflow units and provides exhaust of the return air, when using a downflow economizer, to maintain proper building pressurization. Great for relieving most building overpressurization problems.

## Quick-Access Panels

Remove two screws for access to the standardized internal components and wiring.

## Quick-Adjust Idler Arm

With the Quick-Adjust Idler Arm, the belt and sheaves can be quickly adjusted without moving the mounted fan motor. The result is a major savings in time and money.



## Reference or Comparative Enthalpy

Measures and communicates humidity while maximizing comfort control.

## Sloped Drain Pans

Every Precedent unit has a non-corrosive, removable, double-sloped drain pan that's easy to clean and reversible to allow installation of drain trap on either side of the unit.



## Standardized Components

Components are placed in the same location on all Precedent units. Familiarize yourself with one Precedent and you are familiar with every Precedent.

Due to standardized components throughout the Precedent line, contractors/owners can stock fewer parts.

## Supply and/or Return Air Smoke Detector



With this option installed, if smoke is detected, all unit operation will be shut down. Reset will be manual at the unit. Return Air Smoke Detectors require minimum allowable airflow when used with certain models.

## Thermal Expansion Valve

Available for a wider range of applications.

## Tool-less Hail Guards

Tool-less, hail protection quality coil guards shall be either factory or field-installed for condenser coil protection. This option protects the condenser coil from vandalism and/or hail damage.



## Trane Communication Interface (TCI)

Available factory or field installed. This module when applied with the ReliaTel™ easily interfaces with Trane's Integrated Comfort™ System.

# Features and Benefits

## Unit Cabinet

The compact cabinet with rounded corners takes up less room and is less costly to ship. The beveled and ribbed top is not only aesthetically pleasing, it is designed to prevent water from pooling.



## VariTrac

When Trane's changeover VAV System for light commercial applications is coupled with Precedent, it provides the latest in technological advances for comfort management systems and can allow thermostat control in every zone served by VariTrac.

## Ventilation Override Accessory

With the Ventilation Override Accessory installed, the unit can be set to transition to up to 3 different pre-programmed sequences for Smoke Purge, Pressurization, and Exhaust. The transition occurs when a binary input on the RTOM is closed (shorted). This would typically be a hard wired relay output from a smoke detector or fire control panel. The ventilation override kit is available as a field installed accessory.

## Zone Sensors

Available in programmable, automatic and manual styles.

Precedent offers ultimate flexibility. Units are built to order in our standard "shortest in the industry" ship cycle time.

## Rigorous Testing

All of Precedent's designs were rigorously rain tested at the factory to ensure water integrity.

Actual shipping tests were performed to determine packaging requirements. Units were test shipped around the country to determine the best packaging. Factory shake and drop tests were used as part of the package design process to help assure that the unit arrives at the job site in top condition.

Rigging tests include lifting a unit into the air and letting it drop one foot, assuring that the lifting lugs and rails hold up under stress.

We perform a 100% coil leak test at the factory. The evaporator and condenser coils are leak tested at 200 psig and pressure tested to 450 psig.

All parts are inspected at the point of final assembly. Sub-standard parts are identified and rejected immediately.

Every unit receives a 100% unit run test before leaving the production line to make sure it lives up to rigorous Trane requirements.

VariTrac™

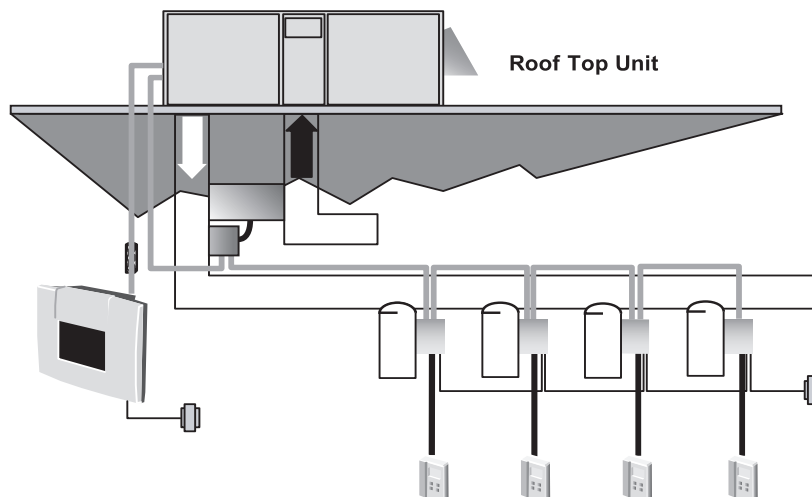



# Features and Benefits

## Easy to Install

### Convertible Units

- The units ship in a downflow configuration. They can be easily converted to horizontal by simply moving two panels.
- Units come complete with horizontal duct flanges so the contractor doesn't have to field fabricate them. These duct flanges are a time and cost saver.

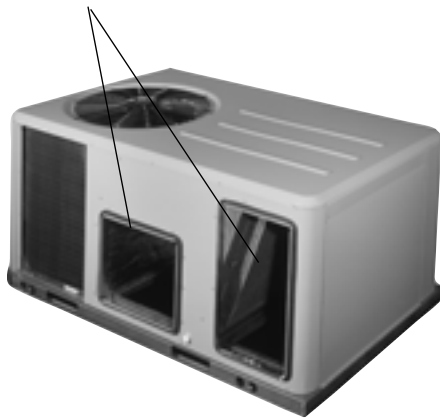

**Easy Access Low Voltage Terminal Board**  
 Precedent's Low Voltage Terminal Board is external to the electrical control cabinet. It is extremely easy to locate and attach the thermostat wire and test operation of all unit functions. This is another cost and time saving installation feature.

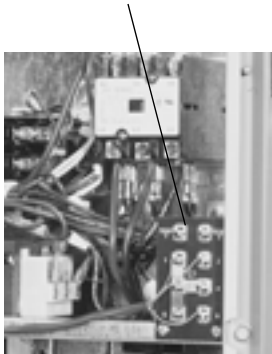

### Low Voltage Connections

The wiring of the low voltage connections to the unit and the zone sensors is as simple as 1-1, 2-2, and 3-3. This simplified system makes it easy for the installer to wire.

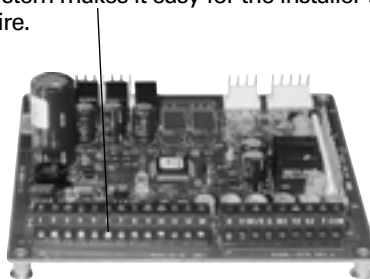

### Electric Heaters

Electric heat modules are available within the basic unit. If ordering the Through the Base Electrical option with an Electrical Heater, the heater must be factory installed.

### Powered or Unpowered Convenience Outlet

This option is a GFCI, 120v/15amp, 2 plug, convenience outlet, either powered or unpowered. This option can only be ordered when the Through the Base Electrical with either the Disconnect Switch, or Circuit Breaker, option is ordered. This option is available on all downflow models.



### Single Point Power

A single electrical connection powers the unit.

### Single Side Service

Single side service is standard on all units.

### Through the Base Condensate

Every unit includes provisions for through the base condensate drain connections. This allows the drain to be connected through the roof curb instead of a roof penetration.

### Through the Base Electrical Utility Access

Factory provided through the base openings simplify wiring and piping. Because these utility openings frequently minimize the number of roof penetrations, the integrity of roofing materials is enhanced.

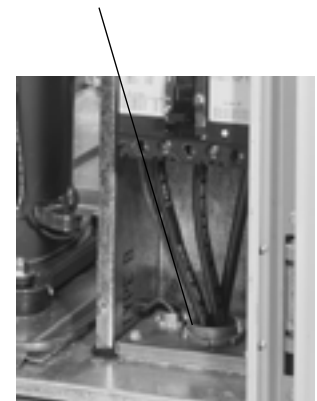

### Through the Base Electrical with Circuit Breaker

This option is a factory installed thermal magnetic, molded case, HACR Circuit Breaker with provisions for through the base electrical connections. This option is available on all downflow models.

# Features and Benefits

## Through the Base Electrical with Disconnect Switch

Factory installed 3-pole, molded case, disconnect switch with provisions for through the base electrical connections are available. This option is available on all downflow models.

## Through the Base Utilities Access

An electrical service entrance shall be provided allowing electrical access for both control and main power connections inside the curb and through the base of the unit. Option will allow for field installation of liquid-tight conduit and an external field installed disconnect switch.

## Unit Mounted Disconnect or Circuit Breaker

Codes require a method of assured unit shutdown for servicing. Field-installed disconnects sometimes interfere with service access. Factory installation of unit disconnects reduces costs, assures proper mounting and provides the opportunity to upgrade to unit circuit breaker protection.

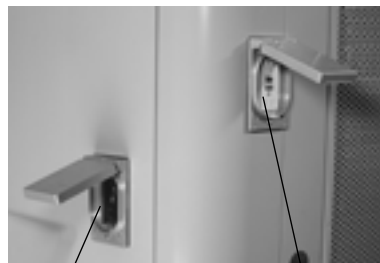

*Unit Mounted Disconnect  
or Circuit Breaker*

*Convenience Outlet*

## Factory Installed Options

A wide variety of Factory Installed Options (FIOPs) are available.

## Added Efficiency

### Airflow

Airflow is outstanding. The Precedent can replace an older machine with old ductwork and, in many cases, improve the comfort through better air distribution.

Belt or direct drive – standard or oversized supply fan motors meet a wide airflow range.

### Cooling

Standard or High Efficiency Cooling available.

### Economizer

Equipped with either dry bulb, reference or comparative enthalpy sensing, this feature provides free cooling as the outdoor temperature and/or humidity decreases. Economizers, correctly installed, offer a valuable energy savings. Factory-installed economizers save time and ensure proper installation.

### High Efficiency Motors

This option is available with efficiency ratings from 86.5 up to 91.0. It is not available for all models.

### Low Ambient Cooling

All Precedent microprocessor units have cooling capabilities down to 0°F as standard. Electromechanical models have cooling capabilities to 40°F as built, or to 0°F by adding the optional low ambient control (froststat).

### Oversized Motors

Factory or field installed oversized motors available for high static applications.

### One of our Finest Assets:

Trane Sales Representatives are a Support Group that can assist you with:

- Product
- Application
- Service
- Training
- Special Applications
- Specifications
- Computer Programs and much more

Precedent has the features and benefits that make it first class in the light commercial rooftop market.

# Application Considerations

---

Application of this product should be within the cataloged airflow and cooling considerations.

## **Low Ambient Cooling**

The Precedent™ line features, with ReliaTel™ microprocessor controls, low ambient cooling down to 0°F. With electromechanical controls, Precedent features low ambient cooling to 40°F. The following options need to be included/considered when low ambient applications are required: continuous fan operation, crankcase heaters, thermal expansion valves, froststat. Contact your local Trane Representative for more assistance with low ambient cooling applications.

## **Barometric Relief**

This product line offers an optional barometric relief damper. for use in conjunction with economizer option. This accessory consists of gravity dampers which open with increased pressure. As the building air pressure increases, the pressure in the unit return air section also increases, opening the dampers and relieving the conditioned space.

NOTE: THE EFFECTIVENESS OF BAROMETRIC RELIEF DAMPER DURING ECONOMIZING OPERATION IS SYSTEM RELATED.

PRESSURE DROP OF THE RETURN AIR SYSTEM SHOULD BE CONSIDERED TO CONTROL BUILDING PRESSURIZATION.

## **Condensate Trap**

The evaporator is a draw-thru configuration. A trap must be field provided prior to start-up on the cooling cycle.

## **Clearance Requirements**

The recommended clearances identified with unit dimensions should be maintained to assure adequate service maximum capacity and peak operating efficiency. Actual clearances which appear inadequate should be reviewed with the local Trane sales personnel.

## **Unit Pitch**

These units have reversible sloped condensate drain pans. Units must be installed level, any unit slope must be toward the side of unit where condensate drain is connected.



# Selection Procedures

## Cooling Capacity

### Step 1

Calculate the building's total and sensible cooling loads at design conditions. Use the Trane calculation methods or any other standard accepted method.

Factors used in unit selection:

- A** Total Cooling Load: 59 MBh
- B** Sensible Cooling Load: 40 MBh
- C** Airflow: 2000 cfm
- D** Electrical Characteristics: 460/60/3
- E** Summer Design Conditions: Entering Evaporator Coil: 80 DB, 67 WB Outdoor Ambient: 95
- F** External Static Pressure: 0.36 in. wg
- G** Downflow Configuration
- H** High Efficiency
- I** Economizer

### Step 2

As a starting point, a rough determination must be made of the size of the unit. The final selection will be made after examining the performance at the given conditions. Divide the total cooling load by nominal BTUH per ton (12 MBh per ton); then round up to the nearest unit size.

$$59 \text{ MBh} / 12 \text{ MBh} = \text{approx. } 5 \text{ tons}$$

### Step 3

Table PD-15 shows that a THC060A4 has a gross cooling capacity of 62.4 MBh and 48.4 MBh sensible capacity at 2000 cfm and 95 DB outdoor ambient with 80 DB, 67 WB air entering the evaporator.

### To Find Capacity at Intermediate Conditions Not in the Table

When the design conditions are between two numbers that are in the capacity table, interpolation is required to approximate the capacity. Note: Extrapolation outside of the table conditions is not recommended.

### Step 4

In order to select the correct unit which meets the building's requirements, the fan motor heat must be deducted from the gross cooling capacity. The amount of heat that the fan motor generates is dependent on the effort by the motor - cfm and static pressure. To determine the total unit static pressure:

External Static (duct system)	0.36 wg
Standard Filter 1 in. from Table PD-61	0.15 wg
Economizer (100% Outside Air) from Table PD-73	0.18 wg
Electric Heater Size 6 kW from Table PD-61	0.056 wg
(reference "Heating Capacity" section on this page for determination of heater size)	
Total Static Pressure	0.75 wg

Note: The Evaporator Fan Performance Table PD-46 has deducted the pressure drop for a 1 in. filter already in the unit (see note below Table PD-24). Therefore, the actual total static pressure is 0.75 - 0.15 (from Table PD - 61) = 0.60 wg.

With 2000 cfm and 0.60 wg. Table PD-46 shows .90 bhp for this unit. Note below the table gives a formula to calculate Fan Motor Heat,  $2.829 \times \text{bhp} + .4024 = \text{MBH}$ .  $2.829 \times .83 + .4024 = 2.75 \text{ MBH}$ .

Now subtract the fan motor heat from the gross cooling capacity of the unit:  
 Net Total Cooling Capacity = 62.4 MBH - 2.95 = 59.45 MBH.

Net Sensible Cooling Capacity = 48.4 MBH - 2.95 = 45.45 MBH.

### Step 5

If the performance will not meet the required load of the building's total or sensible cooling load, try a selection at the next higher size unit.

## Heating Capacity

### Step 1

Calculate the building heating load using the Trane calculation form or other standard accepted method.

### Step 2

Size the system heating capacity to match the calculated building heating load. The following are building heating requirements:

- A** Total heating load of 15 MBH
- B** 2000 cfm
- C** 460 volt/3 phase Power Supply

The electric heat accessory capacities are listed in Table PD-62. From the table, a 6 kW heater will deliver 20.48 MBH at 480 volts. In order to determine capacity at 460 volts, the heater voltage correction factor from Table PD-63 must be used. Therefore,  $20.48 \text{ MBH} \times .9118$  (voltage correction factor) = 18.80 MBH.

### Air Delivery Selection

External static pressure drop through the air distribution system has been calculated to be 0.60 inches of water. Enter Table PD-46 for a THC060A4 at 2000 cfm and 0.60 static pressure. The standard direct drive motor will give the desired airflow at a rated bhp of 0.90 and 998 rpm.

# Selection Procedure

## Dehumidification Selection

Typical 10 ton THC120A  
 2000 cfm Total Supply airflow  
 800 cfm Outside Air (40%)  
 1200 cfm Return Air  
 0.41" External Static Pressure

OA Conditions

*Part load day and raining*  
 68°F db  
 67°F wb

RA' conditions

75°F db  
 63°F wb

### Step 1: Determine the mixed/entering air condition (MA')

MA' = (% outside air\*outside air dry-bulb temperature) + (% return air\*return air dry-bulb temperature)

$$MA' = (0.40*68°F) + (0.60*75°F)$$

$$MA' = 72.20°F \text{ db}$$

**Note: Repeat for wet-bulb temperature (wb).**

Plot on psychrometric chart.

MA'

72.2°F db  
 65°F wb

### Step 2: Determine leaving unit temperature

Leaving Unit Temperature = SA'

Utilize the TOPSS™ program to determine the leaving unit temperature.

45°F db

44°F wb

43°F dp

### Step 3: Determine reheat temperature rise

Go to PD-66 for reheat temperature rise:  
 26.7°F db

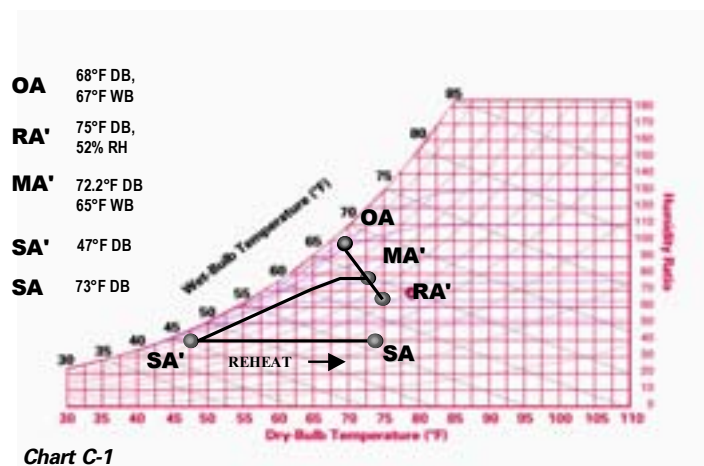

Chart C-1

*Note: Reheat temperature rise is based on supply airflow and leaving evaporator coil temperature.*

### Step 4: Determine leaving unit temperature

Reheat temperature (obtained in step 3)

$$+ SA' = 26.7°F \text{ db} + 47°F = 73.7°F \text{ db}$$

$$SA = 73.7°F$$

Consider Chart C-1. If the space relative humidity is equal to or above the space relative humidity setpoint, the Dehumidification option will:

- Energize compressor or both compressors (2 stage compressor units).
- Hot gas reheat valve is energized and hot gas is diverted to the reheat coil.
- Dehumidification/reheat is terminated when space humidity is reduced to 5% below relative humidity setpoint.

At MA', air enters the RTU. The RTU filters, cools, and dehumidifies the air as it moves through the evaporator coil. Air leaves the evaporator coil saturated at the preset dew point condition (SA') and is reheated by the hot gas reheat coil to deliver 73.7°F (SA) supply air to the space.

### Step 5: Determine static pressure drop add for reheat

Table PD-61 shows a static pressure drop of 0.09" wc.  $0.41" + 0.09" = 0.5" \text{ wc}$

Table PD-57 indicates that a standard motor and field installed low static drive kit is needed for this airflow and static pressure range.



# Model Number Description

**T S C 036 A 3 R B A \*\* C 0 0 0 A 1 0 0 0 1 A 1**  
**1 2 3 4,5,6 7 8 9 10 11 12,13 14 15 16 17 18 19 20 21 22 23 24 25**

### DIGIT 1 - Unit Function

T = DX Cooling

### DIGIT 2 - Efficiency

S = Standard Efficiency  
 H = High Efficiency

### DIGIT 3 - Airflow

C = Convertible

### DIGITS 4,5,6 - Nominal Gross Cooling Capacity (MBh)

036 = 3 Ton  
 048 = 4 Ton  
 060 = 5 Ton  
 072 = 6 Ton  
 090 = 7½ Ton, Single Compressor  
 092 = 7½ Ton, Dual Compressor  
 102 = 8½ Ton  
 120 = 10 Ton

### DIGIT 7 - Major Design Sequence

A = First

### DIGIT 8 - Unit Voltage

1 = 208-230/60/1  
 3 = 208-230/60/3  
 4 = 460/60/3  
 W = 575/60/3  
 K = 380/60/3

### DIGIT 9 - Unit Controls

E = Electromechanical  
 R = ReliaTel™ Microprocessor

### DIGIT 10 - Heating Capacity

0 = No Electric Heat  
 A = 5 kW (1 phase)  
 B = 6 kW (3 phase)  
 C = 9 kW (3 phase)  
 D = 10 kW (1 phase)  
 E = 12 kW (3 phase)  
 F = 14 kW (1 phase)  
 G = 18 kW (1 and 3 phase)  
 J = 23 kW (3 phase)  
 K = 27 kW (3 phase)  
 N = 36 kW (3 phase)  
 P = 54 kW (3 phase)

### DIGIT 11 - Minor Design Sequence

A = First Sequence

### DIGITS 12, 13 - Service Sequence

\*\* = Factory Assigned

### DIGIT 14 - Fresh Air Selection

0 = No Fresh Air  
 A = Manual Outside Air Damper 0-50%  
 B = Motorized Outside Air Damper 0-50%  
 C = Economizer, Dry Bulb 0-100% without Barometric Relief  
 D = Economizer, Dry Bulb 0-100% with Barometric Relief  
 E = Economizer, Reference Enthalpy 0-100% without Barometric Relief  
 F = Economizer, Reference Enthalpy 0-100% with Barometric Relief  
 G = Economizer, Comparative Enthalpy 0-100% without Barometric Relief  
 H = Economizer, Comparative Enthalpy 0-100% with Barometric Relief

### DIGIT 15 - Supply Fan/Drive Type/Motor

0 = Standard Drive  
 1 = Oversized Motor  
 2 = Optional Belt Drive Motor

### DIGIT 16 - Hinged Service Access/Filters

0 = Standard Panels/Standard Filters  
 A = Hinged Access Panels/Standard Filters  
 B = Standard Panels/2" Pleated Filters  
 C = Hinged Access Panels/2" Pleated Filters

### DIGIT 17 - Condenser Coil Protection

0 = Standard Coil  
 1 = Standard Coil with Hail Guard  
 2 = Epoxy Coated Condenser Coil  
 3 = Epoxy Coated Condenser Coil with Hail Guard

### DIGIT 18 - Through the Base Provisions

0 = No Through the Base Provisions  
 A = Through the Base Electric

### DIGIT 19 - Disconnect/Circuit Breaker/Phase Monitor (3 phase only)

0 = No Disconnect/No Circuit Breaker/No Phase Monitor  
 1 = Unit Mounted Non-Fused Disconnect  
 2 = Unit Mounted Circuit Breaker  
 3 = Phase Monitor  
 4 = Phase Monitor & Non-Fused Disconnect Switch  
 5 = Phase Monitor & Circuit Breaker

### DIGIT 20 - Convenience Outlet

0 = No Convenience Outlet  
 A = Unpowered Convenience Outlet  
 B = Powered Convenience Outlet (3 phase only)

### DIGIT 21 - Communications Options

0 = No Communications Interface  
 1 = Trane Communications Interface  
 2 = LonTalk® Communications Interface  
 3 = Novar 2024 Controls  
 4 = Novar 3051 Controls

### DIGIT 22 - Refrigeration System Option

0 = Standard Refrigeration System  
 A = Thermal Expansion Valve (TXV)  
 B = Dehumidification (Hot Gas Reheat Coil)

### DIGIT 23 - Refrigeration Controls

0 = No Refrigeration Control  
 1 = High Pressure Control  
 2 = Froststat  
 3 = Crankcase Heater  
 4 = High Pressure Control and Froststat  
 5 = High Pressure Control and Crankcase Heater  
 6 = Froststat and Crankcase Heater  
 7 = High Pressure Control, Froststat and Crankcase Heater

### DIGIT 24 - Smoke Detector

0 = No Smoke Detector  
 A = Return Air Smoke Detector  
 B = Supply Air Smoke Detector  
 C = Supply and Return Air Smoke Detectors

### DIGIT 25 - Monitoring Controls

0 = No Monitoring Control  
 1 = Clogged Filter Switch  
 2 = Fan Failure Switch  
 3 = Discharge Air Sensing Tube  
 4 = Clogged Filter Switch and Fan Fail Switch  
 5 = Clogged Filter Switch and Discharge Air Sensing Tube  
 6 = Fan Fail Switch and Discharge Air Sensing Tube  
 7 = Clogged Filter and Fan Fail Switches and Discharge Air Sensing Tube  
 8 = Novar Return Air Sensor

### Example:

Model number TSC036A3RBA\*\*C000A10001A1 describes a unit with the following characteristics: DX Cooling, 3 ton nominal cooling capacity, 208-230/60/3 power supply, ReliaTel™ controls, 6 kW electric heater model, 0-100% dry bulb economizer without barometric relief, standard direct drive motor, standard access panels/filters, standard condenser coil with no coil protection, through the base electric, non-fused disconnect, no convenience outlet or communications interface, standard refrigeration coil, high pressure control, return air smoke detector, and clogged filter switch.



# General Data

# (3 - 5 Ton) Standard Efficiency

**Table GD - 1 - General Data**

	3Ton Convertible Units		4Ton Convertible Units		5Ton Convertible Units	
	TSC036A1, A3, A4, AW		TSC048A1	TSC048A3, A4, AW	TSC060A1	TSC060A3, A4, AW
<b>Cooling Performance<sup>1</sup></b>						
Gross Cooling Capacity	37,400	50,300	49,200	63,100	63,100	63,100
SEER <sup>2</sup>	10.7 <sup>5</sup>	10.1	10.0	9.9	10.2	10.2
Nominal CFM / ARI Rated CFM	1,200/1,200	1,600/1,600	1,600/1,600	2,000/2,000	2,000/2,000	2,000/2,000
ARI Net Cooling Capacity	36,000	48,000	47,000	60,000	60,000	60,000
System Power (kW)	3.79 <sup>8</sup>	5.28	5.40	6.86	6.78	6.78
<b>Compressor</b>						
No./Type	1/Recip.	1/Scroll	1/Scroll	1/Scroll	1/Scroll	1/Scroll
<b>Outdoor Sound Rating (dB)<sup>3</sup></b>						
	83	86	82	84	84	84
<b>Outdoor Coil - Type</b>						
Tube Size (in.) O.D.	Lanced	Lanced	Lanced	Lanced	Lanced	Lanced
Face Area (sq ft)	0.3125	0.3125	0.3125	0.3125	0.3125	0.3125
Rows/FPI	7/19	6.17	9.59	8.81	8.81	8.81
	2/17	2/17	1/17	2/17	2/17	2/17
<b>Indoor Coil - Type</b>						
Tube Size (in.)	Lanced	Lanced	Lanced	Lanced	Lanced	Lanced
Face Area (sq ft)	0.3125	0.3125	0.3125	0.3125	0.3125	0.3125
Rows/FPI	5.67	6.68	6.17	5.00	5.00	5.00
	2/16	3/16	3/16	3/16	3/16	3/16
Refrigerant Control	Short Orifice	Short Orifice	Short Orifice	Short Orifice	Short Orifice	Short Orifice
Drain Connection No./Size (in.)	1/4 NPT	1/4 NPT	1/4 NPT	1/4 NPT	1/4 NPT	1/4 NPT
<b>Outdoor Fan - Type</b>						
No. Used/Diameter (in.)	Propeller	Propeller	Propeller	Propeller	Propeller	Propeller
Drive Type/No. Speeds	1/22	1/22	1/22	1/22	1/22	1/22
CFM	Direct/1	Direct/1	Direct/1	Direct/1	Direct/1	Direct/1
No. Motors/HP	2550	2850	3610	3470	3470	3470
Motor RPM	1/.20	1/.33	1/.33	1/.33	1/.33	1/.40
	1115	1115	1115	1115	1115	1115
<b>Direct Drive Indoor Fan - Type</b>						
No. Used	FC Centrifugal	FC Centrifugal	FC Centrifugal	FC Centrifugal	FC Centrifugal	FC Centrifugal
Diameter x Width (in.)	1	1	1	1	1	1
Drive Type/No. Speeds	10 x 10	11 x 11	11 x 11	11 x 11	11 x 11	12x11/-
No. Motors	Direct/2	Direct/2	Direct/2	Direct/2	Direct/2	Direct/2
Motor HP (Standard/Oversized)	1	1	1	1	1	1
Motor RPM (Low/High Speed)	.33/.50	.60/.80	.60/.80	.90/1.00	.90/1.00	1.0/-
Oversized Motor RPM (Low/High Speed)	950/1060	930/1000	930/1000	985/1100	985/1100	935/1100
Motor Frame Size (Standard/Oversized)	1100/1145	1000/1100	1000/1100	1080/1135	1080/1135	-
<b>Belt Drive Indoor Fan - Type</b>						
No. Used	FC Centrifugal	-	FC Centrifugal	-	FC Centrifugal	-
Diameter x Width (in.)	1	-	1	-	1	-
Drive Type/No. Speeds	11 x 11	-	11 x 11	-	11 x 11	-
No. Motors	Belt/Variable Speed <sup>6</sup>	-	Belt/Variable Speed	-	Belt/Variable Speed	-
Motor HP	1	-	1	-	1	-
Motor RPM	1.00	-	1.00	-	1.00	-
Motor Frame Size	1750	-	1750	-	1750	-
	56	-	56	-	56	-
<b>Filters - Type Furnished<sup>7</sup></b>						
(No.) Size Recommended (in.)	Throwaway	Throwaway	Throwaway	Throwaway	Throwaway	Throwaway
	(2) 20 x 25 x 1	(2) 20 x 25 x 1	(2) 20 x 25 x 1	(2) 20 x 25 x 1	(2) 20 x 25 x 1	(2) 20 x 25 x 1
<b>Refrigerant Charge (Lbs of R-22)<sup>4</sup></b>						
	3.8	4.4	3.8	4.7	4.9	4.9

**Notes:**

- Cooling Performance is rated at 95 F ambient, 80 F entering dry bulb, 67 F entering wet bulb. Gross capacity does not include the effect of fan motor heat. ARI capacity is net and includes the effect of fan motor heat. Units are suitable for operation to ±20% of nominal cfm. Certified in accordance with the Unitary Air-Conditioner Equipment certification program, which is based on ARI Standard 210/240 except AK (380V/60 Hz).
- SEER is rated at ARI conditions and in accordance with DOE test procedures.
- Outdoor Sound Rating shown is tested in accordance with ARI Standard 270. For more information refer to Table PD-60.
- Refrigerant charge is an approximate value. For a more precise value, see unit nameplate and service instructions.
- TSC036A1 SEER is 10.5.
- Belt Drive Motor is not available for TSC036A1.
- Optional 2" Pleated Filters also available.
- TSC036A1 System Power (kW) is 3.91.



# General Data

# (6 - 10 Ton) Standard Efficiency

Table GD - 2- General Data

	6Ton	7½Ton		8½Ton	10Ton
	Convertible Units TSC072A3, A4, AW, AK	Convertible Units TSC090A3,A4,AW, AK	Convertible Units TSC092A3, A4, AW	Convertible Units TSC102A3, A4, AW, AK	Convertible Units TSC120A3, A4, AW, AK
<b>Cooling Performance<sup>1</sup></b>					
Gross Cooling Capacity	72,000	95,000	92,000	105,000	118,000
EER <sup>2</sup>	10.3	10.3	10.3	10.3	10.4 <sup>6</sup>
Nominal CFM / ARI Rated CFM	2,400/2,100	3,000/2,625	3,000/2,625	3,400/3,000	4,000/3,200
ARI Net Cooling Capacity	69,000	90,000	87,000	100,000 <sup>7</sup>	114,000 <sup>7</sup>
Integrated Part Load Value (IPLV) <sup>3</sup>	-	-	11.1 <sup>8</sup>	11.9 <sup>8</sup>	11.5 <sup>8</sup>
System Power (kW)	6.7	8.74	8.45	9.71 <sup>9</sup>	10.96 <sup>9</sup>
<b>Compressor</b>					
No./Type	1/Scroll	1/Scroll	2/Scrolls	2/Scrolls	2/Scrolls
<b>Outdoor Sound Rating (dB)<sup>4</sup></b>					
	88	90	87	86	86
<b>Outdoor Coil — Type</b>					
	Lanced	Lanced	Lanced	Lanced	Lanced
Tube Size (in.) O.D.	0.3125	0.3125	0.3125	0.3125	0.3125
Face Area (sq ft)	13.88	17.00	17.00	19.83	19.83
Rows/FPI	2/17	3/17	2/17	2/17	2/17
<b>Indoor Coil — Type</b>					
	Lanced	Lanced	Lanced	Lanced	Lanced
Tube Size (in.)	0.3125	0.3125	0.3125	0.3125	0.3125
Face Area (sq ft)	9.89	9.89	9.89	12.36	12.36
Rows/FPI	2/16	3/16	3/16	3/16	4/16
Refrigerant Control	Short Orifice	Short Orifice	Short Orifice	Short Orifice	Short Orifice
Drain Connection No./Size (in.)	1¼ NPT	1¼ NPT	1¼ NPT	1¼ NPT	1¼ NPT
<b>Outdoor Fan — Type</b>					
	Propeller	Propeller	Propeller	Propeller	Propeller
No. Used/Diameter (in.)	1/26	1/26	1/26	1/26	1/26
Drive Type/No. Speeds	Direct/1	Direct/1	Direct/1	Direct/1	Direct/1
CFM	6100	6200	6500	7100	7000
No. Motors/HP	1/0.70 <sup>11</sup>	1/0.70 <sup>11</sup>	1/0.70	1/0.75	1/0.75
Motor RPM	1115	1115	1115	1115	1115
<b>Belt Drive Indoor Fan — Type</b>					
	FC Centrifugal	FC Centrifugal	FC Centrifugal	FC Centrifugal	FC Centrifugal
No. Used	1	1	1	1	1
Diameter x Width (in.)	12 x 12	12 x 12	12 x 12	15 x 15	15 x 15
Drive Type/No. Speeds	Belt/Variable Speed	Belt/Variable Speed	Belt/Variable Speed	Belt/Variable Speed	Belt/Variable Speed
No. Motors	1	1	1	1	1
Motor HP (Standard/Oversized)	1.00/2.00 <sup>12</sup>	2.00/3.00	2.00/3.00	2.00/3.00	3.00/5.00
Motor RPM (Standard/Oversized)	1750	1750	1750	1750	1750/3450
Motor Frame Size	56	56	56	56	56
<b>Filters — Type Furnished<sup>10</sup></b>					
	Throwaway	Throwaway	Throwaway	Throwaway	Throwaway
(No.) Size Recommended (in.)	(4) 16 x 25 x 2	(4) 16 x 25 x 2	(4) 16 x 25 x 2	(4) 20 x 25 x 2	(4) 20 x 25 x 2
<b>Refrigerant Charge (Lbs of R-22)<sup>5</sup></b>					
	71	11.5	6.2 Circuit 1 3.4 Circuit 2	7.9 Circuit 1 4.0 Circuit 2	7.2 Circuit 1 5.3 Circuit 2

Notes:

- Cooling Performance is rated at 95 F ambient, 80 F entering dry bulb, 67 F entering wet bulb. Gross capacity does not include the effect of fan motor heat. ARI capacity is net and includes the effect of fan motor heat. Units are suitable for operation to ±20% of nominal cfm. Certified in accordance with the Unitary Air-Conditioner Equipment certification program, which is based on ARI Standard 210/240 except AK (380V/60 Hz).
- SEER is rated at ARI conditions and in accordance with DOE test procedures.
- Integrated Part Load Value is rated in accordance with ARI Standard 210/240 or 360. Units are rated at 80°F ambient, 80°F entering dry bulb, and 67°F entering wet bulb at ARI rated cfm.
- Outdoor Sound Rating shown is tested in accordance with ARI Standard 270. For more information refer to Table PD-60.
- Refrigerant charge is an approximate value. For a more precise value, see unit nameplate and service instructions.
- EER shown is for downflow airflow. EER for horizontal airflow is 10.3.
- ARI Net Cooling Capacity shown is for downflow airflow. Cooling Capacity for Horizontal airflow TSC102A is 99,000; TSC120A is 112,000.
- Integrated Part Load Value (IPLV) shown is for downflow airflow. IPLV for Horizontal airflow TSC092A is 10.8; TSC102A is 11.5; TSC120A is 11.0.
- System Power (kW) shown is for downflow airflow. System Power (kW) for Horizontal airflow TSC102A is 9.61; for TSC120A is 10.87.
- Optional 2" Pleated Filters also available.
- Outdoor motor is 0.75 hp for AK (380V/60 Hz units).
- Standard indoor motor is 2.00 hp for AK (380V/60 Hz) units.





# General Data

# (3 - 5 Ton) High Efficiency

Table GD – 3 – General Data

	3Ton Convertible Units THC036A1,A3,A4,AW	4Ton Convertible Units THC048A1,A3,A4,AW	5Ton Convertible Units THC060A1 THC060A3,A4,AW	
<b>Cooling Performance<sup>1</sup></b>				
Gross Cooling Capacity	38,000	49,800	62,100	62,400
SEER / EER <sup>2</sup>	12.5/—	12.0/—	11.8/—	12.0/—
Nominal CFM / ARI Rated CFM	1,200/1,200	1,600/1,600	2,000/2,000	2,000/2,000
ARI Net Cooling Capacity	36,600	47,500	59,000	59,500
System Power (kW)	3.33	4.48	5.73	5.56
<b>Compressor</b>				
No./Type	1/Climatuff Scroll	1/Climatuff Scroll	1/Climatuff Scroll	1/Climatuff Scroll
<b>Outdoor Sound Rating (dB)<sup>3</sup></b>				
	83	85	84	84
<b>Outdoor Coil — Type</b>				
	Lanced	Lanced	Lanced	Lanced
Tube Size (in.) O.D.	0.3125	0.3125	0.3125	0.3125
Face Area (sq ft)	7.19	9.59	10.96	10.96
Rows/FPI	2/17	3/17	3/17	3/17
<b>Indoor Coil — Type</b>				
	Lanced	Lanced	Lanced	Lanced
Tube Size (in.)	0.3125	0.3125	0.3125	0.3125
Face Area (sq ft)	6.68	6.68	7.71	7.71
Rows/FPI	3/16	4/16	4/16	4/16
Refrigerant Control	Short Orifice	Short Orifice	Short Orifice	Short Orifice <sup>9</sup>
Drain Connection No./Size (in.)	1/4" NPT	1/4" NPT	1/4" NPT	1/4" NPT
<b>Outdoor Fan — Type</b>				
	Propeller	Propeller	Propeller	Propeller
No. Used/Diameter (in.)	1/22	1/22	1/22	1/22
Drive Type/No. Speeds	Direct/1 <sup>10</sup>	Direct/1 <sup>10</sup>	Direct/1	Direct/1 <sup>10</sup>
CFM	2550	3050	3170	3370
No. Motors/HP	1/.20	1/.33	1/.33	1/.33
Motor RPM	1115	1115	1115	1115
<b>Direct Drive Indoor Fan — Type</b>				
	FC Centrifugal	FC Centrifugal	FC Centrifugal	FC Centrifugal
No. Used	1	1	1	1
Diameter x Width (in.)	10 x 10	11 x 11	11 x 11	11 x 11
Drive Type/No. Speeds	Direct/2	Direct/2	Direct/2	Direct/2
No. Motors	1	1	1	1
Motor HP (Standard/Oversized)	.33/.50	.60/.80	.90/1.00	.90/1.00
Standard Motor RPM (Low/High Speed)	950/1060	930/1000	985/1100	985/1100
Oversized Motor RPM (Low/High Speed)	1100/1145	1000/1100	1080/1135	1080/1135
Motor Frame Size (Standard/Oversized)	48/48	48/48	48/48	48/48
<b>Belt Drive Indoor Fan — Type</b>				
	FC Centrifugal	FC Centrifugal	—	FC Centrifugal
No. Used	1	1	—	1
Diameter x Width (in.)	11 x 11	11 x 11	—	11 x 11
Drive Type/No. Speeds	Belt/Variable Speed <sup>6</sup>	Belt/Variable Speed <sup>6</sup>	—	Belt/Variable Speed
No. Motors	1	1	—	1
Motor HP	1.00	1.00	—	1.00
Standard Motor RPM	1750	1750	—	1750
Motor Frame Size	56	56	—	56
<b>Filters — Type Furnished<sup>7</sup></b>				
(No.) Size Recommended (in.)	Throwaway (2) 20 x 25 x 1	Throwaway (2) 20 x 25 x 1	Throwaway (2) 20 x 30 x 1	Throwaway (2) 20 x 30 x 1 <sup>11</sup>
<b>Optional Hot Gas Reheat Coil-Type<sup>12</sup></b>				
	Lanced	Lanced	—	Lanced
Tube Size (in.) OD	0.375	0.375	—	0.375
Face Area (sq. ft)	2.22	2.22	—	2.22
Rows/FPI	1/16	1/16	—	2/16
<b>Refrigerant Charge (Lbs of R-22)<sup>4</sup></b>				
Standard	5.3 <sup>8</sup>	7.7 <sup>5</sup>	7.9	8.4
Optional Hot Gas Reheat Coil	5.3	8.5	—	10.7

Notes:

- Cooling Performance is rated at 95 F ambient, 80 F entering dry bulb, 67 F entering wet bulb. Gross capacity does not include the effect of fan motor heat. ARI capacity is net and includes the effect of fan motor heat. Units are suitable for operation to ±20% of nominal cfm. Units are certified in accordance with the Unitary Air-Conditioner Equipment certification program, which is based on ARI Standard 210/240.
- EER and SEER are rated at ARI conditions and in accordance with DOE test procedures.
- Outdoor Sound Rating shown is tested in accordance with ARI Standard 270. For more information refer to Table PD-60.
- Refrigerant charge is an approximate value. For a more precise value, see unit nameplate and service instructions.
- Refrigerant Charge shown is for 3 phase. 1 phase Refrigerant Charge is 8.1.
- Belt Drive Motor is not available for THC036A1, THC048A1.
- Optional 2" Pleated Filters also available.
- Refrigerant Charge shown is for 3 phase. 1 phase Refrigerant Charge is 4.5.
- TXV is supplied from the factory as standard with the Dehumidification (Hot Gas Reheat) option.
- With Dehumidification (Hot Gas Reheat) option: Direct/2 speed.
- 2" pleated filters is a factory installed option. 2" pleated filters is standard with the Dehumidification (Hot Gas Reheat) option.
- Available on three-phase only.



# General Data

# (6 - 10 Ton) High Efficiency

Table GD – 4 – General Data

	6Ton	7½Ton	8½Ton	10Ton
	Convertible Units THC072A3, A4, AW	Convertible Units THC092A3, A4, AW	Convertible Units THC102A3, A4, AW	Convertible Units THC120A3, A4, AW
<b>Cooling Performance<sup>1</sup></b>				
Gross Cooling Capacity	73,000	94,000	103,000	117,000
EER <sup>2</sup>	11.5 <sup>6</sup>	11.5 <sup>6</sup>	11.5 <sup>6</sup>	11.2 <sup>6</sup>
Nominal CFM / ARI Rated CFM	2,400/2,100	3,000/2,625	3,400/3,000	4,000/3,200
ARI Net Cooling Capacity	70,000	90,000 <sup>10</sup>	98,000 <sup>10</sup>	109,000 <sup>10</sup>
Integrated Part Load Value (IPLV) <sup>3</sup>	–	11.9 <sup>8</sup>	12.1 <sup>8</sup>	12.0 <sup>8</sup>
System Power (kW)	6.09 <sup>7</sup>	7.83 <sup>7</sup>	8.52 <sup>7</sup>	9.73 <sup>7</sup>
<b>Compressor</b>				
No./Type	1/Climatuff Scroll	2/Climatuff Scrolls	2/Climatuff Scrolls	2/Climatuff Scrolls
<b>Outdoor Sound Rating (dB)<sup>4</sup></b>				
	89	91	89	88
<b>Outdoor Coil – Type</b>				
	Lanced	Lanced	Lanced	Lanced
Tube Size (in.) O.D.	0.3125	0.3125	0.3125	0.3125
Face Area (sq ft)	17.00	17.50	19.83	27.21
Rows/FPI	3/17	3/17	3/17	3/17
<b>Indoor Coil – Type</b>				
	Lanced	Lanced	Lanced	Lanced
Tube Size (in.)	0.3125	0.3125	0.3125	0.3125
Face Area (sq ft)	9.89	12.36	12.36	12.36
Rows/FPI	3/16	3/16	4/16	5/16
Refrigerant Control	Short Orifice	Short Orifice	Short Orifice	Short Orifice
Drain Connection No./Size (in.)	1¾ NPT	1¾ NPT	1¾ NPT	1¾ NPT
<b>Outdoor Fan – Type</b>				
	Propeller	Propeller	Propeller	Propeller
No. Used/Diameter (in.)	1/26	1/26	1/26	1/26
Drive Type/No. Speeds	Direct/1	Direct/1	Direct/1	Direct/1
CFM	6100	6200	6600	7000
No. Motors/HP	1/0.70	1/0.70	1/0.75	1/0.75
Motor RPM	1075	1075	1075	1075
<b>Belt Drive Indoor Fan – Type</b>				
	FC Centrifugal	FC Centrifugal	FC Centrifugal	FC Centrifugal
No. Used	1	1	1	1
Diameter x Width (in.)	12 x 12	15 x 15	15 x 15	15 x 15
Drive Type/No. Speeds	Belt/Variable Speed	Belt/Variable Speed	Belt/Variable Speed	Belt/Variable Speed
No. Motors	1	1	1	1
Motor HP (Standard/Oversized)	1.00/2.00	2.00/3.00	2.00/3.00	3.00/5.00
Motor RPM (Standard/Oversized)	1750	1750	1750	1750/3450
Motor Frame Size	56	56	56	56
<b>Filters – Type Furnished<sup>9</sup></b>				
(No.) Size Recommended (in.)	Throwaway (4) 16 x 25 x 2	Throwaway (4) 20 x 25 x 2	Throwaway (4) 20 x 25 x 2	Throwaway (4) 20 x 25 x 2
<b>Optional Hot Gas Reheat Coil – Type</b>				
	–	Lanced	Lanced	Lanced
Tube Size (in.) OD	–	0.375	0.375	0.375
Face Area (sq. ft.)	–	5.19	5.19	5.19
Rows/FPI	–	2/16	2/16	2/16
<b>Refrigerant Charge (Lbs of R-22)<sup>5</sup></b>				
	10.7	6.4 Circuit 1 6.2 Circuit 2	7.4 Circuit 1 7.1 Circuit 2	11.0 Circuit 1 7.3 Circuit 2

Notes:

- Cooling Performance is rated at 95 F ambient, 80 F entering dry bulb, 67 F entering wet bulb. Gross capacity does not include the effect of fan motor heat. ARI capacity is net and includes the effect of fan motor heat. Units are suitable for operation to ±20% of nominal cfm. Certified in accordance with the Unitary Air-Conditioner Equipment certification program, which is based on ARI Standard 210/240.
- SEER is rated at ARI conditions and in accordance with DOE test procedures.
- Integrated Part Load Value is rated in accordance with ARI Standard 210/240 or 360. Units are rated at 80°F ambient, 80°F entering dry bulb, and 67°F entering wet bulb at ARI rated cfm.
- Outdoor Sound Rating shown is tested in accordance with ARI Standard 270. For more information refer to Table PD-60.
- Refrigerant charge is an approximate value. For a more precise value, see unit nameplate and service instructions.
- EER shown is for downflow airflow. EER for horizontal airflow: THC072A - 11.3, THC092A and THC102A - 11.3, THC120A - 10.7.
- System Power (kW) shown is for downflow airflow. System Power (kW) for horizontal airflow: THC072A - 6.2, THC092A - 7.88, THC102A - 8.58, THC120A - 10.09.
- Integrated Part Load Value (IPLV) shown is for downflow airflow. IPLV for horizontal airflow: THC092A - 11.5, THC102A - 11.6, THC120A - 11.5.
- Optional 2" Pleated Filters also available.
- Net Cooling Capacity shown is for downflow airflow. Net Cooling for horizontal airflow: THC092A - 89,000, THC102A - 97,000, THC120A - 108,000.



# Performance Data

# (3, 4 Ton) Standard Efficiency

**Table PD-1 — Gross Cooling Capacities (MBH) 3 Ton Single/Three Phase TSC036A1, A3, A4, AW**

		Ambient Temperature (F)																							
		85				95				105				115											
CFM Airflow	Enter. Dry Bulb (F)	Entering Wet Bulb (F)																							
		61			67			73			61			67			73								
		MBH	SHC	MBH	SHC	MBH	SHC	MBH	SHC	MBH	SHC	MBH	SHC	MBH	SHC	MBH	SHC	MBH	SHC						
1080	75	34.6	29.0	38.6	22.3	40.6	14.7	31.2	27.3	36.6	21.1	39.5	13.8	28.2	25.6	33.4	19.6	37.8	12.9	25.1	24.1	29.6	18.2	35.5	11.9
	80	35.6	35.0	38.8	27.3	41.0	20.2	32.6	32.6	36.8	26.6	39.8	19.5	30.0	30.0	33.5	25.2	38.0	18.5	27.3	27.3	29.9	23.5	35.6	17.5
	85	37.6	37.6	39.2	32.5	41.5	24.7	35.6	35.6	37.2	32.2	40.1	24.2	32.8	32.8	34.2	31.0	38.2	23.8	30.1	30.1	30.7	29.3	35.8	23.0
	90	39.3	39.3	39.7	37.6	42.0	29.2	37.8	37.8	37.9	37.6	40.4	29.1	35.7	35.7	35.7	35.7	38.5	28.9	33.0	33.0	32.9	32.9	36.0	28.4
1200	75	35.6	30.9	39.0	22.8	40.9	14.9	32.2	29.2	37.3	22.1	39.8	14.1	29.0	27.5	34.3	20.7	38.2	13.1	25.9	25.9	30.4	19.0	36.0	12.1
	80	36.7	36.7	39.3	28.4	41.4	20.6	34.3	34.3	37.4	28.1	40.2	20.3	31.4	31.4	34.5	26.9	38.4	19.3	28.6	28.6	30.7	25.2	36.1	18.3
	85	38.7	38.7	39.7	33.9	41.9	25.3	37.0	37.0	37.9	34.0	40.5	25.0	34.5	34.5	35.3	33.2	38.7	24.8	31.5	31.5	31.7	31.6	36.3	24.2
	90	40.2	40.2	40.4	39.2	42.3	30.1	38.8	38.8	38.8	38.8	40.9	30.2	37.1	37.1	37.0	37.0	39.1	30.3	34.6	34.6	34.6	34.6	36.6	30.0
1320	75	36.4	32.6	40.4	23.5	41.1	15.1	33.2	31.0	37.7	23.0	40.1	14.3	29.8	29.3	34.9	21.8	38.5	13.4	26.8	26.8	30.9	20.0	36.3	12.4
	80	37.7	37.7	39.7	29.4	41.6	20.9	35.7	35.7	37.9	29.3	40.4	21.2	32.7	32.7	35.2	28.5	38.7	19.9	29.8	29.8	31.4	26.8	36.5	19.0
	85	39.4	39.4	40.2	35.2	42.1	25.9	37.9	37.9	38.5	35.6	40.8	25.7	35.9	35.9	36.2	35.3	39.1	25.7	32.9	32.9	32.9	32.9	36.7	25.3
	90	40.8	40.8	40.9	40.5	42.6	30.8	39.7	39.7	39.6	39.6	41.2	31.2	38.0	38.0	38.0	38.0	39.5	31.6	35.9	35.9	35.9	35.9	37.1	31.5
1440	75	37.0	34.1	39.7	24.0	41.3	15.3	34.1	32.8	38.0	23.7	40.3	14.5	30.6	30.6	35.5	22.7	38.7	13.6	27.7	27.7	31.4	21.0	36.6	12.6
	80	38.4	38.4	40.0	30.3	41.8	21.2	36.7	36.7	38.3	30.5	40.8	21.0	33.9	33.9	35.8	30.0	39.0	20.4	30.8	30.8	32.0	28.4	36.8	19.7
	85	40.0	40.0	40.6	36.3	42.4	26.4	38.7	38.7	39.0	37.0	41.2	26.7	36.8	36.8	36.8	36.8	39.4	26.6	34.2	34.2	34.2	34.2	37.0	26.4
	90	41.4	41.4	41.4	41.4	42.9	31.6	40.3	40.3	40.3	40.3	41.5	32.1	38.7	38.7	38.7	38.7	39.9	32.7	36.7	36.7	36.7	36.7	37.6	33.0

**Notes:**

- All capacities shown are gross and have not considered indoor fan heat. To obtain **NET** cooling capacity subtract indoor fan heat. For indoor fan heat formula, refer to appropriate airflow table notes.
- MBH = Total Gross Capacity
- SHC = Sensible Heat Capacity

**Table PD-2 — Gross Cooling Capacities (MBH) 4 Ton Single Phase TSC048A1**

		Ambient Temperature (F)																							
		85				95				105				115											
CFM Airflow	Enter. Dry Bulb (F)	Entering Wet Bulb (F)																							
		61			67			73			61			67			73								
		MBH	SHC	MBH	SHC	MBH	SHC	MBH	SHC	MBH	SHC	MBH	SHC	MBH	SHC	MBH	SHC	MBH	SHC						
1440	75	45.5	38.7	52.4	30.0	56.4	20.1	41.6	36.6	49.0	28.3	54.4	18.9	37.6	34.5	44.4	26.7	51.8	17.5	33.5	32.3	39.8	24.5	48.0	15.8
	80	46.5	46.5	52.5	37.6	56.8	28.1	43.2	43.2	49.1	35.9	54.8	26.7	39.9	39.9	44.6	33.8	52.0	25.2	36.5	36.5	40.1	31.6	48.2	23.4
	85	50.3	50.3	53.0	45.1	57.4	34.9	47.0	47.0	49.7	43.7	55.0	33.9	43.6	43.6	45.3	41.6	52.2	32.8	40.2	40.2	41.0	39.5	48.3	31.0
	90	53.3	53.3	53.8	52.5	57.7	41.1	50.8	50.8	50.8	50.8	55.5	41.0	47.5	47.5	47.5	47.5	52.5	40.1	44.0	44.0	44.0	44.0	48.6	38.6
1600	75	46.8	41.3	53.1	31.3	56.9	20.5	42.7	39.1	50.1	29.7	55.0	19.2	38.7	37.0	45.4	27.5	52.4	17.9	34.4	34.4	40.8	25.4	48.9	16.3
	80	48.7	48.7	53.4	39.5	57.5	28.9	45.2	45.2	50.3	38.2	55.4	27.8	41.8	41.8	45.7	36.0	52.7	26.3	38.2	38.2	41.1	33.9	49.1	24.7
	85	52.2	52.2	53.9	47.5	58.1	36.1	49.3	49.3	51.0	46.7	55.7	35.3	45.7	45.7	46.7	44.7	52.9	34.5	42.1	42.1	42.1	42.1	49.2	33.0
	90	54.9	54.9	54.9	54.9	58.4	42.8	52.7	52.7	52.7	52.7	56.2	42.9	49.8	49.8	49.8	49.8	53.3	42.5	46.2	46.2	46.2	46.2	49.7	41.3
1760	75	48.1	43.8	53.6	32.5	57.3	20.8	43.8	41.6	50.8	31.1	55.5	19.6	39.8	39.5	46.3	29.0	52.9	18.2	35.8	35.8	41.5	26.7	49.6	16.7
	80	50.5	50.5	54.0	41.2	58.0	29.6	47.1	47.1	51.1	40.3	55.9	29.0	43.4	43.4	46.7	38.2	53.2	27.4	39.8	39.8	42.0	36.0	49.7	25.8
	85	53.6	53.6	54.8	49.8	58.6	37.1	51.1	51.1	52.0	49.4	56.3	36.6	47.7	47.7	48.1	47.9	53.5	36.1	43.9	43.9	43.9	43.9	49.9	34.9
	90	56.1	56.1	56.1	56.1	59.0	44.2	54.2	54.2	54.1	54.1	56.9	44.8	51.5	51.5	51.5	51.5	54.1	44.7	48.2	48.2	48.2	48.2	50.5	43.9
1920	75	49.1	46.3	54.2	33.5	57.7	21.2	44.9	44.0	51.5	32.4	55.9	20.0	40.7	40.7	47.1	30.4	53.3	18.6	37.0	37.0	42.2	28.1	50.1	17.0
	80	51.9	51.9	54.6	42.7	58.4	30.1	48.8	48.8	51.8	42.2	56.3	30.2	45.0	45.0	47.7	40.4	53.7	28.5	41.2	41.2	42.9	38.2	50.3	26.9
	85	54.7	54.7	55.5	51.8	59.1	38.1	52.5	52.5	52.9	51.8	56.8	37.8	49.4	49.4	49.4	49.4	54.1	37.6	45.5	45.5	45.5	45.5	50.5	36.6
	90	57.1	57.1	57.1	57.1	59.4	45.6	55.3	55.3	55.3	55.3	57.4	46.4	52.8	52.8	52.8	52.8	54.7	46.7	49.8	49.8	49.8	49.8	51.3	46.2

**Notes:**

- All capacities shown are gross and have not considered indoor fan heat. To obtain **NET** cooling capacity subtract indoor fan heat. For indoor fan heat formula, refer to appropriate airflow table notes.
- MBH = Total Gross Capacity
- SHC = Sensible Heat Capacity



# Performance Data

# (4, 5 Ton) Standard Efficiency

**Table PD-3 — Gross Cooling Capacities (MBH) 4 Ton Three Phase TSC048A3, A4, AW**

		Ambient Temperature (F)																										
		85						95						105						115								
CFM Airflow	Enter. Dry Bulb (F)	Entering Wet Bulb (F)																										
		61			67			73			61			67			73			61			67			73		
		MBH	SHC	MBH	SHC	MBH	SHC	MBH	SHC	MBH	SHC	MBH	SHC	MBH	SHC	MBH	SHC	MBH	SHC	MBH	SHC	MBH	SHC	MBH	SHC			
1440	75	44.8	38.6	51.4	29.8	56.1	20.1	41.0	36.6	48.2	28.2	53.7	18.9	37.3	34.7	44.2	26.4	50.8	17.6	33.4	32.7	39.6	25.2	47.1	16.0			
	80	46.0	46.0	51.6	37.4	56.5	27.9	42.9	42.9	48.3	35.8	54.0	26.6	39.7	39.7	44.4	34.0	51.0	25.2	36.4	36.4	40.0	32.0	47.2	23.6			
	85	49.6	49.6	52.0	44.8	56.7	34.8	46.8	46.8	48.9	43.6	54.2	34.0	43.6	43.6	45.1	41.8	51.2	32.7	40.3	40.3	41.0	39.8	47.4	31.1			
	90	52.5	52.5	52.9	52.2	57.2	41.6	50.2	50.2	50.1	50.1	54.6	41.1	47.2	47.2	47.2	47.2	51.5	40.1	43.9	43.9	43.9	43.9	47.7	38.6			
1600	75	46.1	41.1	52.1	31.1	56.7	20.5	42.1	39.0	49.1	29.6	54.4	19.3	38.3	37.1	45.1	27.8	51.5	18.0	34.3	34.3	40.6	25.7	47.9	16.5			
	80	48.1	48.1	52.4	39.3	57.2	29.0	44.9	44.9	49.2	37.9	54.7	27.7	41.5	41.5	45.4	36.2	51.7	26.3	38.1	38.1	41.0	34.2	48.0	24.8			
	85	51.4	51.4	53.0	47.3	57.7	36.7	48.7	48.7	50.0	46.4	55.0	35.5	45.6	45.6	46.3	44.8	51.9	34.6	42.1	42.1	42.1	42.1	48.2	33.0			
	90	54.2	54.2	54.2	54.2	58.0	43.5	51.9	51.9	51.9	51.9	55.4	43.2	49.1	49.1	49.1	49.1	52.3	42.5	45.9	45.9	45.9	45.9	48.7	41.3			
1760	75	47.2	43.5	52.8	32.3	57.3	20.9	43.3	41.5	49.8	30.9	54.9	19.7	39.1	39.1	45.8	29.1	52.0	18.3	35.6	35.6	41.3	27.1	48.5	16.8			
	80	49.7	49.7	53.1	41.0	57.8	30.1	46.7	46.7	50.1	40.0	55.3	28.8	43.3	43.3	46.2	38.3	52.3	27.4	39.7	39.7	41.8	36.3	48.7	25.9			
	85	52.8	52.8	53.8	49.7	58.1	37.7	50.3	50.3	51.0	49.1	55.6	37.0	47.2	47.2	47.2	47.2	52.5	36.1	43.7	43.7	43.7	43.7	48.9	34.9			
	90	55.5	55.5	55.5	55.5	58.7	45.3	53.4	53.4	53.4	53.4	56.1	45.2	50.7	50.7	50.7	50.7	53.1	44.7	47.6	47.6	47.6	47.6	49.5	43.8			
1920	75	48.2	45.8	53.3	33.4	57.8	21.3	44.4	43.8	50.4	32.1	55.4	20.0	40.3	40.3	46.5	30.4	52.5	18.6	36.6	36.6	41.9	28.3	49.0	17.2			
	80	51.0	51.0	53.7	42.7	58.3	31.1	48.1	48.1	50.7	41.9	55.7	29.6	44.7	44.7	47.0	40.3	52.8	28.4	41.1	41.1	42.6	38.3	49.2	26.9			
	85	53.9	53.9	54.6	51.8	58.6	38.7	51.6	51.6	51.9	51.5	56.2	38.4	48.6	48.6	48.6	48.6	53.1	37.7	45.2	45.2	45.2	45.2	49.4	36.6			
	90	56.6	56.6	56.6	56.6	59.3	47.0	54.6	54.6	54.5	54.5	56.8	47.1	52.0	52.0	52.0	52.0	53.8	46.9	49.0	49.0	49.0	49.0	50.3	46.1			

Notes:

- All capacities shown are gross and have not considered indoor fan heat. To obtain **NET** cooling capacity subtract indoor fan heat. For indoor fan heat formula, refer to appropriate airflow table notes.
- MBH = Total Gross Capacity
- SHC = Sensible Heat Capacity

**Table PD-4 — Gross Cooling Capacities (MBH) 5 Ton Single/Three Phase TSC060A1, A3, A4, AW, AK**

		Ambient Temperature (F)																										
		85						95						105						115								
CFM Airflow	Enter. Dry Bulb (F)	Entering Wet Bulb (F)																										
		61			67			73			61			67			73			61			67			73		
		MBH	SHC	MBH	SHC	MBH	SHC	MBH	SHC	MBH	SHC	MBH	SHC	MBH	SHC	MBH	SHC	MBH	SHC	MBH	SHC	MBH	SHC	MBH	SHC			
1800	75	57.4	49.1	64.8	37.9	69.2	25.3	53.3	47.0	61.8	36.3	67.2	24.1	49.4	45.0	57.6	34.3	64.3	22.8	45.2	42.9	52.4	32.7	60.6	21.2			
	80	59.0	59.0	65.1	47.1	69.8	35.0	55.6	55.6	62.0	45.7	67.6	33.8	52.2	52.2	57.8	43.9	64.6	32.3	48.6	48.6	52.8	41.6	60.8	30.6			
	85	63.1	63.1	65.7	56.2	70.2	42.9	60.3	60.3	62.7	55.3	68.0	42.3	56.8	56.8	58.9	53.6	64.9	41.3	52.9	52.9	54.0	51.4	61.0	39.9			
	90	66.4	66.4	66.9	65.2	70.8	51.0	64.1	64.1	64.1	64.1	68.5	50.8	61.1	61.1	61.1	61.1	65.4	50.1	57.5	57.5	57.5	57.5	61.5	49.0			
2000	75	59.0	52.2	65.7	39.4	69.8	25.7	54.9	50.1	62.8	37.9	67.8	24.6	50.7	48.0	58.9	36.1	64.9	23.2	46.5	45.9	53.5	33.8	61.3	21.6			
	80	61.3	61.3	66.0	49.2	70.2	35.6	58.1	58.1	63.1	48.2	68.1	34.8	54.4	54.4	59.2	46.6	65.3	33.7	50.6	50.6	54.0	44.3	61.5	32.0			
	85	65.1	65.1	66.8	59.1	70.9	44.2	62.5	62.5	64.0	58.5	68.7	43.8	59.3	59.3	60.4	57.3	65.7	43.1	55.2	55.2	55.8	55.2	61.8	41.9			
	90	68.1	68.1	68.0	68.0	71.6	52.9	65.9	65.9	65.9	65.9	69.4	52.9	63.1	63.1	63.1	63.1	66.3	52.5	59.7	59.7	59.7	59.7	62.4	51.7			
2200	75	60.3	55.2	66.3	40.6	70.2	26.1	56.3	53.1	63.6	39.5	68.2	25.0	52.0	51.0	59.9	37.8	65.4	23.6	47.7	47.7	54.5	35.4	61.8	22.0			
	80	63.1	63.1	66.8	51.2	70.8	37.9	60.2	60.2	64.0	50.5	68.7	35.6	56.5	56.5	60.3	49.1	65.8	34.6	52.4	52.4	55.2	46.9	62.1	33.3			
	85	66.5	66.5	67.7	61.6	71.5	45.4	64.2	64.2	65.0	61.3	69.4	45.2	61.2	61.2	61.7	60.5	66.4	44.7	57.3	57.3	57.3	57.3	62.5	43.8			
	90	69.4	69.4	69.3	69.3	72.2	54.6	67.3	67.3	67.3	67.3	70.1	54.9	64.6	64.6	64.6	64.6	67.1	54.8	61.2	61.2	61.2	61.2	63.2	54.2			
2400	75	61.5	58.0	66.9	41.8	70.6	26.5	57.6	56.0	64.2	40.8	68.6	25.4	53.0	53.0	60.6	39.3	65.9	24.0	49.1	49.1	55.4	37.1	62.2	22.4			
	80	64.5	64.5	67.5	53.0	71.2	38.8	61.8	61.8	64.7	52.5	69.1	36.4	58.3	58.3	61.1	51.4	66.3	35.5	53.9	53.9	56.3	49.5	62.5	34.3			
	85	67.7	67.7	68.5	63.9	72.0	46.5	65.4	65.4	65.9	63.9	69.9	46.5	62.5	62.5	62.5	62.5	66.9	46.2	58.9	58.9	58.9	58.9	63.0	45.5			
	90	70.4	70.4	70.4	70.4	72.8	56.1	68.4	68.4	68.4	68.4	70.6	56.6	65.8	65.8	65.8	65.8	67.7	56.8	62.4	62.4	62.4	62.4	63.9	56.5			

Notes:

- All capacities shown are gross and have not considered indoor fan heat. To obtain **NET** cooling capacity subtract indoor fan heat. For indoor fan heat formula, refer to appropriate airflow table notes.
- MBH = Total Gross Capacity
- SHC = Sensible Heat Capacity



# Performance Data

# (6, 7½ Ton) Standard Efficiency

**Table PD-5 — Gross Cooling Capacities (MBH) 6 Ton Three Phase TSC072A3, A4, AW, AK**

CFM Airflow		Ambient Temperature (F)																							
		85			95						105			115											
		Entering Wet Bulb (F)																							
Enter. Dry Bulb (F)																									
61																									
67																									
73																									
61																									
67																									
73																									
61																									
67																									
73																									
61																									
67																									
73																									
61																									
67																									
73																									
2160	75	65.9	55.0	73.4	43.5	76.7	28.3	61.0	52.5	70.7	40.9	75.4	27.3	56.3	50.1	66.3	38.8	73.2	26.0	51.7	47.7	60.9	36.4	70.3	24.6
	80	67.6	66.2	73.7	52.2	77.5	38.9	63.2	63.2	70.9	51.1	76.0	37.8	59.2	59.2	66.4	49.1	73.7	36.4	55.3	55.3	61.0	46.6	70.6	34.9
	85	71.4	71.4	74.2	61.9	78.6	47.4	68.5	68.5	71.4	61.3	76.5	46.6	64.4	64.4	67.3	59.7	74.0	46.0	60.4	60.4	62.2	57.3	70.8	45.0
	90	74.6	74.6	75.3	71.3	79.3	55.7	72.4	72.4	72.8	71.3	77.2	55.5	69.5	69.5	69.5	69.5	74.6	55.4	65.7	65.7	65.6	65.6	71.2	54.8
2400	75	67.7	58.3	74.0	43.8	77.1	28.7	62.9	55.9	71.7	42.6	75.9	27.7	57.9	53.4	67.9	40.8	73.7	26.4	53.2	51.0	62.4	38.3	70.9	25.0
	80	69.7	69.7	74.6	54.1	78.0	39.5	66.2	66.2	72.0	53.6	76.6	39.2	61.8	61.8	68.0	52.0	74.3	37.9	57.8	57.8	62.6	49.6	71.3	36.3
	85	73.4	73.4	75.3	64.5	79.0	48.2	70.9	70.9	72.7	64.5	77.2	47.9	67.4	67.4	69.1	63.6	74.8	47.6	63.2	63.2	64.2	61.4	71.7	47.0
	90	76.2	76.2	76.5	74.3	79.9	57.1	74.3	74.3	74.3	74.3	77.9	57.4	71.7	71.7	71.7	71.7	75.5	57.7	68.5	68.5	68.4	68.4	72.2	57.5
2640	75	69.1	61.4	74.7	44.9	77.4	29.0	64.5	59.1	72.5	44.3	76.2	28.1	59.4	56.6	69.0	42.5	74.2	26.9	54.7	54.2	63.6	40.1	71.3	25.4
	80	71.6	71.6	75.3	55.8	78.4	40.0	68.6	68.6	72.8	55.8	77.0	41.1	64.2	64.2	69.1	54.7	74.6	38.6	60.0	60.0	63.9	52.4	71.9	37.7
	85	74.8	74.8	76.1	66.8	79.4	49.1	72.7	72.7	73.8	67.3	77.8	49.3	69.7	69.7	70.5	66.9	75.4	49.1	65.7	65.7	66.1	65.4	72.3	48.7
	90	77.4	77.4	77.5	76.8	80.3	58.4	75.8	75.8	75.8	75.8	78.5	59.0	73.4	73.4	73.3	73.3	76.2	59.7	70.5	70.5	70.5	70.5	73.0	59.8
2880	75	70.2	64.1	75.2	45.8	77.6	29.4	66.1	62.3	73.1	45.4	76.5	28.5	60.9	59.7	69.8	44.2	74.5	27.3	56.2	56.2	64.7	41.9	71.7	25.8
	80	72.9	72.9	75.9	57.4	78.7	40.4	70.3	70.3	73.6	57.8	77.3	41.8	66.5	66.5	70.1	57.1	75.2	41.1	62.0	62.0	65.2	55.2	72.1	38.5
	85	75.9	75.9	76.8	68.8	79.7	49.9	74.0	74.0	74.7	69.8	78.5	50.6	71.3	71.3	71.6	69.8	75.9	50.4	67.8	67.8	67.7	67.7	72.9	50.1
	90	78.3	78.3	78.3	78.3	80.7	59.6	76.8	76.8	76.8	76.8	79.0	60.5	74.6	74.6	74.6	74.6	76.7	61.6	71.9	71.9	71.9	71.9	73.7	61.9

**Notes:**

1. All capacities shown are gross and have not considered indoor fan heat. To obtain **NET** cooling capacity subtract indoor fan heat. For indoor fan heat formula, refer to appropriate airflow table notes.
2. MBH = Total Gross Capacity
3. SHC = Sensible Heat Capacity

**Table PD-6 — Gross Cooling Capacities (MBH) 7½ Ton Three Phase Single Compressor TSC090A3, A4, AW, AK**

CFM Airflow		Ambient Temperature (F)																							
		85			95						105			115											
		Entering Wet Bulb (F)																							
Enter. Dry Bulb (F)																									
61																									
67																									
73																									
61																									
67																									
73																									
61																									
67																									
73																									
61																									
67																									
73																									
2700	75	87.4	73.8	96.2	56.7	98.8	36.7	80.6	70.3	93.3	54.3	98.8	35.6	73.5	66.6	86.9	51.2	96.8	33.9	66.6	63.1	78.4	48.2	92.8	31.8
	80	89.6	88.9	96.6	68.7	100.0	49.9	83.4	83.4	93.5	68.3	99.9	50.2	77.6	77.6	87.2	65.3	97.4	48.2	71.6	71.6	78.9	61.5	92.9	46.0
	85	94.2	94.2	97.5	81.6	101.2	60.4	90.4	90.4	94.4	82.2	100.9	61.9	84.8	84.8	88.5	79.8	97.8	61.4	78.5	78.5	80.7	76.2	93.2	59.9
	90	98.0	98.0	98.7	93.9	102.3	71.0	95.8	95.8	96.2	95.8	101.2	72.9	91.6	91.6	91.6	91.6	98.5	74.3	86.0	86.0	86.0	86.0	93.7	73.5
3000	75	89.7	78.4	96.7	57.3	99.1	37.2	83.0	75.0	94.6	56.7	99.2	36.1	75.8	71.3	88.9	53.9	97.5	34.5	68.7	67.7	80.3	50.1	93.8	32.5
	80	92.2	92.2	97.5	70.9	100.3	50.4	87.4	87.4	95.0	71.8	100.4	50.9	81.4	81.4	89.3	69.5	98.3	50.3	75.0	75.0	81.1	65.8	94.1	48.1
	85	96.5	96.5	98.5	84.4	101.5	61.2	93.8	93.8	96.1	86.6	101.6	63.4	88.9	88.9	91.0	85.5	98.8	63.7	82.5	82.5	83.7	82.1	94.4	63.1
	90	99.5	99.5	99.9	97.0	102.6	72.3	98.2	98.2	98.2	98.2	101.9	75.0	94.9	94.9	94.9	94.9	99.7	77.4	90.1	90.1	90.0	90.0	95.3	77.7
3300	75	91.5	82.5	97.7	59.0	99.3	37.7	85.2	79.6	95.5	58.8	99.5	36.6	78.0	76.0	90.5	56.5	98.0	35.1	70.5	70.5	82.1	52.8	94.5	33.2
	80	94.4	94.4	98.1	72.8	100.5	55.0	90.7	90.7	96.2	74.8	100.8	51.6	84.7	84.7	91.1	73.5	98.9	51.5	78.0	78.0	83.2	70.0	95.0	50.1
	85	98.0	98.0	99.2	86.8	101.7	62.0	96.1	96.1	97.5	90.5	102.0	64.7	92.0	92.0	93.1	90.6	99.5	65.6	86.2	86.2	86.2	86.2	95.4	65.8
	90	100.5	100.5	100.7	99.4	102.8	73.4	99.9	99.9	99.9	99.9	102.4	76.8	97.2	97.2	97.2	97.2	100.5	80.1	93.0	93.0	93.0	93.0	96.5	81.4
3600	75	92.9	86.2	98.1	59.9	99.4	38.2	87.3	84.1	96.3	60.6	99.8	37.2	79.6	79.6	91.7	58.9	98.3	35.7	72.9	72.9	83.7	55.4	95.1	33.8
	80	96.0	96.0	98.6	74.3	100.7	56.8	93.1	93.1	97.1	77.5	101.0	55.7	87.6	87.6	92.5	77.2	99.5	52.7	80.7	80.7	85.1	74.1	95.5	51.6
	85	99.0	99.0	99.7	88.7	101.8	62.7	97.8	97.8	98.6	93.7	102.3	65.8	94.4	94.4	94.4	94.4	100.0	67.3	89.1	89.1	89.1	89.1	96.3	68.3
	90	101.1	101.1	101.1	101.1	103.0	74.4	101.0	101.0	101.0	101.0	102.8	78.4	98.9	98.9	98.9	98.9	101.2	82.4	95.1	95.1	95.1	95.1	97.5	84.6

**Notes:**

1. All capacities shown are gross and have not considered indoor fan heat. To obtain **NET** cooling capacity subtract indoor fan heat. For indoor fan heat formula, refer to appropriate airflow table notes.
2. MBH = Total Gross Capacity
3. SHC = Sensible Heat Capacity



# Performance Data

# (7½, 8½ Ton) Standard Efficiency

**Table PD-7 — Gross Cooling Capacities (MBH) 7½ Ton Three Phase Dual Compressors TSC092A3, A4, AW**

CFM Airflow		Ambient Temperature (F)																							
		85				95				105				115											
		Enter. Dry Bulb (F)		61		67		73		Enter. Wet Bulb (F)		61		67		73		61		67		73			
		MBH	SHC	MBH	SHC	MBH	SHC	MBH	SHC	MBH	SHC	MBH	SHC	MBH	SHC	MBH	SHC	MBH	SHC	MBH	SHC				
2700	75	84.6	72.9	93.9	55.3	98.4	36.4	78.2	69.6	90.1	53.3	96.9	35.1	71.8	66.3	83.9	50.4	94.0	33.3	65.3	63.1	76.5	47.1	89.4	31.2
	80	86.8	86.8	94.4	68.5	99.6	50.0	81.8	81.8	90.5	67.5	98.0	49.7	76.4	76.4	84.3	64.7	94.5	47.5	70.9	70.9	77.1	61.4	89.6	45.3
	85	92.2	92.2	95.4	81.7	100.8	61.3	88.4	88.4	91.5	81.5	99.0	62.4	83.2	83.2	85.8	79.3	94.9	60.9	77.6	77.6	79.0	76.1	89.9	59.3
	90	96.3	96.3	96.9	94.4	102.0	72.8	93.6	93.6	93.6	93.6	99.3	73.4	89.6	89.6	89.6	89.6	95.8	74.0	84.5	84.5	84.5	84.5	90.6	73.0
3000	75	86.8	77.5	94.7	57.0	98.9	37.1	80.5	74.4	91.5	55.8	97.6	35.7	74.0	71.1	85.6	53.1	94.8	34.0	67.1	67.1	78.2	49.8	90.5	31.9
	80	90.1	90.1	95.6	71.2	100.2	50.8	85.4	85.4	92.0	71.1	98.7	50.7	79.9	79.9	86.3	68.9	95.5	49.6	74.1	74.1	79.1	65.7	90.8	47.4
	85	94.7	94.7	96.8	85.3	101.4	62.7	91.5	91.5	93.3	86.2	99.7	63.7	86.9	86.9	88.2	84.9	96.1	63.5	81.3	81.3	81.2	81.2	91.2	62.6
	90	98.3	98.3	98.3	98.3	102.7	74.8	96.2	96.2	96.1	96.1	100.3	76.2	92.7	92.7	92.7	92.7	97.1	77.5	88.0	88.0	88.0	88.0	92.2	77.4
3300	75	88.7	81.9	95.7	58.9	99.3	37.6	82.6	79.0	92.5	58.2	98.1	36.2	75.5	75.5	87.1	55.7	95.4	34.6	69.6	69.6	79.6	52.4	91.3	32.5
	80	92.3	92.3	96.5	73.7	100.7	51.5	88.4	88.4	93.2	74.4	99.3	51.7	82.9	82.9	87.9	72.8	96.1	51.0	76.9	76.9	80.8	69.8	91.7	49.5
	85	96.5	96.5	97.8	88.4	102.0	63.9	93.8	93.8	94.8	90.3	100.0	65.0	89.8	89.8	89.8	89.8	96.9	65.8	84.4	84.4	84.4	84.4	92.3	65.5
	90	99.7	99.7	99.7	99.7	103.3	76.5	98.0	98.0	98.0	101.1	78.5	94.9	94.9	94.9	94.9	98.1	80.6	90.7	90.7	90.7	90.7	93.5	81.3	
3600	75	90.2	85.7	96.4	60.6	99.7	38.1	84.6	83.6	93.3	60.0	98.5	36.8	77.9	77.9	88.2	58.1	96.0	35.2	71.8	71.8	80.9	55.0	92.0	33.2
	80	94.0	94.0	97.2	75.8	101.0	52.1	90.7	90.7	94.3	77.4	99.7	52.6	85.6	85.6	89.2	76.6	96.6	52.0	79.5	79.5	82.3	73.8	92.5	51.5
	85	97.8	97.8	98.7	91.1	102.4	65.0	95.6	95.6	96.1	93.9	100.5	66.3	91.9	91.9	91.9	91.9	97.6	67.9	86.9	86.9	86.9	86.9	93.1	68.2
	90	100.8	100.8	100.8	100.8	103.7	78.1	99.3	99.3	99.3	101.7	80.7	96.6	96.6	96.6	96.6	98.9	83.4	92.7	92.7	92.7	92.7	94.6	84.9	

Notes:

- All capacities shown are gross and have not considered indoor fan heat. To obtain **NET** cooling capacity subtract indoor fan heat. For indoor fan heat formula, refer to appropriate airflow table notes.
- MBH = Total Gross Capacity
- SHC = Sensible Heat Capacity

**Table PD-8 — Gross Cooling Capacities (MBH) 8½ Ton Three Phase TSC102A3, A4, AW, AK**

CFM Airflow		Ambient Temperature (F)																							
		85				95				105				115											
		Enter. Dry Bulb (F)		61		67		73		Enter. Wet Bulb (F)		61		67		73		61		67		73			
		MBH	SHC	MBH	SHC	MBH	SHC	MBH	SHC	MBH	SHC	MBH	SHC	MBH	SHC	MBH	SHC	MBH	SHC	MBH	SHC				
3060	75	96.3	82.3	106.6	62.7	112.5	41.5	89.0	78.5	103.2	60.6	110.9	40.0	81.8	74.9	96.6	57.5	107.6	38.1	74.9	71.3	87.6	55.2	102.5	35.8
	80	98.0	98.0	107.2	77.1	113.7	57.0	92.9	91.4	104.3	76.3	111.5	57.1	86.3	86.2	96.9	73.3	108.2	54.0	80.2	80.2	88.1	69.4	102.8	51.5
	85	103.9	103.9	108.1	91.7	114.8	69.6	100.1	100.1	104.3	91.7	112.4	70.0	94.3	94.3	98.3	89.5	108.6	68.9	87.6	87.6	89.9	85.7	103.1	67.1
	90	108.6	108.6	109.6	105.7	116.0	82.4	105.9	105.9	105.9	105.9	113.2	83.0	101.6	101.6	101.9	100.2	109.3	83.4	95.6	95.6	95.6	95.5	103.6	82.3
3400	75	98.7	87.2	107.8	65.9	113.0	42.0	91.8	83.8	104.7	63.7	111.8	40.7	84.2	80.0	98.7	60.5	108.6	38.9	76.3	76.3	89.6	58.6	103.7	36.5
	80	101.6	100.0	108.5	80.1	114.6	58.1	96.9	96.5	105.0	80.1	112.8	57.8	90.3	90.3	99.1	77.9	109.3	56.3	83.8	83.8	90.3	74.0	104.0	53.8
	85	106.8	106.8	109.6	95.7	115.8	71.4	103.6	103.6	106.2	96.7	114.0	70.7	98.7	98.7	100.9	95.5	109.8	71.7	91.7	91.7	91.7	91.7	104.3	70.7
	90	111.0	111.0	111.0	111.0	117.0	84.9	108.8	108.8	108.9	107.2	114.4	86.1	105.1	105.1	105.0	104.8	110.7	87.4	99.8	99.8	99.7	99.7	105.2	87.1
3740	75	100.7	91.7	109.2	64.5	114.0	42.8	93.8	88.7	106.1	66.5	113.5	41.7	85.4	85.4	100.4	63.3	109.4	39.6	79.4	77.5	91.3	59.4	104.6	37.2
	80	104.1	103.6	109.6	82.9	115.3	59.0	100.0	100.0	106.6	84.3	113.7	59.0	94.0	94.0	100.9	82.2	109.6	60.2	87.0	87.0	92.2	78.5	105.1	56.0
	85	108.9	108.9	110.9	99.2	116.6	73.0	106.7	106.7	108.3	102.4	114.8	74.4	102.0	102.0	102.0	102.0	110.8	74.3	95.6	95.6	96.4	93.7	105.5	73.9
	90	112.8	112.8	112.8	112.8	117.8	87.2	111.8	111.8	111.8	111.8	116.0	90.0	107.7	107.7	107.7	111.9	90.9	102.9	102.9	102.9	102.9	106.6	91.4	
4080	75	102.3	95.8	110.2	66.1	114.6	43.5	95.2	95.2	106.7	68.3	113.1	42.2	88.2	88.2	101.6	65.9	110.1	40.3	81.6	80.6	92.7	62.1	105.3	38.1
	80	106.2	106.2	110.5	85.3	115.9	59.8	102.8	102.8	107.4	86.8	114.3	60.0	97.4	97.4	102.4	86.2	111.0	58.6	89.9	89.9	94.1	82.9	105.9	58.2
	85	110.5	110.5	111.9	102.3	117.2	74.4	108.3	108.3	109.2	105.1	115.5	76.3	104.5	104.5	104.4	104.4	111.5	77.2	98.7	98.7	99.0	97.4	106.4	76.8
	90	114.2	114.2	114.2	114.2	118.5	89.3	112.7	112.7	112.7	112.7	116.8	92.7	109.7	109.7	109.7	109.7	112.9	94.2	105.2	105.2	105.2	105.2	107.8	95.4

Notes:

- All capacities shown are gross and have not considered indoor fan heat. To obtain **NET** cooling capacity subtract indoor fan heat. For indoor fan heat formula, refer to appropriate airflow table notes.
- MBH = Total Gross Capacity
- SHC = Sensible Heat Capacity



# Performance Data

# (10 Ton) Standard Efficiency

**Table PD-9 – Gross Cooling Capacities (MBH) 10 Ton Three Phase TSC120A3, A4, AW, AK**

		Ambient Temperature (F)																											
		85						95						105						115									
CFM Airflow	Enter. Dry Bulb (F)	Entering Wet Bulb (F)																											
		61			67			73			61			67			73			61			67			73			
		MBH	SHC	MBH	SHC	MBH	SHC	MBH	SHC	MBH	SHC	MBH	SHC	MBH	SHC	MBH	SHC	MBH	SHC	MBH	SHC	MBH	SHC	MBH	SHC	MBH	SHC		
3600	75	108.6	95.7	120.5	71.5	126.0	46.0	100.1	91.3	115.5	68.8	123.6	43.3	91.0	86.5	107.2	64.9	119.3	41.0	82.2	82.0	96.5	60.1	113.1	37.9				
	80	112.8	112.8	121.2	89.2	127.5	65.7	106.3	106.3	116.1	88.1	124.8	62.8	98.5	98.5	108.2	84.5	120.1	60.5	90.5	90.5	97.8	79.7	113.6	57.4				
	85	119.5	119.5	122.6	106.9	129.0	78.5	114.8	114.8	117.7	107.0	126.2	79.2	108.2	108.2	110.5	104.5	121.8	76.8	100.1	100.1	100.1	100.1	114.2	76.6				
	90	124.3	124.3	124.6	123.6	130.4	93.6	121.0	121.0	121.0	121.0	127.6	95.7	116.0	116.0	116.0	116.0	122.0	95.1	109.4	109.4	109.4	109.4	115.3	94.5				
4000	75	111.6	102.3	121.7	73.9	126.7	46.9	103.4	98.1	117.1	72.3	124.5	42.7	94.2	93.4	109.5	68.7	120.2	41.9	85.3	85.3	98.8	64.0	114.3	38.8				
	80	116.7	116.7	122.6	92.7	128.2	64.5	111.1	111.1	118.0	93.0	125.7	64.2	103.4	103.4	110.8	90.4	121.4	63.2	95.0	95.0	100.6	85.8	114.9	60.3				
	85	122.3	122.3	124.2	111.4	129.7	80.2	118.5	118.5	120.0	113.1	127.1	81.6	112.8	112.8	113.6	112.1	122.6	82.1	105.1	105.1	105.1	105.1	115.6	80.4				
	90	126.9	126.9	126.4	126.4	131.3	96.0	123.7	123.7	123.7	123.7	128.7	99.0	119.3	119.3	119.3	119.3	124.1	100.7	113.4	113.4	113.4	113.4	117.1	100.0				
4400	75	114.1	108.4	122.5	75.8	127.3	47.7	106.5	104.9	118.4	75.8	124.9	45.4	97.1	97.1	111.3	72.3	121.3	40.2	88.6	88.6	100.9	67.7	115.1	39.7				
	80	119.5	119.5	123.8	96.1	128.9	65.5	114.7	114.7	119.5	97.3	126.3	69.2	107.7	107.7	112.9	95.9	122.2	64.9	99.0	99.0	103.1	91.7	115.8	63.2				
	85	124.9	124.9	125.5	115.5	130.4	81.9	121.1	121.1	121.8	118.3	127.9	83.7	116.0	116.0	116.0	116.0	123.6	85.0	109.2	109.2	109.2	109.2	116.8	84.0				
	90	127.9	127.9	128.0	128.0	132.0	98.3	126.1	126.1	125.6	125.6	129.5	101.8	121.7	121.7	121.7	121.7	125.3	104.7	116.2	116.2	116.2	116.2	118.5	104.7				
4800	75	116.1	113.8	123.1	77.6	127.8	48.5	108.9	108.9	119.2	78.1	125.4	46.2	100.5	100.5	112.8	76.1	121.4	43.6	91.6	91.6	102.6	71.3	115.8	40.6				
	80	121.4	121.4	124.5	98.6	129.4	66.4	117.3	117.3	120.8	101.1	126.9	66.5	111.1	111.1	114.6	100.9	122.9	66.4	102.5	102.5	105.4	97.5	116.5	65.7				
	85	126.0	126.0	126.4	118.6	130.9	83.4	122.9	122.9	123.2	122.6	128.5	85.6	118.4	118.4	118.4	118.4	124.3	87.5	112.1	112.1	112.1	112.1	117.8	87.3				
	90	129.1	129.1	129.1	129.1	132.5	100.4	127.2	127.2	126.9	126.9	130.2	104.4	124.0	124.0	123.7	123.7	126.2	108.0	118.2	118.2	118.2	118.2	119.7	108.9				

**Notes:**

1. All capacities shown are gross and have not considered indoor fan heat. To obtain **NET** cooling capacity subtract indoor fan heat. For indoor fan heat formula, refer to appropriate airflow table notes.
2. MBH = Total Gross Capacity
3. SHC = Sensible Heat Capacity



# Performance Data

# (3 Ton) High Efficiency

**Table PD-10 — Gross Cooling Capacities (MBH) 3 Ton THC036A1, A3, A4, AW- Standard Refrigeration Option**

CFM Airflow		Ambient Temperature (F)																							
		85						95						105						115					
		Enter. Dry Bulb (F)		61		67		73		Enter. Wet Bulb (F)		61		67		73		61		67		73			
MBH	SHC	MBH	SHC	MBH	SHC	MBH	SHC	MBH	SHC	MBH	SHC	MBH	SHC	MBH	SHC	MBH	SHC	MBH	SHC	MBH	SHC	MBH	SHC		
1080	75	34.2	29.2	39.8	22.7	43.1	15.2	31.1	27.4	37.0	21.2	41.3	14.1	28.0	25.7	33.3	19.8	39.0	12.9	24.8	24.0	29.8	18.1	36.1	11.6
	80	34.9	34.9	40.0	28.5	43.5	21.3	32.3	32.3	37.1	27.1	41.6	20.1	29.7	29.7	33.5	25.3	39.2	18.8	27.1	27.1	30.0	23.6	36.2	17.5
	85	37.9	37.9	40.3	34.3	44.0	26.5	35.3	35.3	37.5	33.0	41.9	25.6	32.6	32.6	34.0	31.3	39.5	24.6	30.0	30.0	30.6	29.6	36.4	23.2
	90	40.5	40.5	40.9	40.0	44.5	31.7	38.4	38.4	38.4	38.4	42.3	31.0	35.7	35.7	35.7	35.7	39.7	30.3	32.9	32.9	32.9	32.9	36.7	29.0
1200	75	35.3	31.2	40.4	23.7	43.5	15.5	32.0	29.4	37.8	22.4	41.8	14.4	28.8	27.7	34.1	20.6	39.5	13.2	25.5	25.5	30.5	18.8	36.7	11.9
	80	36.7	36.7	40.7	30.0	44.0	21.9	33.9	33.9	38.0	28.9	42.1	20.9	31.2	31.2	34.4	27.1	39.8	19.7	28.5	28.5	30.8	25.3	36.9	18.4
	85	39.6	39.6	41.1	36.3	44.6	27.4	37.1	37.1	38.5	35.4	42.5	26.8	34.3	34.3	35.1	33.8	40.0	26.0	31.5	31.5	31.5	31.5	37.1	24.8
	90	41.9	41.9	41.9	41.9	45.1	33.0	39.9	39.9	39.9	39.9	42.9	32.6	37.6	37.6	37.6	37.6	40.4	32.1	34.7	34.7	34.7	34.7	37.4	31.1
1320	75	36.2	33.2	40.9	24.7	43.8	15.8	32.8	31.4	38.4	23.4	42.1	14.7	29.4	29.4	34.8	21.7	39.9	13.5	26.5	26.5	31.0	19.9	37.2	12.2
	80	38.2	38.2	41.2	31.4	44.4	22.4	35.4	35.4	38.7	30.5	42.6	21.7	32.5	32.5	35.2	28.9	40.2	20.5	29.7	29.7	31.5	27.1	37.4	19.2
	85	40.8	40.8	41.8	38.1	45.0	28.3	38.7	38.7	39.4	37.6	43.1	28.0	35.9	35.9	36.2	36.2	40.5	27.2	32.9	32.9	32.9	32.9	37.6	26.2
	90	42.9	42.9	42.9	42.9	45.6	34.2	41.1	41.1	41.1	41.1	43.4	34.0	38.9	38.9	38.9	38.9	41.0	33.8	36.3	36.3	36.3	36.3	38.1	33.1
1440	75	37.1	35.1	41.3	25.5	44.1	16.1	33.6	33.3	38.9	24.4	42.4	15.0	30.4	30.4	35.5	22.8	40.2	13.8	27.5	27.5	31.5	21.0	37.5	12.5
	80	39.4	39.4	41.7	32.6	44.7	22.9	36.8	36.8	39.3	32.1	42.9	22.3	33.8	33.8	35.9	30.6	40.6	21.4	30.8	30.8	32.1	28.8	37.8	20.1
	85	41.7	41.7	42.4	39.7	45.3	29.0	39.8	39.8	40.1	39.5	43.5	29.0	37.3	37.3	37.3	37.3	40.9	28.3	34.2	34.2	34.2	34.2	38.0	27.6
	90	43.7	43.7	43.7	43.7	45.9	35.3	42.1	42.1	42.1	42.1	43.9	35.3	40.0	40.0	40.0	40.0	41.5	35.4	37.5	37.5	37.5	37.5	38.6	34.9

**Notes:**

1. All capacities shown are gross and have not considered indoor fan heat. To obtain **NET** cooling capacity subtract indoor fan heat. For indoor fan heat formula, refer to appropriate airflow table notes.
2. MBH = Total Gross Capacity
3. SHC = Sensible Heat Capacity





# Performance Data

## (3 Ton) High Efficiency

**Table PD-11 – Gross Cooling Capacities (MBH) 3 Ton THC036A1, A3, A4, AW – Dehumidification (Hot Gas Reheat) or TXV Option**

		Ambient Temperature (F)																							
		85			95			105			115														
CFM	Enter. Dry Bulb (F)	Entering Wet Bulb (F)																							
		61		67		73		61		67		73		61		67		73							
Airflow		MBH	SHC	MBH	SHC	MBH	SHC	MBH	SHC	MBH	SHC	MBH	SHC	MBH	SHC	MBH	SHC	MBH	SHC	MBH	SHC				
600*	75	30.8	21.6	34.9	178	39.2	13.7	28.9	20.4	32.8	16.6	37.0	12.5	26.9	19.1	30.6	15.3	34.7	11.3	24.8	17.8	28.4	14.1	32.3	10.0
	80	30.9	25.0	35.0	21.2	39.3	17.2	29.0	23.8	32.9	19.9	37.1	16.0	26.9	22.5	30.8	18.7	34.8	14.8	24.9	21.1	28.6	17.4	32.4	13.5
	85	31.0	28.4	35.1	24.6	39.5	20.6	29.0	27.1	33.1	23.3	37.3	19.3	27.0	25.8	30.9	22.0	35.0	18.1	25.0	24.5	28.7	20.7	32.6	16.8
	90	31.2	31.2	35.2	27.9	39.6	23.9	29.6	29.6	33.1	26.6	37.4	22.7	28.0	28.0	31.0	25.4	35.1	21.4	26.3	26.3	28.8	24.0	32.7	20.1
780*	75	33.1	24.8	37.3	19.7	41.8	14.5	30.9	23.5	35.0	18.5	39.3	13.2	28.8	22.2	32.6	17.1	36.7	12.0	26.5	20.8	30.2	15.8	34.1	10.7
	80	33.2	29.2	37.4	24.1	41.9	18.9	31.1	27.9	35.1	22.8	39.5	17.6	29.0	26.6	32.8	21.5	36.9	16.3	26.7	25.2	30.4	20.1	34.3	15.0
	85	33.4	33.4	37.5	28.4	42.1	23.2	31.6	31.6	35.3	27.1	39.6	21.9	29.8	29.8	32.9	25.8	37.0	20.6	27.9	27.9	30.5	24.4	34.4	19.3
	90	35.4	35.4	37.7	32.7	42.2	27.5	33.6	33.6	35.5	31.4	39.8	26.2	31.8	31.8	33.1	30.1	37.2	24.9	29.8	29.8	30.8	28.7	34.6	23.6
960	75	34.6	27.8	38.9	21.5	43.4	15.1	32.4	26.5	36.5	20.2	40.9	13.8	30.1	25.1	34.0	18.9	38.1	12.6	27.7	23.7	31.4	17.5	35.3	11.2
	80	35.0	33.2	39.0	26.8	43.5	20.4	32.8	31.9	36.6	25.5	41.0	19.2	30.6	30.5	34.1	24.1	38.3	17.8	28.3	28.3	31.6	22.7	35.5	16.5
	85	36.4	36.4	39.2	32.0	43.7	25.6	34.5	34.5	36.8	30.7	41.2	24.4	32.5	32.5	34.4	29.4	38.5	23.0	30.4	30.4	31.9	28.0	35.7	21.7
	90	38.6	38.6	39.6	37.3	43.9	30.8	36.7	36.7	37.3	36.0	41.4	29.5	34.6	34.6	34.9	34.7	38.6	28.2	32.5	32.5	32.5	32.5	35.9	26.8
1080	75	35.5	29.7	39.7	22.9	44.1	15.4	33.2	28.4	37.2	21.6	41.6	14.2	30.8	27.0	34.6	20.3	38.8	12.9	28.4	25.6	32.0	18.9	35.9	11.6
	80	36.0	35.8	39.9	28.5	44.3	21.3	33.8	33.8	37.4	27.2	41.7	20.1	31.7	31.7	34.8	25.8	39.0	18.8	29.6	29.6	32.2	24.4	36.1	17.4
	85	38.1	38.1	40.1	34.4	44.5	27.2	36.0	36.0	37.7	33.1	41.9	25.9	33.9	33.9	35.2	31.7	39.2	24.6	31.8	31.8	32.6	30.3	36.3	23.2
	90	40.4	40.4	40.8	40.4	44.7	33.0	38.3	38.3	38.3	38.3	42.1	31.7	36.2	36.2	36.2	36.2	39.4	30.4	34.0	34.0	33.9	33.9	36.5	29.0
1200	75	36.2	31.6	40.4	23.7	44.8	15.7	33.8	30.2	37.8	22.4	42.2	14.5	31.4	28.8	35.2	21.0	39.4	13.2	29.0	27.4	32.5	19.6	36.4	11.9
	80	37.1	37.1	40.6	30.2	45.0	22.3	35.0	35.0	38.0	28.8	42.3	21.0	32.9	32.9	35.4	27.5	39.6	19.7	30.7	30.7	32.7	26.1	36.6	18.3
	85	39.5	39.5	41.0	36.7	45.1	28.7	37.4	37.4	38.4	35.4	42.5	27.4	35.2	35.2	35.9	34.0	39.8	26.1	33.0	33.0	33.3	32.7	36.8	24.7
	90	42.0	42.0	42.0	42.0	45.4	35.1	39.8	39.8	39.8	39.8	42.8	33.8	37.5	37.5	37.5	37.5	40.1	32.5	35.2	35.2	35.2	35.2	37.1	31.1
1320	75	36.8	33.4	40.9	24.8	45.3	16.1	34.4	32.1	38.3	23.4	42.6	14.8	32.0	30.7	35.6	22.0	39.9	13.5	29.6	29.3	32.9	20.6	36.9	12.2
	80	38.3	38.3	41.2	31.9	45.5	23.1	36.1	36.1	38.6	30.5	42.8	21.9	33.9	33.9	35.9	29.1	40.0	20.6	31.7	31.7	33.2	27.7	37.1	19.2
	85	40.8	40.8	41.7	39.0	45.7	30.2	38.6	38.6	39.2	37.7	43.0	28.9	36.3	36.3	36.6	36.3	40.2	27.5	34.0	34.0	34.0	34.0	37.3	26.2
	90	43.3	43.3	43.3	43.3	46.0	37.1	41.1	41.1	41.1	41.1	43.3	35.9	38.8	38.8	38.8	38.8	40.6	34.6	36.3	36.3	36.3	36.3	37.7	33.2
1440	75	37.4	35.2	41.4	25.8	45.8	16.4	35.0	33.9	38.7	24.4	43.0	15.1	32.6	32.5	36.0	23.0	40.2	13.8	30.1	30.1	33.2	21.6	37.2	12.5
	80	39.3	39.3	41.7	33.5	46.0	24.0	37.1	37.1	39.1	32.1	43.2	22.7	34.8	34.8	36.4	30.7	40.4	21.4	32.5	32.5	33.6	29.3	37.4	20.0
	85	41.9	41.9	42.4	41.3	46.1	31.6	39.7	39.7	39.6	39.6	43.4	30.3	37.3	37.3	37.3	37.3	40.6	29.0	34.9	34.9	34.9	34.9	37.7	27.6
	90	44.4	44.4	44.4	44.4	46.5	39.2	42.2	42.2	42.2	42.2	43.8	37.9	39.8	39.8	39.8	39.8	41.1	36.6	37.3	37.3	37.3	37.3	38.2	35.3

**Notes:**

1. All capacities shown are gross and have not considered indoor fan heat. To obtain **NET** cooling capacity subtract indoor fan heat. For indoor fan heat formula, refer to appropriate airflow table notes.

2. MBH = Total Gross Capacity

3. SHC = Sensible Heat Capacity

**\*Unit applications below 960 CFM**

- Electric heaters restricted on applications below 960 CFM.
- Dehumidification (Hot Gas Reheat) or TXV with Froststat and Crankcase Heaters are required on applications below 960 CFM.



# Performance Data

# (4 Ton) High Efficiency

**Table PD-12 — Gross Cooling Capacities (MBH) 4 Ton THC048A1, A3, A4, AW- Standard Refrigeration Option**

CFM Airflow		Ambient Temperature (F)																																			
		85						95						105						115																	
		Enter. Dry Bulb (F)		61		67		73		61		67		73		61		67		73		61		67		73											
		MBH	SHC	MBH	SHC	MBH	SHC	MBH	SHC	MBH	SHC	MBH	SHC	MBH	SHC	MBH	SHC	MBH	SHC	MBH	SHC	MBH	SHC	MBH	SHC	MBH	SHC										
1440	75	45.3	39.9	51.4	30.3	54.9	19.9	41.1	37.7	48.4	28.8	53.1	18.7	37.1	35.6	43.9	26.7	51.0	17.4	33.2	33.2	39.3	24.6	47.8	16.0	40.3	40.3	44.3	34.9	51.3	25.6	36.9	36.9	39.8	32.8	47.9	24.1
	80	47.1	47.1	52.0	38.4	55.5	28.1	43.8	43.8	48.7	36.9	54.6	27.2	40.3	40.3	44.3	34.9	51.3	25.6	36.9	36.9	39.8	32.8	47.9	24.1	44.3	44.3	45.3	43.3	51.6	33.6	40.9	40.9	40.9	40.9	48.1	32.2
	85	50.5	50.5	52.5	46.3	56.2	34.5	47.8	47.8	49.4	45.2	54.9	34.9	44.3	44.3	45.3	43.3	51.6	33.6	40.9	40.9	40.9	40.9	48.1	32.2	44.3	44.3	45.3	43.3	51.6	33.6	40.9	40.9	40.9	40.9	48.1	32.2
	90	53.1	53.1	53.5	53.5	56.9	41.4	51.2	51.2	51.2	51.2	54.6	41.4	48.4	48.4	48.4	48.4	52.0	41.2	45.0	45.0	45.0	45.0	48.6	40.2	48.4	48.4	48.4	48.4	52.0	41.2	45.0	45.0	45.0	45.0	48.6	40.2
1600	75	46.7	42.7	52.7	31.9	55.2	20.2	42.4	40.5	49.4	30.3	54.4	19.3	38.2	38.2	45.0	28.4	51.6	17.8	34.7	34.7	40.2	26.2	48.6	16.4	40.3	42.3	45.6	37.5	51.9	26.9	38.7	38.7	40.9	35.3	48.7	25.4
	80	49.2	49.2	52.8	40.4	55.9	28.2	46.0	46.0	49.8	39.4	55.2	28.4	42.3	42.3	45.6	37.5	51.9	26.9	38.7	38.7	40.9	35.3	48.7	25.4	46.7	46.7	47.0	46.8	52.2	35.2	43.0	43.0	42.9	42.9	49.0	34.3
	85	52.1	52.1	53.5	48.8	56.6	35.4	49.9	49.9	50.6	48.3	55.7	36.8	46.7	46.7	47.0	46.8	52.2	35.2	43.0	43.0	42.9	42.9	49.0	34.3	46.7	46.7	47.0	46.8	52.2	35.2	43.0	43.0	42.9	42.9	49.0	34.3
	90	54.5	54.5	54.8	54.8	57.4	42.7	52.8	52.8	52.8	52.8	55.2	42.9	50.5	50.5	50.5	50.5	52.9	43.5	47.4	47.4	47.4	47.4	49.6	43.0	50.5	50.5	50.5	50.5	52.9	43.5	47.4	47.4	47.4	47.4	49.6	43.0
1760	75	47.8	45.4	53.2	33.4	55.5	20.6	43.7	43.3	50.1	31.8	54.7	19.6	39.7	39.7	46.0	30.0	51.9	18.2	36.1	36.1	41.0	27.7	49.1	16.8	44.1	44.1	46.7	39.9	52.4	28.1	40.4	40.4	41.9	37.8	49.3	26.7
	80	50.6	50.6	53.4	42.1	56.2	28.7	47.8	47.8	50.5	41.5	55.7	29.4	44.1	44.1	46.7	39.9	52.4	28.1	40.4	40.4	41.9	37.8	49.3	26.7	48.6	48.6	48.6	48.6	52.8	36.7	44.9	44.9	44.9	44.9	49.7	36.3
	85	53.1	53.1	54.2	50.9	57.0	36.2	51.4	51.4	51.6	51.0	56.2	38.0	48.6	48.6	48.6	48.6	52.8	36.7	44.9	44.9	44.9	44.9	49.7	36.3	48.6	48.6	48.6	48.6	52.8	36.7	44.9	44.9	44.9	44.9	49.7	36.3
	90	55.1	55.1	55.7	55.7	57.7	43.8	53.9	53.9	53.9	53.9	55.6	44.3	51.9	51.9	51.9	51.9	53.5	45.6	49.2	49.2	49.2	49.2	50.5	45.7	51.9	51.9	51.9	51.9	53.5	45.6	49.2	49.2	49.2	49.2	50.5	45.7
1920	75	48.8	48.1	53.6	34.4	55.7	20.9	45.0	45.0	50.6	33.2	55.0	20.0	41.0	41.0	46.8	31.5	52.3	18.5	37.3	37.3	41.7	29.3	49.6	17.2	45.8	45.8	47.6	42.3	52.8	28.9	41.8	41.8	42.8	40.2	49.8	27.9
	80	51.7	51.7	53.9	43.5	56.4	31.7	49.3	49.3	51.2	43.5	56.0	30.1	45.8	45.8	47.6	42.3	52.8	28.9	41.8	41.8	42.8	40.2	49.8	27.9	50.0	50.0	50.0	50.0	53.2	38.1	46.6	46.6	46.6	46.6	50.3	38.1
	85	53.9	53.9	54.8	52.7	57.2	36.9	52.4	52.4	52.4	52.4	56.5	39.1	50.0	50.0	50.0	50.0	53.2	38.1	46.6	46.6	46.6	46.6	50.3	38.1	50.0	50.0	50.0	50.0	53.2	38.1	46.6	46.6	46.6	46.6	50.3	38.1
	90	55.7	55.7	56.3	56.3	58.0	44.8	54.7	54.7	54.7	54.7	56.0	45.6	53.0	53.0	53.0	53.0	54.0	47.4	50.5	50.5	50.5	50.5	51.2	48.1	53.0	53.0	53.0	53.0	54.0	47.4	50.5	50.5	50.5	50.5	51.2	48.1

**Notes:**

- All capacities shown are gross and have not considered indoor fan heat. To obtain **NET** cooling capacity subtract indoor fan heat. For indoor fan heat formula, refer to appropriate airflow table notes.
- MBH = Total Gross Capacity
- SHC = Sensible Heat Capacity



# Performance Data

## (4 Ton) High Efficiency

**Table PD-13 – Gross Cooling Capacities (MBH) 4 Ton THC048A1, A3, A4, AW – Dehumidification (Hot Gas Reheat) or TXV Option**

CFM	Enter. Dry Bulb (F)	Ambient Temperature (F)																							
		85				95				105				115											
		61		67		73		61		67		73		61		67		73							
Airflow		MBH	SHC	MBH	SHC	MBH	SHC	MBH	SHC	MBH	SHC	MBH	SHC	MBH	SHC	MBH	SHC	MBH	SHC	MBH	SHC	MBH	SHC		
800*	75	40.4	29.1	45.7	23.7	51.3	18.2	38.2	27.7	43.3	22.4	48.8	16.9	35.8	26.3	40.6	20.9	45.9	15.4	33.3	24.8	38.0	19.5	43.1	14.0
	80	40.5	33.8	45.8	28.4	51.5	22.8	38.3	32.4	43.4	27.0	48.9	21.5	35.9	31.0	40.8	25.5	46.0	20.0	33.4	29.5	38.1	24.1	43.2	18.6
	85	40.8	38.5	45.9	33.1	51.6	27.5	38.5	37.1	43.5	31.7	49.0	26.1	36.2	35.7	40.8	30.2	46.1	24.6	33.9	33.9	38.2	28.7	43.3	23.2
	90	42.0	42.0	46.1	37.7	51.7	32.1	40.1	40.1	43.7	36.3	49.1	30.7	38.1	38.1	41.0	34.8	46.2	29.2	36.1	36.1	38.4	33.3	43.4	27.8
1040*	75	43.3	33.5	48.8	26.4	54.6	19.2	40.8	32.1	46.2	25.0	51.8	17.8	38.2	30.6	43.2	23.5	48.6	16.3	35.5	29.1	40.4	22.0	45.5	14.9
	80	43.6	39.6	48.9	32.4	54.7	25.1	41.1	38.2	46.3	31.0	51.9	23.8	38.6	36.7	43.3	29.5	48.7	22.3	36.0	35.2	40.5	28.0	45.7	20.8
	85	44.7	44.7	49.1	38.4	54.9	31.1	42.6	42.6	46.5	37.0	52.1	29.7	40.4	40.4	43.6	35.4	48.8	28.2	38.2	38.2	40.7	33.9	45.8	26.7
	90	47.3	47.3	49.4	44.4	55.0	37.0	45.2	45.2	46.8	42.9	52.2	35.6	43.0	43.0	44.0	41.4	49.0	34.0	40.7	40.7	41.2	39.9	46.0	32.6
1280	75	45.3	37.7	50.8	28.9	56.7	20.0	42.7	36.2	48.0	27.5	53.8	18.6	40.0	34.7	44.9	25.9	50.3	17.0	37.2	33.1	41.9	24.4	47.1	15.6
	80	46.0	45.1	51.0	36.2	56.9	27.3	43.4	43.4	48.2	34.7	53.9	25.9	41.1	41.1	45.1	33.1	50.5	24.3	38.7	38.7	42.1	31.6	47.3	22.9
	85	48.5	48.5	51.3	43.5	57.0	34.5	46.2	46.2	48.6	42.0	54.1	33.1	43.9	43.9	45.5	40.4	50.6	31.5	41.4	41.4	42.6	38.9	47.5	30.0
	90	51.4	51.4	52.1	50.8	57.3	41.7	49.1	49.1	49.5	49.4	54.3	40.3	46.7	46.7	46.7	46.7	50.9	38.7	44.2	44.2	44.2	44.2	47.7	37.2
1440	75	46.3	40.3	51.5	30.3	57.4	20.3	43.7	38.8	48.7	28.9	54.3	18.9	41.0	37.3	45.7	27.4	51.2	17.5	38.1	35.8	42.7	25.9	47.9	16.0
	80	47.6	47.6	51.8	38.5	57.6	28.5	45.2	45.2	49.0	37.0	54.5	27.1	42.8	42.8	46.0	35.5	51.3	25.6	40.3	40.3	43.0	34.0	48.1	24.2
	85	50.6	50.6	52.3	46.6	57.7	36.5	48.2	48.2	49.5	45.2	54.7	35.1	45.7	45.7	46.6	43.7	51.5	33.7	43.2	43.2	43.7	42.2	48.3	32.2
	90	53.6	53.6	53.6	53.6	58.1	44.6	51.2	51.2	51.2	51.2	55.0	43.2	48.7	48.7	48.7	48.7	51.9	41.7	46.1	46.1	46.1	46.1	48.7	40.2
1600	75	47.3	42.9	52.4	31.8	58.2	20.7	44.6	41.4	49.4	30.4	55.1	19.3	41.8	39.9	46.4	28.9	51.9	17.9	39.0	38.4	43.3	27.4	48.6	16.4
	80	49.2	49.2	52.7	40.9	58.4	29.8	46.8	46.8	49.8	39.4	55.3	28.4	44.3	44.3	46.8	37.9	52.0	26.9	41.7	41.7	43.7	36.4	48.7	25.4
	85	52.4	52.4	53.4	49.9	58.6	38.7	49.9	49.9	50.6	48.5	55.5	37.3	47.4	47.4	47.7	47.0	52.3	35.8	44.7	44.7	44.7	44.7	49.0	34.3
	90	55.6	55.6	55.6	55.6	59.1	47.6	53.1	53.1	53.1	53.1	56.0	46.2	50.4	50.4	50.4	50.4	52.8	44.7	47.7	47.7	47.7	47.7	49.5	43.2
1760	75	48.2	45.5	53.0	33.3	59.0	21.2	45.5	44.0	50.1	31.8	55.8	19.8	42.7	42.5	47.0	30.3	52.5	18.3	39.9	39.9	43.8	28.8	49.1	16.8
	80	50.7	50.7	53.5	43.2	59.1	31.1	48.2	48.2	50.5	41.7	55.9	29.6	45.6	45.6	47.5	40.2	52.6	28.2	42.9	42.9	44.4	38.7	49.3	26.7
	85	54.0	54.0	54.4	53.1	59.4	40.8	51.4	51.4	51.4	51.4	56.2	39.4	48.8	48.8	48.8	48.8	52.9	37.9	46.0	46.0	46.0	46.0	49.6	36.4
	90	57.3	57.3	57.3	57.3	59.9	50.5	54.7	54.7	54.7	54.7	56.8	49.1	52.0	52.0	52.0	52.0	53.6	47.6	49.2	49.2	49.2	49.2	50.3	46.1
1920	75	49.0	48.1	53.6	34.7	59.6	21.6	46.1	46.1	50.6	33.3	56.3	20.2	43.6	43.6	47.5	31.8	53.0	18.7	40.9	40.9	44.3	30.2	49.5	17.2
	80	52.0	52.0	54.2	45.4	59.7	32.3	49.4	49.4	51.2	44.0	56.5	30.9	46.8	46.8	48.1	42.5	53.2	29.4	44.0	44.0	45.0	41.0	49.7	27.9
	85	55.4	55.4	55.3	55.3	60.0	42.9	52.7	52.7	52.7	52.7	56.9	41.5	50.0	50.0	50.0	50.0	53.5	40.0	47.2	47.2	47.2	47.2	50.1	38.5
	90	58.8	58.8	58.8	58.8	60.7	53.4	56.1	56.1	56.1	56.1	57.6	52.0	53.3	53.3	53.3	53.3	54.4	50.6	50.4	50.4	50.4	51.0	49.1	

**Notes:**

1. All capacities shown are gross and have not considered indoor fan heat. To obtain **NET** cooling capacity subtract indoor fan heat. For indoor fan heat formula, refer to appropriate airflow table notes.

2. MBH = Total Gross Capacity

3. SHC = Sensible Heat Capacity

**\*Unit applications below 1280 CFM**

- Electric heaters restricted on applications below 1280 CFM.
- Dehumidification (Hot Gas Reheat) or TXV with Froststat and Crankcase Heaters are required on applications below 1280 CFM.



# Performance Data (5 Ton) High Efficiency

**Table PD-14 – Gross Cooling Capacities (MBH) 5 Ton Single Phase THC060A1– Standard Refrigeration Option**

		Ambient Temperature (F)																							
		85				95				105				115											
		Enter. Dry Bulb (F)		61		67		73		Enter. Wet Bulb (F)		61		67		73									
CFM	Airflow	MBH	SHC	MBH	SHC	MBH	SHC	MBH	SHC	MBH	SHC	MBH	SHC	MBH	SHC	MBH	SHC								
1800	75	56.2	48.2	64.3	37.8	68.4	24.8	51.4	45.6	60.5	35.2	66.7	23.5	46.8	43.2	55.3	32.8	63.9	21.9	42.2	40.8	50.0	31.0	59.9	20.1
	80	57.6	57.6	64.6	46.6	69.3	34.7	53.7	53.7	60.7	44.8	67.3	33.1	49.8	49.8	55.5	42.3	64.2	31.5	45.9	45.9	50.5	39.9	60.1	29.6
	85	62.2	62.2	65.2	55.8	70.1	42.6	58.4	58.4	61.4	54.5	68.0	42.2	54.5	54.5	56.5	52.0	64.6	40.9	50.6	50.6	51.6	49.7	60.3	39.0
	90	65.8	65.8	66.3	64.9	70.9	50.8	63.0	63.0	63.0	63.0	68.2	52.0	59.3	59.3	59.2	59.2	65.0	49.9	55.3	55.3	55.3	55.3	60.7	48.5
2000	75	57.8	51.4	65.2	38.8	69.6	25.4	52.9	48.8	61.8	37.0	67.3	23.9	48.2	46.3	56.5	34.6	64.6	22.4	43.3	43.3	51.2	32.1	60.9	20.7
	80	60.3	60.3	65.6	48.8	69.8	35.2	56.2	56.2	62.1	47.6	68.0	34.6	52.1	52.1	56.9	45.1	65.0	32.9	48.1	48.1	51.7	42.7	61.2	31.1
	85	64.4	64.4	66.3	58.7	70.7	43.8	61.2	61.2	63.0	58.1	68.7	43.9	57.1	57.1	58.2	56.0	65.4	42.8	53.0	53.0	53.0	53.0	61.4	41.5
	90	67.6	67.6	67.6	67.6	71.6	52.5	65.2	65.2	65.2	65.2	69.5	53.3	62.0	62.0	62.0	62.0	66.0	52.6	58.0	58.0	58.0	58.0	62.0	51.8
2200	75	59.4	54.5	65.7	40.1	69.3	25.6	54.3	51.9	62.7	38.7	67.7	24.3	49.6	49.4	57.6	36.3	65.1	22.8	45.0	45.0	52.2	33.8	61.6	21.1
	80	62.4	62.4	66.3	50.7	70.3	35.8	58.4	58.4	63.1	50.1	68.5	35.4	54.2	54.2	58.2	47.9	65.7	34.2	50.0	50.0	52.9	45.4	61.9	32.5
	85	66.0	66.0	67.3	61.2	71.2	44.8	63.3	63.3	64.2	61.3	69.4	45.3	59.4	59.4	59.9	59.8	66.1	44.6	55.2	55.2	55.2	55.2	62.2	43.7
	90	68.9	68.9	68.9	68.9	72.2	54.0	66.9	66.9	66.9	66.9	70.2	55.4	64.0	64.0	64.0	64.0	66.8	55.1	60.4	60.4	60.4	60.4	63.0	54.6
2400	75	60.6	57.4	66.1	41.5	69.7	26.0	55.6	54.9	63.4	40.3	68.1	24.7	50.8	50.8	58.5	38.0	65.5	23.2	46.5	46.5	53.0	35.5	62.1	21.5
	80	64.0	64.0	67.0	52.5	70.6	38.5	60.4	60.4	63.9	52.4	69.0	36.1	56.1	56.1	59.2	50.5	66.1	35.8	51.8	51.8	54.0	48.1	62.5	33.8
	85	67.2	67.2	68.0	63.5	71.5	50.9	64.9	64.9	65.3	64.2	69.9	46.6	61.4	61.4	61.4	61.4	67.0	46.8	57.2	57.2	57.2	57.2	62.9	45.6
	90	69.8	69.8	69.8	69.8	72.6	55.3	68.1	68.1	68.1	68.1	70.8	57.1	65.5	65.5	65.5	65.5	67.5	57.3	62.2	62.2	62.2	62.2	63.9	57.2

Notes:

1. All capacities shown are gross and have not considered indoor fan heat. To obtain **NET** cooling capacity subtract indoor fan heat. For indoor fan heat formula, refer to appropriate airflow table notes.
2. MBH = Total Gross Capacity
3. SHC = Sensible Heat Capacity

**Table PD-15 – Gross Cooling Capacities (MBH) 5Ton Three Phase THC060A3, A4, AW– Standard Refrigeration Option**

		Ambient Temperature (F)																							
		85				95				105				115											
		Enter. Dry Bulb (F)		61		67		73		Enter. Wet Bulb (F)		61		67		73									
CFM	Airflow	MBH	SHC	MBH	SHC	MBH	SHC	MBH	SHC	MBH	SHC	MBH	SHC	MBH	SHC	MBH	SHC								
1800	75	56.6	49.0	64.4	37.5	67.7	24.7	52.0	46.8	60.9	35.7	66.2	23.3	47.0	44.2	55.9	33.3	63.6	21.8	42.3	41.7	50.0	30.7	59.8	20.0
	80	58.5	58.5	64.6	47.0	68.6	34.7	54.7	54.7	61.2	45.5	66.8	33.3	50.6	50.6	56.3	43.2	64.1	31.7	46.4	46.4	50.5	40.5	60.0	29.8
	85	62.9	62.9	65.3	56.4	69.4	42.2	59.6	59.6	61.9	55.5	67.7	42.3	55.6	55.6	57.3	53.2	64.3	41.1	51.2	51.2	51.9	50.7	60.3	39.5
	90	66.2	66.2	66.4	65.6	70.3	50.3	63.7	63.7	63.7	63.7	68.4	51.2	60.3	60.3	60.3	60.3	64.9	50.3	56.4	56.4	56.3	56.3	60.8	49.1
2000	75	58.3	52.5	65.0	39.1	68.1	25.1	53.6	50.0	62.0	37.6	66.6	23.8	48.6	47.7	57.2	35.4	64.2	22.3	43.8	43.8	51.2	32.7	60.6	20.5
	80	61.1	61.1	65.6	49.2	69.0	34.6	57.3	57.3	62.4	48.4	67.5	34.8	53.2	53.2	57.8	46.2	64.7	33.2	48.7	48.7	52.0	43.6	60.9	31.4
	85	64.9	64.9	66.4	59.2	69.9	43.1	62.1	62.1	63.4	59.1	67.8	43.0	58.4	58.4	59.2	57.5	64.9	43.9	54.0	54.0	54.0	54.0	61.2	42.0
	90	67.7	67.7	67.7	67.7	70.8	51.7	65.7	65.7	65.7	65.7	68.6	52.2	62.8	62.8	62.8	62.8	65.9	52.9	59.0	59.0	59.0	59.0	61.9	52.3
2200	75	59.9	55.8	65.8	40.7	68.4	25.5	55.2	53.4	62.9	39.5	67.0	24.2	50.0	50.0	58.3	37.3	64.6	22.7	45.6	45.6	52.4	34.7	61.2	21.0
	80	63.1	63.1	66.3	51.0	69.3	35.2	59.7	59.7	63.5	51.0	67.9	35.1	55.5	55.5	59.0	49.2	65.4	34.5	50.8	50.8	53.4	46.6	61.6	32.9
	85	66.4	66.4	67.2	61.6	70.2	43.9	64.0	64.0	64.6	62.4	68.8	44.9	60.6	60.6	60.6	60.6	66.0	45.1	56.4	56.4	56.4	56.4	62.0	44.2
	90	68.7	68.7	68.7	68.7	71.2	52.8	67.1	67.1	67.1	67.1	69.7	54.9	64.5	64.5	64.5	64.5	66.9	55.8	61.0	61.0	61.0	61.0	62.9	55.3
2400	75	61.2	59.0	66.2	41.7	68.6	25.9	56.3	56.3	63.6	41.3	67.3	24.6	51.9	51.9	59.2	39.0	65.0	23.1	47.2	47.2	53.4	36.6	61.7	21.4
	80	64.5	64.5	67.0	53.1	69.6	35.6	61.6	61.6	64.2	53.3	68.2	35.7	57.5	57.5	60.1	52.1	65.8	35.5	52.8	52.8	54.7	49.6	62.1	34.3
	85	67.3	67.3	68.1	64.0	70.5	44.7	65.4	65.4	65.6	65.2	69.1	46.0	62.4	62.4	62.3	62.3	66.6	46.8	58.4	58.4	58.4	58.4	62.6	46.2
	90	69.4	69.4	69.5	69.5	71.5	53.9	68.1	68.1	68.1	70.1	56.3	65.7	65.7	65.7	65.7	67.6	58.0	62.5	62.5	62.5	62.5	63.7	57.9	

Notes:

1. All capacities shown are gross and have not considered indoor fan heat. To obtain **NET** cooling capacity subtract indoor fan heat. For indoor fan heat formula, refer to appropriate airflow table notes.
2. MBH = Total Gross Capacity
3. SHC = Sensible Heat Capacity



# Performance Data

## (5 Ton) High Efficiency

**Table PD-16 – Gross Cooling Capacities (MBH) 5Ton THC060A3, A4, AW – Dehumidification (Hot Gas Reheat) or TXV Option**

CFM Airflow		Ambient Temperature (F)																							
		85						95						105						115					
		Enter. Dry Bulb (F)		61		67		73		61		67		73		61		67		73		61		67	
		MBH	SHC	MBH	SHC	MBH	SHC	MBH	SHC	MBH	SHC	MBH	SHC	MBH	SHC	MBH	SHC	MBH	SHC	MBH	SHC	MBH	SHC	MBH	SHC
1000*	75	50.7	36.2	57.0	29.4	63.7	22.6	48.1	34.6	54.2	27.9	60.7	21.0	45.5	32.9	51.3	26.2	57.5	19.4	42.7	31.2	48.2	24.5	54.1	17.7
	80	50.8	41.8	57.1	35.1	63.8	28.2	48.3	40.2	54.4	33.5	60.8	26.6	45.6	38.6	51.5	31.9	57.6	25.0	42.9	36.8	48.4	30.1	54.2	23.3
	85	51.0	47.5	57.2	40.7	64.0	33.8	48.6	45.9	54.5	39.1	61.0	32.2	46.0	44.2	51.6	37.4	57.8	30.6	43.3	42.5	48.5	35.7	54.4	28.8
	90	52.2	52.2	57.4	46.3	64.1	39.4	50.1	50.1	54.6	44.7	61.1	37.8	47.8	47.8	51.7	43.0	57.9	36.1	45.5	45.5	48.7	41.3	54.5	34.4
1300*	75	54.3	41.5	60.7	32.7	67.6	23.8	51.5	39.9	57.7	31.0	64.3	22.1	48.6	38.1	54.5	29.3	60.8	20.4	45.5	36.4	51.1	27.5	57.0	18.7
	80	54.6	48.8	60.9	40.0	67.8	31.0	51.9	47.1	57.9	38.3	64.5	29.3	49.0	45.4	54.7	36.6	60.9	27.6	46.0	43.6	51.3	34.8	57.2	25.9
	85	55.6	55.6	61.1	47.2	67.9	38.2	53.2	53.2	58.1	45.5	64.6	36.5	50.7	50.7	54.9	43.7	61.1	34.8	48.1	48.1	51.5	41.9	57.4	33.0
	90	58.8	58.8	61.5	54.4	68.1	45.3	56.3	56.3	58.5	52.7	64.8	43.6	53.7	53.7	55.3	50.9	61.3	41.9	51.0	51.0	52.0	49.1	57.5	40.1
1600	75	56.8	46.5	63.2	35.6	70.2	24.7	53.9	44.9	60.0	33.9	66.6	23.0	50.8	43.1	56.6	32.2	62.9	21.3	47.5	41.3	53.0	30.4	58.9	19.5
	80	57.6	55.5	63.4	44.5	70.3	33.5	54.7	53.8	60.2	42.7	66.8	31.8	51.6	51.6	56.8	41.0	63.0	30.1	48.8	48.8	53.2	39.1	59.1	28.3
	85	60.3	60.3	63.8	53.2	70.5	42.2	57.7	57.7	60.6	51.5	67.0	40.5	54.9	54.9	57.3	49.7	63.2	38.8	52.0	52.0	53.7	47.9	59.3	36.9
	90	63.8	63.8	64.7	62.1	70.8	50.9	61.1	61.1	61.6	60.4	67.3	49.2	58.2	58.2	58.2	58.2	63.5	47.4	55.1	55.1	55.1	55.1	59.6	45.6
1800	75	58.1	49.6	64.5	37.5	71.4	25.2	55.1	48.2	61.1	35.8	67.8	23.5	51.9	46.3	57.6	34.0	63.9	21.8	48.6	44.5	53.9	32.2	59.8	20.0
	80	59.3	59.3	64.7	47.4	71.6	35.1	56.6	56.6	61.4	45.6	67.9	33.4	53.8	53.8	57.9	43.8	64.1	31.6	50.8	50.8	54.2	42.0	60.0	29.8
	85	62.9	62.9	65.3	57.2	71.8	44.9	60.1	60.1	62.0	55.4	68.2	43.1	57.2	57.2	58.6	53.6	64.3	41.3	54.1	54.1	55.0	51.8	60.2	39.5
	90	66.5	66.5	66.5	66.5	72.2	54.6	63.7	63.7	63.7	63.7	68.5	52.9	60.6	60.6	60.6	60.6	64.7	51.0	57.4	57.4	57.4	57.4	60.7	49.1
2000	75	59.3	51.6	65.9	38.8	73.0	25.8	55.9	49.6	62.1	36.9	69.0	23.9	52.3	47.6	58.3	34.8	64.9	22.0	48.7	45.5	54.4	32.8	60.8	20.1
	80	60.9	60.9	66.1	49.3	73.2	36.4	57.9	57.9	3.0	47.3	69.2	34.5	54.7	54.7	58.6	45.3	65.2	32.5	51.4	51.4	54.7	43.2	61.0	30.5
	85	64.8	64.8	66.9	59.8	73.5	46.9	61.6	61.6	63.2	57.8	69.5	44.9	58.4	58.4	59.5	55.8	65.4	42.9	55.0	55.0	55.7	53.8	61.3	40.9
	90	68.6	68.6	68.6	68.6	73.8	57.1	65.4	65.4	65.3	65.3	69.9	55.1	62.1	62.1	62.0	62.0	65.9	53.2	58.7	58.7	58.7	58.7	61.8	51.2
2200	75	60.4	54.5	66.7	40.5	73.8	26.4	56.9	52.4	62.9	38.5	69.8	24.5	53.3	50.4	59.0	36.5	65.7	22.5	49.6	48.3	55.1	34.4	61.5	20.5
	80	62.7	62.7	67.1	51.8	74.1	37.8	59.5	59.5	63.3	49.8	70.0	35.9	56.3	56.3	59.4	47.8	65.9	33.9	52.9	52.9	55.5	45.8	61.7	31.9
	85	66.7	66.7	68.0	63.3	74.4	49.2	63.4	63.4	64.3	61.3	70.3	47.2	60.1	60.1	60.6	59.3	66.2	45.2	56.7	56.7	56.6	56.6	62.0	43.2
	90	70.6	70.6	70.6	70.6	74.9	60.3	67.3	67.3	67.3	67.3	70.8	58.3	63.9	63.9	63.9	63.9	66.8	56.4	60.4	60.4	60.4	60.4	62.7	54.4
2400	75	61.3	57.2	67.5	42.1	74.6	26.9	57.8	55.2	63.6	40.1	70.5	24.9	54.2	53.2	59.7	38.0	66.3	22.9	50.4	50.4	55.7	36.0	62.1	21.0
	80	64.3	64.3	67.9	54.3	74.9	39.2	61.0	61.0	64.1	52.3	70.7	37.2	57.7	57.7	60.2	50.3	66.6	35.2	54.2	54.2	56.2	48.2	62.3	33.2
	85	68.4	68.4	69.1	66.7	75.1	51.4	65.0	65.0	65.4	64.8	71.0	49.4	61.6	61.6	61.6	61.6	66.8	47.4	58.1	58.1	58.1	58.1	62.6	45.4
	90	72.4	72.4	72.4	72.4	75.8	63.5	69.0	69.0	69.0	69.0	71.7	61.5	65.5	65.5	65.5	65.5	67.6	59.5	61.9	61.9	61.9	61.9	63.5	57.5

**Notes:**

- All capacities shown are gross and have not considered indoor fan heat. To obtain **NET** cooling capacity subtract indoor fan heat. For indoor fan heat formula, refer to appropriate airflow table notes.
  - MBH = Total Gross Capacity
  - SHC = Sensible Heat Capacity
- \*Unit applications below 1600 CFM**
- Electric heaters restricted on applications below 1600 CFM.
  - Dehumidification (Hot Gas Reheat) or TXV with Froststat and Crankcase Heaters are required on applications below 1600 CFM.



# Performance Data

# (6 Ton) High Efficiency

**Table PD-17 – Gross Cooling Capacities (MBH) 6Ton Three Phase THC072A3, A4, AW– Standard Refrigeration Option**

		Ambient Temperature (F)																							
		85						95						105						115					
CFM Airflow	Enter. Dry Bulb (F)	Entering Wet Bulb (F)																							
		61		67		73		61		67		73		61		67		73		61		67		73	
		MBH	SHC	MBH	SHC	MBH	SHC	MBH	SHC	MBH	SHC	MBH	SHC	MBH	SHC	MBH	SHC	MBH	SHC	MBH	SHC	MBH	SHC	MBH	SHC
2160	75	67.3	56.6	73.6	42.5	74.5	27.6	61.6	53.5	71.8	41.9	75.1	26.6	55.8	50.4	66.8	38.7	74.1	25.3	49.8	47.2	59.9	36.3	71.3	23.5
	80	68.7	68.2	73.8	51.7	75.4	37.0	63.6	63.6	72.0	52.1	76.0	38.1	58.9	58.9	66.9	49.7	74.7	36.4	54.1	54.1	60.2	46.5	71.5	34.5
	85	72.2	72.2	74.5	61.4	76.2	44.5	69.2	69.2	72.5	62.8	76.8	46.1	64.6	64.6	67.8	60.9	75.0	46.2	59.5	59.5	61.3	57.7	71.7	45.4
2400	75	74.7	74.7	75.3	70.6	77.0	51.9	73.4	73.4	73.7	73.2	77.7	55.1	70.1	70.1	70.1	70.1	75.6	56.1	65.4	65.4	65.4	65.4	72.1	55.8
	80	69.0	60.1	74.0	43.3	74.5	27.9	63.5	57.2	72.7	43.1	75.2	27.0	57.5	54.0	68.4	40.9	74.5	25.7	51.8	51.0	61.5	37.6	72.0	24.0
	85	70.7	70.7	74.3	52.9	75.4	37.2	66.8	66.8	73.0	54.6	76.2	37.8	61.9	61.9	68.7	53.0	75.1	37.4	56.7	56.7	61.9	49.8	72.4	36.1
2640	75	73.8	73.8	75.0	63.0	76.2	44.9	71.9	71.9	73.8	66.0	77.1	47.0	67.9	67.9	69.7	65.4	75.5	47.5	62.7	62.7	63.6	62.4	72.6	47.7
	80	75.6	75.6	75.9	72.4	77.0	52.5	75.2	75.2	75.1	75.1	78.0	56.3	72.8	72.8	72.7	72.7	76.4	58.2	68.8	68.8	68.8	68.8	73.2	59.0
	85	70.3	63.2	74.2	43.9	74.6	28.3	65.2	60.8	73.2	44.5	75.4	27.4	59.2	57.7	69.6	42.9	74.7	26.2	53.2	53.2	62.9	39.8	72.5	24.6
2880	75	72.3	72.3	74.5	53.9	75.4	37.4	69.5	69.5	73.8	56.7	76.3	38.2	64.6	64.6	70.0	56.1	75.6	38.5	59.2	59.2	63.5	53.0	73.0	37.7
	80	74.7	74.7	75.3	64.3	76.2	45.2	73.7	73.7	74.7	68.7	77.3	47.6	70.5	70.5	71.3	69.3	76.1	48.9	65.6	65.6	65.6	65.6	73.4	49.7
	85	76.1	76.1	76.2	73.6	76.9	53.0	76.2	76.2	76.2	76.2	78.1	57.2	74.5	74.5	74.5	74.5	76.9	59.9	71.2	71.2	71.2	71.2	74.1	61.7
2880	75	71.3	65.8	74.3	44.4	74.6	28.7	66.8	64.4	73.7	45.6	75.5	27.8	60.5	60.5	70.6	44.8	74.9	26.6	55.1	55.1	64.1	41.8	72.9	25.0
	80	73.3	73.3	74.7	54.8	75.4	37.6	71.4	71.4	74.4	58.5	76.4	38.5	67.0	67.0	71.0	58.9	75.9	39.1	61.4	61.4	64.9	56.2	73.3	38.6
	85	75.1	75.1	75.5	65.3	76.2	45.6	74.8	74.8	75.4	70.8	77.4	48.2	72.4	72.4	72.4	72.4	76.4	49.9	68.2	68.2	68.1	68.1	74.0	51.5
	90	76.3	76.3	76.3	74.5	76.9	53.5	76.9	76.9	76.9	76.9	78.2	58.0	75.7	75.7	75.7	75.7	77.2	61.3	72.9	72.9	72.9	72.9	74.8	64.1

Notes:

1. All capacities shown are gross and have not considered indoor fan heat. To obtain **NET** cooling capacity subtract indoor fan heat. For indoor fan heat formula, refer to appropriate airflow table notes.
2. MBH = Total Gross Capacity
3. SHC = Sensible Heat Capacity



# Performance Data

# (7½ Ton) High Efficiency

**Table PD-18 — Gross Cooling Capacities (MBH) 7½ Ton Three Phase THC092A3, A4, AW- Standard Refrigeration Option**

CFM Airflow		Ambient Temperature (F)																																																
		85						95						105						115																														
		Enter. Dry Bulb (F)		61		67		73		Enter. Wet Bulb (F)		61		67		73		61		67		73		61		67		73																						
2700	75	85.7	72.4	95.8	56.8	99.9	37.1	79.3	69.3	92.0	53.7	98.8	35.8	72.8	66.0	85.9	50.8	96.1	34.2	66.1	62.6	78.5	49.1	91.8	32.2	80	87.5	87.0	96.2	68.5	101.1	50.4	81.8	81.8	92.4	67.4	99.6	50.2	76.6	76.6	86.2	64.6	96.7	48.0	71.1	71.1	79.0	61.4	92.0	45.8
	85	92.8	92.8	97.0	81.6	102.3	61.3	88.5	88.5	93.1	81.1	100.3	61.3	83.4	83.4	87.1	78.6	97.0	60.9	77.9	77.9	80.3	75.4	92.3	59.4	90	97.2	97.2	98.3	94.2	103.5	72.4	94.3	94.3	94.3	94.3	101.1	73.1	90.0	90.0	90.0	90.0	97.8	73.7	84.9	84.9	84.9	84.9	92.9	72.7
	80	87.9	77.0	96.6	57.3	100.4	37.6	81.5	73.7	93.5	56.1	99.4	36.4	74.9	70.5	87.8	53.4	96.9	34.8	67.4	67.4	80.5	50.2	92.8	32.8	80	90.5	90.5	97.4	71.2	101.6	51.1	85.6	85.6	94.0	71.0	100.4	50.9	80.2	80.2	88.2	68.7	97.3	49.8	74.5	74.5	81.0	65.5	93.2	47.9
	85	95.6	95.6	98.4	85.1	102.9	62.5	92.2	92.2	95.0	85.8	101.3	63.3	87.3	87.3	89.5	84.1	98.1	63.3	81.8	81.8	82.9	81.2	93.6	62.5	90	99.4	99.4	99.9	98.1	104.1	74.1	97.2	97.2	97.2	97.2	102.1	75.5	93.6	93.6	93.5	93.5	99.1	77.0	88.8	88.8	88.7	88.7	94.4	76.9
3000	75	89.8	81.3	97.5	59.0	100.7	38.1	83.6	78.2	94.6	58.3	99.8	37.1	77.0	75.0	89.2	55.9	97.5	35.4	70.0	70.0	82.1	52.8	93.6	33.4	80	93.2	93.2	98.3	73.5	102.0	51.7	88.9	88.9	95.2	74.2	101.0	52.0	83.4	83.4	89.8	72.6	97.9	50.6	77.6	77.6	82.8	69.5	94.1	49.9
	85	97.6	97.6	99.4	88.0	103.3	67.9	94.9	94.9	96.5	90.0	101.9	64.8	90.5	90.5	91.7	89.4	99.0	67.3	85.2	85.2	85.1	85.1	94.7	65.2	90	100.9	100.9	100.9	100.9	104.6	75.6	99.2	99.2	99.2	99.2	102.8	77.7	96.1	96.1	96.1	96.1	100.1	80.0	91.8	91.8	91.8	91.8	95.7	80.7
	80	91.5	85.3	98.2	60.6	101.0	38.6	85.5	82.6	95.4	60.2	100.2	37.5	78.5	78.5	90.5	58.3	98.0	35.9	72.4	72.4	83.4	55.2	94.3	34.0	80	95.2	95.2	99.0	75.4	102.3	56.8	91.5	91.5	96.3	77.2	101.5	52.7	86.3	86.3	91.3	76.3	98.4	51.4	80.4	80.4	84.4	73.4	94.7	51.4
	85	99.1	99.1	100.2	90.6	103.6	69.8	96.9	96.9	97.8	93.6	102.4	66.1	93.1	93.1	93.1	93.1	99.7	69.8	88.0	88.0	87.9	87.9	95.6	67.8	90	101.9	101.9	101.9	101.9	105.0	76.9	100.7	100.7	100.7	100.7	103.4	79.6	98.0	98.0	97.9	97.9	100.8	82.5	94.0	94.0	94.0	94.0	96.7	84.1

Notes:

- All capacities shown are gross and have not considered indoor fan heat. To obtain **NET** cooling capacity subtract indoor fan heat. For indoor fan heat formula, refer to appropriate airflow table notes.
- MBH = Total Gross Capacity
- SHC = Sensible Heat Capacity



# Performance Data

# (7½ Ton) High Efficiency

**Table PD-19 — Gross Cooling Capacities (MBH) 7½ Ton Three Phase THC092A3, A4, AW – Dehumidification (Hot Gas Reheat) or TXV Option**

		Ambient Temperature (F)																							
		85						95						105						115					
CFM Airflow	Enter. Dry Bulb (F)	Entering Wet Bulb (F)																							
		61		67		73		61		67		73		61		67		73		61		67		73	
		MBH	SHC	MBH	SHC	MBH	SHC	MBH	SHC	MBH	SHC	MBH	SHC	MBH	SHC	MBH	SHC	MBH	SHC	MBH	SHC	MBH	SHC	MBH	SHC
1500*	75	76.3	54.5	85.6	45.2	95.8	34.8	72.9	52.4	81.9	43.2	91.7	32.8	69.2	50.2	77.9	41.1	87.3	30.8	65.3	48.0	73.7	38.9	82.8	28.6
	80	76.5	62.6	85.8	53.0	95.9	43.1	73.0	60.5	82.0	50.9	91.8	41.1	69.3	58.3	78.0	48.7	87.4	39.0	65.4	56.0	73.8	46.5	82.9	36.8
	85	76.6	70.6	85.9	61.0	96.0	51.1	73.1	68.4	82.1	58.9	91.9	49.0	69.4	66.2	78.1	56.7	87.5	46.9	65.6	63.8	73.9	54.4	83.0	44.7
	90	77.3	77.3	86.1	69.0	96.1	59.0	74.5	74.5	82.3	66.9	92.0	57.0	71.5	71.5	78.3	64.6	87.7	54.8	68.3	68.3	74.0	62.3	83.1	52.6
1950*	75	81.6	61.9	91.2	49.4	101.6	36.5	77.7	59.7	87.0	47.2	97.1	34.5	73.7	57.5	82.6	45.0	92.3	32.3	69.4	55.1	78.0	42.7	87.3	30.1
	80	81.9	72.2	91.3	59.6	101.7	47.0	78.1	70.0	87.2	57.5	97.2	44.8	74.0	67.7	82.8	55.2	92.4	42.6	69.8	65.4	78.2	52.9	87.4	40.4
	85	82.3	82.3	91.6	69.9	101.9	57.1	79.2	79.2	87.4	67.7	97.3	55.0	75.8	75.8	83.0	65.4	92.6	52.8	72.3	72.3	78.4	63.1	87.6	50.5
	90	86.9	86.9	91.9	80.0	102.0	67.2	83.6	83.6	87.8	77.8	97.5	65.1	80.2	80.2	83.4	75.5	92.7	62.8	76.5	76.5	78.9	73.2	87.8	60.6
2400	75	85.2	68.7	94.9	53.4	105.5	37.9	81.1	66.5	90.5	51.2	100.7	35.8	76.8	64.2	85.8	48.9	95.6	33.6	72.3	61.8	80.9	46.6	90.3	31.4
	80	86.0	81.3	95.1	65.8	105.6	50.4	82.0	79.1	90.7	63.6	100.8	48.2	77.9	76.9	86.0	61.4	95.7	46.0	73.4	73.4	81.2	59.0	90.4	43.7
	85	89.2	89.2	95.5	78.2	105.8	62.7	85.7	85.7	91.1	76.0	101.0	60.5	82.0	82.0	86.5	73.7	95.9	58.2	78.1	78.1	81.6	71.3	90.6	55.9
	90	94.2	94.2	96.4	90.6	106.1	74.9	90.6	90.6	92.1	88.4	101.3	72.8	86.8	86.8	87.6	86.2	96.2	70.4	82.8	82.8	82.8	82.8	90.9	68.1
2700	75	87.1	73.0	96.8	57.3	107.4	38.7	82.9	70.9	92.2	55.1	102.5	36.6	78.5	68.6	87.4	52.9	97.2	34.4	73.9	66.2	82.3	50.6	91.8	32.2
	80	88.4	87.3	97.0	69.7	107.6	52.5	84.2	84.2	92.5	67.5	102.6	50.4	80.4	80.4	87.7	65.2	97.4	48.1	76.4	76.4	82.7	62.8	91.9	45.8
	85	92.9	92.9	97.6	83.5	107.8	66.2	89.3	89.3	93.1	81.3	102.8	64.0	85.4	85.4	88.4	79.0	97.6	61.8	81.3	81.3	83.4	76.7	92.1	59.4
	90	98.2	98.2	99.1	97.6	108.1	79.8	94.4	94.4	94.4	94.4	103.2	77.6	90.4	90.4	90.4	90.4	98.0	75.3	86.2	86.2	86.2	86.2	92.5	73.0
3000	75	88.7	77.2	98.3	58.4	109.0	39.5	84.5	75.0	93.6	56.1	103.9	37.3	80.0	72.7	88.7	53.8	98.6	35.1	75.3	70.3	83.5	51.4	93.0	32.8
	80	90.8	90.8	98.7	73.5	109.2	54.6	87.0	87.0	94.0	71.3	104.1	52.4	83.1	83.1	89.1	69.0	98.8	50.2	78.9	78.9	84.0	66.6	93.2	47.9
	85	96.2	96.2	99.5	88.8	109.5	69.7	92.4	92.4	94.9	86.6	104.4	67.5	88.3	88.3	90.1	84.3	99.0	65.2	84.0	84.0	85.1	81.9	93.4	62.9
	90	101.7	101.7	101.7	101.7	109.9	84.6	97.8	97.7	97.7	97.7	104.8	82.4	93.6	93.6	93.5	93.5	99.5	80.2	89.1	89.1	89.1	89.1	93.9	77.8
3300	75	90.2	81.4	99.7	60.7	110.4	40.1	85.9	79.1	94.8	58.5	105.2	37.9	81.4	76.8	89.8	56.1	99.7	35.7	76.7	74.4	84.6	53.8	94.0	33.4
	80	93.4	93.4	100.1	77.3	110.6	56.7	89.5	89.5	95.3	75.0	105.4	54.5	85.5	85.5	90.3	72.7	99.9	52.2	81.1	81.1	85.1	70.3	94.2	49.9
	85	99.1	99.1	101.2	94.0	110.9	73.1	95.1	95.1	96.6	91.8	105.6	70.8	90.8	90.8	91.7	89.5	100.2	68.6	86.4	86.4	86.4	86.4	94.5	66.1
	90	104.8	104.8	104.8	104.8	111.4	89.4	100.7	100.7	100.6	100.6	106.2	87.2	96.3	96.3	96.3	96.3	100.8	84.9	91.7	91.7	91.7	91.7	95.2	82.5
3600	75	91.6	85.5	100.8	63.0	111.5	40.8	87.2	83.2	95.9	60.7	106.2	38.6	82.0	82.0	90.8	58.4	100.6	36.3	77.7	77.7	85.5	56.0	94.9	34.0
	80	95.8	95.8	101.3	80.9	111.7	58.6	91.8	91.8	96.5	78.7	106.4	56.4	87.5	87.5	91.4	76.3	100.8	54.1	83.1	83.1	86.1	74.0	95.0	51.8
	85	101.6	101.6	102.8	99.1	112.0	76.3	97.5	97.5	97.4	97.4	106.8	74.2	93.1	93.1	93.0	93.0	101.2	71.9	88.5	88.5	88.5	88.5	95.4	69.4
	90	107.5	107.5	107.5	107.5	112.8	94.0	103.2	103.2	103.2	103.2	107.5	91.8	98.7	98.7	98.7	98.7	102.1	89.5	93.9	93.9	93.9	93.9	96.4	87.2

**Notes:**

1. All capacities shown are gross and have not considered indoor fan heat. To obtain **NET** cooling capacity subtract indoor fan heat. For indoor fan heat formula, refer to appropriate airflow table notes.

2. MBH = Total Gross Capacity

3. SHC = Sensible Heat Capacity

**\*Unit applications below 2400 CFM**

• Electric heaters restricted on applications below 2400 CFM.

• Dehumidification (Hot Gas Reheat) or TXV with Froststat and Crankcase Heaters are required on applications below 2400 CFM.





# Performance Data

# (8½ Ton) High Efficiency

**Table PD-20— Gross Cooling Capacities (MBH) 8½ Ton Three Phase THC102A3, A4, AW— Standard Refrigeration Option**

		Ambient Temperature (F)																							
		85				95				105				115											
CFM Airflow	Enter. Dry Bulb (F)	Entering Wet Bulb (F)																							
		61			67			73			61			67			73								
		MBH	SHC	MBH	SHC	MBH	SHC	MBH	SHC	MBH	SHC	MBH	SHC	MBH	SHC	MBH	SHC	MBH	SHC						
3060	75	94.0	81.8	105.7	62.8	110.8	40.9	86.3	77.8	100.7	59.7	109.7	39.3	79.0	74.2	92.4	56.0	105.5	37.1	71.8	70.5	84.0	53.1	99.6	34.6
	80	96.9	96.9	106.2	77.6	112.0	56.0	90.6	90.6	101.1	75.9	110.1	55.4	84.5	84.5	92.9	72.2	106.1	53.2	78.3	78.3	84.7	68.5	99.8	50.6
	85	103.5	103.5	107.2	92.9	113.2	68.7	98.6	98.6	102.2	92.1	111.6	70.3	92.1	92.1	94.5	88.8	106.4	68.8	85.8	85.8	86.7	85.2	100.0	66.5
3400	75	96.6	87.2	107.1	64.7	111.4	41.5	88.7	83.3	102.4	62.6	110.7	40.1	81.4	79.6	94.4	59.1	106.6	37.9	74.2	74.2	85.9	55.4	101.1	35.5
	80	100.9	100.9	107.7	81.0	112.7	56.9	94.9	94.9	103.0	80.4	111.7	57.5	88.3	88.3	95.2	77.1	107.3	55.7	81.8	81.8	86.8	73.4	101.4	53.1
	85	106.6	106.6	108.9	97.4	114.0	70.2	102.6	102.6	104.4	97.8	112.8	72.9	96.5	96.5	97.6	95.6	108.0	72.4	89.9	89.9	89.8	89.8	101.8	70.8
3740	75	98.9	92.5	107.4	65.9	112.0	42.2	91.2	88.7	103.7	65.4	111.1	40.7	83.5	83.5	96.3	62.2	107.5	38.7	76.9	76.9	87.5	58.4	102.2	36.2
	80	103.7	103.7	108.8	84.0	113.3	57.7	98.7	98.7	104.5	84.5	112.4	58.7	91.7	91.7	97.3	81.9	108.3	57.6	85.0	85.0	88.8	78.2	102.6	55.5
	85	108.8	108.8	110.1	100.9	114.6	76.9	105.4	105.4	106.4	103.0	113.7	75.1	100.2	100.2	100.2	100.2	109.3	75.7	93.4	93.4	93.4	93.4	103.1	74.4
4080	75	100.9	97.3	108.1	67.4	112.5	42.9	93.1	93.1	104.7	67.9	111.5	41.4	86.2	86.2	97.8	65.2	108.2	39.4	79.4	79.4	88.8	61.3	103.0	36.9
	80	105.9	105.9	109.5	86.2	113.8	58.4	101.6	101.6	105.8	88.2	112.8	59.6	94.9	94.9	99.1	86.5	109.2	59.6	87.9	87.9	90.6	82.8	103.5	57.8
	85	110.2	110.2	110.9	103.4	115.1	79.5	107.6	107.6	107.6	107.6	114.1	76.6	103.0	103.0	103.0	103.0	109.9	77.6	96.6	96.6	96.6	96.6	104.2	77.7
	90	112.9	112.9	112.9	112.9	116.5	87.5	112.2	112.2	112.2	115.4	93.4	108.6	108.6	108.6	108.6	111.3	95.9	103.9	103.9	103.9	103.9	105.8	97.0	

**Notes:**

1. All capacities shown are gross and have not considered indoor fan heat. To obtain **NET** cooling capacity subtract indoor fan heat. For indoor fan heat formula, refer to appropriate airflow table notes.
2. MBH = Total Gross Capacity
3. SHC = Sensible Heat Capacity



# Performance Data

# (8½ Ton) High Efficiency

**Table PD-21— Gross Cooling Capacities (MBH) 8½ Ton Three Phase THC102A3, A4, AW – Dehumidification (Hot Gas Reheat) or TXV Option**

		Ambient Temperature (F)																							
		85				95				105				115											
CFM Airflow	Enter. Dry Bulb (F)	Entering Wet Bulb (F)																							
		61		67		73		61		67		73		61		67		73							
		MBH	SHC	MBH	SHC	MBH	SHC	MBH	SHC	MBH	SHC	MBH	SHC	MBH	SHC	MBH	SHC	MBH	SHC	MBH	SHC				
1700*	75	84.4	60.9	94.7	49.8	105.6	38.0	80.3	58.5	90.3	47.5	100.8	35.7	75.9	56.0	85.6	45.0	95.7	33.3	71.3	53.3	80.6	42.4	90.3	30.8
	80	84.5	70.3	94.8	59.1	105.8	47.6	80.4	67.9	90.4	56.7	100.9	45.2	76.1	65.3	85.7	54.1	95.9	42.7	71.5	62.6	80.7	51.5	90.5	40.2
	85	84.8	79.7	94.9	68.4	105.9	56.8	80.8	77.3	90.6	66.0	101.1	54.4	76.5	74.7	85.9	63.4	96.0	51.9	72.2	71.0	80.9	60.8	90.6	49.3
	90	87.0	87.0	95.1	77.7	106.0	66.0	83.6	83.6	90.7	75.2	101.2	63.6	80.0	80.0	86.0	72.6	96.1	61.1	76.2	76.2	81.0	70.0	90.8	58.5
2210*	75	90.0	69.6	100.5	54.9	111.8	39.9	85.6	67.0	95.7	52.4	106.5	37.5	80.8	64.4	90.6	49.8	100.9	35.0	75.8	61.6	85.1	47.1	95.1	32.4
	80	90.5	81.7	100.7	66.8	111.9	51.9	86.1	79.2	95.9	64.3	106.7	49.5	81.5	76.6	90.8	61.7	101.1	47.0	76.6	73.8	85.3	59.0	95.3	44.3
	85	92.3	92.3	101.0	78.8	112.1	63.8	88.6	88.6	96.1	76.3	106.8	61.3	84.6	84.6	91.0	73.6	101.3	58.7	80.3	80.3	85.6	70.9	95.4	56.1
	90	97.5	97.5	101.5	90.7	112.3	75.6	93.6	93.6	96.7	88.2	107.0	73.1	89.5	89.5	91.7	87.1	101.5	70.5	85.1	85.1	86.4	82.9	95.6	67.9
2720	75	94.0	77.6	104.4	59.5	115.8	41.4	89.3	75.1	99.3	57.0	110.2	38.9	84.3	72.4	93.8	54.4	104.3	36.4	79.0	69.6	88.1	51.7	98.2	33.8
	80	95.2	92.6	104.7	74.1	116.0	55.9	90.7	90.1	99.5	71.5	110.4	53.4	86.0	86.0	94.1	68.9	104.5	50.9	81.4	81.4	88.4	66.2	98.4	48.2
	85	99.8	99.8	105.2	88.7	116.2	70.3	95.7	95.7	100.1	86.1	110.6	67.8	91.3	91.3	94.7	83.5	104.7	65.2	86.6	86.6	89.1	80.7	98.6	62.5
	90	105.4	105.4	106.5	103.4	116.5	84.7	101.1	101.1	101.6	100.9	110.9	82.1	96.6	96.6	96.6	96.6	105.1	79.5	91.8	91.8	91.8	91.8	98.9	76.9
3060	75	96.1	82.8	106.4	63.2	117.8	42.2	91.3	80.2	101.0	60.7	112.1	39.8	86.2	77.5	95.4	58.1	106.0	37.2	80.8	74.7	89.6	55.4	99.7	34.6
	80	98.1	98.1	106.7	78.8	118.1	58.5	93.8	93.8	101.4	76.2	112.2	55.9	89.3	89.3	95.8	73.5	106.2	53.3	84.6	84.6	90.0	70.8	99.9	50.7
	85	103.8	103.8	107.5	95.1	118.3	74.5	99.5	99.5	102.3	92.5	112.5	72.0	94.8	94.8	96.9	89.9	106.4	69.4	89.9	89.9	91.2	87.2	100.1	66.7
	90	109.7	109.7	109.7	109.7	118.7	90.6	105.2	105.2	105.2	105.2	112.9	88.1	100.4	100.4	100.4	100.4	106.9	85.4	95.4	95.4	95.4	95.4	100.7	82.7
3400	75	97.9	87.9	108.0	65.4	119.4	43.1	93.0	85.3	102.5	62.8	113.5	40.6	87.8	82.6	96.8	60.1	107.4	38.1	82.5	79.9	90.8	57.4	100.9	35.4
	80	101.3	101.3	108.4	83.4	119.7	60.9	96.9	96.9	103.0	80.8	113.7	58.4	92.2	92.2	97.3	78.1	107.5	55.8	87.3	87.3	91.4	75.3	101.1	53.1
	85	107.3	107.3	109.6	101.4	120.0	78.7	102.8	102.8	104.3	98.8	114.0	76.1	98.0	98.0	98.9	96.2	107.8	73.5	92.9	92.9	92.9	92.9	101.4	70.8
	90	113.4	113.4	113.4	113.4	120.6	96.4	108.8	108.8	108.7	108.7	114.6	93.8	103.8	103.8	103.8	103.8	108.6	91.2	98.6	98.6	98.6	98.6	102.2	88.5
3740	75	99.6	92.9	109.3	68.2	120.7	43.8	94.6	90.3	103.8	65.6	114.8	41.4	89.4	87.6	98.0	62.9	108.5	38.8	83.8	83.8	91.9	60.2	101.9	36.2
	80	104.1	104.1	109.9	87.9	121.0	63.3	99.5	99.5	104.4	85.3	114.9	60.7	94.7	94.7	98.7	82.6	108.7	58.1	89.6	89.6	92.6	79.8	102.1	55.4
	85	110.4	110.4	111.6	107.6	121.4	82.7	105.7	105.7	106.3	105.1	115.3	80.1	100.7	100.7	100.6	100.6	109.0	77.5	95.4	95.4	95.4	95.4	102.5	74.9
	90	116.7	116.7	116.7	116.7	122.1	102.0	111.8	111.8	111.8	111.8	116.2	99.5	106.7	106.7	106.7	106.7	110.0	96.8	101.2	101.2	101.2	101.2	103.6	94.2
4080	75	101.1	97.8	110.5	71.0	121.9	44.6	96.1	95.2	104.9	68.3	115.8	42.1	90.8	90.8	98.9	65.7	109.4	39.5	85.7	85.7	92.7	62.9	102.8	36.8
	80	106.6	106.6	111.2	92.2	122.1	65.7	101.9	101.9	105.7	89.6	116.0	63.1	96.9	96.9	99.8	87.0	109.6	60.5	91.6	91.6	93.8	84.2	103.0	57.8
	85	113.1	113.1	113.0	113.0	122.5	86.7	108.2	108.2	108.1	108.1	116.4	84.1	103.0	103.0	103.0	103.0	110.0	81.5	97.6	97.6	97.6	97.6	103.5	78.8
	90	119.5	119.5	119.5	119.5	123.6	107.6	114.5	114.5	114.5	114.5	117.5	105.0	109.2	109.2	109.2	109.2	111.3	102.4	103.6	103.6	103.6	103.6	104.9	99.8

**Notes:**

1. All capacities shown are gross and have not considered indoor fan heat. To obtain **NET** cooling capacity subtract indoor fan heat. For indoor fan heat formula, refer to appropriate airflow table notes.

2. MBH = Total Gross Capacity

3. SHC = Sensible Heat Capacity

**\*Unit applications below 2720 CFM**

• Electric heaters restricted on applications below 2720 CFM.

• Dehumidification (Hot Gas Reheat) or TXV with Froststat and Crankcase Heaters are required on applications below 2720 CFM.



# Performance Data

# (10 Ton) High Efficiency

**Table PD-22 — Gross Cooling Capacities (MBH) 10 Ton Three Phase THC120A3, A4, AW— Standard Refrigeration Option**

		Ambient Temperature (F)																													
		85						95						105						115											
CFM Airflow	Enter. Dry Bulb (F)	Entering Wet Bulb (F)																													
		61			67			73			61			67			73			61			67			73					
		MBH	SHC	MBH	SHC	MBH	SHC	MBH	SHC	MBH	SHC	MBH	SHC	MBH	SHC	MBH	SHC	MBH	SHC	MBH	SHC	MBH	SHC	MBH	SHC	MBH	SHC				
3600	75	107.0	94.4	117.4	75.0	123.4	46.0	98.7	90.1	114.7	68.8	121.9	44.4	88.5	88.5	107.2	65.3	118.6	42.2	82.3	78.8	97.8	61.1	113.6	39.6	90.6	90.6	98.5	80.1	114.3	58.3
	80	110.9	108.6	119.9	88.2	125.0	62.5	104.5	104.1	115.2	87.5	123.4	62.3	97.7	97.7	107.8	84.3	119.4	60.8	90.6	90.6	98.5	80.1	114.3	58.3	99.9	99.9	100.0	100.0	114.8	76.5
	85	117.6	117.6	120.9	105.0	126.6	76.7	113.1	113.1	116.5	105.8	124.9	78.1	106.9	106.9	107.0	107.0	120.9	78.1	99.9	99.9	100.0	100.0	114.8	76.5	109.0	109.0	109.0	109.0	115.8	94.3
	90	122.5	122.5	122.4	122.4	128.2	91.1	119.6	119.6	119.6	117.1	126.4	94.1	115.0	115.0	114.7	114.6	121.6	94.3	109.0	109.0	109.0	109.0	115.8	94.3	109.0	109.0	109.0	109.0	115.8	94.3
4000	75	109.8	100.5	119.4	71.9	122.5	46.5	99.7	99.7	116.1	71.5	121.7	45.0	92.5	92.5	110.1	69.1	119.4	43.0	85.6	83.4	100.9	65.0	114.6	40.5	94.8	94.8	101.9	86.0	115.5	61.1
	80	114.6	114.1	120.8	90.1	124.1	68.3	109.3	109.3	117.0	91.2	123.4	62.7	102.3	102.3	110.8	89.9	120.6	62.5	94.8	94.8	101.9	86.0	115.5	61.1	104.7	104.7	105.8	102.6	116.3	79.7
	85	120.5	120.5	122.3	107.9	125.9	76.4	117.0	117.0	118.6	110.2	125.0	78.8	111.6	111.6	111.8	111.8	122.1	80.4	104.7	104.7	105.8	102.6	116.3	79.7	113.1	113.1	113.3	113.3	117.7	98.6
	90	125.2	125.2	124.2	124.2	127.6	90.9	122.4	122.4	121.7	120.9	126.6	95.1	118.5	118.5	118.3	118.3	123.6	98.4	113.1	113.1	113.3	113.3	117.7	98.6	113.1	113.1	113.3	113.3	117.7	98.6
4400	75	112.3	106.1	121.2	74.8	124.6	47.6	103.6	103.6	117.1	75.5	123.0	46.0	96.7	93.9	111.2	72.2	120.0	43.7	88.6	88.0	102.0	68.2	115.3	41.2	98.8	98.8	103.5	91.1	116.1	62.8
	80	117.6	117.6	122.5	94.7	126.3	64.2	113.0	113.0	118.4	95.8	124.7	64.4	106.3	106.3	112.2	94.9	121.5	64.3	98.8	98.8	103.5	91.1	116.1	62.8	109.1	109.1	108.8	107.4	117.2	83.2
	85	122.4	122.4	124.3	113.8	128.0	79.6	119.6	119.6	119.6	119.6	126.4	81.8	115.1	115.1	115.5	111.7	122.7	83.0	109.1	109.1	108.8	107.4	117.2	83.2	116.1	116.1	116.1	116.1	118.8	103.3
	90	126.0	126.0	127.1	125.0	129.6	95.2	124.3	124.3	124.2	124.2	128.0	99.4	120.9	120.9	120.9	120.9	123.9	101.2	116.1	116.1	116.1	116.1	118.8	103.3	116.1	116.1	116.1	116.1	118.8	103.3
4800	75	113.4	113.4	121.8	76.2	125.0	48.4	107.6	104.0	118.5	77.0	123.5	46.9	99.6	98.2	112.7	75.4	120.5	44.8	91.6	91.6	103.7	71.6	115.9	41.9	102.3	102.3	105.5	96.3	117.2	66.8
	80	119.5	119.5	123.2	97.0	126.7	64.8	115.8	115.8	119.8	99.6	125.2	65.3	109.8	109.8	113.9	99.4	122.1	65.5	102.3	102.3	105.5	96.3	117.2	66.8	111.8	111.8	111.8	111.8	118.5	86.4
	85	124.3	124.3	125.2	116.6	128.4	80.7	121.5	121.5	121.5	121.5	126.9	83.3	117.5	117.5	117.6	115.4	123.7	85.6	111.8	111.8	111.8	111.8	118.5	86.4	118.2	118.2	118.2	118.2	120.3	107.5
	90	127.5	127.5	128.0	126.7	130.1	96.9	126.0	126.0	125.5	125.5	128.6	101.5	122.6	122.6	123.0	123.0	125.5	105.5	118.2	118.2	118.2	118.2	120.3	107.5	118.2	118.2	118.2	120.3	107.5	

**Notes:**

1. All capacities shown are gross and have not considered indoor fan heat. To obtain **NET** cooling capacity subtract indoor fan heat. For indoor fan heat formula, refer to appropriate airflow table notes.
2. MBH = Total Gross Capacity
3. SHC = Sensible Heat Capacity



# Performance Data

# (10 Ton) High Efficiency

**Table PD-23— Gross Cooling Capacities (MBH) 10Ton THC120A3, A4, AW – Dehumidification (Hot Gas Reheat) or TXV Option**

CFM		Ambient Temperature (F)																																																																																																		
		85						95						105						115																																																																																
		Enter. Dry Bulb (F)		61		67		73		61		67		73		61		67		73		61		67		73																																																																										
Airflow		MBH	SHC	MBH	SHC	MBH	SHC	MBH	SHC	MBH	SHC	MBH	SHC	MBH	SHC	MBH	SHC	MBH	SHC	MBH	SHC	MBH	SHC	MBH	SHC	MBH	SHC																																																																									
2000*	75	94.2	68.9	105.8	56.2	118.4	42.6	89.7	66.2	101.0	53.6	113.2	40.0	84.8	63.4	95.8	50.9	107.6	37.3	79.7	60.4	90.2	48.1	101.5	34.6	80	94.4	79.8	106.0	66.8	118.6	53.6	89.9	77.1	101.2	64.1	113.4	51.0	85.0	74.2	96.0	61.4	107.8	48.3	79.9	71.2	90.4	58.4	101.7	45.4	85	93.0	93.0	106.3	77.6	118.8	64.3	90.4	86.3	101.4	74.9	113.6	61.7	86.1	82.8	96.2	72.1	108.0	59.0	81.6	79.1	90.7	69.2	101.9	56.1	90	98.0	97.2	106.4	88.3	119.0	75.0	94.4	94.4	101.6	85.6	113.8	72.4	90.4	90.4	96.4	82.8	108.2	69.6	86.1	86.1	90.9	79.8	102.1	66.7
2600*	75	100.5	78.8	112.6	62.6	125.6	44.8	95.6	76.0	107.3	59.9	119.9	42.2	90.4	73.0	101.6	57.1	113.8	39.5	84.8	70.0	95.6	54.1	107.2	36.6	80	101.1	92.6	112.9	75.8	125.8	58.8	96.4	89.9	107.6	73.1	120.1	56.1	89.7	89.7	101.9	70.2	114.0	53.3	86.0	81.9	95.8	67.1	107.4	50.4	85	104.0	102.0	113.2	89.6	126.1	72.5	99.7	98.7	107.9	86.8	120.4	69.8	95.4	95.4	102.3	83.9	114.2	67.0	90.6	90.6	96.2	80.9	107.6	64.0	90	109.9	109.9	113.9	103.3	126.4	86.1	105.6	105.6	108.7	100.5	120.7	83.4	101.1	101.1	101.1	101.1	114.5	80.6	96.2	96.2	97.5	92.3	107.9	77.6
3200	75	104.9	87.8	117.1	67.4	130.2	46.6	99.8	85.0	111.5	65.7	124.2	44.0	94.3	82.0	110.8	64.8	117.7	41.2	88.4	78.9	99.0	59.8	110.7	38.2	80	106.6	102.0	117.4	84.1	130.5	63.4	102.0	98.4	111.8	81.3	124.5	60.6	97.0	94.6	105.8	78.4	118.0	57.8	91.6	90.5	99.4	75.3	111.0	54.8	85	112.2	112.2	118.1	100.7	130.8	79.9	107.8	107.8	112.6	98.0	124.7	77.2	103.0	103.0	106.7	95.0	118.2	74.3	97.7	97.7	100.4	91.9	111.2	71.3	90	118.6	118.6	118.8	118.8	131.1	96.5	114.2	114.2	115.0	110.5	125.1	93.7	109.2	109.2	109.6	106.5	118.7	90.8	103.8	103.8	103.9	102.2	111.7	87.8
3600	75	107.3	93.6	119.4	70.7	132.5	47.7	102.1	90.8	113.6	67.9	126.3	45.0	96.5	87.8	107.2	64.9	119.4	42.1	90.4	84.7	100.6	61.8	112.1	39.1	80	110.3	107.5	119.7	89.4	132.8	66.3	105.6	104.0	114.0	86.6	126.6	63.5	100.4	100.3	107.6	83.5	119.6	60.5	95.1	95.1	101.1	80.4	112.4	57.5	85	116.7	116.7	120.8	107.9	133.2	84.7	112.2	112.2	115.2	105.1	126.9	82.0	107.1	107.1	108.9	102.1	119.9	79.0	101.4	101.4	101.4	101.4	112.7	75.9	90	123.5	123.5	124.2	120.7	133.7	103.1	118.8	118.8	119.0	116.9	127.5	100.3	113.6	113.6	113.2	112.8	120.6	97.3	107.7	107.7	107.7	107.7	113.4	94.2
4000	75	110.8	101.0	122.7	75.2	136.1	49.4	105.2	97.9	116.6	72.2	129.5	46.5	99.5	94.8	110.2	69.2	122.6	43.6	92.8	92.8	103.6	66.0	115.5	40.6	80	115.3	115.3	123.1	96.0	136.3	70.2	110.3	110.3	117.0	93.1	129.7	67.3	105.0	105.0	110.7	90.0	122.9	64.3	99.5	99.5	104.1	86.8	115.7	61.3	85	122.3	122.3	124.5	116.8	136.6	90.7	117.2	117.2	117.2	117.2	130.0	87.8	111.8	111.8	111.8	111.8	123.1	84.8	106.2	106.2	106.6	103.4	116.0	81.8	90	129.5	129.5	129.3	129.3	137.2	111.3	124.2	124.2	124.2	124.2	130.6	108.4	118.7	118.7	118.6	118.6	123.9	105.4	112.9	112.9	112.8	112.8	116.9	102.4
4400	75	112.7	106.4	124.3	78.3	137.7	50.3	106.1	106.1	118.0	75.3	130.9	47.4	100.8	100.8	111.5	72.2	123.9	44.4	95.5	93.3	104.7	69.1	116.7	41.4	80	118.4	118.4	124.8	100.9	137.9	72.8	113.2	113.2	118.6	98.0	131.2	69.9	107.8	107.8	112.2	94.9	124.2	67.0	102.1	102.1	105.5	91.7	116.9	63.9	85	125.7	125.7	125.7	125.7	138.2	95.2	120.4	120.4	120.4	120.4	131.5	92.3	114.8	114.8	115.1	112.5	124.5	89.3	109.0	109.0	109.0	107.8	117.3	86.3	90	133.1	133.1	133.1	133.1	139.0	117.5	127.6	127.6	127.6	127.6	132.4	114.6	121.9	121.9	121.9	121.9	125.5	111.6	115.9	115.9	115.9	115.9	118.5	108.6
4800	75	113.7	113.7	125.6	81.3	139.0	51.1	108.5	108.5	119.2	78.3	132.2	48.2	103.0	103.0	112.6	75.2	125.1	45.3	97.3	96.6	105.8	72.0	117.7	42.2	80	121.1	121.1	126.2	105.7	139.3	75.4	115.8	115.8	120.0	102.7	132.4	72.5	110.2	110.2	113.5	99.7	125.3	69.5	104.4	104.4	106.8	96.5	118.0	66.5	85	128.6	128.6	128.6	128.6	139.6	99.5	123.2	123.2	123.4	121.4	132.8	96.6	117.4	117.4	117.4	116.7	125.7	93.6	111.5	111.5	111.4	111.4	118.4	90.6	90	136.2	136.2	136.2	136.2	140.7	123.6	130.6	130.6	130.6	130.6	134.0	120.7	124.7	124.7	124.7	124.7	127.1	117.6	118.5	118.5	118.5	118.5	118.5	118.5

Notes:

- All capacities shown are gross and have not considered indoor fan heat. To obtain **NET** cooling capacity subtract indoor fan heat. For indoor fan heat formula, refer to appropriate airflow table notes.
  - MBH = Total Gross Capacity
  - SHC = Sensible Heat Capacity
- \*Unit applications below 3200 CFM**
- Electric heaters restricted on applications below 3200 CFM.
  - Dehumidification (Hot Gas Reheat) or TXV with Froststat and Crankcase Heaters are required on applications below 3200 CFM.



# Performance Data

# (3, 4, 5 Ton) Standard Efficiency

**Table PD-24— Direct Drive Evaporator Fan Performance 3, 4 and 5 Ton TSC036A, TSC048A, TSC060A**

		External Static Pressure (Inches of Water) & Motor Power (Bhp) <sup>1</sup>									
		Standard Motor						Oversized Motor			
Tons	Unit Model No.	CFM	High Speed		Low Speed		High Speed		Low Speed		
			ESP	BHP	ESP	BHP	ESP	BHP	ESP	BHP	
3	TSC036A Horizontal	960	0.81	0.36	0.61	0.28	0.96	0.39	0.89	0.35	
		1020	0.77	0.37	0.57	0.28	0.94	0.41	0.86	0.47	
		1080	0.73	0.38	0.50	0.29	0.91	0.43	0.82	0.39	
		1140	0.69	0.39	0.42	0.29	0.88	0.44	0.77	0.40	
		1200	0.66	0.40	0.34	0.30	0.84	0.45	0.74	0.41	
		1260	0.60	0.41	0.26	0.30	0.80	0.46	0.70	0.42	
		1320	0.55	0.42	0.14	0.31	0.75	0.48	0.65	0.44	
		1380	0.49	0.42	0.05	0.31	0.70	0.49	0.59	0.45	
		1440	0.44	0.43	—	—	0.64	0.52	0.54	0.48	
4	TSC048A Horizontal	1280	0.93	0.53	0.81	0.47	1.20	0.67	0.99	0.56	
		1360	0.87	0.54	0.75	0.47	1.15	0.68	0.94	0.58	
		1440	0.80	0.54	0.68	0.48	1.10	0.70	0.88	0.60	
		1520	0.73	0.55	0.60	0.48	1.05	0.73	0.81	0.63	
		1600	0.66	0.55	0.51	0.49	1.00	0.75	0.74	0.64	
		1680	0.57	0.56	0.38	0.49	0.95	0.78	0.65	0.66	
		1760	0.47	0.56	0.23	0.50	0.90	0.82	0.50	0.68	
		1840	0.37	0.57	0.13	0.50	0.83	0.83	0.35	0.70	
		1920	0.27	0.57	—	—	0.75	0.85	0.25	0.73	
5	TSC060A <sup>3</sup> Horizontal	1600	0.90	0.78	0.82	0.64	1.20	0.90	1.05	0.85	
		1700	0.85	0.82	0.68	0.65	1.15	0.94	0.95	0.89	
		1800	0.80	0.85	0.56	0.65	1.05	0.98	0.85	0.91	
		1900	0.70	0.88	0.46	0.65	0.98	1.02	0.75	0.94	
		2000	0.60	0.90	0.30	0.66	0.90	1.05	0.65	0.95	
		2100	0.50	0.93	0.14	0.66	0.80	1.10	0.50	0.96	
		2200	0.40	0.95	0.05	0.67	0.70	1.12	0.35	0.96	
		2300	0.30	0.97	—	—	0.60	1.17	0.15	0.97	
		2400	0.20	1.00	—	—	0.48	1.20	—	—	
3	TSC036A Downflow	960	0.86	0.36	0.61	0.28	1.01	0.39	0.89	0.35	
		1020	0.82	0.37	0.62	0.28	0.99	0.41	0.91	0.47	
		1080	0.78	0.38	0.55	0.29	0.96	0.43	0.87	0.39	
		1140	0.74	0.39	0.47	0.29	0.93	0.44	0.82	0.40	
		1200	0.71	0.40	0.39	0.30	0.89	0.45	0.79	0.41	
		1260	0.65	0.41	0.31	0.30	0.85	0.46	0.75	0.42	
		1320	0.60	0.42	0.19	0.31	0.80	0.48	0.70	0.44	
		1380	0.54	0.42	0.10	0.31	0.75	0.49	0.64	0.45	
		1440	0.49	0.43	—	—	0.69	0.52	0.59	0.48	
4	TSC048A Downflow	1280	0.98	0.53	0.86	0.47	1.25	0.67	1.04	0.56	
		1360	0.92	0.54	0.80	0.47	1.20	0.68	0.99	0.58	
		1440	0.85	0.54	0.73	0.48	1.15	0.70	0.93	0.60	
		1520	0.78	0.55	0.65	0.48	1.10	0.73	0.86	0.63	
		1600	0.71	0.55	0.56	0.49	1.05	0.75	0.79	0.64	
		1680	0.62	0.56	0.43	0.49	1.00	0.78	0.70	0.66	
		1760	0.52	0.56	0.28	0.50	0.95	0.82	0.55	0.68	
		1840	0.42	0.57	0.18	0.50	0.88	0.83	0.40	0.70	
		1920	0.32	0.57	—	—	0.80	0.85	—	—	
5	TSC060A <sup>3</sup> Downflow	1600	0.95	0.78	0.87	0.64	1.25	0.90	1.10	0.85	
		1700	0.90	0.82	0.73	0.65	1.20	0.94	1.00	0.89	
		1800	0.85	0.85	0.61	0.65	1.10	0.98	0.90	0.91	
		1900	0.75	0.88	0.51	0.65	1.03	1.02	0.80	0.94	
		2000	0.65	0.90	0.35	0.66	0.95	1.05	0.70	0.95	
		2100	0.55	0.93	0.19	0.66	0.85	1.10	0.55	0.96	
		2200	0.45	0.95	0.10	0.67	0.75	1.12	0.40	0.96	
		2300	0.35	0.97	—	—	0.65	1.17	0.20	0.97	
		2400	0.25	1.00	—	—	0.53	1.20	—	—	

Fan motor heat (MBH) = 3.72 x Fan Bhp + .24.

Factory supplied motors, in commercial equipment, are definite purpose motors, specifically designed and tested to operate reliably and continuously at all cataloged conditions. Using the full horsepower range of our fan motors as shown in our tabular data will not result in nuisance tripping or premature motor failure. Our product's warranty will not be affected.

Notes:

1. Data includes pressure drop due to wet coil and filters.
2. 5 ton oversized motor performance is with 12 x 11 FC blower wheel.
3. YSC060AK uses a 1.0 hp direct drive motor and 12x11 FC centrifugal blower wheel. Refer to oversized motor column for the standard motor performance data.



# Performance Data

# (3 Ton) Standard Efficiency

**Table PD-25 – Belt Drive Evaporator Fan Performance – 3 Ton – TSC036A3,A4,AW – Downflow Airflow**

CFM	External Static Pressure (Inches of Water)																			
	.10		.20		.30		.40		.50		.60		.70		.80		.90		1.00	
	RPM	BHP	RPM	BHP	RPM	BHP	RPM	BHP	RPM	BHP	RPM	BHP	RPM	BHP	RPM	BHP	RPM	BHP	RPM	BHP
<b>1-HP Standard Motor &amp; Field Supplied Low Static Drive (1)</b>										<b>1-HP Standard Motor &amp; Drive</b>										
960	—	—	528	0.12	599	0.16	658	0.20	713	0.24	763	0.29	810	0.33	855	0.38	898	0.43	939	0.49
1080	—	—	557	0.15	625	0.19	685	0.24	738	0.28	786	0.33	832	0.38	876	0.43	917	0.48	957	0.54
1200	—	—	588	0.19	652	0.23	712	0.28	764	0.33	811	0.38	856	0.43	898	0.48	939	0.54	978	0.59
1320	552	0.18	622	0.23	681	0.27	738	0.32	790	0.38	838	0.44	882	0.49	923	0.55	962	0.60	1000	0.66
1440	588	0.23	657	0.28	713	0.33	765	0.37	817	0.43	865	0.50	909	0.56	949	0.62	987	0.68	1024	0.74

**Table PD-25 – Continued**

CFM	External Static Pressure (Inches of Water)									
	1.10		1.20		1.30		1.40		1.50	
	RPM	BHP	RPM	BHP	RPM	BHP	RPM	BHP	RPM	BHP
<b>1-HP Standard Motor &amp; Drive</b>										
960	978	0.54	1016	0.60	1052	0.66	1086	0.72	1120	0.78
1080	985	0.59	1033	0.65	1069	0.71	1103	0.78	1136	0.84
1200	1015	0.65	1051	0.71	1086	0.77	1120	0.84	1154	0.91
1320	1036	0.72	1072	0.78	1106	0.85	1138	0.91	1171	0.98
1440	1060	0.80	1094	0.86	1128	0.93	1160	1.00	1192	1.07

**1-HP Standard Motor & Field Supplied High Static Drive (2)**

For Standard Evaporator Fan Speed (RPM), reference Table PD-56.  
 Notes:  
 Data includes pressure drop due to standard filters and wet coils.  
 No accessories or options are included in pressure drop data.  
 Refer to Table PD-61 to determine additional static pressure drop due to other options/accessories.  
 Fan Motor Heat (MBH) = 2.829 x Fan BHP + .4024.  
 1. Field Supplied Fan Sheave AK69 required. Field Supplied Belt may be necessary.  
 2. Field Supplied Fan Sheave AK41 required. Field Supplied Belt may be necessary.  
 Factory supplied motors, in commercial equipment, are definite purpose motors, specifically designed and tested to operate reliably and continuously at all cataloged conditions. Using the full horsepower range of our fan motors as shown in our tabular data will not result in nuisance tripping or premature motor failure. Our product's warranty will not be affected.

**Table PD-26 – Belt Drive Evaporator Fan Performance – 3 Ton – TSC036A3,A4,AW – Horizontal Airflow**

CFM	External Static Pressure (Inches of Water)																			
	.10		.20		.30		.40		.50		.60		.70		.80		.90		1.00	
	RPM	BHP	RPM	BHP	RPM	BHP	RPM	BHP	RPM	BHP	RPM	BHP	RPM	BHP	RPM	BHP	RPM	BHP	RPM	BHP
<b>1-HP Standard Motor &amp; Field Supplied Low Static Drive (1)</b>										<b>1-HP Standard Motor &amp; Drive</b>										
960	—	—	588	0.15	661	0.19	725	0.24	782	0.29	832	0.35	878	0.40	919	0.46	958	0.51	996	0.56
1080	531	0.13	622	0.18	694	0.24	756	0.29	813	0.34	864	0.40	910	0.46	954	0.52	993	0.59	1031	0.65
1200	570	0.17	654	0.23	727	0.28	787	0.34	843	0.40	895	0.46	942	0.52	986	0.59	1026	0.66	1064	0.73
1320	610	0.22	687	0.28	760	0.34	821	0.40	875	0.46	925	0.53	973	0.59	1017	0.66	1058	0.73	1095	0.81
1440	651	0.27	723	0.33	793	0.40	855	0.47	908	0.53	956	0.60	1003	0.67	1047	0.75	1088	0.82	1127	0.89

**1-HP Standard Motor & Field Supplied High Static Drive (2)**

**Table PD-26 – Continued**

CFM	External Static Pressure (Inches of Water)									
	1.10		1.20		1.30		1.40		1.50	
	RPM	BHP	RPM	BHP	RPM	BHP	RPM	BHP	RPM	BHP
<b>1-HP Standard Motor &amp; Drive</b>										
960	1032	0.62	1066	0.67	1101	0.73	1133	0.79	1166	0.86
1080	1065	0.70	1099	0.76	1132	0.82	1164	0.89	1194	0.95
1200	1099	0.80	1133	0.86	1166	0.93	1197	0.99	1227	1.06
1320	1132	0.88	1167	0.96	1200	1.04	1230	1.11	1261	1.19
1440	1164	0.97	1199	1.05	1232	1.14	1263	1.22	1294	1.30

**1-HP Standard Motor & Field Supplied High Static Drive (2)**

For Standard Evaporator Fan Speed (RPM), reference Table PD-56.  
 Notes:  
 Data includes pressure drop due to standard filters and wet coils.  
 No accessories or options are included in pressure drop data.  
 Refer to Table PD-61 to determine additional static pressure drop due to other options/accessories.  
 Fan Motor Heat (MBH) = 2.829 x Fan BHP + .4024.  
 1. Field Supplied Fan Sheave AK69 required. Field Supplied Belt may be necessary.  
 2. Field Supplied Fan Sheave AK41 required. Field Supplied Belt may be necessary.  
 Factory supplied motors, in commercial equipment, are definite purpose motors, specifically designed and tested to operate reliably and continuously at all cataloged conditions. Using the full horsepower range of our fan motors as shown in our tabular data will not result in nuisance tripping or premature motor failure. Our product's warranty will not be affected.

# Performance Data

# (4 Ton) Standard Efficiency

**Table PD-27 — Belt Drive Evaporator Fan Performance — 4 Ton — TSC048A3,A4,AW — Downflow Airflow**

CFM	External Static Pressure (Inches of Water)																			
	.10		.20		.30		.40		.50		.60		.70		.80		.90		1.00	
	RPM	BHP	RPM	BHP	RPM	BHP	RPM	BHP	RPM	BHP	RPM	BHP	RPM	BHP	RPM	BHP	RPM	BHP	RPM	BHP
<b>1-HP Standard Motor &amp; Field Supplied Low Static Drive (1)</b>										<b>1-HP Standard Motor &amp; Drive</b>										
1280	—	—	616	0.22	677	0.26	734	0.31	787	0.37	834	0.42	878	0.48	919	0.53	959	0.59	997	0.64
1440	596	0.23	663	0.29	719	0.33	772	0.38	823	0.44	871	0.51	914	0.57	954	0.63	993	0.69	1029	0.75
1600	647	0.31	711	0.37	764	0.42	813	0.47	860	0.53	906	0.59	951	0.66	992	0.74	1029	0.80	1065	0.87
1760	701	0.41	758	0.46	811	0.52	856	0.58	901	0.64	944	0.70	986	0.77	1027	0.85	1066	0.93	1102	1.00
1920	755	0.52	807	0.57	859	0.64	903	0.71	945	0.77	985	0.83	1024	0.89	1063	0.97	1101	1.05	1137	1.14

**Table PD-27 — Continued**

CFM	External Static Pressure (Inches of Water)									
	1.10		1.20		1.30		1.40		1.50	
	RPM	BHP	RPM	BHP	RPM	BHP	RPM	BHP	RPM	BHP
<b>1-HP Standard Motor &amp; Drive</b>										
1280	1033	0.70	1069	0.77	1103	0.83	1136	0.89	1170	0.96
1440	1066	0.81	1099	0.87	1133	0.94	1165	1.01	1196	1.08
1600	1099	0.93	1132	1.00	1166	1.07	1196	1.14	1228	1.21
1760	1136	1.08	1168	1.15	1200	1.22	1229	1.29	—	—
1920	1172	1.23	1205	1.31	1236	1.39	—	—	—	—

For Standard Evaporator Fan Speed (RPM), reference Table PD-56.  
Notes:

Data includes pressure drop due to standard filters and wet coils.

No accessories or options are included in pressure drop data.

Refer to Table PD-61 to determine additional static pressure drop due to other options/accessories.

Fan Motor Heat (MBH) = 2.829 x Fan BHP + .4024.

1. Field Supplied Fan Sheave AK61 required. Field Supplied Belt may be necessary.

Factory supplied motors, in commercial equipment, are definite purpose motors, specifically designed and tested to operate reliably and continuously at all cataloged conditions. Using the full horsepower range of our fan motors as shown in our tabular data will not result in nuisance tripping or premature motor failure. Our product's warranty will not be affected.

**Table PD-28 — Belt Drive Evaporator Fan Performance — 4 Ton — TSC048A3,A4,AW — Horizontal Airflow**

CFM	External Static Pressure (Inches of Water)																			
	.10		.20		.30		.40		.50		.60		.70		.80		.90		1.00	
	RPM	BHP	RPM	BHP	RPM	BHP	RPM	BHP	RPM	BHP	RPM	BHP	RPM	BHP	RPM	BHP	RPM	BHP	RPM	BHP
<b>1-HP Standard Motor &amp; Field Supplied Low Static Drive (1)</b>									<b>1-HP Standard Motor &amp; Drive</b>											
1280	604	0.20	683	0.26	756	0.32	816	0.39	869	0.45	920	0.51	967	0.57	1011	0.64	1052	0.71	1090	0.79
1440	660	0.28	731	0.34	800	0.41	862	0.48	914	0.54	963	0.61	1009	0.68	1053	0.76	1094	0.83	1133	0.91
1600	717	0.36	783	0.43	846	0.51	907	0.58	961	0.66	1008	0.73	1053	0.81	1095	0.89	1135	0.97	1174	1.05
1760	774	0.47	837	0.54	894	0.62	952	0.70	1006	0.79	1054	0.87	1098	0.95	1139	1.04	1178	1.12	1216	1.21
1920	833	0.59	892	0.67	946	0.76	998	0.85	1050	0.94	1100	1.03	1144	1.12	1185	1.21	1224	1.30	1259	1.39

**1-HP Standard Motor & Field Supplied High Static Drive**

**Table PD-28 — Continued**

CFM	External Static Pressure (Inches of Water)									
	1.10		1.20		1.30		1.40		1.50	
	RPM	BHP	RPM	BHP	RPM	BHP	RPM	BHP	RPM	BHP
<b>1-HP Standard Motor &amp; Drive</b>										
1280	1125	0.86	1160	0.94	1192	1.01	1223	1.08	1254	1.15
1440	1169	0.98	1204	1.07	1237	1.15	1269	1.23	1300	1.32
1600	1211	1.13	1247	1.21	1280	1.30	1312	1.39	1343	1.48
1760	1253	1.30	1289	1.39	1322	1.47	—	—	—	—
1920	1295	1.48	—	—	—	—	—	—	—	—
<b>1-HP Standard Motor &amp; Field Supplied High Static Drive</b>										

For Standard Evaporator Fan Speed (RPM), reference Table PD-56.

Notes:

Data includes pressure drop due to standard filters and wet coils.

No accessories or options are included in pressure drop data.

Refer to Table PD-61 to determine additional static pressure drop due to other options/accessories.

Fan Motor Heat (MBH) = 2.829 x Fan BHP + .4024.

1. Field Supplied Fan Sheave AK61 required. Field Supplied Belt may be necessary.

2. Field Supplied Fan Sheave AK41 required. Field Supplied Belt may be necessary.

Factory supplied motors, in commercial equipment, are definite purpose motors, specifically designed and tested to operate reliably and continuously at all cataloged conditions. Using the full horsepower range of our fan motors as shown in our tabular data will not result in nuisance tripping or premature motor failure. Our product's warranty will not be affected.



# Performance Data

# (5 Ton) Standard Efficiency

**Table PD-29— Belt Drive Evaporator Fan Performance — 5 Ton — TSC060A3,A4,AW — Downflow Airflow**

CFM	External Static Pressure (Inches of Water)																				
	.10		.20		.30		.40		.50		.60		.70		.80		.90		1.00		
RPM	BHP	RPM	BHP	RPM	BHP	RPM	BHP	RPM	BHP	RPM	BHP	RPM	BHP	RPM	BHP	RPM	BHP	RPM	BHP	RPM	BHP
<b>1-HP Standard Motor &amp; Field Supplied Low Static Drive (1)</b>										<b>1-HP Standard Motor &amp; Drive</b>											
1600	674	0.33	735	0.39	786	0.45	835	0.50	883	0.56	928	0.63	972	0.70	1011	0.77	1048	0.84	1084	0.90	
1800	743	0.46	801	0.52	849	0.59	894	0.65	937	0.70	979	0.77	1021	0.85	1060	0.93	1098	1.01	1134	1.09	
2000	813	0.61	866	0.68	914	0.76	956	0.83	995	0.89	1035	0.96	1073	1.02	1111	1.10	1147	1.19	1183	1.28	
2200	886	0.80	933	0.87	980	0.96	1019	1.03	1057	1.11	1093	1.18	1129	1.25	1164	1.33	1198	1.40	1233	1.50	
2400	959	1.03	1000	1.10	1045	1.19	1085	1.28	1121	1.36	1154	1.45	1188	1.53	1221	1.60	—	—	—	—	

**Table PD-29 — Continued**

CFM	External Static Pressure (Inches of Water)									
	1.10		1.20		1.30		1.40		1.50	
RPM	BHP	RPM	BHP	RPM	BHP	RPM	BHP	RPM	BHP	
<b>1-HP Standard Motor &amp; Drive</b>										
1600	1117	0.97	1150	1.04	1183	1.11	1215	1.18	1244	1.25
1800	1167	1.16	1199	1.24	1230	1.31	1259	1.39	1289	1.47
2000	1216	1.37	1249	1.47	—	—	—	—	—	—
2200	—	—	—	—	—	—	—	—	—	—
2400	—	—	—	—	—	—	—	—	—	—

For Standard Evaporator Fan Speed (RPM), reference Table PD-56.

Notes:

Data includes pressure drop due to standard filters and wet coils.

No accessories or options are included in pressure drop data.

Refer to Table PD-61 to determine additional static pressure drop due to other options/accessories.

Fan Motor Heat (MBH) = 2.829 x Fan BHP + .4024.

1. Field Supplied Fan Sheave AK56 required. Field Supplied Belt may be necessary.

Factory supplied motors, in commercial equipment, are definite purpose motors, specifically designed and tested to operate reliably and continuously at all cataloged conditions. Using the full horsepower range of our fan motors as shown in our tabular data will not result in nuisance tripping or premature motor failure. Our product's warranty will not be affected.

**Table PD-30 — Belt Drive Evaporator Fan Performance — 5 Ton — TSC060A3,A4,AW — Horizontal Airflow**

CFM	External Static Pressure (Inches of Water)																				
	.10		.20		.30		.40		.50		.60		.70		.80		.90		1.00		
RPM	BHP	RPM	BHP	RPM	BHP	RPM	BHP	RPM	BHP	RPM	BHP	RPM	BHP	RPM	BHP	RPM	BHP	RPM	BHP	RPM	BHP
<b>1-HP Standard Motor &amp; Field Supplied Low Static Drive (1)</b>										<b>1-HP Standard Motor &amp; Drive</b>											
1600	746	0.39	812	0.47	876	0.54	934	0.62	985	0.70	1032	0.77	1074	0.85	1117	0.93	1157	1.01	1196	1.09	
1800	824	0.54	883	0.62	940	0.70	996	0.79	1048	0.88	1094	0.96	1137	1.05	1176	1.14	1214	1.22	1252	1.31	
2000	902	0.72	957	0.80	1008	0.90	1059	0.99	1110	1.09	1157	1.19	1200	1.28	1239	1.38	1276	1.47	1311	1.50	
2200	981	0.93	1032	1.03	1080	1.13	1126	1.23	1173	1.34	1219	1.44	—	—	—	—	—	—	—	—	
2400	1061	1.19	1109	1.29	1153	1.40	1196	1.50	—	—	—	—	—	—	—	—	—	—	—	—	

**Table PD-30 — Continued**

CFM	External Static Pressure (Inches of Water)									
	1.10		1.20		1.30		1.40		1.50	
RPM	BHP	RPM	BHP	RPM	BHP	RPM	BHP	RPM	BHP	
<b>1-HP Standard Motor &amp; Drive</b>										
1600	1232	1.18	1267	1.26	1299	1.35	1332	1.45	—	—
1800	1289	1.41	1323	1.50	—	—	—	—	—	—
2000	—	—	—	—	—	—	—	—	—	—
2200	—	—	—	—	—	—	—	—	—	—
2400	—	—	—	—	—	—	—	—	—	—

For Standard Evaporator Fan Speed (RPM), reference Table PD-56.

Notes:

Data includes pressure drop due to standard filters and wet coils.

No accessories or options are included in pressure drop data.

Refer to Table PD-61 to determine additional static pressure drop due to other options/accessories.

Fan Motor Heat (MBH) = 2.829 x Fan BHP + .4024.

1. Field Supplied Fan Sheave AK56 required. Field Supplied Belt may be necessary.

Factory supplied motors, in commercial equipment, are definite purpose motors, specifically designed and tested to operate reliably and continuously at all cataloged conditions. Using the full horsepower range of our fan motors as shown in our tabular data will not result in nuisance tripping or premature motor failure. Our product's warranty will not be affected.





# Performance Data

# (6 Ton) Standard Efficiency

**Table PD-31 — Belt Drive Evaporator Fan Performance — 6 Ton — TSC072A3,A4,AW — Downflow Airflow**

CFM	External Static Pressure (Inches of Water)																			
	.10		.20		.30		.40		.50		.60		.70		.80		.90		1.00	
	RPM	BHP	RPM	BHP	RPM	BHP	RPM	BHP	RPM	BHP	RPM	BHP	RPM	BHP	RPM	BHP	RPM	BHP	RPM	BHP
<b>1-HP Standard Motor &amp; Field Supplied Low Static Drive (1)</b>										<b>1-HP Standard Motor &amp; Drive</b>										
1920	—	—	—	—	573	0.34	630	0.41	680	0.48	726	0.55	769	0.62	811	0.70	851	0.78	889	0.87
2160	—	—	548	0.35	602	0.42	656	0.50	706	0.58	751	0.65	792	0.73	832	0.81	871	0.90	908	0.99
2400	—	—	584	0.45	635	0.52	682	0.60	732	0.69	777	0.77	818	0.86	856	0.95	893	1.04	930	1.13
2640	569	0.47	621	0.56	670	0.64	715	0.72	758	0.81	802	0.91	845	1.01	883	1.10	919	1.20	953	1.29
2880	612	0.60	660	0.69	706	0.78	749	0.86	789	0.96	830	1.06	870	1.16	909	1.27	945	1.37	979	1.48

**Table PD-31 — Continued**

CFM	External Static Pressure (Inches of Water)																			
	1.10		1.20		1.30		1.40		1.50		1.60		1.70		1.80		1.90		2.00	
	RPM	BHP	RPM	BHP	RPM	BHP	RPM	BHP	RPM	BHP	RPM	BHP	RPM	BHP	RPM	BHP	RPM	BHP	RPM	BHP
<b>1 HP Standard Motor &amp; Drive</b>						<b>1HP Standard Motor &amp; High Static Drive Kit (or 2 HP Oversized Motor &amp; Drive)</b>														
1920	925	0.95	960	1.03	994	1.11	1026	1.19	1057	1.27	1087	1.36	1116	1.44	1144	1.52	1173	1.61	1200	1.70
2160	944	1.08	978	1.17	1010	1.26	1043	1.36	1073	1.44	1104	1.54	1133	1.63	1162	1.72	1189	1.81	1216	1.91
2400	964	1.22	998	1.32	1030	1.42	1063	1.53	1092	1.63	1123	1.73	1151	1.83	1179	1.93	1206	2.03	1233	2.13
2640	986	1.39	1019	1.49	1051	1.60	1082	1.71	1112	1.81	1141	1.92	1169	2.03	1198	2.15	1225	2.26	—	—
2880	1011	1.58	1043	1.69	1073	1.79	1103	1.90	1133	2.02	1161	2.13	1190	2.26	—	—	—	—	—	—

For Standard Evaporator Fan Speed (RPM), reference Table PD-56.

Notes:

Data includes pressure drop due to standard filters and wet coils.

No accessories or options are included in pressure drop data.

Refer to Table PD-61 to determine additional static pressure drop due to other options/accessories.

1-HP Fan Motor Heat (MBH) = 2.829 x Fan BHP+.4024. 2-HP Fan Motor Heat (MBH) = 3.000 x Fan BHP+.5000

1. Field Supplied Fan Sheave AK84 and Belt AX34 required.

Factory supplied motors, in commercial equipment, are definite purpose motors, specifically designed and tested to operate reliably and continuously at all cataloged conditions. Using the full horsepower range of our fan motors as shown in our tabular data will not result in nuisance tripping or premature motor failure. Our product's warranty will not be affected.

**Table PD-32 — Belt Drive Evaporator Fan Performance — 6 Ton — TSC072A3,A4,AW — Horizontal Airflow**

CFM	External Static Pressure (Inches of Water)																			
	.10		.20		.30		.40		.50		.60		.70		.80		.90		1.00	
	RPM	BHP	RPM	BHP	RPM	BHP	RPM	BHP	RPM	BHP	RPM	BHP	RPM	BHP	RPM	BHP	RPM	BHP	RPM	BHP
<b>1-HP Standard Motor &amp; Field Supplied Low Static Drive (1)</b>										<b>1-HP Standard Motor &amp; Drive</b>										
1920	—	—	565	0.31	627	0.39	679	0.45	726	0.52	771	0.60	814	0.69	857	0.77	899	0.85	939	0.93
2160	566	0.35	609	0.41	663	0.48	716	0.57	762	0.64	804	0.72	843	0.80	883	0.90	922	0.99	960	1.08
2400	619	0.47	660	0.54	701	0.60	751	0.69	798	0.78	839	0.87	877	0.95	914	1.04	950	1.14	984	1.24
2640	672	0.61	710	0.68	745	0.76	788	0.83	833	0.93	875	1.04	914	1.13	949	1.22	984	1.31	1016	1.42
2880	726	0.77	762	0.86	795	0.94	828	1.02	869	1.11	911	1.21	950	1.33	986	1.44	1019	1.53	1051	1.63

**Table PD-32 — Continued**

**1HP Standard Motor & High Static Drive Kit (or 2 HP Oversized Motor & Drive)**

CFM	External Static Pressure (Inches of Water)																			
	1.10		1.20		1.30		1.40		1.50		1.60		1.70		1.80		1.90		2.00	
	RPM	BHP	RPM	BHP	RPM	BHP	RPM	BHP	RPM	BHP	RPM	BHP	RPM	BHP	RPM	BHP	RPM	BHP	RPM	BHP
<b>1-HP Standard Motor &amp; Drive</b>			<b>1-HP Standard Motor &amp; High Static Drive Kit (or 2 HP oversized Motor &amp; Drive)</b>																	
1920	978	1.02	1015	1.11	1051	1.20	1086	1.30	1118	1.39	1150	1.49	1180	1.58	1209	1.68	1236	1.77	1263	1.86
2160	996	1.17	1034	1.27	1069	1.36	1103	1.46	1136	1.56	1169	1.67	1199	1.77	1229	1.88	1258	1.98	—	—
2400	1020	1.35	1055	1.45	1089	1.55	1122	1.66	1154	1.76	1186	1.86	1216	1.97	1246	2.08	1276	2.20	—	—
2640	1049	1.53	1081	1.65	1113	1.76	1144	1.87	1176	1.98	1207	2.10	1237	2.21	—	—	—	—	—	—
2880	1081	1.74	1112	1.86	1141	1.97	1170	2.10	1199	2.22	—	—	—	—	—	—	—	—	—	—

**2-HP Oversized Motor & Drive**

For Standard Evaporator Fan Speed (RPM), reference Table PD-56.

Notes:

Data includes pressure drop due to standard filters and wet coils

No accessories or options are included in pressure drop data.

Refer to Table PD-61 to determine additional static pressure drop due to other options/accessories.

1-HP Fan Motor Heat (MBH) = 2.829 x Fan BHP+.4024.

2-HP Fan Motor Heat (MBH) = 3.000 x Fan BHP+.5000

1. Field Supplied Fan Sheave AK84 and Belt AX34 required.

Factory supplied motors, in commercial equipment, are definite purpose motors, specifically designed and tested to operate reliably and continuously at all cataloged conditions. Using the full horsepower range of our fan motors as shown in our tabular data will not result in nuisance tripping or premature motor failure. Our product's warranty will not be affected.



# Performance Data

# (6 Ton) Standard Efficiency

**Table PD-33 — Belt Drive Evaporator Fan Performance — 6 Ton — TSC072,AK — Downflow Airflow**

CFM	External Static Pressure (Inches of Water)																				
	.10		.20		.30		.40		.50		.60		.70		.80		.90		1.00		
RPM	BHP	RPM	BHP	RPM	BHP	RPM	BHP	RPM	BHP	RPM	BHP	RPM	BHP	RPM	BHP	RPM	BHP	RPM	BHP	RPM	BHP
<b>2-HP Standard Motor &amp; Field Supplied Low Static Drive (1)</b>										<b>2-HP Standard Motor &amp; Drive</b>											
1920	-	-	-	573	0.34	630	0.41	680	0.48	726	0.55	769	0.62	811	0.70	851	0.78	889	0.87		
2160	-	-	548	0.35	602	0.42	656	0.50	706	0.58	751	0.65	792	0.73	832	0.81	871	0.90	908	0.99	
2400	-	-	584	0.45	635	0.52	682	0.60	732	0.69	777	0.77	818	0.86	856	0.95	893	1.04	930	1.13	
2640	569	0.47	621	0.56	670	0.64	715	0.72	758	0.81	802	0.91	845	1.01	883	1.10	919	1.20	953	1.29	
2880	612	0.60	660	0.69	706	0.78	749	0.86	789	0.96	830	1.06	870	1.16	909	1.27	945	1.37	979	1.48	

**Table PD-33 — Continued**

CFM	External Static Pressure (Inches of Water)																					
	1.10		1.20		1.30		1.40		1.50		1.60		1.70		1.80		1.90		2.00			
RPM	BHP	RPM	BHP	RPM	BHP	RPM	BHP	RPM	BHP	RPM	BHP	RPM	BHP	RPM	BHP	RPM	BHP	RPM	BHP	RPM	BHP	
<b>2-HP Standard Motor &amp; Drive</b>						<b>2-HP Standard Motor &amp; High Static Drive</b>																
1920	925	0.95	960	1.03	994	1.11	1026	1.19	1057	1.27	1087	1.36	1116	1.44	1144	1.52	1173	1.61	1200	1.70		
2160	944	1.08	978	1.17	1010	1.26	1043	1.36	1073	1.44	1104	1.54	1133	1.63	1162	1.72	1189	1.81	1216	1.91		
2400	964	1.22	998	1.32	1030	1.42	1063	1.53	1092	1.63	1123	1.73	1151	1.83	1179	1.93	1206	2.03	1233	2.13		
2640	986	1.39	1019	1.49	1051	1.60	1082	1.71	1112	1.81	1141	1.92	1169	2.03	1198	2.15	1225	2.26	-	-		
2880	1011	1.58	1043	1.69	1073	1.79	1103	1.90	1133	2.02	1161	2.13	1190	2.26	-	-	-	-	-	-		

For Standard Evaporator Fan Speed (RPM), reference Table PD-56.

Notes:

Data includes pressure drop due to standard filters and wet coils.

No accessories or options are included in pressure drop data.

Refer to Table PD-61 to determine additional static pressure drop due to other options/accessories

2-HP Fan Motor Heat (MBH) = 3.000 x Fan BHP + .5000

Factory supplied motors, in commercial equipment, are definite purpose motors, specifically designed and tested to operate reliably and continuously at all cataloged conditions. Using the full horsepower range of our fan motors as shown in our tabular data will not result in nuisance tripping or premature motor failure. Our product's warranty will not be affected.

**Table PD-34 — Belt Drive Evaporator Fan Performance — 6 Ton — TSC072,AK — Horizontal Airflow**

CFM	External Static Pressure (Inches of Water)																					
	.10		.20		.30		.40		.50		.60		.70		.80		.90		1.00			
RPM	BHP	RPM	BHP	RPM	BHP	RPM	BHP	RPM	BHP	RPM	BHP	RPM	BHP	RPM	BHP	RPM	BHP	RPM	BHP	RPM	BHP	
<b>2-HP Standard Motor &amp; Field Supplied Low Static Drive (1)</b>										<b>2-HP Standard Motor &amp; Drive</b>												
1920	-	-	565	0.31	627	0.39	679	0.45	726	0.52	771	0.60	814	0.69	857	0.77	899	0.85	939	0.93		
2160	566	0.35	609	0.41	663	0.48	716	0.57	762	0.64	804	0.72	843	0.80	883	0.90	922	0.99	960	1.08		
2400	619	0.47	660	0.54	701	0.60	751	0.69	798	0.78	839	0.87	877	0.95	914	1.04	950	1.14	984	1.24		
2640	672	0.61	710	0.68	745	0.76	788	0.83	833	0.93	875	1.04	914	1.13	949	1.22	984	1.31	1016	1.42		
2880	726	0.77	762	0.86	795	0.94	828	1.02	869	1.11	911	1.21	950	1.33	986	1.44	1019	1.53	1051	1.63		

**Table PD-34 — Continued**

CFM	External Static Pressure (Inches of Water)																					
	1.10		1.20		1.30		1.40		1.50		1.60		1.70		1.80		1.90		2.00			
RPM	BHP	RPM	BHP	RPM	BHP	RPM	BHP	RPM	BHP	RPM	BHP	RPM	BHP	RPM	BHP	RPM	BHP	RPM	BHP	RPM	BHP	
<b>2-HP Standard Motor &amp; Drive</b>				<b>2-HP Standard Motor &amp; High Static Drive</b>																		
1920	978	1.02	1015	1.11	1051	1.20	1086	1.30	1118	1.39	1150	1.49	1180	1.58	1209	1.68	1236	1.77	1263	1.86		
2160	996	1.17	1034	1.27	1069	1.36	1103	1.46	1136	1.56	1169	1.67	1199	1.77	1229	1.88	1258	1.98	-	-		
2400	1020	1.35	1055	1.45	1089	1.55	1122	1.66	1154	1.76	1186	1.86	1216	1.97	1246	2.08	1276	2.20	-	-		
2640	1049	1.53	1081	1.65	1113	1.76	1144	1.87	1176	1.98	1207	2.10	1237	2.21	-	-	-	-	-	-		
2880	1081	1.74	1112	1.86	1141	1.97	1170	2.10	1199	2.22	-	-	-	-	-	-	-	-	-	-		

For Standard Evaporator Fan Speed (RPM), reference Table PD-56.

Notes:

Data includes pressure drop due to standard filters and wet coils.

No accessories or options are included in pressure drop data.

Refer to Table PD-61 to determine additional static pressure drop due to other options/accessories

2-HP Fan Motor Heat (MBH) = 3.000 x Fan BHP + .5000

Factory supplied motors, in commercial equipment, are definite purpose motors, specifically designed and tested to operate reliably and continuously at all cataloged conditions. Using the full horsepower range of our fan motors as shown in our tabular data will not result in nuisance tripping or premature motor failure. Our product's warranty will not be affected.



# Performance Data

# (7½ Ton) Standard Efficiency

**Table PD-35 – Belt Drive Evaporator Fan Performance – 7½ Ton – TSC090,092A3,A4,AW,AK – Downflow Airflow**

CFM	External Static Pressure (Inches of Water)																			
	.10		.20		.30		.40		.50		.60		.70		.80		.90		1.00	
	RPM	BHP	RPM	BHP	RPM	BHP	RPM	BHP	RPM	BHP	RPM	BHP	RPM	BHP	RPM	BHP	RPM	BHP	RPM	BHP
<b>2-HP Standard Motor &amp; Field Supplied Low Static Drive (1)</b>											<b>2-HP Standard Motor &amp; Drive</b>									
2400	—	—	—	—	652	0.54	701	0.63	750	0.72	794	0.81	834	0.90	873	0.98	909	1.08	945	1.17
2700	—	—	652	0.63	699	0.70	743	0.79	787	0.89	830	0.99	871	1.09	908	1.19	943	1.29	977	1.39
3000	656	0.71	703	0.81	747	0.91	789	0.99	827	1.10	867	1.20	906	1.31	944	1.43	980	1.54	1013	1.65
3300	713	0.93	755	1.03	797	1.15	836	1.24	873	1.34	908	1.45	944	1.57	980	1.69	1016	1.82	1050	1.94
3600	771	1.19	809	1.29	848	1.42	885	1.53	921	1.63	954	1.74	986	1.87	1019	1.99	1052	2.13	1085	2.26

**Table PD-35 – Continued**

CFM	External Static Pressure (Inches of Water)																			
	1.10		1.20		1.30		1.40		1.50		1.60		1.70		1.80		1.90		2.00	
	RPM	BHP	RPM	BHP	RPM	BHP	RPM	BHP	RPM	BHP	RPM	BHP	RPM	BHP	RPM	BHP	RPM	BHP	RPM	BHP
<b>2-HP Standard Motor &amp; Drive</b>										<b>2-HP Standard Motor &amp; High Static Drive Kit (or 3-HP Oversized Motor &amp; Drive)</b>										
2400	980	1.27	1013	1.37	1046	1.47	1076	1.57	1106	1.68	1137	1.78	1166	1.89	1194	1.99	1220	2.08	1248	2.19
2700	1010	1.49	1043	1.60	1074	1.71	1105	1.82	1134	1.93	1163	2.04	1192	2.16	1219	2.27	1246	2.39	1273	2.51
3000	1045	1.76	1076	1.87	1105	1.98	1134	2.09	1163	2.21	1192	2.34	1219	2.45	1247	2.58	1272	2.71	1299	2.84
3300	1081	2.06	1111	2.18	1141	2.30	1168	2.42	1197	2.55	1222	2.66	1249	2.79	1276	2.92	1301	3.06	1326	3.19
3600	1116	2.39	1148	2.53	1177	2.66	1204	2.79	1232	2.93	1257	3.05	1283	3.19	1309	3.32	—	—	—	—

For Standard Evaporator Fan Speed (RPM), reference Table PD-56.

Notes:

Data includes pressure drop due to standard filters and wet coils.

No accessories or options are included in pressure drop data.

Refer to Table PD-61 to determine additional static pressure drop due to other options/accessories.

2-HP Fan Motor Heat (MBH) = 2.000 x Fan BHP + .5000.

3-HP Fan Motor Heat (MBH) = 2.900 x Fan BHP + .4750.

1. Field Supplied Motor Sheave 1VL40L x 7/8 and Fan Sheave AK71 required.

Factory supplied motors, in commercial equipment, are definite purpose motors, specifically designed and tested to operate reliably and continuously at all cataloged conditions. Using the full horsepower range of our fan motors as shown in our tabular data will not result in nuisance tripping or premature motor failure. Our product's warranty will not be affected.

**Table PD-36 – Belt Drive Evaporator Fan Performance – 7½ Ton – TSC090,092A3,A4,AW,AK – Horizontal Airflow**

CFM	External Static Pressure (Inches of Water)																			
	.10		.20		.30		.40		.50		.60		.70		.80		.90		1.00	
	RPM	BHP	RPM	BHP	RPM	BHP	RPM	BHP	RPM	BHP	RPM	BHP	RPM	BHP	RPM	BHP	RPM	BHP	RPM	BHP
<b>2-HP Standard Motor &amp; Field Supplied Low Static Drive (1)</b>											<b>2-HP Standard Motor &amp; Drive</b>									
2400	—	—	673	0.56	718	0.63	769	0.72	814	0.82	855	0.90	893	0.98	929	1.08	965	1.18	999	1.29
2700	702	0.68	738	0.76	773	0.83	817	0.92	862	1.02	904	1.13	941	1.23	975	1.32	1009	1.42	1041	1.52
3000	771	0.91	805	1.00	837	1.08	870	1.17	912	1.26	951	1.38	989	1.51	1025	1.62	1056	1.72	1088	1.82
3300	842	1.19	873	1.29	903	1.38	930	1.47	963	1.57	1000	1.68	1037	1.80	1073	1.94	1106	2.08	1136	2.19
3600	913	1.53	942	1.63	970	1.74	996	1.84	1021	1.94	1052	2.04	1086	2.16	1121	2.29	1153	2.44	1184	2.59

**Table PD-36 – Continued**

CFM	External Static Pressure (Inches of Water)																			
	1.10		1.20		1.30		1.40		1.50		1.60		1.70		1.80		1.90		2.00	
	RPM	BHP	RPM	BHP	RPM	BHP	RPM	BHP	RPM	BHP	RPM	BHP	RPM	BHP	RPM	BHP	RPM	BHP	RPM	BHP
<b>2-HP Standard Motor &amp; Drive</b>										<b>2-HP Standard Motor &amp; High Static Drive Kit (or 3-HP Oversized Motor &amp; Drive)</b>										
2400	1035	1.39	1070	1.50	1104	1.60	1137	1.70	1168	1.81	1201	1.92	1232	2.03	1261	2.14	1291	2.26	1319	2.38
2700	1073	1.64	1104	1.76	1136	1.87	1167	1.99	1198	2.11	1228	2.22	1258	2.34	1287	2.46	1315	2.58	1343	2.69
3000	1117	1.93	1146	2.05	1176	2.17	1205	2.31	1233	2.44	1261	2.56	1289	2.69	1317	2.82	1344	2.95	1372	3.08
3300	1165	2.30	1194	2.41	1220	2.52	1248	2.66	1275	2.79	1301	2.93	1326	3.07	1352	3.22	1378	3.36	—	—
3600	1215	2.73	1242	2.86	1269	2.98	1295	3.10	1319	3.22	1345	3.35	—	—	—	—	—	—	—	—

For Standard Evaporator Fan Speed (RPM), reference Table PD-56.

Notes:

Data includes pressure drop due to standard filters and wet coils.

No accessories or options are included in pressure drop data.

Refer to Table PD-61 to determine additional static pressure drop due to other options/accessories.

2-HP Fan Motor Heat (MBH) = 2.000 x Fan BHP + .5000.

3-HP Fan Motor Heat (MBH) = 2.900 x Fan BHP + .4750.

1. Field Supplied Motor Sheave 1VL40L x 7/8 and Fan Sheave AK71 required.

Factory supplied motors, in commercial equipment, are definite purpose motors, specifically designed and tested to operate reliably and continuously at all cataloged conditions. Using the full horsepower range of our fan motors as shown in our tabular data will not result in nuisance tripping or premature motor failure. Our product's warranty will not be affected.



# Performance Data

# (8½ Ton) Standard Efficiency

**Table PD-37— Belt Drive Evaporator Fan Performance — 8½ Ton — TSC102A3,A4,AW, AK — Downflow Airflow**

CFM	External Static Pressure (Inches of Water)																				
	.10		.20		.30		.40		.50		.60		.70		.80		.90		1.00		
RPM	BHP	RPM	BHP	RPM	BHP	RPM	BHP	RPM	BHP	RPM	BHP	RPM	BHP	RPM	BHP	RPM	BHP	RPM	BHP	RPM	BHP
<b>2-HP Standard Motor &amp; Field Supplied Low Static Drive (1)</b>											<b>2-HP Standard Motor &amp; Drive</b>										
2720	—	—	—	—	—	—	—	613	0.60	655	0.72	695	0.84	733	0.95	769	1.08	802	1.21	833	1.34
3060	—	—	—	—	—	611	0.64	650	0.74	688	0.85	725	0.98	761	1.11	796	1.25	828	1.38	861	1.52
3400	—	—	612	0.68	651	0.79	689	0.91	724	1.02	759	1.15	792	1.29	825	1.43	856	1.58	887	1.72	
3740	622	0.76	659	0.86	693	0.97	729	1.10	764	1.23	795	1.35	826	1.49	857	1.64	887	1.79	916	1.96	
4080	671	0.96	706	1.08	738	1.19	770	1.32	804	1.46	834	1.60	864	1.74	892	1.88	920	2.04	948	2.20	

**Table PD-37 — Continued**

CFM	External Static Pressure (Inches of Water)																				
	1.10		1.20		1.30		1.40		1.50		1.60		1.70		1.80		1.90		2.00		
RPM	BHP	RPM	BHP	RPM	BHP	RPM	BHP	RPM	BHP	RPM	BHP	RPM	BHP	RPM	BHP	RPM	BHP	RPM	BHP	RPM	BHP
<b>2-HP Standard Motor &amp; Drive</b>											<b>3-HP Oversized Motor &amp; Drive</b>										
2720	863	1.48	892	1.63	920	1.78	946	1.93	973	2.08	999	2.24	1025	2.39	1050	2.55	1073	2.71	1098	2.88	
3060	891	1.66	919	1.81	946	1.96	973	2.12	999	2.29	1024	2.46	1048	2.63	1072	2.80	1096	2.98	1119	3.14	
3400	917	1.87	946	2.03	974	2.18	1001	2.34	1026	2.52	1051	2.69	1074	2.86	1099	3.05	1121	3.23	1143	3.41	
3740	945	2.11	974	2.28	1001	2.44	1028	2.61	1054	2.78	1079	2.96	1103	3.14	1126	3.32	—	—	—	—	
4080	976	2.38	1002	2.56	1029	2.73	1055	2.91	1081	3.09	1105	3.26	1130	3.45	—	—	—	—	—	—	

For Standard Evaporator Fan Speed (RPM), reference Table PD-56.

Notes:

Data includes pressure drop due to standard filters and wet coils.

No accessories or options are included in pressure drop data.

Refer to Table PD-61 to determine additional static pressure drop due to other options/accessories

2-HP Fan Motor Heat (MBH) = 2.000 x Fan BHP + .5000.

3-HP Fan Motor Heat (MBH) = 2.900 x Fan BHP + .4750.

1. Field Supplied Fan Sheave AK79 and Belt AX38 required.

Factory supplied motors, in commercial equipment, are definite purpose motors, specifically designed and tested to operate reliably and continuously at all cataloged conditions. Using the full horsepower range of our fan motors as shown in our tabular data will not result in nuisance tripping or premature motor failure. Our product's warranty will not be affected.

**Table PD-38 — Belt Drive Evaporator Fan Performance — 8½ Ton — TSC102A3,A4,AW, AK — Horizontal Airflow**

CFM	External Static Pressure (Inches of Water)																				
	.10		.20		.30		.40		.50		.60		.70		.80		.90		1.00		
RPM	BHP	RPM	BHP	RPM	BHP	RPM	BHP	RPM	BHP	RPM	BHP	RPM	BHP	RPM	BHP	RPM	BHP	RPM	BHP	RPM	BHP
<b>2-HP Standard Motor &amp; Field Supplied Low Static Drive (1)</b>											<b>2-HP Standard Motor &amp; Drive</b>										
2720	—	—	598	0.57	646	0.67	689	0.78	734	0.90	781	1.04	826	1.18	865	1.31	898	1.44	928	1.56	
3060	616	0.69	654	0.77	693	0.86	735	0.98	773	1.10	812	1.23	855	1.39	897	1.55	934	1.70	969	1.85	
3400	675	0.92	711	1.01	743	1.10	781	1.22	819	1.36	853	1.49	886	1.62	925	1.79	964	1.97	1000	2.14	
3740	735	1.20	770	1.30	799	1.40	830	1.51	865	1.65	899	1.79	930	1.94	960	2.09	994	2.26	1028	2.44	
4080	796	1.53	828	1.65	857	1.76	883	1.86	913	1.99	945	2.15	977	2.30	1006	2.47	1034	2.63	1061	2.79	
											<b>3-HP Oversized Motor &amp; Drive</b>										

**Table PD-38 — Continued**

CFM	External Static Pressure (Inches of Water)																				
	1.10		1.20		1.30		1.40		1.50		1.60		1.70		1.80		1.90		2.00		
RPM	BHP	RPM	BHP	RPM	BHP	RPM	BHP	RPM	BHP	RPM	BHP	RPM	BHP	RPM	BHP	RPM	BHP	RPM	BHP	RPM	BHP
<b>2-HP Standard Motor &amp; Drive</b>											<b>3-HP Oversized Motor &amp; Drive</b>										
2720	956	1.67	982	1.79	1008	1.91	1033	2.03	1056	2.14	1079	2.26	1102	2.38	1125	2.50	1146	2.62	1168	2.74	
3060	999	1.99	1026	2.12	1052	2.26	1078	2.39	1101	2.52	1124	2.66	1146	2.79	1168	2.92	1188	3.05	1209	3.18	
3400	1034	2.32	1067	2.49	1094	2.64	1120	2.79	1145	2.94	1168	3.09	1191	3.24	1213	3.39	—	—	—	—	
3740	1063	2.63	1098	2.84	1129	3.03	1158	3.21	1185	3.39	—	—	—	—	—	—	—	—	—	—	
4080	1093	2.99	1125	3.19	1157	3.40	—	—	—	—	—	—	—	—	—	—	—	—	—	—	

For Standard Evaporator Fan Speed (RPM), reference Table PD-56.

Notes:

Data includes pressure drop due to standard filters and wet coils.

No accessories or options are included in pressure drop data.

Refer to Table PD-61 to determine additional static pressure drop due to other options/accessories

2-HP Fan Motor Heat (MBH) = 2.000 x Fan BHP + .5000.

3-HP Fan Motor Heat (MBH) = 2.900 x Fan BHP + .4750.

1. Field Supplied Fan Sheave AK79 and Belt AX38 required.

Factory supplied motors, in commercial equipment, are definite purpose motors, specifically designed and tested to operate reliably and continuously at all cataloged conditions. Using the full horsepower range of our fan motors as shown in our tabular data will not result in nuisance tripping or premature motor failure. Our product's warranty will not be affected.



# Performance Data

# (10 Ton) Standard Efficiency

**Table PD-39 – Belt Drive Evaporator Fan Performance – 10 Ton – TSC120A3,A4,AW,AK – Downflow Airflow**

CFM	External Static Pressure (Inches of Water)																			
	.10		.20		.30		.40		.50		.60		.70		.80		.90		1.00	
	RPM	BHP	RPM	BHP	RPM	BHP	RPM	BHP	RPM	BHP	RPM	BHP	RPM	BHP	RPM	BHP	RPM	BHP	RPM	BHP
<b>3-HP Standard Motor &amp; Field Supplied Low Static Drive (1)</b>																				
3200	—	—	—	—	—	—	—	—	718	0.97	754	1.10	789	1.25	822	1.38	856	1.53	887	1.67
3600	—	—	—	—	—	—	731	1.08	764	1.20	797	1.33	829	1.48	860	1.63	892	1.79	922	1.95
4000	—	—	715	1.09	747	1.21	782	1.35	814	1.49	844	1.63	874	1.77	903	1.93	932	2.09	960	2.27
4400	741	1.27	773	1.40	803	1.53	834	1.67	864	1.82	894	1.98	922	2.13	948	2.28	975	2.44	1001	2.62
4800	803	1.62	833	1.76	861	1.90	887	2.04	916	2.20	945	2.38	972	2.55	997	2.71	1022	2.87	1046	3.04
<b>3-HP Standard Motor &amp; Drive</b>																				

**Table PD-39 – Continued**

CFM	External Static Pressure (Inches of Water)																			
	1.10		1.20		1.30		1.40		1.50		1.60		1.70		1.80		1.90		2.00	
	RPM	BHP	RPM	BHP	RPM	BHP	RPM	BHP	RPM	BHP	RPM	BHP	RPM	BHP	RPM	BHP	RPM	BHP	RPM	BHP
<b>3-HP Standard Motor &amp; Drive</b>																				
3200	917	1.82	945	1.97	973	2.14	999	2.30	1024	2.47	1048	2.65	1072	2.82	1095	3.00	1117	3.17	1140	3.36
3600	951	2.11	979	2.27	1007	2.43	1033	2.60	1059	2.78	1082	2.95	1107	3.14	1130	3.33	1152	3.52	1173	3.71
4000	988	2.44	1015	2.62	1042	2.79	1068	2.97	1093	3.15	1117	3.33	1142	3.52	1164	3.70	1187	3.91	1209	4.11
4400	1028	2.81	1053	3.00	1078	3.19	1103	3.38	1128	3.57	1152	3.77	1176	3.96	1198	4.15	1221	4.36	1243	4.56
4800	1071	3.23	1095	3.42	1119	3.62	1142	3.83	1166	4.04	1189	4.25	1212	4.46	1233	4.66	1256	4.88	1277	5.09
<b>5-HP Oversized Motor &amp; Drive</b>																				

For Standard Evaporator Fan Speed (RPM), reference Table PD-56.

Notes:

Data includes pressure drop due to standard filters and wet coils.

No accessories or options are included in pressure drop data.

Refer to Table PD-61 to determine additional static pressure drop due to other options/accessories

3-HP Fan Motor Heat (MBH) = 2.900 x Fan BHP+.475. 5-HP Fan Motor Heat (MBH) = 2.950 x Fan BHP+.470.

1. Field Supplied Motor Sheave 1VM50 x 7/8", Fan Sheave AK89 and Belt AX40 required.

Factory supplied motors, in commercial equipment, are definite purpose motors, specifically designed and tested to operate reliably and continuously at all cataloged conditions. Using the full horsepower range of our fan motors as shown in our tabular data will not result in nuisance tripping or premature motor failure. Our product's warranty will not be affected.

**Table PD-40— Belt Drive Evaporator Fan Performance – 10 Ton – TSC120A3,A4,AW,AK – Horizontal Airflow**

CFM	External Static Pressure (Inches of Water)																			
	.10		.20		.30		.40		.50		.60		.70		.80		.90		1.00	
	RPM	BHP	RPM	BHP	RPM	BHP	RPM	BHP	RPM	BHP	RPM	BHP	RPM	BHP	RPM	BHP	RPM	BHP	RPM	BHP
<b>3-HP Standard Motor &amp; Field Supplied Low Static Drive (1)</b>																				
3200	—	—	—	—	730	1.00	771	1.13	807	1.26	844	1.39	886	1.55	926	1.72	965	1.89	1000	2.06
3600	729	1.13	761	1.22	792	1.32	829	1.45	865	1.60	898	1.74	930	1.89	965	2.06	1002	2.24	1038	2.43
4000	802	1.52	831	1.63	860	1.73	890	1.86	923	2.01	956	2.17	986	2.32	1015	2.48	1044	2.65	1077	2.85
4400	876	1.99	905	2.12	931	2.24	955	2.35	983	2.49	1014	2.66	1045	2.84	1072	3.01	1098	3.18	1125	3.36
4800	950	2.56	977	2.70	1002	2.84	1025	2.96	1048	3.08	1074	3.24	1102	3.43	1131	3.63	1156	3.81	1181	4.00
<b>3-HP Standard Motor &amp; Drive</b>																				
<b>5-HP Oversized Motor &amp; Drive</b>																				

**Table PD-40 – Continued**

CFM	External Static Pressure (Inches of Water)																			
	1.10		1.20		1.30		1.40		1.50		1.60		1.70		1.80		1.90		2.00	
	RPM	BHP	RPM	BHP	RPM	BHP	RPM	BHP	RPM	BHP	RPM	BHP	RPM	BHP	RPM	BHP	RPM	BHP	RPM	BHP
<b>3-HP Standard Motor &amp; Drive</b>																				
3200	1029	2.20	1057	2.35	1084	2.49	1108	2.63	1132	2.77	1155	2.91	1177	3.05	1198	3.18	1219	3.32	1239	3.46
3600	1072	2.62	1106	2.81	1134	2.98	1160	3.15	1185	3.31	1209	3.47	1231	3.63	1252	3.78	1274	3.94	1295	4.10
4000	1111	3.05	1143	3.26	1174	3.47	1204	3.68	1232	3.88	1260	4.09	1283	4.27	1306	4.46	1327	4.63	1349	4.81
4400	1152	3.55	1182	3.76	1211	3.99	1241	4.21	1270	4.44	1299	4.68	1327	4.91	1352	5.14	1377	5.37	1400	5.57
4800	1205	4.19	1229	4.39	1253	4.58	1280	4.81	1309	5.06	1336	5.31	1363	5.56	—	—	—	—	—	—
<b>5-HP Oversized Motor &amp; Drive</b>																				

For Standard Evaporator Fan Speed (RPM), reference Table PD-56.

Notes:

Data includes pressure drop due to standard filters and wet coils.

No accessories or options are included in pressure drop data.

Refer to Table PD-61 to determine additional static pressure drop due to other options/accessories

3-HP Fan Motor Heat (MBH) = 2.900 x Fan BHP+.475. 5-HP Fan Motor Heat (MBH) = 2.950 x Fan BHP+.470.

1. Field Supplied Motor Sheave 1VM50 x 7/8", Fan Sheave AK89 and Belt AX40 required.

Factory supplied motors, in commercial equipment, are definite purpose motors, specifically designed and tested to operate reliably and continuously at all cataloged conditions. Using the full horsepower range of our fan motors as shown in our tabular data will not result in nuisance tripping or premature motor failure. Our product's warranty will not be affected.



# Performance Data

## (3, 4, 5 Ton) High Efficiency

**Table PD-41— Direct Drive Evaporator Fan Performance — 3, 4, and 5 Ton — THC036A, THC048A, THC060A**

		External Static Pressure (Inches of Water) & Motor Power (Bhp) <sup>1</sup>								
Unit Tons	Model No.	CFM	Standard Motor				Oversized Motor			
			High Speed		Low Speed		High Speed		Low Speed	
			ESP	BHP	ESP	BHP	ESP	BHP	ESP	BHP
3	THC036A Horizontal	960	0.74	0.36	0.56	0.28	0.89	0.38	0.82	0.35
		1020	0.69	0.37	0.49	0.28	0.85	0.39	0.77	0.36
		1080	0.65	0.38	0.44	0.29	0.82	0.41	0.74	0.38
		1140	0.61	0.39	0.37	0.29	0.77	0.43	0.69	0.40
		1200	0.55	0.40	0.29	0.30	0.74	0.44	0.65	0.41
		1260	0.51	0.41	0.19	0.30	0.70	0.45	0.61	0.42
		1320	0.46	0.42	0.10	0.31	0.67	0.47	0.57	0.44
		1380	0.41	0.43	0.00	0.31	0.64	0.48	0.52	0.45
		1440	0.34	0.44	—	—	0.57	0.51	0.45	0.48
		4	THC048A Horizontal	1280	0.90	0.53	0.79	0.47	1.16	0.67
1360	0.83			0.54	0.71	0.47	1.11	0.68	0.90	0.58
1440	0.76			0.54	0.65	0.48	1.06	0.70	0.85	0.60
1520	0.69			0.55	0.56	0.48	1.01	0.73	0.77	0.63
1600	0.60			0.55	0.44	0.49	0.94	0.75	0.68	0.64
1680	0.51			0.56	0.32	0.49	0.89	0.78	0.59	0.66
1760	0.42			0.56	0.17	0.50	0.84	0.82	0.42	0.68
1840	0.31			0.57	0.05	0.50	0.75	0.83	0.29	0.70
1920	0.21			0.57	—	—	0.67	0.85	0.18	0.73
5	THC060A Horizontal			1600	1.04	0.78	0.94	0.64	1.37	0.90
		1700	0.97	0.80	0.81	0.65	1.29	0.94	1.13	0.89
		1800	0.92	0.85	0.70	0.65	1.21	0.98	1.02	0.91
		1900	0.82	0.88	0.61	0.65	1.20	1.02	0.92	0.94
		2000	0.74	0.90	0.45	0.66	1.03	1.05	0.81	0.95
		2100	0.64	0.93	0.30	0.66	0.94	1.10	0.68	0.96
		2200	0.51	0.94	0.15	0.67	0.83	1.12	0.47	0.96
		2300	0.42	0.95	—	—	0.73	1.17	0.23	0.97
		2400	0.31	0.97	—	—	0.60	1.20	—	—
		3	THC036A Downflow	960	0.79	0.36	0.56	0.28	0.94	0.38
1020	0.74			0.37	0.54	0.28	0.90	0.39	0.82	0.36
1080	0.70			0.38	0.49	0.29	0.87	0.41	0.79	0.38
1140	0.66			0.39	0.42	0.29	0.82	0.43	0.74	0.40
1200	0.60			0.40	0.34	0.30	0.79	0.44	0.70	0.41
1260	0.56			0.41	0.24	0.30	0.75	0.45	0.66	0.42
1320	0.51			0.42	0.15	0.31	0.72	0.47	0.62	0.44
1380	0.46			0.43	0.05	0.31	0.69	0.48	0.57	0.45
1440	0.39			0.44	—	—	0.62	0.51	0.50	0.48
4	THC048A Downflow			1280	0.95	0.53	0.84	0.47	1.21	0.67
		1360	0.88	0.54	0.76	0.47	1.16	0.68	0.95	0.58
		1440	0.81	0.54	0.70	0.48	1.11	0.70	0.90	0.60
		1520	0.74	0.55	0.61	0.48	1.06	0.73	0.82	0.63
		1600	0.65	0.55	0.49	0.49	0.99	0.75	0.73	0.64
		1680	0.56	0.56	0.37	0.49	0.94	0.78	0.64	0.66
		1760	0.47	0.56	0.22	0.50	0.89	0.82	0.47	0.68
		1840	0.36	0.57	0.10	0.50	0.80	0.83	0.34	0.70
		1920	0.26	0.57	—	—	0.72	0.85	—	—
		5	THC060A Downflow	1600	1.09	0.78	0.99	0.64	1.42	0.90
1700	1.02			0.80	0.86	0.65	1.34	0.94	1.18	0.89
1800	0.97			0.85	0.75	0.65	1.26	0.98	1.07	0.91
1900	0.87			0.88	0.66	0.65	1.25	1.02	0.97	0.94
2000	0.79			0.90	0.50	0.66	1.08	1.05	0.86	0.95
2100	0.69			0.93	0.35	0.66	0.99	1.10	0.73	0.96
2200	0.56			0.94	0.20	0.67	0.88	1.12	0.52	0.96
2300	0.47			0.95	—	—	0.78	1.17	0.28	0.97
2400	0.36			0.97	—	—	0.65	1.20	—	—

Fan motor heat (MBH) = 3.72 x Fan Bhp + .24.

Factory supplied motors, in commercial equipment, are definite purpose motors, specifically designed and tested to operate reliably and continuously at all cataloged conditions. Using the full horsepower range of our fan motors as shown in our tabular data will not result in nuisance tripping or premature motor failure. Our product's warranty will not be affected.

Notes:

1. Data includes pressure drop due to wet coil and filters.
2. 5 ton oversized motor performance is with 12 x 11 FC blower wheel.



# Performance Data

## (3 Ton) High Efficiency

**Table PD-42 — Belt Drive Evaporator Fan Performance — 3 Ton — THC036A3,A4,AW — Downflow Airflow**

CFM	External Static Pressure (Inches of Water)																			
	.10		.20		.30		.40		.50		.60		.70		.80		.90		1.00	
	RPM	BHP	RPM	BHP	RPM	BHP	RPM	BHP	RPM	BHP	RPM	BHP	RPM	BHP	RPM	BHP	RPM	BHP	RPM	BHP
<b>1-HP Standard Motor &amp; Low Static Drive Accessory Kit (1)</b>											<b>1-HP Standard Motor &amp; Drive</b>									
600*	—	—	449	0.06	525	0.09	593	0.12	653	0.16	707	0.20	757	0.23	802	0.27	845	0.31	885	0.36
720*	—	—	475	0.08	547	0.11	612	0.14	669	0.18	724	0.22	774	0.26	821	0.31	864	0.35	905	0.40
840*	—	—	501	0.10	572	0.13	634	0.17	690	0.21	742	0.25	791	0.29	837	0.34	881	0.39	922	0.44
960	—	—	528	0.12	599	0.16	658	0.20	713	0.24	763	0.29	810	0.33	855	0.38	898	0.43	939	0.49
1080	—	—	557	0.15	625	0.19	685	0.24	738	0.28	786	0.33	832	0.38	876	0.43	917	0.48	957	0.54
1200	—	—	588	0.19	652	0.23	712	0.28	764	0.33	811	0.38	856	0.43	898	0.48	939	0.54	978	0.59
1320	552	0.18	622	0.23	681	0.27	738	0.32	790	0.38	838	0.44	882	0.49	923	0.55	962	0.60	1000	0.66
1440	588	0.23	657	0.28	713	0.33	765	0.37	817	0.43	865	0.50	909	0.56	949	0.62	987	0.68	1024	0.74

**Table PD-42 — Continued**

CFM	External Static Pressure (Inches of Water)									
	1.10		1.20		1.30		1.40		1.50	
	RPM	BHP	RPM	BHP	RPM	BHP	RPM	BHP	RPM	BHP
<b>1-HP Standard Motor &amp; Drive</b>										
600*	924	0.40	962	0.45	997	0.49	1031	0.54	1065	0.59
720*	943	0.45	980	0.50	1016	0.55	1050	0.60	1082	0.65
840*	962	0.50	999	0.55	1034	0.60	1068	0.66	1103	0.71
960	978	0.54	1016	0.60	1052	0.66	1086	0.72	1120	0.78
1080	995	0.59	1033	0.65	1069	0.71	1103	0.78	1136	0.84
1200	1015	0.65	1051	0.71	1086	0.77	1120	0.84	1154	0.91
1320	1036	0.72	1072	0.78	1106	0.85	1138	0.91	1171	0.98
1440	1060	0.80	1094	0.86	1128	0.93	1160	1.00	1192	1.07

**1-HP Standard Motor & Field Supplied High Static Drive (2)**

For Standard Evaporator Fan Speed (RPM), reference Table PD-56.  
Table includes Dehumidification (Hot Gas Reheat Option).

**\*Unit applications below 960 CFM**

- Electric heaters restricted on applications below 960 CFM.
- Dehumidification (Hot Gas Reheat) or TXV with Froststat and Crankcase Heaters are required on applications below 960 CFM.

Notes:

Data includes pressure drop due to standard filters and wet coils.  
No accessories or options are included in pressure drop data.  
Data does not include pressure drop due to reheat coil.

Refer to Table PD-61 to determine additional static pressure drop due to other options/accessories

1-HP Fan Motor Heat (MBH) = 2.829 x Fan BHP + .4024.

1. BAYLSDR006A Required.

2. Field Supplied Fan Sheave AK41 required. Field Supplied Belt may be necessary.

Factory supplied motors, in commercial equipment, are definite purpose motors, specifically designed and tested to operate reliably and continuously at all cataloged conditions. Using the full horsepower range of our fan motors as shown in our tabular data will not result in nuisance tripping or premature motor failure. Our product's warranty will not be affected.

**Table PD-43— Belt Drive Evaporator Fan Performance — 3 Ton — THC036A3,A4,AW — Horizontal Airflow**

CFM	External Static Pressure (Inches of Water)																			
	.10		.20		.30		.40		.50		.60		.70		.80		.90		1.00	
	RPM	BHP	RPM	BHP	RPM	BHP	RPM	BHP	RPM	BHP	RPM	BHP	RPM	BHP	RPM	BHP	RPM	BHP	RPM	BHP
<b>1-HP Standard Motor &amp; Low Static Drive Accessory Kit (1)</b>											<b>1-HP Standard Motor &amp; Drive</b>									
600*	—	—	493	0.07	567	0.11	628	0.14	683	0.18	737	0.22	786	0.26	832	0.30	876	0.35	918	0.40
720*	427	0.06	523	0.09	599	0.13	662	0.17	716	0.21	766	0.25	811	0.29	856	0.34	899	0.39	940	0.44
840*	460	0.08	555	0.12	631	0.16	694	0.21	750	0.25	799	0.30	844	0.35	886	0.39	925	0.44	965	0.49
960	493	0.10	588	0.15	661	0.19	725	0.24	782	0.29	832	0.35	878	0.40	919	0.46	958	0.51	996	0.56
1080	531	0.13	622	0.18	694	0.24	756	0.29	813	0.34	864	0.40	910	0.46	954	0.52	993	0.59	1031	0.65
1200	570	0.17	654	0.23	727	0.28	787	0.34	843	0.40	895	0.46	942	0.52	986	0.59	1026	0.66	1064	0.73
1320	610	0.22	687	0.28	760	0.34	821	0.40	875	0.46	925	0.53	973	0.59	1017	0.66	1058	0.73	1095	0.81
1440	651	0.27	723	0.33	793	0.40	855	0.47	908	0.53	956	0.60	1003	0.67	1047	0.75	1088	0.82	1127	0.89

**1-HP Standard Motor & Field Supplied High Static Drive (2)**

**Table PD-43— Continued**

CFM	External Static Pressure (Inches of Water)									
	1.10		1.20		1.30		1.40		1.50	
	RPM	BHP	RPM	BHP	RPM	BHP	RPM	BHP	RPM	BHP
<b>1-HP Standard Motor &amp; Drive</b>										
600*	958	0.45	996	0.50	1032	0.55	1068	0.60	1102	0.66
720*	978	0.49	1016	0.55	1053	0.61	1087	0.66	1121	0.72
840*	1002	0.55	1039	0.60	1076	0.67	1109	0.72	1143	0.79
960	1032	0.62	1066	0.67	1101	0.73	1133	0.79	1166	0.86
1080	1065	0.70	1099	0.76	1132	0.82	1164	0.89	1194	0.95
1200	1099	0.80	1133	0.86	1166	0.93	1197	0.99	1227	1.06
1320	1132	0.88	1167	0.96	1200	1.04	1230	1.11	1261	1.19
1440	1164	0.97	1199	1.05	1232	1.14	1263	1.22	1294	1.30

**1-HP Standard Motor & Field Supplied High Static Drive (2)**

For Standard Evaporator Fan Speed (RPM), reference Table PD-56.  
Table includes Dehumidification (Hot Gas Reheat Option).

**\*Unit applications below 960 CFM**

- Electric heaters restricted on applications below 960 CFM.
- Dehumidification (Hot Gas Reheat) or TXV with Froststat and Crankcase Heaters are required on applications below 960 CFM.

Notes:

Data includes pressure drop due to standard filters and wet coils.  
Data does not include pressure drop due to reheat coil.

No accessories or options are included in pressure drop data.

Refer to Table PD-61 to determine additional static pressure drop due to other options/accessories

1 HP Fan Motor Heat (MBH) = 2.829 x Fan BHP + .4024.

1. BAYLSDR006A Required.

2. Field Supplied Fan Sheave AK41 required. Field Supplied Belt may be necessary.

Factory supplied motors, in commercial equipment, are definite purpose motors, specifically designed and tested to operate reliably and continuously at all cataloged conditions. Using the full horsepower range of our fan motors as shown in our tabular data will not result in nuisance tripping or premature motor failure. Our product's warranty will not be affected.



# Performance Data

# (4 Ton) High Efficiency

**Table PD-44 – Belt Drive Evaporator Fan Performance – 4 Ton – THC048A3,A4,AW – Downflow Airflow**

CFM	External Static Pressure (Inches of Water)																			
	.10		.20		.30		.40		.50		.60		.70		.80		.90		1.00	
	RPM	BHP	RPM	BHP	RPM	BHP	RPM	BHP	RPM	BHP	RPM	BHP	RPM	BHP	RPM	BHP	RPM	BHP	RPM	BHP
<b>1-HP Standard Motor &amp; Low Static Drive Accessory Kit (1)</b>											<b>1-HP Standard Motor &amp; Drive</b>									
800*	—	—	501	0.09	571	0.13	633	0.16	690	0.20	742	0.25	792	0.29	838	0.34	882	0.39	923	0.44
960*	459	0.09	539	0.13	609	0.17	668	0.21	721	0.25	771	0.29	819	0.34	864	0.39	906	0.44	947	0.50
1120*	509	0.13	580	0.17	646	0.21	706	0.26	758	0.31	805	0.36	850	0.41	893	0.46	934	0.51	973	0.57
1280	559	0.18	626	0.23	686	0.27	744	0.32	796	0.38	843	0.43	885	0.49	927	0.54	967	0.60	1005	0.66
1440	609	0.24	674	0.30	730	0.34	783	0.39	834	0.45	882	0.52	924	0.58	964	0.64	1002	0.70	1038	0.76
1600	661	0.32	724	0.38	776	0.44	825	0.49	872	0.54	919	0.61	962	0.68	1002	0.75	1039	0.82	1076	0.89
1760	716	0.42	775	0.48	825	0.54	870	0.60	915	0.66	958	0.72	999	0.79	1040	0.87	1078	0.95	1113	1.03
1920	771	0.53	825	0.59	875	0.66	918	0.73	959	0.79	1000	0.86	1039	0.92	1078	1.00	1116	1.09	1151	1.17

**Table PD-44 – Continued**

CFM	External Static Pressure (Inches of Water)									
	1.10		1.20		1.30		1.40		1.50	
	RPM	BHP	RPM	BHP	RPM	BHP	RPM	BHP	RPM	BHP
<b>1-HP Standard Motor &amp; Drive</b>										
800*	963	0.49	999	0.54	1034	0.59	1068	0.65	1101	0.70
960*	986	0.55	1023	0.61	1060	0.67	1095	0.73	1127	0.79
1120*	1012	0.63	1048	0.69	1084	0.75	1118	0.81	1151	0.88
1280	1041	0.72	1076	0.78	1110	0.84	1143	0.91	1176	0.98
1440	1074	0.83	1108	0.89	1141	0.96	1174	1.03	1205	1.10
1600	1109	0.95	1142	1.02	1175	1.09	1207	1.17	1236	1.24
1760	1147	1.10	1179	1.17	1211	1.25	1241	1.32	—	—
1920	1186	1.26	1218	1.34	1249	1.42	—	—	—	—

For Standard Evaporator Fan Speed (RPM), reference Table PD-56. Table includes Dehumidification (Hot Gas Reheat Option).

**\*Unit applications below 1280 CFM**

- Electric heaters restricted on applications below 1280 CFM.
- Dehumidification (Hot Gas Reheat) or TXV with Frost and Crankcase Heaters are required on applications below 1280 CFM.

**Notes:**

Data includes pressure drop due to standard filters and wet coils. Data does not include pressure drop due to reheat coil.

No accessories or options are included in pressure drop data.

Refer to Table PD-61 to determine additional static pressure drop due to other options/accessories

1 HP Fan Motor Heat (MBH) = 2.829 x Fan BHP + .4024.

1. BAYLSDR007A Required.

Factory supplied motors, in commercial equipment, are definite purpose motors, specifically designed and tested to operate reliably and continuously at all cataloged conditions. Using the full horsepower range of our fan motors as shown in our tabular data will not result in nuisance tripping or premature motor failure. Our product's warranty will not be affected.

**Table PD-45 – Belt Drive Evaporator Fan Performance – 4 Ton – THC048A3,A4,AW – Horizontal Airflow**

CFM	External Static Pressure (Inches of Water)																			
	.10		.20		.30		.40		.50		.60		.70		.80		.90		1.00	
	RPM	BHP	RPM	BHP	RPM	BHP	RPM	BHP	RPM	BHP	RPM	BHP	RPM	BHP	RPM	BHP	RPM	BHP	RPM	BHP
<b>1-HP Standard Motor &amp; Low Static Drive Accessory Kit (1)</b>											<b>1-HP Standard Motor &amp; Drive</b>									
800*	461	0.08	553	0.11	629	0.16	692	0.20	745	0.25	794	0.29	838	0.34	881	0.38	922	0.43	962	0.48
960*	509	0.11	600	0.16	672	0.20	736	0.25	791	0.30	841	0.36	887	0.42	927	0.47	966	0.52	1004	0.58
1120*	561	0.16	649	0.21	719	0.26	779	0.32	836	0.37	886	0.43	932	0.50	975	0.56	1014	0.63	1052	0.69
1280	617	0.21	696	0.27	767	0.34	826	0.40	879	0.46	930	0.52	976	0.59	1020	0.66	1060	0.73	1098	0.80
1440	674	0.29	745	0.35	815	0.42	874	0.49	925	0.56	974	0.63	1020	0.70	1064	0.77	1104	0.85	1142	0.92
1600	733	0.38	799	0.45	862	0.53	922	0.60	975	0.68	1020	0.75	1065	0.83	1107	0.91	1147	0.99	1186	1.07
1760	793	0.49	854	0.56	911	0.65	969	0.73	1023	0.82	1069	0.90	1112	0.98	1152	1.07	1191	1.15	1230	1.24
1920	853	0.62	911	0.70	964	0.79	1018	0.88	1069	0.97	1118	1.06	1161	1.15	1201	1.25	1239	1.34	1275	1.43

**Table PD-45 – Continued**

CFM	External Static Pressure (Inches of Water)									
	1.10		1.20		1.30		1.40		1.50	
	RPM	BHP	RPM	BHP	RPM	BHP	RPM	BHP	RPM	BHP
<b>1-HP Standard Motor</b>										
800*	1001	0.54	1038	0.60	1072	0.65	1108	0.71	1142	0.78
960*	1040	0.63	1073	0.68	1108	0.75	1141	0.81	1175	0.88
1120*	1087	0.75	1119	0.81	1152	0.88	1183	0.94	1213	1.00
1280	1132	0.88	1167	0.95	1199	1.03	1231	1.10	1260	1.17
1440	1179	1.01	1213	1.09	1245	1.17	1277	1.26	1307	1.34
1600	1223	1.15	1258	1.24	1291	1.33	1322	1.42	—	—
1760	1267	1.33	1301	1.42	—	—	—	—	—	—
1920	—	—	—	—	—	—	—	—	—	—
<b>1-HP Standard Motor &amp; Field Supplied High Static Drive(2)</b>										

**1-HP Standard Motor & Field Supplied High Static Drive (2)**

For Standard Evaporator Fan Speed (RPM), reference Table PD-56. Table includes Dehumidification (Hot Gas Reheat Option).

**\*Unit applications below 1280CFM**

- Electric heaters restricted on applications below 1280 CFM.
- Dehumidification (Hot Gas Reheat) or TXV with Frost and Crankcase Heaters are required on applications below 1280 CFM.

**Notes:**

Data includes pressure drop due to standard filters and wet coils.

Data does not include pressure drop due to reheat coil.

No accessories or options are included in pressure drop data.

Refer to Table PD-61 to determine additional static pressure drop due to other options/accessories

1 HP Fan Motor Heat (MBH) = 2.829 x Fan BHP + .4024.

1. BAYLSDR007A Required.

2. Field Supplied Fan Sheave AK41 required. Field Supplied Belt may be necessary.

Factory supplied motors, in commercial equipment, are definite purpose motors, specifically designed and tested to operate reliably and continuously at all cataloged conditions. Using the full horsepower range of our fan motors as shown in our tabular data will not result in nuisance tripping or premature motor failure. Our product's warranty will not be affected.





# Performance Data

# (5 Ton) High Efficiency

**Table PD-46— Belt Drive Evaporator Fan Performance — 5 Ton — THC060A3,A4,AW — Downflow Airflow**

CFM	External Static Pressure (Inches of Water)																			
	.10		.20		.30		.40		.50		.60		.70		.80		.90		1.00	
	RPM	BHP	RPM	BHP	RPM	BHP	RPM	BHP	RPM	BHP	RPM	BHP	RPM	BHP	RPM	BHP	RPM	BHP	RPM	BHP
	<b>1-HP Standard Motor &amp; Low Static Drive Accessory Kit (1)</b>						<b>1-HP Standard Motor &amp; Low Static Drive Accessory Kit (1)</b>						<b>1-HP Standard Motor &amp; Drive</b>							
1000*	—	—	537	0.13	608	0.17	667	0.21	721	0.25	770	0.30	817	0.35	861	0.39	905	0.45	944	0.50
1200*	517	0.15	588	0.19	652	0.23	712	0.28	764	0.33	811	0.38	856	0.43	898	0.48	939	0.54	978	0.59
1400*	576	0.21	645	0.26	702	0.31	756	0.36	808	0.41	856	0.48	900	0.54	941	0.59	979	0.65	1017	0.71
1600	640	0.31	703	0.36	757	0.41	806	0.47	854	0.52	899	0.58	944	0.65	985	0.73	1023	0.79	1060	0.86
1800	706	0.42	760	0.47	815	0.54	861	0.60	904	0.66	947	0.72	988	0.78	1028	0.86	1067	0.94	1104	1.02
2000	773	0.57	821	0.62	873	0.69	918	0.76	958	0.83	998	0.90	1036	0.96	1073	1.02	1111	1.10	1147	1.19
2200	840	0.75	885	0.80	930	0.87	977	0.95	1016	1.03	1053	1.10	1089	1.17	1124	1.24	1158	1.31	1191	1.39
2400	909	0.96	950	1.02	990	1.08	1034	1.16	1074	1.25	1110	1.00	1143	1.42	1177	1.50	—	—	—	—

**Table PD-46 — Continued**

CFM	External Static Pressure (Inches of Water)									
	1.10		1.20		1.30		1.40		1.50	
	RPM	BHP	RPM	BHP	RPM	BHP	RPM	BHP	RPM	BHP
	<b>1-HP Standard Motor &amp; Drive</b>									
1000*	985	0.56	1021	0.62	1058	0.68	1093	0.74	1126	0.80
1200*	1015	0.65	1051	0.71	1086	0.77	1120	0.84	1154	0.91
1400*	1052	0.77	1088	0.84	1121	0.90	1153	0.97	1185	1.04
1600	1093	0.92	1126	0.99	1160	1.06	1190	1.13	1222	1.20
1800	1138	1.10	1171	1.17	1203	1.25	1232	1.32	1262	1.39
2000	1182	1.28	1215	1.37	1246	1.46	—	—	—	—
2200	1226	1.48	—	—	—	—	—	—	—	—
2400	—	—	—	—	—	—	—	—	—	—

For Standard Evaporator Fan Speed (RPM), reference Table PD-56.

Table includes Dehumidification (Hot Gas Reheat Option).

**\*Unit applications below 1600 CFM**

• **Electric heaters restricted on applications below 1600 CFM.**

• **Dehumidification (Hot Gas Reheat) or TXV with Frost and Crankcase Heaters are required on applications below 1600 CFM.**

Notes:

Data includes pressure drop due to standard filters and wet coils.

Data does not include pressure drop due to reheat coil.

No accessories or options are included in pressure drop data.

Refer to Table PD-61 to determine additional static pressure drop due to other options/accessories

1 HP Fan Motor Heat (MBH) = 2.829 x Fan BHP + .4024.

1. BAYLSDR008A Required.

2. Field Supplied Fan Sheave AK56 required. Field Supplied Belt may be necessary.

Factory supplied motors, in commercial equipment, are definite purpose motors, specifically designed and tested to operate reliably and continuously at all cataloged conditions. Using the full horsepower range of our fan motors as shown in our tabular data will not result in nuisance tripping or premature motor failure. Our product's warranty will not be affected.

**Table PD-47 — Belt Drive Evaporator Fan Performance — 5 Ton — THC060A3,A4,AW — Horizontal Airflow**

CFM	External Static Pressure (Inches of Water)																			
	.10		.20		.30		.40		.50		.60		.70		.80		.90		1.00	
	RPM	BHP	RPM	BHP	RPM	BHP	RPM	BHP	RPM	BHP	RPM	BHP	RPM	BHP	RPM	BHP	RPM	BHP	RPM	BHP
	<b>1-HP Standard Motor &amp; Low Static Drive Accessory Kit (1)</b>									<b>1-HP Standard Motor &amp; Drive</b>										
1000*	507	0.11	599	0.16	671	0.21	735	0.26	792	0.31	843	0.37	889	0.42	931	0.48	971	0.54	1007	0.59
1200*	570	0.17	654	0.23	727	0.28	787	0.34	843	0.40	895	0.46	942	0.52	986	0.59	1026	0.66	1064	0.73
1400*	638	0.25	711	0.31	782	0.38	844	0.44	896	0.51	946	0.58	993	0.65	1037	0.72	1078	0.79	1117	0.86
1600	707	0.35	774	0.42	837	0.50	898	0.57	953	0.65	1001	0.72	1045	0.80	1087	0.87	1129	0.95	1168	1.03
1800	778	0.48	840	0.56	897	0.64	953	0.72	1008	0.81	1058	0.89	1102	0.98	1143	1.06	1181	1.15	1219	1.23
2000	850	0.65	908	0.73	961	0.81	1012	0.90	1062	1.00	1111	1.09	1157	1.19	1198	1.28	1237	1.37	1274	1.47
2200	923	0.84	978	0.93	1028	1.02	1075	1.12	1120	1.22	1166	1.32	1211	1.43	—	—	—	—	—	—
2400	997	1.07	1049	1.17	1096	1.27	1140	1.37	1183	1.48	—	—	—	—	—	—	—	—	—	—

**Table PD-47 — Continued**

CFM	External Static Pressure (Inches of Water)									
	1.10		1.20		1.30		1.40		1.50	
	RPM	BHP	RPM	BHP	RPM	BHP	RPM	BHP	RPM	BHP
	<b>1-HP Standard Motor &amp; Drive</b>									
1000*	1042	0.65	1078	0.70	1110	0.76	1142	0.82	1175	0.89
1200*	1099	0.80	1133	0.86	1166	0.93	1197	0.99	1227	1.06
1400*	1153	0.94	1188	1.02	1221	1.10	1253	1.18	1284	1.27
1600	1206	1.12	1241	1.20	1275	1.28	1306	1.37	1338	1.46
1800	1256	1.32	1291	1.41	1326	1.50	—	—	—	—
2000	—	—	—	—	—	—	—	—	—	—
2200	—	—	—	—	—	—	—	—	—	—
2400	—	—	—	—	—	—	—	—	—	—

For Standard Evaporator Fan Speed (RPM), reference Table PD-56.

Table includes Dehumidification (Hot Gas Reheat Option).

**\*Unit applications below 1600CFM**

• **Electric heaters restricted on applications below 1600 CFM.**

• **Dehumidification (Hot Gas Reheat) or TXV with Frost and Crankcase Heaters are required on applications below 1600 CFM.**

Notes:

Data includes pressure drop due to standard filters and wet coils.

Data does not include pressure drop due to reheat coil.

No accessories or options are included in pressure drop data.

Refer to Table PD-61 to determine additional static pressure drop due to other options/accessories

1 HP Fan Motor Heat (MBH) = 2.829 x Fan BHP + .4024.

1. BAYLSDR008A Required.

2. Field Supplied Fan Sheave AK56 required. Field Supplied Belt may be necessary.

Factory supplied motors, in commercial equipment, are definite purpose motors, specifically designed and tested to operate reliably and continuously at all cataloged conditions. Using the full horsepower range of our fan motors as shown in our tabular data will not result in nuisance tripping or premature motor failure. Our product's warranty will not be affected.



# Performance Data

# (6 Ton) High Efficiency

**Table PD-48 – Belt Drive Evaporator Fan Performance – 6 Ton – THC072A3,A4,AW\* – Downflow Airflow– Standard Refrigeration System**

CFM	External Static Pressure (Inches of Water)																				
	.10		.20		.30		.40		.50		.60		.70		.80		.90		1.00		
RPM	BHP	RPM	BHP	RPM	BHP	RPM	BHP	RPM	BHP	RPM	BHP	RPM	BHP	RPM	BHP	RPM	BHP	RPM	BHP	RPM	BHP
<b>1-HP Standard Motor &amp; Field Supplied Low Static Drive (1)</b>										<b>1-HP Standard Motor &amp; Drive</b>											
1920	—	—	—	—	588	0.35	643	0.43	693	0.50	738	0.57	782	0.65	823	0.73	862	0.81	900	0.89	
2160	—	—	564	0.37	618	0.44	672	0.52	721	0.60	765	0.68	806	0.76	847	0.85	885	0.93	922	1.02	
2400	—	—	602	0.47	652	0.54	701	0.63	750	0.72	794	0.81	834	0.90	873	0.98	909	1.08	945	1.17	
2640	589	0.50	642	0.59	690	0.67	734	0.76	779	0.85	822	0.95	864	1.05	901	1.15	936	1.24	971	1.34	
2880	634	0.63	682	0.74	728	0.82	770	0.91	810	1.01	851	1.11	892	1.22	930	1.33	965	1.44	999	1.54	

**Table PD-48 – Continued**

CFM	External Static Pressure (Inches of Water)																				
	1.10		1.20		1.30		1.40		1.50		1.60		1.70		1.80		1.90		2.00		
RPM	BHP	RPM	BHP	RPM	BHP	RPM	BHP	RPM	BHP	RPM	BHP	RPM	BHP	RPM	BHP	RPM	BHP	RPM	BHP	RPM	BHP
<b>1-HP Standard Motor &amp; Drive</b>				<b>1-HP Standard Motor &amp; High Static Drive Kit (or 2 HP Oversized Motor &amp; Drive)</b>																	
1920	937	0.98	971	1.06	1004	1.14	1037	1.22	1068	1.30	1097	1.38	1127	1.47	1154	1.55	1182	1.64	1210	1.74	
2160	957	1.12	991	1.21	1024	1.30	1057	1.40	1087	1.49	1117	1.58	1146	1.67	1174	1.76	1201	1.85	1227	1.95	
2400	980	1.27	1013	1.37	1046	1.47	1076	1.57	1106	1.68	1137	1.78	1166	1.89	1194	1.99	1220	2.08	1248	2.19	
2640	1004	1.44	1036	1.55	1067	1.65	1098	1.77	1129	1.88	1158	1.99	1185	2.10	1214	2.22	—	—	—	—	
2880	1030	1.64	1061	1.75	1092	1.86	1123	1.98	1151	2.09	1181	2.22	—	—	—	—	—	—	—	—	
<b>2-HP Oversized Motor &amp; Drive</b>																					

For Standard Evaporator Fan Speed (RPM), reference Table PD-56.

Notes:

Data includes pressure drop due to standard filters and wet coils.

No accessories or options are included in pressure drop data.

Refer to Table PD-61 to determine additional static pressure drop due to other options/accessories

1-HP Fan Motor Heat (MBH) = 2.829 x Fan BHP+.4024. 2-HP Fan Motor Heat (MBH) = 3.000 x Fan BHP+.5000

1. Field Supplied Fan Sheave AK84 and Belt AX34 required.

Factory supplied motors, in commercial equipment, are definite purpose motors, specifically designed and tested to operate reliably and continuously at all cataloged conditions. Using the full horsepower range of our fan motors as shown in our tabular data will not result in nuisance tripping or premature motor failure. Our product's warranty will not be affected.

**Table PD-49 – Belt Drive Evaporator Fan Performance – 6 Ton – THC072A3,A4,AW – Horizontal Airflow– Standard Refrigeration System**

CFM	External Static Pressure (Inches of Water)																				
	.10		.20		.30		.40		.50		.60		.70		.80		.90		1.00		
RPM	BHP	RPM	BHP	RPM	BHP	RPM	BHP	RPM	BHP	RPM	BHP	RPM	BHP	RPM	BHP	RPM	BHP	RPM	BHP	RPM	BHP
<b>1-HP Standard Motor &amp; Field Supplied Low Static Drive (1)</b>										<b>1-HP Standard Motor &amp; Drive</b>											
1920	—	—	580	0.33	641	0.41	692	0.47	738	0.54	783	0.63	827	0.71	870	0.79	912	0.88	951	0.96	
2160	578	0.37	623	0.43	679	0.51	731	0.59	775	0.67	817	0.74	857	0.83	896	0.93	935	1.02	974	1.12	
2400	633	0.49	673	0.56	718	0.63	769	0.72	814	0.82	855	0.90	893	0.98	929	1.08	965	1.18	999	1.29	
2640	688	0.64	725	0.71	762	0.79	808	0.87	853	0.98	894	1.09	931	1.17	966	1.26	1000	1.36	1032	1.47	
2880	743	0.81	778	0.90	811	0.98	848	1.06	891	1.16	932	1.28	970	1.40	1004	1.49	1037	1.59	1068	1.69	
<b>2-HP Oversized Motor &amp; Drive</b>																		<b>1-HP Standard Motor &amp; High Static Drive Kit (or 2-HP Oversized Motor)</b>			

**Table PD-49 – Continued**

CFM	External Static Pressure (Inches of Water)																				
	1.10		1.20		1.30		1.40		1.50		1.60		1.70		1.80		1.90		2.00		
RPM	BHP	RPM	BHP	RPM	BHP	RPM	BHP	RPM	BHP	RPM	BHP	RPM	BHP	RPM	BHP	RPM	BHP	RPM	BHP	RPM	BHP
<b>1-HP Standard Motor &amp; Drive</b>				<b>1-HP Standard Motor &amp; High Static Drive Kit (or 2 HP Oversized Motor &amp; Drive)</b>																	
1920	990	1.05	1026	1.14	1062	1.24	1096	1.33	1130	1.43	1160	1.52	1190	1.61	1218	1.71	1247	1.80	1273	1.90	
2160	1010	1.21	1047	1.31	1082	1.40	1116	1.50	1150	1.61	1182	1.71	1211	1.81	1242	1.92	1271	2.03	1298	2.14	
2400	1035	1.39	1070	1.50	1104	1.60	1137	1.70	1168	1.81	1201	1.92	1232	2.03	1261	2.14	1291	2.26	—	—	
2640	1065	1.59	1097	1.71	1129	1.82	1161	1.93	1192	2.05	1223	2.16	1252	2.27	—	—	—	—	—	—	
2880	1099	1.80	1130	1.93	1159	2.05	1188	2.18	1217	2.30	—	—	—	—	—	—	—	—	—	—	
<b>2-HP Oversized Motor &amp; Drive</b>																		<b>2-HP Oversized Motor &amp; Field Supplied Drive (2)</b>			

For Standard Evaporator Fan Speed (RPM), reference Table PD-56.

Notes:

Data includes pressure drop due to standard filters and wet coils.

No accessories or options are included in pressure drop data.

Refer to Table PD-61 to determine additional static pressure drop due to other options/accessories.

1-HP Fan Motor Heat (MBH) = 2.829 x Fan BHP+.4024.

2-HP Fan Motor Heat (MBH) = 3.000 x Fan BHP+.5000

1. Field Supplied Fan Sheave AK84 and Belt AX34 required.

2. Field Supplied Fan Sheave AK54 and Belt AX30.

Factory supplied motors, in commercial equipment, are definite purpose motors, specifically designed and tested to operate reliably and continuously at all cataloged conditions. Using the full horsepower range of our fan motors as shown in our tabular data will not result in nuisance tripping or premature motor failure. Our product's warranty will not be affected.



# Performance Data

(7½ Ton)  
High Efficiency

**Table PD-50 – Belt Drive Evaporator Fan Performance – 7½ Ton – THC092A3,A4,AW – Downflow Airflow**

CFM	External Static Pressure (Inches of Water)																			
	.10		.20		.30		.40		.50		.60		.70		.80		.90		1.00	
	RPM	BHP	RPM	BHP	RPM	BHP	RPM	BHP	RPM	BHP	RPM	BHP	RPM	BHP	RPM	BHP	RPM	BHP	RPM	BHP
<b>2-HP Standard Motor &amp; Low Static Drive Accessory Kit (1)</b>																				
1500*	—	—	—	—	—	—	510	0.30	557	0.39	602	0.48	643	0.57	682	0.66	718	0.76	753	0.87
1800*	—	—	—	—	481	0.27	534	0.36	579	0.45	621	0.55	661	0.65	699	0.75	735	0.86	770	0.97
2100*	—	—	—	—	506	0.33	557	0.42	604	0.52	645	0.62	683	0.73	719	0.85	754	0.97	787	1.08
2400	—	—	487	0.32	536	0.40	583	0.50	627	0.61	669	0.72	708	0.83	743	0.95	776	1.08	808	1.21
2700	—	—	522	0.41	569	0.50	611	0.60	653	0.71	693	0.83	731	0.95	768	1.07	801	1.20	832	1.33
3000	—	—	559	0.51	604	0.61	643	0.71	682	0.83	719	0.95	755	1.08	791	1.21	824	1.35	856	1.48
3300	—	—	599	0.63	639	0.74	678	0.86	713	0.97	748	1.09	783	1.23	815	1.37	848	1.52	880	1.66
3600	601	0.68	640	0.79	675	0.89	713	1.02	748	1.14	780	1.26	811	1.40	844	1.55	874	1.70	904	1.86
<b>2-HP Standard Motor &amp; Drive</b>																				

**Table PD-50— Continued**

CFM	External Static Pressure (Inches of Water)																			
	1.10		1.20		1.30		1.40		1.50		1.60		1.70		1.80		1.90		2.00	
	RPM	BHP	RPM	BHP	RPM	BHP	RPM	BHP	RPM	BHP	RPM	BHP	RPM	BHP	RPM	BHP	RPM	BHP	RPM	BHP
<b>2-HP Standard Motor &amp; Drive</b>																				
1500*	785	0.99	818	1.11	847	1.23	875	1.35	903	1.48	930	1.62	954	1.74	977	1.88	1001	2.01	1023	2.15
1800*	802	1.09	833	1.20	863	1.32	892	1.46	920	1.59	947	1.73	973	1.87	998	2.02	1023	2.17	1048	2.32
2100*	819	1.21	850	1.33	880	1.46	909	1.59	936	1.72	963	1.86	989	2.00	1014	2.15	1039	2.30	1064	2.46
2400	839	1.34	868	1.48	898	1.61	926	1.75	953	1.89	980	2.04	1006	2.18	1032	2.34	1056	2.49	1080	2.64
2700	862	1.48	891	1.62	918	1.77	946	1.92	971	2.07	998	2.23	1023	2.38	1049	2.54	1074	2.70	1097	2.86
3000	886	1.63	915	1.78	942	1.93	968	2.09	994	2.25	1019	2.42	1044	2.59	1067	2.75	1092	2.93	1115	3.09
3300	910	1.81	939	1.96	967	2.12	993	2.28	1019	2.45	1043	2.62	1066	2.79	1091	2.98	1113	3.15	1136	3.34
3600	933	2.01	962	2.17	990	2.33	1016	2.49	1042	2.66	1067	2.84	1091	3.02	1114	3.21	1137	3.39	1158	3.58
<b>3-HP Oversized Motor &amp; Drive</b>																				

**2-HP Standard Motor & Low Static Drive Accessory Kit (1)**

For Standard Evaporator Fan Speed (RPM), reference Table PD-56.  
Table includes Dehumidification (Hot Gas Reheat Option).

**\*Unit applications below 2400 CFM**

- Electric heaters restricted on applications below 2400 CFM.
- Dehumidification (Hot Gas Reheat) or TXV with Froststat and Crankcase Heaters are required on applications below 2400 CFM.

Notes:

- Data includes pressure drop due to standard filters and wet coils.
- Data does not include pressure drop due to reheat coil.
- No accessories or options are included in pressure drop data.
- Refer to Table PD-61 to determine additional static pressure drop due to other options/accessories
- 2-HP Fan Motor Heat (MBH) = 2.000 x Fan BHP + 5000.
- 3-HP Fan Motor Heat (MBH) = 2.900 x Fan BHP + 4750
- 1. BAYLSDR009A Required.

Factory supplied motors, in commercial equipment, are definite purpose motors, specifically designed and tested to operate reliably and continuously at all cataloged conditions. Using the full horsepower range of our fan motors as shown in our tabular data will not result in nuisance tripping or premature motor failure. Our product's warranty will not be affected.



# Performance Data

# (7½ Ton) High Efficiency

**Table PD-51 – Belt Drive Evaporator Fan Performance – 7½ Ton – THC092A3,A4,AW–Horizontal Airflow**

CFM	External Static Pressure (Inches of Water)																			
	.10		.20		.30		.40		.50		.60		.70		.80		.90		1.00	
	RPM	BHP	RPM	BHP	RPM	BHP	RPM	BHP	RPM	BHP	RPM	BHP	RPM	BHP	RPM	BHP	RPM	BHP	RPM	BHP
<b>2-HP Standard Motor &amp; Low Static Drive Accessory Kit (1)</b>																				
1500*	—	—	—	—	509	0.26	558	0.32	601	0.39	640	0.45	678	0.52	715	0.59	750	0.67	783	0.75
1800*	—	—	472	0.24	542	0.34	597	0.42	640	0.50	678	0.58	714	0.65	748	0.73	780	0.81	811	0.89
2100*	—	—	511	0.33	568	0.42	628	0.52	678	0.63	718	0.72	754	0.81	787	0.90	817	0.99	846	1.08
2400	502	0.36	552	0.43	603	0.52	653	0.63	707	0.75	754	0.88	792	0.99	825	1.09	857	1.19	886	1.30
2700	554	0.49	595	0.56	644	0.66	686	0.77	732	0.89	780	1.03	824	1.17	863	1.30	895	1.42	925	1.54
3000	605	0.65	644	0.73	684	0.82	726	0.94	765	1.06	806	1.20	849	1.35	891	1.51	929	1.66	962	1.80
3300	658	0.84	694	0.93	728	1.02	767	1.15	805	1.28	840	1.40	876	1.55	916	1.71	955	1.89	991	2.06
3600	711	1.07	746	1.18	776	1.27	809	1.38	846	1.52	880	1.66	912	1.80	943	1.95	980	2.13	1016	2.30
<b>2-HP Standard Motor &amp; Drive</b>																				

**Table PD-51 – Continued**

CFM	External Static Pressure (Inches of Water)																			
	1.10		1.20		1.30		1.40		1.50		1.60		1.70		1.80		1.90		2.00	
	RPM	BHP	RPM	BHP	RPM	BHP	RPM	BHP	RPM	BHP	RPM	BHP	RPM	BHP	RPM	BHP	RPM	BHP	RPM	BHP
<b>2-HP Standard Motor &amp; Drive</b>																				
1500*	815	0.83	847	0.91	876	0.99	904	1.07	932	1.16	958	1.25	985	1.34	1009	1.43	1033	1.51	1057	1.61
1800*	842	0.98	872	1.07	901	1.16	929	1.25	957	1.35	983	1.44	1008	1.54	1034	1.64	1058	1.74	1081	1.84
2100*	876	1.18	904	1.27	931	1.36	956	1.46	982	1.55	1008	1.66	1034	1.77	1059	1.87	1083	1.99	1107	2.10
2400	913	1.40	941	1.51	966	1.61	991	1.71	1017	1.82	1040	1.92	1064	2.04	1087	2.14	1110	2.26	1132	2.37
2700	954	1.66	981	1.77	1006	1.89	1030	2.00	1054	2.12	1077	2.24	1100	2.36	1121	2.47	1144	2.60	1164	2.71
3000	992	1.94	1019	2.07	1045	2.20	1069	2.32	1094	2.46	1116	2.58	1138	2.71	1160	2.84	1181	2.97	1202	3.10
3300	1025	2.22	1055	2.38	1082	2.53	1108	2.67	1132	2.82	1156	2.96	1178	3.11	1200	3.25	1221	3.39	—	—
3600	1052	2.50	1085	2.69	1117	2.88	1144	3.05	1170	3.21	1193	3.37	—	—	—	—	—	—	—	—
<b>3-HP Oversized Motor &amp; Drive</b>																				

For Standard Evaporator Fan Speed (RPM), reference Table PD-56.

Table includes Dehumidification (Hot Gas Reheat Option).

**\*Unit applications below 2400 CFM**

- Electric heaters restricted on applications below 2400 CFM.
- Dehumidification (Hot Gas Reheat) or TXV with Froststat and Crankcase Heaters are required on applications below 2400 CFM.

Notes:

Data includes pressure drop due to standard filters and wet coils.

Data does not include pressure drop due to reheat coil.

No accessories or options are included in pressure drop data.

Refer to Table PD-61 to determine additional static pressure drop due to other options/accessories

1 HP Fan Motor Heat (MBH) = 2.829 x Fan BHP+.4024.

2-HP Fan Motor Heat (MBH) = 2.000 x Fan BHP+.5000.

3-HP Fan Motor Heat (MBH) = 2.900 x Fan BHP+.4750

1. BAYLSDR009A Required.

2. Field Supplied Fan Sheave AK79 and Belt AX38 required.

Factory supplied motors, in commercial equipment, are definite purpose motors, specifically designed and tested to operate reliably and continuously at all cataloged conditions. Using the full horsepower range of our fan motors as shown in our tabular data will not result in nuisance tripping or premature motor failure. Our product's warranty will not be affected.



# Performance Data

## (8½ Ton) High Efficiency

**Table PD-52— Belt Drive Evaporator Fan Performance — 8½ Ton — THC102A3,A4,AW — Downflow Airflow**

CFM	External Static Pressure (Inches of Water)																			
	.10		.20		.30		.40		.50		.60		.70		.80		.90		1.00	
	RPM	BHP	RPM	BHP	RPM	BHP	RPM	BHP	RPM	BHP	RPM	BHP	RPM	BHP	RPM	BHP	RPM	BHP	RPM	BHP
<b>2-HP Standard Motor &amp; Low Static Drive Accessory Kit (1)</b>																				
1700*	—	—	—	—	481	0.26	533	0.35	578	0.44	621	0.54	661	0.64	700	0.74	736	0.85	770	0.96
2040*	—	—	—	—	511	0.34	562	0.43	608	0.52	649	0.63	686	0.74	722	0.85	757	0.97	791	1.09
2380*	—	—	496	0.33	545	0.42	592	0.52	637	0.63	678	0.74	716	0.86	751	0.98	784	1.11	815	1.24
2720	—	—	539	0.44	584	0.53	626	0.64	668	0.76	708	0.88	746	1.00	781	1.12	814	1.26	845	1.40
3060	—	—	583	0.58	626	0.68	665	0.78	703	0.90	740	1.04	775	1.17	810	1.30	843	1.44	875	1.58
3400	—	—	628	0.72	669	0.84	706	0.96	741	1.08	775	1.21	809	1.36	841	1.51	873	1.65	904	1.81
3400	641	0.81	677	0.92	713	1.04	749	1.17	781	1.30	813	1.43	845	1.58	875	1.73	905	1.89	935	2.06
4080	693	1.03	726	1.15	758	1.27	792	1.41	824	1.56	854	1.69	883	1.83	912	1.99	940	2.16	968	2.33
<b>2-HP Standard Motor &amp; Drive</b>																				

**Table PD-52 — Continued**

CFM	External Static Pressure (Inches of Water)																			
	1.10		1.20		1.30		1.40		1.50		1.60		1.70		1.80		1.90		2.00	
	RPM	BHP	RPM	BHP	RPM	BHP	RPM	BHP	RPM	BHP	RPM	BHP	RPM	BHP	RPM	BHP	RPM	BHP	RPM	BHP
<b>2-HP Standard Motor &amp; Drive</b>																				
1700*	802	1.07	833	1.19	864	1.32	893	1.45	921	1.59	948	1.72	972	1.86	998	2.01	1022	2.15	1045	2.30
2040*	823	1.21	854	1.34	884	1.47	913	1.60	940	1.73	967	1.87	993	2.01	1018	2.16	1043	2.32	1068	2.48
2380*	846	1.37	876	1.51	906	1.65	934	1.79	962	1.93	988	2.08	1014	2.22	1038	2.37	1064	2.53	1087	2.69
2720	874	1.54	904	1.69	930	1.84	958	2.00	983	2.14	1010	2.30	1035	2.46	1060	2.62	1084	2.78	1109	2.95
3060	905	1.73	933	1.89	960	2.05	986	2.20	1010	2.37	1035	2.54	1059	2.71	1083	2.89	1107	3.06	1131	3.24
3400	933	1.96	962	2.11	990	2.27	1016	2.44	1041	2.62	1065	2.79	1089	2.97	1112	3.15	1134	3.34	—	—
3400	964	2.22	992	2.39	1018	2.55	1045	2.72	1071	2.90	1095	3.08	1118	3.26	1141	3.45	—	—	—	—
4080	995	2.51	1023	2.69	1048	2.86	1075	3.05	1100	3.23	1124	3.41	—	—	—	—	—	—	—	—
<b>3-HP Oversized Motor &amp; Drive</b>																				

For Standard Evaporator Fan Speed (RPM), reference Table PD-56.  
Table includes Dehumidification (Hot Gas Reheat Option).

**\*Unit applications below 2720 CFM**

- Electric heaters restricted on applications below 2720 CFM.
- Dehumidification (Hot Gas Reheat) or TXV with Froststat and Crankcase Heaters are required on applications below 2720 CFM.

**Notes:**

- Data includes pressure drop due to standard filters and wet coils.
- Data does not include pressure drop due to reheat coil.
- No accessories or options are included in pressure drop data.
- Refer to Table PD-61 to determine additional static pressure drop due to other options/accessories.
- 1 HP Fan Motor Heat (MBH) = 2.829 x Fan BHP + 4024.
- 2-HP Fan Motor Heat (MBH) = 2.000 x Fan BHP + 5000.
- 3-HP Fan Motor Heat (MBH) = 2.900 x Fan BHP + 4750.
- 1. BAYLSDR009A Required.

Factory supplied motors, in commercial equipment, are definite purpose motors, specifically designed and tested to operate reliably and continuously at all cataloged conditions. Using the full horsepower range of our fan motors as shown in our tabular data will not result in nuisance tripping or premature motor failure. Our product's warranty will not be affected.



# Performance Data

# (8½ Ton) High Efficiency

**Table PD-53 — Belt Drive Evaporator Fan Performance — 8½ Ton — THC102A3,A4,AW — Horizontal Airflow**

CFM	External Static Pressure (Inches of Water)																			
	.10		.20		.30		.40		.50		.60		.70		.80		.90		1.00	
	RPM	BHP	RPM	BHP	RPM	BHP	RPM	BHP	RPM	BHP	RPM	BHP	RPM	BHP	RPM	BHP	RPM	BHP	RPM	BHP
<b>2-HP Standard Motor &amp; Low Static Drive Accessory Kit (1)</b>																				
1700*	—	—	473	0.24	542	0.32	591	0.40	633	0.47	672	0.55	707	0.62	742	0.70	774	0.77	807	0.86
2040*	—	—	513	0.32	575	0.42	634	0.53	679	0.62	719	0.71	754	0.80	787	0.89	817	0.97	846	1.06
2380*	509	0.36	562	0.45	612	0.54	666	0.66	719	0.78	763	0.90	800	1.01	832	1.11	863	1.21	893	1.32
2720	570	0.52	612	0.60	660	0.71	703	0.81	751	0.95	798	1.09	841	1.23	877	1.36	909	1.48	939	1.60
3060	631	0.72	667	0.80	709	0.91	750	1.03	788	1.15	830	1.29	873	1.45	914	1.62	951	1.77	983	1.92
3400	692	0.96	726	1.05	760	1.15	800	1.29	836	1.42	870	1.56	907	1.71	945	1.88	984	2.06	1020	2.24
3740	754	1.26	786	1.36	815	1.46	850	1.59	886	1.74	918	1.88	949	2.03	980	2.19	1015	2.37	1052	2.57
4080	817	1.61	848	1.72	874	1.83	903	1.95	935	2.10	968	2.26	998	2.42	1026	2.58	1054	2.75	1085	2.94
<b>2-HP Standard Motor &amp; Drive</b>											<b>3-HP Oversized Motor &amp; Drive</b>									

**Table PD-53 — Continued**

CFM	External Static Pressure (Inches of Water)																			
	1.10		1.20		1.30		1.40		1.50		1.60		1.70		1.80		1.90		2.00	
	RPM	BHP	RPM	BHP	RPM	BHP	RPM	BHP	RPM	BHP	RPM	BHP	RPM	BHP	RPM	BHP	RPM	BHP	RPM	BHP
<b>2-HP Standard Motor &amp; Drive</b>																				
1700*	839	0.94	869	1.03	898	1.12	926	1.21	953	1.30	980	1.40	1005	1.49	1031	1.59	1054	1.68	1078	1.78
2040*	876	1.16	903	1.25	930	1.34	957	1.44	984	1.54	1010	1.64	1036	1.75	1061	1.86	1084	1.96	1108	2.07
2380*	920	1.42	946	1.52	973	1.63	998	1.73	1021	1.83	1047	1.95	1069	2.05	1093	2.16	1115	2.27	1138	2.39
2720	967	1.72	994	1.84	1018	1.96	1042	2.07	1066	2.19	1089	2.31	1112	2.43	1134	2.55	1155	2.67	1176	2.79
3080	1012	2.06	1039	2.19	1065	2.32	1090	2.46	1113	2.59	1136	2.73	1158	2.86	1179	2.99	1199	3.12	1220	3.26
3400	1052	2.41	1083	2.58	1109	2.73	1135	2.88	1159	3.04	1183	3.19	1204	3.33	—	—	—	—	—	—
3740	1086	2.77	1119	2.96	1149	3.15	1178	3.34	—	—	—	—	—	—	—	—	—	—	—	—
4080	1117	3.14	1151	3.36	—	—	—	—	—	—	—	—	—	—	—	—	—	—	—	—
<b>3-HP Oversized Motor &amp; Drive</b>																				

For Standard Evaporator Fan Speed (RPM), reference Table PD-56.  
Table includes Dehumidification (Hot Gas Reheat Option).

**\*Unit applications below 2720 CFM**

- Electric heaters restricted on applications below 2720 CFM.
- Dehumidification (Hot Gas Reheat) or TXV with Frost and Crankcase Heaters are required on applications below 2720 CFM.

**Notes:**

Data includes pressure drop due to standard filters and wet coils.  
Data does not include pressure drop due to reheat coil.

No accessories or options are included in pressure drop data.

Refer to Table PD-61 to determine additional static pressure drop due to other options/accessories

1-HP Fan Motor Heat (MBH) = 2.829 x Fan BHP+.4024.

2-HP Fan Motor Heat (MBH) = 2.000 x Fan BHP+.5000.

3-HP Fan Motor Heat (MBH) = 2.900 x Fan BHP+.4750

1. BAYLSDR009A Required.

Factory supplied motors, in commercial equipment, are definite purpose motors, specifically designed and tested to operate reliably and continuously at all cataloged conditions. Using the full horsepower range of our fan motors as shown in our tabular data will not result in nuisance tripping or premature motor failure. Our product's warranty will not be affected.



# Performance Data

# (10 Ton) High Efficiency

**Table PD-54— Belt Drive Evaporator Fan Performance — 10 Ton — THC120A3,A4,AW — Downflow Airflow**

CFM	External Static Pressure (Inches of Water)																			
	.10		.20		.30		.40		.50		.60		.70		.80		.90		1.00	
	RPM	BHP	RPM	BHP	RPM	BHP	RPM	BHP	RPM	BHP	RPM	BHP	RPM	BHP	RPM	BHP	RPM	BHP	RPM	BHP
<b>3-HP Standard Motor &amp; Low Static Drive Accessory Kit(1)</b>																				
2000*	—	—	—	—	—	—	568	0.43	613	0.53	653	0.64	691	0.75	727	0.86	763	0.98	797	1.10
2400*	—	—	—	—	—	—	606	0.56	650	0.67	691	0.78	728	0.90	763	1.02	796	1.16	826	1.29
2800*	—	—	564	0.50	607	0.60	649	0.71	689	0.83	728	0.95	766	1.08	801	1.21	833	1.35	864	1.50
3200	576	0.57	618	0.67	659	0.79	697	0.90	734	1.03	770	1.17	804	1.31	839	1.45	871	1.60	901	1.74
3600	638	0.78	675	0.89	714	1.02	749	1.14	782	1.27	815	1.41	847	1.57	879	1.73	909	1.89	939	2.04
4000	701	1.04	734	1.16	768	1.30	803	1.44	834	1.58	863	1.72	894	1.87	923	2.04	952	2.21	979	2.39
4400	764	1.36	795	1.49	825	1.63	857	1.79	888	1.95	916	2.10	943	2.25	970	2.41	997	2.59	1024	2.78
4800	828	1.74	857	1.88	884	2.02	913	2.18	942	2.36	970	2.53	996	2.70	1021	2.86	1045	3.03	1070	3.22
<b>3-HP Standard Motor &amp; Drive</b>																				

**Table PD-54 — Continued**

CFM	External Static Pressure (Inches of Water)																			
	1.10		1.20		1.30		1.40		1.50		1.60		1.70		1.80		1.90		2.00	
	RPM	BHP	RPM	BHP	RPM	BHP	RPM	BHP	RPM	BHP	RPM	BHP	RPM	BHP	RPM	BHP	RPM	BHP	RPM	BHP
<b>3-HP Oversized Motor &amp; Drive</b>																				
2000*	828	1.22	859	1.35	888	1.48	917	1.61	945	1.75	971	1.88	998	2.03	1023	2.19	1048	2.35	1072	2.50
2400*	858	1.43	888	1.56	916	1.70	945	1.85	972	1.99	998	2.14	1023	2.29	1050	2.45	1073	2.60	1097	2.76
2800*	894	1.65	921	1.79	949	1.95	975	2.11	1001	2.27	1027	2.43	1051	2.59	1076	2.75	1100	2.92	1123	3.09
3200	931	1.89	959	2.06	986	2.22	1012	2.39	1037	2.56	1061	2.74	1084	2.91	1108	3.09	1131	3.28	1153	3.46
3600	969	2.21	997	2.37	1024	2.54	1050	2.72	1074	2.89	1098	3.08	1122	3.27	1145	3.46	1166	3.65	1188	3.85
4000	1007	2.57	1034	2.74	1062	2.93	1087	3.11	1112	3.29	1136	3.47	1159	3.66	1182	3.86	1204	4.07	1226	4.28
4400	1050	2.97	1075	3.17	1101	3.36	1126	3.55	1150	3.75	1173	3.94	1198	4.15	1219	4.34	1241	4.54	1264	4.77
4800	1095	3.42	1119	3.62	1143	3.83	1166	4.05	1189	4.26	1212	4.47	1235	4.68	1258	4.90	1280	5.12	1300	5.32
<b>5-HP Oversized Motor &amp; Drive</b>																				

For Standard Evaporator Fan Speed (RPM), reference Table PD-56.  
Table includes Dehumidification (Hot Gas Reheat Option).

**\*Unit applications below 3200 CFM**

- Electric heaters restricted on applications below 3200 CFM.
- Dehumidification (Hot Gas Reheat) or TXV with Froststat and Crankcase Heaters are required on applications below 3200 CFM.

**Notes:**

Data includes pressure drop due to standard filters and wet coils.  
Data does not include pressure drop due to reheat coil.  
No accessories or options are included in pressure drop data.  
Refer to Table PD-61 to determine additional static pressure drop due to other options/accessories.  
3-HP Fan Motor Heat (MBH) = 2.900 x Fan BHP+.475.  
5-HP Fan Motor Heat (MBH) = 2.950 x Fan BHP+.470.  
1. BAYLSDR010A Required.

Factory supplied motors, in commercial equipment, are definite purpose motors, specifically designed and tested to operate reliably and continuously at all cataloged conditions. Using the full horsepower range of our fan motors as shown in our tabular data will not result in nuisance tripping or premature motor failure. Our product's warranty will not be affected.



# Performance Data

# (10 Ton) High Efficiency

**Table PD-55— Belt Drive Evaporator Fan Performance — 10 Ton — THC120A3,A4,AW —Horizontal Airflow**

CFM	External Static Pressure (Inches of Water)																			
	.10		.20		.30		.40		.50		.60		.70		.80		.90		1.00	
	RPM	BHP	RPM	BHP	RPM	BHP	RPM	BHP	RPM	BHP	RPM	BHP	RPM	BHP	RPM	BHP	RPM	BHP	RPM	BHP
<b>3-HP Standard Motor &amp; Low Static Drive Accessory Kit (1)</b>																				
2000*	—	—	—	—	584	0.43	639	0.53	682	0.62	721	0.71	755	0.79	787	0.88	818	0.97	849	1.06
2400*	—	—	578	0.48	627	0.57	683	0.70	734	0.83	776	0.94	812	1.05	845	1.15	876	1.26	904	1.36
2800*	596	0.58	640	0.67	686	0.79	728	0.90	776	1.04	822	1.19	865	1.34	900	1.47	932	1.60	962	1.73
3200	671	0.85	706	0.93	748	1.06	787	1.19	824	1.32	864	1.47	906	1.64	946	1.81	983	1.97	1015	2.13
3600	746	1.18	777	1.27	811	1.39	849	1.54	883	1.68	916	1.82	950	1.98	987	2.16	1024	2.35	1060	2.55
4000	822	1.59	850	1.70	879	1.81	912	1.95	946	2.12	977	2.28	1006	2.43	1035	2.60	1067	2.79	1101	2.99
4400	898	2.09	925	2.21	950	2.32	977	2.46	1008	2.63	1039	2.81	1067	2.98	1094	3.16	1121	3.33	1147	3.52
4800	974	2.69	1000	2.83	1023	2.95	1046	3.07	1072	3.23	1101	3.42	1130	3.62	1156	3.81	1181	4.00	1206	4.19
<b>5-HP Oversized Motor &amp; Drive</b>																				

**Table PD-55 — Continued**

CFM	External Static Pressure (Inches of Water)																			
	1.10		1.20		1.30		1.40		1.50		1.60		1.70		1.80		1.90		2.00	
	RPM	BHP	RPM	BHP	RPM	BHP	RPM	BHP	RPM	BHP	RPM	BHP	RPM	BHP	RPM	BHP	RPM	BHP	RPM	BHP
<b>3-HP Standard Motor &amp; Drive</b>																				
2000*	877	1.15	906	1.24	933	1.33	961	1.43	988	1.54	1014	1.64	1038	1.74	1063	1.85	1087	1.96	1111	2.07
2400*	931	1.47	958	1.58	983	1.68	1008	1.78	1032	1.89	1056	2.00	1080	2.11	1103	2.22	1126	2.34	1149	2.46
2800*	989	1.84	1015	1.97	1040	2.09	1064	2.21	1087	2.34	1110	2.46	1132	2.58	1154	2.71	1176	2.83	1196	2.95
3200	1044	2.28	1072	2.42	1097	2.57	1122	2.71	1145	2.84	1168	2.99	1189	3.12	1210	3.27	1231	3.41	1250	3.54
3600	1093	2.74	1124	2.92	1151	3.09	1176	3.25	1201	3.42	1224	3.58	1246	3.74	1268	3.90	1289	4.06	1308	4.20
4000	1135	3.21	1167	3.42	1198	3.63	1227	3.84	1254	4.05	1278	4.23	1301	4.41	1323	4.60	1344	4.77	1365	4.95
4400	1177	3.73	1207	3.96	1239	4.19	1268	4.42	1297	4.67	1324	4.90	1351	5.12	1376	5.35	1398	5.56	1420	5.75
4800	1229	4.39	1254	4.59	1282	4.83	1310	5.07	1338	5.32	1365	5.58	—	—	—	—	—	—	—	—
<b>5-HP Oversized Motor &amp; Drive</b>																				

**3-HP Standard Motor & Low Static Drive Accessory Kit (1)**

For Standard Evaporator Fan Speed (RPM), reference Table PD-56.  
Table includes Dehumidification (Hot Gas Reheat Option).

**\*Unit applications below 3200 CFM**

- Electric heaters restricted on applications below 3200 CFM.
- Dehumidification (Hot Gas Reheat) or TXV with Frost and Crankcase Heaters are required on applications below 3200 CFM.

**Notes:**

Data includes pressure drop due to standard filters and wet coils.  
Data does not include pressure drop due to reheat coil.

No accessories or options are included in pressure drop data.

Refer to Table PD-61 to determine additional static pressure drop due to other options/accessories

3-HP Fan Motor Heat (MBH) = 2.900 x Fan BHP+.475.

5-HP Fan Motor Heat (MBH) = 2.950 x Fan BHP+.470.

1. BAYLSDR010A Required.

1. Field Supplied Motor Sheave 1VM50 x 7/8 inch, Fan Sheave AK89, and Belt AX40 required

Factory supplied motors, in commercial equipment, are definite purpose motors, specifically designed and tested to operate reliably and continuously at all cataloged conditions. Using the full horsepower range of our fan motors as shown in our tabular data will not result in nuisance tripping or premature motor failure. Our product's warranty will not be affected.



# Performance Data

**Table PD-56— Standard Motor & Sheave/Fan Speed (Rpm)**

Tons	Unit Model No.	6Turns Open	5Turns Open	4Turns Open	3Turns Open	2Turns Open	1Turn Open	Closed
3	T*C036A	N/A	745	819	894	968	1043	1117
4	T*C048A	N/A	833	916	1000	1083	1167	1250
5	T*C060A	N/A	897	987	1077	1166	1256	1346
6	T*C072A	N/A	723	779	835	890	946	1002
7½	TSC090,092A	N/A	835	891	946	1002	1057	1113
8½	T*C102A	N/A	787	847	908	968	1029	1089
10	T*C120A	N/A	908	969	1029	1090	1150	1211

Factory set at 3 turns open.

**Table PD-57— Standard Motor & Low Static Drive Accessory Sheave/Fan Speed (Rpm)**

Tons	Unit Model Number	Drive Accessory Kit	Fan Sheave	5Turns Open	4Turns Open	3Turns Open	2Turns Open	1Turn Open	Closed
3	THC036A	BAYLSDR006A	AK84x3/4"	427	470	512	555	597	640
			AK69x3/4"	522	574	627	679	732	784
4	THC048A	BAYLSDR007A	AK79x3/4"	455	500	546	591	637	682
			AK61x3/4"	593	652	712	771	831	890
5	THC060A	BAYLSDR008A	AK71x3/4"	507	558	609	659	710	761
			AK59x3/4"	614	675	737	798	860	921
7.5	THC092A	BAYLSDR009A	AK99x1"	462	498	533	569	604	640
			AK79x1"	582	627	672	716	761	806
8.5	THC102A	BAYLSDR009A	AK99x1"	462	498	533	569	604	640
			AK79x1"	582	627	672	716	761	806
10	THC120A	BAYLSDR010A	AK94x1"	563	600	638	675	713	750
			AK74x1"	719	767	815	862	910	958

Factory set at 3 turns open.

**Table PD-58— Standard Motor & High Static Drive Accessory Sheave/Fan Speed (Rpm)**

Tons	Unit Model No.	6Turns Open	5Turns Open	4Turns Open	3Turns Open	2Turns Open	1Turn Open	Closed
6	T*C072A3,A4,AW	N/A	831	895	959	1022	1086	1150
6	TSC072AK	N/A	958	1022	1086	1150	1214	1278
7½	TSC090,092A	N/A	958	1022	1086	1150	1214	1278

Factory set at 3 turns open.

**Table PD-59— Oversized Motor & Drive Sheave/Fan Speed (Rpm)**

Tons	Unit Model No.	6Turns Open	5Turns Open	4Turns Open	3Turns Open	2Turns Open	1Turn Open	Closed
6	T*C072A3,A4,AW	N/A	958	1022	1086	1150	1214	1278
7½	TSC090,T*C092A	N/A	1068	1150	1232	1315	1397	1479
8½	T*C102A	N/A	958	1022	1086	1150	1214	1278
10	T*C120A	1050	1135	1200	1275	1350	1425	N/A

Factory set at 3 turns open.

**Table PD-60— Outdoor Sound Power Level - dB (ref. 10<sup>-12</sup> Watts)**

Tons	Unit Model No.	Octave Center Frequency							Overall dBA	
		63.	125	250	500	1000	2000	4000		8000
3	T*C036A	86	83	81	80	78	74	69	68	83
	TSC048A1	92	87	84	83	81	76	72	69	86
4	TSC048A3,A4,AW	90	84	78	77	76	72	70	68	82
	THC048A	92	86	83	82	81	75	72	69	85
5	TSC060A	94	87	83	82	79	75	73	69	84
	THC060A	94	87	82	81	78	74	72	69	84
6	TSC072A	90	94	90	87	83	78	74	67	88
	THC072A	91	95	90	87	84	79	75	68	89
7½	TSC090A	92	95	91	88	84	80	75	68	90
	TSC092A	89	93	88	85	81	76	72	66	87
8½	THC092A	92	96	92	89	85	80	76	69	91
	TSC102A	88	92	87	84	80	75	72	65	86
10	THC102A	91	95	90	87	84	79	75	68	89
	TSC120A	91	88	84	82	81	76	73	67	86
	THC120A	94	89	87	85	84	78	75	69	88

\* Indicates both Standard and High Efficiency.

Note:  
Tests follow ARI270-95.



# Performance Data

**Table PD-61— Static Pressure Drop Through Accessories (Inches Water Column) — 3-10 Tons**

Tons	Unit Model No.	CFM	Standard Filters <sup>1</sup>	Through Reheat Coil (WC)	2 Inch Pleated Filter	Economizer with OA/RA Dampers <sup>2</sup>				Electric Heater Accessory (kW) <sup>3</sup>			54
						100% OA	100% RA	100% OA	100% RA	5-6	9-15	17-36	
						Downflow		Horizontal					
3	TSC036A	960	0.03	—	0.05	0.05	0.01	0.05	0.00	.013	.016	.019	—
		1200	0.04	—	0.07	0.07	0.02	0.07	0.01	.020	.025	.030	—
		1440	0.06	—	0.10	0.10	0.03	0.10	0.01	.029	.036	.043	—
	THC036A	600	0.01	.01	0.03	0.03	0.01	0.03	0.00	—	—	—	—
		960	0.02	.03	0.04	0.05	0.01	0.05	0.00	.013	.016	.019	—
		1200	0.03	.04	0.05	0.07	0.02	0.07	0.01	.020	.025	.030	—
4	TSC048A	1280	0.04	—	0.06	0.08	0.03	0.08	0.01	.023	.029	.034	—
		1600	0.05	—	0.09	0.12	0.04	0.12	0.01	.036	.045	.053	—
		1920	0.08	—	0.12	0.17	0.06	0.17	0.02	.052	.064	.077	—
	THC048A	800	0.02	.02	0.03	0.04	0.01	0.04	0.00	—	—	—	—
		1280	0.04	.05	0.06	0.08	0.03	0.08	0.01	.023	.029	.034	—
		1600	0.05	.07	0.09	0.12	0.04	0.12	0.01	.036	.045	.053	—
5	TSC060A	1600	0.08	.09	0.12	0.17	0.06	0.17	0.02	.052	.064	.077	—
		2000	0.10	—	0.15	0.18	0.04	0.18	0.01	.036	.045	.053	—
		2400	0.15	—	0.22	0.26	0.07	0.26	0.02	.056	.070	.083	—
	THC060A	2400	0.22	—	0.29	0.26	0.10	0.26	0.04	.081	.100	.120	—
		1000	0.02	.03	0.04	0.06	0.01	0.06	0.01	—	—	—	—
		1600	0.04	.07	0.07	0.12	0.04	0.12	0.01	.036	.045	.053	—
6	TSC072A	2000	0.06	.10	0.10	0.18	0.07	0.18	0.02	.056	.070	.083	—
		2400	0.09	.14	0.14	0.26	0.10	0.26	0.04	.081	.100	.120	—
		2880	0.09	—	0.12	0.13	0.04	0.10	0.04	.04	.033	.052	—
	THC072A	1920	0.04	—	0.07	0.10	0.01	0.06	0.02	.02	.011	.021	—
		2400	0.06	—	0.09	0.11	0.02	0.08	0.02	.02	.020	.034	—
		2880	0.09	—	0.12	0.13	0.04	0.10	0.04	.04	.033	.052	—
7½	TSC090,092A	2400	0.06	—	0.09	0.11	0.02	0.08	0.02	.02	.020	.034	—
		3000	0.10	—	0.13	0.14	0.05	0.12	0.05	.05	.042	.063	—
		3600	0.14	—	0.18	0.21	0.07	0.25	0.08	.08	.077	.102	—
	THC092A	1500	0.02	.07	0.03	0.07	0.01	0.04	0.01	—	—	—	—
		2400	0.04	.10	0.06	0.11	0.02	0.08	0.02	.02	.016	.021	—
		3000	0.06	.14	0.09	0.14	0.05	0.12	0.05	.05	.025	.032	—
8½	TSC102A	3600	0.09	.19	0.13	0.21	0.07	0.25	0.08	.08	.036	.046	—
		2720	0.05	—	0.08	0.12	0.03	0.09	0.04	.04	.020	.026	—
		3400	0.08	—	0.11	0.19	0.06	0.18	0.06	.06	.032	.041	—
	THC102A	4080	0.12	—	0.16	0.30	0.07	0.31	0.09	.09	.047	.059	—
		1700	0.02	.08	0.05	0.07	0.01	0.05	0.02	—	—	—	—
		2720	0.05	.12	0.08	0.12	0.03	0.09	0.04	.04	.020	.026	—
10	TSC120A	3400	0.08	—	0.11	0.19	0.06	0.18	0.06	.06	.032	.041	—
		4080	0.12	—	0.16	0.30	0.07	0.31	0.09	.09	.047	.059	—
		4800	0.16	—	0.20	0.34	0.09	0.35	0.10	.10	.065	.081	0.106
	THC120A	3200	0.07	—	0.10	0.17	0.05	0.14	0.05	.05	.028	.036	0.042
		4000	0.11	—	0.15	0.26	0.07	0.30	0.08	.08	.045	.056	0.070
		4800	0.16	—	0.20	0.34	0.09	0.35	0.10	.10	.065	.081	0.106

Notes:  
 1. Tested with standard filters (3-5 tons 1" filters, 6-10 tons 2" filters). Difference in pressure drop should be considered when utilizing optional 2" pleated filters.  
 2. OA = Outside Air and RA = Return Air.  
 3. Nominal kW ratings at 240, 480, 600 volts.

\* Indicates both Standard and High Efficiency.

# Performance Data

**Table PD-62— Auxiliary Electric Heat Capacity**

Tons	Unit Model No.	Total <sup>2</sup>			Stage1		Stage 2	
		kW Input <sup>1</sup>	MBH Output <sup>1</sup>	No. of Stages	kW Input <sup>1</sup>	MBH Output <sup>1</sup>	kW Input <sup>1</sup>	MBH Output <sup>1</sup>
3	T*C036A1	5.00	17.07	1	5.00	17.07	—	—
		10.00	34.14	2	5.00	17.07	5.00	17.07
		13.80	47.11	2	8.80	30.04	5.00	17.07
	T*C036A3, A4, AW	6.00	20.48	1	6.00	20.48	—	—
		12.00	40.97	2	6.00	20.48	6.00	20.48
		17.40	59.40	2	8.70	29.70	8.70	29.69
4	T*C048A1	5.00	17.07	1	5.00	17.07	—	—
		10.00	34.14	2	5.00	17.07	5.00	17.07
		13.80	47.11	2	8.80	30.04	5.00	17.07
	T*C048A3, A4, AW	6.00	20.48	1	6.00	20.48	—	—
		12.00	40.97	2	6.00	20.48	6.00	20.48
		17.40	59.40	2	8.70	29.70	8.70	29.70
5	T*C060A1	5.00	17.07	1	5.00	17.07	—	—
		10.00	34.14	2	5.00	17.07	5.00	17.07
		13.80	47.11	2	8.80	30.04	5.00	17.07
	T*C060A3, A4, AW	6.00	20.48	1	6.00	20.48	—	—
		12.00	40.97	2	6.00	20.48	6.00	20.48
		17.40	59.40	2	8.70	29.70	8.70	29.70
6	TSC060AK	23.00	78.52	2	14.30	48.82	8.70	29.70
		7.50	25.61	2	3.25	11.10	3.25	11.10
		10.90	37.23	2	5.45	18.61	5.45	18.61
	T*C072A3, A4, AW	14.4	49.18	2	7.20	24.59	7.20	24.59
		9.00	30.73	1	9.00	30.73	—	—
		18.00	61.45	1	18.00	61.45	—	—
7½	TSC072AK	27.00	92.18	2	18.00	61.45	9.00	30.73
		36.00	122.90	2	18.00	61.45	18.00	61.45
		11.30	38.60	1	11.30	38.60	—	—
	T*SC090A3, A4, AW	16.90	57.72	2	11.30	38.60	5.60	19.13
		22.60	77.18	2	11.30	38.60	11.30	38.60
		9.00	30.73	1	9.00	30.73	—	—
8½	TSC090AK	18.00	61.45	1	18.00	61.45	—	—
		27.00	92.18	2	18.00	61.45	9.00	30.73
		36.00	122.90	2	18.00	61.45	18.00	61.45
	T*C092A3, A4, AW	11.30	38.60	1	11.30	38.60	—	—
		16.90	57.72	2	11.30	38.60	5.60	19.13
		22.60	77.18	2	11.30	38.60	11.30	38.60
10	T*C102A3, A4, AW	9.00	30.73	1	9.00	30.73	—	—
		18.00	61.45	1	18.00	61.45	—	—
		27.00	92.18	2	18.00	61.45	9.00	30.73
	TSC102AK	36.00	122.90	2	18.00	61.45	18.00	61.45
		16.90	57.72	2	11.30	38.60	5.60	19.13
		22.60	77.18	2	11.30	38.60	11.30	38.60
10	T*C120A3, A4, AW	18.00	61.45	1	18.00	61.45	—	—
		27.00	92.18	2	18.00	61.45	9.00	30.73
		36.00	122.90	2	18.00	61.45	18.00	61.45
	TSC120AK	54.00	184.36	2	36.00	122.90	18.00	61.45
		16.90	57.72	2	11.30	38.60	11.30	38.60
		22.60	77.18	2	11.30	38.60	11.30	38.60
		33.80	115.43	2	22.50	76.84	11.30	38.60

Notes:

1. Does not include indoor fan power or heat.

2. Heaters are rated at 240v, 380v, 480v. and 600v. For other than rated voltage, CAP =  $\left(\frac{\text{Voltage}}{\text{Rated Voltage}}\right)^2 \times \text{rated cap.}$

\* Indicates both Standard and High Efficiency.



# Performance Data

**Table PD-63— Electric Heater Voltage Correction Factors (Applicable to Auxiliary Heat Capacity)**

Nominal Voltage	Distribution Voltage	Capacity Multiplier
240	208	0.751
	230	0.918
	240	1.000
380	380	1.000
480	440	0.840
	460	0.918
	480	1.000
600	540	0.810
	575	0.918
	600	1.000

**Table PD-64 — 3-5 Tons Air Temperature Rise Across Electric Heaters (Degrees F)**

kW	Stages	3Ton 1200 CFM		4Ton 1600 CFM <sup>1</sup>		5Ton 2000 CFM		
		Single Phase	Three Phase	Single Phase	Three Phase	Single Phase	Three Phase	TSC060AK
		T*C036A1	T*C036A3,A4,AW	T*C048A1	T*C048A3,A4,AW	T*C060A1	T*C060A3,A4,AW	TSC060AK
5.00	1	13.2	—	9.9	—	7.9	—	—
6.00	1	—	15.8	—	11.9	—	9.5	—
7.50	2	—	—	—	—	—	—	11.9
10.00	2	26.3	—	19.8	—	15.8	—	—
10.90	2	—	—	—	—	—	—	17.2
12.00	2	—	31.6	—	23.7	—	19.0	—
13.80	2	36.4	—	27.3	—	21.8	—	—
14.40	2	—	—	—	—	—	—	22.8
17.40	2	—	45.8	—	34.4	—	27.5	—
17.60	2	—	—	34.8	—	27.8	—	—
23.00	2	—	—	—	—	—	36.4	—

For minimum design airflow, see airflow performance table for each unit.  
 To calculate temp rise at different air flow, use the following formula: Temp. rise across Electric Heater =  $\frac{kW \times 3414}{1.08 \times CFM}$   
 Note:  
 1. Minimum allowable airflow with a 17.4 or 17.6 KW heater is 1440 cfm.

**Table PD-65 — 6-10 Tons Air Temperature Rise Across Electric Heaters (Degrees F)**

kW	Stages	6Ton 2000 CFM		7½Ton 3000 CFM		8½Ton 3400 CFM <sup>1</sup>		10 Ton 4000 CFM	
		T*C072A3, A4, AW	TSC072AK	T*C092A3, A4, AW	TSC090AK	T*C102A3, A4, AW	TSC102AK	T*C120A3,A4,AW	TSC120AK
		T*C090A3, A4, AW	TSC090AK	T*C102A3, A4, AW	TSC102AK	T*C120A3,A4,AW	TSC120AK	TSC120AK	
9.00	1	14.2	—	9.5	—	8.4	—	—	
11.30	1	—	14.9	—	11.9	—	—	—	
16.90	2	—	22.3	—	17.8	—	15.7	13.4	
18.00	1	28.5	—	19.0	—	16.7	—	14.2	
22.60	2	—	29.8	—	23.8	—	21.0	17.9	
27.00	2	42.7	—	28.5	—	25.1	—	21.3	
33.80	2	—	—	—	—	—	—	—	
36.00	2	56.9	—	37.9	—	33.5	—	28.5	
54.00	2	—	—	—	—	—	—	42.7	

For minimum design airflow, see airflow performance table for each unit.  
 To calculate temp rise at different air flow, use the following formula: Temp. rise across Electric Heater =  $\frac{kW \times 3414}{1.08 \times CFM}$   
 Note:  
 1. Minimum allowable airflow with a 17.4 or 17.6 KW heater is 1440 cfm.

\* Indicates both Standard and High Efficiency.

# Performance Data

**Table PD-66— Hot Gas Reheat Temperature Rise<sup>3</sup>**

		Leaving Evaporator Dry Bulb [F]						
Tons	SCFM	35	40	45	50	55	60	65
3	600	20.3	20.0	19.6	19.2	18.8	18.4	18.0
	720	19.4	19.1	18.7	18.3	17.9	17.6	17.2
	840	18.5	18.2	17.9	17.5	17.1	16.7	16.3
	960	17.6	17.3	17.0	16.6	16.2	15.8	15.5
	1080	16.7	16.4	16.1	15.7	15.4	15.0	14.6
	1200	15.8	15.5	15.2	14.9	14.5	14.1	13.8
	1320	14.9	14.6	14.3	14.0	13.6	13.3	12.9
1440	14.0	13.8	13.5	13.1	12.8	12.4	12.0	
Tons	SCFM	35	40	45	50	55	60	65
4	800	22.0	21.8	21.5	21.2	20.9	20.6	20.3
	960	21.0	20.7	20.5	20.2	19.9	19.6	19.3
	1120	20.0	19.7	19.5	19.2	18.9	18.6	18.2
	1280	19.0	18.7	18.4	18.1	17.9	17.5	17.2
	1440	17.9	17.7	17.4	17.1	16.9	16.5	16.2
	1600	16.9	16.6	16.4	16.1	15.8	15.5	15.2
	1760	15.9	15.6	15.4	15.1	14.8	14.5	14.2
1920	14.8	14.6	14.4	14.1	13.8	13.5	13.2	
Tons	SCFM	35	40	45	50	55	60	65
5	1000	23.7	23.6	23.4	23.2	23.0	22.8	22.5
	1200	22.6	22.4	22.2	22.0	21.8	21.6	21.3
	1400	21.4	21.2	21.0	20.9	20.7	20.4	20.2
	1600	20.3	20.1	19.9	19.7	19.5	19.3	19.0
	1800	19.1	18.9	18.7	18.5	18.4	18.1	17.8
	2000	17.9	17.8	17.6	17.4	17.2	16.9	16.6
	2200	16.8	16.6	16.4	16.2	16.0	15.7	15.4
2400	15.6	15.4	15.2	15.1	14.9	14.6	14.3	
Tons	SCFM	35	40	45	50	55	60	65
7½	1500	22.0	22.9	23.8	24.7	25.6	26.5	27.5
	1800	20.2	21.0	21.9	22.7	23.5	24.4	25.3
	2100	18.5	19.2	19.9	20.7	21.4	22.3	23.1
	2400	16.7	17.3	18.0	18.7	19.3	20.1	20.9
	2700	14.9	15.5	16.1	16.7	17.3	18.0	18.7
	3000	13.1	13.7	14.2	14.7	15.2	15.9	16.5
	3300	11.4	11.8	12.3	12.7	13.1	13.7	14.3
3600	9.6	10.0	10.3	10.7	11.1	11.6	12.2	
Tons	SCFM	35	40	45	50	55	60	65
8½	1700	22.6	23.7	24.9	26.1	27.2	28.3	29.4
	2040	20.6	21.6	22.7	23.7	24.7	25.7	26.6
	2380	18.6	19.5	20.4	21.3	22.2	23.0	23.8
	2720	16.6	17.4	18.2	18.9	19.7	20.3	21.0
	3060	14.7	15.3	15.9	16.6	17.2	17.7	18.1
	3400	12.7	13.2	13.7	14.2	14.7	15.0	15.3
	3740	10.7	11.1	11.4	11.8	12.2	12.3	12.5
4080	8.7	9.0	9.2	9.4	9.6	9.7	9.7	
Tons	SCFM	35	40	45	50	55	60	65
10	2000	26.0	26.5	26.9	27.4	27.9	28.3	28.6
	2400	23.5	24.1	24.7	25.3	25.9	26.4	26.9
	2800	21.1	21.8	22.5	23.3	24.0	24.6	25.1
	3200	18.7	19.5	20.3	21.2	22.0	22.7	23.4
	3600	16.2	17.2	18.1	19.1	20.1	20.8	21.6
	4000	13.8	14.9	15.9	17.0	18.1	19.0	19.8
	4400	11.3	12.5	13.7	14.9	16.1	17.1	18.1
4800	8.9	10.2	11.5	12.9	14.2	15.3	16.3	

Notes:  
 1. Temperature rise does not account for indoor fan heat.  
 2. 70 deg OD Ambient Temperature.  
 3. For units with the Dehumidification (Hot Gas Reheat) option.

# Controls

## ReliaTel™ Controlled Units

**Zone Sensors** are the building occupant's comfort control devices for Precedent™ units with the Micro control:

### Manual Changeover

Heat, Cool or Off System Switch. Fan Auto or Off Switch. One temperature setpoint lever.

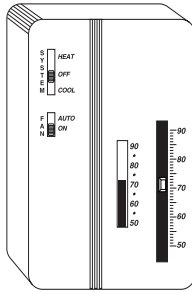

### Manual/Automatic Changeover

Auto, Heat, Cool or Off System Switch. Fan Auto or Off Switch. Two temperature setpoint levers. Optional Status Indication LED lights, System On, Heat, Cool, or Service.

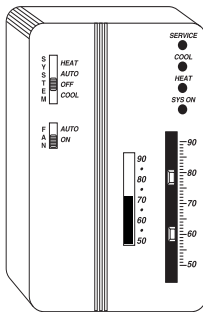

### Remote Sensor

Sensor(s) available for all zone sensors to provide remote sensing capabilities.

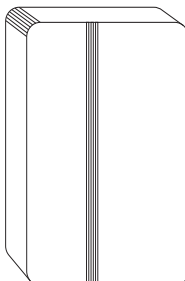

## Integrated Comfort™ System

Sensor(s) available with optional temperature adjustment and override buttons to provide central control through a Trane Integrated Comfort™ system.

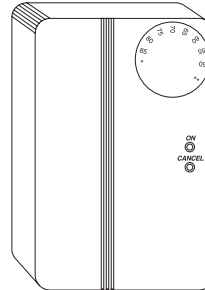

## Dual Thermistor Remote Zone Sensor

This sensor will allow the customer to reduce the total number of remote sensors to obtain space temperature averaging. This sensor should be utilized with ReliaTel controls.

## Digital Display Zone Sensor

The Digital LCD (Liquid Crystal Display) zone sensor has the look and functionality of standard zone sensors. This sensor includes a digital display of set point adjustment and space temperature in F (Fahrenheit) or C (Celsius). Includes FAN and SYSTEM buttons (supports the service functions of the standard sensor). E-squared memory stores last programmed set points. Requires 24 VAC (Volts AC). This sensor should be utilized with ReliaTel™ controls.

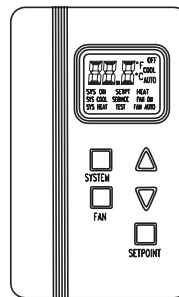

## Programmable Night Setback

Auto or manual changeover with seven-day programming. Keyboard selection of

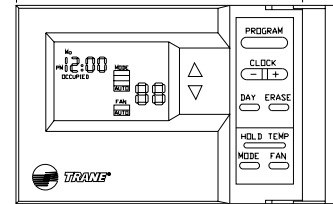

Heat, Cool, Fan, Auto, or On. All programmable sensors have System On, Heat, Cool, Service LED/indicators as standard. Night Setback Sensors have one (1) Occupied, one (1) Un-occupied, and two (2) Override programs per day.

## Humidity Sensor

Field installed, wall-mounted or duct-mounted humidity sensor is used to control activation of the hot gas reheat dehumidification option. The humidity sensor can be set for humidity levels between 40% and 60% relative humidity by adjusting the ReliaTel Options Module.

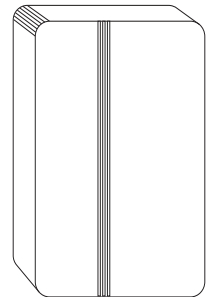

## CO<sub>2</sub> Sensing

The CO<sub>2</sub> sensor shall have the ability to monitor space occupancy levels within the building by measuring the parts per million of CO<sub>2</sub> (Carbon Dioxide) in the air. As the CO<sub>2</sub> levels increase, the outside air damper modulates to meet the CO<sub>2</sub> space ventilation requirements. The CO<sub>2</sub> accessory shall be available as field installed.

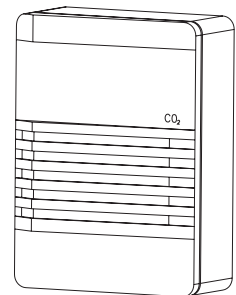

# Controls

---

## Electromechanically Controlled Units

### Conventional Thermostats

The building occupant's comfort control devices for electromechanically controlled units.

### Manual Changeover

One Heat, One Cool Thermostat. Heat, Cool or Off System Switch. Fan Auto or On Switch. Set Point Dial. Adjustable Heat Anticipator.

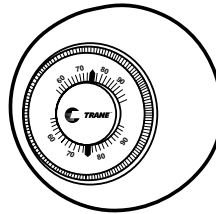

### Automatic Changeover

One Heat, Two Cool Thermostat. Off, Auto System Switch. Auto/On Fan Switch.

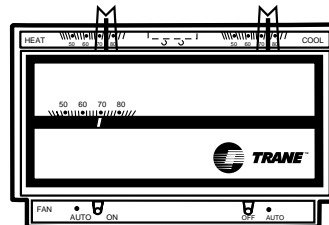

### Programmable Electronic Night Setback Thermostat

Heating setback and cooling setup with 7-day, 5-1-1 programming capability. Available in two heating/cooling or one heating/cooling versions with automatic changeover.

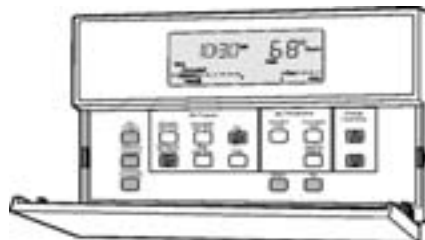



# Electrical Data

# (Standard Efficiency)

**Table ED-1 – Unit Wiring – Standard Efficiency**

Tons	Unit Model No.	Unit Operating Voltage Range	Standard Indoor Fan Motor		Oversize Indoor Fan Motor			Optional Belt Drive Indoor Fan Motor <sup>2</sup>		
			Minimum Circuit Ampacity	Maximum Fuse Size or Maximum Circuit Breaker <sup>1</sup>	Minimum Circuit Ampacity	Maximum Fuse Size or Maximum Circuit Breaker <sup>1</sup>	Minimum Circuit Ampacity	Maximum Fuse Size or Maximum Circuit Breaker <sup>1</sup>	Minimum Circuit Ampacity	Maximum Fuse Size or Maximum Circuit Breaker <sup>1</sup>
3	TSC036A1	187-253	25.3	40	277	40	N/A	N/A		
	TSC036A3	187-253	179	25	20.3	30	20.6	30		
	TSC036A4	414-506	9.2	15	10.4	15	10.6	15		
	TSC036AW	517-633	7.7	15	8.3	15	8.3	15		
4	TSC048A1	187-253	34.0	50	36.1	50	N/A	N/A		
	TSC048A3	187-253	23.9	35	26.0	40	25.3	35		
	TSC048A4	414-506	12.8	20	14.4	20	13.6	20		
	TSC048AW	517-633	9.8	15	10.6	15	10.0	15		
5	TSC060A1	187-253	47.3	60	49.0	60	N/A	N/A		
	TSC060A3	187-253	31.5	50	33.2	50	30.3	45		
	TSC060A4	414-506	16.0	25	16.3	25	15.6	25		
	TSC060AW	517-633	12.2	15	12.8	20	11.8	15		
	TSC060AK	342-418	19.6	30	—	—	—	—		
6	TSC072A3	187-253	32.7	50	34.0	50	—	—		
	TSC072A4	414-506	17.6	25	18.2	25	—	—		
	TSC072AW	517-633	12.8	20	13.6	20	—	—		
	TSC072AK	342-418	23.2	35	—	—	—	—		
7½	TSC090A3	187-253	42.7	60	45.8	60	—	—		
	TSC090A4	414-506	22.6	35	24.1	35	—	—		
	TSC090AW	517-633	17.6	25	18.8	25	—	—		
	TSC090AK	342-418	28.4	40	29.9	45	—	—		
	TSC092A3	187-253	38.9	50	42.0	50	—	—		
8½	TSC092A4	414-506	20.5	25	22.0	25	—	—		
	TSC092AW	517-633	15.5	20	16.7	20	—	—		
	TSC102A3	187-253	45.1	60	48.2	60	—	—		
	TSC102A4	414-506	24.0	30	25.5	35	—	—		
	TSC102AW	517-633	19.5	25	20.7	25	—	—		
10	TSC102AK	342-418	32.6	40	35.6	45	—	—		
	TSC120A3	187-253	52.6	60	56.6	70	—	—		
	TSC120A4	414-506	26.9	35	28.9	35	—	—		
	TSC120AW	517-633	21.8	25	23.5	30	—	—		
	TSC120AK	342-418	32.6	40	35.6	45	—	—		

Notes:

1. HACR breaker per NEC.
2. Optional Belt Drive motor applies to 3-5 ton models only. The standard motor for 6-10 ton models is belt drive.



# Electrical Data

## (High Efficiency)

**Table ED-2 – Unit Wiring – High Efficiency**

Tons	Unit Model No.	Unit Operating Voltage Range	Standard Indoor Fan Motor		Oversize Indoor Fan Motor		Optional Belt Drive Indoor Fan Motor <sup>2</sup>	
			Minimum Circuit Ampacity	Maximum Fuse Size or Maximum Circuit Breaker <sup>1</sup>	Minimum Circuit Ampacity	Maximum Fuse Size or Maximum Circuit Breaker <sup>1</sup>	Minimum Circuit Ampacity	Maximum Fuse Size or Maximum Circuit Breaker <sup>1</sup>
3	THC036A1	187-253	23.9	40	26.3	40	N/A	N/A
	THC036A3	187-253	17.2	25	19.6	30	19.9	30
	THC036A4	414-506	9.0	15	10.2	15	10.4	15
	THC036AW	517-633	7.1	15	7.7	15	7.7	15
4	THC048A1	187-253	29.4	45	31.5	50	N/A	N/A
	THC048A3	187-253	21.2	30	23.3	35	22.6	35
	THC048A4	414-506	11.0	15	12.6	15	11.8	15
	THC048AW	517-633	8.3	15	9.1	15	8.5	15
5	THC060A1	187-253	39.5	60	41.2	60	N/A	N/A
	THC060A3	187-253	30.0	45	31.7	45	28.8	45
	THC060A4	414-506	14.7	20	15.0	20	14.3	20
	THC060AW	517-633	11.8	15	12.4	15	11.4	15
6	THC072A3	187-253	34.8	50	36.1	50	—	—
	THC072A4	414-506	17.5	25	18.1	25	—	—
	THC072AW	517-633	13.5	20	14.3	20	—	—
7½	THC092A3	187-253	38.1	50	41.2	50	—	—
	THC092A4	414-506	19.4	25	20.9	25	—	—
	THC092AW	517-633	14.8	15	16.0	20	—	—
8½	THC102A3	187-253	42.3	50	45.4	60	—	—
	THC102A4	414-506	21.4	25	22.9	30	—	—
	THC102AW	517-633	16.6	20	17.8	20	—	—
10	THC120A3	187-253	48.6	60	52.6	60	—	—
	THC120A4	414-506	25.3	30	27.3	35	—	—
	THC120AW	517-633	19.9	25	21.6	25	—	—

Notes:

1. HACR breaker per NEC.

2. Optional Belt Drive motor applies to 3-5 ton models only. The standard motor for 6-10 ton models is belt drive.



# Electrical Data

(Standard  
Efficiency)

**Table ED-3 — Unit Wiring With Electric Heat (Single Point Connection) — 208/230 Volts — Standard Efficiency**

Tons	To Use With	Heater Model No.	Heater kW Rating <sup>1</sup>	Control Stages	Standard Indoor Motor		Oversize Indoor Motor	
					MCA	Max Fuse Size or Max Circuit Breaker <sup>2</sup>	MCA	Max Fuse Size or Max Circuit Breaker <sup>2</sup>
<b>208/230 Volts Single Phase</b>								
3	TSC036A1	BAYHTRR105A	3.8/5.0	1	25.5/28.9	40/40	28.5/31.9	40/40
		BAYHTRR110A	7.5/10.0	2	48.0/55.0	50/60	51.0/58.0	60/60
		BAYHTRR114A	10.4/13.8	2	65.1/74.8	70/80	68.1/77.8	70/80
4	TSC048A1	BAYHTRR105A	3.8/5.0	1	34.0/34.0	50/50	36.1/36.1	50/50
		BAYHTRR110A	7.5/10.0	2	49.6/56.6	50/60	52.3/59.3	60/60
		BAYHTRR114A	10.4/13.8	2	66.8/76.4	70/80	69.4/79.0	70/80
		BAYHTRR118A	13.2/17.6	2	84.0/96.1	90/100	86.6/98.8	90/100
5	TSC060A1	BAYHTRR105A	3.8/5.0	1	47.3/47.3	60/60	49.0/49.0	60/60
		BAYHTRR110A	7.5/10.0	2	52.9/59.9	60/60	55.0/62.0	60/70
		BAYHTRR114A	10.4/13.8	2	70.0/79.6	80/80	72.1/81.8	80/90
		BAYHTRR118A	13.2/17.6	2	87.3/99.4	90/100	89.4/101.54	90/110
<b>208/230 Volts Three Phase</b>								
3	TSC036A3	BAYHTRR306A	4.5/6.0	1	18.5/20.9	25/25	21.5/23.9	30/30
		BAYHTRR312A	9.0/12.0	2	34.1/39.0	35/40	37.1/42.0	40/45
		BAYHTRR318A	13.1/17.4	2	48.3/55.3	50/60	51.3/58.3	60/60
4	TSC048A3	BAYHTRR306A	4.5/6.0	1	23.9/23.9	35/35	26.0/26.0	40/40
		BAYHTRR312A	9.0/12.0	2	35.8/40.6	40/45	38.4/43.3	40/45
		BAYHTRR318A	13.1/17.4	2	49.9/56.9	50/60	52.5/59.5	60/60
5	TSC060A3	BAYHTRR306A	4.5/6.0	1	31.5/31.5	50/50	33.2/33.2	50/50
		BAYHTRR312A	9.0/12.0	2	39.0/43.9	50/50	41.1/46.0	50/50
		BAYHTRR318A	13.1/17.4	2	53.1/60.1	60/70	55.3/62.3	60/70
		BAYHTRR323A	17.3/23.0	2	67.8/76.9	70/80	69.9/79.0	70/80
6	TSC072A3	BAYHTRS309A	6.8/9.0	1	32.7/33.4	50/50	34.0/35.0	50/50
		BAYHTRS318A	13.5/18.0	1	53.1/60.4	60/70	54.8/62.0	60/70
		BAYHTRS327A	20.3/27.0	2	76.6/87.5	80/90	78.3/89.1	80/90
		BAYHTRS336A	27.0/36.0	2	100.1/114.5	110/125	101.8/116.1	110/125
7½	TSC090A3	BAYHTRS309A	6.8/9.0	1	42.7/42.7	60/60	45.8/45.8	60/60
		BAYHTRS318A	13.5/18.0	1	54.8/62.0	60/70	58.6/65.9	60/70
		BAYHTRS327A	20.3/27.0	2	78.3/89.1	80/90	82.1/93.0	90/100
		BAYHTRS336A	27.0/36.0	2	101.8/116.1	110/125	105.6/120.0	110/125
8½	TSC092A3	BAYHTRS309A	6.8/9.0	1	38.9/38.9	50/50	42.0/42.0	50/50
		BAYHTRS318A	13.5/18.0	1	54.8/62.0	60/70	58.6/65.9	60/70
		BAYHTRS327A	20.3/27.0	2	78.3/89.1	80/90	82.1/93.0	90/100
		BAYHTRS336A	27.0/36.0	2	101.8/116.1	110/125	105.6/120.0	110/125
10	TSC102A3	BAYHTRT309A	6.8/9.0	1	45.1/45.1	60/60	48.2/48.2	60/60
		BAYHTRT318A	13.5/18.0	1	54.8/62.0	60/70	58.6/65.9	60/70
		BAYHTRT327A	20.3/27.0	2	78.3/89.1	80/90	82.1/93.0	90/100
		BAYHTRT336A	27.0/36.0	2	101.8/116.1	110/125	105.6/120.0	110/125
10	TSC120A3	BAYHTRT318A	13.5/18.0	1	58.6/65.9	60/70	63.6/70.9	70/80
		BAYHTRT327A	20.3/27.0	2	82.1/93.0	90/100	87.1/98.0	90/100
		BAYHTRT336A	27.0/36.0	2	105.8/120.0	110/125	110.6/125.0	125/125
		BAYHTRT354A	40.6/54.0	2	152.5/141.7	175/150	157.5/146.7	175/150

Notes:

1. Heater kW ratings are at 208/240 for 208/230V unit.
2. HACR type circuit breaker per NEC.



# Electrical Data

(Standard  
Efficiency)

**Table ED-3 — Unit Wiring With Electric Heat (Single Point Connection)—380, 460 Volts — Standard Efficiency, continued**

Tons	To Use With	Heater Model No.	Heater kW Rating <sup>1</sup>	Control Stages	Standard Indoor Motor		Oversize Indoor Motor	
					MCA	Max Fuse Size or Max Circuit Breaker <sup>2</sup>	MCA	Max Fuse Size or Max Circuit Breaker <sup>2</sup>
<b>380 Volts Three Phase</b>								
5	TSC060AK	BAYHTRR412A	7.5	2	19.6	30	—	—
		BAYHTRR418A	10.9	2	26.1	30	—	—
		BAYHTRR423A	14.4	2	32.8	35	—	—
6	TSC072AK	BAYHTRS418A	11.3	1	27.6	35	—	—
		BAYHTRS427A	16.9	2	38.3	40	—	—
		BAYHTRS436A	22.6	2	49.0	50	—	—
7½	TSC090AK	BAYHTRS418A	11.3	1	28.4	40	29.9	45
		BAYHTRS427A	16.9	2	38.3	40	40.1	45
		BAYHTRS436A	22.6	2	49.0	50	50.9	60
8½	TSC102AK	BAYHTRT427A	16.9	2	38.8	40	40.1	45
		BAYHTRT436A	22.6	2	49.0	50	50.9	60
		BAYHTRT427A	16.9	2	40.1	45	43.6	45
10	TSC120AK	BAYHTRT436A	22.6	2	50.9	60	54.4	60
		BAYHTRT454A	33.8	2	72.3	80	75.8	80
<b>460 Volts Three Phase</b>								
3	TSC036A4	BAYHTRR406A	6.0	1	10.4	15	11.9	15
		BAYHTRR412A	12.0	2	19.4	20	20.9	25
		BAYHTRR418A	17.4	2	27.5	30	29.0	30
4	TSC048A4	BAYHTRR406A	6.0	1	12.8	20	14.4	20
		BAYHTRR412A	12.0	2	20.1	25	22.1	25
		BAYHTRR418A	17.4	2	28.3	30	30.3	35
5	TSC060A4	BAYHTRR406A	6.0	1	16.0	25	16.3	25
		BAYHTRR412A	12.0	2	21.6	25	22.0	25
		BAYHTRR418A	17.4	2	29.8	30	30.1	35
6	TSC072A4	BAYHTRR423A	23.0	2	38.3	40	38.6	40
		BAYHTRS409A	9.0	1	17.6	25	18.2	25
		BAYHTRS418A	18.0	1	30.3	35	31.0	35
7½	TSC090A4	BAYHTRS427A	27.0	2	43.8	45	44.5	45
		BAYHTRS436A	36.0	2	57.3	60	58.0	60
		BAYHTRS409A	9.0	1	22.6	35	24.1	35
8½	TSC102A4	BAYHTRS418A	18.0	1	31.0	35	32.9	35
		BAYHTRS427A	27.0	2	44.5	45	46.4	50
		BAYHTRS436A	36.0	2	58.0	60	59.9	60
10	TSC120A4	BAYHTRS409A	9.0	1	20.5	25	22.0	25
		BAYHTRS418A	18.0	1	31.0	35	32.9	35
		BAYHTRS427A	27.0	2	44.5	45	46.4	50
8½	TSC102A4	BAYHTRS436A	36.0	2	58.0	60	59.9	60
		BAYHTRT409A	9.0	1	24.0	30	25.5	35
		BAYHTRT418A	18.0	1	31.0	35	32.9	35
10	TSC120A4	BAYHTRT427A	27.0	2	44.5	45	46.4	50
		BAYHTRT436A	36.0	2	58.0	60	59.9	60
		BAYHTRT418A	18.0	1	32.9	35	35.4	40
10	TSC120A4	BAYHTRT427A	27.0	2	46.4	50	48.9	50
		BAYHTRT436A	36.0	2	59.9	60	62.4	70
		BAYHTRT454A	54.0	2	70.8	80	73.3	80

Notes:  
 1. Heater kW ratings are at 208/240 for 208/230V, unit.  
 2. HACR type circuit breaker per NEC.



# Electrical Data

(Standard  
Efficiency)

**Table ED-3 — Unit Wiring With Electric Heat (Single Point Connection) — 575 Volts — Standard Efficiency, continued**

Tons	To Use With	Heater Model No.	Heater kW Rating <sup>1</sup>	Control Stages	Standard Indoor Motor		Oversize Indoor Motor	
					MCA	Max Fuse Size or Max Circuit Breaker <sup>2</sup>	MCA	Max Fuse Size or Max Circuit Breaker <sup>2</sup>
<b>575 Volts Three Phase</b>								
3	TSC036AW	BAYHTRRW06A	6.0	1	8.6	15	9.3	15
		BAYHTRRW12A	12.0	2	15.8	20	16.6	20
		BAYHTRRW18A	17.4	2	22.3	25	23.1	25
4	TSC048AW	BAYHTRRW06A	6.0	1	9.8	15	10.6	15
		BAYHTRRW12A	12.0	2	16.3	20	17.3	20
		BAYHTRRW18A	17.4	2	22.8	25	23.8	25
5	TSC060AW	BAYHTRRW06A	6.0	1	12.2	15	12.8	20
		BAYHTRRW12A	12.0	2	17.1	20	17.8	20
		BAYHTRRW18A	17.4	2	23.6	25	24.3	25
		BAYHTRRW23A	23.0	2	30.3	35	31.0	35
6	TSC072AW	BAYHTRSW09A	9.0	1	13.0	20	14.0	20
		BAYHTRSW18A	18.0	1	23.8	25	24.8	25
		BAYHTRSW27A	27.0	2	34.6	35	35.6	40
	TSC090AW	BAYHTRSW36A	36.0	2	45.4	50	46.4	50
		BAYHTRSW09A	9.0	1	17.6	25	18.8	25
7½	TSC092AW	BAYHTRSW18A	18.0	1	24.8	25	26.3	30
		BAYHTRSW27A	27.0	2	35.6	40	37.1	40
		BAYHTRSW36A	36.0	2	46.4	50	47.9	50
		BAYHTRSW09A	9.0	1	15.5	20	16.7	20
8½	TSC102AW	BAYHTRTW18A	18.0	1	24.8	25	26.3	30
		BAYHTRTW27A	27.0	2	35.6	40	37.1	40
		BAYHTRTW36A	36.0	2	46.4	50	47.9	50
10	TSC120AW	BAYHTRTW18A	18.0	1	26.3	30	28.4	30
		BAYHTRTW27A	27.0	2	37.1	40	39.3	40
		BAYHTRTW36A	36.0	2	47.9	50	50.0	50
		BAYHTRTW54A	54.0	2	56.6	60	58.8	70

Notes:

1. Heater kW ratings are at 208/240 for 208/230V unit.
2. HACR type circuit breaker per NEC.



# Electrical Data

# (Standard Efficiency)

**Table ED-4 — Unit Wiring With Electric Heat (Single Point Connection) — Optional Belt Drive — Standard Efficiency**

Tons	To Use With	Heater Model No.	Heater kW Rating <sup>1</sup>	Control Stages	Optional Belt Drive Indoor Motor	
					MCA	Max Fuse Size or Max Circuit Breaker <sup>2</sup>
<b>208/230 Volts Single Phase</b>						
3	TSC036A1	BAYHTRR105A	N/A	N/A	N/A	N/A
		BAYHTRR110A	N/A	N/A	N/A	N/A
		BAYHTRR114A	N/A	N/A	N/A	N/A
4	TSC048A1	BAYHTRR105A	N/A	N/A	N/A	N/A
		BAYHTRR110A	N/A	N/A	N/A	N/A
		BAYHTRR114A	N/A	N/A	N/A	N/A
		BAYHTRR118A	N/A	N/A	N/A	N/A
5	TSC060A1	BAYHTRR105A	N/A	N/A	N/A	N/A
		BAYHTRR110A	N/A	N/A	N/A	N/A
		BAYHTRR114A	N/A	N/A	N/A	N/A
		BAYHTRR118A	N/A	N/A	N/A	N/A
<b>208/230 Volts Three Phase</b>						
3	TSC036A3	BAYHTRR306A	4.5/6.0	1	21.9/24.3	30/30
		BAYHTRR312A	9.0/12.0	2	37.5/42.4	40/45
		BAYHTRR318A	13.1/17.4	2	51.6/58.6	60/60
4	TSC048A3	BAYHTRR306A	4.5/6.0	1	25.3/25.3	35/35
		BAYHTRR312A	9.0/12.0	2	37.5/42.4	40/45
		BAYHTRR318A	13.1/17.4	2	51.6/58.6	60/60
		BAYHTRR306A	4.5/6.0	1	30.3/30.3	45/45
5	TSC060A3	BAYHTRR312A	9.0/12.0	2	37.5/42.4	45/45
		BAYHTRR318A	13.1/17.4	2	51.6/58.6	60/60
		BAYHTRR323A	17.3/23.0	2	66.3/75.4	70/80
		BAYHTRR306A	4.5/6.0	1	30.3/30.3	45/45
<b>460 Volts Three Phase</b>						
3	TSC036A4	BAYHTRR406A	6.0	1	12.1	15
		BAYHTRR412A	12.0	2	21.1	25
		BAYHTRR418A	17.4	2	29.3	30
4	TSC048A4	BAYHTRR406A	6.0	1	13.6	20
		BAYHTRR412A	12.0	2	21.1	25
		BAYHTRR418A	17.4	2	29.3	30
		BAYHTRR406A	6.0	1	15.6	25
5	TSC060A4	BAYHTRR412A	12.0	2	21.1	25
		BAYHTRR418A	17.4	2	29.3	30
		BAYHTRR423A	23.0	2	37.8	40
		BAYHTRR406A	6.0	1	9.3	15
<b>575 Volts Three Phase</b>						
3	TSC036AW	BAYHTRRW06A	6.0	1	9.3	15
		BAYHTRRW12A	12.0	2	16.6	20
		BAYHTRRW18A	17.4	2	23.1	25
4	TSC048AW	BAYHTRRW06A	6.0	1	10.0	15
		BAYHTRRW12A	12.0	2	16.6	20
		BAYHTRRW18A	17.4	2	23.1	25
		BAYHTRRW06A	6.0	1	11.8	15
5	TSC060AW	BAYHTRRW12A	12.0	2	16.6	20
		BAYHTRRW18A	17.4	2	23.1	25
		BAYHTRRW23A	23.0	2	29.8	30
		BAYHTRRW06A	6.0	1	11.8	15

Notes:

1. Heater kW ratings are at 208/240 for 208/230V unit.
2. HACR type circuit breaker per NEC.



# Electrical Data

(High  
Efficiency)

**Table ED-5 — Unit Wiring With Electric Heat (Single Point Connection) — 208/230 Volts — High Efficiency**

Tons	To Use With	Heater Model No.	Heater kW Rating <sup>1</sup>	Control Stages	Standard Indoor Motor		Oversize Indoor Motor	
					MCA	Max Fuse Size or Max Circuit Breaker <sup>2</sup>	MCA	Max Fuse Size or Max Circuit Breaker <sup>2</sup>
<b>208/230 Volts Single Phase</b>								
3	THC036A1	BAYHTRR105A	3.8/5.0	1	25.5/28.9	40/40	28.5/31.9	40/40
		BAYHTRR110A	7.5/10.0	2	48.0/55.0	50/60	51.0/58.0	60/60
		BAYHTRR114A	10.4/13.8	2	65.1/74.8	70/80	68.1/77.8	70/80
4	THC048A1	BAYHTRR105A	3.8/5.0	1	29.4/30.5	45/45	31.5/33.1	50/50
		BAYHTRR110A	7.5/10.0	2	49.6/56.6	50/60	52.3/59.3	60/60
		BAYHTRR114A	10.4/13.8	2	66.8/76.4	70/80	69.4/79.0	70/80
5	THC060A1	BAYHTRR118A	13.2/17.6	2	84.0/96.1	90/100	86.6/98.8	90/100
		BAYHTRR105A	3.8/5.0	1	39.5/39.5	60/60	41.2/41.2	60/60
		BAYHTRR110A	7.5/10.0	2	52.9/59.9	60/60	55.0/62.0	60/70
6	THC072A3	BAYHTRR114A	10.4/13.8	2	70.0/79.6	80/80	72.1/81.8	80/90
		BAYHTRR118A	13.2/17.6	2	87.3/99.4	90/100	89.4/101.5	90/100
		BAYHTRR105A	3.8/5.0	1	39.5/39.5	60/60	41.2/41.2	60/60
<b>208/230 Volts Three Phase</b>								
3	THC036A3	BAYHTRR306A	4.5/6.0	1	18.5/20.9	30/30	21.5/23.9	30/30
		BAYHTRR312A	9.0/12.0	2	34.1/39.0	35/40	37.1/42.0	40/45
		BAYHTRR318A	13.1/17.4	2	48.3/55.3	50/60	51.3/58.3	60/60
4	THC048A3	BAYHTRR306A	4.5/6.0	1	21.2/22.5	30/30	23.3/25.1	35/35
		BAYHTRR312A	9.0/12.0	2	35.8/40.6	40/45	38.4/43.3	40/45
		BAYHTRR318A	13.1/17.4	2	49.9/56.9	50/60	52.5/59.5	60/60
5	THC060A3	BAYHTRR306A	4.5/6.0	1	30.0/30.0	45/45	31.7/31.7	45/45
		BAYHTRR312A	9.0/12.0	2	39.0/43.9	45/45	41.1/46.0	45/50
		BAYHTRR318A	13.1/17.4	2	53.1/60.1	60/70	55.3/62.3	60/70
6	THC072A3	BAYHTRR323A	17.3/23.0	2	67.8/76.9	70/80	69.9/79.0	70/80
		BAYHTRS309A	6.8/9.0	1	34.8/34.8	50/50	35.7/35.7	50/50
		BAYHTRS318A	13.5/18.0	1	53.1/60.4	60/70	54.8/62.0	60/70
7½	THC092A3	BAYHTRS327A	20.3/27.0	2	76.6/87.5	80/90	78.3/89.1	80/90
		BAYHTRS336A	27.0/36.0	2	100.1/114.5	110/125	101.8/116.1	110/125
		BAYHTRT309A	6.8/9.0	1	38.1/38.1	50/50	44.2/44.2	50/50
8½	THC102A3	BAYHTRT318A	13.5/18.0	1	54.8/62.0	60/70	58.6/65.9	60/70
		BAYHTRT327A	20.3/27.0	2	78.3/89.1	80/90	82.1/93.0	90/100
		BAYHTRT336A	27.0/36.0	2	101.8/116.1	110/125	105.6/120.0	110/125
10	THC120A3	BAYHTRT309A	6.8/9.0	1	42.3/42.3	50/50	44.2/44.2	50/50
		BAYHTRT318A	13.5/18.0	1	54.8/62.0	60/70	58.6/65.9	60/70
		BAYHTRT327A	20.3/27.0	2	78.3/89.1	80/90	82.1/93.0	90/100
10	THC120A3	BAYHTRT336A	27.0/36.0	2	101.8/116.1	110/125	105.6/120.0	110/125
		BAYHTRT318A	13.5/18.0	1	58.6/65.9	60/70	63.6/70.9	70/80
		BAYHTRT327A	20.3/27.0	2	82.1/93.0	90/100	87.1/98.0	90/100
10	THC120A3	BAYHTRT336A	27.0/36.0	2	105.6/120.0	110/125	110.6/125.0	125/125
		BAYHTRT354A	40.6/54.0	2	152.5/141.7	175/150	157.5/146.7	175/150

Notes:  
 1. Heater kW ratings are at 208/240 for 208/230V unit.  
 2. HACR type circuit breaker per NEC.



# Electrical Data

(High  
Efficiency)

**Table ED-5 — Unit Wiring With Electric Heat (Single Point Connection) — 460 Volts — High Efficiency, continued**

Tons	To Use With	Heater Model No.	Heater kW Rating <sup>1</sup>	Control Stages	Standard Indoor Motor		Oversize Indoor Motor	
					MCA	Max Fuse Size or Max Circuit Breaker <sup>2</sup>	MCA	Max Fuse Size or Max Circuit Breaker <sup>2</sup>
<b>460 Volts Three Phase</b>								
3	THC036A4	BAYHTRR406A	6.0	1	10.4	15	11.9	15
		BAYHTRR412A	12.0	2	19.4	20	20.9	25
		BAYHTRR418A	17.4	2	27.5	30	29.9	30
4	THC048A4	BAYHTRR406A	6.0	1	11.1	15	13.1	15
		BAYHTRR412A	12.0	2	20.1	25	22.1	25
		BAYHTRR418A	17.4	2	28.3	30	30.3	35
5	THC060A4	BAYHTRR406A	6.0	1	14.7	20	15.0	20
		BAYHTRR412A	12.0	2	21.6	25	22.0	25
		BAYHTRR418A	17.4	2	29.8	30	30.1	35
		BAYHTRR423A	23.0	2	38.3	40	38.6	40
6	THC072A4	BAYHTRS409A	9.0	1	17.5	25	18.1	25
		BAYHTRS418A	18.0	1	30.3	35	31.0	35
		BAYHTRS427A	27.0	2	43.8	45	44.5	45
		BAYHTRS436A	36.0	2	57.3	60	58.0	60
7½	THC092A4	BAYHTRT409A	9.0	1	19.4	25	20.9	25
		BAYHTRT418A	18.0	1	31.0	35	32.9	35
		BAYHTRT427A	27.0	2	44.5	45	46.4	50
		BAYHTRT436A	36.0	2	58.0	60	59.9	60
8½	THC102A4	BAYHTRT409A	9.0	1	21.4	25	22.9	30
		BAYHTRT418A	18.0	1	31.0	35	32.9	35
		BAYHTRT427A	27.0	2	44.5	45	46.4	50
		BAYHTRT436A	36.0	2	58.0	60	59.9	60
10	THC120A4	BAYHTRT418A	18.0	1	32.9	35	35.4	40
		BAYHTRT427A	27.0	2	46.4	50	48.9	50
		BAYHTRT436A	36.0	2	59.9	60	62.4	70
		BAYHTRT454A	54.0	2	70.8	80	73.3	80

Notes:

1. Heater kW ratings are at 208/240 for 208/230V unit.
2. HACR type circuit breaker per NEC.



# Electrical Data

(High  
Efficiency)

**Table ED-5 — Unit Wiring With Electric Heat (Single Point Connection) — 575 Volts — High Efficiency, continued**

Tons	To Use With	Heater Model No.	Heater kW Rating <sup>1</sup>	Control Stages	Standard Indoor Motor		Oversize Indoor Motor	
					MCA	Max Fuse Size or Max Circuit Breaker <sup>2</sup>	MCA	Max Fuse Size or Max Circuit Breaker <sup>2</sup>
<b>575 Volts Three Phase</b>								
3	THC036AW	BAYHTRRW06A	6.0	1	8.6	15	9.3	15
		BAYHTRRW12A	12.0	2	15.8	20	16.6	20
		BAYHTRRW18A	17.4	2	22.3	25	23.1	25
4	THC048AW	BAYHTRRW06A	6.0	1	9.1	15	10.1	15
		BAYHTRRW12A	12.0	2	16.3	20	17.3	20
		BAYHTRRW18A	17.4	2	22.8	25	23.8	25
5	THC060AW	BAYHTRRW06A	6.0	1	11.8	15	12.4	15
		BAYHTRRW12A	12.0	2	17.1	20	17.8	20
		BAYHTRRW18A	17.4	2	23.6	25	24.3	25
		BAYHTRRW23A	23.0	2	30.3	35	31.0	35
6	THC072AW	BAYHTRSW09A	9.0	1	13.5	20	14.3	20
		BAYHTRSW18A	18.0	1	23.8	25	24.8	25
		BAYHTRSW27A	27.0	2	34.6	35	35.6	40
		BAYHTRSW36A	36.0	2	45.4	50	46.4	50
7½	THC092AW	BAYHTRTW18A	18.0	1	24.8	25	26.3	30
		BAYHTRTW27A	27.0	2	35.6	40	37.1	40
		BAYHTRTW36A	36.0	2	46.4	50	47.9	50
8½	THC102AW	BAYHTRTW18A	18.0	1	24.8	25	26.3	30
		BAYHTRTW27A	27.0	2	35.6	40	37.1	40
		BAYHTRTW36A	36.0	2	46.4	50	47.9	50
10	THC120AW	BAYHTRTW18A	18.0	1	26.3	30	28.4	30
		BAYHTRTW27A	27.0	2	37.1	40	39.3	40
		BAYHTRTW36A	36.0	2	47.9	50	50.0	50
		BAYHTRTW54A	54.0	2	56.6	60	58.8	70

Notes:

1. Heater kW ratings are at 208/240 for 208/230V unit.
2. HACR type circuit breaker per NEC.





# Electrical Data

(High  
Efficiency)

**Table ED-6 — Unit Wiring With Electric Heat (Single Point Connection) — Optional Belt Drive — High Efficiency**

Tons	To Use With	Heater Model No.	Heater kW Rating <sup>1</sup>	Control Stages	Belt Drive Indoor Motor	
					MCA	Max Fuse Size or Max Circuit Breaker <sup>2</sup>
<b>208/230 Volts Single Phase</b>						
3	THC036A1	BAYHTRR105A	N/A	N/A	N/A	N/A
		BAYHTRR110A	N/A	N/A	N/A	N/A
		BAYHTRR114A	N/A	N/A	N/A	N/A
4	THC048A1	BAYHTRR105A	N/A	N/A	N/A	N/A
		BAYHTRR110A	N/A	N/A	N/A	N/A
		BAYHTRR114A	1N/A	N/A	N/A	N/A
		BAYHTRR118A	N/A	N/A	N/A	N/A
5	THC060A1	BAYHTRR105A	N/A	N/A	N/A	N/A
		BAYHTRR110A	N/A	N/A	N/A	N/A
		BAYHTRR114A	N/A	N/A	N/A	N/A
		BAYHTRR118A	N/A	N/A	N/A	N/A
<b>208/230 Volts Three Phase</b>						
3	THC036A3	BAYHTRR306A	4.5/6.0	1	21.9/24.3	25/25
		BAYHTRR312A	9.0/12.0	2	37.5/42.4	40/45
		BAYHTRR318A	13.1/17.4	2	51.6/58.6	60/60
4	THC048A3	BAYHTRR306A	4.5/6.0	1	22.6/24.3	35/35
		BAYHTRR312A	9.0/12.0	2	37.5/42.4	40/45
		BAYHTRR318A	13.1/17.4	2	51.6/58.6	60/60
5	THC060A3	BAYHTRR306A	4.5/6.0	1	28.8/28.8	45/45
		BAYHTRR312A	9.0/12.0	2	37.5/42.4	45/45
		BAYHTRR318A	13.1/17.4	2	51.6/58.6	60/60
		BAYHTRR323A	17.3/23.0	2	66.3/75.4	70/80
<b>460 Volts Three Phase</b>						
3	THC036A4	BAYHTRR406A	6.0	1	12.1	15
		BAYHTRR412A	12.0	2	21.1	25
		BAYHTRR418A	17.4	2	29.3	30
4	THC048A4	BAYHTRR406A	6.0	1	12.1	15
		BAYHTRR412A	12.0	2	21.1	25
		BAYHTRR418A	17.4	2	29.3	30
5	THC060A4	BAYHTRR406A	6.0	1	14.3	20
		BAYHTRR412A	12.0	2	21.1	25
		BAYHTRR418A	17.4	2	29.3	30
		BAYHTRR423A	23.0	2	37.8	40
<b>575 Volts Three Phase</b>						
3	THC036AW	BAYHTRRW06A	6.0	1	9.3	15
		BAYHTRRW12A	12.0	2	16.6	20
		BAYHTRRW18A	17.4	2	23.1	25
4	THC048AW	BAYHTRRW06A	6.0	1	9.3	15
		BAYHTRRW12A	12.0	2	16.6	20
		BAYHTRRW18A	17.4	2	23.1	25
5	THC060AW	BAYHTRRW06A	6.0	1	11.4	15
		BAYHTRRW12A	12.0	2	16.6	20
		BAYHTRRW18A	17.4	2	23.1	25
		BAYHTRRW23A	23.0	2	29.8	30

Notes:

1. Heater kW ratings are at 208/240 for 208/230V unit.
2. HACR type circuit breaker per NEC.



# Electrical Data

**Table ED-7 – Electrical Characteristics – Evaporator Fan Motor – 60 Cycle – Standard and Oversized**

Tons	Unit Model No.	Standard Evaporator Fan Motor						Oversized Evaporator Fan Motor					
		No.	Volts	Phase	HP	Amps		No.	Volts	Phase	HP	Amps	
						FLA	LRA					FLA	LRA
3	T*C036A1	1	208-230	1	.33	2.30	3.90	1	208-230	1	.50	4.70	9.80
	T*C036A3	1	208-230	1	.33	2.30	3.90	1	208-230	1	.50	4.70	9.80
	T*C036A4	1	460	1	.33	1.10	2.00	1	460	1	.50	2.30	5.20
	T*C036AW	1	575	1	.33	1.10	1.80	1	460	1	.50	1.70	3.60
4	T*C048A1	1	208-230	1	.60	3.60	6.60	1	208-230	1	.80	5.70	13.60
	T*C048A3	1	208-230	1	.60	3.60	6.60	1	208-230	1	.80	5.70	13.60
	T*C048A4	1	460	1	.60	1.70	2.80	1	460	1	.80	3.30	7.20
	T*C048AW	1	575	1	.60	1.50	2.40	1	575	1	.80	2.30	5.80
5	T*C060A1	1	208-230	1	.90	6.20	14.0	1	208-230	1	1.00	7.90	16.40
	T*C060A3	1	208-230	1	.90	6.20	14.0	1	208-230	1	1.00	7.90	16.40
	T*C060A4	1	460	1	.90	2.90	6.60	1	460	1	1.00	3.2	8.20
	T*C060AW	1	575	1	.90	2.10	4.90	1	575	1	1.00	2.4	5.00
6	TSC060AK	1	380	1	1.00	4.3	8.3	—	—	—	—	—	—
	T*C072A3	1	208-230	3	1.00	5.00	32.20	1	208-230	3	2.00	6.30	48.00
	T*C072A4	1	460	3	1.00	2.50	16.10	1	460	3	2.00	3.10	24.00
	T*C072AW	1	575	3	1.00	1.70	13.20	1	575	3	2.00	2.50	18.20
7½	TSC072AK	1	380	3	2.0	4.9	35.0	—	—	—	—	—	—
	T*C090A3	1	208-230	3	2.00	6.30	48.00	1	208-230	3	3.00	9.40	83.00
	T*C090A4	1	460	3	2.00	3.10	24.00	1	460	3	3.00	4.60	42.00
	T*C090AW	1	575	3	2.00	2.50	18.20	1	575	3	3.00	3.70	31.00
8½	TSC090AK	1	380	3	2.0	4.9	35.0	1	380	3	3.0	6.4	51.1
	T*C092A3	1	208-230	3	2.00	6.30	48.00	1	208-230	3	3.00	9.40	83.00
	T*C092A4	1	460	3	2.00	3.10	24.00	1	460	3	3.00	4.60	42.00
	T*C092AW	1	575	3	2.00	2.50	18.20	1	575	3	3.00	3.70	31.00
10	T*C102A3	1	208-230	3	2.00	6.30	48.00	1	208-230	3	3.00	9.40	83.00
	T*C102A4	1	460	3	2.00	3.10	24.00	1	460	3	3.00	4.60	42.00
	T*C102AW	1	575	3	2.00	2.50	18.20	1	575	3	3.00	3.70	31.00
	TSC102AK	1	380	3	2.0	4.9	35.0	1	380	3	3.0	6.4	51.1
10	T*C120A3	1	208-230	3	3.00	9.40	83.00	1	208-230	3	5.00	13.40	112.00
	T*C120A4	1	460	3	3.00	4.60	42.00	1	460	3	5.00	6.60	56.00
	T*C120AW	1	575	3	3.00	3.70	31.00	1	575	3	5.00	5.40	44.0
	TSC120AK	1	380	3	3.0	6.4	51.1	1	380	3	5.0	10.8	66.5

**Table ED-8 – Electrical Characteristics – Evaporator Fan Motor – 60 Cycle – Optional Belt Drive**

Tons	Unit Model No.	No.	Volts	Phase	HP	Amps	
						FLA	LRA
3	T*C036A3	1	208-230	3	1.00	5.00	32.20
	T*C036A4	1	460	3	1.00	2.50	16.10
	T*C036AW	1	575	3	1.00	1.70	13.20
4	T*C048A3	1	208-230	3	1.00	5.00	32.20
	T*C048A4	1	460	3	1.00	2.50	16.10
	T*C048AW	1	575	3	1.00	1.70	13.20
5	T*C060A3	1	208-230	3	1.00	5.00	32.20
	T*C060A4	1	460	3	1.00	2.50	16.10
	T*C060AW	1	575	3	1.00	1.70	13.20

\* Indicates both Standard and High Efficiency.



# Electrical Data

(Standard  
Efficiency)

**Table ED-9— Electrical Characteristics – Compressor Motor And Condenser Motor – 60 Cycle – Standard Efficiency**

Tons	Unit Model No.	No.	Compressor Motors						Condenser Fan Motors				
			Volts	Phase	HP <sup>2</sup>	RPM	Amps <sup>1</sup>		No.	Phase	HP	Amps	
							RLA	LRA				FLA	LRA
3	TSC036A1	1	208-230	1	3.1	3450	172	104.0	1	1	.20	1.5	2.5
	TSC036A3	1	208-230	3	3.1	3450	11.3	74.0	1	1	.20	1.5	2.5
	TSC036A4	1	460	3	3.1	3450	6.0	37.6	1	1	.20	.6	1.3
	TSC036AW	1	575	3	3.1	3450	4.9	30.4	1	1	.20	.5	1.2
4	TSC048A1	1	208-230	1	3.9	3450	22.7	131.0	1	1	.33	2.0	6.6
	TSC048A3	1	208-230	3	3.9	3450	14.6	91.0	1	1	.33	2.0	6.6
	TSC048A4	1	460	3	3.9	3450	7.9	46.0	1	1	.33	1.2	2.5
	TSC048AW	1	575	3	3.9	3450	6.1	37.0	1	1	.33	.7	1.5
5	TSC060A1	1	208-230	1	5.1	3450	31.3	144.0	1	1	.33	2.0	6.6
	TSC060A3	1	208-230	3	5.1	3450	18.6	128.0	1	1	.33	2.0	6.6
	TSC060A4	1	460	3	5.1	3450	9.5	63.0	1	1	.33	1.2	2.5
	TSC060AW	1	575	3	5.1	3450	7.5	49.0	1	1	.33	.7	1.5
	TSC060AK	1	380	3	5.1	3450	11.4	64	1	1	.40	1.1	4.3
6	TSC072A3	1	208-230	3	6	3450	19.0	156	1	1	.70	3.85	9.30
	TSC072A4	1	460	3	6	3450	10.1	75	1	1	.70	2.50	5.80
	TSC072AW	1	575	3	6	3450	7.7	54	1	1	.70	1.54	3.60
	TSC072AK	1	380	3	6	3450	12.2	70	1	1	.75	2.5	7.7
7½	TSC090A3	1	208-230	3	7.5	3450	26.0	181.5	1	1	.70	3.85	9.30
	TSC090A4	1	460	3	7.5	3450	13.6	95.0	1	1	.70	2.50	5.80
	TSC090AW	1	575	3	7.5	3450	10.9	69.0	1	1	.70	1.54	3.60
	TSC090AK	1	380	3	7.5	3450	16.4	106.3	1	1	.75	2.5	7.7
	TSC092A3	2	208-230	3	4/2.8	3450	14.7/10.3	91/77	1	1	.70	3.85	9.30
8½	TSC092A4	2	460	3	4/2.8	3450	7.6/5.4	50/39	1	1	.70	2.50	5.80
	TSC092AW	2	575	3	4/2.8	3450	5.8/4.2	37/31	1	1	.70	1.54	3.60
	TSC102A3	2	208-230	3	5.1/2.8	3450	18.6/10.3	128/77	1	1	.75	4.0	9.4
	TSC102A4	2	460	3	5.1/2.8	3450	10.0/5.4	63/39	1	1	.75	2.8	6.8
10	TSC102AW	2	575	3	5.1/2.8	3450	8.2/4.2	49/31	1	1	.75	2.4	6.2
	TSC102AK	1	380	3	5.1/2.8	3450	12.1/6.6	64/39	1	1	.75	2.5	7.7
	TSC120A3	2	208-230	3	5.1/3.9	3450	18.6/14.7	128/91	1	1	.75	4.0	9.4
	TSC120A4	2	460	3	5.1/3.9	3450	9.5/7.4	63/46	1	1	.75	2.8	6.8
10	TSC120AW	2	575	3	5.1/3.9	3450	7.8/5.8	49/37	1	1	.75	2.4	6.2
	TSC120AK	1	380	3	5.1/3.9	3450	11.5/9.0	64/54	1	1	.75	2.5	7.7

Notes:

1. Amp draw for each motor; multiply value by number of motors to determine total amps.
2. HP for each compressor.



# Electrical Data

**Table ED-10 – Electrical Characteristics – Compressor Motor And Condenser Motor – 60 Cycle – High Efficiency**

Tons	Unit Model No.	No.	Compressor Motors					Condenser Fan Motors					
			Volts	Phase	HP <sup>2</sup>	RPM	Amps <sup>1</sup>		No.	Phase	HP	Amps <sup>1</sup>	
							RLA	LRA				FLA	LRA
3	THC036A1	1	208-230	1	2.8	3450	16.1	88.0	1	1	.20	1.5	2.5
	THC036A3	1	208-230	3	2.8	3450	10.7	77.0	1	1	.20	1.5	2.5
	THC036A4	1	460	3	2.8	3450	5.8	39.0	1	1	.20	0.6	1.3
	THC036AW	1	575	3	2.8	3450	4.4	31.0	1	1	.20	0.5	1.2
4	THC048A1	1	208-230	1	3.5	3450	19.0	109.0	1	1	.33	2.0	6.6
	THC048A3	1	208-230	3	3.5	3450	12.5	88.0	1	1	.33	2.0	6.6
	THC048A4	1	460	3	3.5	3450	6.5	44.0	1	1	.33	1.2	2.5
	THC048AW	1	575	3	3.5	3450	4.9	34.0	1	1	.33	0.7	1.5
5	THC060A1	1	208-230	1	4.5	3450	25.0	169.0	1	1	.33	2.0	6.6
	THC060A3	1	208-230	3	4.5	3450	17.4	124.0	1	1	.33	2.0	6.6
	THC060A4	1	460	3	4.5	3450	7.8	59.6	1	1	.33	1.2	2.5
	THC060AW	1	575	3	4.5	3450	6.2	49.4	1	1	.33	0.9	1.5
6	THC072A3	1	208-230	3	5.7	3450	20.7	156	1	1	.70	3.85	9.30
	THC072A4	1	460	3	5.7	3450	10	75	1	1	.70	2.50	5.80
	THC072AW	1	575	3	5.7	3450	8.2	54	1	1	.70	1.54	3.60
7½	THC092A3	2	208-230	3	3.5/3.3	3450	12.4/12.4	88/88	1	1	.70	3.85	9.30
	THC092A4	2	460	3	3.5/3.3	3450	6.4/5.8	44/44	1	1	.70	2.50	5.80
	THC092AW	2	575	3	3.5/3.3	3450	4.8/4.8	34/34	1	1	.70	1.54	3.60
8½	THC102A3	2	208-230	3	3.9/3.5	3450	14.7/12.4	91/88	1	1	.75	4.0	9.4
	THC102A4	2	460	3	3.9/3.5	3450	7.1/6.4	50/44	1	1	.75	2.8	6.8
	THC102AW	2	575	3	3.9/3.5	3450	5.4/4.8	37/34	1	1	.75	2.4	6.2
10	THC120A3	2	208-230	3	4.8/3.5	3450	17.3/12.4	124/88	1	1	.75	4.0	9.4
	THC120A4	2	460	3	4.8/3.5	3450	9.0/6.4	59.6/44	1	1	.75	2.8	6.8
	THC120AW	2	575	3	4.8/3.5	3450	7.1/4.8	49.4/34	1	1	.75	2.4	6.2

Notes:

1. Amp draw for each motor; multiply value by number of motors to determine total amps.
2. HP for each compressor.

**Table ED-11 – Electrical Characteristics – Power Exhaust**

Tons	Volts	Phase	HP	RPM <sup>1</sup>	FLA	LRA
6-10	208-230	1	0.87	1075	5.7	16.3
6-10	460	1	0.87	1075	3.3	6.8
6-10	575	1	0.87	1075	2.3	5.4

Note:

1. Two speed.

# Jobsite Connections

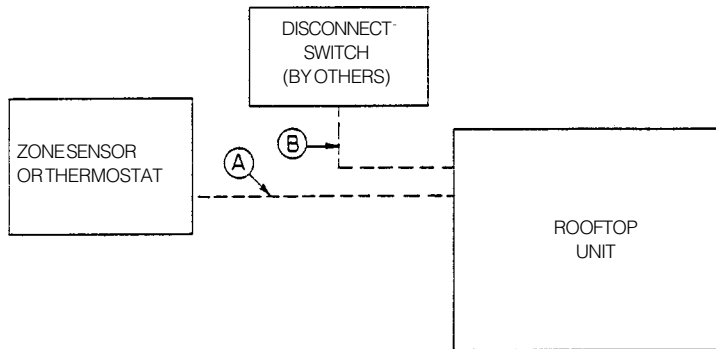

For specific wiring information, see the installation instructions.

All wiring except power wires is low voltage.

All customer supplied wiring to be copper and must conform to applicable electrical codes (such as NEC or CEC) and local electrical codes. Wiring shown dotted is to be furnished and installed by the customer.

## Zone Sensors — Typical Number Of Wires

A— Manual Changeover .....	4
Manual/Auto Changeover .....	5
Manual/Auto Changeover with Status Indication LED's .....	10
Programmable Night Setback with Status Indication LED's .....	7

## Thermostats — Typical Number of Wires

A — 3 wires, 24-volts, Cooling Only
4 wires, 24-volts, with Electric Heat
B — 3 Power Wires + 1 Ground Wire (three phase)
2 Power Wires + 1 Ground Wire (single phase)

# Dimensional Data

## (3-5 Tons)

All dimensions are in inches/millimeters.

### 3 - 5 Tons Standard Efficiency 3 and 4 Tons High Efficiency

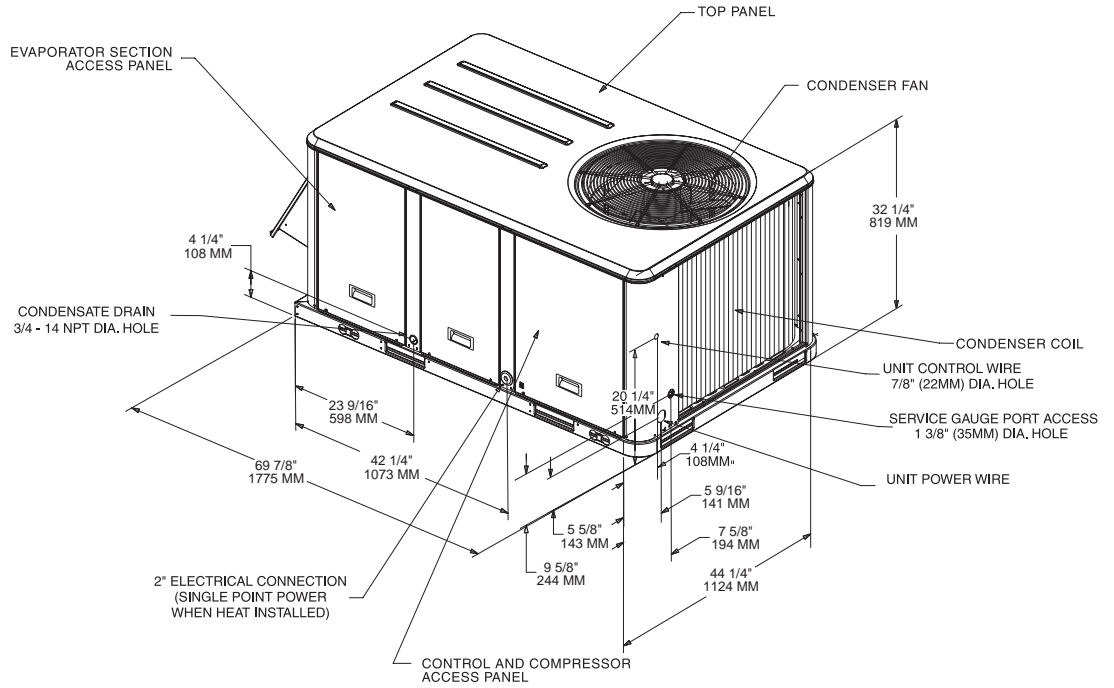

### 5 Tons High Efficiency

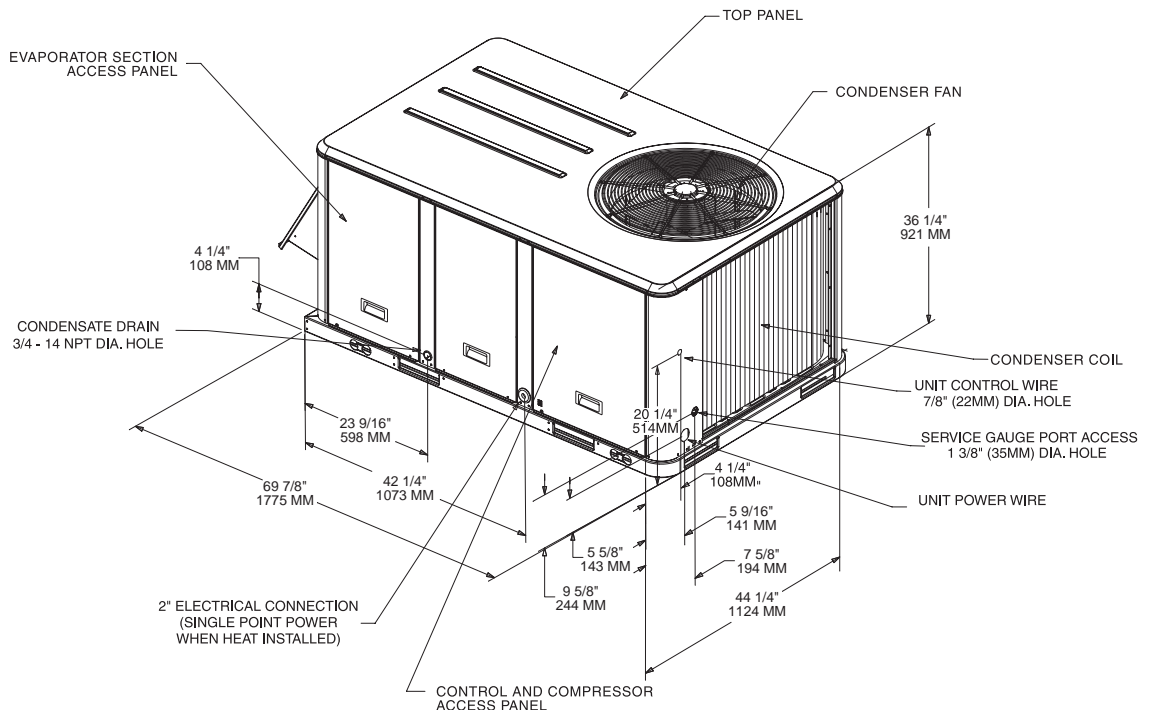

# Dimensional Data

## (3-5 Tons)

All dimensions are in inches/millimeters.

**Downflow Airflow Supply/Return Through the Base Utilities**

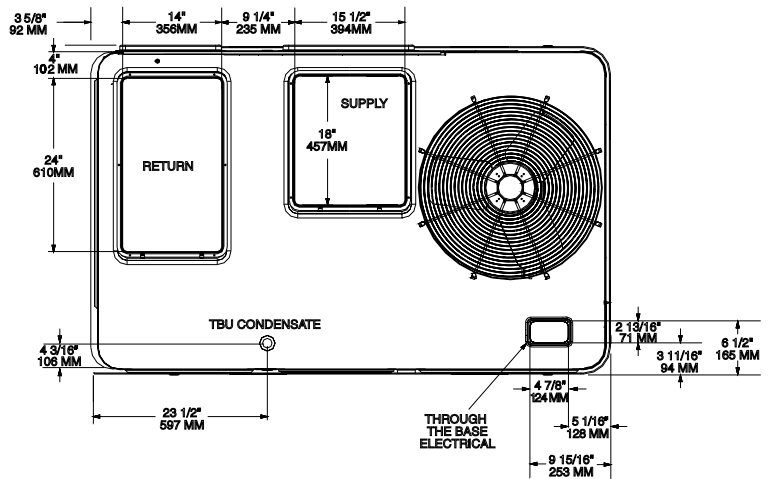

**Horizontal Airflow Supply/Return**

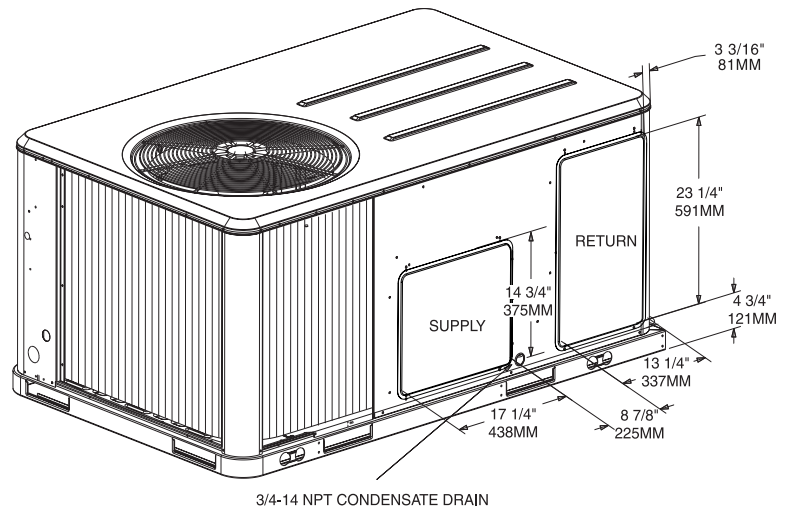

**Unit Clearance and Roof Opening**

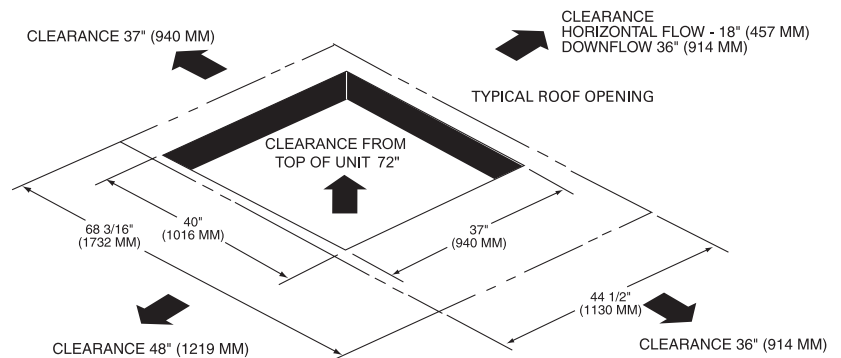

# Dimensional Data

## (3-5 Tons)

All dimensions are in inches.

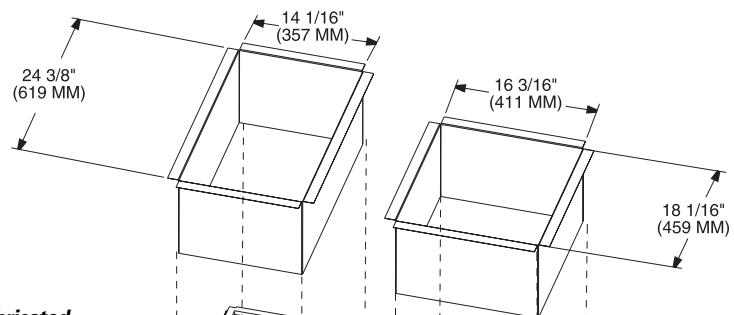
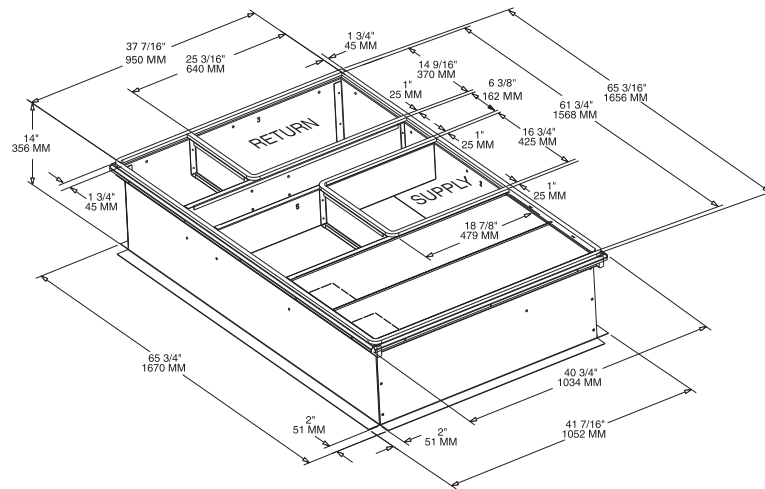

**Downflow Duct Connections – Field Fabricated**

ALL FLANGES 1 1/4" (32 MM)

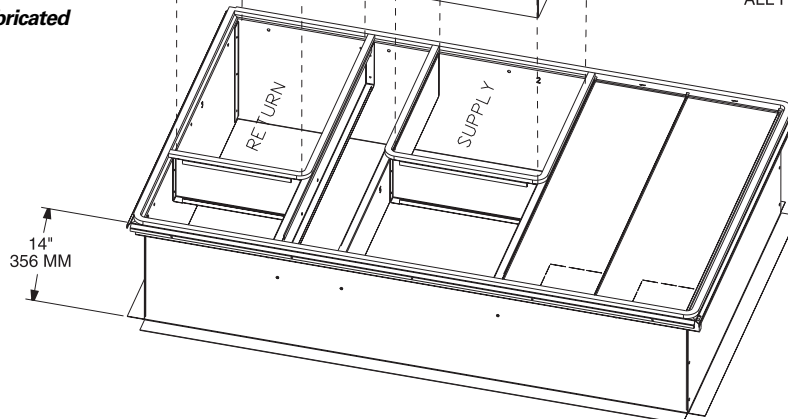



# Dimensional Data

## (6-10 Tons)

All dimensions are in inches.

**6 Tons Standard and High Efficiency  
7½ Tons Standard and High Efficiency**

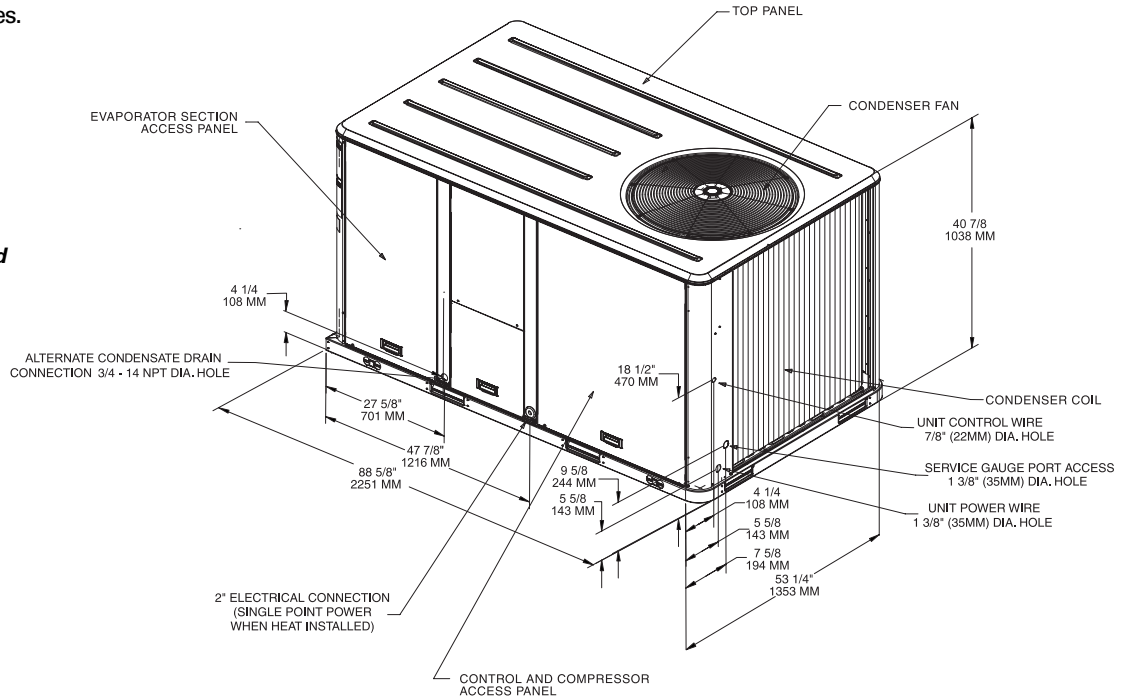

**7½ Tons High Efficiency  
8½ and 10 Tons Standard and High Efficiency**

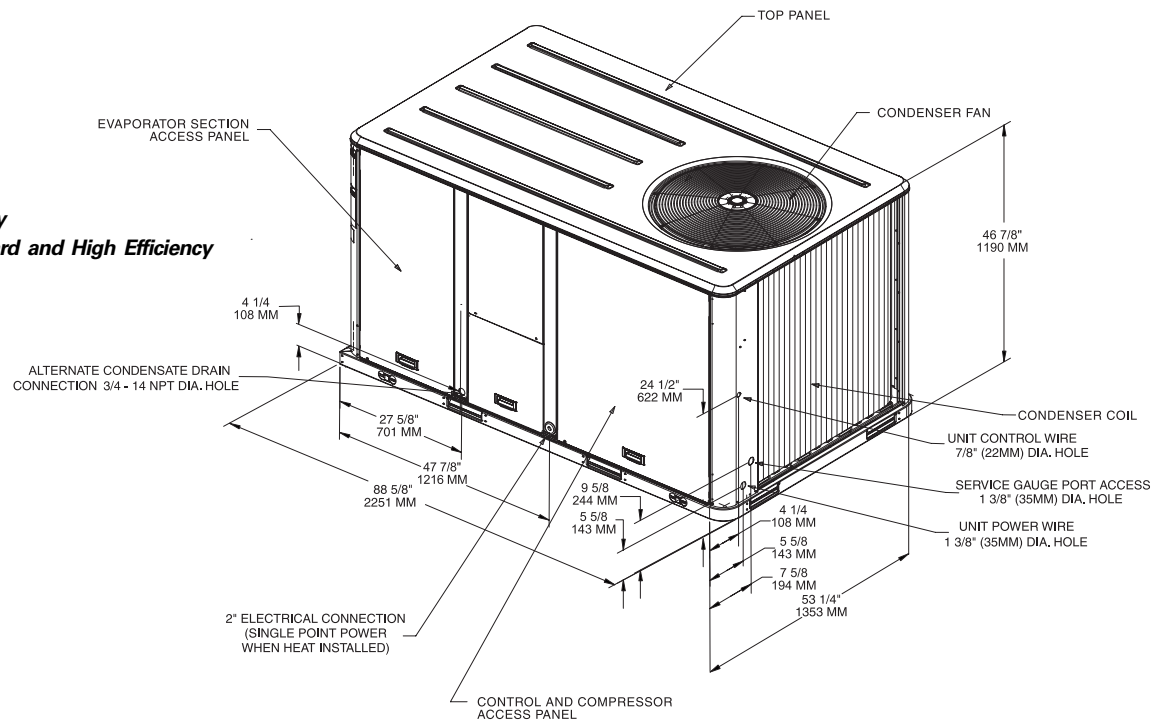

# Dimensional Data

## (6-10 Tons)

All dimensions are in inches.

### 6-10 Tons — Downflow Airflow Supply and Return; Through the Base Utilities

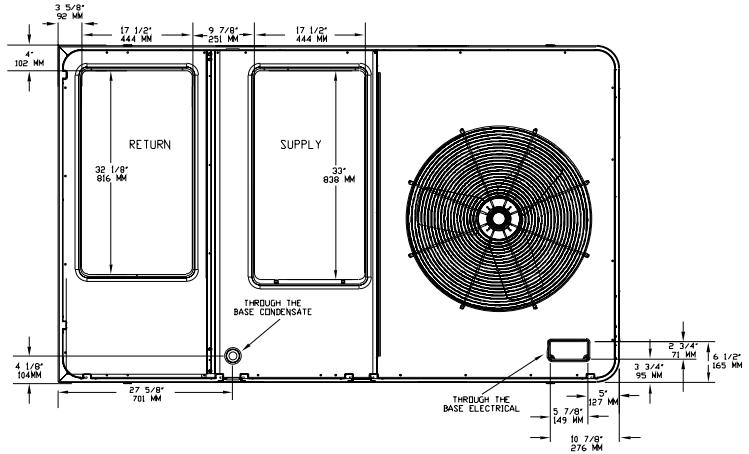

### 6-10 Tons — Horizontal Airflow Supply and Return

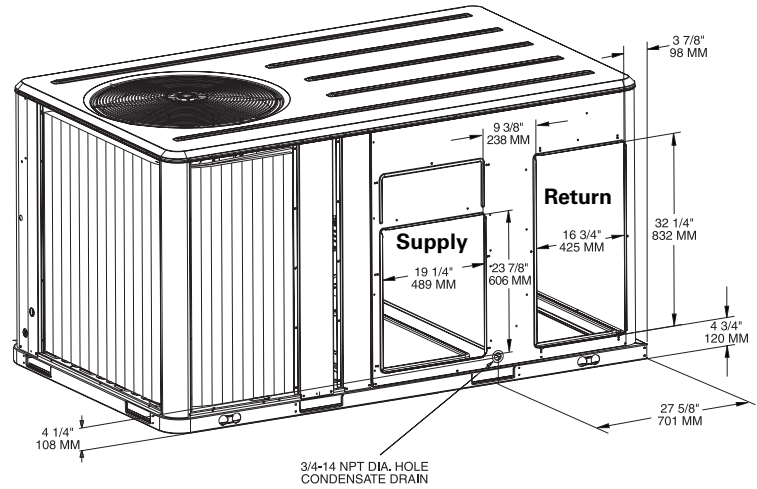

### 6-10 Tons — Unit Clearance and Roof Opening

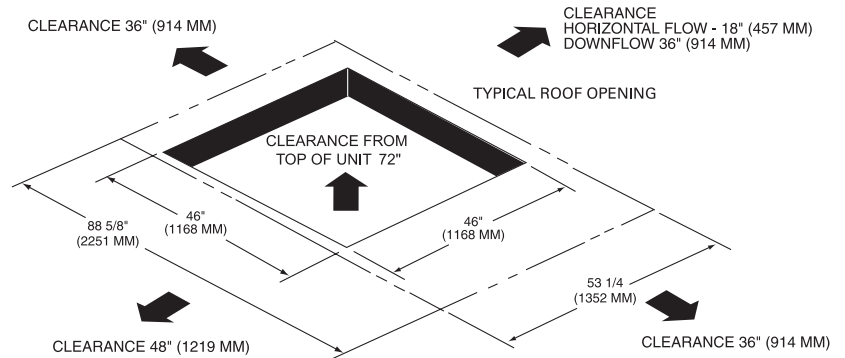



# Dimensional Data

(3-5 Tons Options/  
Accessories)

All dimensions are in inches.

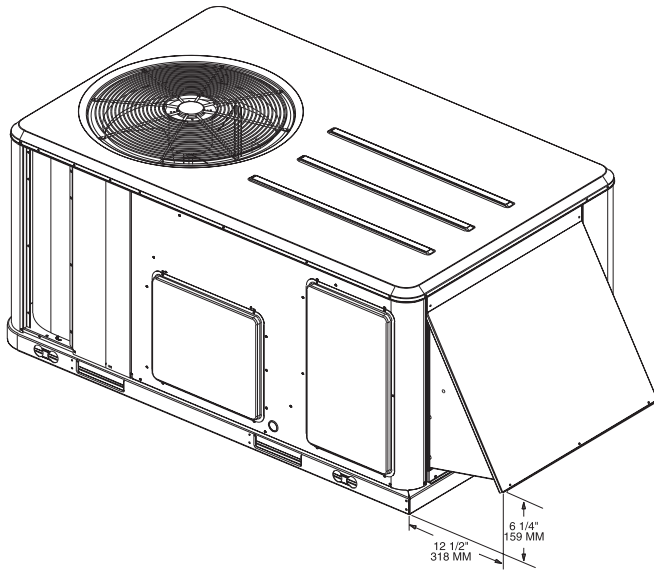

*Economizer , Manual or Motorized Fresh Air Damper*

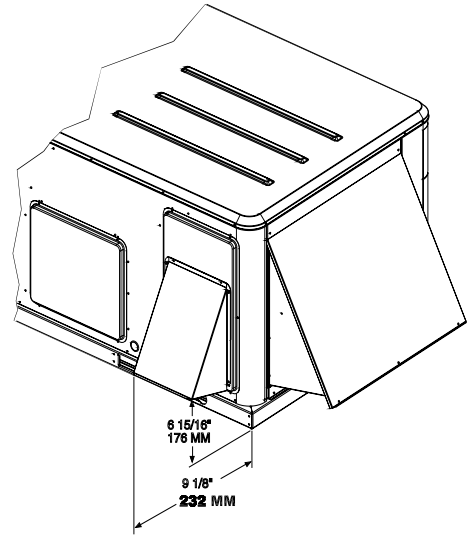

*Barometric Relief Damper Hood*

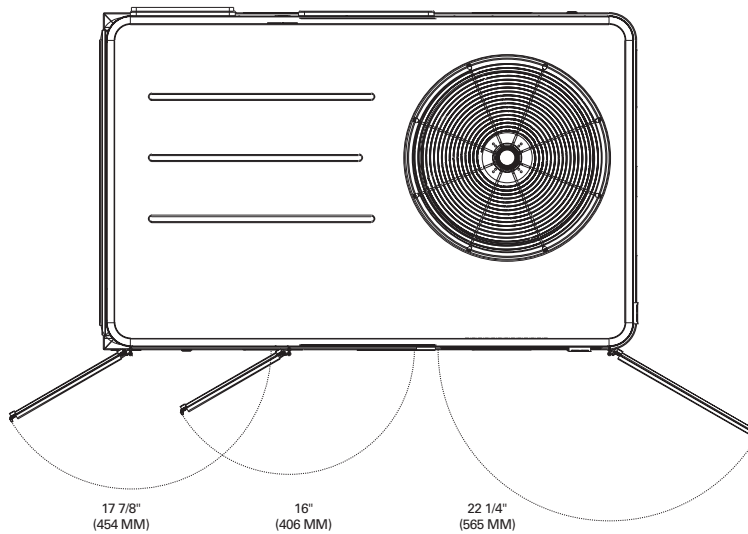

*Swing Diameter for Hinged Doors Option*

See Page 79 for Through the Base Utilities Information

# Dimensional Data

## (6-10 Tons Options/Accessories)

All dimensions are in inches.

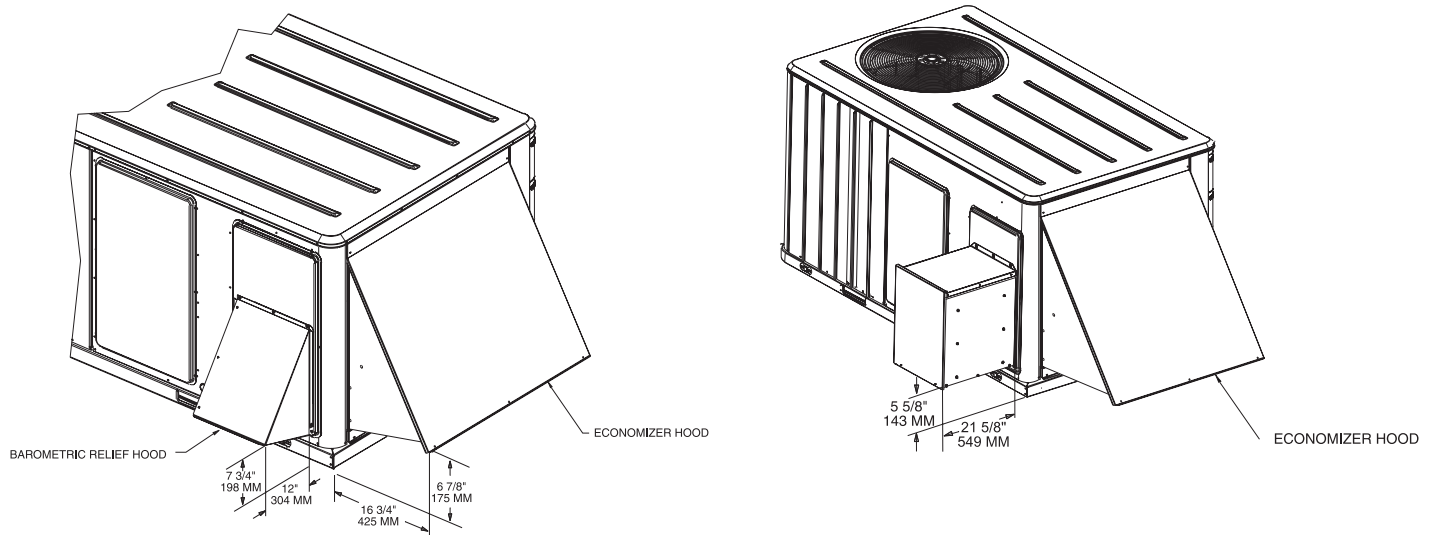

**6-10 Tons — Economizer and Barometric Relief Damper Hoods**

**6-10 Tons — Power Exhaust**

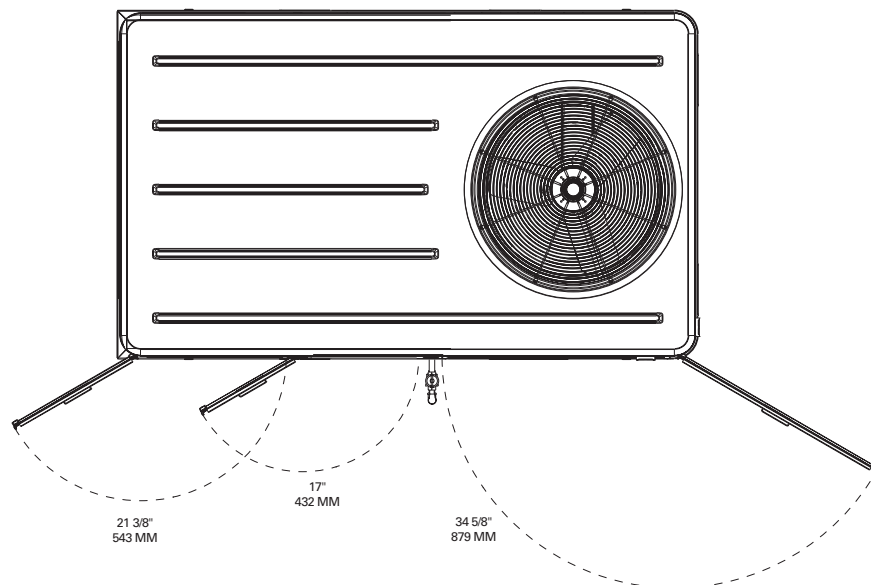

**6-10 Tons — Swing Diameter for Hinged Door(s) Option**

See Page 82 for Through the Base Utilities Information

# Weights

**Table W-1— Maximum Unit and Corner Weights (Lbs) And Center of Gravity Dimensions (In.)**

Tons	Unit Model No.	Maximum Weights (Lbs)		Corner Weights (Lbs) <sup>1</sup>				Center of Gravity (In.)	
		Shipping <sup>2</sup>	Net	A	B	C	D	Length	Width
3	TSC036A	501	409	132	104	79	94	31	19
	THC036A	518	426	139	108	84	95	32	19
4	TSC048A	526	434	140	110	91	94	33	19
	THC048A	560	468	146	113	97	111	31	20
5	TSC060A	543	451	149	114	88	99	31	18
	THC060A	610	518	165	124	105	124	31	19
6	TSC072A	824	681	236	177	119	150	38	21
	THC072A	861	718	235	182	128	173	38	22
7½	TSC090A	897	754	257	188	129	180	37	22
	TSC092A	899	756	261	202	131	162	39	21
	THC092A	1000	857	289	222	148	197	38	21
8½	TSC102A	978	835	281	223	149	181	40	21
	THC102A	1036	893	294	233	159	207	39	22
10	TSC120A	1023	880	298	238	158	187	40	21
	THC120A	1125	982	323	253	178	229	39	22

Notes:

1. Corner weights are given for information only.
2. Weights are approximate.

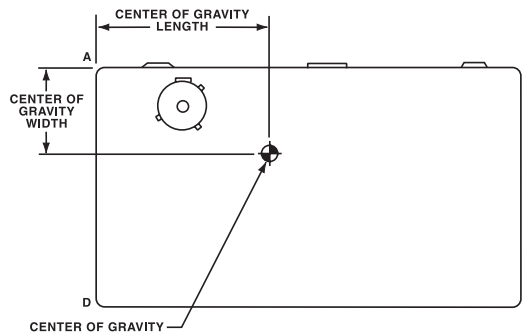

**Table W-2 — Factory-installed Options Net Weights (Lbs)<sup>1,2</sup>**

Accessory	Net Weight	
	3-5 Tons	6-10 Tons
Economizer	26	36
Barometric Relief	7	10
Powered Exhaust	—	80
Motorized Outside Air Damper	20	30
Manual Outside Air Damper	16	26
Roof Curb	70	115
Oversized Motor	5	8
Belt Drive Motor	31	—
Smoke Detector, Return	7	7
Smoke Detector, Supply	5	5
Coil Guards	12	20
Hinged Doors	10	12
Powered Convenience Outlet	38	38
Through the Base Electrical	8	13
Electric Heaters	15	30
Unit Mounted Circuit Breaker	5	5
Unit Mounted Disconnect	5	5
Novar Control	8	8
Dehumidification (Hot Gas Reheat) Coil	15	25

Notes:

1. Weights for options not listed are < 5 lbs.
2. Net weight should be added to unit weight when ordering factory-installed accessories.

# Mechanical Specifications

## General

The units shall be convertible airflow. The operating range shall be between 115°F and 0°F in cooling as standard from the factory for units with microprocessor controls. Operating range for units with electromechanical controls shall be between 115°F and 40°F. Cooling performance shall be rated in accordance with ARI testing procedures. All units shall be factory assembled, internally wired, fully charged with R-22, and 100 percent run tested to check cooling operation, fan and blower rotation, and control sequence before leaving the factory. Wiring internal to the unit shall be colored and numbered for simplified identification. Units shall be UL listed and labeled, classified in accordance to UL 1995/CAN/CSA No. 236-M90 for Central Cooling Air Conditioners. Canadian units shall be CSA Certified.

## Casing

Unit casing shall be constructed of zinc coated, heavy gauge, galvanized steel. Exterior surfaces shall be cleaned, phosphatized, and finished with a weather-resistant baked enamel finish. Unit's surface shall be tested 1000 hours in a salt spray test in compliance with ASTM B117. Cabinet construction shall allow for all maintenance on one side of the unit. Service panels shall have lifting handles and be removed and reinstalled by removing only a single fastener while providing a water and air tight seal. All exposed vertical panels and top covers in the indoor air section shall be insulated with a cleanable foil-faced, fire-retardent permanent, odorless glass fiber material. The base of the unit shall be insulated with 1/2 inch, 1 pound density foil-faced, closed-cell material. All insulation edges shall be either captured or sealed. The unit's base pan shall have no penetrations within the perimeter of the curb other than the raised 1<sup>1</sup>/<sub>8</sub> inch high downflow supply/return openings to provide an added water integrity precaution, if the condensate drain backs up. The base of the unit shall have provisions for forklift and crane lifting, with forklift capabilities on three sides of the unit.

## Unit Top

The top cover shall be one piece construction or where seams exist, it shall be double-hemmed and gasket-sealed. The ribbed top adds extra strength and prevents water from pooling on unit top.

## Filters

One inch, throwaway filters shall be standard on all 3-5 ton units. The filter rack can be converted to two inch capability. Two inch filters shall be factory supplied on all 6-10 ton units. Optional 2-inch pleated filters shall be available.

## Compressors

All 3 ton standard units shall have direct-drive, hermetic, reciprocating type compressors. The reciprocating type compressors have a centrifugal oil pump providing positive lubrication to moving parts. Motor shall be suction gas-cooled and shall have a voltage utilization range of plus or minus 10 percent of unit nameplate voltage. Crankcase heater, internal temperature, and current-sensitive motor overloads shall be included for maximum protection. Compressors shall have internal spring isolation and sound muffling to minimize vibration transmission and noise. Low pressure switches shall be standard.

3 ton high efficiency and 4-10 ton standard and high efficiency units shall have direct-drive, hermetic, scroll type compressors with centrifugal type oil pumps. Motor shall be suction gas-cooled and shall have a voltage utilization range of plus or minus 10 percent of unit nameplate voltage. Internal overloads shall be provided with the scroll compressors. Crankcase heaters shall be included on 7<sup>1</sup>/<sub>2</sub> ton standard efficiency units.

## Refrigerant Circuits

Each refrigerant circuit offers a choice of independent fixed orifice expansion devices or thermal expansion valve. Service pressure ports, and refrigerant line filter driers are factory-installed as standard. An area shall be provided for replacement suction line driers.

## Evaporator and Condenser Coils

Internally finned, 5/16" copper tubes mechanically bonded to a configured aluminum plate fin shall be standard. Coils shall be leak tested at the factory to ensure the pressure integrity. The evaporator coil and condenser coil shall be leak tested to 200 psig and pressure tested to 450 psig. The condenser coil shall have a patent pending 1+1+1 hybrid coil designed with slight gaps for ease of cleaning. A removeable, reversible, double-sloped condensate drain pan with provision for through the base condensate drain is standard.

## Outdoor Fans

The outdoor fan shall be direct-drive, statically and dynamically balanced, draw-through in the vertical discharge position. The fan motor shall be permanently lubricated and shall have built-in thermal overload protection.

## Indoor Fan

All 3-5 ton 3-phase units offer a choice of direct-drive, FC, centrifugal fans or belt driven, FC centrifugal fans with adjustable motor sheaves. 3-5 ton direct drive oversized motors shall be available for high static operations. All 6-10 ton units shall have belt drive motors with an adjustable idler-arm assembly for quick-adjustment to fan belts and motor sheaves. All motors shall be thermally protected. All indoor fan motors meet the U.S. Energy Policy Act of 1992 (EPACT).



# Mechanical Specifications

## Controls

Unit shall be completely factory-wired with necessary controls and contactor pressure lugs or terminal block for power wiring. Unit shall provide an external location for mounting a fused disconnect device.

A choice of microprocessor or electromechanical controls shall be available.

Microprocessor controls provide for all 24 volt control functions. The resident control algorithms shall make all heating, cooling, and/or ventilating decisions in response to electronic signals from sensors measuring indoor and outdoor temperatures. The control algorithm maintains accurate temperature control, minimizes drift from set point, and provides better building comfort. A centralized Microprocessor shall provide anti-short cycle timing and time delay between compressors to provide a higher level of machine protection.

24-volt electromechanical control circuit shall include control transformer and contactor pressure lugs for power wiring. Units shall have single point power entry as standard.

## Factory Installed Options

### Black Epoxy Pre-Coated Coils

The black epoxy coils have a thermoset vinyl coating that is bonded to the aluminum fin stock prior to the fin-stamping process. The pre-coated coils are an economical option for protection in mildly corrosive environments.

### Dehumidification Option

The dehumidification (hot gas reheat) option shall provide increased dehumidification. The option shall consist of a hot-gas reheat coil located on the leaving air side of the evaporator coil piped and circuited.

The option shall be equipped with crankcase heater(s), low pressure switch(es), Froststat™, and a thermostatic expansion valve(s) (TXV) as standard.

### High Pressure Cutout

This is offered for units that do not have High Pressure cutout as standard. All 3-phase units with scroll compressors include High Pressure Cutout as standard.

### Hinged Access Doors

Sheet metal hinges are available on the Filter/Evaporator, Supply Fan/Heat, and the Compressor/Control Access Doors.

### Novar Return Air Sensor

This option, when used in conjunction with Novar Controls, will contain a factory provided and wired zone temperature sensor located in the return air stream.

### Novar Unit Controls

Optional Novar rooftop unit controls shall be installed and tested. The Novar electronic thermostat module will interface to the unit microprocessor and will control the unit to the desired stage of cooling or heating.

### Phase Monitor

Phase monitor shall provide 100% protection for motors and compressors against problems caused by phase loss, phase imbalance, and phase reversal. Phase monitor is equipped with an LED that provides an ON or FAULT indicator.

## Powered or Unpowered Convenience Outlet

This is a GFCI, 120v/15amp, 2 plug, convenience outlet, either powered or unpowered. When the convenience outlet is powered, a service receptacle disconnect will be available. The convenience outlet is powered from the line side of the disconnect or circuit breaker, and therefore will not be affected by the position of the disconnect or circuit breaker. This option can only be ordered when the Through the Base Electrical with either the Disconnect Switch or Circuit Breaker option is ordered.

## Supply and/or Return Air Smoke Detector

With this option, if smoke is detected, all unit operation will be shut down. Reset will be manual at the unit. Return Air Smoke Detectors require minimum allowable airflow when used with certain models. See the Installation, Operation, and Maintenance (IOM) manual for the models affected and the minimum allowable airflow required. This option is available for microprocessor controlled units.

## Thermal Expansion Valve

All units shall have a short orifice refrigerate control metering device. For more exact refrigerant flow, when using unit in low airflow applications, a Thermal Expansion Valve option shall be available.

## Through the Base Electrical Access

An electrical service entrance shall be provided allowing electrical access for both control and main power connections inside the curb and through the base of the unit. Option will allow for field installation of liquid-tight conduit and an external field-installed disconnect switch.



# Mechanical Specifications

## Through the Base Electrical with Circuit Breaker

This option is a thermal magnetic, molded case, HACR Circuit Breaker with provisions for through the base electrical connections. The circuit breaker will be installed in a water tight enclosure in the unit with access through a swinging door. Wiring will be provided from the switch to the unit high voltage terminal block. The circuit breaker will provide overcurrent protection, be sized per NEC and UL guidelines, and be agency recognized by UL/CSA.

## Through the Base Electrical with Disconnect Switch

This 3-pole, molded case, disconnect switch with provisions for through the base electrical connections are available. The disconnect switch will be installed in the unit in a water tight enclosure with access through a swinging door. Wiring will be provided from the switch to the unit high voltage terminal block. The switch will be UL/CSA agency recognized. **Note:** The disconnect switch will be sized per NEC and UL guidelines but will not be used in place of unit overcurrent protection.

## Two-Inch Pleated Filters

Two inch pleated media filters shall be available on all models.

## Factory or Field Installed Options

### Clogged Filter/Fan Failure Switch

A dedicated differential pressure switch is available to achieve active fan failure indication and/or clogged filter indication. These indications will be registered with either a zone sensor with status indication lights or an Integrated Comfort™ System. This option is available for microprocessor controlled units.

### Differential Pressure Switches

These sensors allow individual fan failure and dirty filter indication for microprocessor controlled units. The fan failure switch will disable all unit functions and "flash" the Service LED on the zone sensor. The dirty filter switch will light the Service LED on the zone sensor and will allow continued unit operation.

## Discharge Air Sensing

This option provides true discharge air sensing in heating models. This sensor is a status indicator readable through Tracer™ or Tracker™. This option is available for microprocessor controlled units.

## Economizer

This accessory shall be available with or without barometric relief. The assembly includes fully modulating 0-100 percent motor and dampers, minimum position setting, preset linkage, wiring harness with plug, spring return actuator and fixed dry bulb control. The barometric relief shall provide a pressure operated damper that shall be gravity closing and shall prohibit entrance of outside air during the equipment "off" cycle. Optional solid state or differential enthalpy control shall be available for either factory or field installation. The economizer arrives in the shipping position and shall be moved to the operating position by the installing contractor.

## Electric Heaters

Electric heat modules shall be available for installation within basic unit. Electric heater elements shall be constructed of heavy-duty nickel chromium elements internally delta connected for 240 volt, wye connected for 480 and 600 volt. Staging shall be achieved through ReliaTel™. Each heater package shall have automatically reset high limit control operating through heating element contactors. All heaters shall be individually fused from the factory, where required, and shall meet all NEC and CEC requirements when properly installed. Power assemblies shall provide single-point connection. Electric heat modules shall be UL listed or CSA certified.

## Frostat

This option is to be utilized as a safety device. The Frostat opens when temperatures on the evaporator coil fall below 10°F. The temperature will need to rise to 50°F before closing. This option should be utilized in low airflow or high outside air applications.

## LonTalk® Communication Interface

This option shall be provided to allow the unit to communicate as a Tracer™ LCI-R device or directly with generic LonTalk Network Building Automation System Controls.

## Oversized Motors

Direct drive oversized motors shall be available for high static applications.

## Reference or Comparative Enthalpy

Reference Enthalpy is used to measure and communicate outdoor humidity. The unit receives and uses this information to provide improved comfort cooling while using the economizer. Comparative Enthalpy measures and communicates humidity for both outdoor and return air conditions, and return air temperature. The unit receives and uses this information to maximize use of economizer cooling, and to provide maximum occupant comfort control. Reference or Comparative Enthalpy option shall be available when a factory or field installed Downflow Economizer is ordered. This option is available on all downflow models.

## Tool-less Hail Guards

Tool-less, hail protection quality coil guards are available for condenser coil protection.

## Trane Communication Interface

This option shall be provided to interface ReliaTel™ controlled units with the Trane Integrated Comfort™ systems.

# Mechanical Specifications

---

## Field Installed Options

### CO<sub>2</sub> Sensing

The CO<sub>2</sub> sensor shall have the ability to monitor space occupancy levels within the building by measuring the parts per million of CO<sub>2</sub> (Carbon Dioxide) in the air. As the CO<sub>2</sub> levels increase, the outside air damper modulates to meet the CO<sub>2</sub> space ventilation requirements.

### Digital Display Zone Sensor

The Digital LCD (Liquid Crystal Display) zone sensor has the look and functionality of standard zone sensors. This sensor includes a digital display of set point adjustment and space temperature in F (Fahrenheit) or C (Celsius). Includes FAN and SYSTEM buttons (supports the service functions of the standard sensor). E-squared memory stores last programmed set points. Requires 24 VAC (Volts AC). This sensor should be utilized with ReliaTel™ controls.

### Dual Thermistor Remote Zone Sensor

This sensor will allow the customer to reduce the total number of remote sensors to obtain space temperature averaging. This sensor should be utilized with ReliaTel controls.

### High Static Drive

The high static drive option shall allow the standard motor on the 6 and 7½ ton units to operate with improved external static capabilities.

### Humidity Sensor

This wall-mounted humidity sensor is used to control activation of the hot gas reheat dehumidification option. The humidity sensor can be set for humidity levels between 40% and 60% relative humidity by adjusting the ReliaTel Options Module.

### Humidity Sensor

This duct-mounted humidity sensor is used to control activation of the hot gas reheat dehumidification option. The humidity sensor can be set for humidity levels between 40% and 60% relative humidity by adjusting the ReliaTel Options Module.

### Manual Outside Air Damper

This rain hood and screen shall provide up to 50 percent outside air.

### Motorized Outside Air Dampers

Manually set outdoor air dampers shall provide up to 50 percent outside air. Once set, outdoor air dampers shall open to set position when indoor fan starts. The damper shall close to the full closed position when indoor fan shuts down.

### Powered Exhaust

The powered exhaust, available for 6-10 ton units, shall provide exhaust of return air, when using an economizer, to maintain better building pressurization.

### Remote Potentiometer

The minimum position setting of the economizer shall be adjusted with this accessory.

### Roof Curb

The roof curb shall be designed to mate with the unit's downflow supply and return and provide support and a water tight installation when installed properly. The roof curb design shall allow field-fabricated rectangular supply/return ductwork to be connected directly to the curb. Curb design shall comply with NRCA requirements. Curb shall be shipped knocked down for field assembly and shall include wood nailer strips.

### Thermostat

Two stage heating and cooling operation or one stage heating and cooling shall be available in either manual or automatic changeover. Automatic programmable electronic with night set back shall also be available.

### Ventilation Override Accessory

With the Ventilation Override Accessory installed, the unit can be set to transition up to 3 different pre-programmed sequences for Smoke Purge, Pressurization, and Exhaust. The transition occurs when a binary input on the RTOM is closed (shorted). This would typically be a hard wired relay output from a smoke detector or fire control panel. The ventilation override accessory shall be available as field installed.

### Zone Sensor

This control shall be provided to interface with the Micro equipped units and shall be available in either manual, automatic programmable with night setback, with system malfunction lights, or remote sensor options.





\*High Efficiency Units only



**Trane**  
**A business of American Standard Companies**  
**www.trane.com**

For more information contact your local dealer  
(distributor), local district office, or e-mail us at  
comfort@trane.com

---

Literature Order Number	RTPRC005-EN
File Number	PL-UN-RT-TSC/THC 3-10TONS-PRC005-EN-08-04
Supersedes	PL-UN-RT-TSC/THC 3-10TONS-PRC005-EN-05-04
Stocking Location	05-04 Webb/Mason 08-04 Electronic Only

---

*Trane has a policy of continuous product and product data improvement and reserves the right to change design and specifications without notice.*

## Free Manuals Download Website

<http://myh66.com>

<http://usermanuals.us>

<http://www.somanuals.com>

<http://www.4manuals.cc>

<http://www.manual-lib.com>

<http://www.404manual.com>

<http://www.luxmanual.com>

<http://aubethermostatmanual.com>

Golf course search by state

<http://golfingnear.com>

Email search by domain

<http://emailbydomain.com>

Auto manuals search

<http://auto.somanuals.com>

TV manuals search

<http://tv.somanuals.com>