



Installation, Operation, and Maintenance

Integral Air-Cooled Self-Contained Unit



Model SCIH

"AO" and later design sequence

September 2007

SXIH-SVX01B-EN

About This Manual Literature Change History

Use this manual for Integral Air-Cooled units, model SCIH. This is the second issue of this manual, which includes the addition of the accessory model number and instructions on how to convert the unit to a horizontal discharge with correct belt sizes. Also, it provides specific installation, operation, and maintenance instructions for "AO" and later design sequences.

Note: *The procedures discussed in this manual should only be performed by qualified, experienced HVAC technicians.*

Note: *This document is customer property and must be retained by the unit's owner for use by maintenance personnel.*

Overview of Manual

This booklet describes proper installation, start-up, operation, and maintenance procedures for the Integral Air-Cooled unit, model SCIH. Carefully review the information within this manual and follow the instructions to minimize the risk of improper operation and/or component damage.

Note: *One copy of this manual ships inside the control panel of each unit.*

It is important that you perform periodic maintenance to help ensure trouble free operation. Should equipment failure occur, contact a qualified Trane service organization for an experienced HVAC technician to properly diagnose and repair this equipment.

Note: *Do not release refrigerant to the atmosphere!*

If adding or removing refrigerant is required, the service technician must comply with all federal, state, and local laws.

Warnings and Cautions

Warnings and cautions appear at appropriate sections throughout this manual. Read these carefully.

WARNING

Indicates a potentially hazardous situation, which could result in death or serious injury if not avoided.

CAUTION

Indicates a potentially hazardous situation which, if not avoided, may result in minor or moderate injury. It may also be used to alert against unsafe practices.

CAUTION

Indicates a situation that may result in equipment or property-damage-only accidents.

Sample Warnings and Cautions

WARNING

Hazardous voltage!

Disconnect all electric power, including remote disconnects before servicing. Follow proper lockout/tagout procedures to ensure the power can not be inadvertently energized. Failure to disconnect power before servicing could result in death or serious injury.

CAUTION

Use copper conductors only!

Unit terminals are not designed to accept other types of conductors. Failure to use copper conductors may result in equipment damage.

Common HVAC Acronyms

For convenience, a number of acronyms and abbreviations are used throughout this manual. These acronyms are alphabetically listed and defined below.

cfm = cubic-feet-per-minute
CKT. = circuit
CV = constant volume
CW = clockwise
CCW = counterclockwise
E/A = exhaust air
F/A = fresh air
IOM= installation/operation/maintenance manual
LH = left-hand
O/A = outside air
psig = pounds-per-square-inch, gauge pressure
R/A = return air
RH = right-hand
RPM = revolutions-per-minute
S/A = supply air
SZ = single-zone (unit airflow)
VAV = variable air volume

Special Note on Refrigeration Emissions

World environmental scientists have concluded that ozone in our upper atmosphere is being reduced due to the release of CFC fully halogenated compounds. Trane urges all HVAC service personnel to make every effort to prevent any refrigerant emissions while installing, operating, or servicing equipment. Always conserve refrigerant for continued use and follow all warnings and cautions in this manual.

contents

Cross reference to related publications:

- *Integral Air-Cooled Self-Contained Product Catalog, PKG-PRC009-EN*

Installation	2
general information	2
pre-installation considerations	7
dimensions and weights	8
mechanical requirements	12
electrical requirements	13
installation procedure	15
pre-startup requirements	19
startup	20
Operation	21
sequence of operation	21
Maintenance	22
general information	22
maintenance procedures	23
periodic checklists	26



Installation

general information

Integral Air-Cooled Model Number Description

Following is a complete description of the integral air-cooled unit model number. Each digit in the model number has a corresponding code that identifies specific unit options.

S C I H 075 3 1 A0 1 0 1 0 0
1 2 3 4 567 8 9 10 11 12 13 14 15 16

Digit 1 - Unit Model

S = self contained

Digit 2 - Unit Type

C = commercial

Digit 3 - Condenser Medium

I = integral air-cooled

Digit 4 - Development Sequence

H = development series

Digit 5, 6, 7- Unit Nominal Capacity

050 = 5 tons

075 = 7.5 tons

100 = 10 tons

150 = 15 tons

Digit 8 - Unit Voltage

3 = 208 - 230 volt/60 hz/3 ph

4 = 460 volt/60 hz/3 ph

5 = 575 volt/60 hz/3 ph

Digit 9 - Air Flow Configuration

1 = horizontal discharge / rear return

2 = vertical discharge / front return

3 = vertical discharge / rear return

Digit 10, 11 - Design Sequence

A0 = design sequence

Digit 12 - Air Filter Type

1 = one-inch fiberglass throwaway

Digit 13 - Control

0 = control interface

Digit 14 - Unit Finish

1 = painted

2 = coated finish only

Digit 15 - Coil Finish

0 = none

C = condenser coated

E = evaporator coated

H = condenser + evaporator coated

Digit 16 - Agency Listing

A = C ETL listing

Installation

Accessory Model Number Description

Following is a complete description of the integral air-cooled accessory model number. Each digit in the model number has a corresponding code that identifies specific unit options.

P V I H A A 1 1 1 A0 A 0 1 1
1 2 3 4 5 6 7 8 9 10 11 12 13 14

Digit 1 - Parts/Accessories

P = parts/accessories

Digit 2 - Unit Model

V = vertical self contained

Digit 3 - Condenser Medium

I = integral air-cooled

Digit 4 - Development Sequence

H = development sequence

Digit 5 - Thermostat

0 = none

A = 10/15 ton t-stat 2C w/auto base

D = 10/15 ton prg. t-stat 2H2C w/2H2C base

E = 10/14 ton t-stat 2H2C w/auto base

F = 10/15 ton t-stat 2H2C w/auto/mnl base

G = 10/15 ton t-stat 2H2C w/mnl base

H = 5/7.5 ton prg t-stat 2H2C w/mnl base

J = 5/7.5 ton t-stat 1H1C base

K = 5/7.5 ton t-stat 1H1C w/auto/mnl base

L = 5/7.5 ton t-stat 1H1C w/mnl base

Digit 6 - Remote Wall Sensor

0 = none

A = remote wall sensor

Digit 7 - Heat Coil

0 = none

1 = 5-ton hot water coil

2 = 7.5-ton hot water coil

3 = 10/15-ton hot water coil

4 = 5-ton steam coil

5 = 7.5-ton steam coil

6 = 10/15-ton steam coil

Digit 8 - Discharge Plenum

0 = none

1 = 5-ton plenum

2 = 7.5-ton plenum

3 = 10-ton plenum

4 = 15-ton plenum

Digit 9 - Low Ambient Damper

0 = none

1 = 5/7.5-ton low ambient damper

2 = 10/15-ton low ambient damper

Digit 10 - Design Sequence

** = factory assigned

Digit 11 - Oversize Motor Condenser

0 = none

A = 5-ton, 208V condenser, OS motor kit

B = 7.5-ton, 208V condenser, OS motor

C = 10-ton, 208V condenser, OS motor

D = 15-ton, 208V condenser, OS motor

E = 5-ton, 460V condenser, OS motor

F = 7.5-ton, 460V condenser, OS motor

G = 10-ton, 460V condenser, OS motor

H = 15-ton, 460V condenser, OS motor

J = 5-ton, 575V condenser, OS motor

K = 7.5-ton, 575V condenser, OS motor

L = 10-ton, 575V condenser, OS motor

M = 15-ton, 575V condenser, OS motor

Digit 12 - Oversize Motor Evaporator

0 = none

A = 5-ton, 208V evaporator, OS motor

B = 7.5-ton, 208V evaporator, OS motor

C = 10-ton, 208V evaporator, OS motor

D = 15-ton, 208V evaporator, OS motor

E = 5-ton, 460V evaporator, OS motor

F = 7.5-ton, 460V evaporator, OS motor

G = 10-ton, 460V evaporator, OS motor

H = 15-ton, 460V evaporator, OS motor

J = 5-ton, 575V evaporator, OS motor

K = 7.5-ton, 575V evaporator, OS motor

L = 10-ton, 575V evaporator, OS motor

M = 15-ton, 575V evaporator, OS motor

Digit 13 - Filter

0 = none

1 = 5-ton 1" fiberglass TA, 6PC

2 = 5-ton 2" fiberglass TA, 6PC

3 = 5-ton 2" mesh filter washable, 6PC

4 = 7.5-ton 1" fiberglass TA, 6PC

5 = 7.5-ton 2" fiberglass TA, 6PC

6 = 7.5-ton 2" mesh filter washable, 6PC

7 = 10/15-ton 1" fiberglass TA, 6PC

8 = 10/15-ton 2" fiberglass TA, 6PC

9 = 10/15-ton 2" mesh filter washable, 6PC

Digit 14 - Filter Rack Kit

0 = none

A = 5-ton filter rack kit

B = 7.5-ton filter rack kit

C = 10-ton filter rack kit

D = 15-ton filter rack kit

Installation

general information

General Information

The integral air-cooled unit, model SCIH, is a high efficiency, vertical air cooled air conditioner. Units have either front or top discharge configuration options and easy service access. Unit construction is heavy gage steel with a baked enamel finish. Available unit voltages are 208/3/60, 230/3/60, and 460/3/60, 575/3/60.

Refrigeration Circuits

Units are configured in single or double refrigeration circuits. Each circuit consists of a:

- high efficiency scroll compressor mounted on rubber isolation grommets
- condenser and evaporator coils, designed for optimum performance and efficiency with lanced fins and rifled tubing,
- and filter-drier.

Evaporator Section

The evaporator fan section consists of one or two forward curved centrifugal fans powered by a premium efficiency motor through an adjustable motor sheave, and fixed diameter blower pulley. The condenser fan section consists of one or two forward curved centrifugal fans powered by a premium efficiency motor through an adjustable motor sheave and fixed diameter blower pulley. Condenser motor belt tension is adjusted by an adjustable motor mounting base.

Control box access is from the front of the unit to ease electrical hook-up.

Controls

The standard control panel consists of a high voltage terminal block, overload relays for each fan motor, transformer, 3-pole 24 volt contactors for each motor and compressor, and a 5-second delay timer. Remote thermostat controls are field-installed.

Field Installed Accessories

These items ship separately for field installation:

- steam coil
- hot water coil
- plenum
- low ambient damper
- oversized motors
- remote thermostat

Note: Application of the above options and/or accessories may require field adjustment of fan speeds to ensure proper airflow and performance.

Unit Nameplate

The unit nameplate identifies the unit model number, appropriate service literature, and wiring diagram numbers. It is mounted on the control panel door. Reference this information when making inquires or ordering parts or literature.

pre-installation considerations

Installation

Pre-Installation Considerations

Checklist

The following checklist gives an overview of the recommended pre-installation considerations. Follow the procedures in this section to ensure installation is complete and adequate for proper unit operation. Verify this checklist is complete before beginning unit installation.

- Verify the unit size and tagging with the unit nameplate to ensure the correct unit is received.
- Inspect the unit for possible shipping damage and make any necessary claims with the freight delivery company immediately.
- Before installing the unit, remember to allow minimum recommended clearances for routine maintenance and service. Refer to unit dimensions and clearances on submittals or in the Dimensions and Weights section.
- Verify the unit is configured properly prior to beginning unit installation.
- Make proper acoustic considerations before installing unit. Do not install unit near sound-sensitive locations.
- Allow adequate space for service and operating clearances. Reference "Service Access" section on this page.
- Make provisions for correct supply power and note electrical connection knockouts locations on the unit submittals or in the Dimensions and Weights section.
- Ensure the unit installation location is level.

Receiving and Handling

Shipping Package

Integral air-cooled units ship assembled on skids. Units ship in the unitary configuration, assembled, piped, and charged with refrigerant.

Receiving Checklist

Complete the following checklist immediately after receiving unit shipment to detect possible shipping damage.

- Verify that the unit nameplate data corresponds to the sales order and bill of lading (including electrical data).
- Visually inspect the unit exterior for physical signs of shipping damage or material shortages.
- If a unit appears damaged, inspect it

immediately before accepting the shipment. Remove access panels and check for interior component damage. Make specific notations concerning the damage on the freight bill. Do not refuse delivery.

- Report concealed damage to the freight line within the allotted time after delivery. Verify with the carrier their allotted time to submit a claim.

Note: Failure to follow these procedures may result in no reimbursement for damages from the freight company.

- Do not move damaged material from the receiving location. It is the receiver's responsibility to provide reasonable evidence that concealed damage did not occur after delivery.
- Do not continue unpacking the shipment if it appears damaged. Retain all packaging. Take photos of damaged material if possible.
- Notify the carrier's terminal of the damage immediately by phone and mail. Request an immediate joint inspection of the damage by the carrier and consignee.
- Notify your Trane representative of the damage and arrange for repair. Have the carrier inspect the damage before making any repairs to the unit.

Unit Storage

Take precautions to prevent condensate from forming inside the unit's electrical compartments and motors if the unit is stored before it is installed.

Service Access

Maintain adequate clearances around and above the unit to ensure proper unit operation and allow sufficient service access. Trane recommends 36-inches service access on all sides of the unit.

WARNING

Hazardous voltage!

Disconnect all electric power, including remote disconnects before servicing. Follow proper lockout/tagout procedures to ensure the power can not be inadvertently energized. Failure to disconnect power before servicing could result in death or serious injury.

Acoustic Considerations

Before determining the final unit installation site, remember that proper unit placement is critical in reducing transmitting sound levels to the building. The ideal time to make provisions to reduce sound transmissions is during the design phase. The most economical means of avoiding a potential acoustical problem is to place units in areas that are not acoustically sensitive.

Unit Location

Install the unit in a dry, indoor area between 50 and 115°F. Choose a location where sound levels, airflow and vibration, commonly associated with heavy-duty commercial equipment, will not be objectionable to occupants. In multiple unit installations, separate the individual units and stagger their location from floor to floor so as not to starve units for air and not to discharge warm condenser air from one condenser into the intake of another condenser. Place thermostats, air supplies and returns so that the individual unit will operate within its zone.

Installation Preparation

Before installing the unit, perform the following procedures to ensure proper unit operation.

1. Verify the installation location is level. To ensure proper unit operation, install the unit level (zero tolerance) in both horizontal axes. Failure to level the unit properly can result in condensate management problems, such as standing water inside the unit. Standing water and wet surfaces inside units can result in microbial growth (mold) in the drain pan that may cause unpleasant odors and serious health-related indoor air quality problem.
2. Allow adequate service and code clearances as recommended in the Service Access section.
3. Position the unit in its final location.

Unit Placement

Install the unit on a firm, level surface.

Installing Optional Accessories

Before installing ductwork, install accessories on unit.

Installation

dimensions and weights

Model SCIH 5 & 7.5-ton units

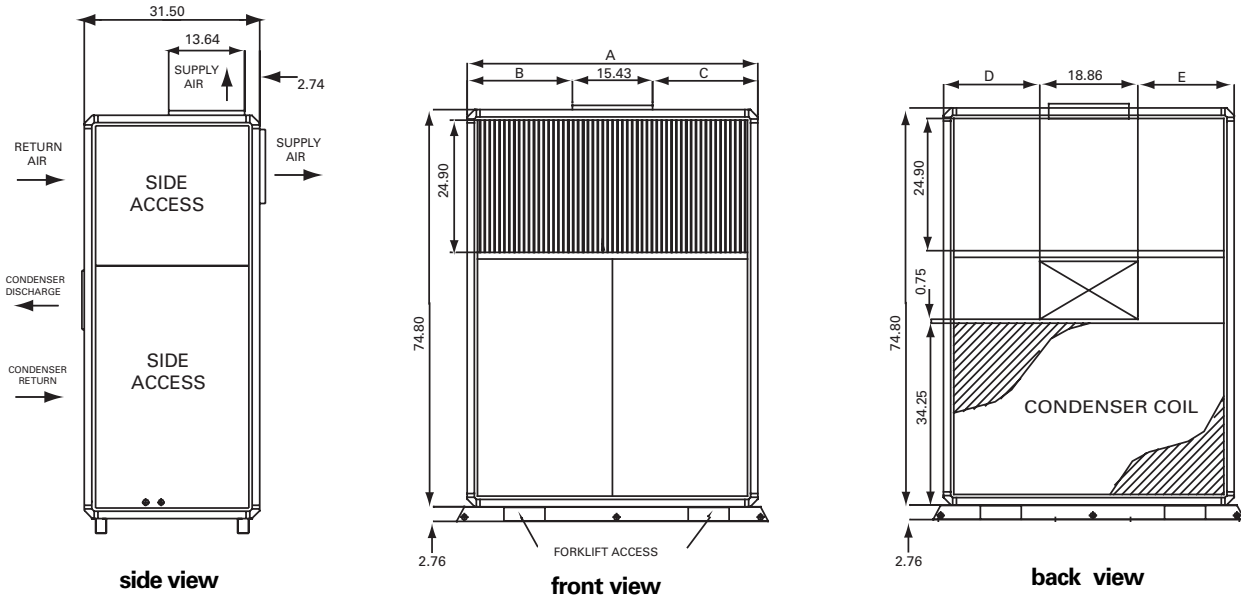

SCIH Unit Dimensions & Weights, in-lbs.

Unit Size	A	B	C	D	E	Ship. Wgt.	Oper. Wgt.
5 ton	42.72	9.29	17.99	8.15	15.70	864	798
7.5 ton	56.69	20.63	20.63	18.92	18.92	960	881
10 ton	—	—	—	—	—	1333	1241
15 ton	—	—	—	—	—	1480	1388

Model SCIH 10 & 15-ton units

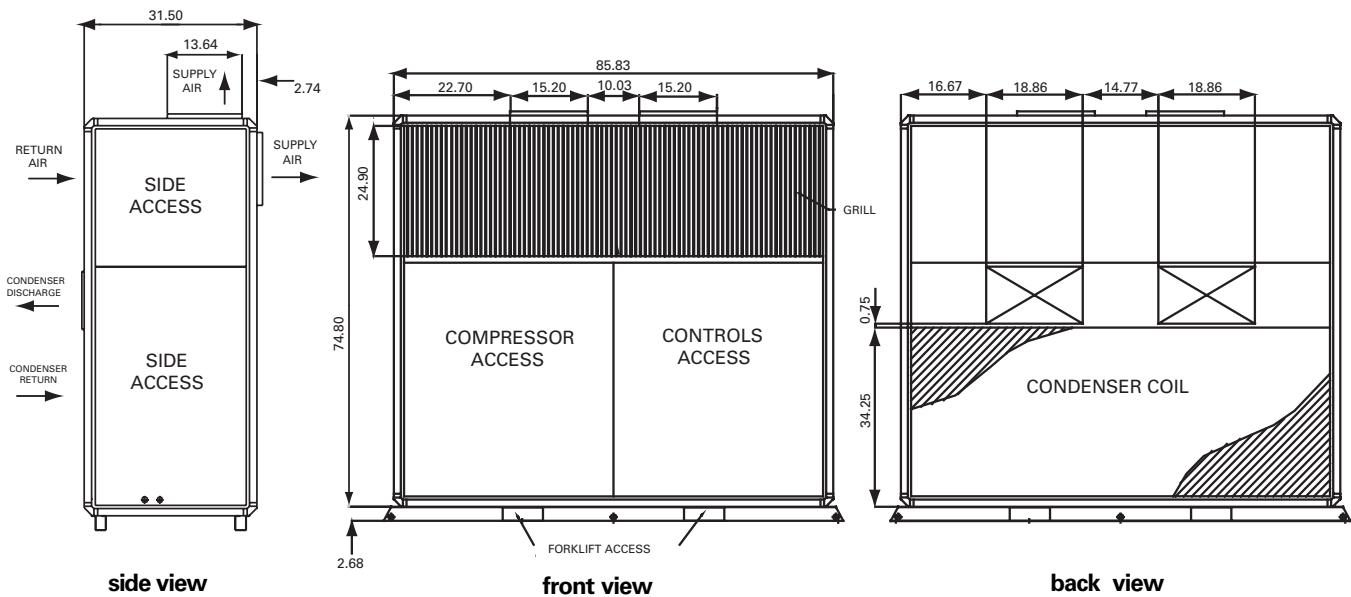

Installation

dimensions and weights

SCIH Component Overview

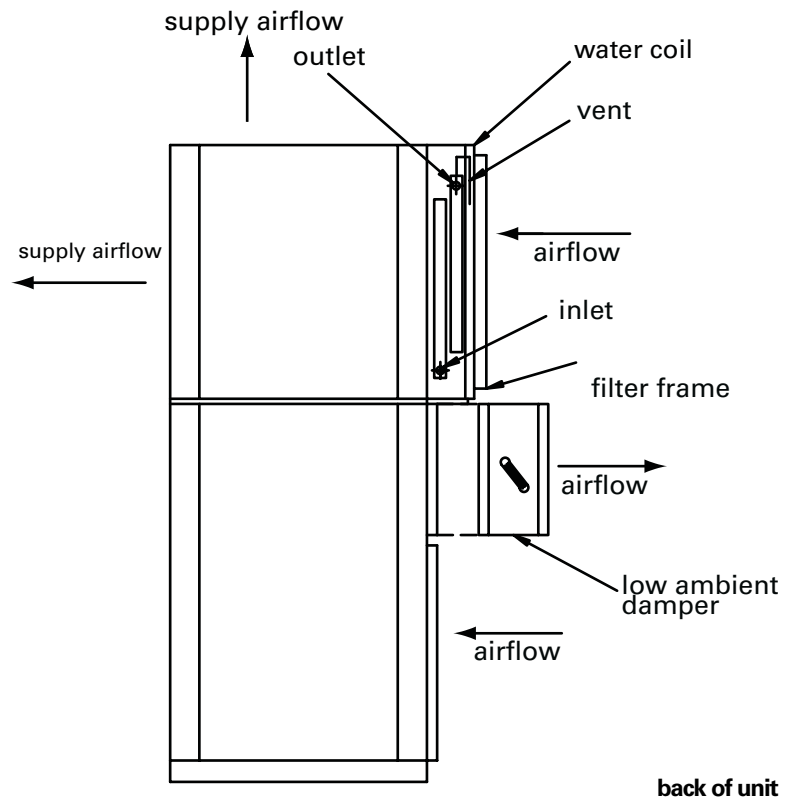

Installation

dimensions and weights

SCIH Accessories

Plenum

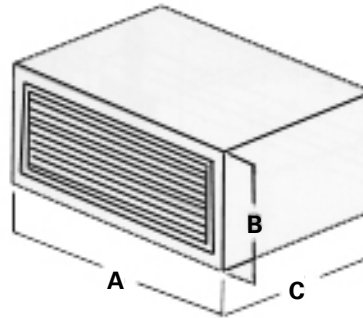

SCIH Plenum Dimensions & Weight, in-lbs.

Unit Size	A	B	C	Grill Size (W x H)	Weight
5 ton	42 ³ / ₄	16 ¹ / ₄	31 ¹ / ₂	38 ³ / ₄ x 12 ³ / ₄	76
7.5 ton	56 ³ / ₄	16 ¹ / ₄	31 ¹ / ₂	52 ³ / ₄ x 12 ³ / ₄	95
10 & 15 ton	85 ⁷ / ₈	16 ¹ / ₄	31 ¹ / ₂	81 ⁷ / ₈ x 12 ³ / ₄	141

Low Ambient Damper

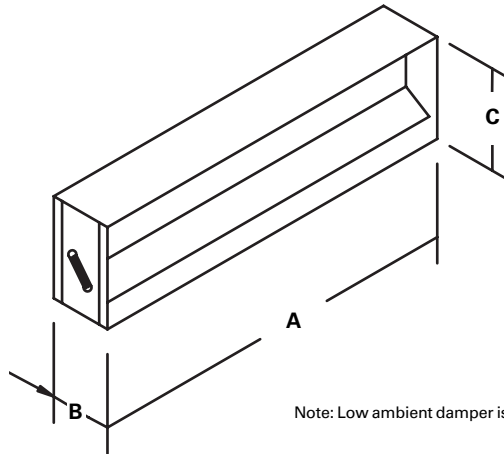

Note: Low ambient damper is field-installed.

SCIH Low Ambient Damper Dimensions & Weight, in-lbs.

Unit Size	A	B	C	Weight
5 & 7.5 ton	19 ¹ / ₈	7 ⁷ / ₈	11	20
10 & 15 ton	52 ³ / ₄	7 ⁷ / ₈	11	40

Installation

dimensions and weights

Hot Water Coil

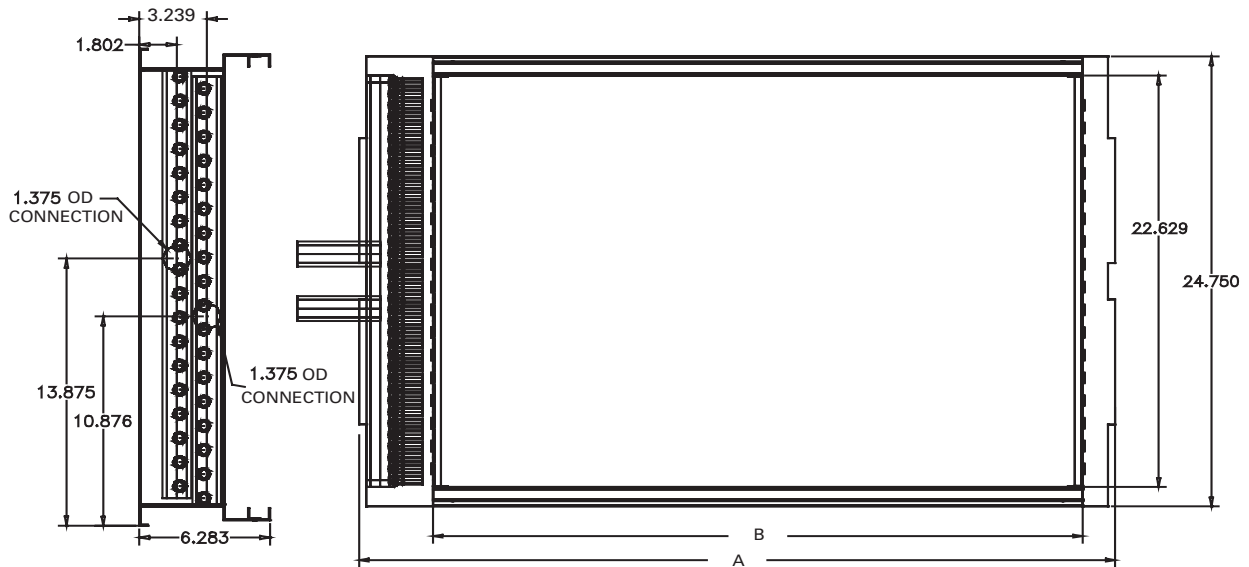

SCIH Hot Water Coil Dimensions & Weight, in-lbs.

Unit Size	A	B	Wet Coil Weight	Dry Coil Weight
5Ton	38 1/2	33 1/16	49	39
7.5 Ton	52 1/2	47 1/16	63	50
10 & 15 Ton	81 5/8	76 1/4	96	75

Notes:

1. Coils are field-installed.
2. Coil connections are mirror-image and can be mounted with either left or right-hand connections.

Steam Coil

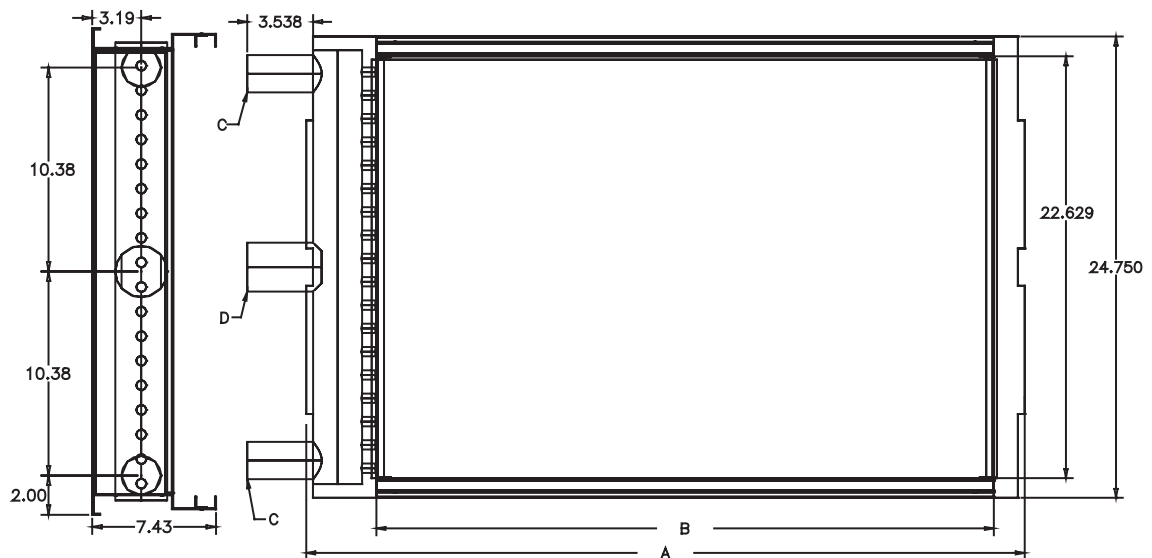

SCIH Steam Coil Dimensions & Weights, in-lbs.

Unit Size	A	B	return C	supply D	Weight
5Ton	38 1/2	31 7/8	1 1/2	2	55
7.5 Ton	52 1/2	45 7/8	1 1/2	2	68
10 & 15 Ton	81 5/8	74	2	3	93

Notes:

1. Coils are field-installed.
2. Coil connections are mirror-image and can be mounted with either left or right-hand connections.

Installation

mechanical requirements

Ductwork Considerations

Install all air ducts according to the National Fire Protection Association standards for the "Installation of Air Conditioning and Ventilation Systems other than Residence Type (NFPA 90A) and Residence Type Warm Air Heating and Air Conditioning Systems (NFPA 90B).

Make duct connections with a flexible material such as heavy canvas. If a fire hazard exists, Trane recommends using Flexweave 1000, type FW30 or equivalent canvas. Use **three inches** for the discharge duct and **three inches** for the return duct. Keep the material loose to absorb unit vibration.

Run the ductwork as far as possible without changing size or direction. Do not make abrupt turns or transitions near the unit due to increased noise and excessive static losses. Use elbows with splitters or turning vanes to minimize static losses.

Poorly constructed turning vanes may cause airflow generated noise. Check total external static pressures against fan characteristics to be sure the required airflow is available throughout the ductwork.

Direct louvers up and down for condensers air discharge and intake so as to not short circuit condenser air. Pitch outdoor ducts away from unit to protect unit from rain and snow entering with condenser air. Auxiliary louvers and hoods may be required for this purpose. Attach ducts to unit with canvas section duct connectors or other suitable noise and vibration absorbing devices.

WARNING

Hazardous voltage!

Disconnect all electric power, including remote disconnects before servicing. Follow proper lockout/tagout procedures to ensure the power can not be inadvertently energized. Failure to disconnect power before servicing could result in death or serious injury.

electrical requirements

Installation

⚠ WARNING

Ground Wire!

All field-installed wiring must be completed by qualified personnel. All field-installed wiring must comply with NEC and applicable local codes. Failure to follow this instruction could result in death or serious injury.

⚠ WARNING

Grounding Required!

Follow proper local and state electrical code on requirements for grounding. Failure to follow code could result in death or serious injury.

Electrical Requirements

Follow these guidelines, referring to unit wiring diagrams and supply power dimensional information to ensure correct electrical requirements at the installation site. Reference supply power wiring locations on unit submittals or in the "Dimensions and Weights" section. Specific unit wiring diagrams are provided on each unit. Use these diagrams for connections or trouble analysis.

⚠ WARNING

Hazardous voltage!

Disconnect all electric power, including remote disconnects before servicing. Follow proper lockout/tagout procedures to ensure the power can not be inadvertently energized. Failure to disconnect power before servicing could result in death or serious injury.

Supply Power Wiring

It is the installer's responsibility to provide power supply wiring to the unit. Wiring should conform to NEC and all applicable code requirements. To ensure the unit supply power wiring is properly sized and installed, follow the guidelines below:

1. Verify the power supply available is compatible with the unit nameplate ratings. The supply power must be within 10% of the rated voltage listed on the unit nameplate.
2. Reference the electrical data in Table I-ED-1. Protect the electrical service from over current and short circuit conditions in accordance with NEC requirements. Size protection devices according to the electrical data on the unit nameplate.
3. If using a field-supplied disconnect, install it at or near the unit in accordance with NEC. **Do not mount a field-supplied disconnect on the unit.** Reference the electrical service entrance location on unit submittals.
4. Complete the unit power wiring connections onto either the main terminal block or the field-provided non-fused disconnect switch.
5. Provide proper unit grounding in accordance with local and national codes.

Electrical Data Calculations

RLA = Rated Load Amps
 Compressor LRA = Locked Rotor Amps
 Fan Motor LRA = Locked Rotor Amps,
 N.E.C. Table 430 - 151
 FLA = Full Load Amps, N.E.C.
 Table 430 - 150

Voltage utilization range is ± 10 percent

Determination of Minimum Circuit Ampacity (MCA)

MCA = $1.25 \times$ largest motor amps (FLA or RLA) + the sum of the remaining motor amps.

Determination of Maximum Fuse Size (MFS)

MFS = $2.25 \times$ largest motor amps (FLA or RLA) + the sum of the remaining motor amps.

If the rating value determined does not equal a standard current rating of over current protective device, use the next lower standard rating for the marked maximum rating.

⚠ WARNING

Live electrical components!

During installation, testing, servicing and troubleshooting of this product, it may be necessary to work with live electrical components. Have a qualified licensed electrician or other individual who has been properly trained in handling live electrical components perform these tasks. Failure to follow all electrical safety precautions when exposed to live electrical components could result in death or serious injury.

Voltage Imbalance

Voltage imbalance on three-phase systems can cause motor overheating and premature failure. Maximum allowable imbalance is 2.0%, and the readings used to determine it must be measured at the compressor terminals.

Voltage imbalance is defined as 100 times the sum of the division of the three voltages from the average voltage. If, for example, the three measured voltages are 221, 230, 227, the average would be:

$$\frac{(221+230+227)}{3} = 226 \text{ volts}$$

The percentage of voltage imbalance is then:

$$\frac{100 \times (226 - 221)}{226} = 2.2\%$$

In this example, 2.2 percent imbalance of more than 2.0 percent exists, be sure to check the voltage at the unit disconnect and terminal block switch. If an imbalance at the unit disconnect switch does not exceed 2.0 percent, the imbalance is caused by faulty wiring within the unit. Be sure to conduct a thorough inspection of the unit electrical wiring connections to locate the fault, and make any repairs necessary.



Installation

electrical requirements

Table I-ER-1. Integral Air-Cooled Standard Motor Electrical Data

Unit Size	Voltage	Compressor		Condenser Fan Motor		Evaporator Fan Motor		MCA	MFS
		RLA	LRA	Hp	FLA	Hp	FLA		
5	208-230/60/3	19.3	135.0	1.5	4.42	1.0	3.15	31.7	50
	460/60/3	8.2	61.8		2.00		1.42	13.7	20
	575/60/3	6.6	49.4		1.60		1.14	11.0	15
75	208-230/60/3	25.0	179.0	2.0	5.81	1.5	4.42	41.5	60
	460/60/3	12.0	101.0		2.63		2.00	19.6	30
	575/60/3	9.8	74.0		2.10		1.60	16.0	25
10	208-230/60/3	19.3	135.0	2.0	5.81	2.0	5.81	55.0	70
	460/60/3	8.2	61.8		2.63		2.63	23.7	30
	575/60/3	6.6	49.4		2.10		2.10	19.1	25
15	208-230/60/3	25.0	179.0	5.0	13.70	3.0	8.32	78.3	100
	460/60/3	12.0	101.0		6.18		3.76	36.9	45
	575/60/3	9.8	74.0		4.94		3.01	30.0	35

Notes:

1. Voltage range: nominal voltage: 208-230V, acceptable range: 187 - 253V, nominal voltage: 380V, acceptable range: 342 - 416V, nominal voltage: 460V, acceptable range: 414 - 506V, nominal voltage: 575V, acceptable range: 518 - 633V
2. Ampacity = (1.25 x compressor RLA) + the sum of the second compressor RLA (is used) and all other motor FLAs
3. MFS = (2.25 x compressor RLA) + the sum of the second compressor RLA (if used) and all other motor FLAs

Table I-ER-2. Integral Air-Cooled Oversized Motor Electrical Data

Unit Size	Voltage	Compressor		Condenser Fan Motor		Evaporator Fan Motor		MCA	MFS
		RLA	LRA	Hp	FLA	Hp	FLA		
5.0	208-230/60/3	19.3	135.0	2.0	5.81	1.5	4.42	34.4	50
	460/60/3	8.2	61.8		2.63		2.00	14.9	20
	575/60/3	6.6	49.4		2.10		1.60	12.0	15
75	208-230/60/3	25.0	179.0	3.0	8.32	2.0	5.81	45.4	70
	460/60/3	12.0	101.0		3.76		2.63	21.4	30
	575/60/3	9.8	74.0		3.01		2.10	17.4	25
10.0	208-230/60/3	19.3	135.0	3.0	8.32	3.0	8.32	60.1	70
	460/60/3	8.2	61.8		3.76		3.76	26.0	30
	575/60/3	6.6	49.4		3.01		3.01	20.9	25
15.0	208-230/60/3	25.0	179.0	7.5	19.80	5.0	13.70	89.8	100
	460/60/3	12.0	101.0		8.96		6.18	42.1	50
	575/60/3	9.8	74.0		7.17		4.94	34.2	40

Notes:

1. Voltage range: nominal voltage: 208-230V, acceptable range: 187 - 253V, nominal voltage: 460V, acceptable range: 414 - 506V, nominal voltage: 575V, acceptable range: 518 - 633V
2. Ampacity = (1.25 x compressor RLA) + the sum of the second compressor RLA (is used) and all other motor FLAs
3. MFS = (2.25 x compressor RLA) + the sum of the second compressor RLA (if used) and all other motor FLAs

Installation

Installation Procedure

Installation Checklist

The checklist listed below is a summary of the steps required to successfully install an integral air-cooled unit. This checklist is intended to acquaint the installing personnel with what is required in the installation process. It does not replace the detailed instructions detailed in the applicable sections of this manual.

⚠ WARNING

Hazardous voltage!

Disconnect all electric power, including remote disconnects before servicing. Follow proper lockout/tagout procedures to ensure the power can not be inadvertently energized. Failure to disconnect power before servicing could result in death or serious injury.

General Unit Requirements

- Install and secure the ductwork to the unit.
- Check unit for shipping damage and material shortage. Refer to the Receiving Checklist.

Electrical Requirements

- Verify that the electrical power supply characteristics comply with the unit nameplate specifications.
- Inspect all control components; tighten any loose connections.
- Connect properly sized and protected power supply wiring to a field supplied/ installed disconnect and unit power terminal block, or to the optional unit mounted disconnect switch.
- Properly ground the unit.

Field Installed Control Wiring (Optional)

- Complete the field wiring connections.

Note: All field installed wiring must comply with NEC and applicable local codes.

Fan Discharge Conversion

Refer to Figure I-IP-1 and Table I-IP-1 while following the steps below to convert the fan discharge from vertical to horizontal.

1. Remove the front and top fan section panels.
2. Loosen the fan motor to release belt tension. Remove the fan belt. Do not force the belt over sheaves.

3. Remove the bolts holding the fan scroll to support channels. Lift fan out through the front of the unit.
4. Move the fan sheave to the opposite end of the fan shaft.
5. Turn the fan scroll end-for-end and bolt it to the support channels with the discharge towards the back. Mounting holes are provided in the fan scroll.
6. Align the fan and motor sheaves. Install the belt and adjust the belt tension. Refer to Table I-IP-1 for the correct belt size. The belt should depress about one inch under light pressure when properly adjusted.
7. Reverse direction of the motor rotation by exchanging any two of the three motor wire connections.
8. Exchange the front and top panel locations.

Table I-IP-1. Belt sizes for fan discharge conversion

model	discharge	
	horizontal	vertical
SCIH050	A-34	A-42
SCIH075	A-34	A-42
SCIH100	B-35	B-42
SCIH150	B-30	B-38

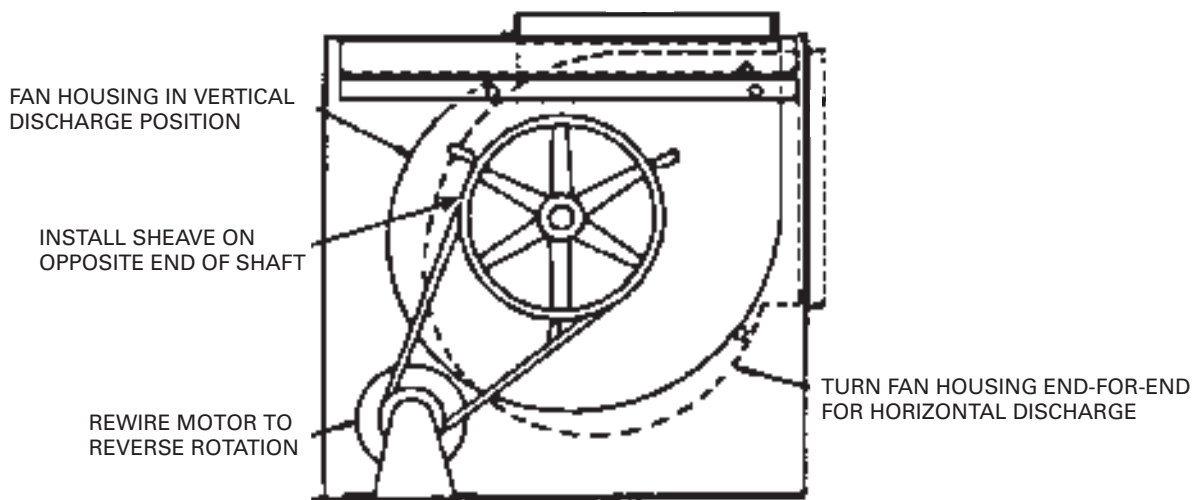

Figure I-IP-1. Converting fan to horizontal discharge

Installation

Installation Procedure

Low Ambient Damper Installation

Reference Figure I-IP-2 and follow the procedure below to install the low ambient damper option.

1. Using a 1" hole saw, make a hole on the right side of the condenser fan discharge panel as shown. Install a 1" bushing into the hole.

2. Apply the soft gasket material provided around the damper as shown.
3. Place the damper over the discharge opening using the screws ($\frac{3}{16} \times \frac{5}{8}$ ") provided. See Detail A.
4. Install the damper actuator, which was previously assembled to the mounting bracket, to the right panel of the damper using the four screws ($\frac{1}{4} \times \frac{5}{8}$ ")

5. Connect the capillary tube to the pressure operator using the flare fitting. Insert the tube through bushing referenced in step 1. Route the capillary tube to the liquid line on circuit #1.
6. Remove the end cap from the access valve and attach to the end of the capillary tube.

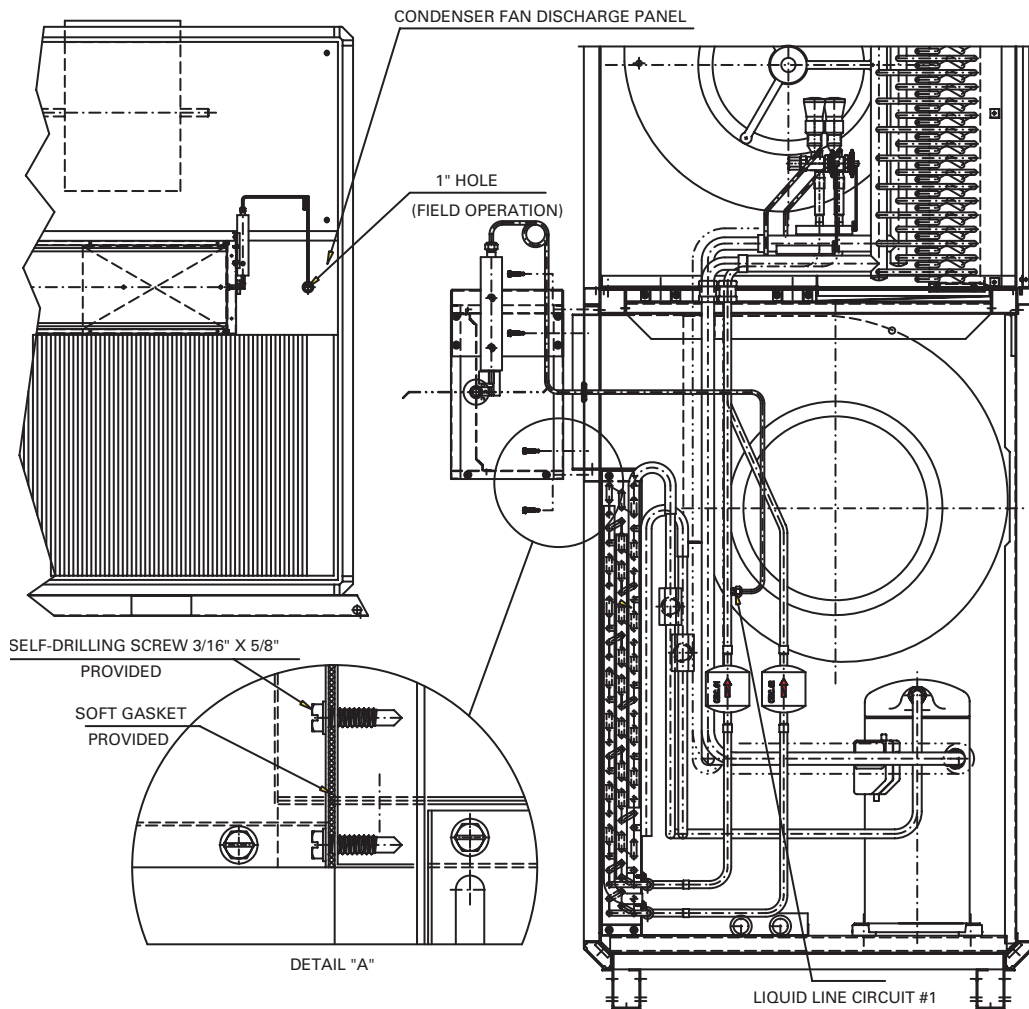

Figure I-IP-2. Low ambient damper installation

Installation

Installation Procedure

Hydronic Coil Installation

Reference Figure I-IP-3 and follow the procedure below to install the hydronic coil.

1. Remove the front grill, filters, two upper frame screws, and two lower frame screws.
2. Install the hydronic coil in the space previously occupied by the grill.
3. Use the frame screws and one of the grill screws to clamp the coil end supports between the unit frame and the mounting brackets (supplied with the coil).
4. Slide the filters in the filter rack from either end of the coil.
5. Adjust the filter rack for 2-inch filters by

removing the upper and lower filter support brackets.

6. The hydronic coil can be installed for either right or left-hand connections. However, steam coils must have the condensate lines connected to the bottom outlet, with the top outlet capped.
7. A heating coil control relay is factory provided to use with BAY28X182 and BAY28X183 thermostats. Drill two $\frac{5}{32}$ " holes $\frac{7}{16}$ " apart and mount the relay in the unit control box as shown in the detail drawing below. Use a 6-32X.31 screw (not included) to mount the relay. Connect wiring in accordance with the thermostat wiring diagram.

CONTROL BOX DETAIL

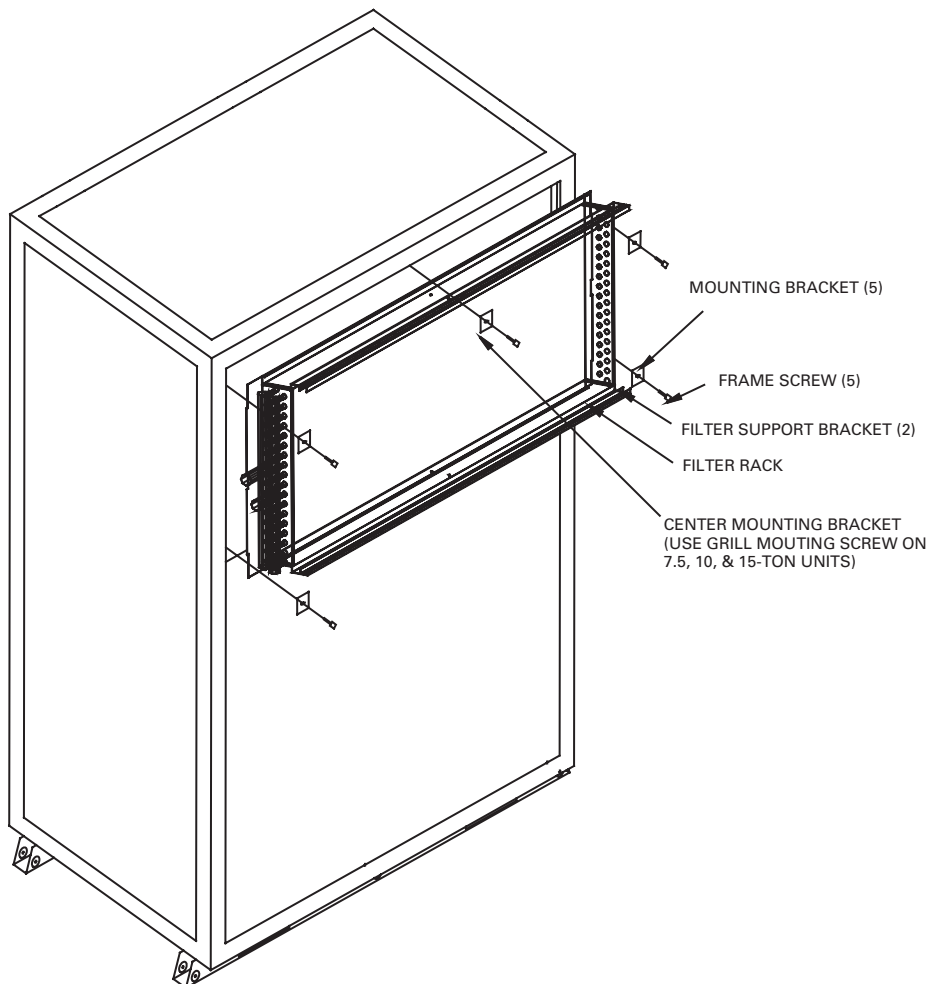
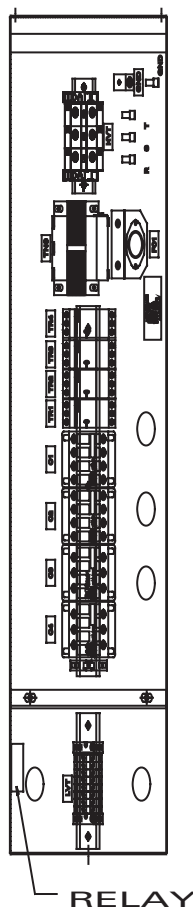

Figure I-IP-3. Hydronic coil installation

Installation

Installation Procedure

Plenum Installation

Reference Figure I-IP-4 and follow the procedure below to install the plenum.

1. Before installing the plenum, ensure the evaporator fan is in the discharge position. If not, see the fan discharge conversion procedure on page 16.
2. Apply the soft gasket material provided completely around the top of the unit frame as shown in the detail drawing.

3. Tighten the screws provided as shown. Use screws on the rear, right, and left sides through the pilot holes on the plenum panels.
4. After the plenum is installed, adjust the motor pulley for the correct airflow and discharge grille for the correct airflow direction.

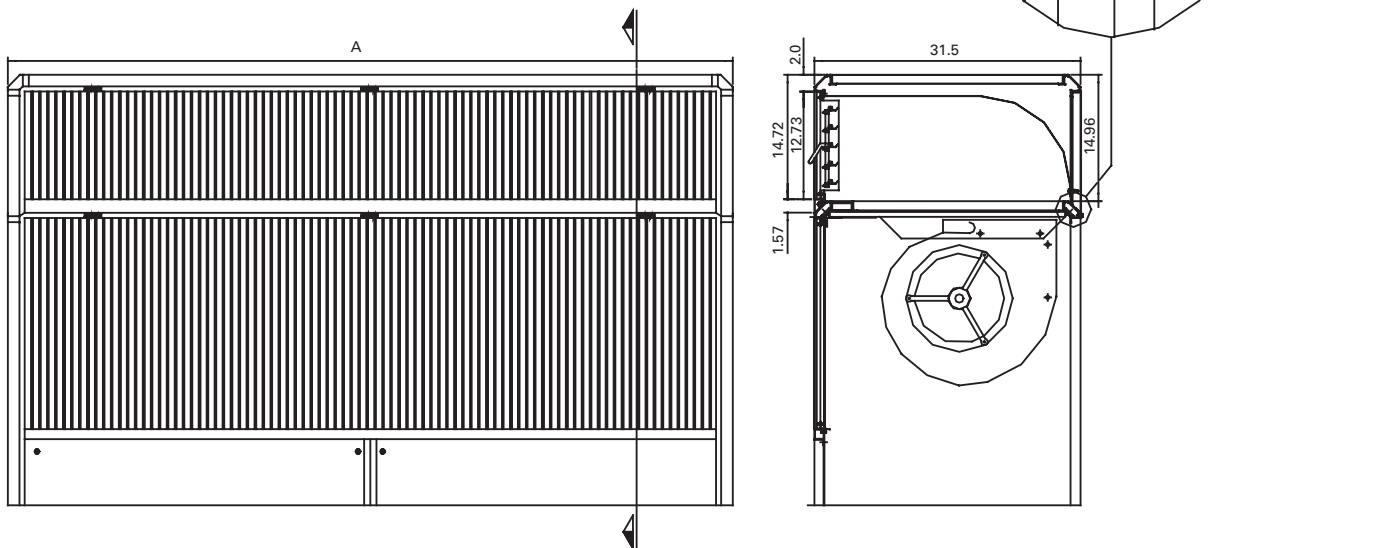

Figure I-IP-4. Plenum installation

Installation

Pre-Startup Requirements

Pre-Startup Checklist

Complete this checklist after installing the unit to verify all recommended installation procedures are complete before unit startup. This does not replace the detailed instructions in the appropriate sections of this manual. Always read the entire section carefully to become familiar with the procedures.

WARNING

Hazardous voltage!

Disconnect all electric power, including remote disconnects before servicing. Follow proper lockout/tagout procedures to ensure the power can not be inadvertently energized. Failure to disconnect power before servicing could result in death or serious injury.

Receiving

- Inspect unit and components for shipping damage. File damage claims immediately with the delivering carrier.**
- Check nameplate unit data so that it matches the sales order requirements.
- Check unit for missing material. Look for ship-with accessories that are packaged separately and placed inside the access panel, fan section, or compressor section. See the "Receiving and Handling" section on page 6.

Unit Location

- Ensure the unit location is adequate for unit dimensions, ductwork, piping, and electrical connections.
- Ensure access and maintenance clearances around the unit are adequate. See the "Service Access" section on page 7.

Unit Mounting

- Remove shipping brackets on the compressor assembly and supply fan.

Component Overview

- Verify the fan and motor sheaves are aligned.
- Check the belt tension for proper adjustment.
- Ensure the fan rotates freely.
- Tighten locking screws, bearing set screws and sheaves.
- Ensure bearing locking collars do not wobble when rotated.
- Ensure all air filters are properly installed with consideration of size and air flow.
- Manually rotate the condenser and evaporator fans to ensure free movement. Verify that all of the fan mounting hardware is tight.

Ductwork

- Verify that all ductwork conforms to NFPA 90A or 90B and all applicable local codes.

Installation

Startup

Unit Startup Procedures

 **WARNING**

Hazardous voltage!

Disconnect all electric power, including remote disconnects before servicing. Follow proper lockout/tagout procedures to ensure the power can not be inadvertently energized. Failure to disconnect power before servicing could result in death or serious injury.

1. Check all electrical connections for tightness.
2. Be sure all unit accessories are properly set and installed.
3. Inspect all ductwork and duct connections.
4. Check for proper belt tension.
5. Check fan drive sheaves, pulleys, and bearings.

Unit Startup Checklist

1. Set thermostat to Off position
2. Engage power supply by closing power disconnect
3. Switch thermostat to fan position and adjust temperature setting below room temperature. Evaporator fan should start.
4. Check evaporator section for proper operation
5. Switch thermostat to cool position and adjust temperature setting to below room temperature. The evaporator fan, condenser fan(s), and compressor(s) should start.

Note: These units are equipped with high efficiency scroll compressors. Check for proper scroll rotation prior to operating this unit.

 **WARNING**

Rotating Components!

During installation, testing, servicing and troubleshooting of this product it may be necessary to measure the speed of rotating components. Have a qualified or licensed service individual who has been properly trained in handling exposed rotating components, perform these tasks. Failure to follow all safety precautions when exposed to rotating components could result in death or serious injury.

6. Check condenser fan for proper rotation. If fan rotation is incorrect, switch thermostat to Off position and disconnect power. Reverse two phase leads at disconnect and return back to Step 1 of startup.
7. Allow unit to run until all system temperatures and pressures stabilize.
8. Check systems for proper operation and performance. Observe unit in operation and check for unusual noise, vibration, belt and fan clearances.

Operation

Sequence of Operation

Sequence of Operation

The thermostat controls the unit operation. It has both manual and automatic switches so the thermostat maintains desired comfort levels.

The fan switch allows manual selection of the fan speed using the On or Auto setting. With the switch set in the On position, the evaporator fan runs continuously, independent from the thermostat temperature setting. The Auto position cycles the evaporator fan on and off with the demand for heating or cooling.

The system switch may have two or more positions. For example, using a cooling only thermostat, the system switch can be set in the Off or the Cool position. The Off position disconnects power from the thermostat contacts that control the condensing unit. This prevents

the condensing unit from running, regardless of the thermostat temperature setting. The evaporator fan may circulate air if the fan switch is in the On position. With the switch in the Cool position the condensing unit and evaporator will operate on a signal from the thermostat calling for cooling.

With the fan switch set to Auto and the system switch set to Cool, the following sequence takes place. On a rise in room temperature, the thermostat contacts close to provide power to the evaporator fan contactor, the condensing unit fan contactor, and the condensing unit compressor contactors. As the room temperature reaches setpoint, the thermostat contacts open to de-energize all contactors, and the system cycles off. This system will remain off until additional cooling is required and the cycle repeats.

Table OS-O-1. Normal Operating Conditions

high pressure	200 to 340 psig
low pressure	54 to 80 psig
superheat	8 to 12°C
subcooling	5 to 10°C
liquid sightglass	refrigeration flow with no gas traces
current	must not surpass the rated current

Table O-OS-2. Controls Adjustment

Control	Disarming	Rearming
High pressure control	395 +/- 15 psig	280 +/- 20 psig
Low pressure control	25 +/- 8 psig	80 +/- 12 psig
Limit low pressure control	10 +/- 3 psig	35 +/- 5 psig
Motor windings thermostat	105°C	82°C



Maintenance

general information

Table M-GI-1. Integral Air-Cooled General Data

Nominal Tons	5	7.5	10	15
ARI capacity - btu/h	60,600	91,000	121,900	177,200
(S)EER	10.47 ¹	10.36	10.38	9.76
R22 charge/circuit (lbs.)	9.2	14.3	9.3	11.7
Shipping weight - lbs.		908	1087	1495
Operating weight - lbs.		848	1027	1445
Compressor, qty - hp	1	1	2	2
Circuits	1	1	2	2
Condenser				
Face area, sq/ ft.	6.74	10.75	16.55	16.55
Rows / fpf	4 / 180	4 / 168	3 / 180	4 / 180
Fans, qty.	1	1	2	2
Fan size, in.	15x15	15x15	15x15	15x15
Motor hp	1.5	2.0	2.0	5.0
Evaporator				
Face area, sq. ft	5.99	8.32	12.82	12.82
Rows / fpf	4 / 144	4 / 144	4 / 144	4 / 144
Filter qty. - size, in.	2 - 23.7x18	2 - 23.7x25	3 - 23.7x25.6	3 - 23.7x25.6
Fans qty. - size, in	1 - 12x12	1 - 12x12	2 - 12x12	2 - 12x12
Motor hp	1.0	1.5	2.0	3.0
Min. airflow	1800	2700	3600	5400
Max. airflow	2200	3300	4400	6600

Notes: 1. Net cooling capacity is rated at 95°F ambient, 80°F entering dry bulb and 67°F entering wet bulb at scfm air condition. 2. EER is rated at ARI conditions.

Footnote 1. SEER applies to 5-ton unit--ARI 210-240 Certified.

maintenance procedures

Maintenance

Maintenance Procedures

Before beginning any maintenance procedures heed all warnings and cautions.

⚠ WARNING

Hazardous voltage!

Disconnect all electric power, including remote disconnects before servicing. Follow proper lockout/tagout procedures to ensure the power can not be inadvertently energized. Failure to disconnect power before servicing could result in death or serious injury.

Periodic Maintenance Checklist

- Inspect coil surface for cleanliness. Clean as required. Refer to "Coil Cleaning" under "Maintenance Procedures."

Annual Maintenance Checklist

- Perform all monthly maintenance inspections.
- Perform seasonal startup checks.
- Leak test refrigerant circuits. Inspect contacts of fan motor contactors and relays. Replace all worn contacts.
- Clean condenser fans.
- Clean and repaint any corroded surface.

Periodic Maintenance Procedures

This section describes specific maintenance procedures that must be performed as a part of the normal maintenance program for this unit. Be certain to disconnect electrical power to the unit before performing these procedures.

Note: the following coil cleaning procedures apply only to the outdoor condensers. Do not use these procedures for the reheat or evaporator coils.

Cleaning the Condenser Coils

Clean the coil at least once each year or more frequently if located in a dirty environment, to help maintain proper unit operating efficiency. High discharge pressures are a good indication that the coil needs cleaning. Follow the detergent

manufacturer instructions as closely as possible to avoid potential damage to the coil.

⚠ WARNING

Hazardous chemicals!

Coil cleaning agents can be either acidic or highly alkaline. Handle chemicals carefully. Proper handling should include goggles or face shield, chemical resistant gloves, boots, apron or suit as required. For personal safety refer to the cleaning agent manufacturer's Materials Safety Data Sheet and follow all recommended safe handling practices. Failure to follow all safety instructions could result in death or serious injury.

To clean the refrigerant coil, use a soft brush and sprayer, such as a garden pump up or high pressure type. In addition, use a quality detergent; like "SPREX AC", "OAKITE 161" or "OAKITE 166" and "COILOX."

Note: If detergent is strongly alkaline (i.e. has a pH value greater than 8.5) after mixing, an aluminum corrosion inhibitor must be added.

Coil Cleaning Procedure

⚠ WARNING

Hazardous voltage!

Disconnect all electric power, including remote disconnects before servicing. Follow proper lockout/tagout procedures to ensure the power can not be inadvertently energized. Failure to disconnect power before servicing could result in death or serious injury.

1. Disconnect power to the unit.
2. Remove panels from the unit to gain access to the coil.
3. Use a soft brush to remove loose dirt

- and debris from both sides of the coil.
4. Straighten coil fins with fin comb as required.
5. Mix the detergent with water according to the manufacturers instructions.

Observe all recommendations of the cleanser manufacturer. The coil cleanser manufacturer's recommendations, warnings and cautions will at all times take precedence to these instructions.

1. Place solution in the sprayer. Be sure to follow these guidelines if using a high-pressure sprayer:
 - a) Minimum nozzle spray angle is 15°.
 - b) Spray solution at a 90° angle to the coil face.
 - c) Keep sprayer nozzle at least six inches from the coil.
 - d) Sprayer pressure must not exceed 600 psi.
2. Spray leaving air side of the coil first then spray the entering air side of the coil. Allow the detergent and water solution to stand on the coil for five minutes.
3. Rinse both sides of the coil with cool, clean water.
4. Inspect the coil. If it still appears dirty, repeat the cleaning procedure.
5. Reinstall all unit components and panels, and restore electrical power and gas supply to the unit.

Maintenance

Refrigerant System

Follow the Trane recommended procedures on operation, maintenance, and service to ensure refrigerant conservation and emission reduction.

Also, pay specific attention to the following:

- Whenever removing refrigerant from air conditioning or refrigerating equipment, recover for reuse, recycle, reprocess (reclaim), or properly destroy it.
- Always determine possible refrigerant recycling or reclaiming requirements before beginning recovery. Questions about recovered refrigerants and acceptable refrigerant quality standards are addressed in ARI Standard 700.
- Use approved containment vessels and safety standards. Comply with all applicable transportation standards when shipping refrigerant containers.
- To minimize emissions while recovering refrigerant, use recycling equipment. Always attempt to use methods which will pull the lowest possible system vacuum while recovering and condensing refrigerant into containment.
- When leak checking, be aware of any new leak test methods which eliminate refrigerant as a trace gas.
- When cleaning system components or parts, do not use CFC11 (R11) or CFC113 (R113). Refrigeration system clean up methods using filters and dryers are recommended. Do not use solvents which have ozone depletion factors. Properly dispose of used materials.
- Take extra care to properly maintain all service equipment directly supporting refrigerant service work such as gauges, hoses, vacuum pumps, and recycling equipment.
- Stay aware of unit enhancements, conversion refrigerants, compatible parts, and manufacturer's recommendations that will reduce refrigerant emissions and increase equipment operating efficiencies. Follow specific manufacturer's guidelines for conversion of existing systems.

- To assist in reducing power generation emissions, always attempt to improve equipment performance with improved maintenance and operations that will help conserve energy resources.

Refrigerant Leak Testing

WARNING

Confined space hazard!

Do not work in confined spaces where sufficient quantities of a refrigerant or other hazardous, toxic or flammable gas may be leaking. Refrigerant or other gases could displace available oxygen to breathe, causing possible asphyxiation or other serious health risks. Some gases may be flammable and or explosive. Evacuate the area immediately and contact the proper rescue or response authority. Failure to take appropriate precautions or to react properly to a potential hazard could result in death or serious injury.

WARNING

Explosion hazard!

Use only dry nitrogen with a pressure regulator for pressurizing unit. Do not use acetylene, oxygen or compressed air or mixtures containing them for pressure testing. Do not use mixtures of a hydrogen containing refrigerant and air above atmospheric pressure for pressure testing as they may become flammable and could result in an explosion. Refrigerant, when used as a trace gas should only be mixed with dry nitrogen for pressurizing units. Failure to follow these recommendations could result in death or serious injury or equipment or property-only damage.

In the event of required system repair, leak test the liquid line, evaporator coil, and suction line at pressures dictated by local codes, and using the following guidelines.

1. Charge enough refrigerant and dry nitrogen into the system to raise the pressure to 100 psig.
2. Use a halogen leak detector, halide torch, or soap bubbles to check for leaks. Check interconnecting piping joints, the evaporator coil connections, and all accessory connections.
3. If a leak is detected, release the test pressure, break the connections and reassemble it as a new joint, using proper brazing techniques.
4. If no leak is detected, use nitrogen to increase the test pressure to 150 psig and repeat the leak test. Also, use soap bubbles to check for leaks when nitrogen is added.
5. Retest the system to make sure new connections are solid.
6. If a leak is suspected after the system has been fully charged with refrigerant, use a halogen leak detector, halide torch, or soap bubbles to check for leaks.

Refrigerant Evacuation

For field evacuation, use a rotary style vacuum pump capable of pulling a vacuum of 100 microns or less.

When connecting the vacuum pump to a refrigeration system, it is important to manifold the pump to both the high and low side of the system. Follow the pump manufacturer's directions.

Maintenance

maintenance procedures

CAUTION***Compressor damage!***

Do not use a Meg ohm meter or apply power to the winding of a compressor while it is under a deep vacuum. This may damage the motor windings.

 **WARNING*****Hazardous pressure!***

If heat is required to raise the refrigerant pressure during refrigerant removal, use only warm water or heat blankets. Do not exceed 150°F. Do not apply a direct flame to the refrigerant container. Failure to follow these safety precautions can result in a violent explosion, which could result in death or serious injury.

Charging the Refrigerant System

To completely charge the system, charge gaseous refrigerant into the suction line schrader valve with the unit running. However, make sure that some refrigerant is present in each circuit before starting the compressors.

CAUTION***Compressor damage!***

Do not allow liquid refrigerant to enter the suction line. Excessive liquid may damage the compressor.

CAUTION***Compressor damage!***

Never manually or automatically pump down below 7 psig. This may cause the compressor to operate in a vacuum and cause compressor damage.

Maintenance

periodic checklists

Periodic Checklists

Monthly Checklist

The following checklist provides the recommended maintenance schedule to keep the unit running efficiently.

 **WARNING**

Hazardous voltage!

Disconnect all electric power, including remote disconnects before servicing. Follow proper lockout/tagout procedures to ensure the power can not be inadvertently energized. Failure to disconnect power before servicing could result in death or serious injury.

-
1. Inspect unit air filters. Clean or replace if airflow is blocked or if filters are dirty.
 2. Inspect coils for icing. Icing on the coils may indicate low airflow supply, restricted airflow from dirty fins.
 3. Check the fan belt condition and tension. Adjust tension if belt is floppy or squeals continually.
 4. Check and record operating pressures.

Semi-Annual Maintenance

1. Verify the fan motor is properly aligned and bolted tight to the motor frame.
2. Lubricate fan bearings.
3. With power disconnected, manually rotate the fan wheel to check for obstructions in the housing or interference with fan blades. Remove obstructions and debris. Center the fan wheel if necessary.
4. Check the fan assembly sheave alignment. Tighten set screws to their proper torques.

Note: Perform this procedure monthly if the unit is in a coastal or corrosive environment.

Annual Maintenance

Check and tighten all set screws, bolts, locking collars and sheaves.

1. Inspect, clean, and tighten all electrical connections.
2. Visually inspect the entire unit casing for chips or corrosion. Remove rust or corrosion and repaint surfaces.
3. Visually check for leaks in refrigerant piping.
4. Inspect fan, motor, and control contacts. Replace badly worn or eroded contacts.
5. Inspect the thermal expansion valve sensing bulbs for cleanliness, good contact with the suction line, and adequate insulation from ambient air.

 **WARNING**

Live electrical components!

During installation, testing, servicing and troubleshooting of this product, it may be necessary to work with live electrical components. Have a qualified licensed electrician or other individual who has been properly trained in handling live electrical components perform these tasks. Failure to follow all electrical safety precautions when exposed to live electrical components could result in death or serious injury.

Maintenance

maintenance procedures

Troubleshooting

Use the following steps and procedures to help correct these common problems.

WARNING

Hazardous voltage!

Disconnect all electric power, including remote disconnects before servicing. Follow proper lockout/tagout procedures to ensure the power can not be inadvertently energized. Failure to disconnect power before servicing could result in death or serious injury.

Problem

The entire unit does not operate.

Possible cause

1. Power interruption
2. Thermostat not operating
3. Electrical panel: a) 24-volt transformer defective; b) loose wire

Remedy

1. Check for blown fuses or tripped circuit breakers. Replace or reset if necessary.
2. Setting may be too high; check unit and reset. Thermostat may be out of calibration or otherwise defective; replace.
3. Correct as required.

Problem

Fan runs but compressor does not start.

Possible cause

1. Low voltage
2. Remote thermostat
3. Compressor contactor open or burned
4. High pressure control cutting out unit
5. Refrigerant leak - no gas
6. Loose or defective wires.
7. Compressor shorted, open or burned
8. Defective compressor

Remedy

1. Check power supply for voltage outside the acceptable voltage range.
2. Check the control unit for loose wires. Firm any loose connections.
3. Replace.
4. Check for loose wire connection, broken or burned contacts. If defective, replace.
5. Locate leak and repair. Recharge unit.
6. Tug on wires to see if they will separate from connections. Replace terminals if necessary.
7. Check for shorts, opens, and grounded. Remove and replace compressor.
8. Remove and replace.

Problem

Unit held off by safety.

Possible cause

1. Unit cutout on high pressure control, set at 385 psig
2. Refrigerant leak
3. Air restriction, dirty coils
4. Partial restriction in refrigerant system
5. High pressure control
6. TXV power element charge loss
7. Loose connection in electrical unit

Remedy

1. Verify the airflow is uninterrupted. Also, verify that the low ambient damper is set properly, allowing condensing temperatures of 90–135°F. Reset high pressure switch to start.
2. See if unit is low on refrigerant charge. Repair leak and recharge unit.
3. Verify if the air filter is dirty or has an airflow restriction, and correct problem.
4. Locate restriction by inspecting refrigerant lines for temperature changes. Remove restriction, evacuate, and recharge.
5. Replace, if defective.
6. Evacuate, replace element, recharge.
7. Trace and firm up connection.

Problem

Noisy operation.

Possible cause

1. Copper tubing vibrating
2. Machine vibrating out of level
3. Loose cabinet or internal component
4. Loose fan wheel
5. Blower wheel hitting shroud
6. Blower motor bearing defective
7. Blower bearing defectiv

Remedy

1. Adjust tubes by bending slightly to firm position without touching other unit parts.
2. Level unit base. Fully support base.
3. Check and tighten loose screws.
4. Tighten screws on fan wheel shaft.
5. Adjust wheel position on motor shaft
6. Replace fan motor.
7. Replace fan bearing.

Maintenance

maintenance procedures

⚠ WARNING

Hazardous voltage!

Disconnect all electric power, including remote disconnects before servicing. Follow proper lockout/tagout procedures to ensure the power can not be inadvertently energized. Failure to disconnect power before servicing could result in death or serious injury.

Problem

Insufficient cooling

Possible cause

1. Insufficient air flow due to: a) dirty evaporator; b) ice on evaporator coils (indicates airflow restriction through evaporator); c) dirty filter; d) obstructed discharge air intake; e) fan motor not running; f) evaporator fan or fan wheel slipping on motor shaft
2. Heat gain or loss in room exceeds unit capacity
3. Defective compressor
4. Insufficient refrigerant charge indicated by: a) low wattage; b) condenser air outlet cold
5. Overcharge of refrigerant indicated by high wattage and sweating of the compressor return line
6. Thermostat not set for full cooling
7. Insufficient airflow through condenser due to: a) dirty condenser; b) loose belt; c) fan loose on shaft
8. Cutout on high pressure
9. Only one refrigerant circuit operational in 2-circuit units

Remedy

1. Correct as follows: a) clean; b) defrost (using fan operation only); c) clean or replace filter; d) remove obstruction; e) check electrical system; f) adjust fan position. Tighten set screw on fan wheel.
2. Refer to original load calculations. Recalculate heat gain or loss.
3. Replace, if necessary.
4. Check refrigerant charge pressure with gauges. If refrigerant is low, recharge system.
5. Reclaim excess refrigerant.
6. Refer to thermostat operating instructions.
7. Correct as follows: a) clean coil; b) verify drive is adjusted correctly; c) tighten fan on shaft.
8. See that air is flowing and that damper is set properly.
9. Reset high pressure cutout on inoperative circuit. Check contactor in inoperative circuit.

Problem

Unit short cycles

Possible cause

1. Remote thermostat
2. Loose connection in electrical unit
3. Thermostat contacts fluttering
4. Air flow to evaporator is restricted
5. Insufficient charge

Remedy

1. Repair or replace.
2. Trace and repair.
3. Repair or replace.
4. Flush or blow dirt out of coil.
5. Reclaim, evacuate, recharge per nameplate.

Problem

Compressor starts and runs, but fan does not run.

Possible cause

1. Faulty switch
2. Open fan motor coil circuit
3. Fan binding on shroud or venturi ring

Remedy

1. Replace.
2. Replace.
3. Adjust fan mounting.



Trane
A business of American Standard Companies
www.trane.com

*For more information, contact your local Trane office
or e-mail us at comfort@trane.com*

Literature Order Number	SXIH-SVX01B-EN
Date	September 2007
Supersedes	SXIH-SVX01B-EN June 2007

Trane has a policy of continuous product and product data improvement and reserves the right to change design and specifications without notice.

Free Manuals Download Website

<http://myh66.com>

<http://usermanuals.us>

<http://www.somanuals.com>

<http://www.4manuals.cc>

<http://www.manual-lib.com>

<http://www.404manual.com>

<http://www.luxmanual.com>

<http://aubethermostatmanual.com>

Golf course search by state

<http://golfingnear.com>

Email search by domain

<http://emailbydomain.com>

Auto manuals search

<http://auto.somanuals.com>

TV manuals search

<http://tv.somanuals.com>