



TRANE®

Upflow/ Horizontal Left, Downflow/ Horizontal Right Variable Speed Two Stage Condensing Gas-Fired Furnace

XV 95

TUH2B060A9V3VA
TUH2B080A9V3VA
TUH2B080A9V4VA
TUH2C100A9V4VA
TUH2C100A9V5VA
TUH2D120A9V5VA

TDH2B060A9V3VA
TDH2B080A9V3VA
TDH2B080A9V4VA
TDH2C100A9V4VA
TDH2D120A9V5VA

Direct Vent with
Variable Speed Blower
Variable Speed Inducer

*UH-A9V-V

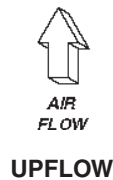
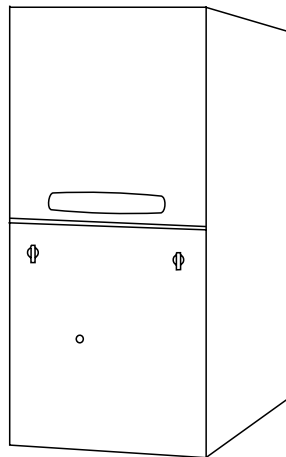

*DH-A9V-V

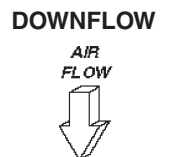
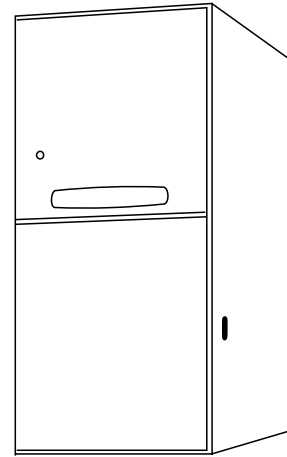

 AIR FLOW UPFLOW/HORIZONTAL

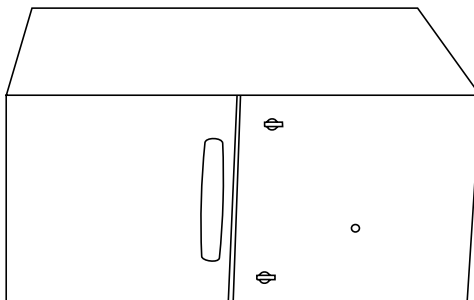

DOWNFLOW/HORIZONTAL AIR FLOW 

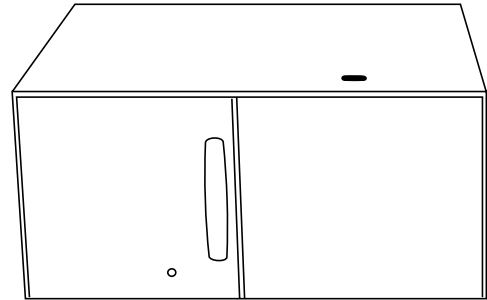

PUB. NO. 22-1814-08



General Features

NATURAL GAS MODELS

Central Heating furnace designs are certified by the American Gas Association for both natural and L.P. gas. Limit setting and rating data were established and approved under standard rating conditions using American National Standards Institute standards.

SAFE OPERATION

The Integrated System Control has solid state devices, which continuously monitor for presence of flame, when the system is in the heating mode of operation. Dual solenoid combination gas valve and regulator provide additional safety.

QUICK HEATING

Durable, cycle tested, heavy gauge **aluminized steel heat exchanger** quickly transfers heat to provide warm conditioned air to the structure. **Low energy power vent blower**, to increase efficiency and provide a positive discharge of gas fumes to the outside.

BURNERS

Multiport Inshot burners will give years of quiet and efficient service. All models can be converted to **L.P. gas** without changing burners.

INTEGRATED SYSTEM CONTROL

Exclusively designed operational program provides total control of furnace limit sensors, blowers, gas valve, flame control and includes self diagnostics for ease of service. Also contains connection points for E.A.C./Humidifier.

AIR DELIVERY

The variable speed blower motor has sufficient airflow for most heating and cooling requirements and will switch from heating to cooling speeds on demand from room thermostat. The blower door safety switch will prevent or terminate furnace operation when the blower door is removed.

SECONDARY HEAT EXCHANGER

The XV95 has a special type 29-4C™ stainless steel secondary heat exchanger to reclaim heat from flue gases which would normally be lost instead.

STYLING

Heavy gauge steel and “wrap-around” cabinet construction is used in the cabinet with baked-on enamel finish for strength and beauty. The heat exchanger section of the cabinet is completely lined with foil faced fiberglass insulation. This results in quiet and efficient operation due to the excellent acoustical and insulating qualities of fiberglass. Built-in bottom pan and alternate bottom, left or right side return air connection provision.

FEATURES AND GENERAL OPERATION

The XV95 High Efficiency Gas Furnaces utilize an Adaptive Heat Up Silicon Nitride Hot Surface Ignition system, which eliminates the waste of a constant burning pilot. The integrated system control lights the main burners upon a demand for heat from the room thermostat. Complete front service access.

- a. Low energy power venter
- b. Vent proving pressure switch.

Contents

General Features	2
Features and Benefits	4
Standard Equipment	4
Optional Equipment	5
General Data	6-8
TUH2B060A9V3VA	
TUH2B080A9V3VA	
TUH2B080A9V4VA	
TUH2C100A9V4VA	
TUH2C100A9V5VA	
TUH2D120A9V5VA	
TDH2B060A9V3VA	
TDH2B080A9V3VA	
TDH2B080A9V4VA	
TDH2C100A9V4VA	
TDH2D120A9V5VA	
Performance Data	9-19
Venting Table	20
Electrical Data	21-24
Field Wiring	25-26
Dimensions	27-28



Features and Benefits

XV 95 STANDARD EQUIPMENT

- Variable Speed Blower Motor
- Silicon Nitride Igniter with adaptive heat up
- Variable speed induced draft blower
- Direct/Non-Direct vent option
- Fused 24 volt control circuit
- Manual reset burner safety switches
- Power supply 115/1/60
- Convertible to horizontal on left side
- 2-stage gas valve
- PVC venting-1 or 2 pipe option
- Accessory hook-up capability
- Integrated solid state control with self-diagnostics
- Attractive color accents
- Heavy gauge aluminized steel heat exchanger
- Multi-port In-shot burners
- Quiet induced draft blower
- Lite Port™ extended system diagnostics
- Stored fault code history in micro processor nonvolatile memory
- Cleanable high velocity filters (upflow only)
- Hinged blower door *
- Perfect fit door latches*
- Insulated blower door*
- Gasketed blower door*
- Complete front service access
- Left/right gas connection
- Adjustable fan off times
- Optional L.P conversion kit
- Selectable cooling fan off delay eliminates need for BAY24X045 time delay kit

* (Upflow only)



Features and Benefits

XV 95 OPTIONAL EQUIPMENT

Thermostat, 2-Stage Heat / 1-Stage Cooling	TAYSTAT241 []
Thermostat, Media Programmable 2-Stage Heating	TAYSTAT302C []
Thermostat, Mechanical Heating Only With Fan Switch.....	TAYSTAT303C []
Thermostat, Heating/Cooling Single Stage (Mounts Horizontally)	AY28X092 []
Thermostat, Heating/Cooling Single Stage (Mounts Vertically)	BAYSTAT305 []
Thermostat, Media Programmable 1-Stage Heating/1-Stage Cooling	TAYSTAT300C []
Propane Conversion Kit.....	BAYLPKT210A []
Media Air Filter, "Perfect Fit" High Efficiency (14-1/2" Wide Gas Furnace).....	TFM145A9FR0 []
Media Air Filter, "Perfect Fit" High Efficiency (17-1/2" Wide Gas Furnace).....	TFM175A9FR0 []
Media Air Filter, "Perfect Fit" High Efficiency (21" Wide Gas Furnace).....	TFM210A9FR0 []
Media Air Filter, "Perfect Fit" High Efficiency (24-1/2" Wide Gas Furnace).....	TFM245A9FR0 []
Media Air Filter, "Perfect Fit" Standard Efficiency (14-1/2" Wide Gas Furnace)	TFP145A9FR0 []
Media Air Filter, "Perfect Fit" Standard Efficiency (17-1/2" Wide Gas Furnace)	TFP175A9FR0 []
Media Air Filter, "Perfect Fit" Standard Efficiency (21" Wide Gas Furnace).....	TFP210A9FR0 []
Media Air Filter, "Perfect Fit" Standard Efficiency (24-1/2" Wide Gas Furnace)	TFP245A9FR0 []
Coil Enclosure (14-1/2" Wide Cabinets)	BAYCLE14A1422A []
Coil Enclosure (17-1/2" Wide Cabinets)	BAYCLE17A1722A []
Coil Enclosure (21" Wide Cabinets)	BAYCLE21A2130A []
Coil Enclosure (24-1/2" Wide Cabinets)	BAYCLE24A2430A []
Downflow Subbase	BAYBASE205 []
Side Filter Rack	BAYFLTR200 []
Filter Kit/Horizontal Conversion TUH2-060,080.....	BAYFLTR203 []
Filter Kit/Horizontal Conversion TUH2-100.....	BAYFLTR204 []
Filter Kit/Horizontal Conversion TUH2-120.....	BAYFLTR205 []
High Altitude Pressure Switch Kit TUH2-060	BAYSWT10AHALTA① []
High Altitude Pressure Switch Kit TUH2-080,100,120	BAYSWT08AHALTA① []
Concentric Vent Kit TUH2 Furnaces.....	BAYAIR30AVENTA []
Sidewall Vent Termination Kit All 2 Pipe Direct Vent Furnaces	BAYVENT200B []
Manufactured/Mobile Home Kit All 2 Pipe Direct Vent Furnaces.....	BAYMFGH100A []
Cleanable Filter (14.5"/17.5" wide Upflow models).....	BAYFLTR317 []
Cleanable Filter (21" wide Upflow models).....	BAYFLTR321 []
Cleanable Filter (24.5" wide Upflow models).....	BAYFLTR324 []
CleanEffects™, Whole House Air Cleaner (Upflow 14-1/2" Wide Gas Furnace)	TFD145ALFR000B []
CleanEffects™, Whole House Air Cleaner (Upflow 17-1/2" Wide Gas Furnace)	TFD175ALFR000B []
CleanEffects™, Whole House Air Cleaner (Upflow 21" Wide Gas Furnace)	TFD210ALFR000B []
CleanEffects™, Whole House Air Cleaner (Upflow 24-1/2" Wide Gas Furnace)	TFD245ALFR000B []
CleanEffects™, Whole House Air Cleaner (Downflow 14-1/2" Wide Gas Furnace)	TFD14DALFR000B []
CleanEffects™, Whole House Air Cleaner (Downflow 17-1/2" Wide Gas Furnace)	TFD17DALFR000B []
CleanEffects™, Whole House Air Cleaner (Downflow 21" Wide Gas Furnace)	TFD21DALFR000B []
CleanEffects™, Whole House Air Cleaner (Downflow 24-1/2" Wide Gas Furnace)	TFD24DALFR000B []
CleanEffects™, Whole House Transformer Kit (120 to 24 Volt - all TFD Air Cleaners).....	BAYTRANS12024 []

① Optional kit allows 200 ft. max. vent length from 5,000-12,000 feet above sea level. See installer's guide.



General Data

TUH2 PRODUCT SPECIFICATIONS^①

Product Specifications^①

MODEL	TUH2B060A9V3VA	TUH2B080A9V3VA	TUH2B080A9V4VA	TUH2C100A9V4VA
TYPE	Upflow / Horizontal	Upflow / Horizontal	Upflow / Horizontal	Upflow / Horizontal
RATINGS^②				
1st Stage Input BTUH	39,000	52,000	52,000	65,000
1st Stage Capacity BTUH (ICS) ^③	37,830	50,440	50,440	62,855
2nd Stage Input BTUH	60,000	80,000	80,000	100,000
2nd Stage Capacity BTUH (ICS) ^③	58,200	77,600	77,600	96,700
AFUE	97	97	97	96.7
Temp. rise (Min.-Max.) °F.	35 - 65	35 - 65	35 - 65	35 - 65
BLOWER DRIVE				
Diameter - Width (In.)	DIRECT 10 x 8	DIRECT 10 x 8	DIRECT 11 x 8	DIRECT 10 x 10
No. Used	1	1	1	1
Speeds (No.)	Variable	Variable	Variable	Variable
CFM vs. in. w.g.	See Fan Performance Table	See Fan Performance Table	See Fan Performance Table	See Fan Performance Table
Motor HP	1/2	1/2	3/4	3/4
R.P.M.	Variable	Variable	Variable	Variable
Volts / Ph / Hz	115/1/60	115/1/60	115/1/60	115/1/60
COMBUSTION FAN - Type				
Drive - No. Speeds	Centrifugal Direct - Variable	Centrifugal Direct - Variable	Centrifugal Direct - Variable	Centrifugal Direct - Variable
Motor HP - RPM	1/50 - 5000	1/50 - 5000	1/50 - 5000	1/50 - 5000
Volts / Ph / Hz	33 - 110/3/60 - 180	33 - 110/3/60 - 180	33 - 110/3/60 - 180	33 - 110/3/60 - 180
FLA	1.0	1.0	1.0	1.0
FILTER — Furnished?				
Type Recommended	Yes	Yes	Yes	Yes
Hi Vel. (No.-Size-Thk.)	High Velocity 1 - 17x25 - 1 in.	High Velocity 1 - 17x25 - 1 in.	High Velocity 1 - 17x25 - 1 in.	High Velocity 1 - 20x25 - 1 in.
VENT — Size (in.)				
	2 Round	2 Round	2 Round	3 Round
HEAT EXCHANGER				
Type - Fired	Aluminized Steel - Type I	Aluminized Steel - Type I	Aluminized Steel - Type I	Aluminized Steel - Type I
-Unfired				
Gauge (Fired)	20	20	20	20
ORIFICES — Main				
Nat. Gas Qty. — Drill Size	3 — 45	4 — 45	4 — 45	5 — 45
L.P. Gas Qty. — Drill Size	3 — 56	4 — 56	4 — 56	5 — 56
GAS VALVE				
	Redundant - Two Stage	Redundant - Two Stage	Redundant - Two Stage	Redundant - Two Stage
PILOT SAFETY DEVICE				
Type	Hot Surface Igniter	Hot Surface Igniter	Hot Surface Igniter	Hot Surface Igniter
BURNERS — Type				
Number	Multiport Inshot 3	Multiport Inshot 4	Multiport Inshot 4	Multiport Inshot 5
POWER CONN. — V/Ph/Hz^④				
Ampacity (In Amps)	115/1/60 11.1	115/1/60 11.1	115/1/60 13.5	115/1/60 13.5
Max. Overcurrent Protection (Amps)	15	15	20	20
PIPE CONN. SIZE (IN.)				
	1/2	1/2	1/2	1/2
DIMENSIONS				
Crated (In.)	H x W x D 41-3/4 x 19-1/2 x 30-1/2	H x W x D 41-3/4 x 19-1/2 x 30-1/2	H x W x D 41-3/4 x 19-1/2 x 30-1/2	H x W x D 41-3/4 x 23 x 30-1/2
WEIGHT				
Shipping (Lbs.)/Net (Lbs)	158 / 146	168 / 156	170 / 158	197 / 185

① Central Furnace heating designs are certified to ANSI Z21.47 / CSA 2.3

② For U.S. applications, above input ratings (BTUH) are up to 2,000 feet, derate 4% per 1,000 feet for elevations above 2,000 feet above sea level. For Canadian applicaitons, above input ratings (BTUH) are up to 4,500 feet, derate 4% per 1,000 feet for elevations above 4,500 feet above sea level.

③ Based on U.S. government standard tests.

④ The above wiring specifications are in accordance with National Electrical Code; however, installations must comply with local codes.



General Data

TUH2/TDH2 PRODUCT SPECIFICATIONS^①

PRODUCT SPECIFICATIONS^①

MODEL	TUH2C100A9V5VA	TUH2D120A9V5VA	TDH2B060A9V3VA	TDH2B080A9V3VA
TYPE	Upflow / Horizontal	Upflow / Horizontal	Downflow / Horizontal	Downflow / Horizontal
RATINGS ^②				
1st Stage Input BTUH	65,000	78,000	39,000	52,000
1st Stage Capacity BTUH (ICS) ^③	62,855	75,426	37,000	49,400
2nd Stage Input BTUH	100,000	120,000	60,000	80,000
2nd Stage Capacity BTUH (ICS) ^③	96,700	116,040	57,000	76,000
AFUE	96.7	96.7	95	95
Temp. rise (Min.-Max.) °F.	35 - 65	40 - 70	35 - 65	35 - 65
BLOWER DRIVE				
Diameter - Width (In.)	DIRECT 11 x 10	DIRECT 10 x 10	DIRECT 10 x 8	DIRECT 10 x 8
No. Used	1	1	1	1
Speeds (No.)	Variable	Variable	Variable	Variable
CFM vs. in. w.g.	See Fan Performance Table	See Fan Performance Table	See Fan Performance Table	See Fan Performance Table
Motor HP	1	1	1/2	1/2
R.P.M.	Variable	Variable	Variable	Variable
Volts / Ph / Hz	115/1/60	115/1/60	115/1/60	115/1/60
COMBUSTION FAN - Type				
Drive - No. Speeds	Centrifugal Direct - Variable	Centrifugal Direct - Variable	Centrifugal Direct - Variable	Centrifugal Direct - Variable
Motor HP - RPM	1/50 - 5000	1/50 - 5000	1/50 - 5000	1/50 - 5000
Volts / Ph / Hz	33 - 110/3/60 - 180	33 - 110/3/60 - 180	33 - 110/3/60 - 180	33 - 110/3/60 - 180
FLA	1.0	1.0	1.0	1.0
FILTER — Furnished?				
Type Recommended	Yes	Yes	Yes	Yes
Hi Vel. (No.-Size-Thk.)	High Velocity 1 - 20x25 - 1 in.	High Velocity 1 - 24x25 - 1 in.	High Velocity 2 - 14x20 - 1 in.	High Velocity 2 - 14x20 - 1 in.
VENT — Size (in.)				
	3 Round	3 Round	2 Round	2 Round
HEAT EXCHANGER				
Type - Fired	Aluminized Steel - Type I	Aluminized Steel - Type I	Aluminized Steel - Type I	Aluminized Steel - Type I
-Unfired				
Gauge (Fired)	20	20	20	20
ORIFICES — Main				
Nat. Gas Qty. — Drill Size	5 — 45	6 — 45	3 — 45	4 — 45
L.P. Gas Qty. — Drill Size	5 — 56	6 — 56	3 — 56	4 — 56
GAS VALVE				
	Redundant - Two Stage	Redundant - Two Stage	Redundant - Two Stage	Redundant - Two Stage
PILOT SAFETY DEVICE				
Type	Hot Surface Igniter	Hot Surface Igniter	Hot Surface Igniter	Hot Surface Igniter
BURNERS — Type				
Number	Multiport Inshot 5	Multiport Inshot 6	Multiport Inshot 3	Multiport Inshot 4
POWER CONN. — V / Ph / Hz ^④				
Ampacity (In Amps)	115/1/60 16.3	115/1/60 15.2	115/1/60 11.1	115/1/60 11.1
Max. Overcurrent Protection (Amps)	20	20	15	15
PIPE CONN. SIZE (IN.)				
	1/2	1/2	1/2	1/2
DIMENSIONS				
Crated (In.)	H x W x D 41-3/4 x 23 x 30-1/2	H x W x D 41-3/4 x 26-1/2 x 30-1/2	H x W x D 41-3/4 x 19-1/2 x 30-1/2	H x W x D 41-3/4 x 19-1/2 x 30-1/2
WEIGHT				
Shipping (Lbs.) / Net (Lbs)	199 / 187	206 / 193	160 / 146	168 / 158

① Central Furnace heating designs are certified to ANSI Z21.47 / CSA 2.3

② For U.S. applications, above input ratings (BTUH) are up to 2,000 feet, derate 4% per 1,000 feet for elevations above 2,000 feet above sea level. For Canadian applicaitons, above input ratings (BTUH) are up to 4,500 feet, derate 4% per 1,000 feet for elevations above 4,500 feet above sea level.

③ Based on U.S. government standard tests.

④ The above wiring specifications are in accordance with National Electrical Code; however, installations must comply with local codes.



General Data

TDH2 PRODUCT SPECIFICATIONS^①

PRODUCT SPECIFICATIONS^①

MODEL	TDH2B080A9V4VA	TDH2C100A9V4VA	TDH2D120A9V5VA
TYPE	Downflow / Horizontal	Downflow / Horizontal	Downflow / Horizontal
RATINGS^②			
1st Stage Input BTUH	52,000	65,000	78,000
1st Stage Capacity BTUH (ICS) ^③	49,400	61,750	74,000
2nd Stage Input BTUH	80,000	100,000	120,000
2nd Stage Capacity BTUH (ICS) ^③	76,000	95,000	114,000
AFUE	95	95	95
Temp. rise (Min.-Max.) °F.	35 - 65	35 - 65	40 - 70
BLOWER DRIVE			
Drive	DIRECT	DIRECT	DIRECT
Diameter - Width (In.)	11 x 8	10 x 10	10 x 10
No. Used	1	1	1
Speeds (No.)	Variable	Variable	Variable
CFM vs. in. w.g.	See Fan Performance Table	See Fan Performance Table	See Fan Performance Table
Motor HP	3/4	3/4	1
R.P.M.	Variable	Variable	Variable
Volts/Ph/Hz	115/1/60	115/1/60	115/1/60
COMBUSTION FAN - Type			
Drive - No. Speeds	Centrifugal	Centrifugal	Centrifugal
Motor HP - RPM	Direct - Variable	Direct - Variable	Direct - Variable
Volts/Ph/Hz	1/50 - 5000	1/50 - 5000	1/50 - 5000
FLA	33 - 110/3/60 - 180	33 - 110/3/60 - 180	33 - 110/3/60 - 180
	1.0	1.0	1.0
FILTER — Furnished?			
Type Recommended	Yes	Yes	Yes
Hi Vel. (No.-Size-Thk.)	High Velocity	High Velocity	High Velocity
	2 - 14x20 - 1 in.	2 - 16x20 - 1 in.	2 - 16x20 - 1 in.
VENT — Size (in.)			
	2 Round	3 Round	3 Round
HEAT EXCHANGER			
Type - Fired	Aluminized Steel - Type I	Aluminized Steel - Type I	Aluminized Steel - Type I
-Unfired			
Gauge (Fired)	20	20	20
ORIFICES — Main			
Nat. Gas Qty. — Drill Size	4 — 45	5 — 45	6 — 45
L.P. Gas Qty. — Drill Size	4 — 56	5 — 56	6 — 56
GAS VALVE			
	Redundant - Two Stage	Redundant - Two Stage	Redundant - Two Stage
PILOT SAFETY DEVICE			
Type	Hot Surface Igniter	Hot Surface Igniter	Hot Surface Igniter
BURNERS — Type			
Number	Multiport Inshot	Multiport Inshot	Multiport Inshot
	4	5	6
POWER CONN. — V/Ph/Hz^④			
Ampacity (In Amps)	115/1/60	115/1/60	115/1/60
Max. Overcurrent Protection (Amps)	13.5	13.5	15.2
	20	20	20
PIPE CONN. SIZE (IN.)			
	1/2	1/2	1/2
DIMENSIONS			
Crated (In.)	H x W x D	H x W x D	H x W x D
	41-3/4 x 19-1/2 x 30-1/2	41-3/4 x 23 x 30-1/2	41-3/4 x 26-1/2 x 30-1/2
WEIGHT			
Shipping (Lbs.)/Net (Lbs)	172 / 160	185 / 175	206 / 196

*UH2B060A9V3V FURNACE HEATING AIRFLOW (CFM) AND POWER (WATTS) VS. EXTERNAL STATIC PRESSURE WITH FILTER									
1st Stage Capacity = 37,830 2nd Stage Capacity = 58,200									
	AIRFLOW SETTING	DIP SWITCH SETTING			EXTERNAL STATIC PRESSURE				
		SW 7	SW 8		0.1	0.3	0.5	0.7	0.9
HEATING 1ST STAGE	LOW	ON	ON	CFM TEMP. RISE WATTS	600 57 85	600 57 110	600 57 155	600 57 190	-
	MEDIUM LOW	OFF	ON	CFM TEMP. RISE WATTS	700 49 90	700 49 130	700 49 175	700 49 210	-
	NORMAL **	ON	OFF	CFM TEMP. RISE WATTS	775 44 105	775 44 155	775 44 195	775 44 240	-
	HIGH	OFF	OFF	CFM TEMP. RISE WATTS	870 39 135	870 39 185	870 39 235	870 39 290	-
HEATING 2ND STAGE	LOW	ON	ON	CFM TEMP. RISE WATTS	860 61 140	920 57 200	920 57 245	920 57 300	670 79 245
	MEDIUM LOW	OFF	ON	CFM TEMP. RISE WATTS	1000 53 190	1000 53 255	1000 53 305	1000 53 340	700 75 255
	NORMAL **	ON	OFF	CFM TEMP. RISE WATTS	1125 47 250	1125 47 315	1125 47 370	1025 51 355	775 68 285
	HIGH	OFF	OFF	CFM TEMP. RISE WATTS	1250 42 340	1250 42 405	1250 42 445	1100 48 390	1000 53 355

NOTES: * First letter may be "A" or "T"
** Factory setting

*UH2B060A9V3V FURNACE COOLING AIRFLOW (CFM) AND POWER (WATTS) VS. EXTERNAL STATIC PRESSURE WITH FILTER											
OUTDOOR UNIT SIZE (TONS)	AIRFLOW SETTING	DIP SWITCH SETTING					EXTERNAL STATIC PRESSURE				
		SW 1	SW 2	SW 3	SW 4		0.1	0.3	0.5	0.7	0.9
1.5	LOW (350 CFM/TON)	ON	ON	OFF	ON	CFM WATTS	575 65	575 90	575 125	550 155	-
	NORMAL (400 CFM/TON)	ON	ON	OFF	OFF	CFM WATTS	640 70	640 110	640 140	630 175	-
	HIGH (450 CFM/TON)	ON	ON	ON	OFF	CFM WATTS	700 85	700 125	700 160	700 200	-
2.0	LOW (350 CFM/TON)	OFF	ON	OFF	ON	CFM WATTS	700 100	700 130	700 170	700 210	-
	NORMAL (400 CFM/TON)	OFF	ON	OFF	OFF	CFM WATTS	800 115	800 155	800 200	800 250	-
	HIGH (450 CFM/TON)	OFF	ON	ON	OFF	CFM WATTS	900 140	900 195	900 240	900 290	-
2.5	LOW (350 CFM/TON)	ON	OFF	OFF	ON	CFM WATTS	875 130	875 180	875 230	875 270	-
	NORMAL (400 CFM/TON)	ON	OFF	OFF	OFF	CFM WATTS	1000 175	1000 235	1000 285	1000 335	900 310
	HIGH (450 CFM/TON)	ON	OFF	ON	OFF	CFM WATTS	1125 235	1125 295	1125 345	1100 370	925 318
3	LOW (350 CFM/TON)	OFF	OFF	OFF	ON	CFM WATTS	1050 195	1050 260	1050 305	1050 350	920 315
	NORMAL (400 CFM/TON)	OFF	OFF	OFF	OFF	CFM WATTS	1200 275	1200 330	1200 385	1100 385	940 330
	HIGH (450 CFM/TON)	OFF	OFF	ON	OFF	CFM WATTS	1325 360	1325 425	1300 460	1175 425	1000 365

NOTES: * First letter may be "A" or "T"
1. At continuous fan setting: Heating or Cooling airflows are approximately 50% of selected cooling value.
2. LOW airflow (350 cfm/ton) is COMFORT & HUMID CLIMATE setting;
NORMAL airflow (400 cfm/ton) is typical setting;
HIGH airflow (450 cfm/ton) is DRY CLIMATE setting.

*UH2B080A9V3V FURNACE HEATING AIRFLOW (CFM) AND POWER (WATTS) VS. EXTERNAL STATIC PRESSURE WITH FILTER									
					1st Stage Capacity = 50,440 2nd Stage Capacity = 77,600				
	AIRFLOW SETTING	DIP SWITCH SETTING			EXTERNAL STATIC PRESSURE				
		SW 7	SW 8		0.1	0.3	0.5	0.7	0.9
HEATING 1ST STAGE	LOW	ON	ON	CFM	800	800	800	800	800
				TEMP. RISE	56	56	56	56	56
				WATTS	105	140	180	220	265
	MEDIUM LOW	OFF	ON	CFM	860	880	890	920	910
				TEMP. RISE	52	51	50	48	49
				WATTS	115	165	215	265	320
HEATING 2ND STAGE	NORMAL **	ON	OFF	CFM	960	990	1000	1020	1010
				TEMP. RISE	46	45	44	44	44
				WATTS	150	200	230	310	350
	HIGH	OFF	OFF	CFM	1080	1110	1120	1120	1080
				TEMP. RISE	41	40	40	40	41
				WATTS	195	255	315	365	390
HEATING 2ND STAGE	LOW	ON	ON	CFM	1100	1100	1120	1120	1090
				TEMP. RISE	62	62	61	61	63
				WATTS	205	260	320	370	400
	MEDIUM LOW	OFF	ON	CFM	1210	1240	1260	1260	1130
				TEMP. RISE	57	55	54	54	61
				WATTS	265	340	410	470	430
HEATING 2ND STAGE	NORMAL **	ON	OFF	CFM	1360	1390	1400	1360	1210
				TEMP. RISE	50	49	49	50	57
				WATTS	365	445	500	535	475
	HIGH	OFF	OFF	CFM	1360	1390	1400	1350	1180
				TEMP. RISE	50	49	49	51	58
				WATTS	355	450	520	535	465

NOTES: * First letter may be "A" or "T"
** Factory setting

*UH2B080A9V3V FURNACE COOLING AIRFLOW (CFM) AND POWER (WATTS) VS. EXTERNAL STATIC PRESSURE WITH FILTER											
OUTDOOR UNIT SIZE (TONS)	AIRFLOW SETTING	DIP SWITCH SETTING					EXTERNAL STATIC PRESSURE				
		SW 1	SW 2	SW 3	SW 4		0.1	0.3	0.5	0.7	0.9
2.0	LOW (350 CFM/TON)	ON	ON	OFF	ON	CFM WATTS	750 84	750 122	750 154	720 185	710 221
	NORMAL (400 CFM/TON)	ON	ON	OFF	OFF	CFM WATTS	840 109	840 146	840 181	840 226	820 264
	HIGH (450 CFM/TON)	ON	ON	ON	OFF	CFM WATTS	940 136	940 177	940 215	940 274	940 318
2.5	LOW (350 CFM/TON)	OFF	ON	OFF	ON	CFM WATTS	850 113	850 150	870 200	890 250	890 295
	NORMAL (400 CFM/TON)	OFF	ON	OFF	OFF	CFM WATTS	960 150	990 200	1000 230	1020 305	1010 350
	HIGH (450 CFM/TON)	OFF	ON	ON	OFF	CFM WATTS	1080 195	1110 255	1120 315	1120 365	1080 390
3.0	LOW (350 CFM/TON)	ON	OFF	OFF	ON	CFM WATTS	1020 175	1020 225	1040 280	1050 330	1050 375
	NORMAL (400 CFM/TON)	ON	OFF	OFF	OFF	CFM WATTS	1170 240	1180 300	1200 365	1200 415	1130 420
	HIGH (450 CFM/TON)	ON	OFF	ON	OFF	CFM WATTS	1290 310	1320 410	1350 470	1340 520	1150 440
3.5	LOW (350 CFM/TON)	OFF	OFF	OFF	ON	CFM WATTS	1170 250	1190 315	1210 370	1210 435	1100 405
	NORMAL (400 CFM/TON)	OFF	OFF	OFF	OFF	CFM WATTS	1360 365	1390 445	1400 500	1360 535	1210 475
	HIGH (450 CFM/TON)	OFF	OFF	ON	OFF	CFM WATTS	1360 355	1390 450	1400 520	1350 535	1180 460

NOTES: * First letter may be "A" or "T"
1. At continuous fan setting: Heating or Cooling airflows are approximately 50% of selected cooling value.
2. LOW airflow (350 cfm/ton) is COMFORT & HUMID CLIMATE setting;
NORMAL airflow (400 cfm/ton) is typical setting;
HIGH airflow (450 cfm/ton) is DRY CLIMATE setting.

*UH2B080A9V4V FURNACE HEATING AIRFLOW (CFM) AND POWER (WATTS) VS. EXTERNAL STATIC PRESSURE WITH FILTER									
1st Stage Capacity = 50,440 2nd Stage Capacity = 77,600									
	AIRFLOW SETTING	DIP SWITCH SETTING			EXTERNAL STATIC PRESSURE				
		SW 7	SW 8		0.1	0.3	0.5	0.7	0.9
HEATING 1ST STAGE	LOW	ON	ON	CFM	800	800	800	800	800
				TEMP. RISE	56	56	56	56	56
				WATTS	105	140	180	220	265
	MEDIUM LOW	OFF	ON	CFM	860	880	890	920	910
TEMP. RISE				52	51	50	48	49	
WATTS				115	165	215	265	320	
NORMAL **	ON	OFF	CFM	960	990	1000	1020	1010	
			TEMP. RISE	46	45	44	44	44	
			WATTS	150	200	230	310	350	
HIGH	OFF	OFF	CFM	1080	1110	1120	1120	1080	
			TEMP. RISE	41	40	40	40	41	
			WATTS	195	255	315	365	390	
HEATING 2ND STAGE	LOW	ON	ON	CFM	1100	1100	1120	1120	1090
				TEMP. RISE	62	62	61	61	63
				WATTS	205	260	320	370	400
	MEDIUM LOW	OFF	ON	CFM	1210	1240	1260	1260	1130
TEMP. RISE				57	55	54	54	61	
WATTS				265	340	410	470	430	
NORMAL **	ON	OFF	CFM	1360	1390	1400	1360	1210	
			TEMP. RISE	50	49	49	50	57	
			WATTS	365	445	500	535	475	
HIGH	OFF	OFF	CFM	1360	1390	1400	1350	1180	
			TEMP. RISE	50	49	49	51	58	
			WATTS	355	450	520	535	465	

NOTES: * First letter may be "A" or "T"
** Factory setting

*UH2B080A9V4V FURNACE COOLING AIRFLOW (CFM) AND POWER (WATTS) VS. EXTERNAL STATIC PRESSURE WITH FILTER											
OUTDOOR UNIT SIZE (TONS)	AIRFLOW SETTING	DIP SWITCH SETTING					EXTERNAL STATIC PRESSURE				
		SW 1	SW 2	SW 3	SW 4		0.1	0.3	0.5	0.7	0.9
2.5	LOW (350 CFM/TON)	ON	ON	OFF	ON	CFM WATTS	857 107	849 143	841 179	833 223	825 266
	NORMAL (400 CFM/TON)	ON	ON	OFF	OFF	CFM WATTS	970 158	971 205	973 251	966 298	960 345
	HIGH (450 CFM/TON)	ON	ON	ON	OFF	CFM WATTS	1082 209	1093 266	1104 323	1099 374	1095 424
3.0	LOW (350 CFM/TON)	OFF	ON	OFF	ON	CFM WATTS	1004 153	1019 210	1035 267	1038 321	1041 374
	NORMAL (400 CFM/TON)	OFF	ON	OFF	OFF	CFM WATTS	1163 249	1173 311	1184 372	1179 426	1174 480
	HIGH (450 CFM/TON)	OFF	ON	ON	OFF	CFM WATTS	1323 345	1328 411	1332 477	1320 532	1307 586
3.5	LOW (350 CFM/TON)	ON	OFF	OFF	ON	CFM WATTS	1176 254	1188 317	1200 380	1195 437	1190 494
	NORMAL (400 CFM/TON)	ON	OFF	OFF	OFF	CFM WATTS	1356 379	1362 446	1368 514	1353 568	1339 623
	HIGH (450 CFM/TON)	ON	OFF	ON	OFF	CFM WATTS	1536 503	1536 575	1536 647	1512 699	1488 751
4.0	LOW (350 CFM/TON)	OFF	OFF	OFF	ON	CFM WATTS	1376 374	1367 429	1359 483	1354 547	1348 611
	NORMAL (400 CFM/TON)	OFF	OFF	OFF	OFF	CFM WATTS	1562 530	1562 604	1563 677	1531 720	1499 765
	HIGH (450 CFM/TON)	OFF	OFF	ON	OFF	CFM WATTS	1768 757	1759 830	1749 902	1654 866	1559 829

NOTES: * First letter may be "A" or "T"
1. At continuous fan setting: Heating or Cooling airflows are approximately 50% of selected cooling value.
2. LOW airflow (350 cfm/ton) is COMFORT & HUMID CLIMATE setting;
NORMAL airflow (400 cfm/ton) is typical setting;
HIGH airflow (450 cfm/ton) is DRY CLIMATE setting.

*UH2C100A9V4V FURNACE HEATING AIRFLOW (CFM) AND POWER (WATTS) VS. EXTERNAL STATIC PRESSURE WITH FILTER									
					1st Stage Capacity = 62,855 2nd Stage Capacity = 96,700				
	AIRFLOW SETTING	DIP SWITCH SETTING			EXTERNAL STATIC PRESSURE				
		SW 7	SW8		0.1	0.3	0.5	0.7	0.9
HEATING 1ST STAGE	LOW	ON	ON	CFM	873	893	900	899	902
				TEMP. RISE	64	63	62	62	62
				WATTS	100	145	195	240	290
	MEDIUM LOW	OFF	ON	CFM	971	997	1006	1022	1029
TEMP. RISE				58	56	56	55	54	
WATTS				115	170	220	280	335	
MEDIUM **	ON	OFF	CFM	1136	1146	1165	1180	1184	
			TEMP. RISE	49	49	48	47	47	
			WATTS	160	230	295	365	425	
HIGH	OFF	OFF	CFM	1258	1298	1319	1328	1286	
			TEMP. RISE	44	43	42	42	44	
			WATTS	225	300	390	450	490	
HEATING 2ND STAGE	LOW	ON	ON	CFM	1260	1304	1329	1334	1317
				TEMP. RISE	68	66	65	65	65
				WATTS	213	305	380	460	510
	MEDIUM LOW	OFF	ON	CFM	1464	1471	1478	1478	1350
TEMP. RISE				59	59	58	58	64	
WATTS				315	405	485	560	540	
MEDIUM **	ON	OFF	CFM	1631	1678	1690	1579	1419	
			TEMP. RISE	53	51	51	55	61	
			WATTS	450	570	670	645	585	
HIGH	OFF	OFF	CFM	1846	1867	1794	1644	1498	
			TEMP. RISE	47	46	48	52	57	
			WATTS	640	760	770	700	650	

NOTES: * First letter may be "A" or "T"
** Factory setting

*UH2C100A9V4V FURNACE COOLING AIRFLOW (CFM) AND POWER (WATTS) VS. EXTERNAL STATIC PRESSURE WITH FILTER											
OUTDOOR UNIT SIZE (TONS)	AIRFLOW SETTING	DIP SWITCH SETTING					EXTERNAL STATIC PRESSURE				
		SW 1	SW 2	SW 3	SW 4		0.1	0.3	0.5	0.7	0.9
2.5	LOW (350 CFM/TON)	ON	ON	OFF	ON	CFM WATTS	808 75	824 125	840 170	835 210	830 250
	NORMAL (400 CFM/TON)	ON	ON	OFF	OFF	CFM WATTS	938 100	963 160	959 205	964 255	975 310
	HIGH (450 CFM/TON)	ON	ON	ON	OFF	CFM WATTS	1058 150	1100 200	1121 265	1136 330	1142 395
3.0	LOW (350 CFM/TON)	OFF	ON	OFF	ON	CFM WATTS	1004 120	1010 175	1027 230	1044 285	1050 345
	NORMAL (400 CFM/TON)	OFF	ON	OFF	OFF	CFM WATTS	1141 170	1190 245	1214 310	1229 380	1234 450
	HIGH (450 CFM/TON)	OFF	ON	ON	OFF	CFM WATTS	1336 250	1375 330	1387 410	1388 480	1384 545
3.5	LOW (350 CFM/TON)	ON	OFF	OFF	ON	CFM WATTS	1153 180	1206 250	1230 320	1239 395	1244 460
	NORMAL (400 CFM/TON)	ON	OFF	OFF	OFF	CFM WATTS	1390 285	1418 465	1439 445	1441 515	1373 540
	HIGH (450 CFM/TON)	ON	OFF	ON	OFF	CFM WATTS	1575 400	1606 495	1632 590	1596 645	1445 590
4.0	LOW (350 CFM/TON)	OFF	OFF	OFF	ON	CFM WATTS	1388 290	1423 360	1444 440	1444 515	1390 540
	NORMAL (400 CFM/TON)	OFF	OFF	OFF	OFF	CFM WATTS	1610 415	1641 515	1666 635	1607 650	1449 595
	HIGH (450 CFM/TON)	OFF	OFF	ON	OFF	CFM WATTS	1847 630	1863 735	1816 780	1687 720	1532 665

NOTES: *First letter may be "A" or "T"
1. At Continuous fan setting: Heating or Cooling airflows are approximately 50% of selected cooling value.
2. LOW airflow (350 cfm/ton) is COMFORT & HUMID CLIMATE setting;
NORMAL airflow (400 cfm/ton) is typical setting;
HIGH airflow (450 cfm/ton) is DRY CLIMATE setting.

*UH2C100A9V5V FURNACE HEATING AIRFLOW (CFM) AND POWER (WATTS) VS. EXTERNAL STATIC PRESSURE WITH FILTER									
1st Stage Capacity = 62,855 2nd Stage Capacity = 96,700									
	AIRFLOW SETTING	DIP SWITCH SETTING			EXTERNAL STATIC PRESSURE				
		SW 7	SW 8		0.1	0.3	0.5	0.7	0.9
HEATING 1ST STAGE	LOW	ON	ON	CFM TEMP. RISE WATTS	873 64 100	893 63 145	900 62 195	899 62 240	902 62 290
	MEDIUM LOW	OFF	ON	CFM TEMP. RISE WATTS	971 58 115	997 56 170	1006 56 220	1022 55 280	1029 54 335
	MEDIUM **	ON	OFF	CFM TEMP. RISE WATTS	1136 49 160	1146 49 230	1165 48 295	1180 47 365	1184 47 425
	HIGH	OFF	OFF	CFM TEMP. RISE WATTS	1258 44 225	1298 43 300	1319 42 390	1328 42 450	1286 44 490
HEATING 2ND STAGE	LOW	ON	ON	CFM TEMP. RISE WATTS	1260 68 213	1304 66 305	1329 65 380	1334 65 460	1317 65 510
	MEDIUM LOW	OFF	ON	CFM TEMP. RISE WATTS	1464 59 315	1471 59 405	1478 58 485	1478 58 560	1350 64 540
	MEDIUM **	ON	OFF	CFM TEMP. RISE WATTS	1631 53 450	1678 51 570	1690 51 670	1579 55 645	1419 61 585
	HIGH	OFF	OFF	CFM TEMP. RISE WATTS	1846 47 640	1867 46 760	1794 48 770	1644 52 700	1498 57 650

NOTES:
 * First letter may be "A" or "T"
 ** Factory setting

*UH2C100A9V5V FURNACE COOLING AIRFLOW (CFM) AND POWER (WATTS) VS. EXTERNAL STATIC PRESSURE WITH FILTER											
OUTDOOR UNIT SIZE (TONS)	AIRFLOW SETTING	DIP SWITCH SETTING					EXTERNAL STATIC PRESSURE				
		SW 1	SW 2	SW 3	SW 4		0.1	0.3	0.5	0.7	0.9
3.5	LOW (350 CFM/TON)	OFF	ON	OFF	ON	CFM WATTS	1163 222	1201 304	1209 375	1200 433	1199 495
	NORMAL (400 CFM/TON)	OFF	ON	OFF	OFF	CFM WATTS	1339 331	1365 400	1366 477	1377 555	1382 636
	HIGH (450 CFM/TON)	OFF	ON	ON	OFF	CFM WATTS	1515 440	1538 535	1549 620	1553 708	1547 796
4.0	LOW (350 CFM/TON)	ON	OFF	OFF	ON	CFM WATTS	1339 331	1365 400	1366 477	1377 555	1382 636
	NORMAL (400 CFM/TON)	ON	OFF	OFF	OFF	CFM WATTS	1550 471	1562 550	1574 645	1575 733	1564 813
	HIGH (450 CFM/TON)	ON	OFF	ON	OFF	CFM WATTS	1744 626	1758 736	1770 838	1772 935	1760 1018
5.0	LOW (350 CFM/TON)	OFF	OFF	OFF	ON	CFM WATTS	1695 578	1709 728	1721 820	1772 930	1711 1007
	NORMAL (400 CFM/TON)	OFF	OFF	OFF	OFF	CFM WATTS	1919 862	1919 958	1905 1043	1831 1043	1709 982
	HIGH (450 CFM/TON)	OFF	OFF	ON	OFF	CFM WATTS	NA NA	NA NA	NA NA	NA NA	NA NA

NOTES: *First letter may be "A" or "T"
 1. At Continuous fan setting: Heating or Cooling airflows are approximately 50% of selected cooling value.
 2. LOW airflow (350 cfm/ton) is COMFORT & HUMID CLIMATE setting;
 NORMAL airflow (400 cfm/ton) is typical setting;
 HIGH airflow (450 cfm/ton) is DRY CLIMATE setting.
 3. NA = Not allowed.

*UH2D120A9V5V FURNACE HEATING AIRFLOW (CFM) AND POWER (WATTS) VS. EXTERNAL STATIC PRESSURE WITH FILTER									
1st Stage Capacity = 75,426 2nd Stage Capacity = 116,040									
	AIRFLOW SETTING	DIP SWITCH SETTING			EXTERNAL STATIC PRESSURE				
		SW 7	SW 8		0.1	0.3	0.5	0.7	0.9
HEATING 1ST STAGE	LOW	ON	ON	CFM TEMP. RISE WATTS	1090 62 165	1120 60 225	1080 63 270	1070 63 310	1010 67 380
	MEDIUM LOW	OFF	ON	CFM TEMP. RISE WATTS	1210 56 220	1200 56 280	1200 56 330	1180 57 395	1160 58 455
	NORMAL **	ON	OFF	CFM TEMP. RISE WATTS	1340 50 295	1360 50 350	1370 49 425	1380 49 495	1330 51 535
	HIGH	OFF	OFF	CFM TEMP. RISE WATTS	1430 47 390	1570 43 490	1580 43 565	1570 43 625	1390 49 565
HEATING 2ND STAGE	LOW	ON	ON	CFM TEMP. RISE WATTS	1660 63 485	1690 62 590	1680 62 640	1640 64 675	1460 72 600
	MEDIUM LOW	OFF	ON	CFM TEMP. RISE WATTS	1870 56 675	1870 56 745	1810 58 770	1680 62 715	1490 70 625
	NORMAL **	ON	OFF	CFM TEMP. RISE WATTS	2060 51 880	1990 53 890	1850 57 810	1710 61 750	1530 68 665
	HIGH	OFF	OFF	CFM TEMP. RISE WATTS	2200 48 1030	2090 50 965	1940 54 895	1790 58 830	1640 64 750

NOTES:
 * First letter may be "A" or "T"
 ** Factory setting

*UH2D120A9V5V FURNACE COOLING AIRFLOW (CFM) AND POWER (WATTS) VS. EXTERNAL STATIC PRESSURE WITH FILTER											
OUTDOOR UNIT SIZE (TONS)	AIRFLOW SETTING	DIP SWITCH SETTING					EXTERNAL STATIC PRESSURE				
		SW 1	SW 2	SW 3	SW 4		0.1	0.3	0.5	0.7	0.9
3.5	LOW (350 CFM/TON)	OFF	ON	OFF	ON	CFM WATTS	1210 220	1210 270	1220 325	1230 400	1230 445
	NORMAL (400 CFM/TON)	OFF	ON	OFF	OFF	CFM WATTS	1400 305	1440 390	1450 465	1450 510	1410 560
	HIGH (450 CFM/TON)	OFF	ON	ON	OFF	CFM WATTS	1590 425	1600 520	1610 600	1600 645	1380 575
4.0	LOW (350 CFM/TON)	ON	OFF	OFF	ON	CFM WATTS	1390 305	1400 375	1430 445	1440 515	1420 565
	NORMAL (400 CFM/TON)	ON	OFF	OFF	OFF	CFM WATTS	1620 420	1650 530	1670 595	1640 660	1480 600
	HIGH (450 CFM/TON)	ON	OFF	ON	OFF	CFM WATTS	1840 600	1830 690	1820 765	1670 700	1490 620
5	LOW (350 CFM/TON)	OFF	OFF	OFF	ON	CFM WATTS	1800 570	1780 630	1780 705	1700 695	1530 615
	NORMAL (400 CFM/TON)	OFF	OFF	OFF	OFF	CFM WATTS	2050 845	2010 875	1860 805	1710 735	1530 655
	HIGH (450 CFM/TON)	OFF	OFF	ON	OFF	CFM WATTS	2160 995	2040 935	1920 875	1780 805	1620 730

NOTES: * First letter may be "A" or "T"
 1. At continuous fan setting: Heating or Cooling airflows are approximately 50% of selected cooling value.
 2. LOW airflow (350 cfm/ton) is COMFORT & HUMID CLIMATE setting;
 NORMAL airflow (400 cfm/ton) is typical setting;
 HIGH airflow (450 cfm/ton) is DRY CLIMATE setting.

*DH2B060A9V3V FURNACE HEATING AIRFLOW (CFM) AND POWER (WATTS) VS. EXTERNAL STATIC PRESSURE WITH FILTER									
1st STAGE CAPACITY = 37,440 2nd STAGE CAPACITY = 57,600									
	AIRFLOW SETTING	DIP SWITCH SETTING			EXTERNAL STATIC PRESSURE				
		SW 7	SW 8		0.1	0.3	0.5	0.7	0.9
HEATING 1ST STAGE	LOW	ON	ON	CFM TEMP. RISE WATTS	600 56 55	600 56 85	600 56 120	600 56 150	600 56 185
	MEDIUM LOW	OFF	ON	CFM TEMP. RISE WATTS	675 50 65	675 50 105	675 50 140	675 50 175	675 50 205
	NORMAL **	ON	OFF	CFM TEMP. RISE WATTS	750 45 85	750 45 125	750 45 160	750 45 210	750 45 260
	HIGH	OFF	OFF	CFM TEMP. RISE WATTS	850 40 115	850 40 155	850 40 205	850 40 260	850 40 320
HEATING 2ND STAGE	LOW	ON	ON	CFM TEMP. RISE WATTS	900 58 125	900 58 165	900 58 220	900 58 270	900 58 315
	MEDIUM LOW	OFF	ON	CFM TEMP. RISE WATTS	1000 52 170	1050 50 230	1050 50 295	1050 50 335	1050 50 370
	NORMAL **	ON	OFF	CFM TEMP. RISE WATTS	1100 47 215	1150 45 285	1150 45 340	1150 45 395	1100 47 440
	HIGH	OFF	OFF	CFM TEMP. RISE WATTS	1300 40 330	1325 39 385	1325 39 455	1250 42 465	1200 43 470

NOTES:
 * First letter may be "A" or "T"
 ** Factory setting

*DH2B060A9V3V FURNACE COOLING AIRFLOW (CFM) AND POWER (WATTS) VS. EXTERNAL STATIC PRESSURE WITH FILTER											
OUTDOOR UNIT SIZE (TONS)	AIRFLOW SETTING	DIP SWITCH SETTING					EXTERNAL STATIC PRESSURE				
		SW 1	SW 2	SW 3	SW 4		0.1	0.3	0.5	0.7	0.9
1.5	LOW (350 CFM/TON)	OFF	OFF	OFF	ON	CFM WATTS	525 45	525 70	525 100	525 135	525 160
	NORMAL (400 CFM/TON)	OFF	OFF	OFF	OFF	CFM WATTS	600 55	600 85	600 120	600 150	600 185
	HIGH (450 CFM/TON)	OFF	OFF	ON	OFF	CFM WATTS	675 65	675 105	625 140	675 175	675 205
2.0	LOW (350 CFM/TON)	ON	ON	OFF	ON	CFM WATTS	700 70	700 115	700 145	700 185	700 220
	NORMAL (400 CFM/TON)	ON	ON	OFF	OFF	CFM WATTS	800 100	800 135	800 175	800 225	800 280
	HIGH (450 CFM/TON)	ON	ON	ON	OFF	CFM WATTS	900 125	900 165	900 220	900 270	900 330
2.5	LOW (350 CFM/TON)	OFF	ON	OFF	ON	CFM WATTS	875 115	875 160	875 210	875 260	875 310
	NORMAL (400 CFM/TON)	OFF	ON	OFF	OFF	CFM WATTS	1000 150	1000 207	1000 265	1000 320	1000 380
	HIGH (450 CFM/TON)	OFF	ON	ON	OFF	CFM WATTS	1125 215	1125 285	1125 340	1125 395	1125 440
3	LOW (350 CFM/TON)	ON	OFF	OFF	ON	CFM WATTS	1050 175	1050 240	1050 305	1050 345	1050 380
	NORMAL (400 CFM/TON)	ON	OFF	OFF	OFF	CFM WATTS	1200 240	1200 315	1200 385	1200 440	1100 410
	HIGH (450 CFM/TON)	ON	OFF	ON	OFF	CFM WATTS	1350 330	1350 410	1350 500	1275 485	1170 450

NOTES: * First letter may be "A" or "T"
 1. At continuous fan setting: Heating or Cooling airflows are approximately 50% of selected cooling value.
 2. LOW airflow (350 cfm/ton) is COMFORT & HUMID CLIMATE setting;
 NORMAL airflow (400 cfm/ton) is typical setting;
 HIGH airflow (450 cfm/ton) is DRY CLIMATE setting.

*DH2B080A9V3V FURNACE HEATING AIRFLOW (CFM) AND POWER (WATTS) VS. EXTERNAL STATIC PRESSURE WITH FILTER									
					1st STAGE CAPACITY = 49,920 2nd STAGE CAPACITY = 76,800				
	AIRFLOW SETTING	DIP SWITCH SETTING			EXTERNAL STATIC PRESSURE				
		SW 7	SW 8		0.1	0.3	0.5	0.7	0.9
HEATING 1ST STAGE	LOW	ON	ON	CFM TEMP. RISE WATTS	800 56 130	800 56 170	800 56 210	790 56 245	-
	MEDIUM LOW	OFF	ON	CFM TEMP. RISE WATTS	900 49 162	900 49 210	900 49 260	900 49 295	-
	NORMAL **	ON	OFF	CFM TEMP. RISE WATTS	1000 44 205	1000 44 265	1000 44 310	1000 44 345	800 56 295
	HIGH	OFF	OFF	CFM TEMP. RISE WATTS	1170 38 305	1170 38 350	1170 38 400	1020 44 360	830 54 310
HEATING 2ND STAGE	LOW	ON	ON	CFM TEMP. RISE WATTS	1150 60 285	1150 60 345	1150 60 385	1020 67*** 360	830 83*** 305
	MEDIUM LOW	OFF	ON	CFM TEMP. RISE WATTS	1275 54 380	1275 54 445	1200 57 425	1040 66*** 380	900 76*** 350
	NORMAL **	ON	OFF	CFM TEMP. RISE WATTS	1430 48 515	1340 51 490	1220 56 455	1090 63 410	930 74*** 380
	HIGH	OFF	OFF	CFM TEMP. RISE WATTS	1430 48 515	1340 51 490	1220 56 455	1090 63 410	930 74*** 380

NOTES: * - First letter may be "A" or "T"
 ** Factory setting
 *** Above MAX Temperature change value

*DH2B080A9V3V - FURNACE COOLING AIRFLOW (CFM) AND POWER (WATTS) VS. EXTERNAL STATIC PRESSURE WITH FILTER											
OUTDOOR UNIT SIZE (TONS)	AIRFLOW SETTING	DIP SWITCH SETTING					EXTERNAL STATIC PRESSURE				
		SW 1	SW 2	SW 3	SW 4		0.1	0.3	0.5	0.7	0.9
2.0	LOW (350 CFM/TON)	ON	ON	OFF	ON	CFM WATTS	700 95	700 105	700 115	680 200	670 235
	NORMAL (400 CFM/TON)	ON	ON	OFF	OFF	CFM WATTS	800 130	800 160	800 205	790 245	740 265
	HIGH (450 CFM/TON)	ON	ON	ON	OFF	CFM WATTS	900 160	900 215	900 255	900 300	750 270
2.5	LOW (350 CFM/TON)	OFF	ON	OFF	ON	CFM WATTS	875 145	875 185	875 240	875 280	760 270
	NORMAL (400 CFM/TON)	OFF	ON	OFF	OFF	CFM WATTS	1000 205	1000 265	1000 310	1000 340	800 295
	HIGH (450 CFM/TON)	OFF	ON	ON	OFF	CFM WATTS	1150 295	1150 340	1150 385	1020 350	800 300
3.0	LOW (350 CFM/TON)	ON	OFF	OFF	ON	CFM WATTS	1050 235	1050 295	1050 340	1010 350	800 290
	NORMAL (400 CFM/TON)	ON	OFF	OFF	OFF	CFM WATTS	1200 335	1200 385	1200 410	1040 365	840 310
	HIGH (450 CFM/TON)	ON	OFF	ON	OFF	CFM WATTS	1350 455	1350 480	1210 435	1070 390	900 345

NOTES: * First letter may be "A" or "T"
 1. At continuous fan setting: Heating or Cooling airflows are approximately 50% of selected cooling value.
 2. LOW airflow (350 cfm/ton) is COMFORT & HUMID CLIMATE setting;
 NORMAL airflow (400 cfm/ton) is typical setting;
 HIGH airflow (450 cfm/ton) is DRY CLIMATE setting.

*DH2B080A9V4V FURNACE HEATING AIRFLOW (CFM) AND POWER (WATTS) VS. EXTERNAL STATIC PRESSURE WITH FILTER									
1st STAGE CAPACITY = 49,400 2nd STAGE CAPACITY = 76,000									
	AIRFLOW SETTING	DIP SWITCH SETTING			EXTERNAL STATIC PRESSURE				
		SW 7	SW 8		0.1	0.3	0.5	0.7	0.9
HEATING 1ST STAGE	LOW	ON	ON	CFM TEMP. RISE WATTS	800 56 130	800 56 170	800 56 210	790 56 245	-
	MEDIUM LOW	OFF	ON	CFM TEMP. RISE WATTS	900 49 162	900 49 210	900 49 260	900 49 295	-
	MEDIUM **	ON	OFF	CFM TEMP. RISE WATTS	1000 44 205	1000 44 265	1000 44 310	1000 44 345	800 56 295
	HIGH	OFF	OFF	CFM TEMP. RISE WATTS	1170 38 305	1170 38 350	1170 38 400	1020 44 360	830 54 310
HEATING 2ND STAGE	LOW	ON	ON	CFM TEMP. RISE WATTS	1150 60 285	1150 60 345	1150 60 385	1020 67*** 360	830 83*** 305
	MEDIUM LOW	OFF	ON	CFM TEMP. RISE WATTS	1275 54 380	1275 54 445	1200 57 425	1040 66*** 380	900 76*** 350
	MEDIUM **	ON	OFF	CFM TEMP. RISE WATTS	1430 48 515	1340 51 490	1220 56 455	1090 63 410	930 74*** 380
	HIGH	OFF	OFF	CFM TEMP. RISE WATTS	1430 48 515	1340 51 490	1220 56 455	1090 63 410	930 74*** 380

NOTES: * - First letter may be "A" or "T"
 ** Factory setting
 *** Above MAX Temperature change value

*DH2B080A9V4V - FURNACE COOLING AIRFLOW (CFM) AND POWER (WATTS) VS. EXTERNAL STATIC PRESSURE WITH FILTER											
OUTDOOR UNIT SIZE (TONS)	AIRFLOW SETTING	DIP SWITCH SETTING					EXTERNAL STATIC PRESSURE				
		SW 1	SW 2	SW 3	SW 4		0.1	0.3	0.5	0.7	0.9
2.5	LOW (350 CFM/TON)	ON	ON	OFF	ON	CFM WATTS	849 141	865 191	881 241	878 294	876 348
	NORMAL (400 CFM/TON)	ON	ON	OFF	OFF	CFM WATTS	953 195	965 250	977 305	973 358	970 411
	HIGH (450 CFM/TON)	ON	ON	ON	OFF	CFM WATTS	1057 249	1065 309	1073 369	1069 422	1064 474
3.0	LOW (350 CFM/TON)	OFF	ON	OFF	ON	CFM WATTS	999 188	1003 241	1008 394	1018 354	1029 414
	NORMAL (400 CFM/TON)	OFF	ON	OFF	OFF	CFM WATTS	1144 300	1150 362	1156 423	1160 486	1165 548
	HIGH (450 CFM/TON)	OFF	ON	ON	OFF	CFM WATTS	1288 412	1297 482	1305 552	1303 617	1300 682
3.5	LOW (350 CFM/TON)	ON	OFF	OFF	ON	CFM WATTS	1156 307	1165 374	1174 440	1177 502	1179 563
	NORMAL (400 CFM/TON)	ON	OFF	OFF	OFF	CFM WATTS	1327 446	1335 518	1343 589	1325 641	1307 693
	HIGH (450 CFM/TON)	ON	OFF	ON	OFF	CFM WATTS	1506 634	1502 703	1498 771	1418 746	1338 721
4.0	LOW (350 CFM/TON)	OFF	OFF	OFF	ON	CFM WATTS	1327 446	1335 518	1343 589	1325 641	1307 693
	NORMAL (400 CFM/TON)	OFF	OFF	OFF	OFF	CFM WATTS	1525 656	1522 727	1518 797	1430 761	1341 725
	HIGH (450 CFM/TON)	OFF	OFF	ON	OFF	CFM WATTS	1706 906	1635 881	1563 857	1471 813	1379 769

NOTES: * First letter may be "A" or "T"
 1. At continuous fan setting: Heating or Cooling airflows are approximately 50% of selected cooling value.
 2. LOW airflow (350 cfm/ton) is COMFORT & HUMID CLIMATE setting;
 NORMAL airflow (400 cfm/ton) is typical setting;
 HIGH airflow (450 cfm/ton) is DRY CLIMATE setting.

*DH2C100A9V4V - FURNACE HEATING AIRFLOW (CFM) AND POWER (WATTS) VS. EXTERNAL STATIC PRESSURE WITH FILTER									
					1st STAGE CAPACITY = 62,400				
					2nd STAGE CAPACITY = 96,000				
	AIRFLOW SETTING	DIP SWITCH SETTING			EXTERNAL STATIC PRESSURE				
		SW 7	SW 8		0.1	0.3	0.5	0.7	0.9
HEATING 1ST STAGE	LOW	ON	ON	CFM TEMP. RISE WATTS	923 61 110	955 59 165	960 58 210	958 58 265	947 59 310
	MEDIUM LOW	OFF	ON	CFM TEMP. RISE WATTS	1020 55 145	1047 53 190	1053 53 250	1042 54 295	1029 54 350
	MEDIUM **	ON	OFF	CFM TEMP. RISE WATTS	1156 48 185	1166 48 240	1172 48 300	1177 48 350	1178 48 420
	HIGH	OFF	OFF	CFM TEMP. RISE WATTS	1275 44 225	1305 43 290	1328 42 365	1328 42 445	1328 42 510
HEATING 2ND STAGE	LOW	ON	ON	CFM TEMP. RISE WATTS	1298 66 235	1320 65 305	1335 65 380	1343 64 445	1343 64 520
	MEDIUM LOW	OFF	ON	CFM TEMP. RISE WATTS	1439 60 310	1459 59 390	1482 58 470	1483 58 550	1470 59 610
	MEDIUM **	ON	OFF	CFM TEMP. RISE WATTS	1639 53 430	1650 52 525	1650 52 600	1644 52 680	1496 58 640
	HIGH	OFF	OFF	CFM TEMP. RISE WATTS	1790 18 570	1818 47 670	1813 47 770	1708 50 750	1535 56 675

NOTES: * - First letter may be "A" or "T"
 ** Factory setting
 *** Above MAX temperature change

*DH2C100A9V4V - FURNACE COOLING AIRFLOW (CFM) AND POWER (WATTS) VS. EXTERNAL STATIC PRESSURE WITH FILTER											
OUTDOOR UNIT SIZE (TONS)	AIRFLOW SETTING	DIP SWITCH SETTING					EXTERNAL STATIC PRESSURE				
		SW 1	SW 2	SW 3	SW 4		0.1	0.3	0.5	0.7	0.9
2.5	LOW (350 CFM/TON)	ON	ON	OFF	ON	CFM WATTS	870 100	885 140	887 185	881 230	876 270
	NORMAL (400 CFM/TON)	ON	ON	OFF	OFF	CFM WATTS	989 120	1018 180	1016 230	1012 285	999 325
	HIGH (450 CFM/TON)	ON	ON	ON	OFF	CFM WATTS	1124 175	1139 225	1130 275	1135 335	1135 390
3.0	LOW (350 CFM/TON)	OFF	ON	OFF	ON	CFM WATTS	1053 145	1075 200	1070 245	1070 295	1049 350
	NORMAL (400 CFM/TON)	OFF	ON	OFF	OFF	CFM WATTS	1186 195	1205 255	1220 310	1220 370	1216 440
	HIGH (450 CFM/TON)	OFF	ON	ON	OFF	CFM WATTS	1336 255	1366 340	1383 405	1385 470	1381 545
3.5	LOW (350 CFM/TON)	ON	OFF	OFF	ON	CFM WATTS	1216 190	1225 255	1235 320	1240 385	1243 445
	NORMAL (400 CFM/TON)	ON	OFF	OFF	OFF	CFM WATTS	1394 270	1422 360	1436 430	1437 505	1430 580
	HIGH (450 CFM/TON)	ON	OFF	ON	OFF	CFM WATTS	1579 395	1604 475	1610 555	1599 645	1517 640
4.0	LOW (350 CFM/TON)	OFF	OFF	OFF	ON	CFM WATTS	1377 270	1412 355	1426 430	1433 510	1428 575
	NORMAL (400 CFM/TON)	OFF	OFF	OFF	OFF	CFM WATTS	1599 425	1624 510	1636 585	1618 670	1512 635
	HIGH (450 CFM/TON)	OFF	OFF	ON	OFF	CFM WATTS	1801 580	1818 690	1815 775	1694 735	1525 660

NOTES: * - First letter may be "A" or "T"
 1. At continuous fan setting: Heating or Cooling airflows are approximately 50% of selected cooling value.
 2. LOW airflow (350 cfm/ton) is COMFORT & HUMID CLIMATE setting;
 NORMAL airflow (400 cfm/ton) is typical setting;
 HIGH airflow (450 cfm/ton) is DRY CLIMATE setting.

*DH2D120A9V5V - FURNACE HEATING AIRFLOW (CFM) AND POWER (WATTS) VS. EXTERNAL STATIC PRESSURE WITH FILTER									
1st STAGE CAPACITY = 74,880 2nd STAGE CAPACITY = 115,200									
	AIRFLOW SETTING	DIP SWITCH SETTING			EXTERNAL STATIC PRESSURE				
		SW 8	SW 7		0.1	0.3	0.5	0.7	0.9
HEATING 1ST STAGE	LOW	ON	ON	CFM TEMP. RISE WATTS	1025 65 150	1025 65 200	1000 67 240	1000 67 290	1000 67 340
	MEDIUM LOW	OFF	ON	CFM TEMP. RISE WATTS	1200 56 230	1200 56 270	1200 56 330	1200 56 390	1200 56 450
	NORMAL **	ON	OFF	CFM TEMP. RISE WATTS	1350 49 280	1350 49 340	1350 49 490	1350 49 470	1350 49 530
	HIGH	OFF	OFF	CFM TEMP. RISE WATTS	1550 43 400	1550 43 490	1550 43 560	1550 43 620	1450 46 600
HEATING 2ND STAGE	LOW	ON	ON	CFM TEMP. RISE WATTS	1550 66 380	1550 66 470	1550 66 540	1550 66 610	1450 71*** 690
	MEDIUM LOW	OFF	ON	CFM TEMP. RISE WATTS	1850 56 660	1850 56 750	1850 56 780	1700 60 720	1500 69 640
	NORMAL **	ON	OFF	CFM TEMP. RISE WATTS	2050 50 860	2000 51 880	1850 56 810	1700 60 750	1550 66 670
	HIGH	OFF	OFF	CFM TEMP. RISE WATTS	2105 49 1000	2050 50 940	1900 54 880	1775 58 820	1625 63 750

NOTES:
* First letter may be "A" or "T"
** Factory setting

*DH2D120A9V5V - FURNACE COOLING AIRFLOW (CFM) AND POWER (WATTS) VS. EXTERNAL STATIC PRESSURE WITH FILTER											
OUTDOOR UNIT SIZE (TONS)	AIRFLOW SETTING	DIP SWITCH SETTING					EXTERNAL STATIC PRESSURE				
		SW 1	SW 2	SW 3	SW 4		0.1	0.3	0.5	0.7	0.9
3.5	LOW (350 CFM/TON)	OFF	ON	OFF	ON	CFM WATTS	1225 240	1225 280	1225 340	1225 400	1225 450
	NORMAL (400 CFM/TON)	OFF	ON	OFF	OFF	CFM WATTS	1400 310	1400 390	1400 470	1400 520	1400 570
	HIGH (450 CFM/TON)	OFF	ON	ON	OFF	CFM WATTS	1600 450	1600 520	1600 590	1600 640	1450 600
4.0	LOW (350 CFM/TON)	ON	OFF	OFF	ON	CFM WATTS	1400 300	1400 380	1400 450	1400 520	1400 570
	NORMAL (400 CFM/TON)	ON	OFF	OFF	OFF	CFM WATTS	1600 460	1600 530	1600 610	1600 670	1450 600
	HIGH (450 CFM/TON)	ON	OFF	ON	OFF	CFM WATTS	1800 610	1800 700	1800 760	1650 690	1500 630
5	LOW (350 CFM/TON)	OFF	OFF	OFF	ON	CFM WATTS	1750 580	1750 640	1750 720	1650 680	1450 610
	NORMAL (400 CFM/TON)	OFF	OFF	OFF	OFF	CFM WATTS	2000 830	2000 860	1850 800	1700 740	1550 660
	HIGH (450 CFM/TON)	OFF	OFF	ON	OFF	CFM WATTS	2100 970	2000 910	1900 850	1650 780	1600 710

NOTES: * - First letter may be "A" or "T"
1. At continuous fan setting: Heating or Cooling airflows are approximately 50% of selected cooling value.
2. LOW airflow (350 cfm/ton) is COMFORT & HUMID CLIMATE setting;
NORMAL airflow (400 cfm/ton) is typical setting;
HIGH airflow (450 cfm/ton) is DRY CLIMATE setting.



Maximum Vent Length Table

VENT LENGTH TABLE			
ALTITUDE	MAXIMUM TOTAL EQUIVALENT LENGTH IN FEET FOR VENT AND INLET AIR (SEE NOTES)		
0-7,000 Feet	2 INCH PIPE	2.5 INCH PIPE	3 or 4 INCH PIPE
*UH/DH2B060A9V3VA	200	200	200
*UH/DH2B080A9V3VA *UH/DH2B080A9V4VA	50	120	200
*UH/DH2C100A9V4VA *UH2C100A9V5VA	Not Allowed	60	200
*UH/DH2D120A9V5VA	Not Allowed	Not Allowed	200
7,000-9,500 Feet	2 INCH PIPE	2.5 INCH PIPE	3 or 4 INCH PIPE
*UH/DH2B060A9V3VA	100	100	100
*UH/DH2B080A9V3VA *UH/DH2B080A9V4VA	25	60	100
*UH/DH2C100A9V4VA *UH2C100A9V5VA	Not Allowed	30	100
*UH/DH2D120A9V5VA	Not Allowed	Not Allowed	100
9,500-12,000 Feet	2 INCH PIPE	2.5 INCH PIPE	3 or 4 INCH PIPE
*UH/DH2B060A9V3VA	50	50	50
*UH/DH2B080A9V3VA *UH/DH2B080A9V4VA	Not Allowed	30	50
*UH/DH2C100A9V4VA *UH2C100A9V5VA	Not Allowed	Not Allowed	50
*UH/DH2D120A9V5VA	Not Allowed	Not Allowed	50

NOTES: * - First letter may be "A" or "T"

1. Minimum vent length for all models: 3' horizontal or 3' vertical.
2. DO NOT MIX PIPE DIAMETERS IN THE SAME LENGTH OF PIPE OUTSIDE THE FURNACE CABINET (Except adapters at the top of the furnace). If different inlet and vent pipe sizes are used, the vent pipe must adhere to the maximum length limit shown in the table above (See note 6 below for exception). The inlet pipe can be of a larger diameter, but never smaller than the vent pipe.
3. MAXIMUM PIPE LENGTHS MUST NOT BE EXCEEDED! THE LENGTH SHOWN IS NOT A COMBINED TOTAL, IT IS THE MAXIMUM LENGTH OF EACH (Vent or Inlet air pipes).
4. One SHORT radius 90° elbow is equivalent to 10' of 3" or 4" pipe and one LONG radius elbow is equivalent to 6' of 3" or 4" pipe. One 90° elbow is equivalent to 7½' of 2½" pipe or 5' of 2" pipe. Two 45° elbows equal one 90° elbow.
5. The termination tee or bend must be included in the total number of elbows. If the BAYAIR30AVENTA termination kit is used, the equivalent length of pipe is 5 feet. BAYVENT200B equivalent length is 0 feet.
6. Pipe adapters are field supplied (except for the *UH/DH2D120 models).
7. For Canadian applications ONLY, IPEX 196006 may be used for horizontal and vertical terminations. IPEX 081216, IPEX 081218, and IPEX 081219 may only be used for horizontal vent terminations. Equivalent lengths are IPEX 196009 = 5 feet, IPEX 081216 = 11 feet, IPEX 081218 = 16 feet, and IPEX 081219 = 21 feet

Electrical Data

*UH2 WIRING DIAGRAM

IMPORTANT:
INTEGRATED CONTROL IS POLARITY SENSITIVE.
HOT LEG OF 120V POWER SUPPLY MUST BE
CONNECTED TO THE BLACK POWER LEAD AS
INDICATED ON WIRING DIAGRAM.

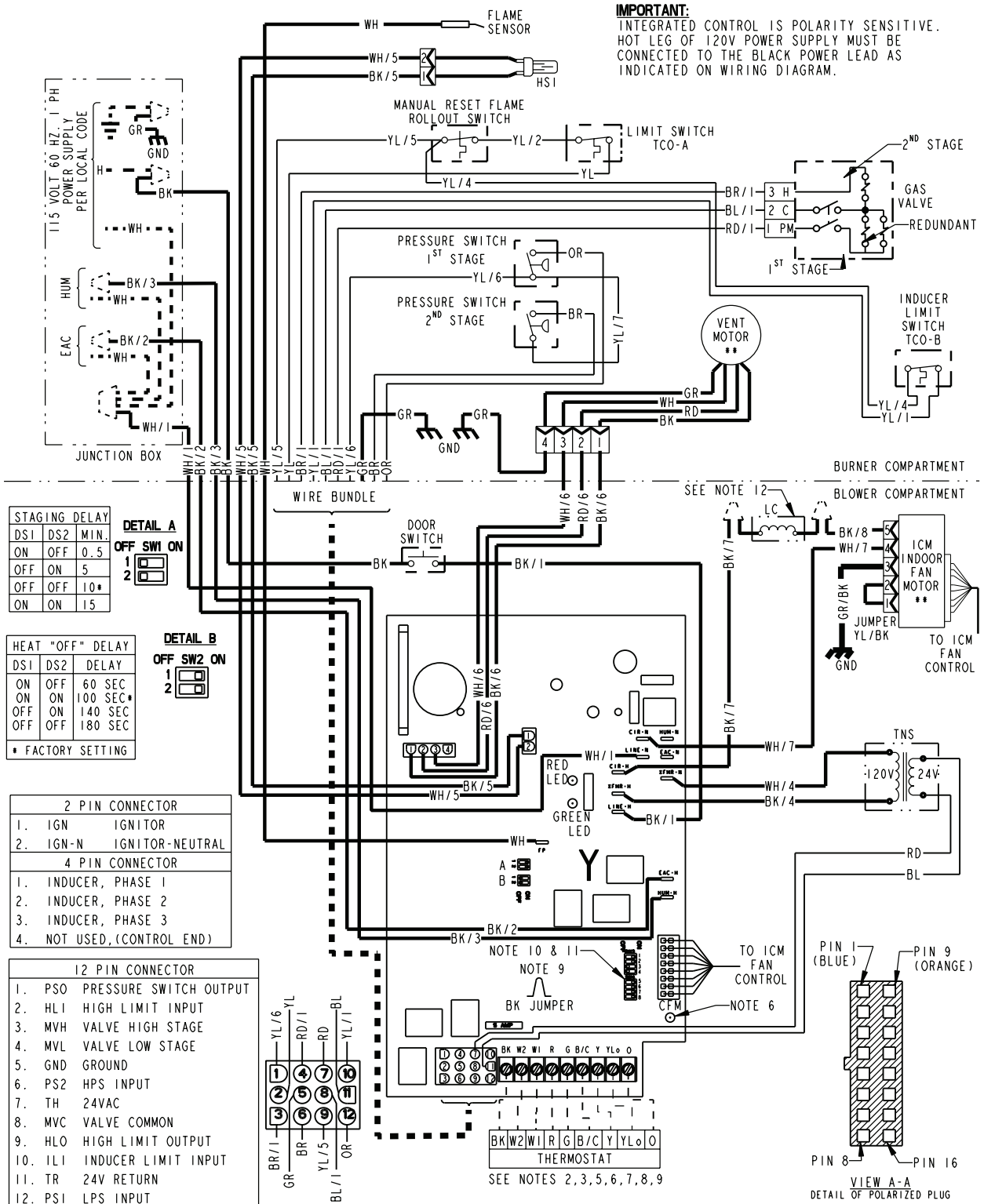

STAGING DELAY		
DS1	DS2	MIN.
ON	OFF	0.5
OFF	ON	5
OFF	OFF	10*
ON	ON	15



HEAT "OFF" DELAY		
DS1	DS2	DELAY
ON	OFF	60 SEC
ON	ON	100 SEC*
OFF	ON	140 SEC
OFF	OFF	180 SEC



* FACTORY SETTING

2 PIN CONNECTOR	
1.	IGN IGNITOR
2.	IGN-N IGNITOR-NEUTRAL

4 PIN CONNECTOR	
1.	INDUCER, PHASE 1
2.	INDUCER, PHASE 2
3.	INDUCER, PHASE 3
4.	NOT USED, (CONTROL END)

12 PIN CONNECTOR	
1.	PSO PRESSURE SWITCH OUTPUT
2.	HLI HIGH LIMIT INPUT
3.	MVH VALVE HIGH STAGE
4.	MVL VALVE LOW STAGE
5.	GND GROUND
6.	PS2 HPS INPUT
7.	TH 24VAC
8.	MVC VALVE COMMON
9.	HLO HIGH LIMIT OUTPUT
10.	ILI INDUCER LIMIT INPUT
11.	TR 24V RETURN
12.	PSI LPS INPUT

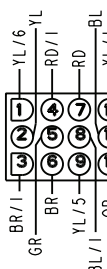

SEE NOTES 2, 3, 5, 6, 7, 8, 9

From drawing D344303

Electrical Data

*UH2 SCHEMATIC DIAGRAM

TABLE "A"	
MODELS	
*UH2B060A9V3V**	*UH2C100A9V4V**
*UH2B080A9V3V**	*UH2C100A9V5V**
*UH2B080A9V4V**	*UH2D120A9V5V**

* PREFIX MAY BE "A" OR "T"
 * SUFFIX MAY BE "A" THROUGH "Z"

WARNING

HAZARDOUS VOLTAGE:
DISCONNECT ALL ELECTRICAL POWER INCLUDING REMOTE DISCONNECTS BEFORE SERVICING.
FAILURE TO DISCONNECT POWER BEFORE SERVICING CAN CAUSE SEVERE PERSONAL INJURY OR DEATH.

CAUTION

USE COPPER CONDUCTORS ONLY!
UNIT TERMINALS ARE NOT DESIGNED TO ACCEPT OTHER TYPES OF CONDUCTORS.
FAILURE TO DO SO MAY CAUSE DAMAGE TO THE EQUIPMENT.

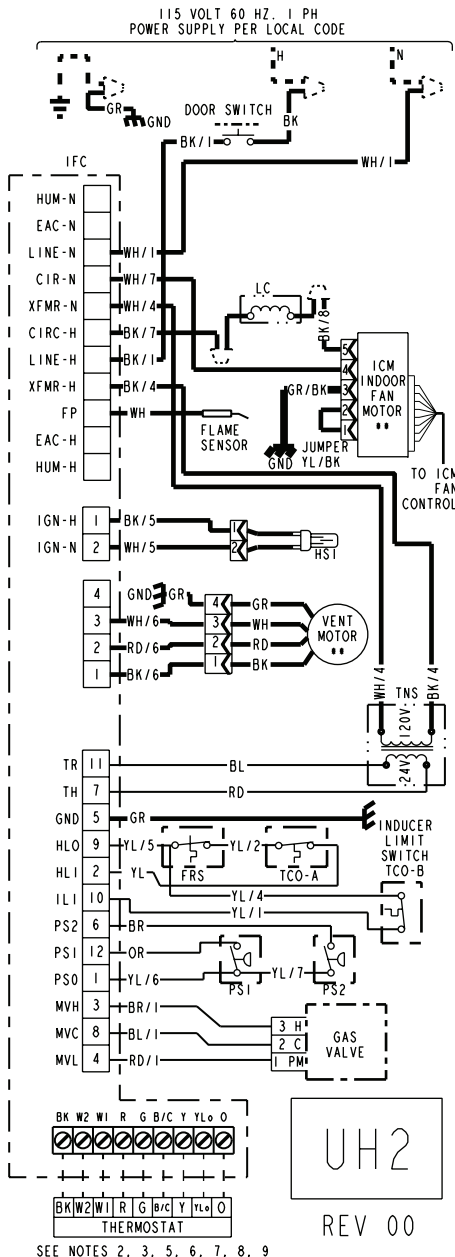

INTEGRATED FURNACE CONTROL
 REPLACE WITH PART CNT06017 OR EQUIVALENT

ELECTRICAL RATING
 INPUT: 25 VAC, 60 HZ
 XFMR SEC. CURRENT: 450 MA. + MV LOAD
 MV OUTPUT: 1.5 A @ 24 VAC
 IND OUTPUT: 3 PHASE OUTPUT
 IGN OUTPUT: 2.0 A @ 120 VAC
 CIRC. BLOWER OUTPUT: 14.5 FLA, 25 LRA @ 120 VAC
 HUMIDIFIER & AIR CLEANER
 MAX. LOAD: 1.0 A @ 120 VAC

TIMINGS
 PREPURGE: 0 SEC.; INTERPURGE: 60 SEC.
 POST PURGE: 5 SEC.
 IGN WARMUP: 20 SEC.
 IAP: 2; TFI: 5 SEC.
 RETRIES: 2 RECYCLES: 10
 HEAT ON DELAY: 45 SEC.
 COOL ON DELAY: 0 SEC.
 AUTO RESTART: 60 MIN.
 AUTO RESTART PURGE: 60 SEC.

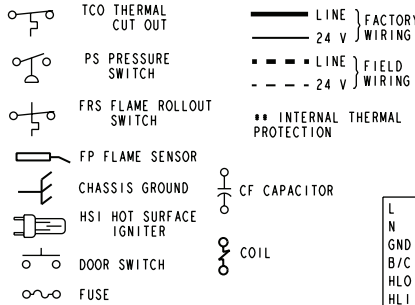

DIAGNOSTIC CODES

RED LED - LitePort™ DATA - 1 FLASH EVERY 20 SEC.
 2 FLASHES: RETRIES OR RECYCLES EXCEEDED
 3 FLASHES: INDUCER OR PRESSURE SWITCH ERROR
 4 FLASHES: OPEN LIMIT OR ROLLOUT SWITCH
 5 FLASHES: FLAME SENSED WHEN NO FLAME SHOULD BE PRESENT
 6 FLASHES: LINE REVERSE
 7 FLASHES: GAS VALVE CIRCUIT ERROR
 8 FLASHES: WEAK FLAME
 9 FLASHES: OPEN INDUCER LIMIT ERROR

GREEN LED - STATUS
 SLOW FLASH: NORMAL, NO CALL FOR HEAT
 FAST FLASH: NORMAL, CALL FOR HEAT PRESENT

GREEN AND RED LEDs ON CONTINUOUS:
 FUSE OPEN OR INTERNAL CONTROL FAILURE

BK	BLACK	GR	GREEN
WH	WHITE	BR	BROWN
YL	YELLOW	RD	RED
OR	ORANGE	BL	BLUE

WIRE COLOR

BK/1 NUMBER ID (IF ANY)

L	LINE	TH	24 VAC (HOT)
N	NEUTRAL	TR	24 VAC (COMMON)
GND	GROUND	MV	MAIN GAS VALVE
B/C	COMMON	TNS	TRANSFORMER
HLO	HIGH LIMIT OUTPUT	ILI	INDUCER LIMIT INPUT
HLI	HIGH LIMIT INPUT		

NOTES:

- IF ANY OF THE ORIGINAL WIRING AS SUPPLIED WITH THIS FURNACE MUST BE REPLACED, IT MUST BE WITH WIRE HAVING A TEMPERATURE RATING OF AT LEAST 105°C.
- THERMOSTAT HEAT ANTICIPATOR SETTING: FIRST STAGE .38 AMPS, SECOND STAGE .13 AMPS. IF SETTING IS NOT FIXED ON THERMOSTAT, FOR SINGLE STAGE HEATING THERMOSTAT SET AT .51 AMPS.
- FOR PROPER OPERATION OF COOLING SPEED, "Y" TERMINAL MUST BE CONNECTED TO THE ROOM THERMOSTAT.
- THESE LEADS PROVIDE 120V POWER CONNECTIONS FOR ELECTRONIC AIR CLEANER (EAC) AND HUMIDIFIER (HUM). MAX. LOAD: 1.0 AMPS EACH.
- JUMPER W1 AND W2 FOR SINGLE STAGE HEATING THERMOSTAT, SECOND STAGE WILL BE ENERGIZED, DELAYED PER STAGING DELAY SETTING.
- GREEN LIGHT (CFM) FLASHES ONCE PER 100 CFM COMMAND.
- FOR HEAT PUMP SYSTEMS Y AND O MUST BE CONNECTED TO THE LOW-VOLTAGE TERMINAL BOARD.
- FOR TWO COMPRESSOR SYSTEMS, USE "YLO" FOR LOW SPEED AND "Y" FOR HIGH SPEED CONNECTION TO THE LOW-VOLTAGE TERMINAL BOARD.
- OPTIONAL HUMIDISTAT IS TO BE CONNECTED BETWEEN THE "R" AND "BK". FACTORY INSTALLED JUMPER "R" TO "BK" (BK JUMPER) ON THE CIRCUIT BOARD MUST BE CUT IF OPTIONAL HUMIDISTAT IS USED. THE JUMPER MUST ALSO BE CUT WHEN APPLYING AN AIRFLOW COMMAND SIGNAL TO THE "BK" INPUT SUCH AS WITH THE VARIABLE SPEED SINGLE-ZONE AND MULTI-ZONE SYSTEM CONTROLLERS. ON SINGLE SPEED COOLING ONLY / NON-HEAT PUMP SYSTEMS, JUMPER "Y" TO "O" FOR PROPER OPERATION OF THE DELAY PROFILES AND THE HUMIDISTAT. FOR TWO COMPRESSOR OR TWO SPEED SYSTEMS, JUMPER "YLO" TO "O".
- SEE INDOOR MOTOR AIRFLOW SELECTION CHART, LOCATED IN THE FURNACE FOR DIP SWITCH SETTINGS TO SET AIRFLOW AND COOLING OFF DELAYS.
- POWER MUST BE OFF WHEN DIP SWITCHES ARE SET.
- USED FOR *UH2B080A9V4V**, *UH2C100A9V4V**, *UH2C100A9V5V** & *UH2D120A9V5V**.
- ON POWER-UP, LAST FOUR FAULTS, IF ANY, WILL BE FLASHED ON RED LED. GREEN LED WILL BE SOLID ON DURING LAST FAULT RECOVERY.

UH2

REV 00

SEE NOTES 2, 3, 5, 6, 7, 8, 9

Electrical Data

*DH2 WIRING DIAGRAM

DETAIL A
OFF SW1 ON

STAGING DELAY		
DS1	DS2	MIN.
ON	OFF	0.5
OFF	ON	5
OFF	OFF	10*
ON	ON	15

DETAIL B
OFF SW2 ON

HEAT "OFF" DELAY		
DS1	DS2	DELAY
ON	OFF	60 SEC
ON	ON	100 SEC*
OFF	ON	140 SEC
OFF	OFF	180 SEC

* FACTORY SETTING

2 PIN CONNECTOR

- IGN IGNITOR
- IGN-N IGNITOR-NEUTRAL

4 PIN CONNECTOR

- INDUCER, PHASE 1
- INDUCER, PHASE 2
- INDUCER, PHASE 3
- NOT USED, (CONTROL END)

12 PIN CONNECTOR

- PSO PRESSURE SWITCH OUTPUT
- HLI HIGH LIMIT INPUT
- MVH VALVE HIGH STAGE
- MVL VALVE LOW STAGE
- GND GROUND
- PS2 HPS INPUT
- TH 24VAC
- MVC VALVE COMMON
- HLO HIGH LIMIT OUTPUT
- ILI INDUCER LIMIT INPUT
- TR 24V RETURN
- PSI LPS INPUT

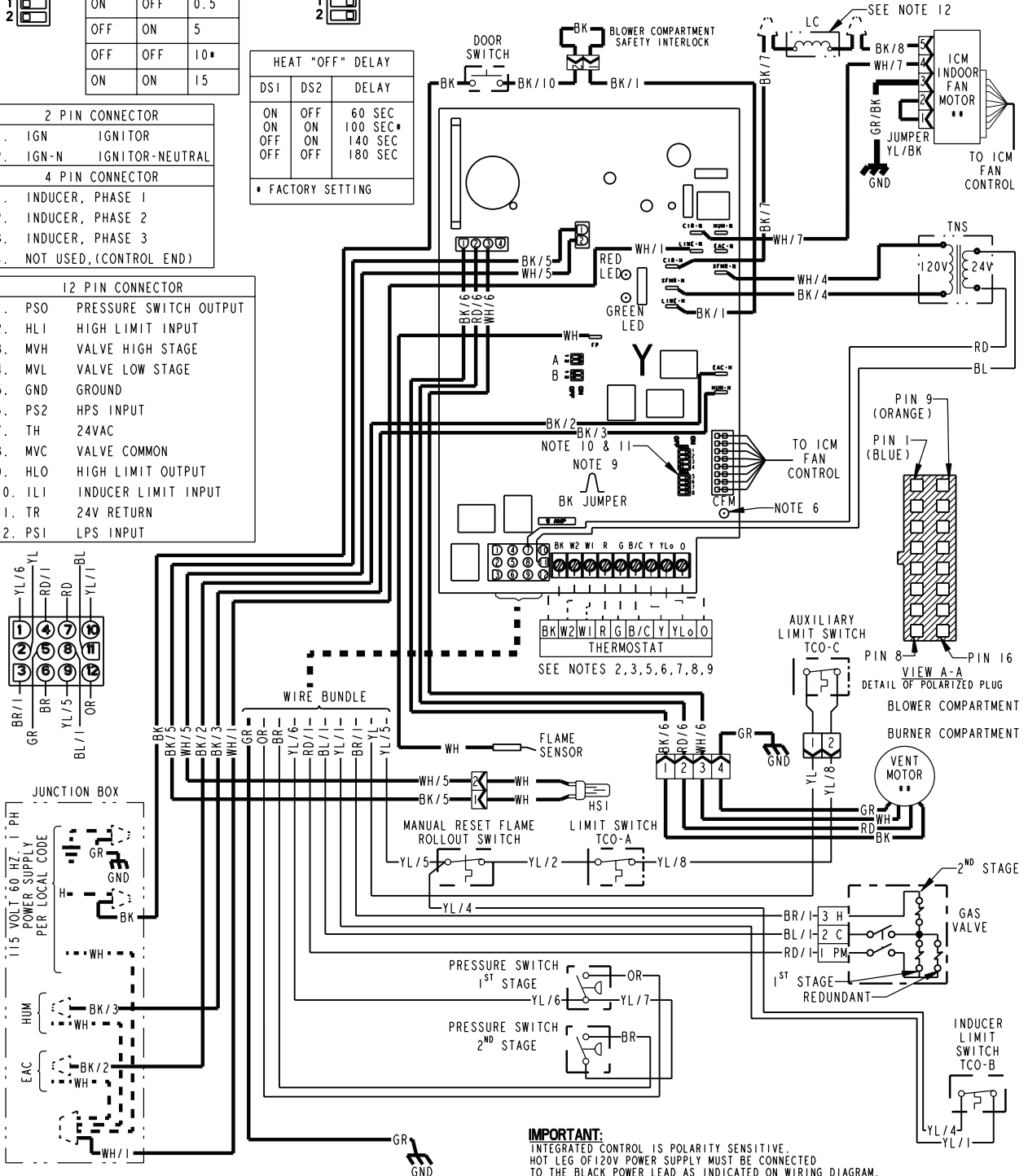

IMPORTANT:
INTEGRATED CONTROL IS POLARITY SENSITIVE.
HOT LEG OF 120V POWER SUPPLY MUST BE CONNECTED
TO THE BLACK POWER LEAD AS INDICATED ON WIRING DIAGRAM.

From drawing D344304

Electrical Data

*DH2 SCHEMATIC DIAGRAM

TABLE "A"	
MODELS	
*DH2B060A9V3V**	*DH2C100A9V4V**
*DH2B080A9V3V**	*DH2D120A9V5V**
*DH2B080A9V4V**	

* PREFIX MAY BE "A" OR "T"
* SUFFIX MAY BE "A" THROUGH "Z"

WARNING

HAZARDOUS VOLTAGE:
DISCONNECT ALL ELECTRICAL POWER INCLUDING REMOTE DISCONNECTS BEFORE SERVICING.
FAILURE TO DISCONNECT POWER BEFORE SERVICING CAN CAUSE SEVERE PERSONAL INJURY OR DEATH.

CAUTION

USE COPPER CONDUCTORS ONLY!
UNIT TERMINALS ARE NOT DESIGNED TO ACCEPT OTHER TYPES OF CONDUCTORS.
FAILURE TO DO SO MAY CAUSE DAMAGE TO THE EQUIPMENT.

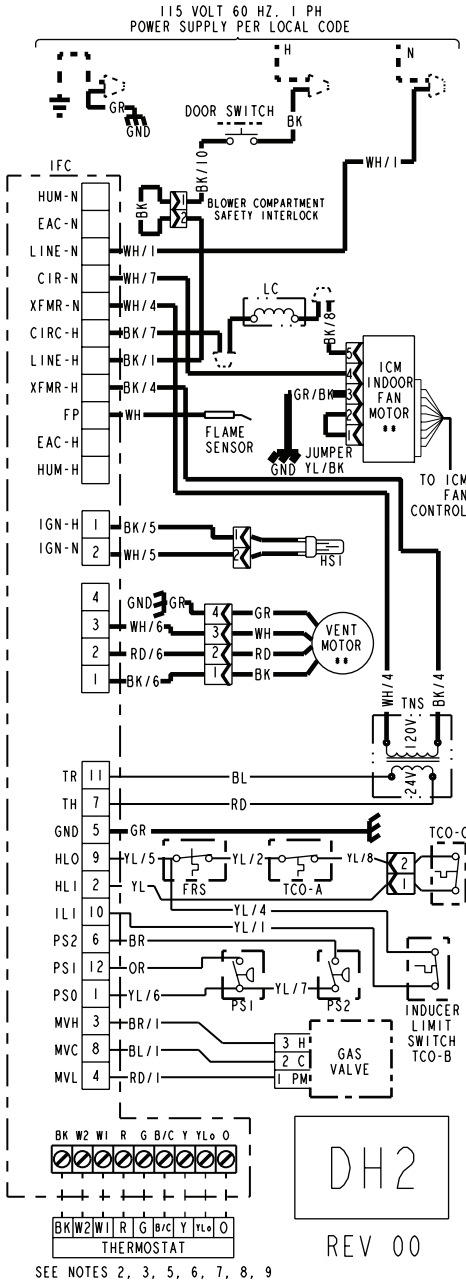

INTEGRATED FURNACE CONTROL
REPLACE WITH PART CNT06017 OR EQUIVALENT
ELECTRICAL RATING
INPUT: 25 VAC, 60 HZ.
XFMR SEC. CURRENT: 450 MA. + MV LOAD
MV OUTPUT: 1.5 A @ 24 VAC
IND OUTPUT: 3 PHASE OUTPUT
IGN OUTPUT: 2.0 A @120 VAC
CIRC. BLOWER OUTPUT: 14.5 FLA.
25 LRA @ 120 VAC
HUMIDIFIER & AIR CLEANER
MAX. LOAD: 1.0 A @ 120 VAC

TIMINGS
PREPURGE: 0 SEC.; INTERPURGE: 60 SEC.
POST PURGE: 5 SEC.
IGN WARMUP: 20 SEC.
IAP: 2; TFI: 5 SEC.
RETRIES: 2 RECYCLES: 10
HEAT ON DELAY: 45 SEC.
COOL ON DELAY: 0 SEC.
AUTO RESTART: 60 MIN.
AUTO RESTART PURGE: 60 SEC.

DIAGNOSTIC CODES

RED LED - LifePort™ DATA - 1 FLASH EVERY 20 SEC.
2 FLASHES: RETRIES OR RECYCLES EXCEEDED
3 FLASHES: INDUCER OR PRESSURE SWITCH ERROR
4 FLASHES: OPEN LIMIT OR ROLLOUT SWITCH
5 FLASHES: FLAME SENSED WHEN NO FLAME SHOULD BE PRESENT
6 FLASHES: LINE REVERSE
7 FLASHES: GAS VALVE CIRCUIT ERROR
8 FLASHES: WEAK FLAME
9 FLASHES: OPEN INDUCER LIMIT ERROR

GREEN LED - STATUS
SLOW FLASH: NORMAL, NO CALL FOR HEAT
FAST FLASH: NORMAL, CALL FOR HEAT PRESENT

GREEN AND RED LED: ON CONTINUOUS:
FUZE OPEN OR INTERNAL CONTROL FAILURE

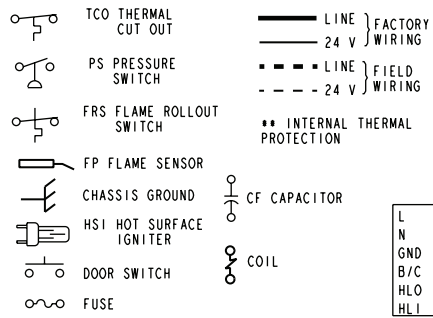

BK	BLACK	GR	GREEN
WH	WHITE	BR	BROWN
YL	YELLOW	RD	RED
OR	ORANGE	BL	BLUE

WIRE COLOR
BK/1 - NUMBER ID (IF ANY)

L	LINE	TH	24 VAC (HOT)
N	NEUTRAL	TR	24 VAC (COMMON)
GND	GROUND	MV	MAIN GAS VALVE
B/C	COMMON	TNS	TRANSFORMER
HLO	HIGH LIMIT OUTPUT	ILI	INDUCER LIMIT INPUT

- NOTES:**
- IF ANY OF THE ORIGINAL WIRING AS SUPPLIED WITH THIS FURNACE MUST BE REPLACED, IT MUST BE WITH WIRE HAVING A TEMPERATURE RATING OF AT LEAST 105°C.
 - THERMOSTAT HEAT ANTICIPATOR SETTING: FIRST STAGE .38 AMPS, SECOND STAGE .13 AMPS. IF SETTING IS NOT FIXED ON THERMOSTAT, FOR SINGLE STAGE HEATING THERMOSTAT SET AT .51 AMPS.
 - FOR PROPER OPERATION OF COOLING SPEED, "Y" TERMINAL MUST BE CONNECTED TO THE ROOM THERMOSTAT.
 - THESE LEADS PROVIDE 120V POWER CONNECTIONS FOR ELECTRONIC AIR CLEANER (EAC) AND HUMIDIFIER (HUM). MAX. LOAD: 1.0 AMPS EACH.
 - JUMPER W1 AND W2 FOR SINGLE STAGE HEATING THERMOSTAT, SECOND STAGE WILL BE ENERGIZED, DELAYED PER STAGING DELAY SETTING.
 - GREEN LIGHT (CFM) FLASHES ONCE PER 100 CFM COMMAND.
 - FOR HEAT PUMP SYSTEMS Y AND O MUST BE CONNECTED TO THE LOW-VOLTAGE TERMINAL BOARD.
 - FOR TWO COMPRESSOR SYSTEMS, USE "YLO" FOR LOW SPEED AND "Y" FOR HIGH SPEED CONNECTION TO THE LOW-VOLTAGE TERMINAL BOARD.
 - OPTIONAL HUMIDISTAT IS TO BE CONNECTED BETWEEN THE "R" AND "BK". FACTORY INSTALLED JUMPER "R" TO "BK" (BK JUMPER) ON THE CIRCUIT BOARD MUST BE CUT IF OPTIONAL HUMIDISTAT IS USED. THE JUMPER MUST ALSO BE CUT WHEN APPLYING AN AIRFLOW COMMAND SIGNAL TO THE "BK" INPUT SUCH AS WITH THE VARIABLE SPEED SINGLE-ZONE AND MULTI-ZONE SYSTEM CONTROLLERS. ON SINGLE SPEED COOLING ONLY / NON-HEAT PUMP SYSTEMS, JUMPER "Y" TO "O" FOR PROPER OPERATION OF THE DELAY PROFILES AND THE HUMIDISTAT. FOR TWO COMPRESSOR OR TWO SPEED SYSTEMS, JUMPER "YLO" TO "O".
 - SEE INDOOR MOTOR AIRFLOW SELECTION CHART, LOCATED IN THE FURNACE FOR DIP SWITCH SETTINGS TO SET AIRFLOW AND COOLING OFF DELAYS.
 - POWER MUST BE OFF WHEN DIP SWITCHES ARE SET.
 - USED FOR *DH2B080A9V4V**, *DH2C100A9V4V** & *DH2D120A9V5V**.
 - ON POWER-UP, LAST FOUR FAULTS, IF ANY, WILL BE FLASHED ON RED LED. GREEN LED WILL BE SOLID ON DURING LAST FAULT RECOVERY.

DH2
REV 00

Field Wiring

FIELD WIRING DIAGRAM FOR SINGLE STAGE HEATING ONLY

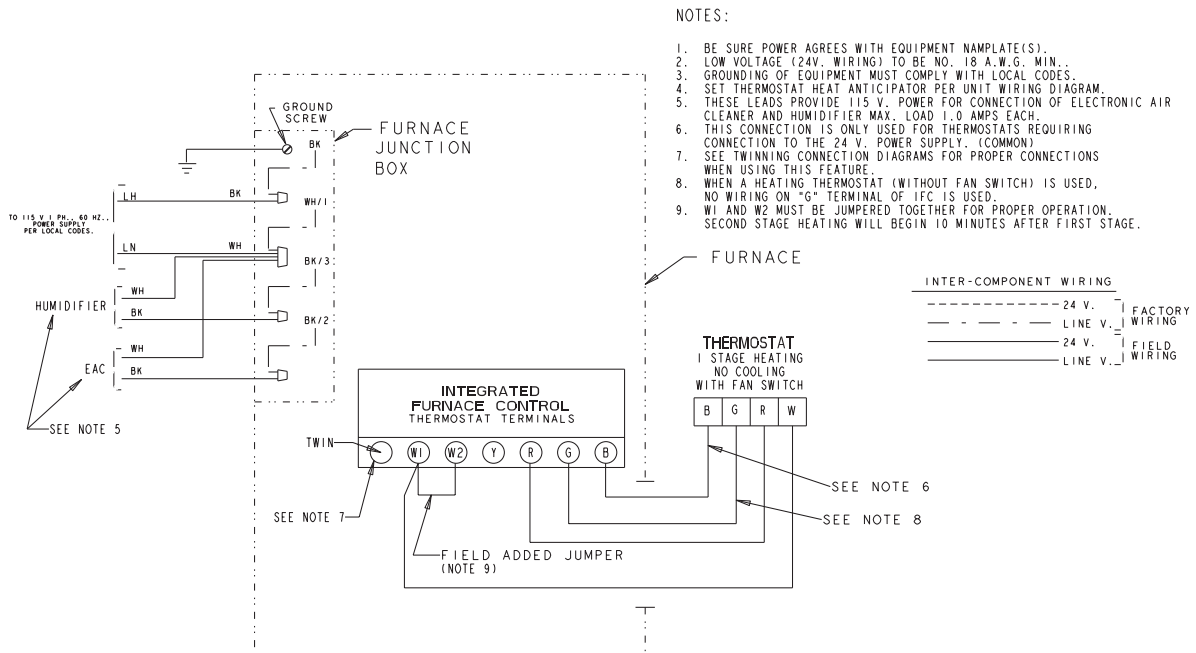

FIELD WIRING DIAGRAM FOR TWO STAGE HEATING ONLY

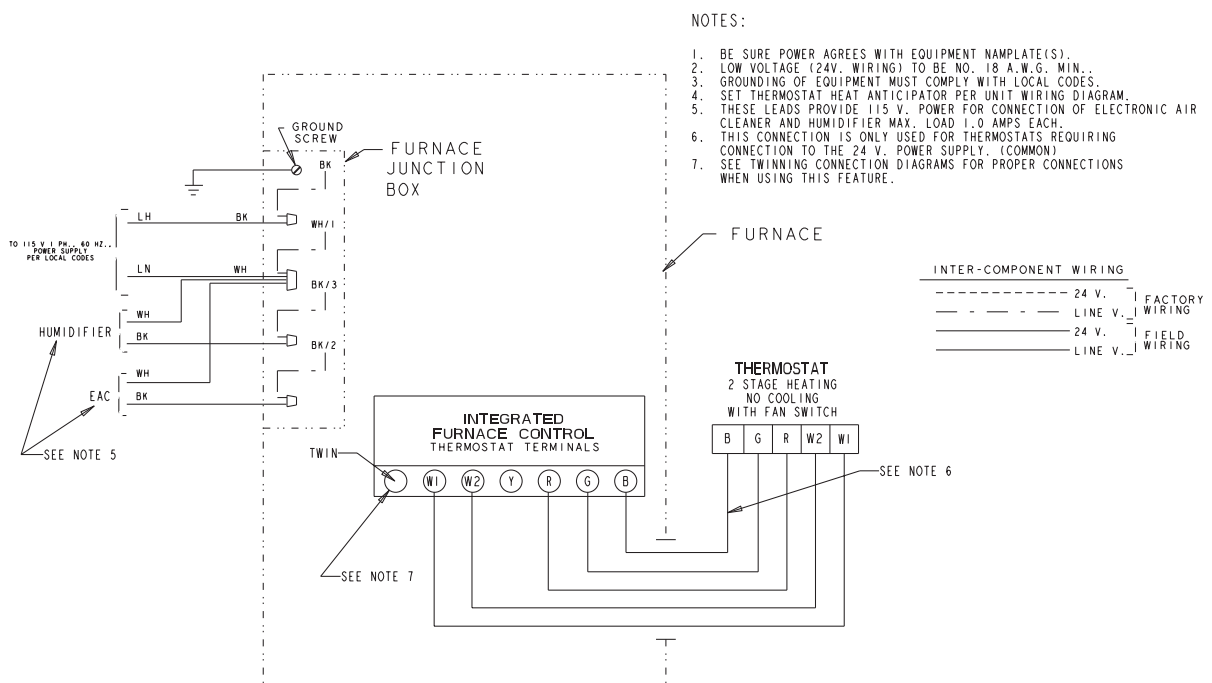

Field Wiring

FIELD WIRING DIAGRAM FOR SINGLE STAGE HEATING/COOLING (OUTDOOR SECTION WITHOUT TRANSFORMER)

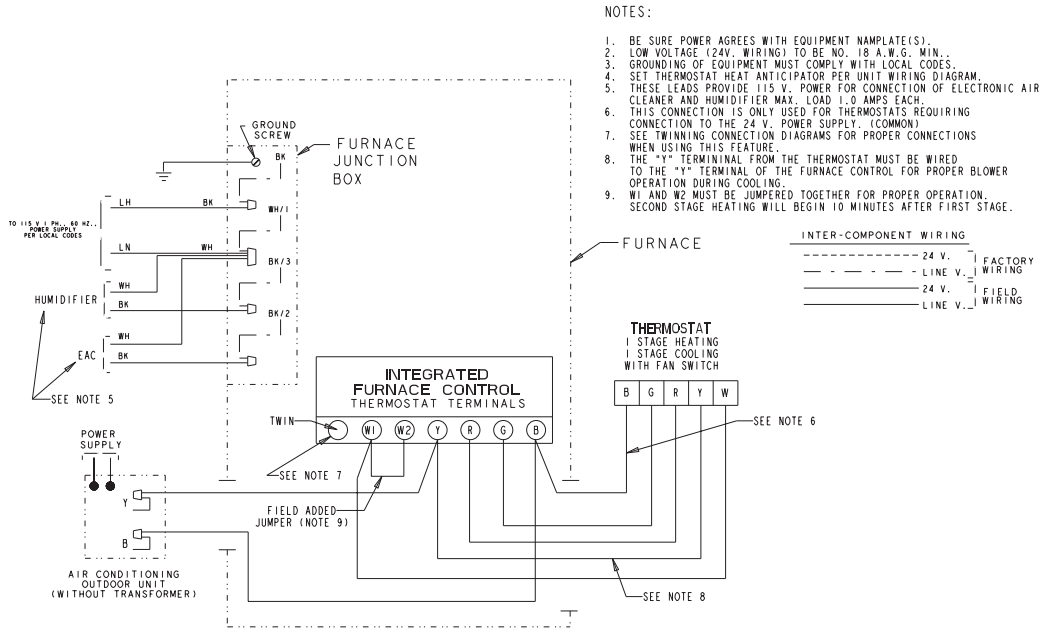

FIELD WIRING DIAGRAM FOR TWO STAGE HEATING/ SINGLE STAGE COOLING (OUTDOOR SECTION WITHOUT TRANSFORMER)

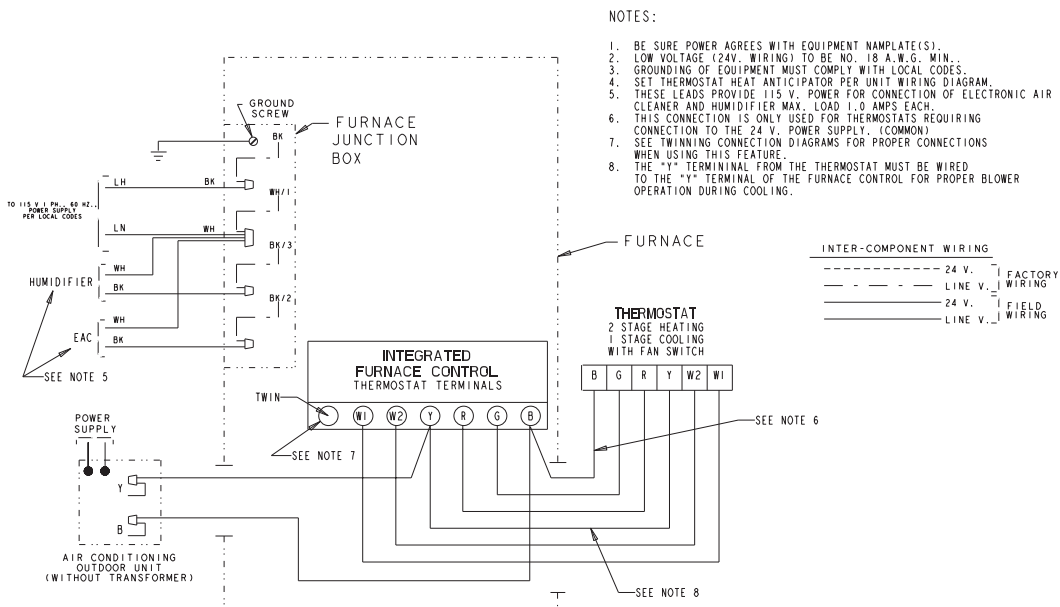

Dimensions

*UH2 UPFLOW/HORIZONTAL OUTLINE DRAWING (ALL DIMENSIONS ARE IN INCHES)

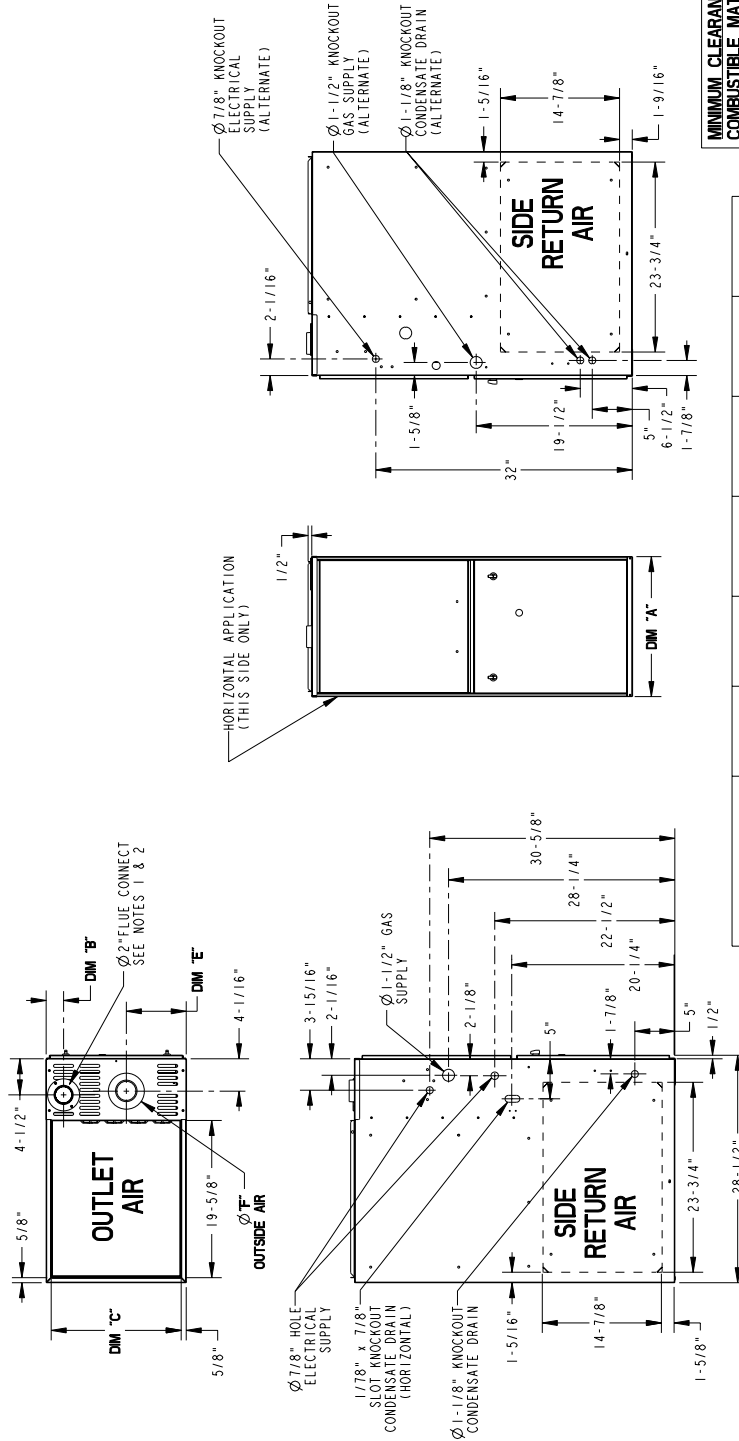

MINIMUM CLEARANCE TO COMBUSTIBLE MATERIALS

UPFLOWS	0 IN.
REAR	0 IN.
FRONT	3 IN.
TOP	1 IN.
FLUE	0 IN.

HORIZONTAL FLUE DISCHARGE ON THE LEFT

ALCOVE	STILES
RIGHT	0 IN.
LEFT	0 IN.
FRONT	6 IN.
FRONT	18 IN.
TOP	1 IN.
FLUE	0 IN.

CLOSET

STILES	RIGHT	LEFT	FRONT	FRONT	TOP	FLUE
RIGHT	1 IN.	1 IN.	3 IN.	3 IN.	1 IN.	0 IN.
LEFT	1 IN.	1 IN.	3 IN.	3 IN.	1 IN.	0 IN.
FRONT	1 IN.	1 IN.	3 IN.	3 IN.	1 IN.	0 IN.
FRONT	1 IN.	1 IN.	3 IN.	3 IN.	1 IN.	0 IN.
TOP	1 IN.	1 IN.	3 IN.	3 IN.	1 IN.	0 IN.
FLUE	1 IN.	1 IN.	3 IN.	3 IN.	1 IN.	0 IN.

MODEL (SEE NOTE 1 & 2)	DIM "A"	DIM "B"	DIM "C"	DIM "D"	DIM "E"	DIM "F"
*UH2B060A9V3V**	17-1/2"	2-1/4"	16-1/4"	16"	7-1/2"	2"
*UH2B080A9V3V**	21"	2-1/2"	19-3/4"	19-1/2"	9"	3"
*UH2C100A9V4V**	24-1/2"	2-15/16"	23-1/4"	23"	10"	3"

NOTES:
 1. *UH2C0960 REQUIRES 3" DIAMETER VENT PIPE.
 2. *UH2C0948 & *UH2C0960 REQUIRES 2-1/2" OR 3" DIAMETER VENT PIPE. VENT PIPE MAY BE LIMITED TO 2-1/2" OR 3" ON SOME MODELS AT DIFFERENT ALTITUDES. REFER TO THE VENT LENGTH TABLE FOR PROPER APPLICATION.

Dimensions

*DH2 DOWNFLOW/HORIZONTAL OUTLINE DRAWING (ALL DIMENSIONS ARE IN INCHES)

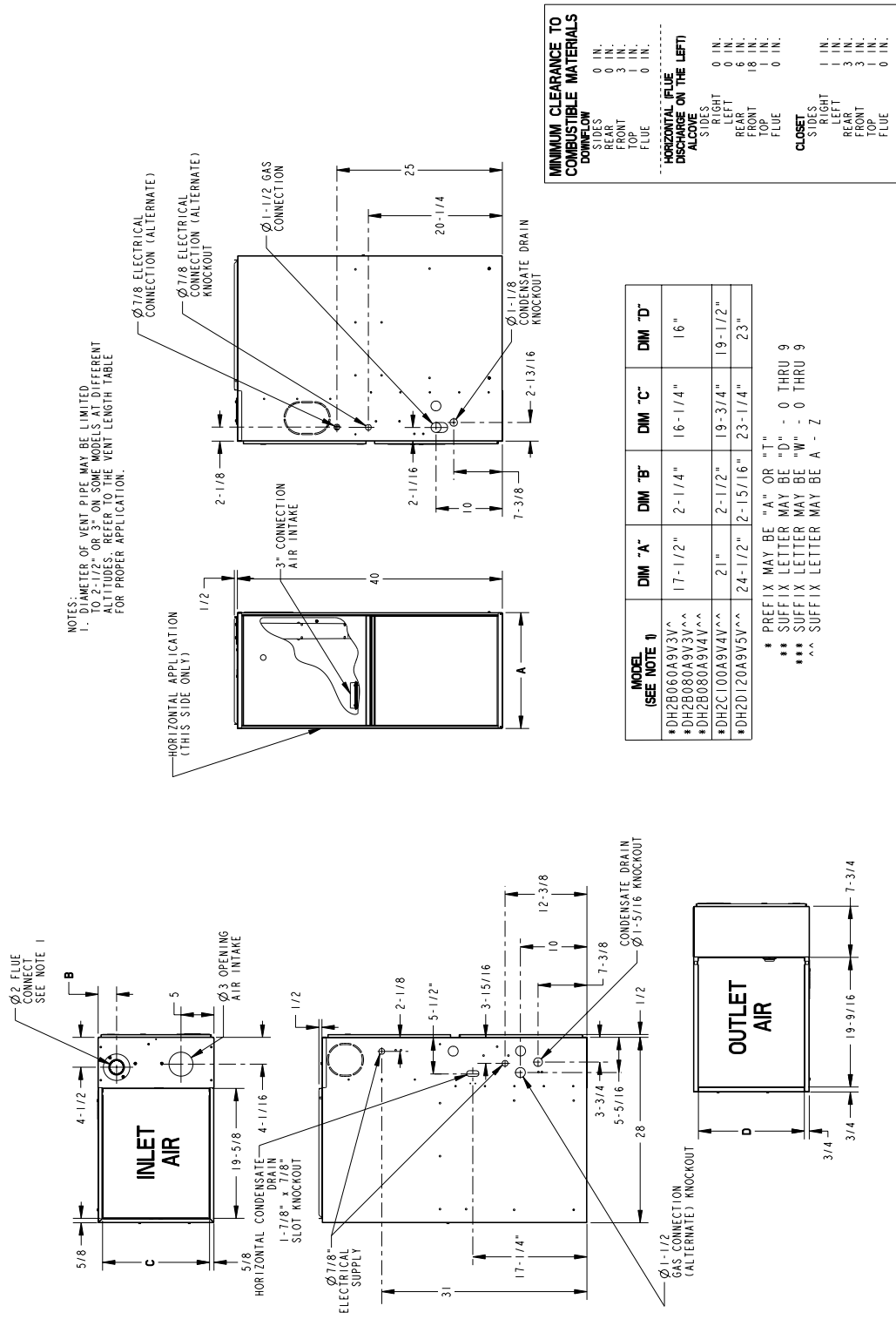

1. DIAMETER OF VENT PIPE MAY BE LIMITED TO 2-1/2" OR 3" ON SOME MODELS AT DIFFERENT TIMES. REFER TO THE VENT LENGTH TABLE FOR PROPER APPLICATION.

MODEL (SEE NOTE 1)	DIM "A"	DIM "B"	DIM "C"	DIM "D"
*DH2B060A9V3V ^{^^}	17-1/2"	2-1/4"	16-1/4"	16"
*DH2B080A9V3V ^{^^}	17-1/2"	2-1/4"	16-1/4"	16"
*DH2B080A9V4V ^{^^}	21"	2-1/2"	19-3/4"	19-1/2"
*DH2C100A9V4V ^{^^}	24-1/2"	2-15/16"	23-1/4"	23"
*DH2D120A9V5V ^{^^}	24-1/2"	2-15/16"	23-1/4"	23"

* PREFIX MAY BE "A" OR "T"
 ** SUFFIX LETTER MAY BE "D" - 0 THRU 9
 *** SUFFIX LETTER MAY BE "W" - 0 THRU 9
 ^^ SUFFIX LETTER MAY BE A - Z



Trane
6200 Troup Highway
Tyler, TX 75707
www.trane.com

Trane has a policy of continuous product and product data improvement and it reserves the right to change design and specifications without notice.

Free Manuals Download Website

<http://myh66.com>

<http://usermanuals.us>

<http://www.somanuals.com>

<http://www.4manuals.cc>

<http://www.manual-lib.com>

<http://www.404manual.com>

<http://www.luxmanual.com>

<http://aubethermostatmanual.com>

Golf course search by state

<http://golfingnear.com>

Email search by domain

<http://emailbydomain.com>

Auto manuals search

<http://auto.somanuals.com>

TV manuals search

<http://tv.somanuals.com>