



TRANE®

Installation Owner Diagnostics

Extra High Efficiency Water-Source Heat Pump Models WPVJ and WPHF



Models

"A" and later Design Sequence

WPVJ

018-072 — 60 HZ

WPHF

021-057 — 60 HZ

WSHP-SVX04A-EN



Notice

NOTICE:

Warnings and Cautions appear at appropriate sections throughout this manual. Read these carefully.

⚠ WARNING -Indicates a potentially hazardous situation which, if not avoided, could result in death or serious injury.

⚠ CAUTION -Indicates a potentially hazardous situation which, if not avoided, may result in minor or moderate injury. It may also be used to alert against unsafe practices.

CAUTION -Indicates a situation that may result in equipment or property-damage-only accidents.

Important!

Equipment is shipped FOB (Free on Board) at the manufacturer. Therefore, freight claims for damages against the carrier must be initiated by the receiver.

NOTICE:

Unit contains HCFC (R-22) Refrigerant

Instructions!

Section 608, Paragraph C of the 1990 Clean Air Act states:

Effective July 1, 1992, it shall be unlawful for any person, in course of maintaining, servicing, repairing, or disposing of an air conditioning system, to knowingly vent or release any CFC or HCFC refrigerant. Minimal releases (air purges or refrigerant hoses) associated with good faith attempts to recapture or recycle are exempt from the ban on venting.

Responsible Refrigerant Practices!

Trane believes that responsible refrigerant practices are important to the environment, our customers, and the air conditioning industry. All technicians who handle refrigerants must be certified. The Federal Clean Air Act (Section 608) sets forth the requirements for handling, reclaiming, recovering and recycling of certain refrigerants and the equipment that is used in these service procedures. In addition, some states or municipalities may have additional requirements that must also be adhered to for responsible management of refrigerants. Know the applicable laws and follow them.

Contents

Installation/Startup/Commissioning	4
Pre-installation Checklist	4
General Information	5
Dimensions/Weights	6
Installation Instructions	14
Electrical Requirements	20
Pre-Startup Checklist	25
Startup/Commissioning	26
Sequence of Operation	26
Operating Pressures	27
Startup Checklist & Log	30
Maintenance	31
Warranty Information	32
Troubleshooting Checklist	33
Unit Wiring	35

Pre-installation Checklist

WARNING **Fiberglass Wool!**

Product contains fiberglass wool. Disturbing the insulation in this product during installation, maintenance or repair will expose you to airborne particles of glass wool fibers and ceramic fibers known to the state of California to cause cancer through inhalation. Glass wool fibers may also cause respiratory, skin or eye irritation.

Jobsite Inspection

Always perform the following checks before accepting a unit:

1. Verify that the nameplate data matches the data on the sales order and bill of lading (including electrical data).
2. Verify that the power supply complies with the unit nameplate specifications.
3. Visually inspect the exterior of the unit, for signs of shipping damage. *Do not sign the bill of lading accepting the unit(s) until inspection has been completed. Check for damage promptly after the unit(s) are unloaded. Once the bill of lading is signed at the jobsite, the unit(s) are now the property of the SOLD TO party and future freight claims MAY NOT be accepted by the freight company.*
4. Verify that the refrigerant charge has been retained during shipment by use of gauges. Schrader taps are located external to the cabinet on the 1 1/2-ton through 6-ton equipment.
5. After assuring that charge has been retained, reinstall the schrader caps to assure that refrigerant leakage does not occur.

WARNING **Microbial Growth!**

Wet interior unit insulation can become an amplification site for microbial growth (mold), which may cause odors and damage to the equipment and building materials. If there is evidence of microbial growth (mold) on the interior insulation, the insulation should be removed and replaced prior to operating the system.

Jobsite Storage

This unit is intended for indoor use only. To protect the unit from damage due to the elements, and to prevent possible IAQ contaminant sources from growing, the unit should be stored indoors. If indoor storage is not possible, the following provisions for outdoor storage must be met:

1. Place the unit(s) on a dry surface or raise above the ground to assure adequate air circulation beneath the unit.
2. Cover the unit(s) with a water proof tarp to protect them from the elements.
3. Make provisions for continuous venting of the covered units to prevent moisture from standing on the unit(s) surfaces. Wet interior unit insulation can become an amplification site for microbial growth (mold) which has been determined to be a cause of odors and serious health related indoor air quality problems.
4. Store refrigeration units in the normal UP orientation to maintain oil in the compressor.
5. Model WPHF units should not be stacked more than three high. Do not stack WPVJ units.

General Information

Unit Nameplate

The unit nameplate is located at the front of the unit. It includes the unit model number, serial number, electrical characteristics, refrigerant charge, and other pertinent unit data.

Compressor Nameplate

The nameplate for the compressors are located on the compressor shell.

Unit Description

Before shipment, each unit is leak tested, dehydrated, charged with refrigerant and run tested for proper control operation.

Water-to-Refrigerant Coils

The co-axial water-to-refrigerant heat exchanger for the 1 1/2-ton through 6-ton equipment is constructed of copper or cupro-nickel (option) for the water section and stainless steel for the refrigeration section.

The heat exchanger is leak tested to assure there is no cross leakage between the water and refrigerant gas.

Water Connections

Water connections are located at the unit front for both the WPVJ and WPHF units. They are clearly labeled for supply/return connection. Sizes are as follows.

Dia.	Type
3/4"	WPHF 021-027 - Water in/out
1"	WPHF 030-072 - Water in/out
1"	WPVJ - Water in/out
3/4"	Drain
1/2"	Desuperheater

Blower/Motor

The blower and motor is located inside the unit cabinet. The motor may be easily removed for service through the equipment blower access panel.

Controls

The *control system* offered to control the unit is a Basic 24 volt control, Basic 24 volt control, or Tracer™ ZN510 control. A 50 VA transformer is factory supplied on the Basic 24V control configurations. A 75 VA transformer is fac-

tory supplied on the ZN510 (digital) control configurations.

ZN510 Controls

(WPVJ and WPHF option)

Units incorporating the ZN510 control option design will include a digital LonTalk™ certified control board. The control board will support such options as: random start delay, heating/cooling status, occupied/unoccupied mode and fan/filter status.

Power wiring is made at the contactor. See manual WSHP-IOP-2 for diagnostic information.

Schrader Connections

Connections for the low and high side of the refrigeration system are located conveniently at the equipments front panel. Sheet metal removal is not required for positive connection to the high and low schrader connections.

Dimensions/Weights/ Clearance

Table 1: Unit weights

Size	Shipping Weight with pallet (lb)	Shipping Weight w/o pallet (lb)
WPVJ		
018	249	239
024	250	240
030	298	288
036	315	305
042	324	314
048	398	388
060	439	429
072	440	430
WPHF		
021, 027	279	267
035, 040	367	356
047, 057	433	403

⚠ WARNING **Improper Unit Lift!**

Test lift unit approximately 24 inches to verify proper center of gravity lift point. To avoid dropping of unit, reposition lifting point if unit is not level. Failure to properly lift unit could result in death or serious injury or possible equipment or property-only damage.

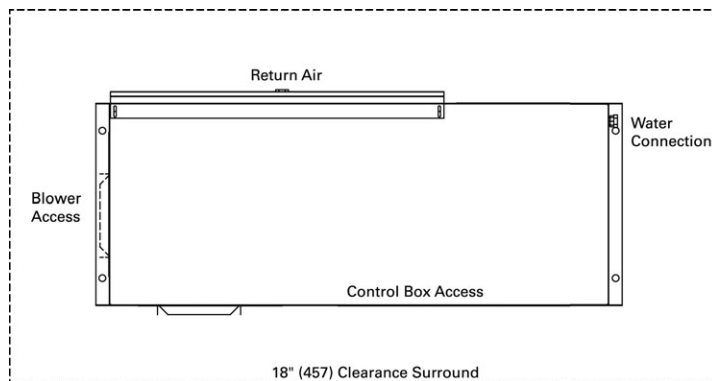

Figure 1: Mechanical clearances - WPHF

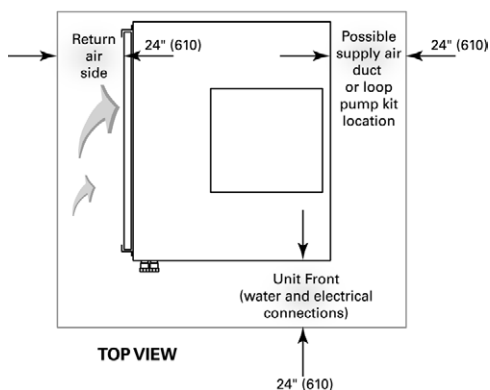

Figure 2: Mechanical clearances - WPVJ

Unit Location and Clearances

Locate the unit in an indoor area. The ambient temperature surrounding the unit must not be less than 45°F. Do not locate the unit in areas subject to freezing.

Attention should be given to service clearance and technician safety. The unit should be easily maintained or serviced in all applications. There must be enough space for service personnel to perform maintenance or repair. Provide sufficient room to make water, and electrical connection(s). Local and national codes should be followed in providing electrical power connections. See Figure 1 and 2 for mechanical clearances.

Dimensions

WPHF 021-057

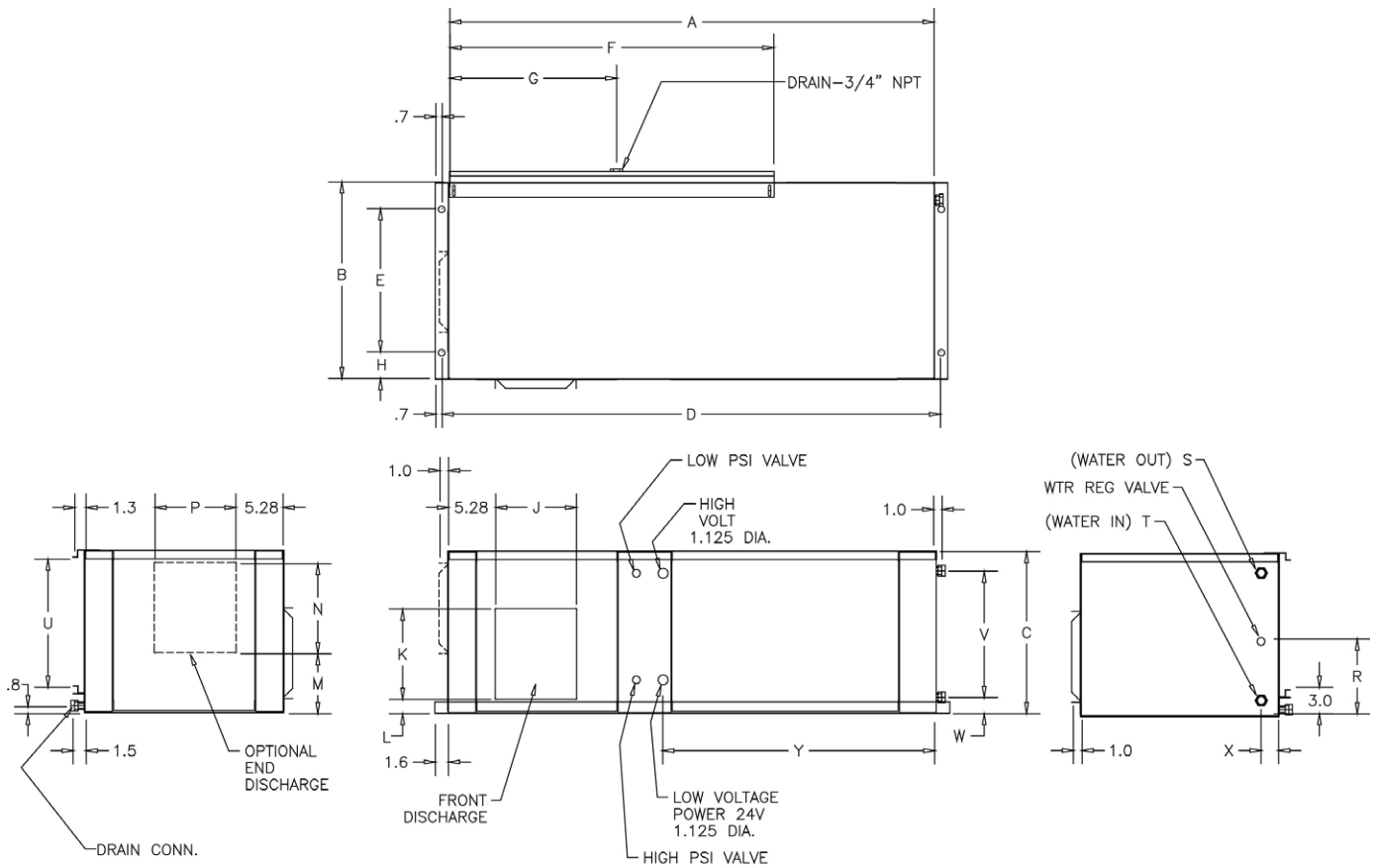

UNIT SIZE	A	B	C	D	E	F	G	H	J	K	L
21.0-27.0	44.25	22.25	18.33	46.00	16.16	26.25	13.75	3.00	8.18	10.18	1.62
35.0-40.0	54.50	22.25	18.33	56.25	16.16	36.55	18.80	3.00	9.12	10.18	1.62
47.0-57.0	61.00	25.50	20.75	62.75	19.88	43.80	22.43	2.88	13.13	11.38	1.82

UNIT SIZE	M	N	P	R	S	T	U	V	W	X	Y
21.0-27.0	6.75	10.18	8.18	8.37	.75 FPT	.75 FPT	14.55	12.94	2.00	2.06	20.25
35.0-40.0	6.75	10.18	9.12	8.37	1.0 FPT	1.0 FPT	14.55	14.25	1.82	1.98	30.60
47.0-57.0	7.81	11.38	13.13	9.75	1.0 FPT	1.0 FPT	16.50	14.87	2.30	1.37	33.75

Dimensions

WPVJ 018-024 LH

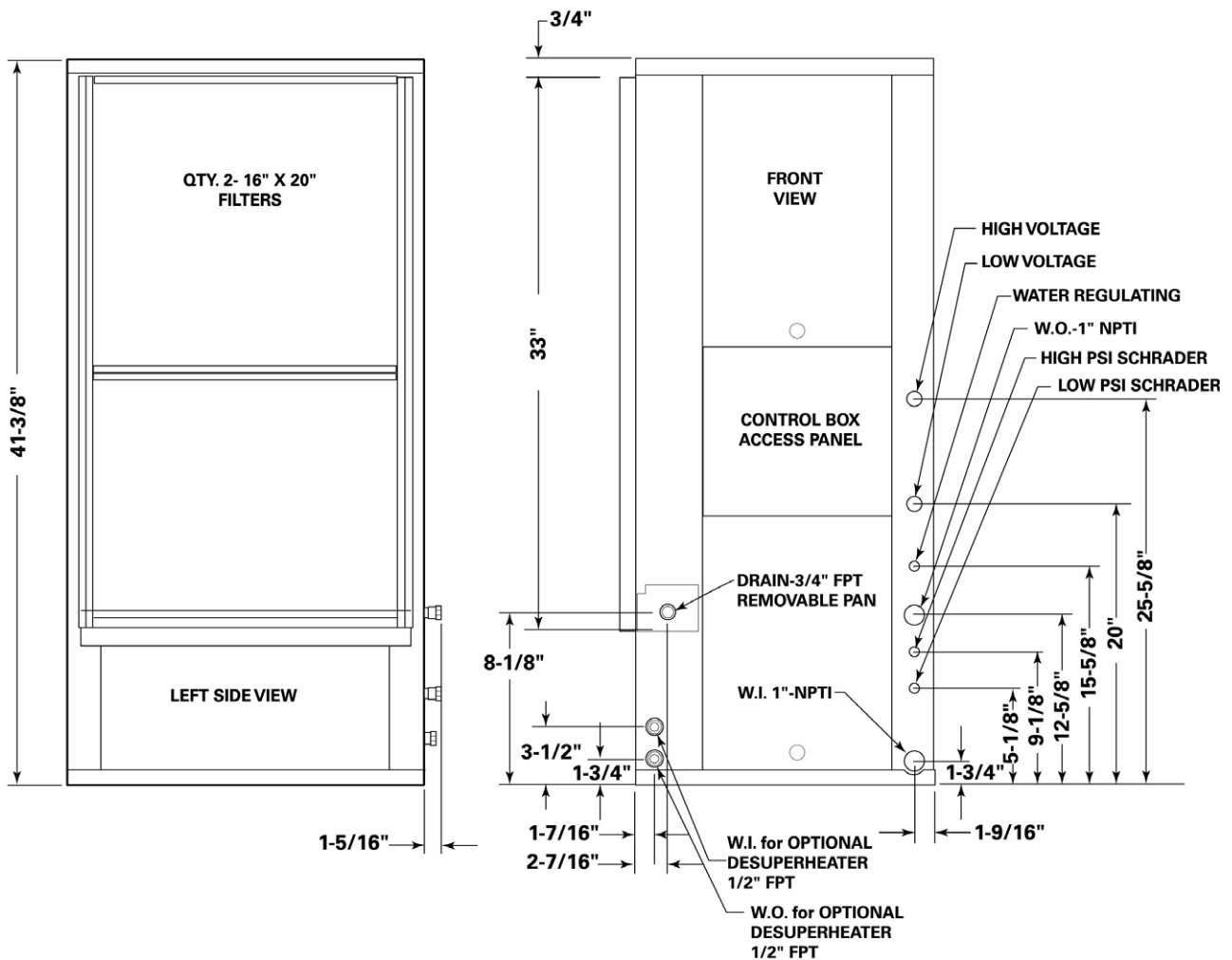
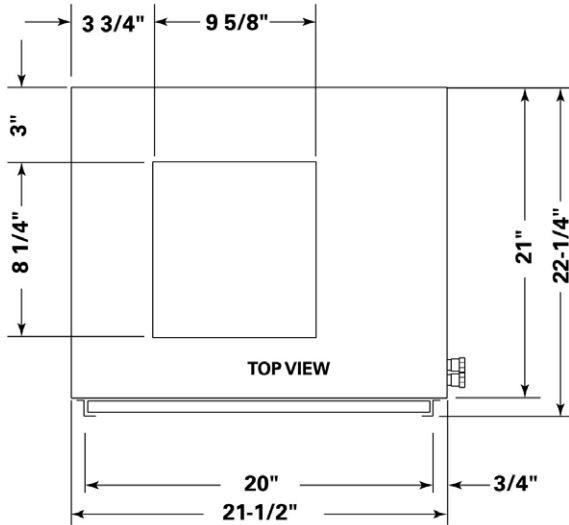

Dimensions

WPVJ 018-024 RH

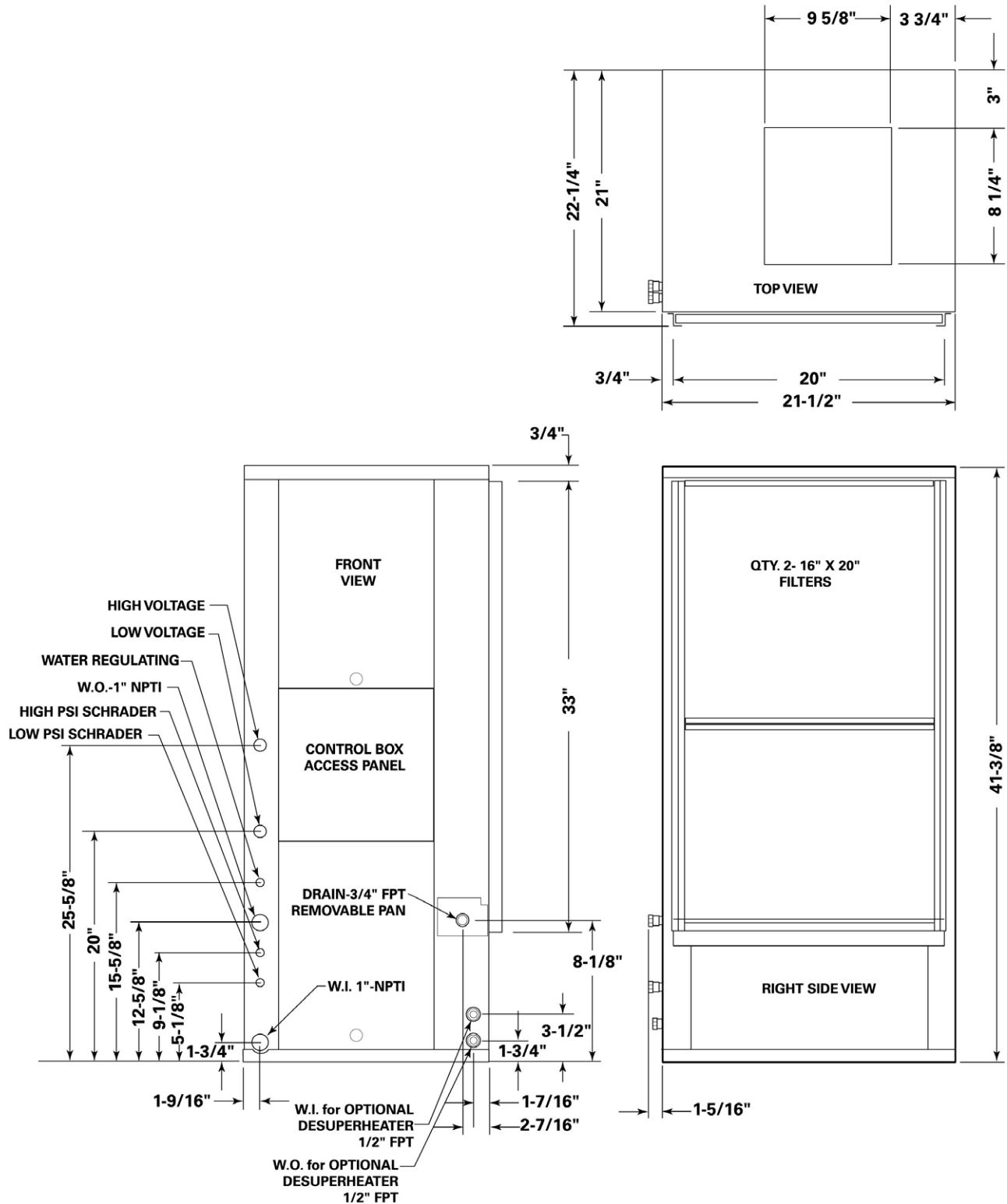

Dimensions

WPVJ 030-042 LH

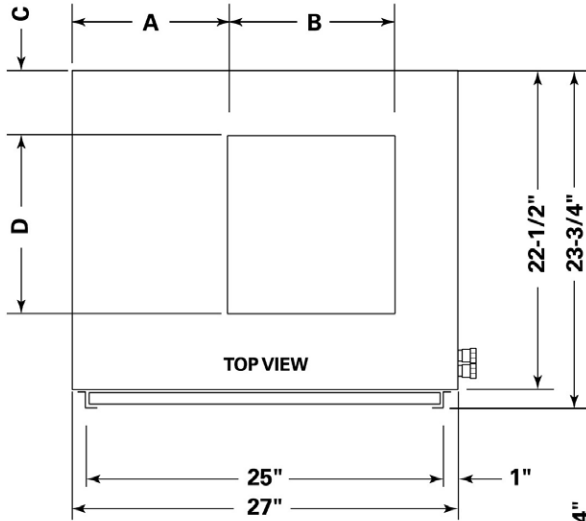

WPVJ with Standard Static MOTOR				
UNIT SIZE	A	B	C	D
030	10-1/2"	10-1/4"	4-1/4"	8-1/4"
036	10-1/2"	10-1/4"	3-1/8"	10-1/2"
042	10-1/2"	10-1/4"	3-1/8"	10-1/2"

WPVJ with High Static MOTOR				
UNIT SIZE	A	B	C	D
030	10"	11-3/8"	4-1/4"	8-1/4"
036	10"	11-3/8"	3-1/8"	10-1/2"
042	10"	11-3/8"	4-1/4"	8-1/4"

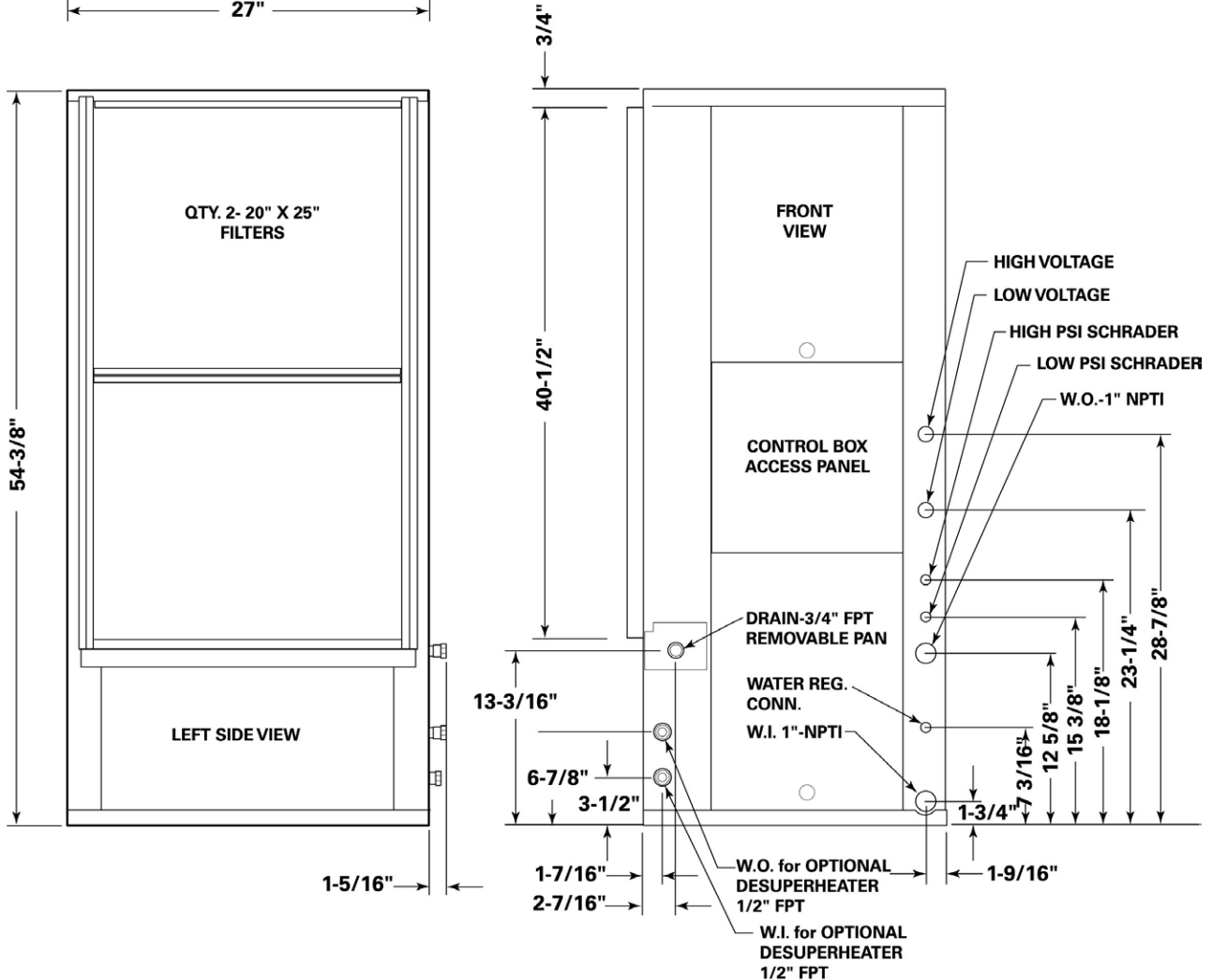

Dimensions

WPVJ 030-042 RH

WPVJ with Standard Static MOTOR				
UNIT SIZE	A	B	C	D
030	10-1/2"	10-1/4"	4-1/4"	8-1/4"
036	10-1/2"	10-1/4"	3-1/8"	10-1/2"
042	10-1/2"	10-1/4"	3-1/8"	10-1/2"

WPVJ with High Static MOTOR				
UNIT SIZE	A	B	C	D
030	10"	11-3/8"	4-1/4"	8-1/4"
036	10"	11-3/8"	3-1/8"	10-1/2"
042	10"	11-3/8"	4-1/4"	8-1/4"

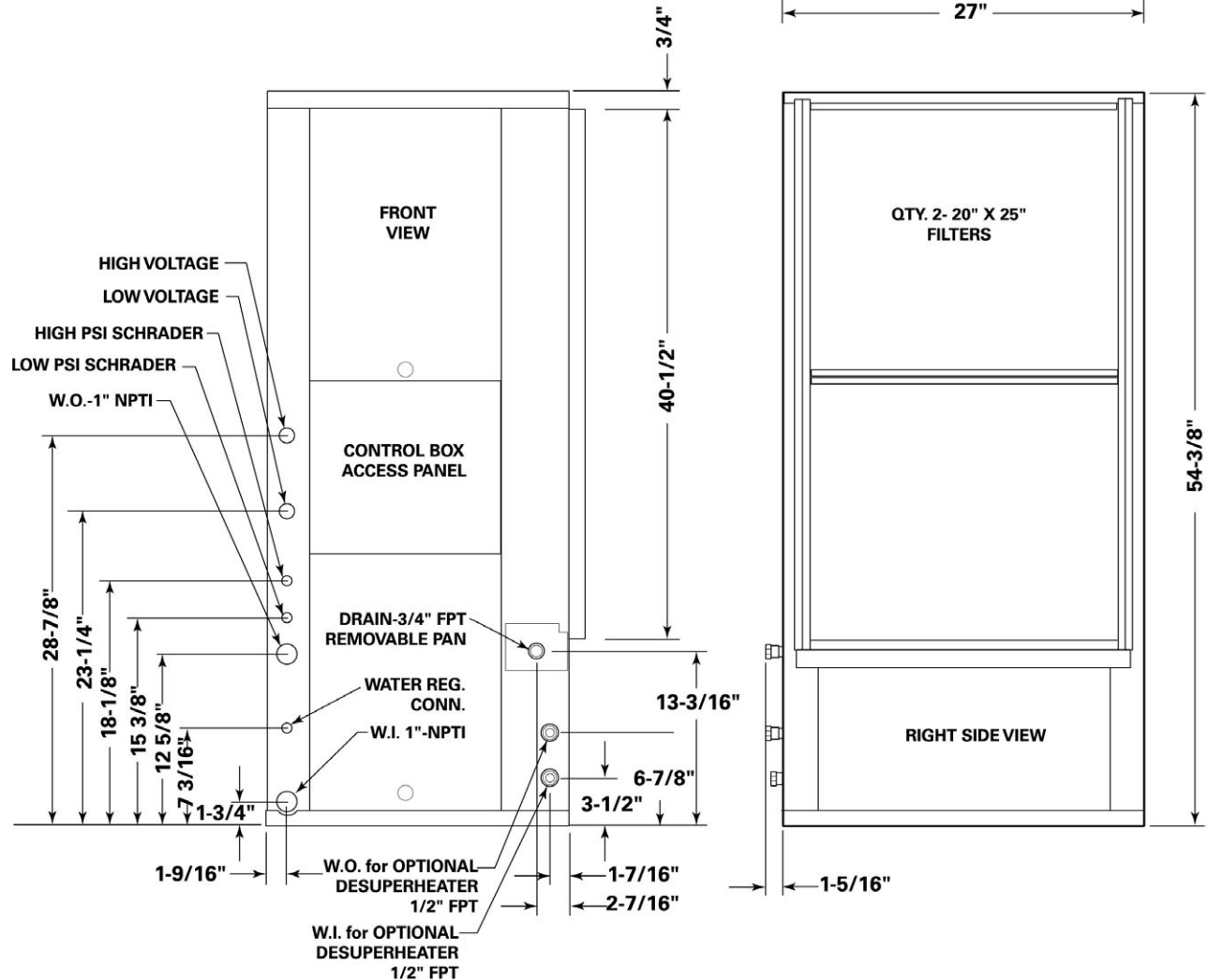
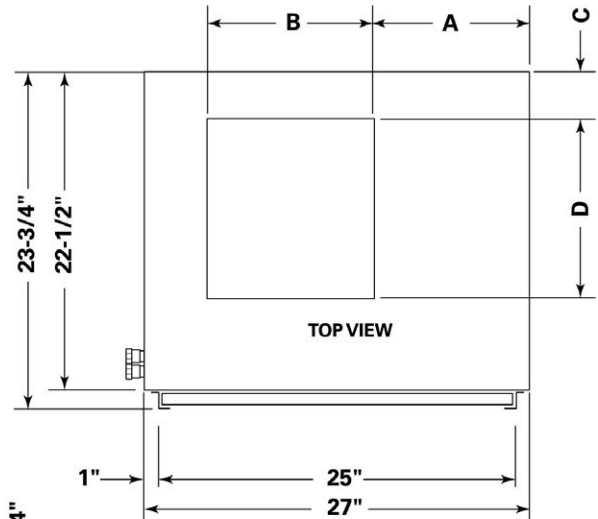



Dimensions

WPVJ 048-072 LH

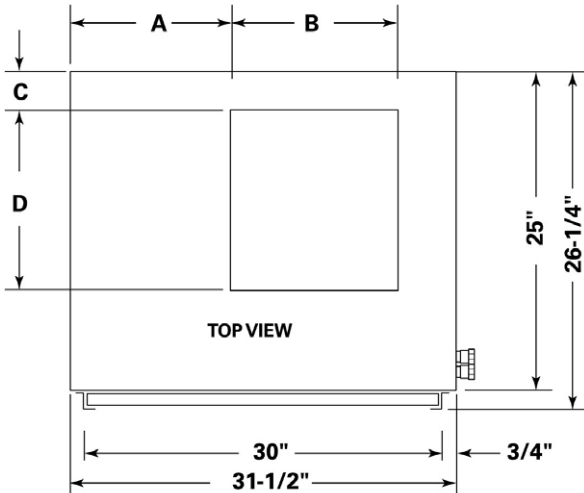

WPVJ with Standard Static MOTOR				
UNIT SIZE	A	B	C	D
048	11-5/8"	8-1/4"	2-5/8"	11-3/8"
060	9-1/4"	13-1/8"	2-5/8"	11-3/8"
072	9-1/4"	13-1/8"	2-5/8"	11-3/8"

WPVJ with High Static MOTOR				
UNIT SIZE	A	B	C	D
048	9-1/4"	13-1/8"	2-5/8"	11-3/8"
060	9-1/4"	13-1/8"	2-5/8"	13-1/2"
072	9-1/4"	13-1/8"	2-5/8"	13-1/2"

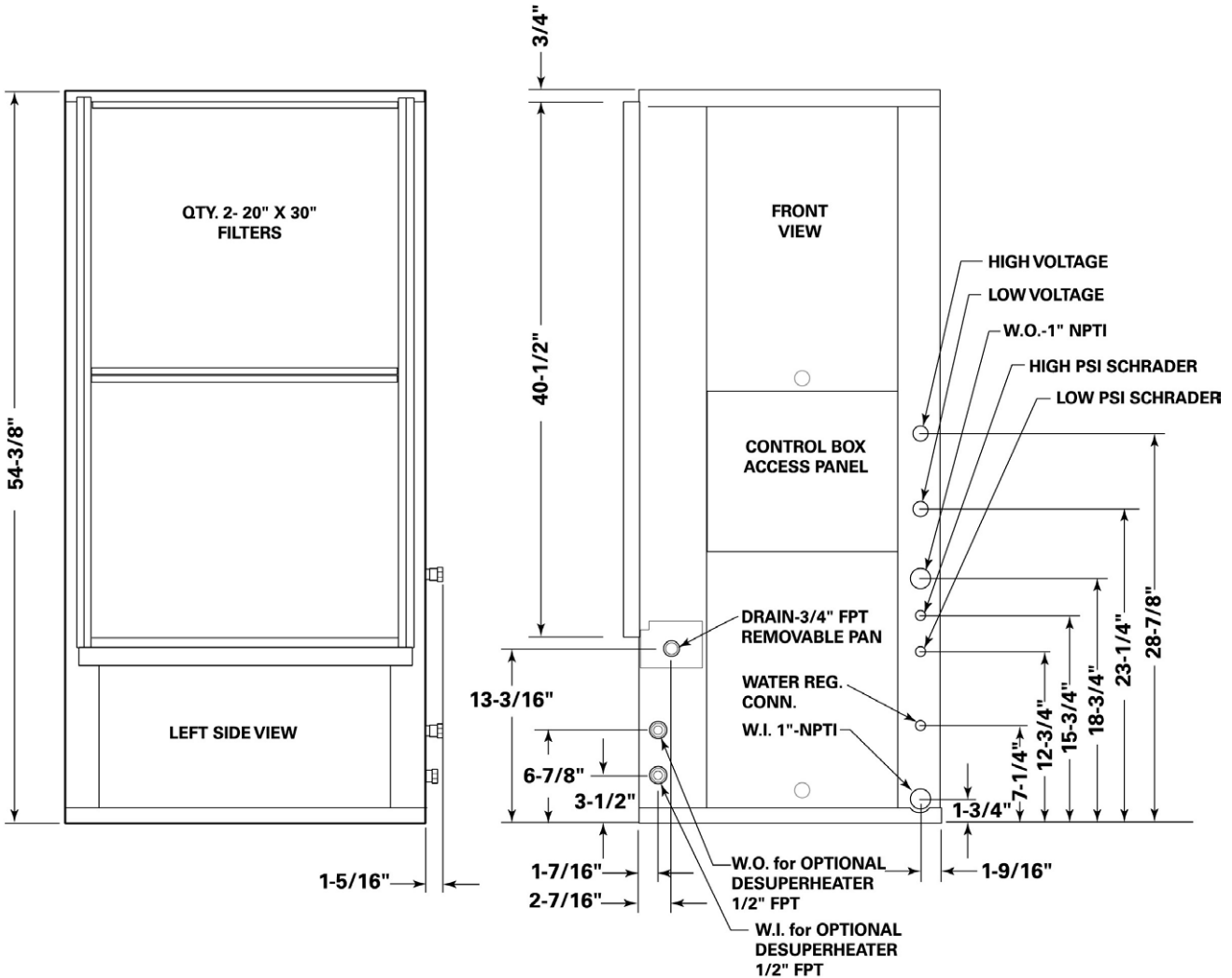

Dimensions

WPVJ 048-072 RH

WPVJ with Standard Static MOTOR				
UNIT SIZE	A	B	C	D
048	11-5/8"	8-1/4"	2-5/8"	11-3/8"
060	9-1/4"	13-1/8"	2-5/8"	11-3/8"
072	9-1/4"	13-1/8"	2-5/8"	11-3/8"

WPVJ with High Static MOTOR				
UNIT SIZE	A	B	C	D
048	9-1/4"	13-1/8"	2-5/8"	11-3/8"
060	9-1/4"	13-1/8"	2-5/8"	13-1/2"
072	9-1/4"	13-1/8"	2-5/8"	13-1/2"

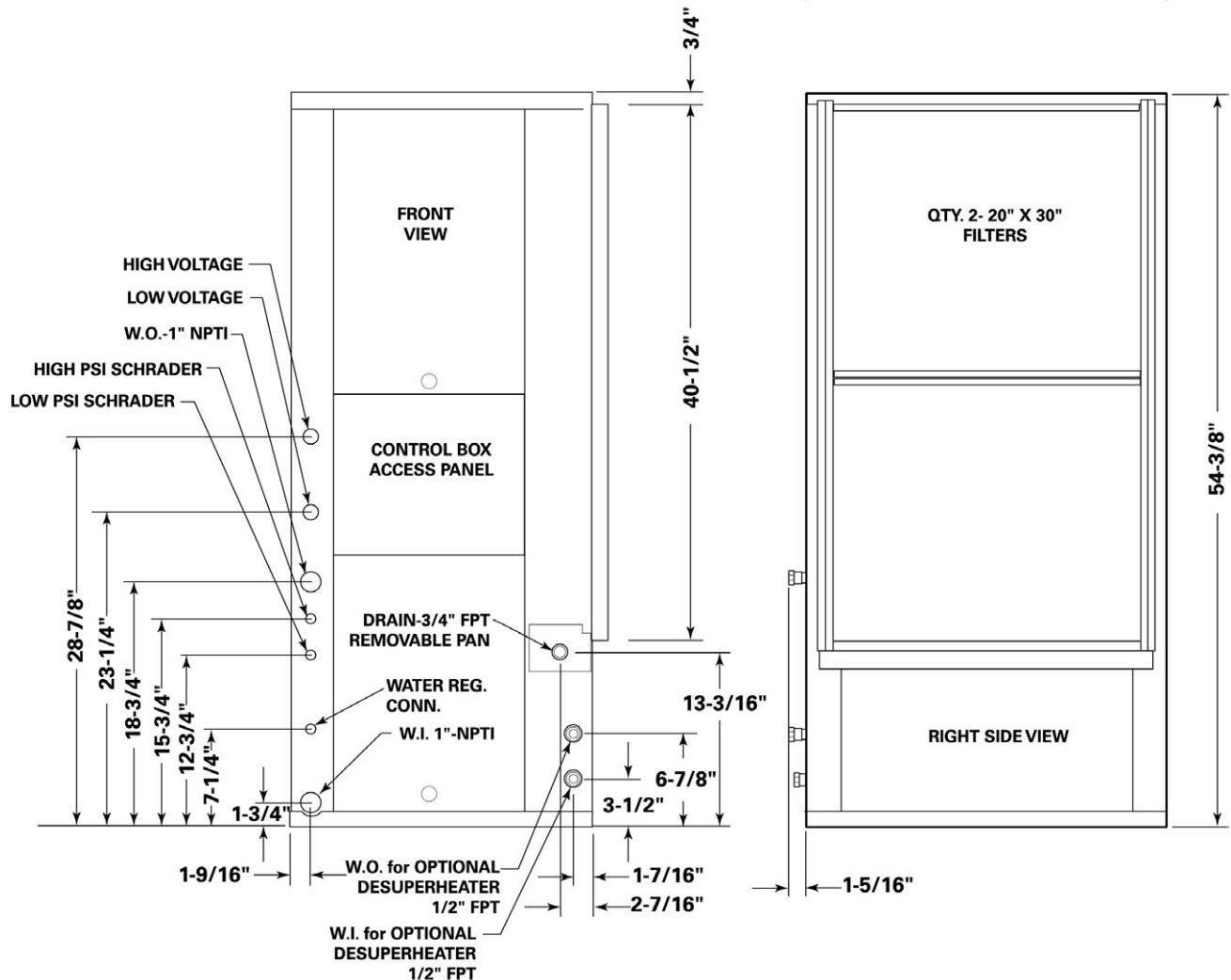
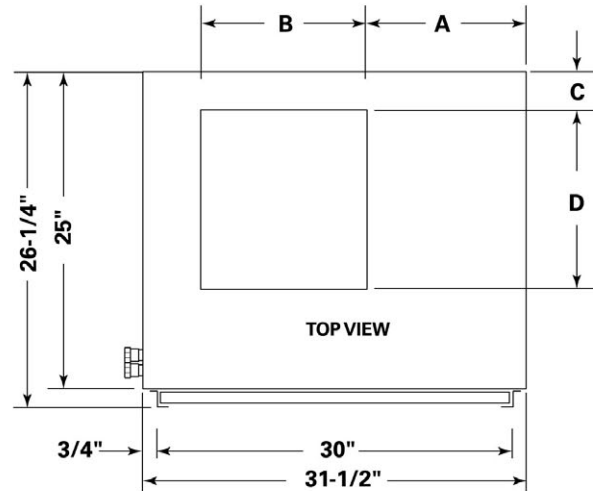

Installation

General Installation Checks

The checklist below is a summary of the steps required to successfully install a unit. This checklist is intended to acquaint the installing personnel with procedures required in the installation process. It does not replace the detailed instructions called out in the applicable sections of this manual.

- 1 Remove packaging and inspect the unit. Check the unit for shipping damage and material shortage; file a freight claim and notify appropriate sales representation.

Note: The vertical units have been tied to the skid by (8) shipping brackets with (16) 5/16" screws. Remove the (8) screws attached on the unit side, and (2) screws attached at the L bracket side. The unit may now be slid off of the skid. Re-attach (8) of the screws into the unit base pan.

- 2 Verify the correct model, options and voltage from the unit nameplate.
- 3 Verify the installation location of the unit will provide the required clearance for proper operation.
- 4 Remove refrigeration access panel and inspect the unit. Be certain the refrigerant tubing has clearance from adjacent parts.

⚠ WARNING **Hazardous Voltage!**

Disconnect all electric power, including remote disconnects before servicing. Follow proper lockout/tagout procedures to ensure the power can not be inadvertently energized. Failure to disconnect power before servicing could result in death or serious injury.

Main Electrical

- 5 Verify the power supply complies with the unit nameplate specifications.
- 6 Inspect all control panel components; tighten any loose connections.
- 7 Connect properly sized and protected power supply wiring to a field-supplied/installed disconnect switch and to the unit contactor (1K1) in the unit's cabinet control box for equipment.
- 8 Install proper grounding wires to an earth ground.

Note: All field-installed wiring must comply with NEC and applicable local codes.

Low Voltage Wiring (AC & DC) Requirements

- 9 Connect properly sized control wiring to the proper termination points between the thermostat/sensor and the terminal board in the unit's control box.

Filter Installation

- 10 Each unit ships with 1" filters. *Do not operate the unit without filters.*

Installation

Unit Installation; WPVJ

Duct collars are provided for the WPVJ equipment. The duct system and diffusers should be sized in accordance with ASHRAE or ACCA Manual D.

- 1 Install a flexible connector (field provided) for supply/return air duct connections on all metal duct systems.

Note: If the unit is connected to existing ductwork, an initial check of the mechanical system should be made to insure the duct has the capacity to handle the air required for the unit application. If ducting is too small, as in the replacement of heating only systems, larger ductwork should be installed. All existing ductwork should be checked for leaks, and repairs should be made.

- 2 Insulate the field ductwork with a minimum of 1" duct insulation.

Note: Installing the unit to an uninsulated ductwork in an unconditioned space may adversely affect the unit's performance, as well as increase noise emissions into the space.

- 3 Install proper condensate trapping to the equipment. *The unit drain connection is 3/4" (19mm). When designing the condensate trap, it is important to consider the unit's draw-thru design requiring negative pressure trapping.*

In a properly trapping system, when condensate forms during normal operation, the water level in the trap rises until there is a constant flow (Figure 3). It is imperative to maintain water in the trap and not allow the trap to dry out during heating season. Keeping the trap primed at all times will enable the water to flow properly.

Condensate piping must be installed to allow the cleanable condensate

pan to be removed for cleaning. Minimum clearances for drain pan removal are 22" (sizes 018 and 024), 25" (sizes 030 and 042), and 27" (sizes 048 through 072).

- 4 Flush System. *See page 17 for system flushing.*

Water Connection

For vibration isolation, it is recommended that flexible steel braided hoses be installed instead of hard piping between the supply/return risers and the equipment.

Trane offers 4-types of hose kit variations:

- Stainless steel braided flexible hose with manual shut-off (ball) valves

- Stainless steel braided flexible hose with manual deluxe shut-off (ball) valves
- Stainless steel braided flexible hose with manual circuit-setter valve
- Stainless steel braided flexible hose with automatic balancing valve

Additional accessories, such as a strainer are recommended for use to eliminate contaminants from entering the co-axial water-to-refrigerant heat exchangers.

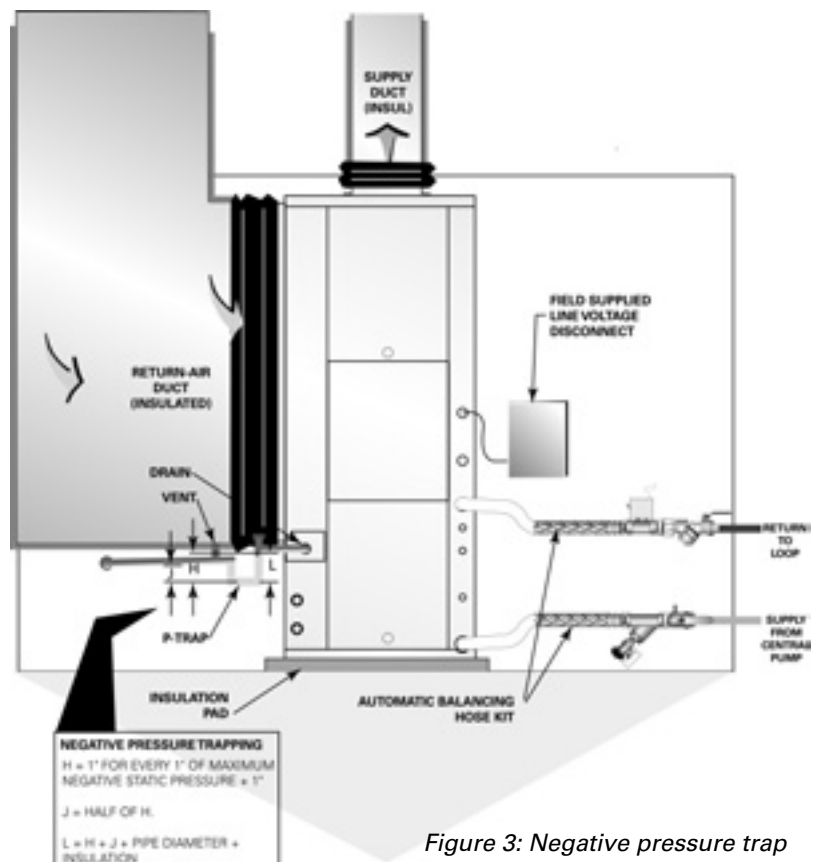

Figure 3: Negative pressure trap

Installation

Unit Installation; WPHF

Duct collars are provided for the WPHF equipment. The duct system and diffusers should be sized in accordance with ASHRAE or ACCA Manual D.

- 1 Install a flexible connector (field provided) for supply/return air duct connections on all metal duct systems.

Note: If the unit is connected to existing ductwork, an initial check of the mechanical system should be made to insure the duct has the capacity to handle the air required for the unit application. If ducting is too small, as in the replacement of heating only systems, larger ductwork should be installed. All existing ductwork should be checked for leaks, and repairs should be made.

- 2 Insulate the field ductwork with a minimum of 1" duct insulation.

Note: Installing the unit to an uninsulated ductwork in an unconditioned space may adversely affect the unit's performance, as well as increase noise emissions into the space.

- 3 Install proper condensate trapping to the equipment. *The unit drain connection is 3/4" (19mm). When designing the condensate trap, it is important to consider the unit's draw-thru design requiring negative pressure trapping.*

In a properly trapping system, when condensate forms during normal operation, the water level in the trap rises until there is a constant flow (Figure 4). It is imperative to maintain water in the trap and not allow the trap to dry out during heating season. Keeping the trap primed at all times will enable the water to flow properly.

Condensate piping must be installed to allow the cleanable condensate pan to be removed for cleaning.

- 4 Flush System. See page 17 for system flushing.

Water Connection

For vibration isolation, it is recommended that flexible steel braided hoses be installed instead of hard piping between the supply/return risers and the equipment.

Trane offers 4-types of hose kit variations:

- Stainless steel braided flexible hose with manual shut-off (ball) valves

- Stainless steel braided flexible hose with manual deluxe shut-off (ball) valves

- Stainless steel braided flexible hose with manual circuit-setter valve

- Stainless steel braided flexible hose with automatic balancing valve

Additional accessories, such as a strainer are recommended for use to eliminate contaminants from entering the co-axial water-to-refrigerant heat exchangers.

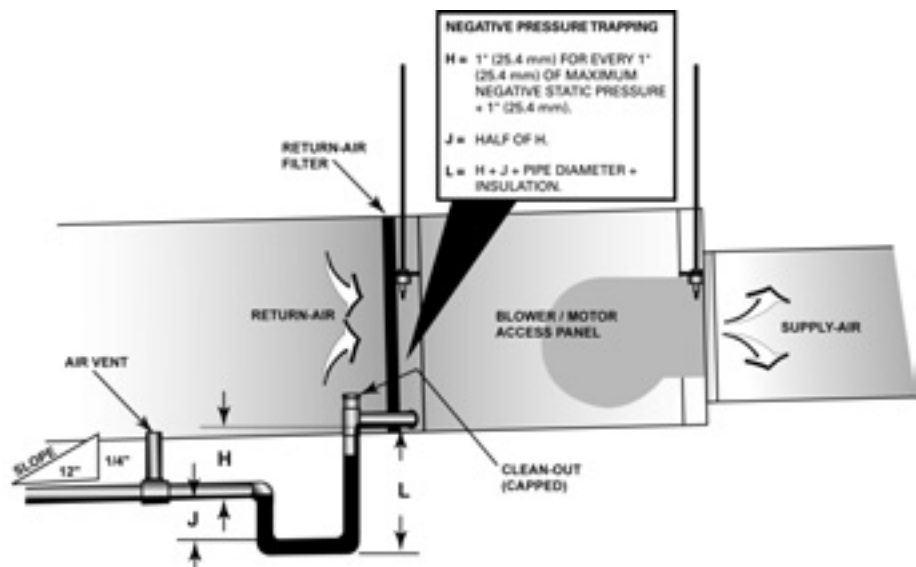

Figure 4: Negative pressure trap

Installation

Connecting a Distributed Pump Kit to a Closed Loop System

All piping external to the unit is the responsibility of the installer. The water pipe installation must be done in accordance with local codes. If no local code applies, national codes should be followed. It is the contractor's responsibility to know and adhere to all applicable codes.

Water inlet and outlet to the unit's water-to-refrigerant heat exchanger are clearly marked on the submittal drawings found on pages 7 through 13. The supply and return piping must be installed correctly to the unit to ensure the safety devices will work properly. Units that are not piped accordingly will not obtain the manufacturer's warranty.

A pump module and hose kit (Figure 5) may be used to connect the unit to closed loop piping.

Using Antifreeze

In areas of the country where entering water temperatures drop below 45°F or where piping is being run through areas subject to freezing, the loop must be freeze protected by using an approved antifreeze solution to prevent the earth loop water from freezing inside the heat exchanger.

Methanol, Ethylene, and Propylene Glycol are the most commonly used antifreeze solutions. Consult your geothermal unit supplier for the best solutions in your area.

Propylene glycol is not recommended in installations where the water temperature are expected to fall below 30°F. At extreme temperatures, the viscosity increases to the point where normal loop circulating pumps cannot maintain proper flow.

Calculate the approximate volume of water in the system by using the requirements detailed in Table 2. Add three gallons to this total to allow for the water contained in the hose kit and geothermal unit.

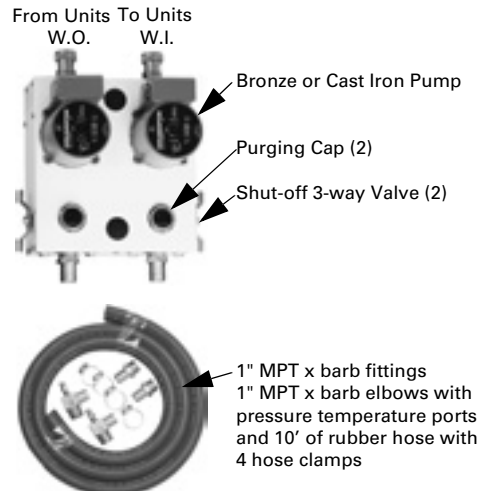

Figure 5: Pump module and hose kit

Table 2: Required Antifreeze by volume

Type of Antifreeze	Minimum Temperature for Freeze Protection				
	10°F	15°F	20°F	25°F	30°F
Methanol	25%	21%	16%	10%	3%
Propylene Glycol	23%	21%	19%	9%	6%
Ethylene Glycol	20%	19%	16%	14%	12%

Cleaning and Flushing the Water Loop

After the piping system is complete, cleaning and flushing the water loop should be done to avoid trash settle-out in the condenser (Figure 6). An extra pipe may be necessary to connect the hose kits.

- 1 Electrical power to the unit should be disconnected.
- 2 Double back the supply hose and connect directly to the return riser valve.
- 3 Fill the water system with clean water using the water make up connections. *Note: Air vents should be opened during filling.*
- 4 With the air vents closed, start the circulating pump and then crack the air vents to bleed off the trapped air, assuring circulation through all components of the system. *Note: Make up water must be available to the system to replace the volume formerly occupied by the air that is bled off.*

5 With the air vented and the water circulating, the entire system should be checked for leaks with repairs made as required.

6 Check and adjust the water/air level in the expansion tank.

7 Operate the boiler (if used) by raising the loop temperature to approximately 85°F. Make checks per manufacturer's instructions. During this operation, visual checks should be made for leaks that may have occurred due to increased heat. Repair as required.

8 Open the system at the lowest point for the initial blow down (making sure the make up water is equal to the water being dumped). Continue blow down until the water leaving the drain runs clear, but not less than 2 hours.

9 Shut down pumps and boiler (if used). Reconnect the hoses to the proper supply/return for each unit, placing the water-to-refrigerant heat exchanger in the water circulating system. *Note: Vents should be open when the pumps and boiler are shut down.*

10 Refill the system and bleed off any air. Add antifreeze to the system in climates where ambient temperature falls below freezing, using the proportion of antifreeze shown in Table 2.

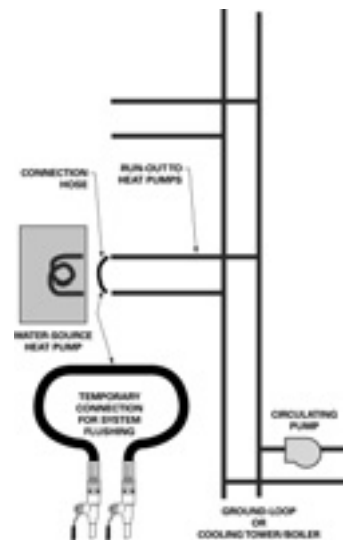

Figure 6: System flushing



Installation

Field Installed Power Wiring

Power wiring to the equipment must conform to National and Local Electric Codes (NEC) by a professional electrician.

⚠ WARNING **Live Electrical Components!**

During installation, testing, servicing and troubleshooting of this product, it may be necessary to work with live electrical components. Have a qualified licensed electrician or other individual who has been properly trained in handling live electrical components perform these tasks. Failure to follow all electrical safety precautions when exposed to live electrical components could result in death or serious injury.

Verify that the power supply available is compatible with the unit's nameplate. Use only copper conductors to connect the power supply to the unit.

CAUTION **Use Copper Conductors Only!**

Unit terminals are not designed to accept other types of conductors. Failure to use copper conductors may result in equipment damage.

Main Unit Power Wiring

A field supplied disconnect switch must be installed at or near the unit in accordance with the National Electric Code (NEC latest edition).

Location of the applicable electric service entrance for HIGH (line voltage) may be found on the unit submittals (pages 7 to 13).

- 1 The high voltage connection is made at the 1K1 contactor inside of the unit control box. Refer to the

connection diagram that is shipped with the unit for specific termination points.

- 2 Provide proper grounding for the unit in accordance with the local and national codes.

Control Power Transformer

The 24-volt control power transformers are to be used only with the accessories called out in this manual. Transformers rated greater than 50 VA are equipped with internal circuit breakers. If a circuit breaker trips, turn OFF all power to the unit before attempting to reset it.

⚠ WARNING **Hazardous Voltage!**

Disconnect all electric power, including remote disconnects before servicing. Follow proper lockout/tagout procedures to ensure the power can not be inadvertently energized. Failure to disconnect power before servicing could result in death or serious injury.

The transformer is located in the unit's control box.

Installation

Low Voltage Wiring

Low Voltage Wiring for Field Provided Thermostats/Zone Sensors

Ensure that the AC control wiring between the controls and the unit's termination point does not exceed three (3) ohms/conductor for the length of the run.

Note: Resistance in excess of 3-ohms per conductor may cause component failure due to insufficient AC voltage supply.

Check all loads and conductors for grounds, shorts, and mis-wiring.

Use copper conductors unless otherwise specified.

Do not run the AC low voltage wiring in the same conduit with the high voltage power wiring.

Table 3: 24V AC conductors

Distance from unit to Control	Recommended Wire Size
000-460 feet	18 gauge
461-732 feet	16 gauge
733-1000 feet	14 gauge

Thermostat Location

Location of the room thermostat/zone sensor is an important element of effective room control.

Areas where the thermostat or zone sensor should not be located include : behind doors, or corners; Near hot or cold air ducts; Near radiant heat (heat emitted from appliances or the sun); Near concealed pipes or chimneys; On outside walls or other non conditioned surfaces; In airflows from adjacent zones or other units (Figure 7).



Figure 7: Thermostat/sensor location



Electrical Requirements

Table E1: WPVJ Electrical Performance (Standard Static Blower Option)

Model No.	Volts/Hz/Ph	Total FLA	Comp. RLA (ea)	Comp. LRA (ea)	No. of Compres.	Cmp MCC	Blower Motor FLA	Blower Motor HP	Fan Motor Num	Minimum Circuit Ampacity	Overcurrent Protective Device	Desup	Desup RLA
WPVJ018	208/60/1	10.1	9.30	47.0	1	13.0	0.80	1/8	1	12.4	20	No	0
WPVJ018	208/60/1	10.31	9.30	47.0	1	13.0	0.80	1/8	1	12.6	20	Yes	0.21
WPVJ018	220-240/50/1	9.81	8.60	39.0	1	12.0	1.00	1/5	1	12.0	20	No	0.21
WPVJ018	230/60/1	10.1	9.30	47.0	1	13.0	0.80	1/8	1	12.4	20	No	0
WPVJ018	230/60/1	10.31	9.30	47.0	1	13.0	0.80	1/8	1	12.6	20	Yes	0.21
WPVJ018	265/60/1	9.6	8.60	39.0	1	12.0	1.00	1/5	1	11.8	20	No	0
WPVJ018	265/60/1	9.81	8.60	39.0	1	12.0	1.00	1/5	1	12.0	20	Yes	0.21
WPVJ024	208/60/1	12.6	11.40	56.0	1	16.0	1.20	1/5	1	15.5	25	No	0
WPVJ024	208/60/1	12.81	11.40	56.0	1	16.0	1.20	1/5	1	15.7	25	Yes	0.21
WPVJ024	220-240/50/1	10.6	9.60	47.0	1	13.5	1.00	1/5	1	13.0	20	No	0
WPVJ024	230/60/1	12.6	11.40	56.0	1	16.0	1.20	1/5	1	15.5	25	No	0
WPVJ024	230/60/1	12.81	11.40	56.0	1	16.0	1.20	1/5	1	15.7	25	Yes	0.21
WPVJ024	265/60/1	10.81	9.60	47.0	1	13.5	1.00	1/5	1	13.2	20	Yes	0.21
WPVJ024	265/60/1	10.6	9.60	47.0	1	13.5	1.00	1/5	1	13.0	20	No	0
WPVJ030	208/60/1	15.1	13.60	67.0	1	19.0	1.50	1/4	1	18.5	30	No	0
WPVJ030	208/60/1	15.31	13.60	67.0	1	19.0	1.50	1/4	1	18.7	30	Yes	0.21
WPVJ030	220-240/50/1	13.4	12.10	58.0	1	17.0	1.30	1/4	1	16.4	25	No	0
WPVJ030	230/60/1	15.1	13.60	67.0	1	19.0	1.50	1/4	1	18.5	30	No	0
WPVJ030	230/60/1	15.31	13.60	67.0	1	19.0	1.50	1/4	1	18.7	30	Yes	0.21
WPVJ030	265/60/1	13.4	12.10	58.0	1	17.0	1.30	1/4	1	16.4	25	No	0
WPVJ030	265/60/1	13.61	12.10	58.0	1	17.0	1.30	1/4	1	16.6	25	Yes	0.21
WPVJ036	208/60/1	17.8	15.00	73.0	1	21.0	2.80	1/3	1	21.6	35	No	0
WPVJ036	208/60/1	18.01	15.00	73.0	1	21.0	2.80	1/3	1	21.8	35	Yes	0.21
WPVJ036	208/60/3	13.5	10.70	63.0	1	15.0	2.80	1/3	1	16.2	25	No	0
WPVJ036	208/60/3	13.71	10.70	63.0	1	15.0	2.80	1/3	1	16.4	25	Yes	0.21
WPVJ036	220-240/50/1	16.6	14.30	71.0	1	20.0	2.30	1/3	1	20.2	30	No	0
WPVJ036	230/60/1	17.8	15.00	73.0	1	21.0	2.80	1/3	1	21.6	35	No	0
WPVJ036	230/60/1	18.01	15.00	73.0	1	21.0	2.80	1/3	1	21.8	35	Yes	0.21
WPVJ036	230/60/3	13.5	10.70	63.0	1	15.0	2.80	1/3	1	16.2	25	No	0
WPVJ036	230/60/3	13.71	10.70	63.0	1	15.0	2.80	1/3	1	16.4	25	Yes	0.21
WPVJ036	265/60/1	16.6	14.30	71.0	1	20.0	2.30	1/3	1	20.2	30	No	0
WPVJ036	265/60/1	16.81	14.30	71.0	1	20.0	2.30	1/3	1	20.4	30	Yes	0.21
WPVJ036	380-415/50/3	6.1	5.00	31.0	1	7.0	1.10	1/3	1	7.4	15	No	0
WPVJ036	460/60/3	6.1	5.00	31.0	1	7.0	1.10	1/3	1	7.4	15	No	0
WPVJ036	460/60/3	6.31	5.00	31.0	1	7.0	1.10	1/3	1	7.6	15	Yes	0.21
WPVJ042	208/60/1	21.3	18.40	95.0	1	25.8	2.90	1/2	1	25.9	40	No	0
WPVJ042	208/60/1	21.51	18.40	95.0	1	25.8	2.90	1/2	1	26.1	40	Yes	0.21
WPVJ042	208/60/3	14.3	11.40	77.0	1	16.0	2.90	1/2	1	17.2	25	No	0
WPVJ042	208/60/3	14.51	11.40	77.0	1	16.0	2.90	1/2	1	17.4	25	Yes	0.21
WPVJ042	230/60/1	21.3	18.40	95.0	1	25.8	2.90	1/2	1	25.9	40	No	0
WPVJ042	230/60/1	21.51	18.40	95.0	1	25.8	2.90	1/2	1	26.1	40	Yes	0.21
WPVJ042	230/60/3	14.3	11.40	77.0	1	16.0	2.90	1/2	1	17.2	25	No	0
WPVJ042	230/60/3	14.51	11.40	77.0	1	16.0	2.90	1/2	1	17.4	25	Yes	0.21
WPVJ042	380-415/50/3	7.1	5.70	39.0	1	8.0	1.40	1/2	1	8.5	15	No	0
WPVJ042	460/60/3	7.1	5.70	39.0	1	8.0	1.40	1/2	1	8.5	15	No	0
WPVJ042	460/60/3	7.31	5.70	39.0	1	8.0	1.40	1/2	1	8.7	15	Yes	0.21

Electrical Requirements

Table E1: WPVJ Electrical Performance (Standard Static Blower Option-continued)

Model No.	Volts/Hz/Ph	Total FLA	Comp. RLA (ea)	Comp. LRA (ea)	No. of Compres.	Cmp MCC	Blower Motor FLA	Blower Motor HP	Fan Motor Num	Minimum Circuit Ampacity	Overcurrent Protective Device	Desup	Desup RLA
WPVJ048	208/60/1	23.3	20.40	109.0	1	28.6	2.90	1/2	1	28.4	45	No	0
WPVJ048	208/60/1	23.51	20.40	109.0	1	28.6	2.90	1/2	1	28.6	45	Yes	0.21
WPVJ048	208/60/3	16.8	13.90	88.0	1	19.4	2.90	1/2	1	20.3	30	No	0
WPVJ048	208/60/3	17.01	13.90	88.0	1	19.4	2.90	1/2	1	20.5	30	Yes	0.21
WPVJ048	230/60/1	23.3	20.40	109.0	1	28.6	2.90	1/2	1	28.4	45	No	0
WPVJ048	230/60/1	23.51	20.40	109.0	1	28.6	2.90	1/2	1	28.6	45	Yes	0.21
WPVJ048	230/60/3	16.8	13.90	88.0	1	19.4	2.90	1/2	1	20.3	30	No	0
WPVJ048	230/60/3	17.01	13.90	88.0	1	19.4	2.90	1/2	1	20.5	30	Yes	0.21
WPVJ048	380-415/50/3	8.5	7.10	44.0	1	10.0	1.40	1/2	1	10.3	15	No	0
WPVJ048	460/60/3	8.5	7.10	44.0	1	10.0	1.40	1/2	1	10.3	15	No	0
WPVJ048	460/60/3	8.71	7.10	44.0	1	10.0	1.40	1/2	1	10.5	15	Yes	0.21
WPVJ060	208/60/1	32.2	28.00	169.0	1	39.0	4.20	3/4	1	39.2	60	No	0
WPVJ060	208/60/1	32.41	28.00	169.0	1	39.0	4.20	3/4	1	39.4	60	Yes	0.21
WPVJ060	208/60/3	23.5	19.30	123.0	1	27.0	4.20	3/4	1	28.3	45	No	0
WPVJ060	208/60/3	23.71	19.30	123.0	1	27.0	4.20	3/4	1	28.5	45	Yes	0.21
WPVJ060	230/60/1	32.2	28.00	169.0	1	39.0	4.20	3/4	1	39.2	60	No	0
WPVJ060	230/60/1	32.41	28.00	169.0	1	39.0	4.20	3/4	1	39.4	60	Yes	0.21
WPVJ060	230/60/3	23.5	19.30	123.0	1	27.0	4.20	3/4	1	28.3	45	No	0
WPVJ060	230/60/3	23.71	19.30	123.0	1	27.0	4.20	3/4	1	28.5	45	Yes	0.21
WPVJ060	380-415/50/3	9.6	7.50	49.5	1	10.5	2.10	3/4	1	11.5	15	No	0
WPVJ060	460/60/3	9.6	7.50	49.5	1	10.5	2.10	3/4	1	11.5	15	No	0
WPVJ060	460/60/3	9.81	7.50	49.5	1	10.5	2.10	3/4	1	11.7	15	Yes	0.21
WPVJ060	575/60/3	8.1	6.40	40.0	1	9.0	1.70	3/4	1	9.7	15	No	0
WPVJ060	575/60/3	8.31	6.40	40.0	1	9.0	1.70	3/4	1	9.9	15	Yes	0.21
WPVJ072	208/60/1	36.3	32.10	169.0	1	45.0	4.20	3/4	1	44.3	70	No	0
WPVJ072	208/60/1	36.51	32.10	169.0	1	45.0	4.20	3/4	1	44.5	70	Yes	0.21
WPVJ072	208/60/3	23.5	19.30	137.0	1	27.0	4.20	3/4	1	28.3	45	No	0
WPVJ072	208/60/3	23.71	19.30	137.0	1	27.0	4.20	3/4	1	28.5	45	Yes	0.21
WPVJ072	230/60/1	36.3	32.10	169.0	1	45.0	4.20	3/4	1	44.3	70	No	0
WPVJ072	230/60/1	36.51	32.10	169.0	1	45.0	4.20	3/4	1	44.5	70	Yes	0.21
WPVJ072	230/60/3	23.5	19.30	137.0	1	27.0	4.20	3/4	1	28.3	45	No	0
WPVJ072	230/60/3	23.71	19.30	137.0	1	27.0	4.20	3/4	1	28.5	45	Yes	0.21
WPVJ072	380-415/50/3	12.1	10.00	62.0	1	14.0	2.10	3/4	1	14.6	25	No	0
WPVJ072	460/60/3	12.1	10.00	62.0	1	14.0	2.10	3/4	1	14.6	25	No	0
WPVJ072	460/60/3	12.31	10.00	62.0	1	14.0	2.10	3/4	1	14.8	25	Yes	0.21
WPVJ072	575/60/3	9.6	7.90	50.0	1	11.0	1.70	3/4	1	11.6	15	No	0
WPVJ072	575/60/3	9.81	7.90	50.0	1	11.0	1.70	3/4	1	11.8	15	Yes	0.21

Table E2: WPVJ Electrical Performance (High Static Blower Option)

Model No.	Volts/Hz/Ph	Total FLA	Comp. RLA (ea)	Comp. LRA (ea)	No. of Compres.	Cmp MCC	Blower Motor FLA	Blower Motor HP	Fan Motor Num	Minimum Circuit Ampacity	Overcurrent Protective Device	Desup	Desup RLA
WPVJ018	208/60/1	10.5	9.30	47.0	1	13.0	1.20	1/5	1	12.8	20	No	0
WPVJ018	208/60/1	10.71	9.30	47.0	1	13.0	1.20	1/5	1	13.0	20	Yes	0.21
WPVJ018	220-240/50/1	9.6	8.60	39.0	1	12.0	1.00	1/5	1	11.8	20	No	0
WPVJ018	230/60/1	10.5	9.30	47.0	1	13.0	1.20	1/5	1	12.8	20	No	0
WPVJ018	230/60/1	10.71	9.30	47.0	1	13.0	1.20	1/5	1	13.0	20	Yes	0.21
WPVJ018	265/60/1	9.6	8.60	39.0	1	12.0	1.00	1/5	1	11.8	20	No	0
WPVJ018	265/60/1	9.81	8.60	39.0	1	12.0	1.00	1/5	1	12.0	20	Yes	0.21



Electrical Requirements

Table E2: WPVJ Electrical Performance (High Static Blower Option-continued)

Model No.	Volts/Hz/Ph	Total FLA	Comp. RLA (ea)	Comp. LRA (ea)	No. of Compres.	Cmp MCC	Blower Motor FLA	Blower Motor HP	Fan Motor Num	Minimum Circuit Ampacity	Overcurrent Protective Device	Desup	Desup RLA
WPVJ024	208/60/1	12.9	11.40	56.0	1	16.0	1.50	1/4	1	15.8	25	No	0
WPVJ024	208/60/1	13.11	11.40	56.0	1	16.0	1.50	1/4	1	16.0	25	Yes	0.21
WPVJ024	220-240/50/1	10.9	9.60	47.0	1	13.5	1.30	1/4	1	13.3	20	No	0
WPVJ024	230/60/1	12.9	11.40	56.0	1	16.0	1.50	1/4	1	15.8	25	No	0
WPVJ024	230/60/1	13.11	11.40	56.0	1	16.0	1.50	1/4	1	16.0	25	Yes	0.21
WPVJ024	265/60/1	10.9	9.60	47.0	1	13.5	1.30	1/4	1	13.3	20	No	0
WPVJ024	265/60/1	11.11	9.60	47.0	1	13.5	1.30	1/4	1	13.5	20	Yes	0.21
WPVJ030	208/60/1	15.1	13.60	67.0	1	19.0	1.50	1/4	1	18.5	30	No	0
WPVJ030	208/60/1	15.31	13.60	67.0	1	19.0	1.50	1/4	1	18.7	30	Yes	0.21
WPVJ030	220-240/50/1	14.4	12.10	58.0	1	17.0	2.30	1/3	1	17.4	25	No	0
WPVJ030	230/60/1	15.1	13.60	67.0	1	19.0	1.50	1/4	1	18.5	30	No	0
WPVJ030	230/60/1	15.31	13.60	67.0	1	19.0	1.50	1/4	1	18.7	30	Yes	0.21
WPVJ030	265/60/1	14.4	12.10	58.0	1	17.0	2.30	1/3	1	17.4	25	No	0
WPVJ030	265/60/1	14.61	12.10	58.0	1	17.0	2.30	1/3	1	17.6	25	Yes	0.21
WPVJ036	208/60/1	17.8	15.00	73.0	1	21.0	2.80	1/3	1	21.6	35	No	0
WPVJ036	208/60/1	18.01	15.00	73.0	1	21.0	2.80	1/3	1	21.8	35	Yes	0.21
WPVJ036	208/60/3	13.5	10.70	63.0	1	15.0	2.80	1/3	1	16.2	25	No	0
WPVJ036	208/60/3	13.71	10.70	63.0	1	15.0	2.80	1/3	1	16.4	25	Yes	0.21
WPVJ036	220-240/50/1	16.6	14.30	71.0	1	20.0	2.30	1/3	1	20.2	30	No	0
WPVJ036	230/60/1	17.8	15.00	73.0	1	21.0	2.80	1/3	1	21.6	35	No	0
WPVJ036	230/60/1	18.01	15.00	73.0	1	21.0	2.80	1/3	1	21.8	35	Yes	0.21
WPVJ036	230/60/3	13.5	10.70	63.0	1	15.0	2.80	1/3	1	16.2	25	No	0
WPVJ036	230/60/3	13.71	10.70	63.0	1	15.0	2.80	1/3	1	16.4	25	Yes	0.21
WPVJ036	265/60/1	16.6	14.30	71.0	1	20.0	2.30	1/3	1	20.2	30	No	0
WPVJ036	265/60/1	16.81	14.30	71.0	1	20.0	2.30	1/3	1	20.4	30	Yes	0.21
WPVJ036	380-415/50/3	6.4	5.00	31.0	1	7.0	1.40	1/2	1	7.7	15	No	0
WPVJ036	460/60/3	6.4	5.00	31.0	1	7.0	1.40	1/2	1	7.7	15	No	0
WPVJ036	460/60/3	6.61	5.00	31.0	1	7.0	1.40	1/2	1	7.9	15	Yes	0.21
WPVJ042	208/60/1	21.3	18.40	95.0	1	25.8	2.90	1/2	1	25.9	40	No	0
WPVJ042	208/60/1	21.51	18.40	95.0	1	25.8	2.90	1/2	1	26.1	40	Yes	0.21
WPVJ042	208/60/3	14.3	11.40	77.0	1	16.0	2.90	1/2	1	17.2	25	No	0
WPVJ042	208/60/3	14.51	11.40	77.0	1	16.0	2.90	1/2	1	17.4	25	Yes	0.21
WPVJ042	230/60/1	21.3	18.40	95.0	1	25.8	2.90	1/2	1	25.9	40	No	0
WPVJ042	230/60/1	21.51	18.40	95.0	1	25.8	2.90	1/2	1	26.1	40	Yes	0.21
WPVJ042	230/60/3	14.3	11.40	77.0	1	16.0	2.90	1/2	1	17.2	25	No	0
WPVJ042	230/60/3	14.51	11.40	77.0	1	16.0	2.90	1/2	1	17.4	25	Yes	0.21
WPVJ042	380-415/50/3	7.1	5.70	39.0	1	8.0	1.40	1/2	1	8.5	15	No	0
WPVJ042	460/60/3	7.1	5.70	39.0	1	8.0	1.40	1/2	1	8.5	15	No	0
WPVJ042	460/60/3	7.31	5.70	39.0	1	8.0	1.40	1/2	1	8.7	15	Yes	0.21
WPVJ048	208/60/1	23.3	20.40	109.0	1	28.6	2.90	1/2	1	28.4	45	No	0
WPVJ048	208/60/1	23.51	20.40	109.0	1	28.6	2.90	1/2	1	28.6	45	Yes	0.21
WPVJ048	208/60/3	16.8	13.90	88.0	1	19.4	2.90	1/2	1	20.3	30	No	0
WPVJ048	208/60/3	17.01	13.90	88.0	1	19.4	2.90	1/2	1	20.5	30	Yes	0.21
WPVJ048	230/60/1	23.3	20.40	109.0	1	28.6	2.90	1/2	1	28.4	45	No	0
WPVJ048	230/60/1	23.51	20.40	109.0	1	28.6	2.90	1/2	1	28.6	45	Yes	0.21
WPVJ048	230/60/3	16.8	13.90	88.0	1	19.4	2.90	1/2	1	20.3	30	No	0
WPVJ048	230/60/3	17.01	13.90	88.0	1	19.4	2.90	1/2	1	20.5	30	Yes	0.21
WPVJ048	380-415/50/3	8.5	7.10	44.0	1	10.0	1.40	1/2	1	10.3	15	No	0
WPVJ048	460/60/3	8.5	7.10	44.0	1	10.0	1.40	1/2	1	10.3	15	No	0
WPVJ048	460/60/3	8.71	7.10	44.0	1	10.0	1.40	1/2	1	10.5	15	Yes	0.21



Electrical Requirements

Table E2: WPVJ Electrical Performance (High Static Blower Option-continued)

Model No.	Volts/Hz/Ph	Total FLA	Comp. RLA (ea)	Comp. LRA (ea)	No. of Compres.	Comp MCC	Blower Motor FLA	Blower Motor HP	Fan Motor Num	Minimum Circuit Ampacity	Overcurrent Protective Device	Desup	Desup RLA
WPVJ060	208/60/1	33.5	28.00	169.0	1	39.0	5.50	3/4	1	40.5	60	No	0
WPVJ060	208/60/1	33.71	28.00	169.0	1	39.0	5.50	3/4	1	40.7	60	Yes	0.21
WPVJ060	208/60/3	24.8	19.30	123.0	1	27.0	5.50	3/4	1	29.6	45	No	0
WPVJ060	208/60/3	25.01	19.30	123.0	1	27.0	5.50	3/4	1	29.8	45	Yes	0.21
WPVJ060	230/60/1	33.5	28.00	169.0	1	39.0	5.50	3/4	1	40.5	60	No	0
WPVJ060	230/60/1	33.71	28.00	169.0	1	39.0	5.50	3/4	1	40.7	60	Yes	0.21
WPVJ060	230/60/3	24.8	19.30	123.0	1	27.0	5.50	3/4	1	29.6	45	No	0
WPVJ060	230/60/3	25.01	19.30	123.0	1	27.0	5.50	3/4	1	29.8	45	Yes	0.21
WPVJ060	380-415/50/3	10.8	7.50	49.5	1	10.5	3.30	3/4	1	12.7	20	No	0
WPVJ060	460/60/3	10.8	7.50	49.5	1	10.5	3.30	3/4	1	12.7	20	No	0
WPVJ060	460/60/3	11.01	7.50	49.5	1	10.5	3.30	3/4	1	12.9	20	Yes	0.21
WPVJ060	575/60/3	8.9	6.40	40.0	1	9.0	2.50	3/4	1	10.5	15	No	0
WPVJ060	575/60/3	9.11	6.40	40.0	1	9.0	2.50	3/4	1	10.7	15	Yes	0.21
WPVJ072	208/60/1	37.6	32.10	169.0	1	45.0	5.50	3/4	1	45.6	70	No	0
WPVJ072	208/60/1	37.81	32.10	169.0	1	45.0	5.50	3/4	1	45.8	70	Yes	0.21
WPVJ072	208/60/3	24.8	19.30	137.0	1	27.0	5.50	3/4	1	29.6	45	No	0
WPVJ072	208/60/3	25.01	19.30	137.0	1	27.0	5.50	3/4	1	29.8	45	Yes	0.21
WPVJ072	230/60/1	37.6	32.10	169.0	1	45.0	5.50	3/4	1	45.6	70	No	0
WPVJ072	230/60/1	37.81	32.10	169.0	1	45.0	5.50	3/4	1	45.8	70	Yes	0.21
WPVJ072	230/60/3	24.8	19.30	137.0	1	27.0	5.50	3/4	1	29.6	45	No	0
WPVJ072	230/60/3	25.01	19.30	137.0	1	27.0	5.50	3/4	1	29.8	45	Yes	0.21
WPVJ072	380-415/50/3	13.3	10.00	62.0	1	14.0	3.30	3/4	1	15.8	25	No	0
WPVJ072	460/60/3	13.3	10.00	62.0	1	14.0	3.30	3/4	1	15.8	25	No	0
WPVJ072	460/60/3	13.51	10.00	62.0	1	14.0	3.30	3/4	1	16.0	25	Yes	0.21
WPVJ072	575/60/3	10.4	7.90	50.0	1	11.0	2.50	3/4	1	12.4	20	No	0
WPVJ072	575/60/3	10.61	7.90	50.0	1	11.0	2.50	3/4	1	12.6	20	Yes	0.21

Table E3: WPHF Electrical Performance (Standard Static Blower Option)

Model No.	Volts/Hz/Ph	Blower Motor HP	Blower Motor FLA	Compr. RLA	Compr. MCC	Compr. LRA	Minimum Circuit Amps	UL Max Fuse or HACR	CSA Max. Fuse Size	CASE Max. Circuit Brkr
WPHF021	208/60/1	1/8	1.3	8.0	12.5	45	11.3	15	20	15
WPHF021	230/60/1	1/8	1.3	8.0	12.5	45	11.3	15	20	15
WPHF021	265/60/1	1/8	1.1	7.0	10.9	39	9.9	15	20	15
WPHF027	208/60/1	1/5	1.2	11.0	17.2	60	15.0	25	30	25
WPHF027	230/60/1	1/5	1.2	11.0	17.2	60	15.0	25	30	25
WPHF027	265/60/1	1/5	2.4	9.6	15.0	52	14.4	20	25	20
WPHF035	208/60/1	1/5	2.0	12.4	19.4	65	17.5	30	35	25
WPHF035	230/60/1	1/5	2.0	12.4	19.4	65	17.5	30	35	25
WPHF035	265/60/1	1/5	2.4	10.8	16.9	57	15.9	25	30	25
WPHF040	208/60/1	1/3	2.8	15.1	23.5	85	21.7	35	45	35
WPHF040	230/60/1	1/3	2.8	15.1	23.5	85	21.7	35	45	35
WPHF040	265/60/1	1/3	2.0	13.2	20.5	74	18.5	30	40	30
WPHF040	208/60/3	1/3	2.8	10.6	16.5	101	16.1	25	50	40
WPHF040	230/60/3	1/3	2.8	10.6	16.5	101	13.1	25	50	40
WPHF040	265/60/3	1/3	2.0	4.2	6.6	51	7.3	15	25	20
WPHF047	208/60/1	1/3	2.8	14.6	22.8	92	21.1	35	50	40
WPHF047	230/60/1	1/3	2.8	14.6	22.8	92	21.1	35	50	40
WPHF047	208/60/3	1/3	2.8	10.6	16.5	101	16.1	25	50	40
WPHF047	230/60/3	1/3	2.8	10.6	16.5	101	16.1	25	50	40
WPHF047	460/60/3	1/3	1.1	4.2	6.6	51	6.4	15	25	20



Electrical Requirements

Table E3: WPHF Electrical Performance (Standard Static Blower Option-continued)

Model No.	Volts/Hz/Ph	Blower Motor HP	Blower Motor FLA	Compr. RLA	Compr. MCC	Compr. LRA	Minimum Circuit Amps	UL Max Fuse or HACR	CSA Max. Fuse Size	CASE Max. Circuit Brkr
WPHF057	208/60/1	1/2	4.1	22.3	34.8	122	32.0	50	60	50
WPHF057	230/60/1	1/2	4.1	22.3	34.8	122	32.0	50	60	50
WPHF057	208/60/3	1/2	4.1	14.4	25.5	101	22.1	35	50	45
WPHF057	230/60/3	1/2	4.1	14.4	25.5	101	22.1	35	50	45
WPHF057	460/60/3	1/2	1.8	7.1	11.1	51	10.7	15	20	20

Table E4: WPHF Electrical Performance (High Static Blower Option)

Model No.	Volts/Hz/Ph	Blower Motor HP	Blower Motor FLA	Compr. RLA	Compr. MCC	Compr. LRA	Minimum Circuit Amps	UL Max Fuse or HACR	CSA Max. Fuse Size	CASE Max. Circuit Brkr
WPHF047	208/60/1	1/2	4.6	14.6	22.8	92	22.9	35	50	40
WPHF047	230/60/1	1/2	4.6	14.6	22.8	92	22.9	35	50	40
WPHF047	208/60/3	1/2	4.6	10.6	16.5	101	17.9	25	50	45
WPHF047	230/60/3	1/2	4.6	10.6	16.5	101	17.9	25	50	45
WPHF047	460/60/3	1/2	2.2	4.2	6.6	51	7.5	15	25	20
WPHF057	208/60/1	1/2	4.6	22.3	34.8	122	32.5	50	60	50
WPHF057	230/60/1	1/2	4.6	22.3	34.8	122	32.5	50	60	50
WPHF057	208/60/3	1/2	4.6	14.4	22.5	101	22.6	35	50	45
WPHF057	230/60/3	1/2	4.6	14.4	22.5	101	22.6	35	50	45
WPHF057	460/60/3	1/2	2.2	7.1	11.1	51	11.1	15	25	20



Pre-Start Checklist

Pre-Start-up Checklist

Before energizing the unit, the following system devices must be checked:

- Is the high voltage power supply correct and in accordance with the nameplate ratings?
- Is the field wiring and circuit protection the correct size?
- Is the low voltage control circuit wiring correct per the unit wiring diagram?
- Is the piping system clean/complete and correct? *(A recommendation of all system flushing of debris from the water-to-refrigerant heat exchanger, along with air purging from the water-to-refrigerant heat exchanger be done in accordance with the Closed-Loop/Ground Source Heat Pump Systems Installation Guide).*
- Is vibration isolation provided? (i.e. unit isolation pad, hosekits)
- Is unit serviceable? *(See clearance specifications on page 6).*
- Are the low/high-side pressure temperature caps secure and in place?
- Are all the unit access panels secure and in place?
- Is the thermostat in the OFF position?
- Is the water flow established and circulating through all the units?
- Is the duct work (if required) correctly sized, run, taped, insulated and weather proofed with proper unit arrangement?
- Is the condensate line properly sized, run, trapped and pitched?
- Does the indoor blower turn freely without rubbing?
- Has all work been done in accordance with applicable local and national codes?
- Has heat transfer fluid been added in the proper mix to prevent freezing in closed system application?



Sequence of Operation

Initial Unit Start-up

Start-up for 24V (basic) controls is included below:

Note: Start-up for the Tracer™ ZN510 controller may be found in WSHP-IOP-2.

1. Set the thermostat to the highest position.
2. Set the thermostat system switch to COOL with the fan control to AUTO. *The compressor should NOT run.*
3. Reduce the temperature control setting until the compressor, reversing valve, solenoid valve, and loop pump are energized. *Adjust water flow utilizing pressure/temperature plugs and comparing to tables contained in specification sheet data. Water leaving the heat exchanger should be warmer than the entering water temperature (approximately 9°F-12°F); blower operation should be smooth; compressor and blower amps should be within data plate ratings; the suction line should be cool with no frost observed in the refrigerant circuit.*
4. Check the cooling refrigerant pressures against values in Table OP1. (Page 27).
5. Turn the thermostat switch to the OFF position. *Unit should stop running and the reversing valve should de-energize.*
6. Leave unit off for approximately FIVE minutes to allow for pressure equalization.
7. Turn the thermostat to the lowest setting.
8. Set the thermostat system switch to the HEAT position.
9. Adjust the temperature setting upward until the unit is energized. *Warm air should blow from the register. A water temperature decrease of approximately 5°F-9°F leaving the heat exchanger should be noted. The blower and compressor operation should be smooth with no frost observed in the refrigeration circuit.*
10. Check the heating refrigerant pressures against values in Table OP1. (Page 27)
11. Set the thermostat to maintain the desired space temperature.
12. Instruct the owner on system operation.

Operating Pressures WPVJ

Operating Pressures

GENERAL: There are many variables (airflow, air temperatures) in an air conditioning system that will affect operating refrigerant pressures and temperatures. The charts below show approximate conditions and is based on air flow at the rated SCFM, entering air at 80.6 °F(DB), 66.2 °F(WB) in cooling, 68 °F(DB) in heating. (+)Heating data with 35 °F EWT is based on the use of an anti-freeze solution having a freezing point 20 °F lower than the minimum expected entering temperature.

Table OP-1: Operating pressures and temperature for PSC motor

Units with PSC motors			Operating Data							
Model	Entering Water Temp, °F	Water Flow GPM	Cooling				Heating			
			Suction Pressure, PSIG	Discharge Pressure, PSIG	Water Temp Rise, °F	Air Temp Drop, °FDB	Suction Pressure, PSIG	Discharge Pressure, PSIG	Water Temp Drop, °F	Air Temp Rise, °FDB
WPVJ 018	35	4					42 - 49	176 - 224	2 - 2	21 - 27
WPVJ 018	35	5					43 - 50	177 - 226	2 - 2	22 - 28
WPVJ 018	45	4	66 - 76	101 - 129	11 - 14	20 - 25	51 - 58	188 - 239	3 - 3	25 - 31
WPVJ 018	45	5	66 - 76	98 - 125	9 - 11	20 - 26	52 - 60	189 - 241	2 - 3	25 - 32
WPVJ 018	55	4	69 - 79	119 - 152	11 - 14	20 - 25	59 - 68	199 - 253	3 - 4	28 - 35
WPVJ 018	55	5	68 - 78	116 - 147	9 - 11	20 - 25	60 - 70	200 - 255	3 - 3	29 - 36
WPVJ 018	68	4	71 - 82	146 - 186	11 - 13	19 - 24	70 - 81	212 - 270	4 - 5	32 - 40
WPVJ 018	68	5	71 - 81	142 - 181	8 - 11	19 - 24	72 - 82	214 - 273	3 - 4	33 - 42
WPVJ 018	75	4	72 - 83	162 - 207	10 - 13	18 - 24	76 - 88	220 - 280	4 - 5	34 - 43
WPVJ 018	75	5	72 - 82	158 - 201	8 - 11	19 - 24	78 - 90	222 - 282	4 - 5	35 - 44
WPVJ 018	86	4	73 - 84	191 - 243	10 - 13	18 - 23	86 - 99	232 - 295	5 - 6	37 - 47
WPVJ 018	86	5	73 - 84	186 - 237	8 - 11	18 - 23	88 - 101	234 - 298	4 - 5	38 - 49
WPVJ 018	95	4	74 - 85	217 - 277	10 - 13	17 - 22				
WPVJ 018	95	5	74 - 85	212 - 270	8 - 10	17 - 22				
WPVJ 024	35	4.88					42 - 49	177 - 225	3 - 4	21 - 27
WPVJ 024	35	6.1					43 - 49	178 - 227	3 - 3	22 - 27
WPVJ 024	45	4.88	64 - 74	103 - 132	11 - 13	19 - 24	51 - 58	187 - 238	4 - 5	24 - 30
WPVJ 024	45	6.1	64 - 73	100 - 128	9 - 11	19 - 25	51 - 59	189 - 240	3 - 4	25 - 31
WPVJ 024	55	4.88	68 - 78	120 - 153	11 - 13	19 - 24	60 - 68	197 - 251	4 - 6	27 - 34
WPVJ 024	55	6.1	67 - 77	117 - 149	8 - 11	19 - 24	60 - 69	199 - 253	4 - 5	27 - 35
WPVJ 024	68	4.88	71 - 82	147 - 187	10 - 13	18 - 23	71 - 82	210 - 268	5 - 7	30 - 39
WPVJ 024	68	6.1	71 - 81	143 - 182	8 - 11	18 - 23	72 - 83	212 - 270	4 - 5	31 - 40
WPVJ 024	75	4.88	72 - 83	164 - 208	10 - 13	18 - 22	77 - 89	218 - 277	6 - 7	32 - 41
WPVJ 024	75	6.1	72 - 83	159 - 202	8 - 11	18 - 23	78 - 90	220 - 280	5 - 6	33 - 42
WPVJ 024	86	4.88	74 - 85	193 - 245	10 - 13	17 - 22	86 - 99	229 - 292	6 - 8	35 - 45
WPVJ 024	86	6.1	74 - 85	187 - 238	8 - 11	17 - 22	87 - 100	232 - 295	5 - 7	36 - 46
WPVJ 024	95	4.88	75 - 87	219 - 279	10 - 13	17 - 21				
WPVJ 024	95	6.1	75 - 87	213 - 271	8 - 11	17 - 22				
WPVJ 030	35	5.76					43 - 50	163 - 207	4 - 5	21 - 26
WPVJ 030	35	7.2					43 - 50	164 - 209	3 - 4	21 - 27
WPVJ 030	45	5.76	63 - 72	103 - 131	11 - 14	19 - 24	51 - 59	172 - 219	4 - 5	23 - 29
WPVJ 030	45	7.2	61 - 71	98 - 125	9 - 11	19 - 24	52 - 59	173 - 221	4 - 5	24 - 30
WPVJ 030	55	5.76	68 - 79	121 - 154	11 - 14	18 - 23	59 - 68	179 - 228	5 - 6	26 - 32
WPVJ 030	55	7.2	67 - 77	116 - 148	9 - 11	18 - 24	60 - 68	181 - 230	4 - 5	26 - 33
WPVJ 030	68	5.76	72 - 83	148 - 188	11 - 14	18 - 23	68 - 78	188 - 239	6 - 7	28 - 36
WPVJ 030	68	7.2	72 - 83	142 - 181	9 - 11	18 - 23	69 - 79	189 - 241	5 - 6	29 - 37
WPVJ 030	75	5.76	74 - 85	164 - 209	11 - 14	17 - 22	73 - 83	193 - 246	6 - 8	30 - 38
WPVJ 030	75	7.2	73 - 85	158 - 201	9 - 11	18 - 22	73 - 84	195 - 248	5 - 6	30 - 39
WPVJ 030	86	5.76	76 - 87	192 - 244	11 - 14	17 - 22	78 - 90	199 - 253	7 - 8	32 - 40
WPVJ 030	86	7.2	76 - 87	185 - 235	9 - 11	17 - 22	78 - 90	200 - 254	5 - 7	32 - 41
WPVJ 030	95	5.76	77 - 89	217 - 276	11 - 14	17 - 21				
WPVJ 030	95	7.2	77 - 89	209 - 266	9 - 11	17 - 21				
WPVJ 036	35	6.88					41 - 47	162 - 206	4 - 5	20 - 25
WPVJ 036	35	8.6					42 - 48	162 - 206	3 - 4	21 - 26
WPVJ 036	45	6.88	66 - 76	109 - 138	11 - 14	19 - 25	50 - 57	170 - 217	5 - 6	22 - 29
WPVJ 036	45	8.6	66 - 75	105 - 134	9 - 12	19 - 25	51 - 58	170 - 217	4 - 5	23 - 29
WPVJ 036	55	6.88	71 - 81	126 - 161	11 - 14	19 - 24	59 - 68	180 - 229	6 - 7	25 - 32
WPVJ 036	55	8.6	70 - 81	122 - 155	9 - 12	19 - 24	60 - 69	180 - 229	5 - 6	26 - 33
WPVJ 036	68	6.88	74 - 85	154 - 195	11 - 14	18 - 24	71 - 82	192 - 244	7 - 8	29 - 37
WPVJ 036	68	8.6	73 - 84	148 - 188	9 - 11	19 - 24	72 - 83	192 - 244	5 - 7	30 - 38
WPVJ 036	75	6.88	75 - 86	170 - 217	11 - 14	18 - 23	77 - 89	198 - 251	7 - 9	31 - 39
WPVJ 036	75	8.6	74 - 86	164 - 209	9 - 11	18 - 23	78 - 90	198 - 252	6 - 7	31 - 40
WPVJ 036	86	6.88	77 - 88	200 - 255	11 - 14	18 - 22	85 - 97	206 - 262	8 - 10	33 - 42
WPVJ 036	86	8.6	76 - 88	193 - 246	9 - 11	18 - 23	86 - 99	206 - 263	6 - 8	33 - 43
WPVJ 036	95	6.88	78 - 90	228 - 290	11 - 14	17 - 22				
WPVJ 036	95	8.6	78 - 89	220 - 280	9 - 11	17 - 22				



Operating Pressure

Table OP-1: Operating pressures and temperature for PSC motor

Units with PSC motors			Operating Data							
Model	Entering Water Temp, °F	Water Flow GPM	Cooling				Heating			
			Suction Pressure, PSIG	Discharge Pressure, PSIG	Water Temp Rise, °F	Air Temp Drop, °FDB	Suction Pressure, PSIG	Discharge Pressure, PSIG	Water Temp Drop, °F	Air Temp Rise, °FDB
WPVJ 042	35	8.08					42 - 48	164 - 209	5 - 6	19 - 25
WPVJ 042	35	10.1					43 - 49	165 - 210	4 - 5	20 - 25
WPVJ 042	45	8.08	63 - 72	108 - 137	12 - 16	24 - 30	50 - 57	171 - 218	5 - 7	22 - 28
WPVJ 042	45	10.1	60 - 69	105 - 134	10 - 12	24 - 30	51 - 58	172 - 219	4 - 6	22 - 28
WPVJ 042	55	8.08	69 - 79	124 - 158	12 - 15	22 - 28	58 - 67	181 - 230	6 - 8	25 - 32
WPVJ 042	55	10.1	67 - 77	121 - 154	10 - 12	22 - 28	60 - 69	182 - 231	5 - 6	25 - 32
WPVJ 042	68	8.08	75 - 86	150 - 191	12 - 15	21 - 26	69 - 80	192 - 245	7 - 9	28 - 36
WPVJ 042	68	10.1	73 - 84	145 - 185	9 - 12	21 - 26	70 - 81	193 - 246	6 - 7	28 - 36
WPVJ 042	75	8.08	77 - 88	165 - 211	11 - 15	20 - 26	73 - 84	196 - 249	7 - 10	29 - 37
WPVJ 042	75	10.1	75 - 86	160 - 204	9 - 12	20 - 26	74 - 85	197 - 250	6 - 8	29 - 38
WPVJ 042	86	8.08	79 - 91	193 - 246	11 - 14	19 - 25	76 - 87	199 - 253	8 - 10	30 - 38
WPVJ 042	86	10.1	77 - 89	187 - 238	9 - 12	20 - 25	77 - 88	200 - 254	6 - 8	30 - 39
WPVJ 042	95	8.08	80 - 92	218 - 278	11 - 14	19 - 24				
WPVJ 042	95	10.1	79 - 91	212 - 270	9 - 11	19 - 24				
WPVJ 048	35	9.2					44 - 51	170 - 216	5 - 7	23 - 29
WPVJ 048	35	11.5					44 - 50	171 - 218	4 - 6	23 - 29
WPVJ 048	45	9.2	58 - 67	109 - 139	11 - 14	20 - 26	53 - 62	180 - 230	6 - 8	26 - 33
WPVJ 048	45	11.5	56 - 64	103 - 131	9 - 12	20 - 26	53 - 61	182 - 231	5 - 7	26 - 34
WPVJ 048	55	9.2	65 - 75	129 - 164	11 - 14	19 - 25	63 - 72	192 - 244	7 - 9	29 - 37
WPVJ 048	55	11.5	64 - 73	123 - 156	9 - 11	19 - 25	62 - 71	193 - 246	6 - 8	29 - 38
WPVJ 048	68	9.2	71 - 81	156 - 199	11 - 14	19 - 24	72 - 82	204 - 260	8 - 10	32 - 41
WPVJ 048	68	11.5	70 - 80	149 - 190	9 - 11	19 - 24	71 - 82	205 - 261	7 - 9	33 - 41
WPVJ 048	75	9.2	73 - 83	172 - 219	11 - 14	18 - 23	75 - 86	208 - 265	9 - 11	33 - 42
WPVJ 048	75	11.5	72 - 83	165 - 210	9 - 11	18 - 23	74 - 85	210 - 267	7 - 9	34 - 43
WPVJ 048	86	9.2	75 - 86	200 - 255	11 - 14	18 - 22	78 - 90	214 - 272	9 - 11	34 - 44
WPVJ 048	86	11.5	74 - 85	192 - 245	9 - 11	18 - 23	77 - 89	215 - 274	7 - 9	35 - 44
WPVJ 048	95	9.2	76 - 87	226 - 288	11 - 14	17 - 22				
WPVJ 048	95	11.5	76 - 87	218 - 277	9 - 11	17 - 22				
WPVJ 060	35	11.92					41 - 47	160 - 204	6 - 7	20 - 26
WPVJ 060	35	14.9					41 - 47	162 - 206	4 - 6	21 - 26
WPVJ 060	45	11.92	66 - 75	110 - 140	13 - 16	23 - 30	51 - 58	169 - 215	6 - 8	23 - 29
WPVJ 060	45	14.9	64 - 73	106 - 135	10 - 13	23 - 30	51 - 59	171 - 217	5 - 7	24 - 30
WPVJ 060	55	11.92	72 - 82	128 - 163	12 - 16	23 - 29	61 - 70	179 - 228	7 - 9	26 - 33
WPVJ 060	55	14.9	71 - 82	123 - 157	10 - 13	23 - 29	61 - 70	180 - 230	6 - 8	27 - 34
WPVJ 060	68	11.92	74 - 85	155 - 197	12 - 15	21 - 27	73 - 84	194 - 247	9 - 11	30 - 38
WPVJ 060	68	14.9	74 - 85	149 - 190	10 - 12	22 - 27	74 - 85	195 - 249	7 - 9	31 - 39
WPVJ 060	75	11.92	74 - 85	171 - 218	12 - 15	21 - 27	80 - 92	202 - 257	9 - 12	32 - 41
WPVJ 060	75	14.9	74 - 85	165 - 210	9 - 12	21 - 27	81 - 93	203 - 258	7 - 10	33 - 41
WPVJ 060	86	11.92	75 - 86	199 - 254	11 - 14	20 - 25	88 - 101	207 - 264	10 - 13	35 - 44
WPVJ 060	86	14.9	75 - 86	193 - 246	9 - 12	20 - 25	89 - 102	209 - 266	8 - 10	35 - 45
WPVJ 060	95	11.92	76 - 87	225 - 286	11 - 14	19 - 24				
WPVJ 060	95	14.9	76 - 87	218 - 278	9 - 11	19 - 24				
WPVJ 072	35	13.2					37 - 43	163 - 207	6 - 7	20 - 26
WPVJ 072	35	16.5					40 - 47	164 - 209	5 - 6	21 - 27
WPVJ 072	45	13.2	64 - 74	119 - 152	12 - 16	23 - 29	46 - 53	173 - 220	7 - 8	23 - 29
WPVJ 072	45	16.5	62 - 72	113 - 144	10 - 13	23 - 29	50 - 58	174 - 222	5 - 7	24 - 30
WPVJ 072	55	13.2	69 - 80	137 - 175	12 - 15	22 - 28	57 - 65	185 - 236	8 - 10	27 - 34
WPVJ 072	55	16.5	68 - 78	131 - 167	10 - 12	22 - 28	61 - 70	187 - 238	6 - 8	27 - 34
WPVJ 072	68	13.2	71 - 82	162 - 207	12 - 15	21 - 27	70 - 80	201 - 256	9 - 12	31 - 40
WPVJ 072	68	16.5	71 - 82	155 - 197	9 - 12	21 - 27	74 - 85	203 - 258	7 - 9	32 - 40
WPVJ 072	75	13.2	72 - 83	178 - 226	12 - 15	21 - 26	75 - 87	207 - 264	10 - 12	33 - 42
WPVJ 072	75	16.5	72 - 82	170 - 216	9 - 12	21 - 26	79 - 91	209 - 266	8 - 10	33 - 42
WPVJ 072	86	13.2	73 - 84	205 - 261	11 - 14	20 - 25	81 - 94	216 - 274	10 - 13	34 - 44
WPVJ 072	86	16.5	72 - 83	197 - 250	9 - 11	20 - 25	85 - 98	217 - 276	8 - 11	35 - 44
WPVJ 072	95	13.2	74 - 85	230 - 292	11 - 14	19 - 24				
WPVJ 072	95	16.5	73 - 84	221 - 281	9 - 11	19 - 24				

Operating Pressures

Water Pressure Drop

Table 4 should be used to define feet of head/pressure drop. *Note: To calculate feet of head, when using gauges that read in PSIG, multiply PSI by 2.31.*

Table 4: Water pressure drops (WPD) in feet of head

Unit Size	GPM	Cooling		Heating	
		EWT F	Ft. Head Pressure	EWT F	Ft. Head Pressure
WPVJ 018	5.0	77	7.5	55	9.0
WPVJ 024	6.1		10.2		12.1
WPVJ 030	7.2		4.9		6.0
WPVJ 036	8.6		6.7		7.9
WPVJ 042	10.1		8.8		10.0
WPVJ 048	11.5		7.8		9.0
WPVJ 060	14.9		12.4		14.1
WPVJ 072	16.5		14.8		14.1
WPHF 021	5.3	77	6.9	55	7.6
WPHF 027	6.8		11.1		12.3
WPHF 035	8.7		17.9		19.8
WPHF 040	9.9		23.1		25.6
WPHF 047	11.6		15.0		16.6
WPHF 057	14.1		22.0		24.4

Water Volume

Table 5 is provided for use in calculating glycol requirements for the WPVJ unit.

Unit Model	Unit Size	Water Side Volume Cubic In.	Water Side Volume Cubic In.	Water Side Volume Gallons.
WPVJ	018-024	55	0.032	0.238
WPVJ	030-042	105	0.061	0.455
WPVJ	048-072	259	0.150	1.121

Flow Checks

For the operating temperature drop (heating) and rise (cooling), refer to Table OP1 and OP2 for the proper water temperature change. Depending on the unit size, entering water temperature and water flow rate, the cooling temperature rise is from 8°F-16°F. Based on the same criteria for heating, the temperature drop is from 2°F-13°F.

Pressure

Using the P/T ports and one 0-60 psi pressure gauge with the P/T port adapter, measure the pressure difference between the water-in and water-out connections.

Start-up Checklist and Log

Use the form on page 30 to log system and unit temperatures during start-up.

WARNING

Live Electrical Components!

During installation, testing, servicing and troubleshooting of this product, it may be necessary to work with live electrical components. Have a qualified licensed electrician or other individual who has been properly trained in handling live electrical components perform these tasks. Failure to follow all electrical safety precautions when exposed to live electrical components could result in death or serious injury.



Start-up Checklist and Log

Installing Contractor: Use this form to thoroughly check-out the system and units before and during start-up. (This form need not be returned to the factory unless requested during technical service support).

Job Name: _____

Model Number: _____

Date: _____

Serial Number: _____

In order to minimize troubleshooting and costly system failures, complete the following checks and data entries before the system is put into full operation.

MODE	HEAT	COOL
-------------	-------------	-------------

Entering fluid temperature	<input type="text" value="F"/>	<input type="text" value="F"/>
----------------------------	--------------------------------	--------------------------------

Leaving fluid temperature	<input type="text" value="F"/>	<input type="text" value="F"/>
---------------------------	--------------------------------	--------------------------------

Temperature differential	<input type="text" value="F"/>	<input type="text" value="F"/>
--------------------------	--------------------------------	--------------------------------

Return-air temperature DB/WB	<input type="text" value="F"/>	<input type="text" value="F"/>
------------------------------	--------------------------------	--------------------------------

Supply-air temperature DB/WB	<input type="text" value="F"/>	<input type="text" value="F"/>
------------------------------	--------------------------------	--------------------------------

Temperature differential	<input type="text" value="F"/>	<input type="text" value="F"/>
--------------------------	--------------------------------	--------------------------------

Water coil heat exchanger (Water Pressure IN)	<input type="text" value="PSIG"/>	<input type="text" value="PSIG"/>
--	-----------------------------------	-----------------------------------

Water coil heat exchanger (Water Pressure OUT)	<input type="text" value="PSIG"/>	<input type="text" value="PSIG"/>
---	-----------------------------------	-----------------------------------

Pressure Differential	<input type="text" value="PSIG"/>	<input type="text" value="PSIG"/>
-----------------------	-----------------------------------	-----------------------------------

COMPRESSOR

Amps	<input type="text"/>	<input type="text"/>
------	----------------------	----------------------

Volts	<input type="text"/>	<input type="text"/>
-------	----------------------	----------------------

Discharge line temperature (after 10 minutes)	<input type="text" value="F"/>	<input type="text" value="F"/>
--	--------------------------------	--------------------------------

Maintenance

Preventive Maintenance

Maintenance on the unit is simplified with the following preventive suggestions:

Filter maintenance must be performed to assure proper operation of the equipment. Filters should be inspected at least every three months, and replaced when it is evident they are dirty. Filter sizing includes:

Model WPVJ	Filter Size (nominal)
018, 024	16 x 20
030-042	20 x 25
048-072	20 x 30
Model WPHF	Filter Size (nominal)
021-027	16 x 24
035-040	(1) 16 x 16 (1) 16 x 20
047-057	18 x 20

WARNING Hazardous Voltage!

Disconnect all electric power, including remote disconnects before servicing. Follow proper lockout/tagout procedures to ensure the power can not be inadvertently energized. Failure to disconnect power before servicing could result in death or serious injury.

Check the contactors and relays within the control panel at least once a year. It is good practice to check the tightness of the various wiring connections within the control panel.

A strainer (60 mesh or greater) must be used on an open loop system to keep debris from entering the unit heat exchanger and to ensure a clean system.

For units on well water, it is important to check the cleanliness of the water-to-refrigerant heat exchanger. Should it become contaminated with dirt and scaling as a result of bad water, the

heat exchanger will have to be back flushed and cleaned with a chemical that will remove the scale. This service should be performed by an experienced service person.

WARNING Hazardous Chemicals!

Coil cleaning agents can be either acidic or highly alkaline. Handle chemical carefully. Proper handling should include goggles or face shield, chemical resistant gloves, boots, apron or suit as required. For personal safety, refer to the cleaning agent manufacturers Materials Safety Data Sheet and follow all recommended safe handling practices. Failure to follow all safety instructions could result in death or serious injury.

It should be noted that the water quality should be checked periodically. See Table 6.

Table 6: Water Quality Table

Scaling	
Calcium and magnesium (total hardness)	Less than 350 ppm
Corrosion	
pH	7-9.5
Hydrogen Sulfide	Less than 1 ppm
Sulfates	Less than 25 ppm
Chlorides	Less than 125 ppm
Carbon Dioxide	Less than 75 ppm
Total dissolved solids (TDS)	Less than 1000 ppm
Biological Growth	
Iron Bacteria	Low
Erosion	
Suspended Solids	Low



Warranty Information

Warranty Information

Standard Warranty

The standard water-source heat pump warranty is Trane's parts-only warranty, running 12-months from start-up, not to exceed 18-months from shipment.

Extended Warranty

The *optional* extended warranty is a second through fifth year warranty. The time starts at the end of standard 1-year coverage through the fifth year.

These extended warranties apply only to new equipment installed in domestic Trane Commercial Systems Group sales territories and must be ordered prior to start-up.

Troubleshooting

WARNING **Hazardous Service Procedures!**

The maintenance and troubleshooting procedures recommended in this section of the manual could result in exposure to electrical, mechanical or other potential safety hazards. Always refer to the safety warnings provided throughout this manual concerning these procedures. When possible, disconnect all electrical power including remote disconnects before servicing. Follow proper lockout/tagout procedures to ensure the power can not be inadvertently energized. When necessary to work with live electrical components, have a qualified licensed electrician or other individual who has been trained in handling live electrical components per these tasks. Failure to follow all of the recommended safety warnings provided, could result in death or serious injury.

Preliminary Trouble Inspection

If operational difficulties are encountered, be sure to perform the preliminary checks before referring to the troubleshooting chart on page 34.

- Verify that the unit is receiving electric supply power.
- Ensure that the fuses in the fused disconnect are intact.

After completing the preliminary checks, inspect the unit for other obvious problems such as leaking connection, broken or disconnected wires, etc. If everything appears to be in order, but the unit still fails to operate properly, refer to the troubleshooting chart on page 34.

General Operation

The standard model is designed for indoor installation. When the unit is installed in an unconditioned space, the unit may not start in cool weather (approximately 45°F). It may then be necessary to start the unit in the cooling mode for three to five minutes. The unit may then be shut-off (there will be a two minute time-out of the unit), and restarted in the heating mode.

Like any other type of mechanical equipment, the unit performs best when it is well maintained.

Operation with a Conventional Thermostat

The unit is equipped with safety controls, including high pressure control and low pressure control to shut off the compressor under abnormal pressure conditions. If the safeties shut off the compressor, a lockout relay prevents short cycling from the abnormal condition. When conditions are corrected, the lockout control can be reset by setting the thermostat system switch to OFF wait a few minutes for the system pressure to equalize, and then return to HEAT or COOL. If the condition continues, an authorized service person should check out the unit.

Troubleshooting Checklist

Problem	Heating	Cooling	Cause	Correction
No response to any thermostat setting	X	X	Main power off	Check fuses
	X	X	Defective control transformer	Replace
	X	X	Broken or loose connection	Repair
	X	X	Defective thermostat	Replace
	X	X	Transformer	Reset Transformer
Unit short cycles	X	X	Thermostat or sensor improperly located	Relocate
	X	X	Defective compressor overload	Replace (if external)
Blower runs, but compressor does not	X	X	Defective compressor contactor	Replace
	X	X	Supply Voltage too low	Correct
	X	X	Defective compressor capacitor	Replace
	X	X	Defective windings	Replace
	X	X	Limit switches open	Check cause/Replace or repair
Insufficient capacity	X	X	Dirty filter	Replace/clean
	X	X	Blower RPM too low	Correct
	X	X	Loss of conditioned air due to leaks in ductwork	Repair leaks
		X	Introduction of excessively hot return-air	Correct
	X		Introduction of excessively cold return-air	Correct
	X	X	Low on refrigerant charge	Locate leak, repair and recharge by weight (not by superheat)
	X	X	Restricted thermal expansion valve	Replace
	X	X	Defective reversing valve	Replace
	X	X	Thermostat improperly located	Relocate
	X	X	Unit undersized	Recalculate heat gains/losses
	X	X	Inadequate water flow	Increase GPM
	X	X	Scaling in heat exchanger	Clean or replace
High pressure switch open		X	Water too hot	Decrease temperature
	X		Water too cold	Increase temperature
		X	Inadequate GPM	Increase water flow to unit
		X	Water too hot	Decrease temperature
	X		Inadequate air flow	Check, clean blower and coil
	X		Dirty filter	Clean/replace
	X	X	Overcharged with refrigerant	Decrease charge
High head pressure	X	X	Defective pressure switch	Check or replace
		X	Trash in heat exchanger	Backflush
		X	Low water flow	Increase GPM
	X	X	Overcharge of refrigerant	Decrease charge
	X	X	Non-condensable in system	Evacuate and recharge by weight
	X	X	Water too hot	Decrease temperature
Low suction pressure	X		Dirty filter	Clean / replace
	X		Inadequate air flow	Check, clean blower and coil
	X	X	Undercharged	Locate leak, repair and recharge
	X	X	Restricted thermal expansion valve	Repair / replace
		X	Inadequate air flow	Check, clean blower and coil
Low Pressure switch open		X	Dirty filter	Clean/replace
	X		Inadequate GPM	Increase GPM
	X		Inadequate GPM	Increase GPM
	X		Water too cold	Increase temperature
		X	Inadequate air flow	Increase CFM
Low Pressure switch open		X	Dirty filter	Clean/replace
	X	X	Undercharged with refrigerant	Increase charge
	X	X	Defective pressure switch	Replace
	X	X	Heat transfer fluid too cold	Raise water temperature

Unit Wiring WPVJ Basic 24V Diagram

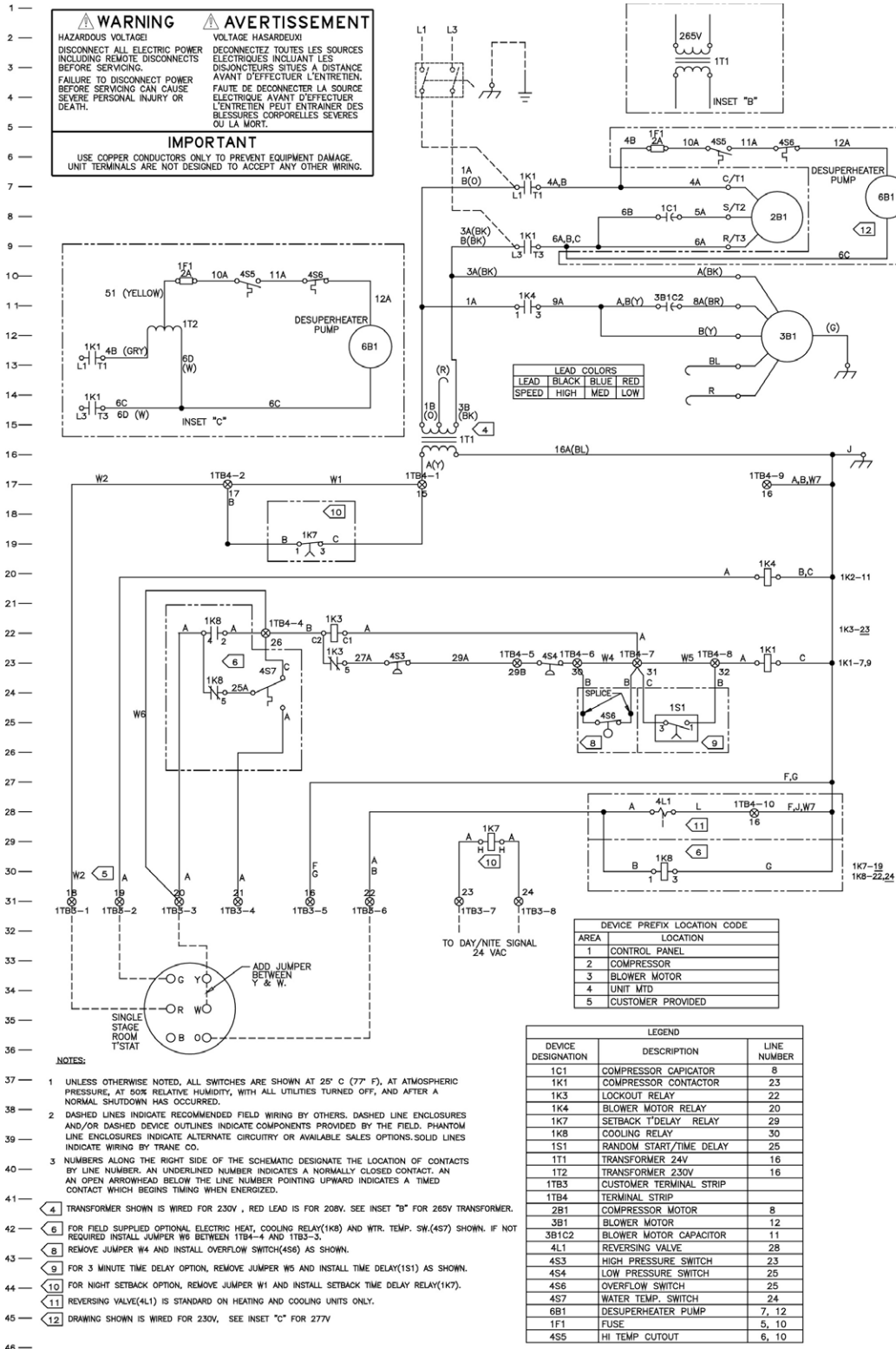

Unit Wiring WPVJ Tracer ZN510 Diagram

MOTOR SPEED TAP		
HIGH	MED	LOW
BLK	BLU	RED

FOR MED & LOW SPEED
TIE BLACK & PURPLE
ON 460V UNIT ONLY

⚠ WARNING
HAZARDOUS VOLTAGE!
DISCONNECT ALL ELECTRIC POWER INCLUDING REMOTE DISCONNECTS BEFORE SERVICING.
FAILURE TO DISCONNECT POWER BEFORE SERVICING CAN CAUSE SEVERE PERSONAL INJURY OR DEATH.

⚠ AVERTISSEMENT
VOLTAGE HASARDEUX!
DECONNECTEZ TOUTES LES SOURCES ELECTRIQUES INCLUANT LES DISJONCTEURS SITUES A DISTANCE AVANT D'EFFECTUER L'ENTRETIEN.
FAUTE DE DECONNECTER LA SOURCE ELECTRIQUE AVANT D'EFFECTUER L'ENTRETIEN PEUT ENTRAINDER DES BLESSURES CORPORELLES SEVERES OU LA MORT.

IMPORTANT
USE COPPER CONDUCTORS ONLY TO PREVENT EQUIPMENT DAMAGE.
UNIT TERMINALS ARE NOT DESIGNED TO ACCEPT ANY OTHER WIRING.

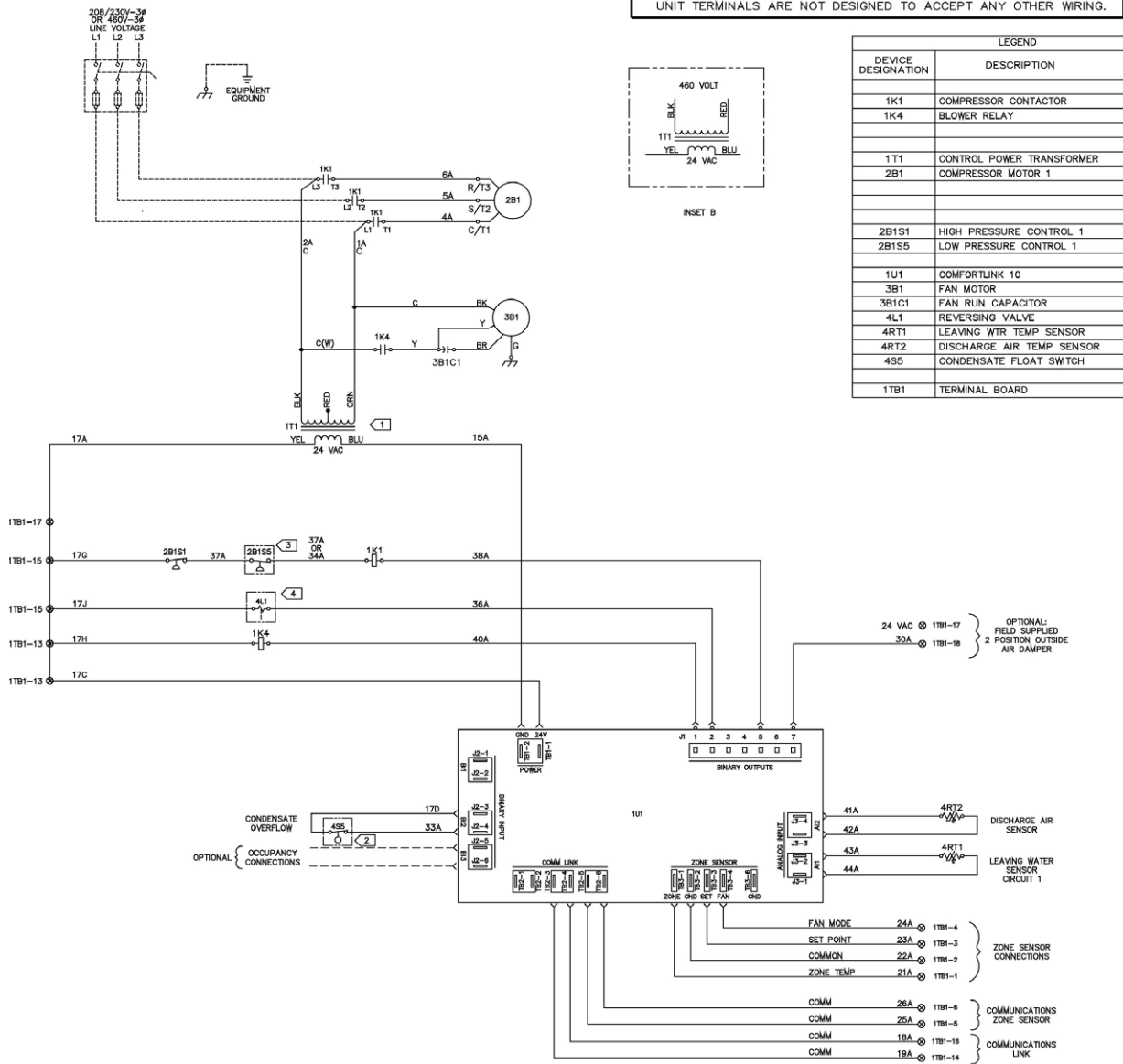

LEGEND	
DEVICE DESIGNATION	DESCRIPTION
1K1	COMPRESSOR CONTACTOR
1K4	BLOWER RELAY
1T1	CONTROL POWER TRANSFORMER
2B1	COMPRESSOR MOTOR 1
2B1S1	HIGH PRESSURE CONTROL 1
2B1S5	LOW PRESSURE CONTROL 1
1U1	COMFORTLINK 10
3B1	FAN MOTOR
3B1C1	FAN RUN CAPACITOR
4L1	REVERSING VALVE
4RT1	LEAVING WTR TEMP SENSOR
4RT2	DISCHARGE AIR TEMP SENSOR
4S5	CONDENSATE FLOAT SWITCH
1TB1	TERMINAL BOARD

- NOTES:**
- 1 TRANSFORMER (1T1) SHOWN IS WIRED FOR 230V, RED LEAD IS FOR 208V. SEE INSET "B" FOR 460V TRANSFORMER.
 - 2 CONDENSATE OVERFLOW SWITCH (4S5) IS OPTIONAL.
 - 3 LOW PRESSURE SWITCH (2B1S5) IS OPTIONAL.
 - 4 REVERSING VALVE (4L1) IS STANDARD ON HEAT PUMP ONLY.
 - 5 UNLESS OTHERWISE NOTED, ALL SWITCHES ARE SHOWN AT 25° C (77° F), AT ATMOSPHERIC PRESSURE, AT 50% RELATIVE HUMIDITY, WITH ALL UTILITIES TURNED OFF. AND AFTER A NORMAL SHUTDOWN HAS OCCURRED.
 - 6 DASHED LINES INDICATE RECOMMENDED FIELD WIRING BY OTHERS. DASHED LINE ENCLOSURES AND/OR DASHED DEVICE OUTLINES INDICATE COMPONENTS PROVIDED BY THE FIELD. PHANTOM LINE ENCLOSURES INDICATE ALTERNATE CIRCUITRY OR AVAILABLE SALES OPTIONS. SOLID LINES INDICATE WIRING BY TRANE CO.

Unit Wiring WPHF Tracer ZN510 Diagram

MOTOR SPEED TAP		
HIGH	MED	LOW
BLK	BLU	RED

FOR MED & LOW SPEED TIE BLACK & PURPLE ON 460V UNIT ONLY

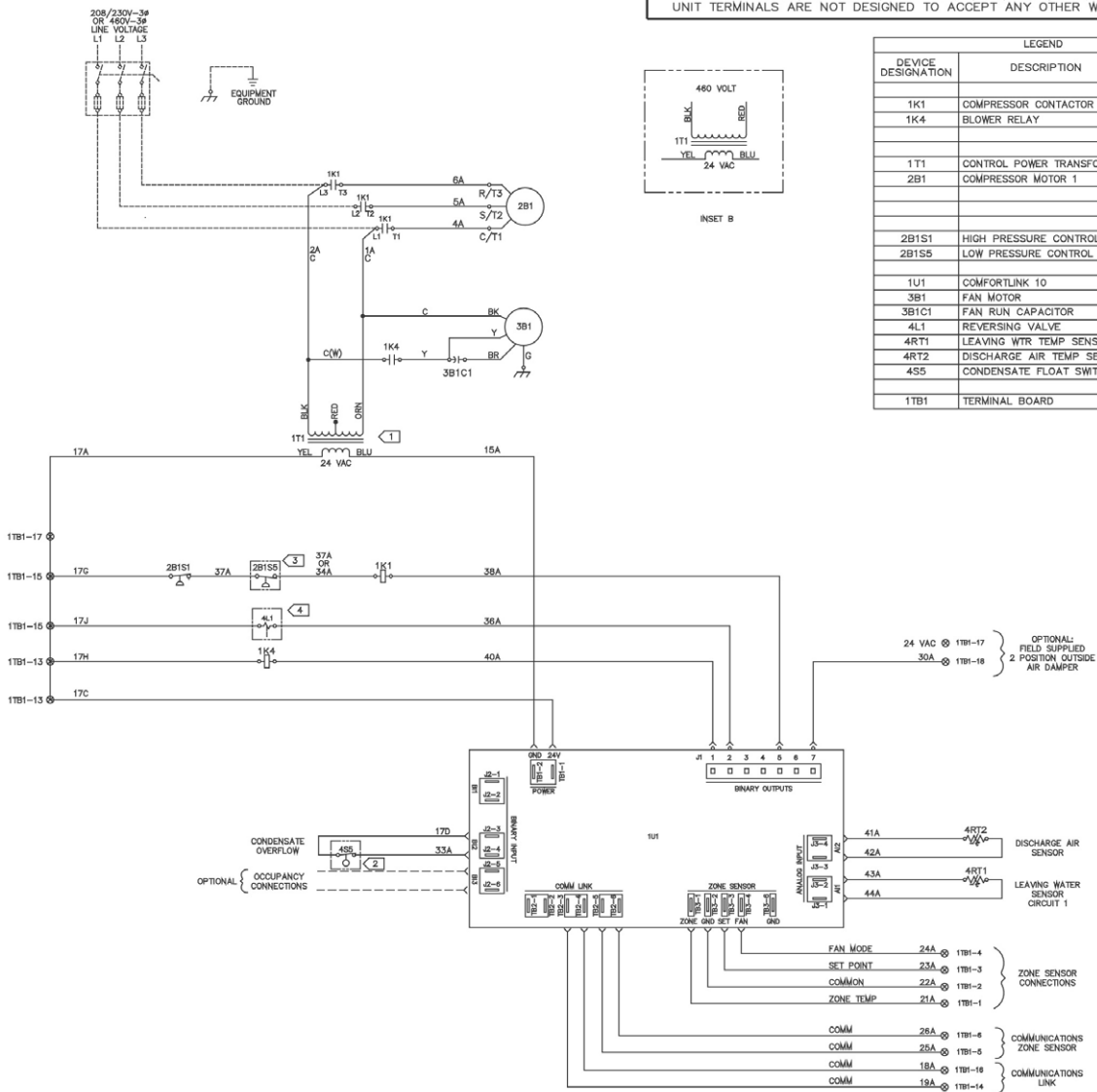

⚠ WARNING
HAZARDOUS VOLTAGE!
DISCONNECT ALL ELECTRIC POWER INCLUDING REMOTE DISCONNECTS BEFORE SERVICING.
FAILURE TO DISCONNECT POWER BEFORE SERVICING CAN CAUSE SEVERE PERSONAL INJURY OR DEATH.

⚠ AVERTISSEMENT
VOLTAGE HASARDEUX!
DECONNECTEZ TOUTES LES SOURCES ELECTRIQUES INCLUANT LES DISJONCTEURS SITUES A DISTANCE AVANT D'EFFECTUER L'ENTRETIEN.
FAUTE DE DECONNECTER LA SOURCE ELECTRIQUE AVANT D'EFFECTUER L'ENTRETIEN PEUT ENTRAINER DES BLESSURES CORPORELLES SEVERES OU LA MORT.

IMPORTANT
USE COPPER CONDUCTORS ONLY TO PREVENT EQUIPMENT DAMAGE. UNIT TERMINALS ARE NOT DESIGNED TO ACCEPT ANY OTHER WIRING.

LEGEND	
DEVICE DESIGNATION	DESCRIPTION
1K1	COMPRESSOR CONTACTOR
1K4	BLOWER RELAY
1T1	CONTROL POWER TRANSFORMER
2B1	COMPRESSOR MOTOR 1
2B1S1	HIGH PRESSURE CONTROL 1
2B1S5	LOW PRESSURE CONTROL 1
1U1	COMFORTLINK 10
3B1	FAN MOTOR
3B1C1	FAN RUN CAPACITOR
4L1	REVERSING VALVE
4RT1	LEAVING WTR TEMP SENSOR
4RT2	DISCHARGE AIR TEMP SENSOR
4S5	CONDENSATE FLOAT SWITCH
1TB1	TERMINAL BOARD

NOTES:

- 1 TRANSFORMER (1T1) SHOWN IS WIRED FOR 230V, RED LEAD IS FOR 208V. SEE INSET "B" FOR 460V TRANSFORMER.
- 2 CONDENSATE OVERFLOW SWITCH (4S5) IS OPTIONAL.
- 3 LOW PRESSURE SWITCH (2B1S5) IS OPTIONAL.
- 4 REVERSING VALVE (4L1) IS STANDARD ON HEAT PUMP ONLY.
- 5 UNLESS OTHERWISE NOTED, ALL SWITCHES ARE SHOWN AT 25° C (77° F), AT ATMOSPHERIC PRESSURE, AT 80% RELATIVE HUMIDITY, WITH ALL UTILITIES TURNED OFF, AND AFTER A NORMAL SHUTDOWN HAS OCCURRED.
- 6 DASHED LINES INDICATE RECOMMENDED FIELD WIRING BY OTHERS. DASHED LINE ENCLOSURES AND/OR DASHED DEVICE OUTLINES INDICATE COMPONENTS PROVIDED BY THE FIELD. PHANTOM LINE ENCLOSURES INDICATE ALTERNATE CIRCUITRY OR AVAILABLE SALES OPTIONS. SOLID LINES INDICATE WIRING BY TRANE CO.



TRANE[®]

Trane
A business of American Standard Companies
www.trane.com

Literature Order Number	WSHP-SVX04A-EN
File Number	SV-UN-WSHP-SVX04A-0803
Supersedes	WSHP-IOM-1, WPVF-IOM-1
Stocking Location	Inland

For more information, contact your local district office or e-mail us at comfort@trane.com

Trane has a policy of continuous product and data improvement and reserves the right to change design and specifications without notice.

Free Manuals Download Website

<http://myh66.com>

<http://usermanuals.us>

<http://www.somanuals.com>

<http://www.4manuals.cc>

<http://www.manual-lib.com>

<http://www.404manual.com>

<http://www.luxmanual.com>

<http://aubethermostatmanual.com>

Golf course search by state

<http://golfingnear.com>

Email search by domain

<http://emailbydomain.com>

Auto manuals search

<http://auto.somanuals.com>

TV manuals search

<http://tv.somanuals.com>