

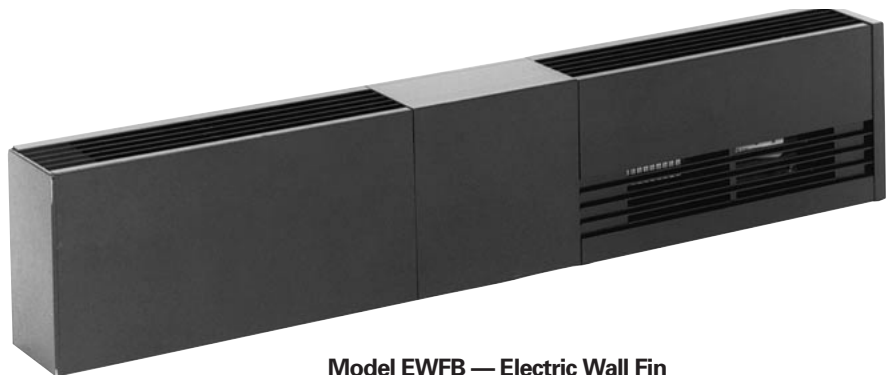

Electric Wall Fin



Model EWFB — Electric Wall Fin

October 2001

FIN-PRC003-EN



Features and Benefits

Model EWFB Electric Wall Fin

Trane electric natural convection heavy duty wall fin has been designed to be securely attached to the wall or as an option floor mounted on pedestals. Trane wall fin is ideally suited as a primary heating source, a supplement in high heat loss areas or as a draft barrier to help minimize cold wall and window conditions. Because of its rugged construction, wall fin is especially recommended for public areas in commercial and institutional applications such as offices, schools, hospitals, transportation terminals, churches, dormitories and nursing homes.

The range of sizes and heat outputs can be individually combined to form a truly custom comfort system. The wide variety of colors, materials and accessories become architecturally compatible with any interior concept and design.

Enclosure Options

- Enclosures ranging from 2 ⁵/₈" (67 mm), 3 ¹/₂" (89 mm), 5" (127 mm) and 5 ¹/₂" (140 mm) depths and 4" (102 mm), 4 ¹/₂" (114 mm), 6" (152 mm), 7" (178 mm) heights. Model ASHDB is available in 8" (203 mm) through 20" (508 mm) heights.
- Front intake models may be installed directly on finished floors.
- 2' (.61 M) to 15' (4.57 M) lengths.
- ¹/₄" (6.4 mm) pencil-proof top discharge extruded aluminum grilles and extruded aluminum back.
- One-piece front and top panel snap fits to back cover for two-piece construction.
- Totally-enclosed junction boxes.
- Full length thermal overload protection.
- Bonded aluminum fins for cool surface temperatures.
- Standard ¹/₂" (13 mm) EMT raceway between junction boxes.
- Thermostats single or double-pole.
- Disconnect switch, double-pole.
- Transformer relay single-pole and power relays.
- Custom lengths to 1' (4.57 M).
- 6" (152 mm) and 12" (305 mm) control sections for factory mounting of one to two controls.
- Extended enclosures extend heater's length in 6" (152 mm) increments to a maximum length of 60" (1524 mm).
- Blank enclosure sections for all models to allow branch circuit wiring. Can be modified for use with hydronic heating elements.
- Full line of field adjustable accessories for virtually perfect wall-to-wall or mullion-to-mullion fit without field cutting. Approved as 40 ampere wireways.
- UL Listed.
- ¹/₄" (6.4 mm) wire mesh, factory installed on enclosure.
- No visible mounting screws.
- Pedestal brackets available for floor mounting in lobbies or in front of windows.



DBT — Wall Mount (Bottom Inlet)

3 ¹/₂" Deep x 6" High — 12-Gauge Extruded Aluminum Front and Grille

DBF — Floor Mount (Front Inlet) for zero clearance mounting



CB — Wall Mount (Bottom Inlet)

2 ⁵/₈" Deep x 4 ¹/₂" High — 14-Gauge Extruded Aluminum Front and Grille

Contents

Features and Benefits

2

Dimensional Data

4

Wiring Diagrams

9

Mechanical Specifications

14



DBCT — Bottom Inlet (Top Discharge)
DBCF — Front Inlet (Top Discharge)
 5" Deep x 7" High — 10-Gauge Extruded
 Aluminum Front and Grille



RDBT-PD Architectural Draft Barrier
 6" Deep x 5" High — 12-Gauge Extruded
 Pedestal Mount



ASHDB — 8 through 20
 5 1/2" Deep x 8" thru 20" High
 Front Cover 16-Gauge Steel with
 12-Gauge Extruded Aluminum Grille

Dimensional Data

Model EWFB

Type DBF Wall Mounted (Bottom Louver) 15' (4.57 M) Length DBF and DBT Only Wall Mounted

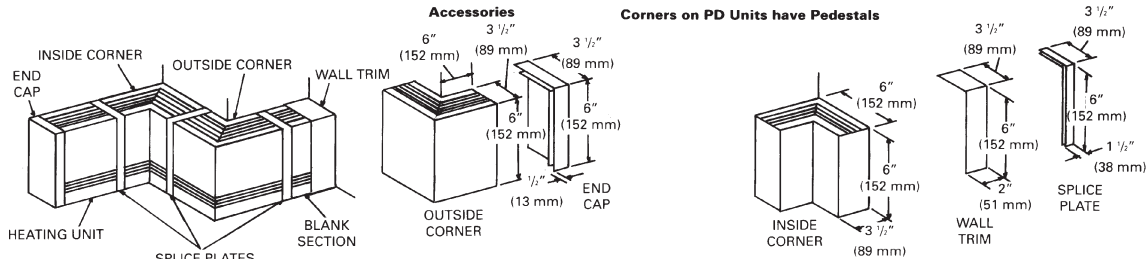
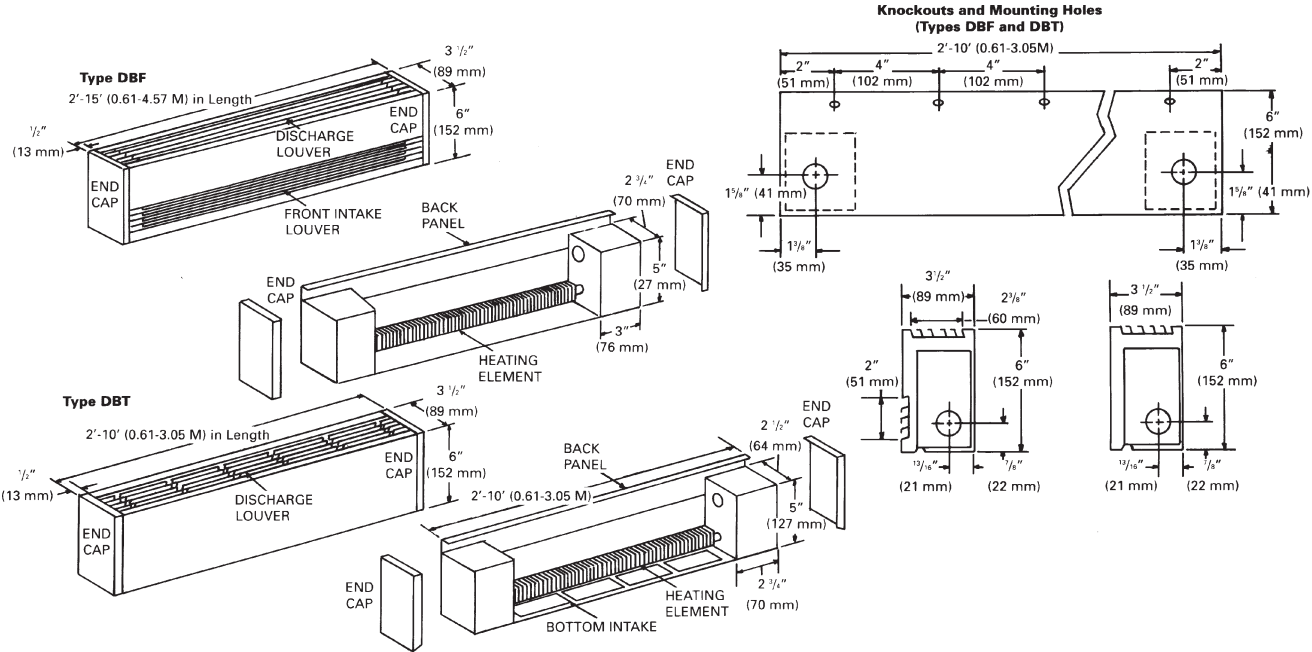

Architectural Pedestal Heaters Series DBT and DBF 100-250 Watt Per Foot

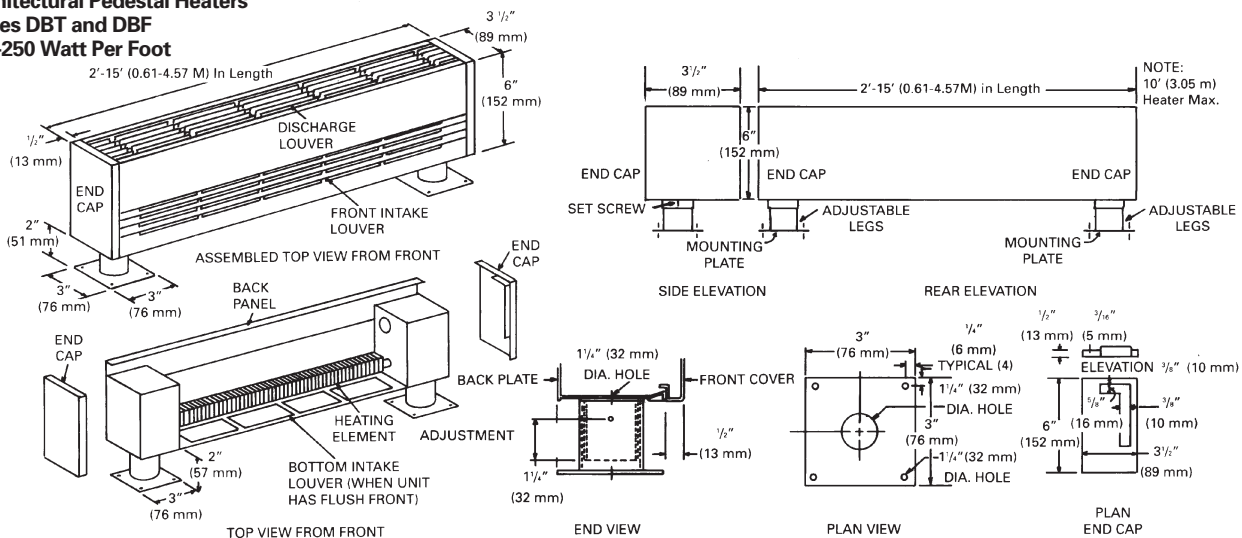

Dimensional Data

Model EWFB

Type CB Wall Mounted

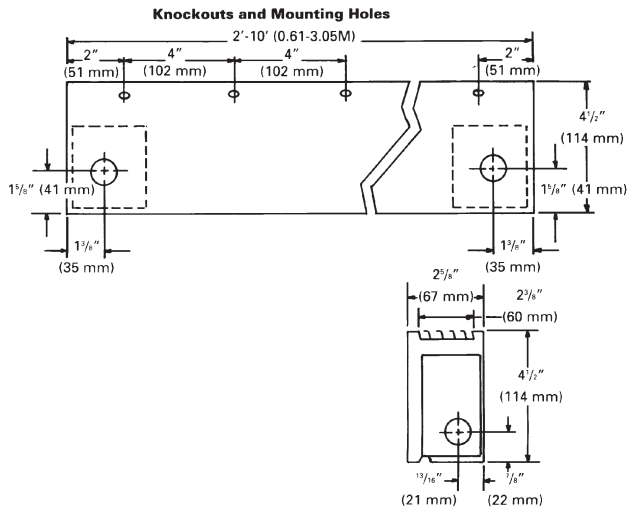
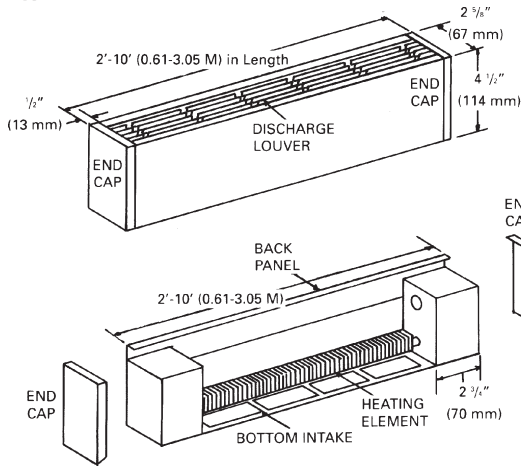

Typical Installation

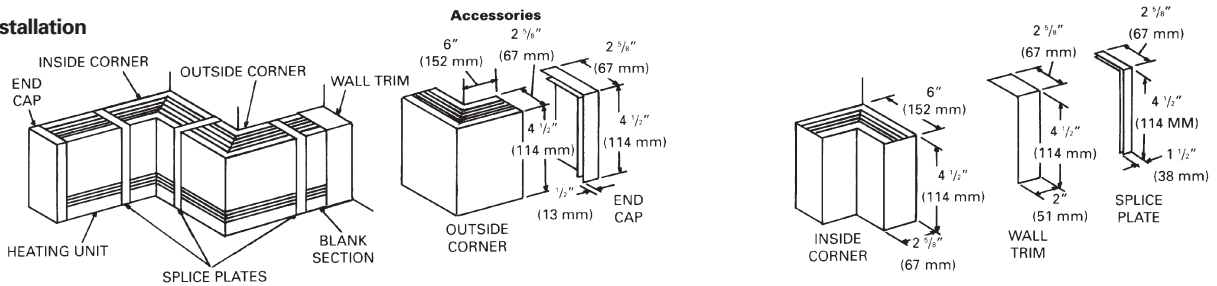

Pedestal Heaters – Series CB 250 Watts Per Foot – Element Pedestals

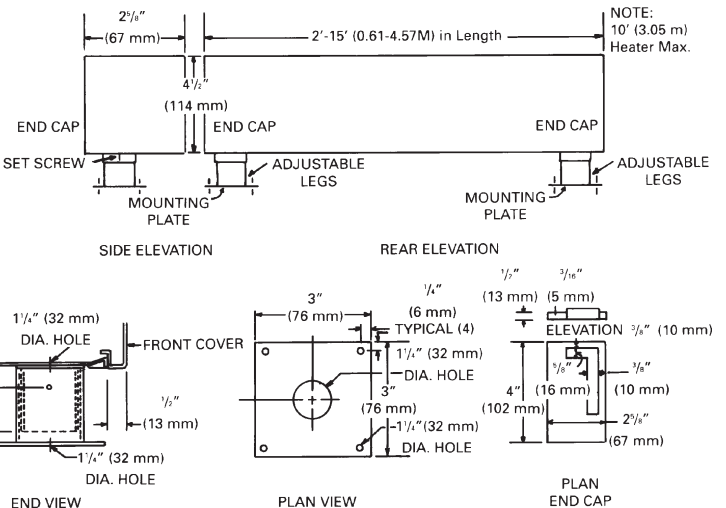
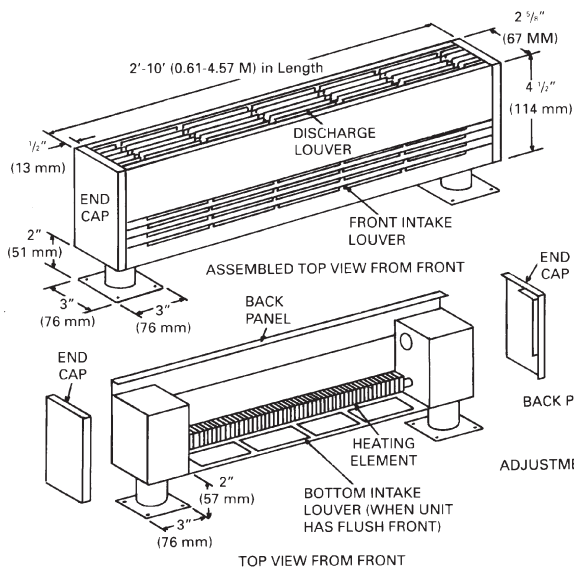

Dimensional Data

Model EWFB

Type DBCT and DBCF (Bottom Louver) Wall Mounted

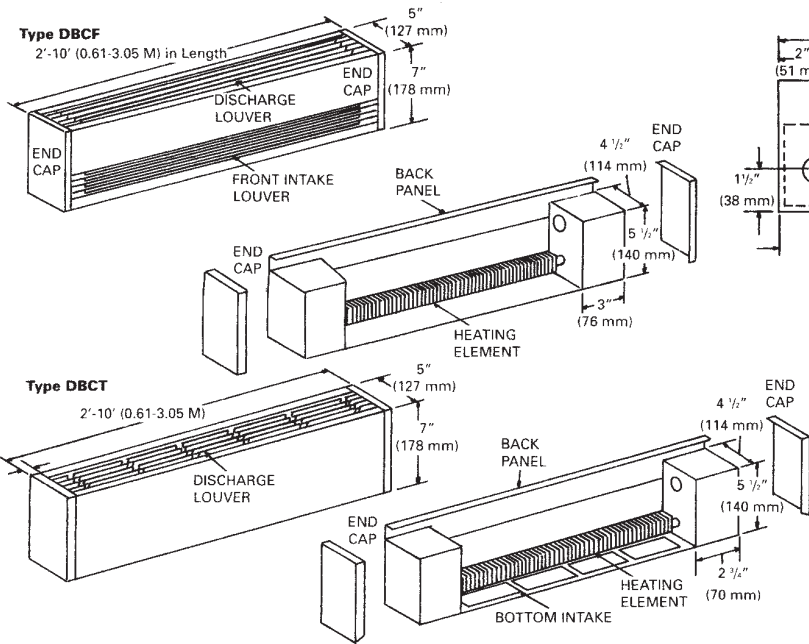

Knockouts and Mounting Holes

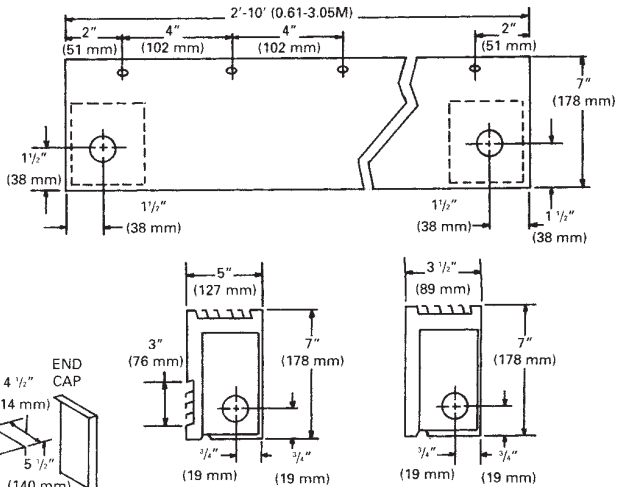

NOTE:
Front covers available as standard through 15'.
Backplate available as option through 15'.

Typical Installation

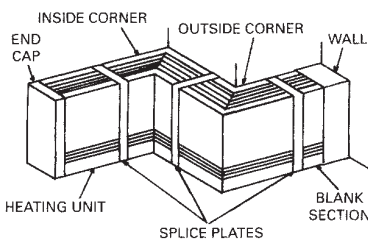

Accessories

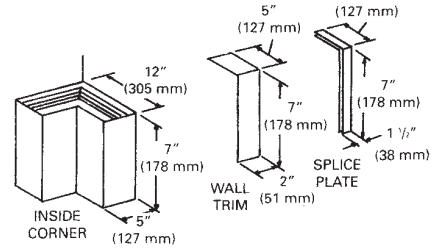
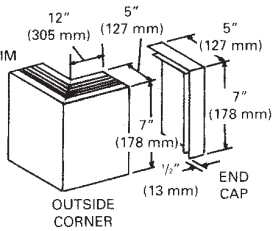

Architectural Pedestal Heaters Series DBCF, DBCT

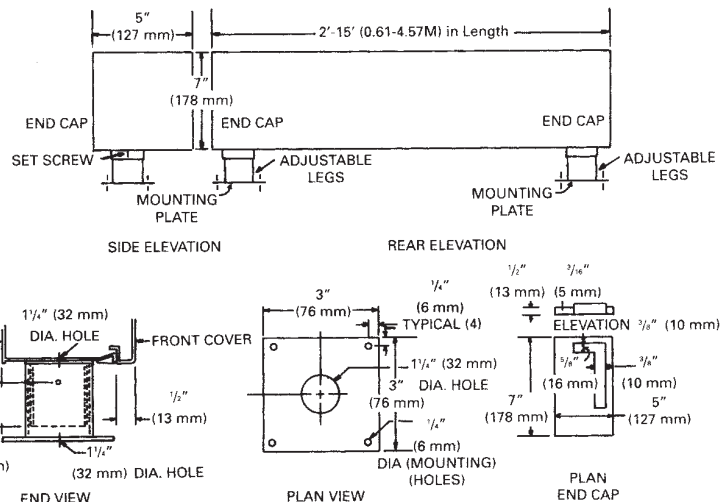
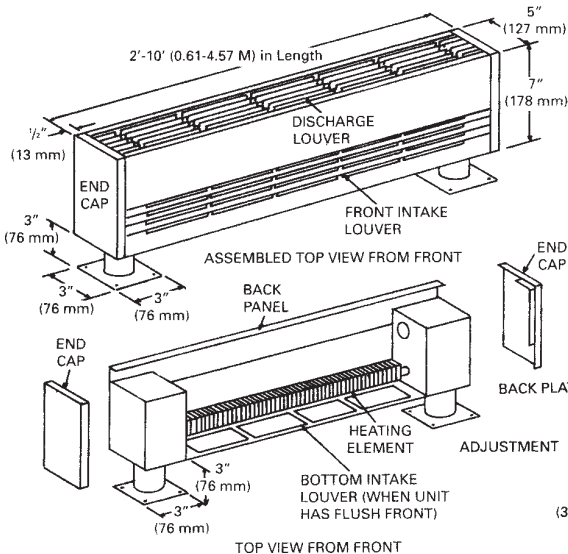

Dimensional Data

Model EWFB

Model RDBT-PD Pedestal Floor Mounted

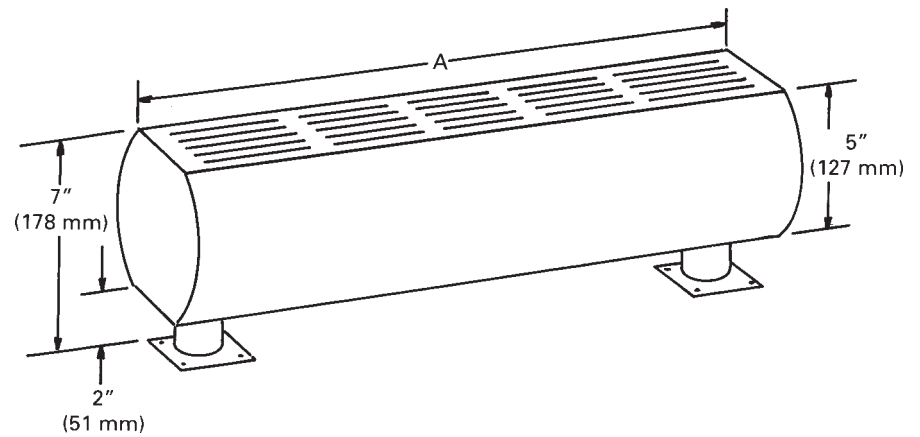

Unit Length

Dimension "A"	Dimension "A"
Feet	Meters
2 Ft.	0.61
3 Ft.	0.91
4 Ft.	1.22
5 Ft.	1.52
6 Ft.	1.83
7 Ft.	2.13
8 Ft.	2.44
9 Ft.	2.74
10 Ft.	3.05

Dimensional Data

Model EWFB

Type ASHDB-8 thru 20 Wall Mounted Knockouts and Mounting Holes

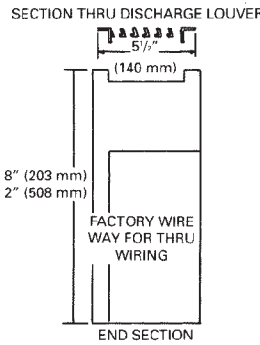
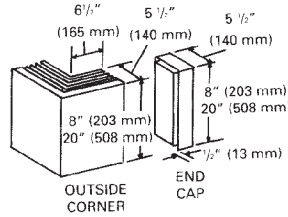
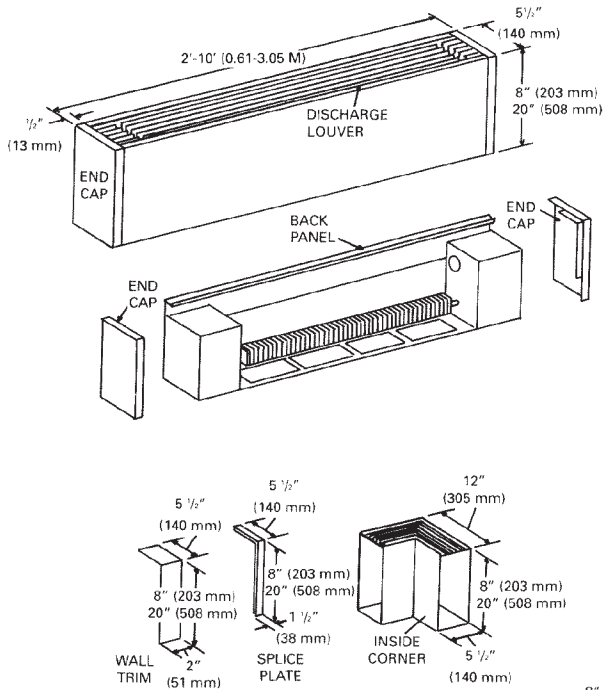

Typical Installation

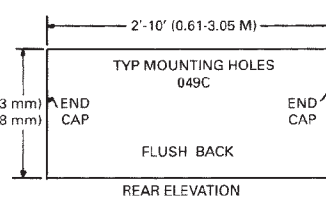
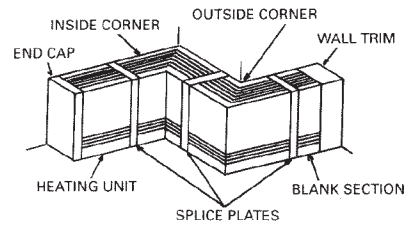

*Architectural Pedestal Heaters – Series ASHDB-8 8" High 100-500 Watts Per Foot

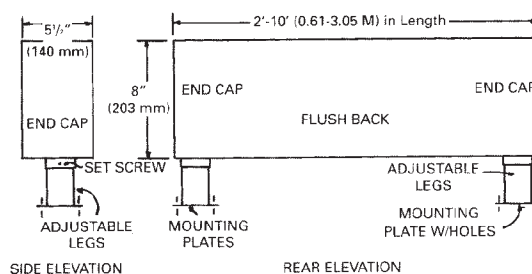
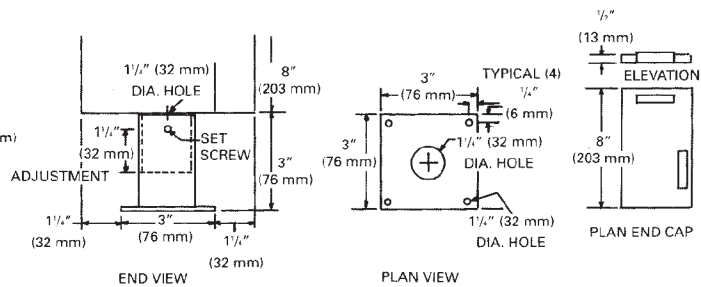
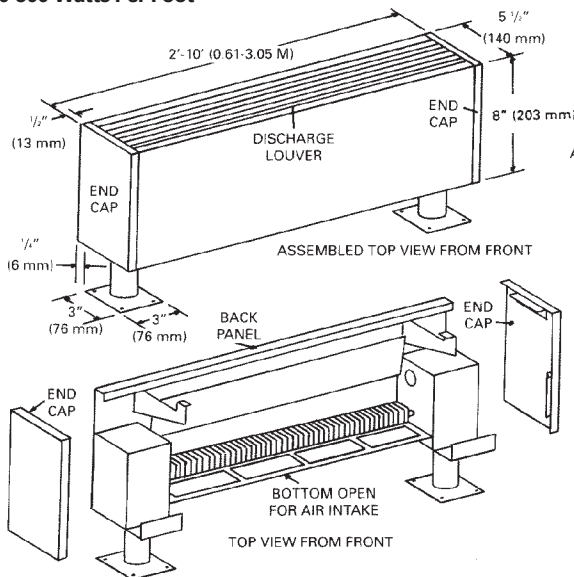

*8" high ASHDB unit is the only size that can be mounted on pedestals.

Wiring Diagrams

Model EWFB

Controls

Description — Single Pole

Catalog Number – DBF-ITS, DBT-ITS, CDF-ITS, CDT-ITS

Rated 25 amps at 120-277 VAC. 50-110°F temperature range. Tamperproof and adjustable through discharge louver.

Description – Double Pole Thermostat

Catalog Number – DBF-ITD, DBT-ITD, CDF-ITD, CDT-ITD

Rated 25 amps at 120-277 VAC. 50-110°F temperature range. Tamperproof and adjustable through discharge louver.

Description – Disconnect Switch

Catalog Number – DBF-IDS, DBT-IDS, CDF-IDS, CDT-IDS

Double pole rated 20 amps at 120-277 VAC.

Field Wiring With Integral Controls

- Integral thermostats: wire entry from either end.
- Disconnect switch: right hand wire entry.
- Thermostat and disconnect: right hand wire entry.
- Relays: right hand wire entry – control section.
- Thermostat – disconnect and relay: right hand wire entry – control section.

When heaters are furnished with controls, make certain that the heater or heaters do not exceed the lowest amperage rating of the controls furnished. For example, if a thermostat and disconnect are furnished, the thermostat is rated at 25 amps 240 and 277, the disconnect is rated 20 amps 240 and 277. Therefore, the combination of heaters should not exceed 20 amps at 277 or 240.

Wiring Diagrams

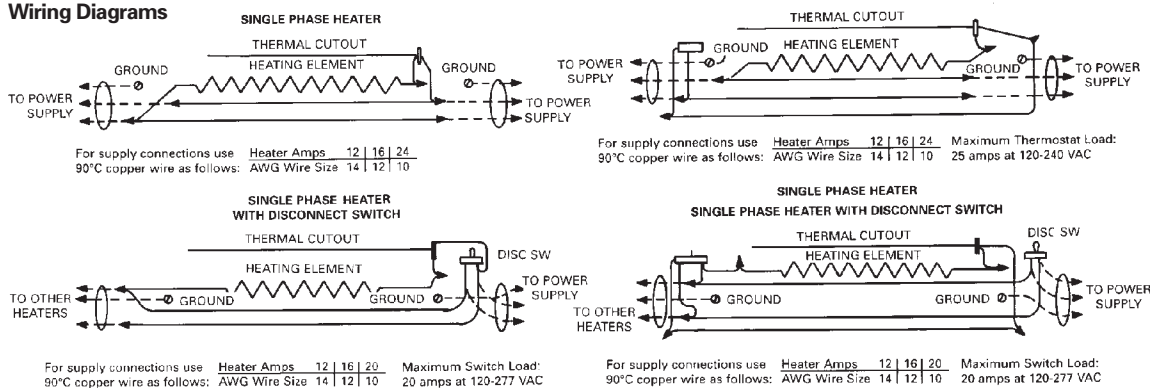

Wiring Diagrams – Control Section

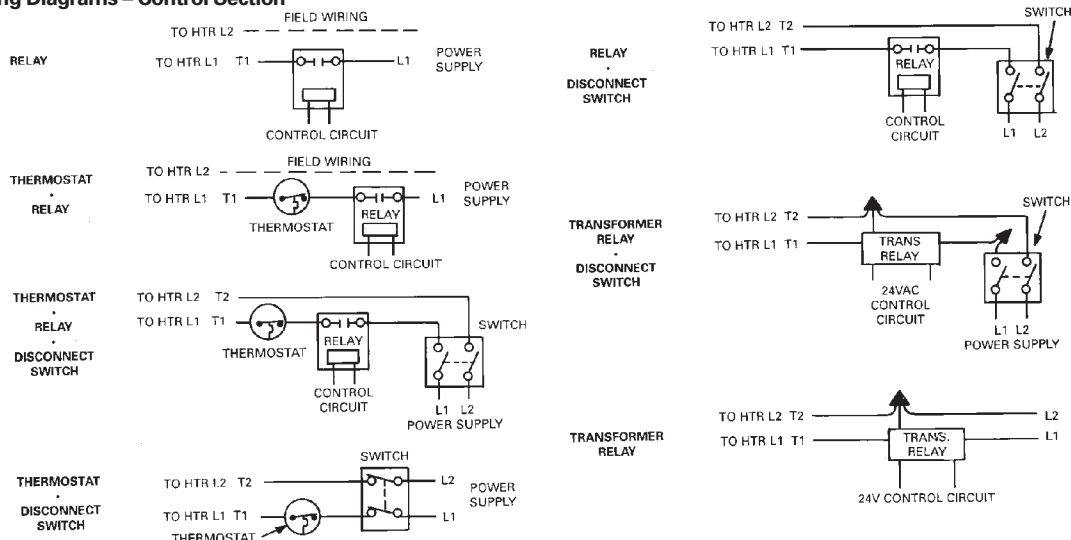

Wiring Diagrams

Model EWFB

Controls

Description – Single Pole
Catalog Number – CB-ITS

Rated 25 amps at 120-277 VAC. 50-110°F temperature range. Tamperproof and adjustable through discharge louver.

Description – Double Pole Thermostat
Catalog Number – CB-ITD

Rated 25 amps at 120-277 VAC. 50-110°F temperature range. Tamperproof and adjustable through discharge louver.

Description – Disconnect Switch
Catalog Number – CB-IDS

Double pole rated 20 amps at 120-277 VAC.

Field Wiring With Integral Controls

- Integral thermostats: wire entry from either end.
- Disconnect switch: mount either end.
- Thermostat and disconnect: mount either end.
- Relays: control section.
- Thermostat – disconnect and relay: control section

Note: Control section is attached on either side.

When heaters are furnished with controls, make certain that the heater or heaters do not exceed the lowest amperage rating of the controls furnished. For example, if a thermostat and disconnect are furnished, the thermostat is rated at 25 amps 240 and 277, the disconnect is rated 20 amps 240 and 277 VAC. Therefore, the combination of heaters should not exceed 20 amps at 277 or 240 VAC.

Wiring Diagrams

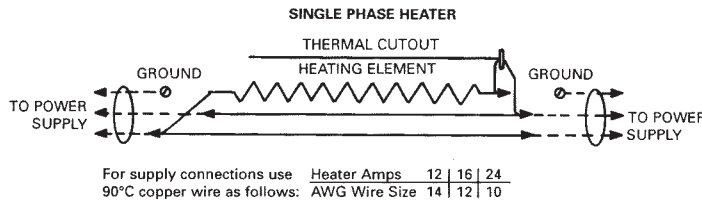

Wiring Diagrams – Control Section

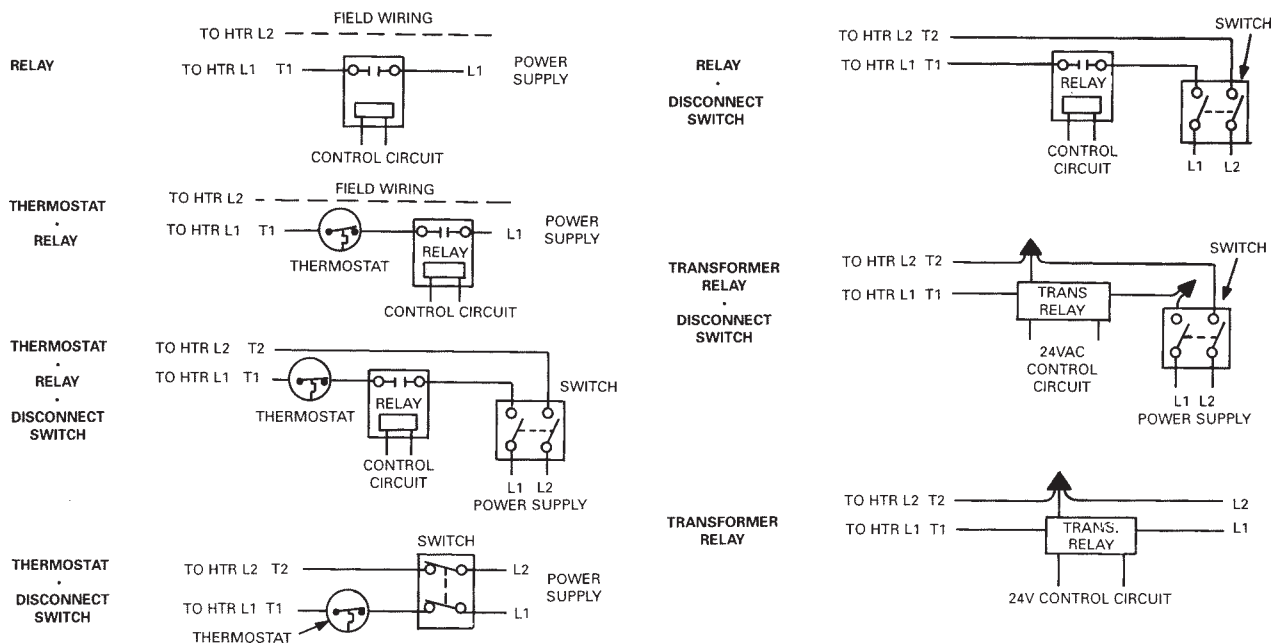

Wiring Diagrams

Model EWFB

Controls

Description – Single Pole

Catalog Number – DBCF-ITS, DBCT-ITS
 Rated 25 amps at 120-277 VAC. 50-110°F temperature range. Tamperproof and adjustable through discharge louver.

Description – Double Pole Thermostat

Catalog Number – DBCF-ITD, DBCT-ITD
 Rated 25 amps at 120-277 VAC. 50-110°F temperature range. Tamperproof and adjustable through discharge louver.

Description – Disconnect Switch

Catalog Number – DBCF-IDS, DBCT-IDS
 Double pole rated 20 amps at 120-277 VAC.

Field Wiring With Integral Controls

- Integral thermostats: wire entry from either end.
- Disconnect switch: right hand wire entry.
- Thermostat and disconnect: right hand wire entry.
- Relays: right hand wire entry – control section.
- Thermostat – disconnect and relay: right hand wire entry – control section.

When heaters are furnished with controls, make certain that the heater or heaters do not exceed the lowest amperage rating of the controls furnished. For example, if a thermostat and disconnect are furnished, the thermostat is rated at 25 amps 240 and 277, the disconnect is rated 20 amps 240 and 277. Therefore, the combination of heaters should not exceed 20 amps at 277 or 240.

Wiring Diagrams

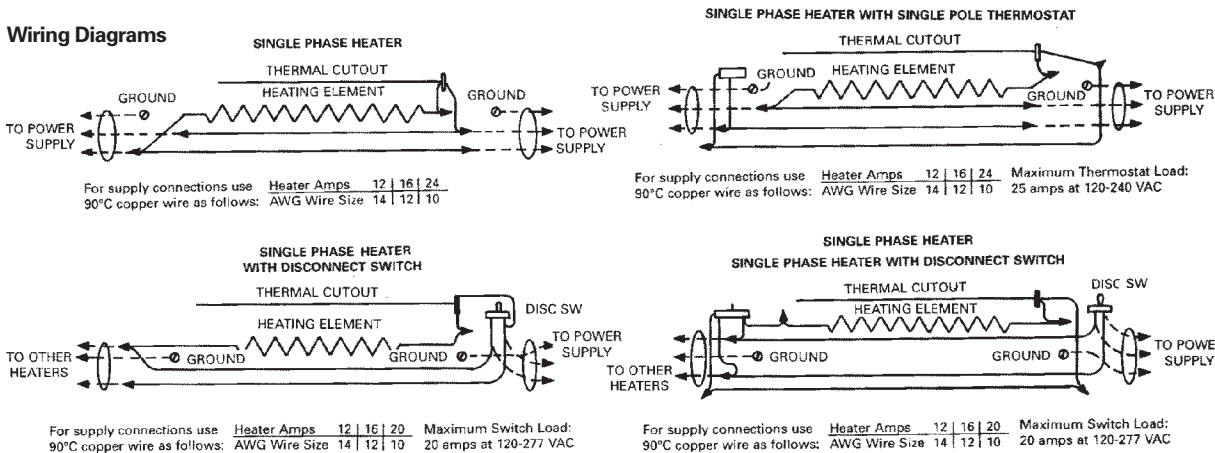

Wiring Diagrams – Control Section

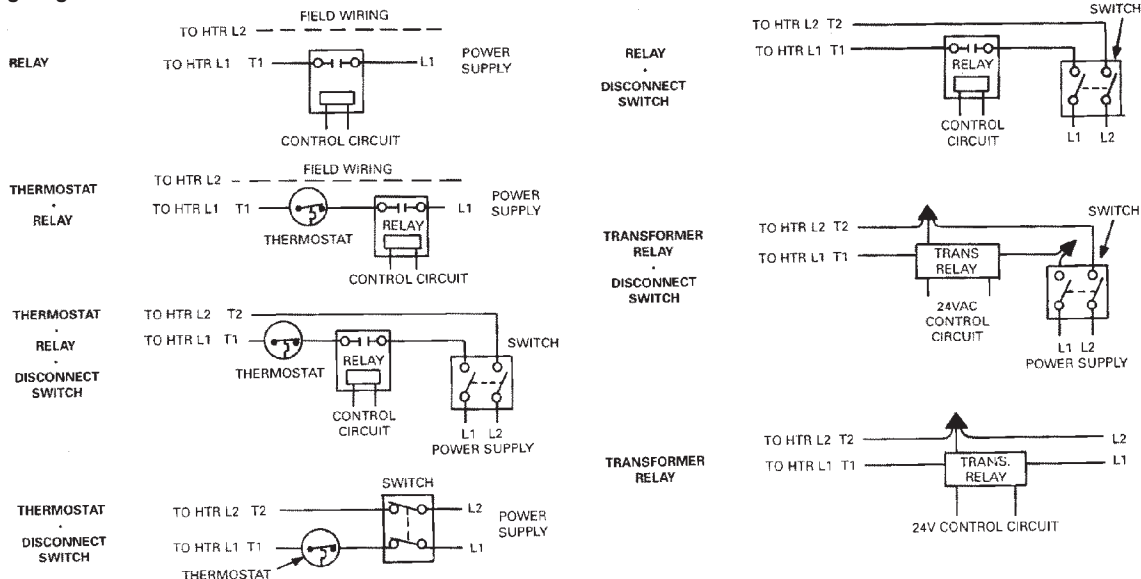

Wiring Diagrams

Model EWFB

Controls

Description – Single Pole

Catalog Number – RDBT-ITS

Rated 25 amps at 120-277 VAC. 50-110°F temperature range. Tamperproof and adjustable through discharge louver.

Description – Double Pole Thermostat

Catalog Number – RDBT-ITD

Rated 25 amps at 120-277 VAC. 50-110°F temperature range. Tamperproof and adjustable through discharge louver.

Description – Disconnect Switch

Catalog Number – RDBT-IDS

Double pole rated 20 amps at 120-277 VAC.

Field Wiring With Integral Controls

- Integral thermostats: wire entry from either end.
- Disconnect switch: right hand wire entry.
- Thermostat and disconnect: right hand wire entry.
- Relays: right hand wire entry – control section.
- Thermostat – disconnect and relay: right hand wire entry – control section.

When heaters are furnished with controls, make certain that the heater or heaters do not exceed the lowest amperage rating of the controls furnished. For example, if a thermostat and disconnect are furnished, the thermostat is rated at 25 amps 240 and 277 VAC, the disconnect is rated 20 amps 240 and 277 VAC. Therefore, the combination of heaters should not exceed 20 amps at 277 or 240 VAC.

Wiring Diagrams

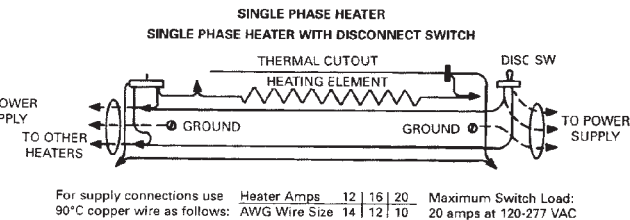
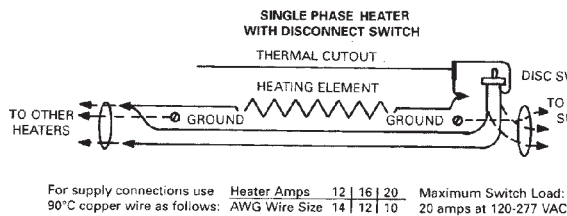
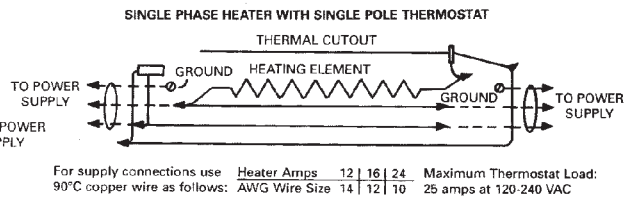
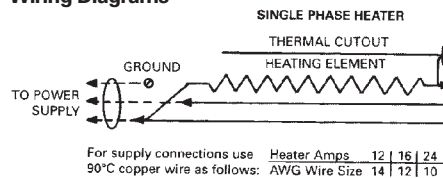

Wiring Diagrams – Control Section

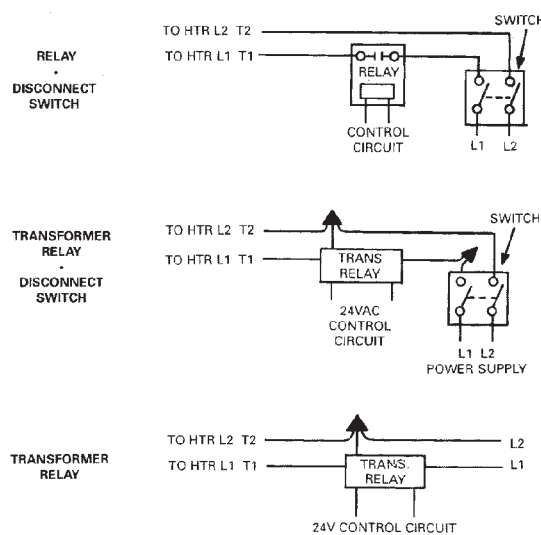
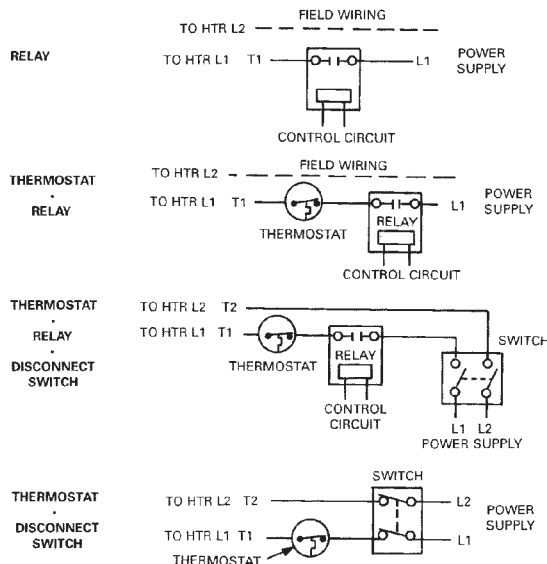

Wiring Diagrams

Model EWFB

Catalog Number ASHDB
Heaters Over 5' (1.52 M) Long May Have Two Heating Elements
Wiring Diagram – Heater Only

Wiring Diagrams

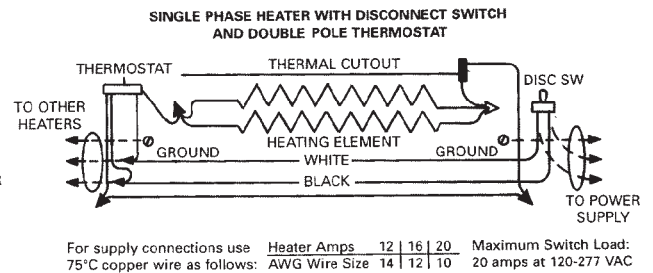
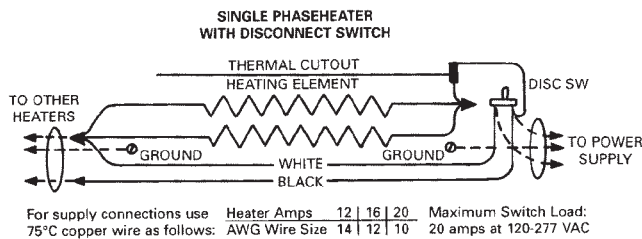
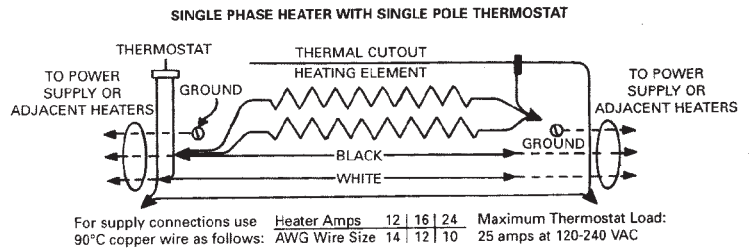
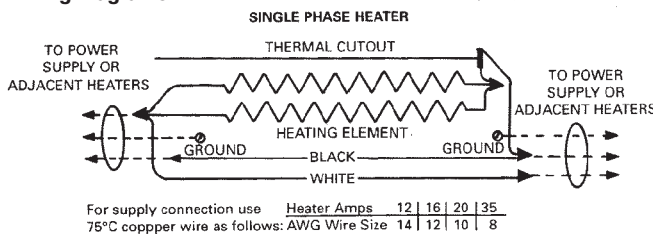

NOTE: On 277volt white wire is neutral.

Wiring Diagrams – Control Section

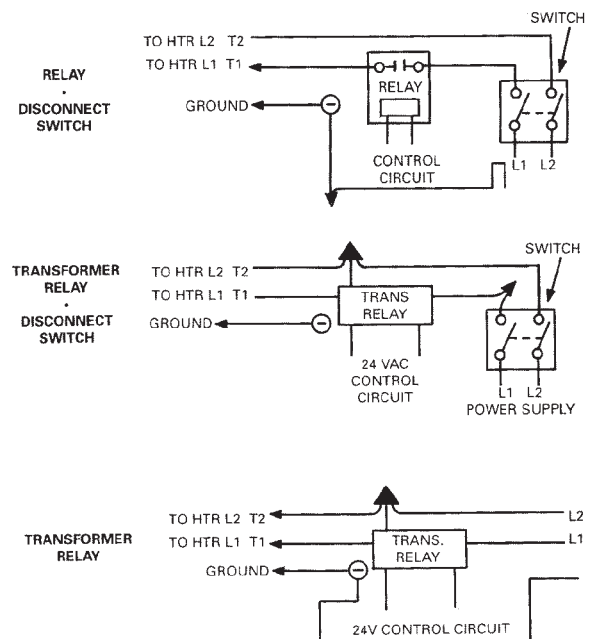
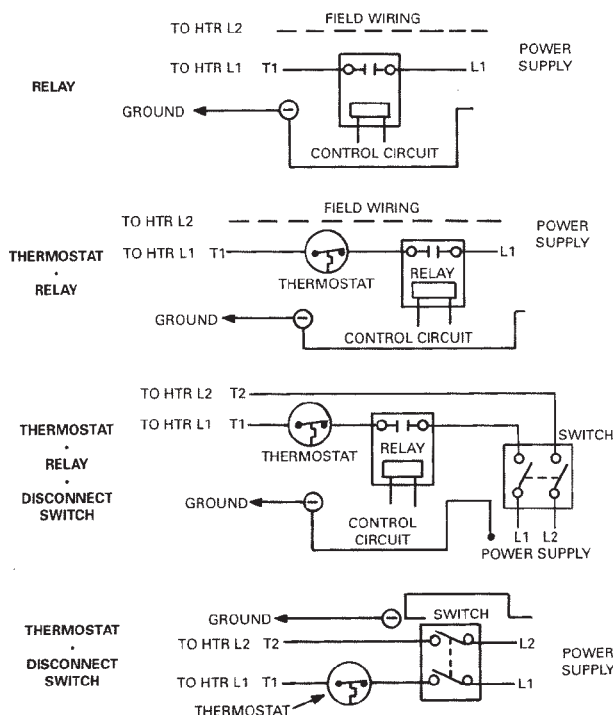

NOTE: On 277volt white wire is neutral.



Mechanical Specifications

Model EWFB

Specifications

Natural convection heavy-duty electric wall fin are furnished to meet the specified wattage, voltage and size. Units installed and wired in accordance with the manufacturer's recommendations and applicable national and local codes.

Mounting: Electric wall fin heaters designed to be securely attached to the wall (or optional floor mounted on pedestals) per manufacturer's instructions. Heaters are wired for either right or left hand entry where there are no controls, otherwise entry will be in the junction box containing controls.

Heaters with bottom air intake and top air exit and front air intake (inlet grille) and top air exit (both wall and pedestal styles) must be mounted a minimum of 3" (76 mm) off the finished floor.

Heaters with front air intake (inlet grille) and top air exit can be wall mounted at the finished floor level and are approved for zero clearance at the bottom.

Heater Design: Units are of modern square design, constructed of specified materials and contain totally enclosed junction boxes at both ends, aluminum fin tube element(s), thermal overload and a 1/2" (13 mm) EMT prewired 40 ampere wireway. Heater lengths furnished in 2 foot (0.6 M) through 10 foot (3.0 M) in 1 foot (0.3 M) increments. 1/2" (13 mm) and 3/4" (19 mm) knockouts are provided on the side and rear of the heaters junction box to allow end to end wiring for wall mounted units and in the bottom of the junction box only for floor mounted heaters.

Enclosure front panel are of one piece construction suitable for architectural, commercial and industrial use, with 1/4" (6.4 mm) pencil-proof top air discharge and or front air intake louvers. Louvers discharge heated air at a 15 degree angle for cleaner operation. The one-piece front panel is extruded for maximum strength and is available in

lengths to 15 feet (4.6 M). Front panel snap fit to the back panel with out fasteners for two-piece construction. Back panel is pre-punched for easy installation and is suitable for mullion to mullion installation for wall mounted heaters only.

Extended Enclosures: Are manufactured with solid metal grilles and extends the enclosure length another 6" (152 mm), 12" (305 mm), 18" (457 mm), 24" (610 mm), 30" (762 mm), 36" (914 mm), 42" (1067 mm), 48" (1219 mm), 54" (1372 mm) and 60" (1524 mm). Heater and Extended Enclosure are furnished as a one piece unit. Used to factory mount 6" (152 mm) and 12" (305 mm) Control Sections. Left or right hand mounting of the Control Section must be specified. Maximum Length with Extended Enclosures are 15 feet (4.6 M) for heater models DBT, DBF and CB, 12 feet (3.7 M) for heater models DBCT, DBCF and RDBT-PD and 10 feet (3.04 M) for heater model ASHDB.

Mechanical Specifications

Model EWFB

Enclosure Models and Type:

- **Model DBT** – Wall mounted (bottom air inlet and top air outlet) are snap fit two-piece construction, 6" (152 mm) high x 3 1/2" (89 mm) deep manufactured from 12-gauge (2.7 mm thickness) extruded aluminum. Extrusion is .100" (2.5 mm) thick 6063 aluminum heat treated to T-5 hardness. Backplates are 12-gauge (2.7 mm thickness) extruded aluminum. Maximum wattage is 300 watts per foot (984 watts per meter).
- **Model DBF** – Wall mounted (bottom front air inlet grille and top air outlet) is snap fit two-piece construction, 6" (152 mm) high x 3 1/2" (89 mm) deep manufactured from 12-gauge (2.7 mm thickness) extruded aluminum. Extrusion is .100" (2.5 mm) thick 6063 aluminum heat treated to T-5 hardness. Backplates are 12-gauge (2.7 mm thickness) extruded aluminum for zero clearance mounting. Maximum wattage is 250 watts per foot (820 watts per meter).
- **Model CB** – Wall mounted (bottom air inlet and top air outlet) are snap fit two-piece construction, 4 1/2" (114 mm) high x 2 5/8" (67 mm) deep manufactured from 14-gauge (1.9 mm thickness) extruded aluminum. Extrusion is .70" (1.8 mm) thick 6063 aluminum heat treated to T-5 hardness. Backplates are 14-gauge (1.9 mm thickness) extruded aluminum. Maximum wattage is 250 watts per foot (820 watts per meter).
- **Model DBCT** – Wall mounted (bottom air inlet and top air outlet) are snap fit two-piece construction, 7" (178 mm) high x 5" (127 mm) deep manufactured from 10-gauge (3.4 mm thickness) extruded aluminum. Extrusion is .100" (2.5 mm) thick 6063 aluminum heat treated to T-5 hardness. Backplates are 10-gauge (3.4 mm thickness) extruded aluminum. Maximum wattage is 750 watts per foot (2460 watts per meter).
- **Model DBCF** – Wall mounted (front air inlet grille and top air outlet) are snap fit two-piece construction, 7" (178 mm) high x 5" (127 mm) deep manufactured from 10-gauge (3.4 mm thickness) extruded aluminum. Extrusion is .100" (2.5 mm) thick 6063 aluminum heat treated to T-5 hardness. Backplates are 10-gauge (3.4 mm thickness) extruded aluminum. Maximum wattage is 650 watts per foot (2133 watts per meter).
- **Model RDBT-PD** – Pedestal mounted (bottom air intake and top air outlet) enclosure are rounded with a flat top air discharge, 5" (127 mm) high x 6" (152 mm) deep manufactured from 12-gauge (2.7 mm) thick extruded aluminum. Extrusion is .100" (2.5 mm) thick heat treated to T-5 hardness. Pedestals are 2" (51 mm) high for overall height of 7" (178 mm) from the floor to the top of the enclosure. Maximum wattage is 300 watts per foot (984 watts per meter).
- **Model ASHDB** – Wall mounted (bottom air inlet and top air outlet) are available in 8" (203 mm), 10" (254 mm), 12" (305 mm), 14" (356 mm), 16" (406 mm) 18" (457 mm) and 20" (508 mm) heights in a 5 1/2" (140 mm) depth. Enclosure front and back panel are manufactured from 16-gauge (1.5 mm thickness) steel and is snap fit two-piece construction. Discharge grille is 12-gauge (2.7 mm thickness) one piece continuous extruded aluminum, .100" (2.5 mm) thick 6063 aluminum heat treated to T-5 hardness. Maximum wattage is 500 watts per foot (1640 watts per meter).



Mechanical Specifications

Model EWFB

Heating Elements: Element(s) consist of high quality nickel chromium alloy resistance wire embedded and completely surrounded by magnesium oxide, enclosed and swaged in an aluminum sheath. Aluminum fins are mechanically bonded to the sheath for efficient heat transfer. The element fin temperature will not exceed 330°F (166°C) to help assure long element life. The heating element is center anchored and free floating at each end on nylon bushings for quiet operation.

Thermal Overload: A full length tubular automatic reset thermal overload disconnects the heating element(s) in the event normal operating temperatures are exceeded.

Volts/Phase: All models available in the following volts and phase 208/1, 240/1, 277/1 or 120/1.

Control Options: Built-in thermostat and disconnect are rated for 20 amps, 120-277 VAC. Transformer relay are rated 25 amp, 120-277 VAC and power relays rated for 18 amps. They are factory installed with one device per junction box or a 6" (152 mm) long or 12" (305 mm) long control section can be used due to the heaters size or more than two controls are required per heater.

- ITS – Single pole thermostat, 20 amp, is adjustable thru discharge grille factory mounted and wired in left hand junction box.
- ITD – Double pole thermostat, 20 amp, is adjustable thru discharge grille factory mounted and wired in left hand junction box.
- IDS – Double pole disconnect switch, 20 amp, is adjustable thru discharge grille factory mounted and wired in right hand junction box.

- ATR – Transformer relay single pole, rated 25 amp 120-277 VAC contacts rated up thru 277 volt and must be specified. Coils are 24 volt and 120 volt and must be specified.
- PR 208/24, 18 amp power relay contactor.
- PR 240/24, 18 amp power relay contactor.
- PR 277/24, 18 amp power relay contactor.
- ATR – Transformer relays and all PR-power relays require a control section and a 12" (305 mm) long extended enclosure for installation.

Watts/Foot

Models	Watts Per Foot (Single Element Heaters)	Watts Per Foot (Double Element Heaters)
DBT & RDBT	93, 125, 141, 188, 250 & 282	282
DBF & CB	93, 125, 141, 188 & 250	None
DBCF & ASHDB	93, 125, 141, 188, 250, 282, 333 & 375	282, 376, 438 & 500
DBCT	93, 125, 141, 188, 250, 282, 333 & 375	282, 376, 438, 500, 564, 625, 666 & 750

Mechanical Specifications

Model EWFB

Control Sections:

- 6" (152 mm) long control section for factory mounting of 1 or 2 controls. Right or left side mounting are available with right side being standard. Requires one foot (0.3048 M) of extended enclosure for installation. Control sections are field wired to the heater.
- 12" (305 mm) long control section for factory mounting of 1, 2 or 3 controls. Right or left side mounting are available with right side being standard. Requires one foot (0.3048 M) of extended enclosure for installation. Control sections are field wired to the heater.

Accessories: Accessories are approved as 40 ampere wireways and are of the same material and compatible design as the heater section.

- Inside corners 90 - 180 degrees.
- Outside corners 180 - 270 degrees.
- End caps left or right hand.
- 2" (51 mm) and 6" (152 mm) wall trims.
- 1 1/2" (38 mm) splice plates.
- 1/4" (6.4 mm) wire mesh factory installed under outlet grille on enclosure and blank enclosure sections and extended enclosure sections.

- Pedestals – Pedestal brackets are available for floor mounting in lobbies and in front of windows for all models except ASHDB 10" (254 mm), 12" (305 mm), 14" (356 mm), 18" (457 mm) and 20" (508 mm) high heaters. Factory installed to the bottom of the unit for field furnished power wiring to be run through the center of the pedestal into the bottom of the units junction box for connection to the heater.

The knockouts that are provided in the side and rear of each heaters junction box and the back panel mounting holes for wall mounting of units are not furnished when pedestals are ordered.

2' to 6' (0.6 to 1.83 M) heaters require two pedestals, 6' to 8' (1.83 to 2.44 M) heaters require three pedestals, 9' (2.74 M) and 10' (3.05 M) heaters require four pedestals.

- Finished Back Panels – Finished back panels either painted or anodized in the same color as the heater are available for pedestal floor mounted heaters to be installed in front of windows and in lobbies.
- Blank enclosure sections manufactured of solid metal grilles and are independent pieces of enclosure not joined to the heater and are fully enclosed to allow branch circuit wiring. Available in 1 foot (0.3048 M) through 10 foot (3.048 M) lengths in 1 foot (0.3048 M) increments. Can be modified for use with hydronic heating elements for models DBT, DBF, DBCT, DBCF and ASHDB only.

- Color Finish Options
 - Clear Anodized
 - Bronze Anodized
 - Black Anodized
 - Beige Baked Enamel* 2-7-2894
 - White Baked Enamel* 2-1-5098
 - Brown Baked Enamel* 2-7-3894
 - Black Baked Enamel* 2-6-5054

*Colors per Electric Wall Fin Color Selection Chart FIN-S-3.

- Anodized colors available for all models except Model ASHDB.

Hydronic Heating Units

Blank enclosure sections for use with hydronic heating elements are modified to have the air outlet grille and bottom air inlet or bottom front air inlet grille in the same configuration as listed above for each model electric heater.

Maximum Element Fin Size per Model

Model	Maximum Fin Size	
DBT &	2 3/4" x 4"	and 3 1/4" x 3 1/4"
DBCT	70 mm x 102 mm	and 83 mm x 83 mm
DBF &	2 3/4" x 4"	and 2 3/4" x 3"
DBCF	70 mm x 102 mm	and 70 mm x 76 mm
ASHDB	4 1/4" x 4 1/4"	108 mm x 108 mm

Note:
3 1/4" (83 mm) x 5 1/4" (133 mm) fin size and
2 3/4" (70 mm) x 5" (127 mm) fin size cannot be used with these size enclosures.



The Trane Company
An American Standard Company
www.trane.com

For more information contact
your local sales office or
e-mail us at comfort@trane.com

Literature Order Number	FIN-PRC003-EN
File Number	PL-TD-FIN-000-PRC003-EN-1001
Supersedes	FIN-DS-5 0798
Stocking Location	La Crosse

Since The Trane Company has a policy of continuous product and product data improvement, it reserves the right to change design and specifications without notice.

Free Manuals Download Website

<http://myh66.com>

<http://usermanuals.us>

<http://www.somanuals.com>

<http://www.4manuals.cc>

<http://www.manual-lib.com>

<http://www.404manual.com>

<http://www.luxmanual.com>

<http://aubethermostatmanual.com>

Golf course search by state

<http://golfingnear.com>

Email search by domain

<http://emailbydomain.com>

Auto manuals search

<http://auto.somanuals.com>

TV manuals search

<http://tv.somanuals.com>