



# Scroll Liquid Chillers

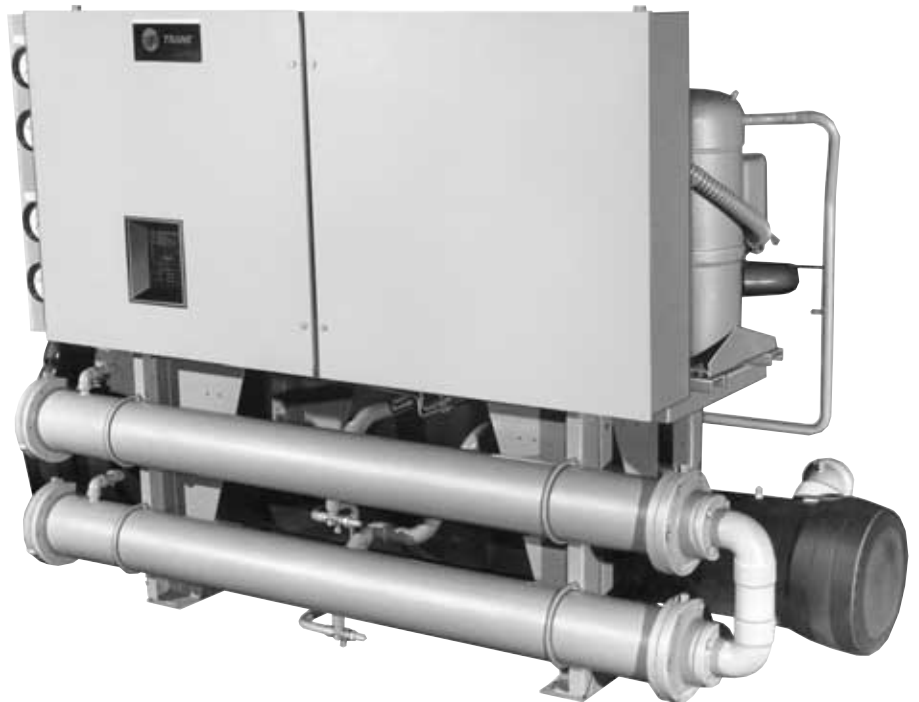
---

**20 to 60 Tons (60 Hz)**

**17 to 50 Tons (50 Hz)**

**Water-Cooled and Condenserless**

*Built For the Industrial and Commercial Markets*



---

January 2002

**CG-PRC011-EN**



# Features and Benefits

## More Than Just Another "Improved" Chiller

- Advanced Design
- Better Reliability
- Superior Efficiency
- Smarter Microprocessor Control
- Better Availability
- Easier To Install and Operate

## The Trane 20-60 Ton Scroll Liquid Chiller

### Design

The Trane scroll compressor is the most advanced compressor in the industry.

### Reliability

64 percent fewer compressor parts, compared to reciprocating compressors, mean long and reliable life.

### Efficiency

CGWE scroll chillers meet and exceed ASHRAE Standard 90.1 full and part load efficiencies. Part load efficiencies are simply unmatched by reciprocating chillers.

### Control

Advanced and complete safety and control algorithms available.

### Availability

Fast ship cycles on both stock and built-to-order specials.

### Installation

Small unit size, factory wiring, easy lifting provisions, and start-up control logic mean quick and easy setup. Chillers fit through standard single-width door.

### Operation

Smart safety features and over 40 diagnostic displays mean easy and virtually trouble-free operation.

Power Supply Monitor Protects Compressors From Phase Loss, Phase Reversal, Phase Imbalance, Incorrect Phase Sequence and Under and Over Voltage

Control Panel

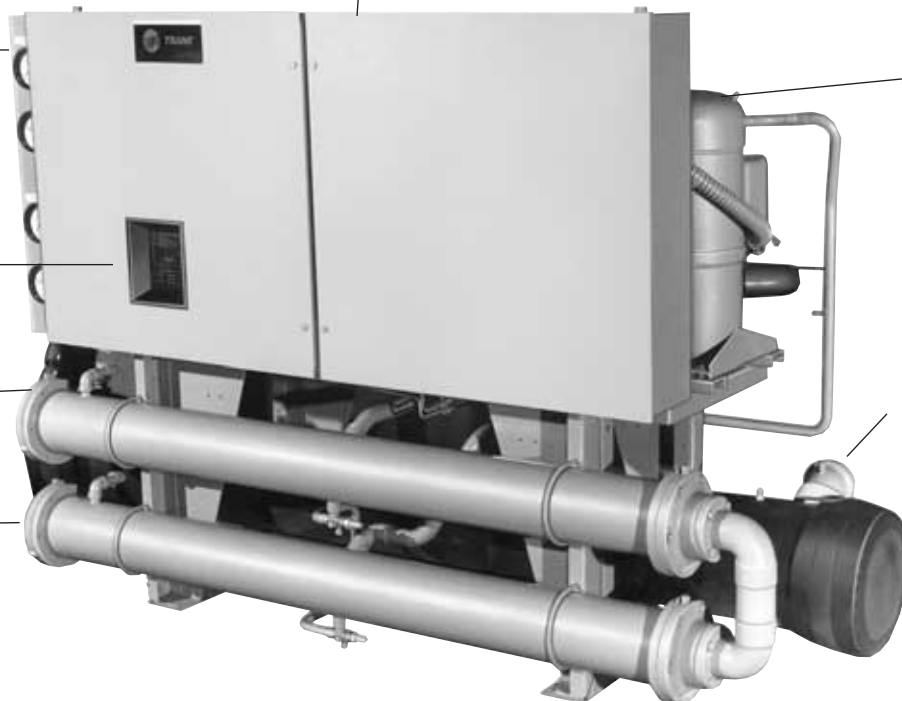
Microprocessor Operator Interface

Condenser Leaving Water Piping

Condenser Entering Water Piping

Rugged Trane Scroll Compressor

Evaporator Leaving Water Piping



# Contents

---

<b>Features and Benefits</b>	<b>2</b>
<b>Model Number Description</b>	<b>9</b>
<b>General Data</b>	<b>10</b>
<b>Application Considerations</b>	<b>11</b>
<b>Selection Procedure</b>	<b>12</b>
<b>Performance Adjustment Factors</b>	<b>13</b>
<b>Performance Data</b>	<b>15</b>
<b>Electrical Data</b>	<b>24</b>
<b>Jobsite Connection</b>	<b>26</b>
<b>Controls</b>	<b>28</b>
<b>Dimensional Data</b>	<b>29</b>
<b>Weights</b>	<b>34</b>
<b>Options</b>	<b>35</b>
<b>Typical Wiring Diagrams</b>	<b>36</b>
<b>Features Summary</b>	<b>38</b>
<b>Mechanical Specifications</b>	<b>39</b>



# Features and Benefits

## Standard Features

### Microprocessor Control

Microprocessor control means the scroll chiller maintains chilled water temperature more accurately, resulting in less temperature drift in the building. The microprocessor control also incorporates optimal chiller start-up logic (low and high ambient), load limiting, compressor anti-recycle timing, auto lead/lag function, compressor protection, and many other safety features. The "smart" safety features provide complete fault protection without nuisance tripping.

**BENEFIT:** consistent, reliable operation, longer life.

### Leaving Chilled Water Temperature Control

The microprocessor actually monitors temperature and the rate of change over time, effectively controlling compressor loading for efficient chiller operation.

**BENEFIT:** accurate and efficient building comfort, less energy wasted.

### Diagnostics and Display

The microprocessor's operator interface is a menu-driven digital display. The display provides temperatures, pressures, setpoints and diagnostics readouts. Flashing display notifies operator of fault condition and diagnostics are saved until manually reset.

**BENEFIT:** easy troubleshooting and control

### Compressor Protection

All compressors are individually protected against starting and running overload, under and over voltages, phase loss, phase reversal, high winding temperature and rapid recycling.

**BENEFIT:** long unit life and added reliability.

### External Control

Several external contacts are provided for custom control requirements including time of day scheduling and kW demand limiting.

**BENEFIT:** more standard control and more flexible owner upgrades.

### Other Standard Features

- Control power transformer
- Auto lead/lag (on or off)
- Solid-state motor protection
- Insulation (Armaflex II or equal)
- Evaporator and condenser water pump interlocks
- Filter-dryer
- Built-in loss of chilled water flow sensors
- Chillers fit through standard single width door.

### Options

- Trane Integrated Comfort™ systems communication
- Generic building automation systems (BAS) interface
- Chilled water reset (ambient, zone, return)
- Ice making
- Hot gas bypass
- Remote display/control panel
- Remote running indication and alarm contact
- Unit-mounted disconnect
- Gauges
- Sound Attenuation
- Neoprene Isolators
- Compressor cycle counter/hour meter
- Water regulating valves
- Condenser water temperature sensors



The standard ARI rating condition (54/44°F and 85°F/3.0 gpm per ton) and IPLV are ARI certified. All other ratings, including the following, are outside the scope of the certification program and are excluded:

- Glycol.
- 50 Hz.
- Condenserless models CCAD.



Water Chiller Systems Business Unit

# Features and Benefits

**ASHRAE Standard 90.1** All Trane chillers meet and exceed the new efficiency levels mandated by ASHRAE Standard 90.1. This new standard requires higher efficiencies than past technologies can deliver. In fact, energy efficiency is so paramount the US Federal Government has adopted standard 90.1. Federal Executive Order mandates energy consuming devices procured must be in the top 25% of their class. In the case of chillers, ASHRAE 90.1 is the product standard for measurement.

**Risk.** Not only has ASHRAE 90.1 been adopted by the US Federal Government, it's expected to be adopted domestically, if not globally, in the future. Make sure that your chillers as well as your entire HVAC system complies, or you may be caught retrofiting your project with new equipment and paying extra design dollars if the code changes during construction.

Trane's CGWE was designed with the end user's requirements in mind. Efficiency and reliability were primary design concerns with this latest generation machine.

## Leading in Efficiency and Reliability with State-Of-The-Art Scroll Compressor Technology

### Efficiency

The energy efficiency of the scroll chiller results in energy costs lower than any other comparable chiller. Full load efficiencies are improved beyond reciprocating chillers, but part load efficiencies are simply unmatched by any other manufacturer.

Superior efficiencies are obtained by combining many of the traditional scroll chiller energy efficient features with the Trane scroll compressor technology. **HERE'S HOW:**

- Scroll compressor's positive displacement design
- Dual refrigerant circuits (40-60 ton units)
- Multiple compressors
- Optimum system design
- Reduced friction
- No valves
- Advanced heat transfer surfaces

### Reliability

The Trane scroll chiller with many new improvements, now brings an exciting new compressor to the commercial market — the Trane scroll compressor. Trane has designed the scroll compressor to be a leader in reliability. **HERE'S HOW:**

- Simple design with 64 percent fewer parts than equal capacity reciprocating compressor.
- Scroll compliance allows liquid and dirt to pass through without damaging compressor (liquid slugging resistant).
- Advanced microelectronics protect both compressor and motor from typical electrical fault conditions.
- Scroll compressors have less than a third the torque variations of a reciprocating compressor.
- Years of laboratory testing have optimized compressor and chiller systems reliability.
- Water-cooled scroll chillers are factory tested.

### Operating Torque

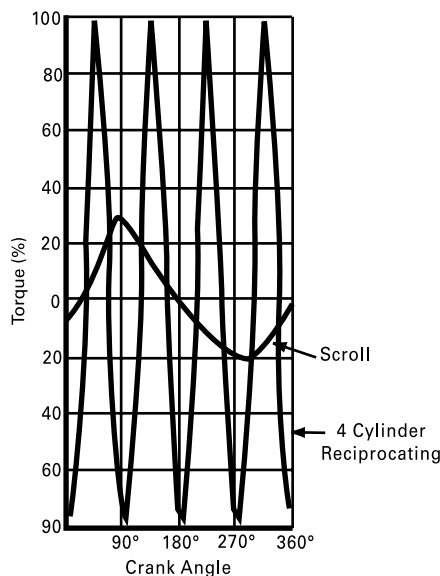
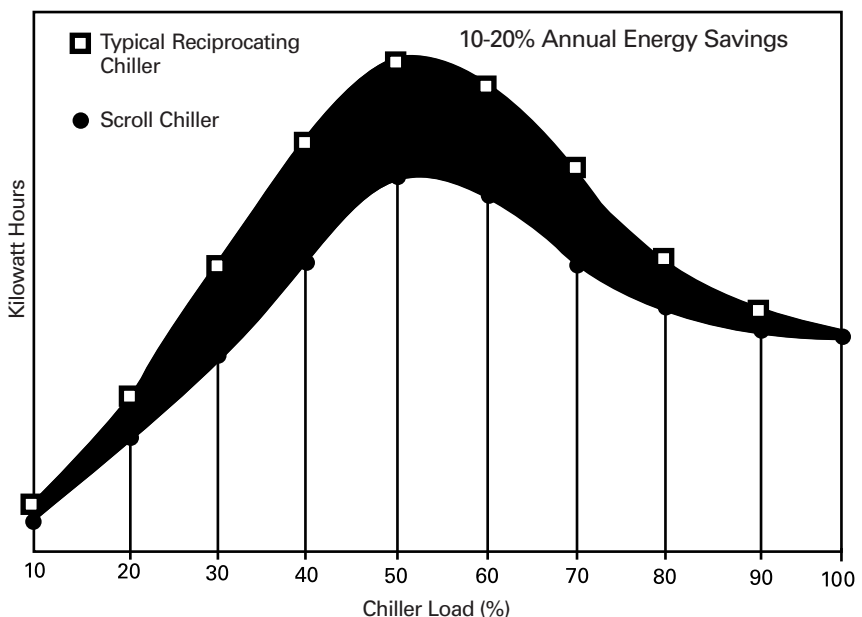


Chart illustrates low torque variation of the Trane scroll compressor vs reciprocating compressor.

### Scroll Chiller Energy Usage Savings



Graph illustrates Trane scroll chiller's superior annual energy costs vs typical reciprocating chillers.

# Features and Benefits

## Trane Scroll Compressor — Maximum Efficiency with Enhanced Reliability

### General

The scroll compressor has two scrolls. The top scroll is fixed and the bottom scroll orbits. Each scroll has walls in a spiral shape that intermesh.

### Inlet-First Orbit

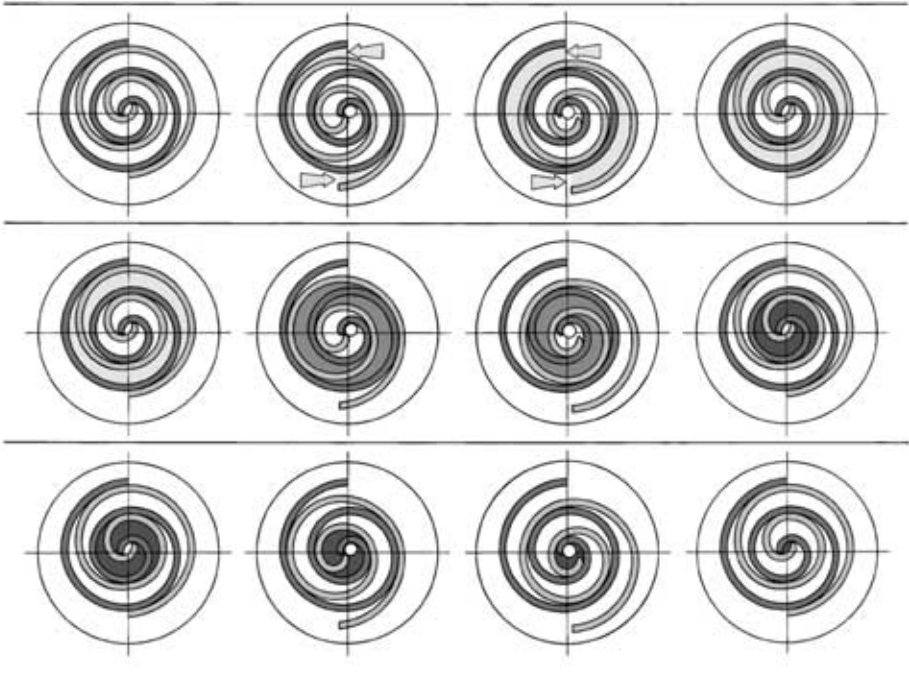
As the bottom scroll orbits, two refrigerant gas pockets are formed and enclosed.

### Compression-Second Orbit

The refrigerant gas is compressed as the volume is reduced closer to the center of the scroll.

### Discharge-Third Orbit

The gas is compressed further and discharged through a small port in the center of the fixed scroll.

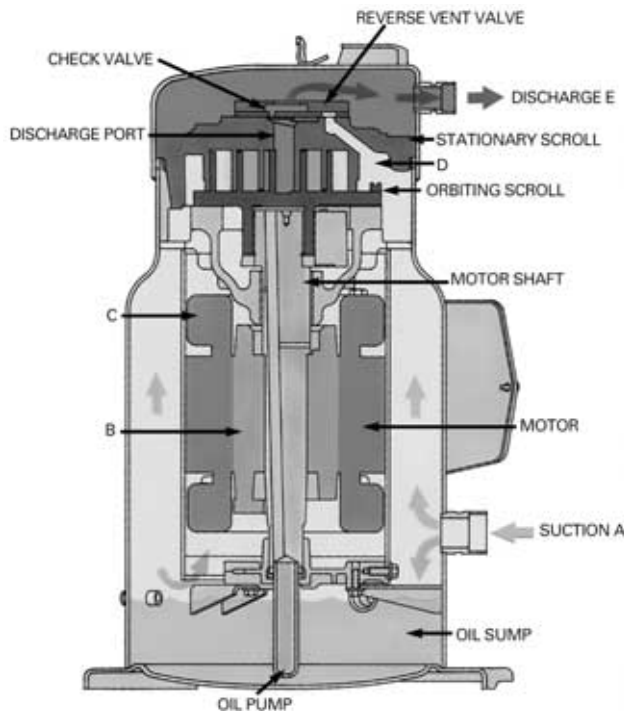


### Scroll Principal Components

This is a cutaway view of a hermetic scroll compressor, showing the relative positions of the principal components. Shown is a Trane 10-ton, 3600 rpm, 60 Hz [3000 rpm, 50 Hz] scroll compressor as an example.

The principle of operation of this example compressor is as follows: The suction gas is drawn into the compressor at A. The gas then passes through the gap between the rotor and stator, B, cooling the motor, before it enters the compressor housing, C. Here, the velocity of the gas is reduced, causing a separation of the entrained oil from the gas stream. The gas then enters the intake chamber, D, that encircles the scrolls.

Finally, the suction gas is drawn into the scroll assembly where it is compressed and discharged into the dome of the compressor. The dome of this example compressor acts as a hot gas muffler which dampens the pulsations before the gas enters the discharge line, E.



# Features and Benefits

---

## Trane Value Means Fast Availability, Easy Installation and Quality Service

### **Packed Stock For Fast Delivery**

When your project is a fast-track job, Trane can help. A wide range of chillers are stocked and can be shipped soon after receipt of your order.

### **Build To Order**

Need a special chiller fast? Think Trane scroll chillers. New manufacturing technology and inventory control means the fastest delivery schedule in the industry. Wide array of standard options provides the right chiller for the job fast.

### **Installation**

- Only one power connection hook-up — for fast and inexpensive installation.
- Integrated Comfort™ system means only single pair connections are required for control interfaces and therefore, lower total installation costs.
- Factory refrigerant and oil charged units help speed installation.
- All units easily fit through a standard single width door.
- Built-in chilled water flow sensors mean no field-installed flow switches are required.
- Microprocessor displays both entering and leaving chilled water temperatures. No chilled water thermometers are required.

### **Easy Serviceability**

Trane 20 through 60 ton scroll chillers are designed with service personnel in mind. All major components are replaceable without complete unit disassembly. Plus, the microprocessor control panel provides diagnostic capability to aid service personnel in analyzing problems. Therefore, if a problem does occur, the chiller can be up and running in a shorter period of time.

### **Quick and Complete Submittals**

The Trane commitment to value-added products doesn't stop at just the products, we are committed to total customer satisfaction. Part of this commitment is to provide quick, complete, readable and accurate drawings.

### **Single-Source Responsibility**

A wide range of products designed for complete compatibility are available with the scroll chillers. Your entire building comfort system can be completed using components from Trane.

### **The Added Value of Applications Expertise**

With the scroll chiller you get applications expertise and know-how from a Trane sales engineer. Trane has more than 1500 sales engineers across the country — each one a degreed engineer. Trane sales engineers have creative ideas and solutions to difficult building comfort system design problems. You can take full advantage of their knowledge in designing a quality, dependable comfort system.

There's more. Your Trane sales engineer is backed by the Trane world headquarters staff of applications experts, regarded as the best in the industry. The C.D.S. Network provides Trane sales engineers — and many independent design and consulting firms — direct access to many comfort system application, selection and design programs.

You get a quality chiller, properly selected and applied in a properly designed system. That means a comfort system that works, the first time!

# Features and Benefits

## The Trane Difference — The Integrated Comfort™ System

### No Other Microprocessor Does More So You Can Do Less

The new microprocessor control system enhances the Trane scroll chiller by providing advanced technology to control chiller operation and associated sensors, actuators, relays and switches.

- Operator interface is improved and easy to use. Panel displays all operating and safety codes with complete diagnostic information. Over 40 diagnostics are included.
- Smart safety features shut down cooling only if absolutely necessary, preventing nuisance safety trip outs.
- Microprocessor easily interfaces with Trane Tracer™ building management computer for Integrated Comfort system benefits; all with a single twisted pair wire!

### Trane Integrated Comfort System The Future Is Now!

#### Simple

- Factory packaging for smooth start-up.
- Easy to install with only a single twisted wire pair to the central Tracer building management system.
- Constant, comprehensive monitoring tracks equipment operation and takes control to keep tenants comfortable.
- Optional override buttons on each floor allow tenants to have control after hours. After-hours use is automatically logged to allow tenant billing.
- Review building performance at a glance with automatically generated reports and logs.
- Enhanced service and building management capability through remote diagnostics and control.
- Trane Building Management Network allows control from across town or across the country.

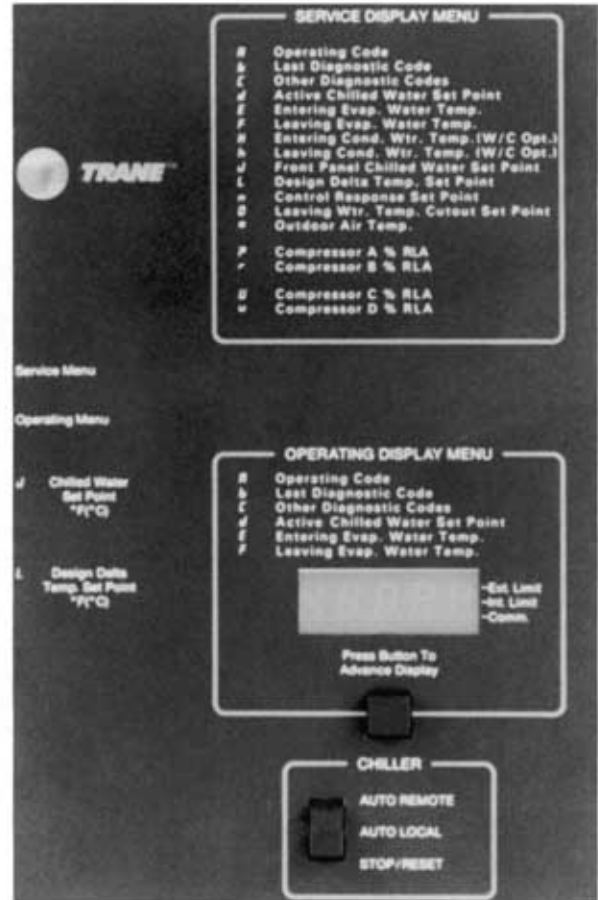
#### A Dependable System From A Single, Reliable Source

- System design, equipment supply and service support all available from Trane.
- Factory testing of all Trane equipment ensures the system works.

### Twisted Pair Communications



**Connects To:  
Trane Integrated  
Comfort Systems  
(No System Control Panel  
(SCP) is necessary)**



### At A Lower Cost

- Factory packaged controls and sensors reduce jobsite labor costs while assuring proper installation.
- Single twisted pair wire communication technology dramatically simplifies installation and reduces jobsite installation costs.
- Because the unit has been factory tested, there are no system problems; allowing smoother start-up, reducing follow-up costs.
- Building block approach allows you to change your system without redundancy and wasted cost.

### No Bad Jobs

There is another benefit from single-source responsibility and the Trane Integrated Comfort systems. With Trane ICS, you get a single-source supplier of the system — from the chillers to the air handlers to the controls. Trane is the only HVAC manufacturer which can provide the entire system.

For more information on how Trane scroll chillers and an Integrated Comfort system can benefit your next HVAC project, contact your nearest Trane sales office.



# Model Number Description

## Model Number Description

**CGW** **E** **020** **4** **C** **XX** **H** **A** **T** **1** **0** **0** **0** **0** **0** **L** **A**  
 1,2,3 4 5,6,7 8 9 10,11 12 13 14 15 16 17 18 19 20 21 22+

### Digits 01, 02, 03, – Chiller Series

CGW = Water-Cooled Scroll Chiller  
 CCA = Scroll Compressor Chiller

### Digits 04, – Development Sequence

### Digits 05, 06, 07 – Nominal Capacity

020 = 20 Tons (Simplex Circuit, 2 Compressors)  
 025 = 25 Tons (Simplex Circuit, 2 Compressors)  
 030 = 30 Tons (Simplex Circuit, 2 Compressors)  
 040 = 40 Tons (Duplex Circuit, 4 Compressors)  
 050 = 50 Tons (Duplex Circuit, 4 Compressors)  
 060 = 60 Tons (Duplex Circuit, 4 Compressors)

### Digit 08 – Unit Voltage

D = 380/60/3  
 G = 200-230/60/3  
 N = 400/50/3  
 S = Special Customer Option  
 4 = 460/60/3  
 5 = 575/60/3

### Digit 09 – Cooling Type

C = Standard Cooling  
 S = Special Customer Option

### Digit 10, 11 – Design Sequence

XX = Factory Assigned

### Digit 12 – Condenser Configuration

H = High Efficiency Condenser  
 0 = No Unit Condenser (CCA, CUA Units)

### Digit 13 – Control Interface

A = Standard Microprocessor Interface  
 B = Multi-Wire Interface (GBAS)  
 C = Chilled Water Reset Return Water, No Comm.  
 D = Chilled Water Reset – Zone Air, No Comm.  
 E = Ice-Making Control  
 F = Remote Display  
 G = Chilled Water Reset – Outside Air  
 S = Special Customer Options  
 T = Bi-Directional Interface (Tracer)

### Digit 14 – Panel Connections

D = Disconnect Switch  
 S = Special Customer Option  
 T = Terminal Block

### Digit 15 – Evaporator Leaving Temperature

1 = Standard 40-60 F  
 2 = Low Temperature 25-39 F  
 3 = Low Temperature 10-25 F  
 4 = Icemaking 20-60 F  
 S = Special Customer Option

### Digit 16 – Remote Alarm Contacts

0 = No Remote Alarm Contacts  
 R = Remote Alarm Contacts

### Digit 17 – Condenser Entering Temperature

0 = Remote Condenser  
 1 = Standard Temperature 60-90 F  
 4 = High Temperature 90-130 F  
 S = Special Customer Option

### Digit 18 – Evap Tube Type

F = Standard Finned Tubes  
 S = Special Customer Option

### Digit 19 – Cond Tube Type

0 = Remote Cond  
 F = Standard Finned Tubes  
 S = Special Customer Option

### Digit 20 – Hot Gas Bypass

0 = Without Hot Gas Bypass  
 B = With Hot Gas Bypass

### Digit 21 – Water Box Orientation

L = Left Hand  
 R = Right Hand  
 S = Special Customer Option

### Digit 22+ – Add-on Options

A = Unit Sound Attenuator  
 C = CSA Listing  
 G = Unit Gauges  
 H = Hour Meter and Cycle Counter  
 L = Low Ambient Lock-Out Thermostat  
 P = Phase Reversal Protection  
 R = Remote Display  
 T = Tracer Monitoring Package  
 U = UL Listing

# General Data

**Table GD-1 — General Data — CGWE Water-Cooled Chiller**

Size		20	25	30	40	50	60
<b>Compressor</b>							
Quantity (1)		2	2	2	2/2	2/2	2/2
Nominal Size (tons) (2)		10/10	10/15	15/15	10-10/10-10	10-15/10-15	15-15/15-15
Steps of Unloading (%)		100,50	100,60	100,50	100,75,50,25	100,80,60,30	100,75,50,25
<b>Evaporator</b>							
Water Storage	(Gallons)	12	11	16	13	21	40
	(Liters)	45	42	61	49	80	151
Min. Flow	(GPM)	24	30	36	48	60	84
	(L/Sec)	1.5	1.9	2.3	3.0	3.8	4.7
Max. Flow	(GPM)	72	90	108	144	180	252
	(L/Sec)	4.5	5.7	6.8	9.1	11.4	17.3
<b>Condenser</b>							
Water Storage	(Gallons)	8.9	8.0	11.7	19.9	18.2	23.5
	(Liters)	33.7	30.3	44.3	75.3	68.9	88.9
Min. Flow	(GPM)	30	36	50	60	72	90
	(L/Sec)	1.9	2.3	3.2	3.8	4.5	5.7
Max. Flow	(GPM)	90	108	146	180	216	325
	(L/Sec)	5.7	6.8	9.2	11.4	13.6	20.5
<b>General Unit</b>							
Refrigerant		R-22	R-22	R-22	R-22	R-22	R-22
No. of Independent Refrigerant Circuits		1	1	1	2	2	2
Refrigerant Charge	(lb)	50	50	90	50/50	50/50	75/75
	(kg)	22.7	22.7	40.8	22.7/22.7	22.7/22.7	34/34
Oil Charge	(Pints)	16	22	28	16/16	22/22	28/28
	(L)	7.6	10.4	13.2	7.6/7.6	10.4/10.4	13.3/13.3

**Notes**

1. Data containing information on two circuits shown as follows: CKT 1/CKT 2
2. Nominal compressor sizes based on 69 Hz.

**Table GD-2 — General Data — CCAD Compressor-Chiller**

Size		20	25	30	40	50	60
<b>Compressor</b>							
Quantity (1)		2	2	2	2/2	2/2	2/2
Nominal Size (tons) (2)		10/10	10/15	15/15	10-10/10-10	10-15/10-15	15-15/15-15
Steps of Unloading (%)		100,50	100,60	100,50	100,75,50,25	100,80,60,30	100,75,50,25
<b>Evaporator</b>							
Water Storage	(Gallons)	12	11	16	13	21	19
	(Liters)	45	42	61	49	80	72
Min. Flow	(GPM)	24	30	36	48	60	84
	(L/Sec)	1.5	1.9	2.3	3.0	3.8	4.7
Max. Flow	(GPM)	72	90	108	144	180	252
	(L/Sec)	4.5	5.7	6.8	9.1	11.4	17.3
<b>General Unit</b>							
Refrigerant		R-22	R-22	R-22	R-22	R-22	R-22
No. of Independent Refrigerant Circuits		1	1	1	2	2	2
Refrigerant Charge	(lb)	6	8	12	6/6	8/8	12/12
	(kg)	2.7	3.6	5.4	2.7/2.7	3.6/3.6	5.5/5.5
Oil Charge	(Pints)	16	22	28	16/16	22/22	28/28
	(L)	7.6	10.4	13.2	7.6/7.6	10.4/10.4	13.3/13.3

**Notes:**

1. Data containing information on two circuits shown as follows: CKT 1/CKT 2
2. Nominal compressor sizes based on 69 Hz.

# Application Considerations

---

## Unit Location

Units should be installed indoors where exposure to rain or water splash is minimal. A level foundation or flooring must be provided which will support at least 150 percent of the operating weight of the unit. The chiller foundation must be rigid to reduce vibration transmission to a minimum. Use of vibration isolators is recommended for applications with sensitive vibration and noise criteria.

Allow service clearance for compressor removal as well as evaporator and condenser tube removal.

## Condenser Water Limitations

Water-cooled scroll chillers start and operate satisfactorily over a range of load conditions with uncontrolled entering water temperature.

Reducing the condenser water temperature is an effective method of lowering the power input required. However, by reducing the condenser water temperature beyond certain limits, the effect causes a reduction in the pressure drop across the thermal expansion valve to a point when system instability may occur.

In general, continuous machine operation with entering condenser water temperature below 60°F [15.5°C] is not recommended. When the condenser water temperature is expected to drop below 60°F [15.5°C], it is recommended that some form of condenser water temperature control be used to ensure optimal machine performance.

## Water Treatment

Use of untreated or improperly treated water in chillers may result in scaling, erosion, corrosion, algae or slime. It is recommended that the services of a qualified water treatment specialist be engaged to determine what treatment, if any, is advisable. Trane assumes no responsibility for the results of untreated, or improperly treated water.

## Water Pumps

Avoid specifying or using 3600 rpm, 60 Hz [3000 rpm, 50 Hz] condenser water and chilled water pumps. Such pumps may operate with objectional noise and vibration. In addition, a low frequency beat may occur due to the slight difference in operating rpm between water pumps and scroll compressor motors. Where noise and vibration-free operation is important, Trane encourages the use of 1750 rpm, 60 Hz [1450 rpm, 50 Hz] pumps.

## Remote Condenser

Remote condensers should be located as close as possible to the chiller to ensure minimum pressure drops of discharge refrigerant. If non-Trane condensers are provided, a subcooling circuit must be provided in order to achieve cataloged performances (16°F [-8.9°C] subcooling).



# Selection Procedures

The chiller capacity tables on the following pages cover the most frequently encountered leaving water temperatures. For temperature drops other than 10°F [5.6°C], refer to Table SP-1, Performance Adjustment Factors, shown below.

Additional chiller selections and performance information can be obtained through your local Trane sales office.

To select a Trane water-cooled scroll chiller, the following information is required:

1. Design load in tons of refrigeration
2. Design chilled water temperature drop
3. Design leaving chilled water temperature
4. Entering condenser water temperature

Evaporator flow rate (gpm) can be determined by using the following formula:

$$\text{gpm} = \frac{\text{Tons} \times 24}{\text{Chilled Water } \Delta T \text{ (}^\circ\text{F)}}$$

Condenser flow rate (gpm) can be determined by using the following formula:

$$\text{gpm} = \frac{24 \times (\text{tons} + (0.285 \times \text{compressor kW}))}{\text{Condenser Water } \Delta T \text{ (}^\circ\text{F)}}$$

**Table SP-1 – Performance Adjustment Factors**

Fouling Factor	Water Delta T	Capacity	Evap. GPM	kW	Cond. GPM
0.00010	8	0.997	1.231	1.000	0.997
	10	1.000	1.000	1.000	1.000
	12	1.007	0.829	1.001	1.006
	14	1.012	0.714	1.001	1.010
	16	1.017	0.628	1.002	1.014

Note:  
This selection procedure is for water only as the solution.

## Scroll Liquid Chiller — (CGWE) — Selection Example:

Given:  
System Load = 40 tons  
Leaving Chilled Water Temperature (LCWT) = 44°F [6.7°C]  
Entering Condenser Water Temperature (EWT) = 85°F [29.4°C]  
Leaving Condenser Water Temperature (LWT) = 95°F [35°C]  
Chilled Water Temperature Drop = 10°F [5.6°C]

1. From Table PD-2 (Performance Data), a CGWE 40 at the given conditions will produce 39.4 tons with a compressor power input of 30.3 kW and a unit EER of 15.6.
2. To determine the evaporator and condenser water pressure drops, the flow rates (gpm) must be determined. Using the formula above, this unit would require an evaporator flow rate of 95 gpm and a condenser flow rate of 115 gpm. (Compressor kW is found in the same table as the capacity.) The Evaporator Pressure Drop Curve, Figure PD-1, indicates that 95 gpm through a 40 ton evaporator results in a pressure drop of 13.8 feet of water. The Condenser Pressure Drop curve, Chart PD-2, indicates 115 gpm through a 40 ton condenser results in a pressure drop of 14 feet of water.
3. The final unit selection is:
  - Qty (1) CGWE 40
  - Cooling Capacity = 39.4 tons
  - Entering/Leaving Chilled Water Temperatures = 54/44°F [12.2/6.7°C]
  - Chilled water flow rate = 95 gpm
  - Evaporator water pressure drop = 13.8 feet
  - Cooling water flow = 115 gpm
  - Condenser water pressure drop = 14 feet
  - Compressor power input = 30.3 kW
  - Unit EER = 15.6

## Compressor Chiller – (CCAD) – Selection Example:

Select the unit for the following conditions:

A compressor chiller is required to produce 45 tons when matched with an air-cooled condenser. The leaving chilled water temperature is 44°F [6.7°C]. The evaporator temperature differential is 10°F [5.6°C]. The ambient temperature is 95°F [35°C].

1. Select the nominal unit size. The performance data is tabulated by leaving chilled water temperature. For example, the standard unit capacities at 44°F [6.7°C] leaving chilled water temperature are found on page 21. The system that best meets the tonnage requirement is a CCAD 50 matched with a CAUC C50. The unit capacity is 47.1 tons with a kW input of 56.3. The compressor chiller EER is 10.0.
2. Calculate the required chilled water flow rate.
3. 
$$\text{gpm} = \frac{\text{Tons} \times 24}{\text{Chilled Water } \Delta T \text{ (}^\circ\text{F)}}$$

From this example,

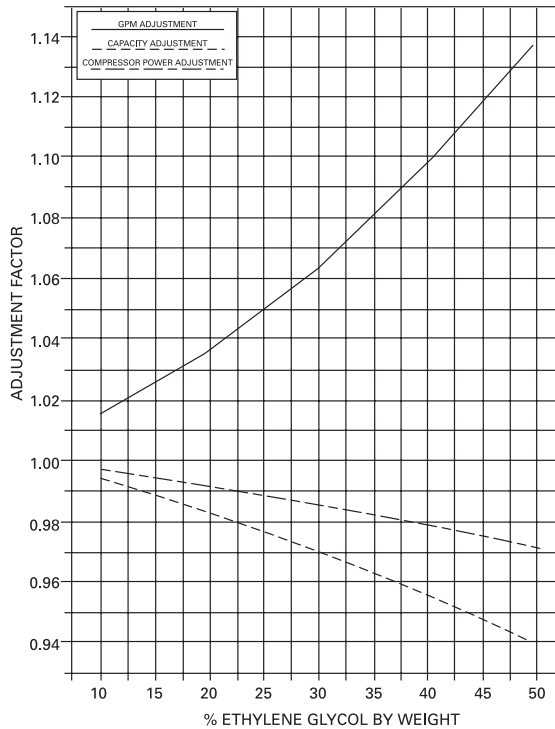
$$\text{gpm} = \frac{47.1 \times 24}{10} = 113$$
4. Determine the evaporator water pressure drop. The evaporator water pressure drop is located on page 22. Entering the evaporator chart at 113 gpm, the pressure drop for a CCAD 50 evaporator is 7.9 feet.
5. Unit Selection
 

The above procedure shows the proper selection for this example is a CCAD 50 with a CAUC C50 condenser operating as follows:

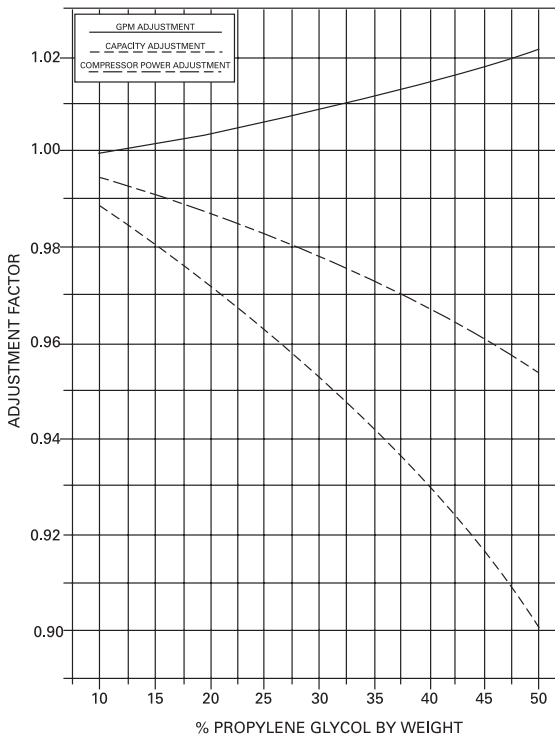
  - Capacity = 47.1
  - Entering/leaving chilled water temperature = 54/44°F [12.2/6.7°C]
  - Chilled water flow rate = 113 gpm
  - Evaporator water pressure drop = 7.9 feet
  - Compressor power input = 56.3
  - Unit EER = 10.0

# Performance Adjustment Factors

**Figure PAF-1 – Ethylene Glycol Performance Adjustment Factors**

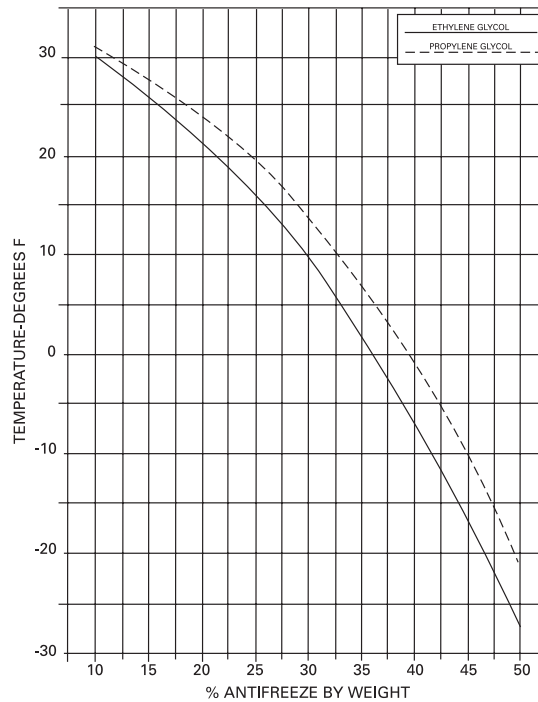


**Figure PAF-2 – Propylene Glycol Performance Adjustment Factors**



# Performance Adjustment Factors

**Figure PAF-3 – Ethylene Glycol and Propylene Glycol Solution Freezing Points**



**Table PAF-1 – Pressure Drop Correction Factor**

Leaving Water Temperature	Percent Of Ethylene Glycol					
	0	10	20	30	40	50
0	NA	NA	NA	NA	1.50	1.60
10	NA	NA	NA	1.38	1.46	1.55
20	NA	NA	1.26	1.34	1.42	1.51
30	NA	1.15	1.22	1.30	1.38	1.47
40	1.00	1.12	1.19	1.26	1.34	1.42
50	1.00	1.09	1.16	1.23	1.31	1.39
60	1.00	1.05	1.09	1.12	1.16	1.21

**Table PAF-2 – Pressure Drop Correction Factor**

Leaving Water Temperature	Percent Of Propylene Glycol					
	0	10	20	30	40	50
0	NA	NA	NA	NA	1.63	1.90
10	NA	NA	NA	1.42	1.55	1.74
20	NA	NA	1.24	1.34	1.46	1.62
30	NA	1.11	1.19	1.28	1.39	1.53
40	1.00	1.07	1.15	1.23	1.33	1.45
50	1.00	1.04	1.11	1.19	1.28	1.39
60	1.00	1.00	1.03	1.08	1.13	1.20

# Performance Data

# Full Load Performance

**Table PD-1 – 60 Hz CGWE Performance Data in English Units**

Evaporator Leaving Water Temperature (F)	Unit Size	Entering Condenser Water Temperature (F)														
		75		80		85		90		95						
		Tons	kW	EER	Tons	kW	EER	Tons	kW	EER	Tons	kW	EER			
40	20	19.2	13.8	16.7	19.0	14.5	15.7	18.6	15.4	14.6	18.1	16.1	13.5	17.7	17.1	12.4
	25	23.8	17.2	16.5	23.2	18.1	15.4	22.7	19.1	14.3	22.1	20.1	13.2	21.6	21.2	12.2
	30	28.3	20.7	16.4	27.6	21.7	15.3	27.0	22.9	14.1	26.3	24.1	13.1	25.6	25.4	12.1
	40	38.0	27.3	16.8	37.2	28.7	15.6	36.5	30.2	14.5	35.5	31.8	13.4	34.6	33.6	12.4
	50	47.0	34.1	16.6	46.0	35.8	15.4	44.9	37.7	14.3	43.8	39.7	13.2	42.7	41.0	12.2
60	57.7	42.1	16.4	56.4	44.2	15.3	55.0	46.5	14.2	53.7	49.0	13.1	52.3	51.7	12.1	
42	20	20.0	13.9	17.3	19.8	14.6	16.3	19.3	15.4	15.1	18.9	16.2	14.0	18.4	17.1	12.9
	25	24.7	17.3	17.1	24.2	18.2	15.9	23.6	19.2	14.8	23.0	20.2	13.7	22.4	21.3	12.6
	30	29.4	20.8	17.0	28.7	21.8	15.8	28.0	23.0	14.7	27.3	24.2	13.6	26.6	25.5	12.5
	40	39.5	27.4	17.3	38.7	28.8	16.1	37.8	30.3	15.0	36.9	32.0	13.9	36.0	33.8	12.8
	50	48.9	34.2	17.2	47.8	36.0	16.0	46.7	37.9	14.8	45.6	39.9	13.7	44.4	42.1	12.7
60	59.9	42.3	17.0	58.5	44.4	15.8	57.2	46.7	14.7	55.7	49.2	13.6	54.3	51.9	12.6	
44	20	20.8	13.9	17.3	20.5	14.7	16.8	19.9	15.4	15.5	19.6	16.3	14.5	19.1	17.2	12.9
	25	25.7	17.4	17.7	25.1	18.3	16.5	24.5	19.1	15.4	23.9	20.3	14.2	23.3	21.4	13.1
	30	30.6	20.8	17.6	29.9	21.9	16.4	29.2	22.9	15.3	28.4	24.3	14.0	27.7	25.6	13.0
	40	41.1	27.5	17.9	40.2	28.9	16.7	39.4	30.3	15.6	38.4	32.1	14.4	37.4	33.9	13.3
	50	50.8	34.4	17.7	49.7	35.1	16.5	48.6	37.8	15.4	47.4	40.1	14.2	46.2	42.3	13.1
60	62.1	42.5	17.6	60.7	44.6	16.3	59.4	46.8	15.2	57.9	49.4	14.1	56.4	52.1	13.0	
46	20	21.5	14.0	18.5	21.3	14.7	17.4	20.9	15.5	16.2	20.4	16.3	15.0	19.9	17.3	13.8
	25	26.6	17.4	18.3	26.1	18.3	17.1	25.5	19.3	15.8	24.9	20.3	14.7	24.2	21.5	13.5
	30	31.7	20.9	18.2	31.0	22.0	16.9	30.3	23.1	15.7	29.5	24.4	14.5	28.7	25.7	13.4
	40	42.6	27.6	18.5	41.7	29.0	17.3	40.8	30.6	16.0	39.9	32.3	14.8	38.9	34.1	13.7
	50	52.8	34.5	18.4	51.6	36.3	17.1	50.4	38.2	15.9	49.2	40.2	14.7	48.0	42.4	13.6
60	64.4	42.6	18.1	63.0	44.8	16.9	61.5	47.1	15.7	60.0	49.6	14.5	58.5	52.3	13.4	
48	20	22.4	14.0	19.1	22.1	14.8	18.0	21.6	15.6	16.7	21.1	16.4	15.5	20.6	17.3	14.3
	25	27.6	17.5	19.0	27.0	18.4	17.6	26.4	19.4	16.4	25.8	20.4	15.2	25.2	21.6	14.0
	30	32.9	21.0	18.8	32.2	22.1	17.5	31.4	23.2	16.2	30.7	24.5	15.0	29.9	25.8	13.9
	40	44.2	27.8	19.1	43.3	29.2	17.8	42.4	30.7	16.6	41.4	32.4	15.3	40.4	34.2	14.2
	50	54.7	34.6	19.0	53.6	35.4	17.7	52.3	38.3	16.4	51.1	40.4	15.2	49.8	42.6	14.0
60	66.7	42.8	18.7	65.2	45.0	17.4	63.7	47.3	16.2	62.2	49.8	15.0	60.7	52.5	13.9	
50	20	23.2	14.1	19.7	22.9	14.8	18.6	22.4	15.6	17.2	21.9	16.5	16.0	21.4	17.4	14.8
	25	28.7	17.6	19.6	28.0	18.5	18.2	27.4	19.4	16.9	26.8	20.5	15.7	26.1	21.6	14.5
	30	34.1	21.1	19.5	33.4	22.1	18.1	32.6	23.3	16.8	31.8	24.6	15.6	31.0	25.0	14.4
	40	45.9	27.9	19.8	44.9	29.3	18.4	43.9	30.8	17.1	42.9	32.5	15.8	41.9	34.3	14.6
	50	56.8	34.8	19.6	55.5	36.5	18.2	54.3	38.5	16.9	53.0	40.5	15.7	51.7	42.8	14.5
60	69.1	43.0	19.3	67.6	45.1	18.0	66.0	47.5	16.7	64.5	50.0	15.5	62.9	52.8	14.3	

**Notes:**

1. Rated in accordance with ARI Standard 550/590-98 with fouling factors of 0.0001 in the evaporator and 0.00025 in the condenser.
2. Consult Trane representative for performance at temperatures outside of the ranges shown.
3. kW input is for compressors only.
4. EER = Energy Efficiency Ratio (Btu/watt-hout). Power inputs include compressors and control power.
5. Ratings are based on an evaporator temperature drop of 10°F.
6. Interpolation between points is permissible. Extrapolation is not permitted.



# Performance Data

# Full Load Performance

**Table PD-2 – 60 Hz CGWE Performance Data in Metric Units**

Evaporator		Entering Condenser Water Temperature (C)								
Leaving Water Temperature (C)	Unit Size	25			30			35		
		kWo	kWi	COP	kWo	kWi	COP	kWo	kWi	COP
6	20	70.4	14.2	5.0	67.7	15.5	4.4	64.7	17.1	3.8
	25	87.1	17.7	4.9	83.5	19.4	4.3	79.8	21.8	3.7
	30	104.0	21.2	4.9	99.6	23.2	4.3	95.1	25.6	3.7
	40	139.5	28.0	5.0	133.9	30.7	4.4	128.1	33.8	3.8
	50	172.4	35.0	4.9	165.3	38.3	4.3	157.9	42.2	3.7
8	60	211.0	43.2	4.9	202.2	47.3	4.3	193.1	52.0	3.7
	20	75.7	14.3	5.3	72.7	15.7	4.6	69.6	17.3	4.0
	25	93.5	17.8	5.3	89.8	19.5	4.6	85.8	21.5	4.0
	30	111.4	21.4	5.2	106.8	23.4	4.6	102.0	25.7	4.0
	40	150.3	28.2	5.3	144.5	30.9	4.7	138.3	34.1	4.1
10	50	185.3	35.2	5.3	177.7	38.6	4.6	169.9	42.5	4.0
	60	226.0	43.5	5.2	216.8	47.6	4.6	207.2	52.4	4.0
	20	80.8	14.4	5.6	77.7	15.8	21.7	74.4	17.4	4.3
	25	99.9	17.9	5.6	95.9	19.6	21.5	91.8	21.6	4.8
	30	119.0	21.5	5.5	114.1	23.6	21.4	109.1	25.9	4.2
10	40	159.9	28.4	5.6	153.8	31.2	21.8	147.3	34.3	4.3
	50	197.9	35.5	5.6	185.9	35.2	23.3	181.7	42.8	4.2
	60	240.7	43.8	5.5	231.0	48.0	21.2	221.0	52.8	4.2

**Notes:**

1. Rated in accordance with ARI Standard 550/590-98 with fouling factors of 0.0000176 in the evaporator and 0.000044 in the condenser.
2. Consult Trane representative for performance at temperatures outside of the ranges shown.
3. kW<sub>i</sub> input is for compressors only.
4. COP = Coefficient of Performance (kW<sub>o</sub>/total kW). Total kW include compressors and control power.
5. Ratings are based on an evaporator temperature drop of 5.6 C.
6. Interpolation between points is permissible. Extrapolation is not permitted.





# Performance Data

# Full Load Performance

**Table PD-3– 50 Hz CGWE Performance Data in English Units**

Evaporator Leaving Water Temperature (F)	Unit Size	Entering Condenser Water Temperature (F)														
		75			80			85			90			95		
		Tons	kW	EER	Tons	kW	EER	Tons	kW	EER	Tons	kW	EER	Tons	kW	EER
42	20	19.2	13.8	16.7	19.0	14.5	15.7	18.6	15.4	14.6	18.1	16.1	13.5	17.7	17.1	12.4
	20	16.8	11.1	18.1	16.4	11.7	16.8	16.0	12.4	15.5	15.6	13.1	14.3	15.3	13.9	13.1
	25	20.7	13.9	17.9	20.3	14.6	16.6	19.8	15.5	15.4	19.4	16.3	14.2	18.9	17.3	13.1
	30	24.6	16.7	17.7	24.1	17.5	16.5	23.6	18.5	15.3	23.0	19.5	14.1	22.5	20.7	13.0
	40	33.2	21.9	18.2	32.5	23.1	16.9	31.8	24.4	15.6	31.0	25.9	14.4	30.2	27.4	13.2
	50	41.0	27.4	17.9	40.1	28.9	16.7	39.2	30.5	15.5	38.3	32.2	14.3	37.4	34.1	13.1
44	20	17.4	11.1	18.8	17.1	11.7	17.4	16.7	12.4	16.1	16.3	13.2	14.9	15.9	13.9	13.7
	25	21.5	13.9	18.6	21.1	14.7	17.3	20.6	15.5	16.0	20.1	16.4	14.8	19.6	17.3	13.6
	30	25.6	16.7	18.4	25.1	17.6	17.1	24.5	18.5	15.9	24.0	19.6	14.7	23.4	20.7	13.5
	40	34.5	22.0	18.9	33.8	23.2	17.5	33.0	24.5	16.2	32.2	25.9	14.9	31.4	27.5	13.7
	50	42.6	27.5	18.6	41.7	29.0	17.3	40.8	30.6	16.0	39.9	32.3	14.8	38.9	34.2	13.6
	60	52.3	33.9	18.5	51.2	35.7	17.2	50.1	37.6	16.0	48.9	39.7	14.8	47.7	42.0	13.7
46	20	18.1	11.2	19.5	17.7	11.8	18.1	17.3	12.4	16.7	16.9	13.2	15.4	16.5	14.0	14.2
	25	22.4	13.9	19.2	21.9	14.7	17.9	21.4	15.5	16.6	20.9	16.4	15.3	20.4	17.4	14.1
	30	26.6	16.7	19.1	26.0	17.6	17.7	25.5	18.6	16.5	24.9	19.6	15.2	24.3	20.8	14.0
	40	35.8	22.0	19.6	35.1	23.2	18.2	34.3	24.5	16.8	33.5	26.0	15.5	32.7	27.5	14.2
	50	44.3	27.6	19.3	43.3	29.0	17.9	42.4	30.6	16.6	41.4	32.4	15.4	40.4	34.3	14.2
	60	54.2	34.0	19.1	53.1	35.8	17.8	51.9	37.7	16.5	50.8	39.8	15.3	49.5	42.1	14.1
48	20	18.8	11.2	20.2	18.4	11.8	18.8	18.0	12.5	17.3	17.6	13.2	16.0	17.2	14.0	14.7
	25	23.2	14.0	19.9	22.7	14.7	18.5	22.2	15.5	17.2	21.7	16.4	15.9	21.2	17.4	14.6
	30	27.6	16.8	19.7	27.0	17.7	18.4	26.5	18.6	17.0	25.9	19.7	15.8	25.2	20.8	14.5
	40	37.2	22.0	20.3	36.4	23.2	18.8	35.6	24.6	17.4	34.8	26.0	16.1	34.0	27.6	14.8
	50	45.9	27.6	20.0	45.0	29.1	18.6	44.0	30.7	17.2	43.0	32.4	15.9	42.0	34.3	14.7
	60	56.1	34.1	19.8	55.0	35.9	18.4	53.9	37.8	17.1	52.6	40.0	15.8	51.4	42.2	14.6
50	20	19.5	11.2	20.9	19.1	11.8	19.4	18.7	12.5	18.0	18.3	13.2	16.6	17.8	14.0	15.3
	25	24.1	14.0	20.6	23.6	14.8	19.2	23.1	15.6	17.8	22.6	16.5	16.4	22.0	17.4	15.1
	30	28.6	16.8	20.4	28.0	17.7	19.0	27.5	18.7	17.6	26.8	19.7	16.3	26.2	20.9	15.1
	40	38.6	22.1	21.0	37.8	23.3	19.5	37.0	24.6	18.0	36.1	26.1	16.6	35.3	27.6	15.3
	50	47.6	27.7	20.7	46.7	29.1	19.2	45.7	30.8	17.8	44.6	32.5	16.5	43.6	34.4	15.2
	60	58.1	34.2	20.4	57.0	36.0	19.0	55.8	37.9	17.7	54.5	40.1	16.3	53.3	42.3	15.1

**Notes:**

1. Rated in accordance with ARI Standard 550/590-98 with fouling factors of 0.00010 in the evaporator and 0.00025 in the condenser.
2. Consult Trane representative for performance at temperatures outside of the ranges shown.
3. kW input is for compressors only.
4. EER = Energy Efficiency Ratio (Btu/watt-hour). Power inputs include compressors and control power.
5. Ratings are based on an evaporator temperature drop of 10°F.
6. Interpolation between points is permissible. Extrapolation is not permitted.



# Performance Data

# Full Load Performance

**Table PD-4 – 50 Hz CGWE Performance Data in Metric Units**

Evaporator		Entering Condenser Water Temperature (C)								
Leaving Water Temperature (C)	Unit Size	25			30			35		
		kWo	kWi	COP	kWo	kWi	COP	kWo	kWi	COP
6	20	70.4	14.2	5.0	67.7	15.5	4.4	64.7	17.1	3.8
	20	59.4	11.4	5.2	57.0	12.6	4.5	54.5	14.0	3.9
	25	73.4	14.2	5.2	70.5	15.7	4.5	67.5	17.3	3.9
	30	87.3	17.0	5.1	83.9	18.7	4.5	80.3	20.7	3.9
	40	117.6	22.4	5.2	112.9	24.8	4.6	108.0	27.5	3.9
	50	145.3	28.0	5.2	139.7	30.9	4.5	133.7	34.2	3.9
8	60	178.4	34.5	5.2	171.7	38.0	4.5	164.0	41.9	3.9
	20	63.7	11.4	5.6	61.2	12.6	4.9	58.5	14.0	4.2
	25	78.6	14.3	5.5	75.6	15.7	4.8	72.3	17.4	4.2
	30	93.5	17.1	5.5	89.9	18.8	4.8	86.1	20.8	4.1
	40	126.0	22.5	5.6	121.0	24.8	4.9	115.8	27.8	4.2
	50	155.6	28.2	5.5	149.5	31.0	4.8	143.2	34.3	4.2
10	60	190.4	34.7	5.5	183.3	38.2	4.8	175.6	42.2	4.2
	20	68.1	11.4	6.0	65.4	12.6	5.2	62.7	14.0	4.5
	25	84.0	14.3	5.9	80.8	15.8	5.1	77.4	17.5	4.4
	30	99.9	17.2	5.8	96.2	18.9	5.1	92.2	20.9	4.4
	40	134.8	22.6	6.0	129.5	24.9	5.2	124.2	27.7	4.5
	50	166.4	28.3	5.9	160.1	31.1	5.1	153.4	34.5	4.4
	60	203.0	34.9	5.8	195.3	38.4	5.1	187.2	42.4	4.4

**Notes:**

1. Rated in accordance with ARI Standard 550/590-98 with fouling factors of 0.0000176 in the evaporator and 0.000044 in the condenser.
2. Consult Trane representative for performance at temperatures outside of the ranges shown.
3. kW<sub>i</sub> input is for compressors only.
4. COP = Coefficient of Performance (kW<sub>o</sub>/total kW). Total kW include compressors and control power.
5. Ratings are based on an evaporator and condenser temperature drop of 5.6°C.
6. Interpolation between points is permissible. Extrapolation is not permitted.

# Performance Data

# Part Load Performance

**Table PD-5 – Part-Load Performance for CGWE 20-60 Ton – 60 Hz in English Units**

Unit Size		100%	75%	50%	25%	IPLV
20	Tons	19.9	14.9	9.9	5.0	20.3
	kW	15.2	9.4	5.3	2.7	
	EER	15.5	18.6	21.9	20.7	
25	Tons	24.5	18.4	12.3	6.1	20.5
	kW	19.0	11.6	6.5	3.4	
	EER	15.4	18.8	22.1	20.9	
30	Tons	29.2	21.9	14.6	7.3	20.3
	kW	22.8	14.1	7.8	4.0	
	EER	15.3	18.5	22.0	20.8	
40	Tons	39.4	29.5	19.7	9.8	20.7
	kW	30.1	18.7	10.3	5.2	
	EER	15.6	18.7	22.4	21.6	
50	Tons	48.6	36.5	24.3	12.2	19.6
	kW	37.6	23.6	14.4	6.7	
	EER	15.4	18.3	20.3	21.7	
60	Tons	59.4	44.5	29.7	14.8	19.8
	kW	46.5	28.3	17.4	7.8	
	EER	15.2	18.7	20.2	22.3	

**Notes:**

1. IPLV values are rated in accordance with ARI Standard 550/590-98.
2. EER and IPLV values include compressor and control kW.
3. kW input is for compressors only.

**Table PD-6 – Part-Load Performance for CGWE 20-60 Ton – 50 Hz in English Units**

Unit Size		100%	75%	50%	25%	IPLV
20	Tons	16.7	12.5	8.3	4.2	21.0
	kW	12.4	7.8	4.4	2.3	
	EER	16.1	19.2	22.6	21.9	
25	Tons	20.6	15.5	10.3	5.2	20.9
	kW	15.5	9.7	5.5	2.9	
	EER	16.0	19.2	22.5	21.5	
30	Tons	24.5	18.4	12.3	6.1	20.7
	kW	18.5	11.7	6.6	3.5	
	EER	15.9	18.9	22.4	20.9	
40	Tons	33.0	24.8	16.5	8.3	21.3
	kW	24.5	15.3	8.6	4.5	
	EER	16.2	19.5	23.0	22.1	
50	Tons	40.8	30.6	20.4	10.2	20.3
	kW	30.6	19.0	11.7	5.6	
	EER	16.0	19.3	20.9	21.9	
60	Tons	50.1	37.6	25.1	12.5	20.4
	kW	37.6	23.3	14.4	6.6	
	EER	16.0	19.4	20.9	22.7	

**Notes:**

1. IPLV values are rated in accordance with ARI Standard 550/590-98.
2. EER and IPLV values include compressor and control kW.
3. kW input is for compressors only.



# Performance Data

# Full Load Performance

**Table PD-7 – 60 Hz CCAD Performance Data in English Units**

Evaporator Leaving Water Temperature (°F)	Unit Size	Condenser Size	Entering Condenser Air Temperature											
			85			95			105			115		
			Tons	kW	EER	Tons	kW	EER	Tons	kW	EER	Tons	kW	EER
42	20	CAUC-C20	19.4	19.5	11.8	18.4	21.6	10.1	17.3	23.9	8.6	16.1	26.6	7.2
	20	CAUC-C25	19.7	18.6	12.6	18.7	20.6	10.8	17.6	23.0	9.1	16.5	25.5	7.7
	25	CAUC-C25	24.1	24.9	11.5	22.8	27.6	9.9	21.5	30.6	8.4	20.0	34.0	7.0
	25	CAUC-C30	24.5	23.4	12.5	23.3	26.0	10.7	22.0	28.9	9.1	20.6	32.1	7.7
	30	CAUC-C30	28.8	29.1	11.8	27.3	32.2	10.1	25.7	35.7	8.6	24.1	39.6	7.3
	30	CAUC-C40	29.2	27.0	12.9	27.8	29.9	11.1	26.3	33.2	9.5	24.7	36.9	8.0
	40	CAUC-C40	38.7	38.8	11.9	36.7	43.0	10.2	34.5	47.8	8.6	32.2	53.2	7.2
	40	CAUC-C50	39.1	37.4	12.5	37.1	41.6	10.6	35.0	46.2	9.0	32.7	51.4	7.6
	50	CAUC-C50	47.6	50.2	11.3	45.1	55.6	9.7	42.5	61.8	8.2	39.7	68.4	6.9
	50	CAUC-C60	48.4	47.0	12.3	46.0	52.2	10.5	43.5	58.2	8.9	40.8	64.6	7.6
	60	CAUC-C60	56.9	58.4	11.6	54.0	64.8	10.0	50.9	71.8	8.5	47.6	79.8	7.1
	60	CAUC-C80	57.5	53.6	12.8	54.7	59.6	11.0	51.8	66.4	9.3	48.6	73.8	7.9
44	20	CAUC-C20	20.0	19.7	12.1	19.0	21.8	10.4	17.8	24.2	8.8	16.6	26.8	7.4
	20	CAUC-C25	20.4	18.8	12.9	19.3	20.8	11.0	18.2	23.2	9.3	17.1	25.7	7.9
	25	CAUC-C25	24.9	25.1	11.8	23.6	27.9	10.1	22.2	30.9	8.6	20.7	34.3	7.2
	25	CAUC-C30	25.3	23.7	12.7	24.1	26.3	10.9	22.7	29.2	9.3	21.3	32.4	7.9
	30	CAUC-C30	29.7	29.4	12.1	28.2	32.6	10.3	26.6	36.1	8.8	24.9	40.0	7.4
	30	CAUC-C40	30.2	27.2	13.2	28.8	30.2	11.4	27.2	33.5	9.7	25.6	37.2	8.2
	40	CAUC-C40	39.9	39.2	12.1	37.8	43.4	10.4	35.6	48.2	8.8	33.3	53.6	7.4
	40	CAUC-C50	40.3	37.8	12.7	38.3	42.0	10.9	36.1	46.6	9.2	33.8	51.8	7.8
	50	CAUC-C50	49.1	50.6	11.6	46.6	56.2	9.9	43.9	62.2	8.4	41.0	69.0	7.1
	50	CAUC-C60	50.0	47.4	12.6	47.5	52.6	10.8	44.9	58.6	9.2	42.2	65.2	7.7
	60	CAUC-C60	58.7	58.5	12.0	55.7	65.4	10.2	52.6	72.6	8.7	49.2	80.6	7.3
	60	CAUC-C80	59.3	54.0	13.1	56.5	60.0	11.3	53.5	66.8	9.6	50.3	74.4	8.1
46	20	CAUC-C20	20.7	19.9	12.4	19.6	22.0	10.6	18.4	24.4	9.0	17.2	27.1	7.6
	20	CAUC-C25	21.0	18.9	13.2	20.0	21.0	11.3	18.8	23.4	9.6	17.6	25.9	8.1
	25	CAUC-C25	25.7	25.4	12.1	24.3	28.2	10.3	22.9	31.2	8.8	21.4	34.6	7.4
	25	CAUC-C30	26.2	23.9	13.1	24.9	26.5	11.2	23.5	29.5	9.5	22.0	32.6	8.1
	30	CAUC-C30	30.7	29.7	12.3	29.1	32.9	10.6	27.5	36.4	9.0	25.7	40.4	7.6
	30	CAUC-C40	31.2	27.4	13.6	29.7	30.4	11.7	28.2	33.8	10.0	26.5	37.5	8.4
	40	CAUC-C40	41.1	38.6	12.7	39.0	43.8	10.6	36.8	48.8	9.0	34.4	54.0	7.6
	40	CAUC-C50	41.6	38.0	13.1	39.5	42.2	11.2	37.3	47.0	9.5	35.0	52.2	8.0
	50	CAUC-C50	50.6	51.2	11.8	48.0	56.6	10.1	45.3	62.8	8.6	42.3	69.8	7.2
	50	CAUC-C60	51.6	47.8	12.9	49.1	53.2	11.0	46.4	59.0	9.4	43.6	65.6	7.9
	60	CAUC-C60	60.5	59.4	12.2	57.5	66.0	10.4	54.3	73.2	8.9	50.9	81.2	7.5
	60	CAUC-C80	61.2	54.4	13.4	58.3	60.6	11.5	55.2	67.4	9.8	52.0	75.0	8.3

**Notes:**

1. Ratings based on sea level altitude and evaporator fouling factor of 0.00010.
2. Consult Trane representative for performance at temperatures outside of the ranges shown.
3. kW input is for compressors only.
4. EER = Energy Efficiency Ratio (Btu/watt-hour). Power inputs include compressors and control power.
5. Ratings are based on an evaporator temperature drop of 10°F.
6. Interpolation between points is permissible. Extrapolation is not permitted.
7. Rated in accordance with ARI Standard 550/590-98.

# Performance Data

# Full Load Performance

**Table PD-8 – 60 Hz CCAD Performance Data in English Units**

Evaporator Leaving Water Temperature (°F)	Unit Size	Condenser Size	Entering Condenser Air Temperature											
			85			95			105			115		
			Tons	kW	EER	Tons	kW	EER	Tons	kW	EER	Tons	kW	EER
48	20	CAUC-C20	21.3	20.1	12.6	20.2	22.2	10.8	19.0	24.6	9.2	17.7	27.3	7.7
	20	CAUC-C25	21.7	19.1	13.5	20.6	21.2	11.6	19.4	23.6	9.8	18.2	26.2	8.3
	25	CAUC-C25	26.5	25.7	12.3	25.1	28.4	10.5	23.7	31.5	9.0	22.1	34.9	7.6
	25	CAUC-C30	27.0	24.1	13.4	25.7	26.7	11.5	24.3	29.6	9.8	22.8	32.9	8.3
	30	CAUC-C30	31.6	30.0	12.6	30.1	33.2	10.8	28.4	36.8	9.2	26.6	40.7	7.8
	30	CAUC-C40	32.2	27.7	13.9	30.7	30.7	11.9	29.1	34.1	10.2	27.4	37.8	8.7
	40	CAUC-C40	42.4	40.0	12.6	40.2	44.4	10.8	37.9	49.2	9.2	35.5	54.6	7.8
	40	CAUC-C50	42.8	38.4	13.3	40.7	42.6	11.4	38.5	47.4	9.7	36.1	52.6	8.2
	50	CAUC-C50	52.2	51.6	12.1	49.5	57.2	10.3	46.7	63.4	8.8	43.7	70.2	7.4
	50	CAUC-C60	53.2	48.2	13.2	50.6	53.6	11.3	47.9	59.6	9.6	45.0	66.2	8.1
	60	CAUC-C60	62.4	60.2	12.4	59.3	66.6	10.6	56.0	74.0	9.1	52.5	82.0	7.7
	60	CAUC-C80	63.1	54.8	13.8	60.2	61.8	11.8	57.0	67.8	10.1	53.7	75.4	8.5
50	20	CAUC-C20	21.9	20.3	12.8	20.8	22.5	11.0	19.6	24.9	9.4	18.3	27.6	7.9
	20	CAUC-C25	22.3	19.3	13.8	21.2	21.4	11.8	20.1	23.8	10.1	18.8	26.4	8.5
	25	CAUC-C25	27.3	25.9	12.6	25.9	28.7	10.8	24.4	31.8	9.2	22.9	35.2	7.8
	25	CAUC-C30	27.9	24.3	13.7	26.5	26.9	11.8	25.1	29.9	10.0	23.5	33.1	8.5
	30	CAUC-C30	32.6	30.3	12.8	31.0	33.6	11.0	29.3	37.2	9.4	27.5	41.1	8.0
	30	CAUC-C40	33.2	27.9	14.2	31.7	30.9	12.2	30.0	34.3	10.4	28.3	38.1	8.9
	40	CAUC-C40	43.6	40.4	12.9	41.4	44.8	11.0	39.1	49.6	9.4	36.6	55.0	8.0
	40	CAUC-C50	44.1	38.8	13.6	42.0	43.0	11.7	39.7	47.8	9.9	37.2	53.0	8.4
	50	CAUC-C50	53.7	52.2	12.3	51.0	57.8	10.5	48.1	64.0	9.0	45.1	71.0	7.6
	50	CAUC-C60	54.8	48.6	13.5	52.2	54.0	11.5	49.4	60.0	9.8	46.4	66.6	8.3
	60	CAUC-C60	64.3	60.8	12.6	61.1	67.4	10.8	57.8	74.6	9.3	54.2	82.8	7.8
	60	CAUC-C80	65.1	55.4	14.0	62.1	61.4	12.1	58.8	68.4	10.3	55.4	76.0	8.7

**Notes:**

1. Ratings based on sea level altitude and evaporator fouling factor of 0.00010.
2. Consult Trane representative for performance at temperatures outside of the ranges shown.
3. kW input is for compressors only.
4. EER = Energy Efficiency Ratio (Btu/watt-hour). Power inputs include compressors and control power.
5. Ratings are based on an evaporator temperature drop of 10°F.
6. Interpolation between points is permissible. Extrapolation is not permitted.
7. Rated in accordance with ARI Standard 550/590-98.



# Performance Data

# Full Load Performance

**Table PD-9 – 60 Hz. CCAD Performance Data in Metric Units**

Evaporator Leaving Water Temperature (°F)	Unit Size	Condenser Size	Entering Condenser Air Temperature (°C)											
			30			35			40			45		
			kWo	kWi	COP	kWo	kWi	COP	kWo	kWi	COP	kWo	kWi	COP
6	20	CAUC-C20	69.4	19.8	3.5	66.2	21.7	3.0	62.5	23.8	2.6	58.7	26.2	2.2
	20	CAUC-C25	70.7	18.9	3.7	67.3	20.7	3.2	63.8	22.9	2.8	60.3	25.1	2.4
	25	CAUC-C25	86.2	25.3	3.4	82.1	27.8	2.9	77.8	30.5	2.5	73.1	33.5	2.2
	25	CAUC-C30	87.8	23.8	3.7	84.0	26.2	3.2	79.7	28.8	2.8	75.2	31.7	2.4
	30	CAUC-C30	103.0	29.6	3.5	98.2	32.4	3.0	93.1	35.6	2.6	87.9	39.1	2.2
	30	CAUC-C40	104.7	27.4	3.8	100.3	30.1	3.3	95.3	33.1	2.9	90.2	36.4	2.5
	40	CAUC-C40	138.4	39.5	3.5	131.9	43.3	3.0	124.8	47.6	2.6	117.5	52.4	2.2
	40	CAUC-C50	140.0	38.1	3.7	133.6	41.9	3.2	126.8	46.0	2.7	119.5	50.7	2.3
	50	CAUC-C50	170.2	51.0	3.3	162.3	56.0	2.9	153.8	61.5	2.5	144.8	67.5	2.1
	50	CAUC-C60	173.5	47.8	3.6	165.7	52.5	3.1	157.6	57.9	2.7	149.0	63.7	2.3
	60	CAUC-C60	203.5	59.2	3.4	194.1	65.2	3.0	184.2	71.6	2.6	173.6	78.7	2.2
	60	CAUC-C80	206.0	54.5	3.8	197.0	59.9	3.3	187.6	66.1	2.8	177.5	72.7	2.4
8	20	CAUC-C20	73.5	20.2	3.6	70.0	22.1	3.1	66.2	24.3	2.7	62.3	26.7	2.3
	20	CAUC-C25	74.8	19.2	3.9	71.5	21.1	3.4	67.7	23.3	2.9	63.9	25.5	2.5
	25	CAUC-C25	91.3	25.8	3.5	86.8	28.3	3.1	82.4	31.0	2.6	77.6	34.1	2.3
	25	CAUC-C30	93.3	24.3	3.8	89.1	26.6	3.3	84.6	29.3	2.9	79.9	32.1	2.5
	30	CAUC-C30	109.1	30.2	3.6	104.0	33.0	3.1	98.9	36.2	2.7	93.2	39.8	2.3
	30	CAUC-C40	111.1	27.8	4.0	106.3	30.5	3.5	101.4	33.6	3.0	96.1	36.9	2.6
	40	CAUC-C40	146.1	39.5	3.7	139.3	44.0	3.1	132.2	48.5	2.7	124.6	53.2	2.3
	40	CAUC-C50	148.0	38.6	3.8	141.3	42.4	3.3	134.3	46.7	2.9	126.9	51.4	2.5
	50	CAUC-C50	179.9	52.0	3.4	171.5	56.9	3.0	162.8	62.5	2.6	153.3	68.7	2.2
	50	CAUC-C60	183.7	48.5	3.8	175.6	53.4	3.3	167.0	58.7	2.8	158.0	64.6	2.4
	60	CAUC-C60	215.1	60.4	3.5	205.4	66.3	3.1	195.1	72.8	2.7	184.3	80.0	2.3
	60	CAUC-C80	217.9	55.3	3.9	208.6	61.0	3.4	198.6	67.0	3.0	188.4	73.8	2.5
10	20	CAUC-C20	77.4	20.6	3.7	73.8	22.6	3.3	70.0	24.7	2.8	65.9	27.1	2.4
	20	CAUC-C25	78.9	19.6	4.0	75.4	21.5	3.5	71.9	23.6	3.0	67.8	25.9	2.6
	25	CAUC-C25	96.4	26.2	3.7	92.0	28.8	3.2	87.2	31.6	2.7	82.4	34.6	2.4
	25	CAUC-C30	98.7	24.6	4.0	94.2	27.0	3.5	89.7	29.7	3.0	84.7	32.5	2.6
	30	CAUC-C30	115.2	30.7	3.7	110.1	33.7	3.3	104.6	36.9	2.8	98.9	40.4	2.4
	30	CAUC-C40	117.5	28.3	4.1	112.7	31.0	3.6	107.3	34.0	3.1	101.8	37.4	2.7
	40	CAUC-C40	154.0	40.9	3.7	147.0	44.9	3.3	139.6	49.2	2.8	131.7	54.1	2.4
	40	CAUC-C50	156.0	39.3	3.9	149.3	43.1	3.4	142.0	47.4	3.0	134.0	52.1	2.6
	50	CAUC-C50	189.7	52.9	3.6	181.1	57.9	3.1	171.8	63.5	2.7	162.3	69.8	2.3
	50	CAUC-C60	193.9	49.3	3.9	185.6	54.1	3.4	176.6	59.6	3.0	167.1	65.4	2.5
	60	CAUC-C60	227.2	61.6	3.7	216.9	67.6	3.2	206.4	74.1	2.8	195.0	81.4	2.4
	60	CAUC-C80	230.4	56.1	4.1	220.8	61.6	3.6	210.2	67.9	3.1	199.4	74.7	2.7

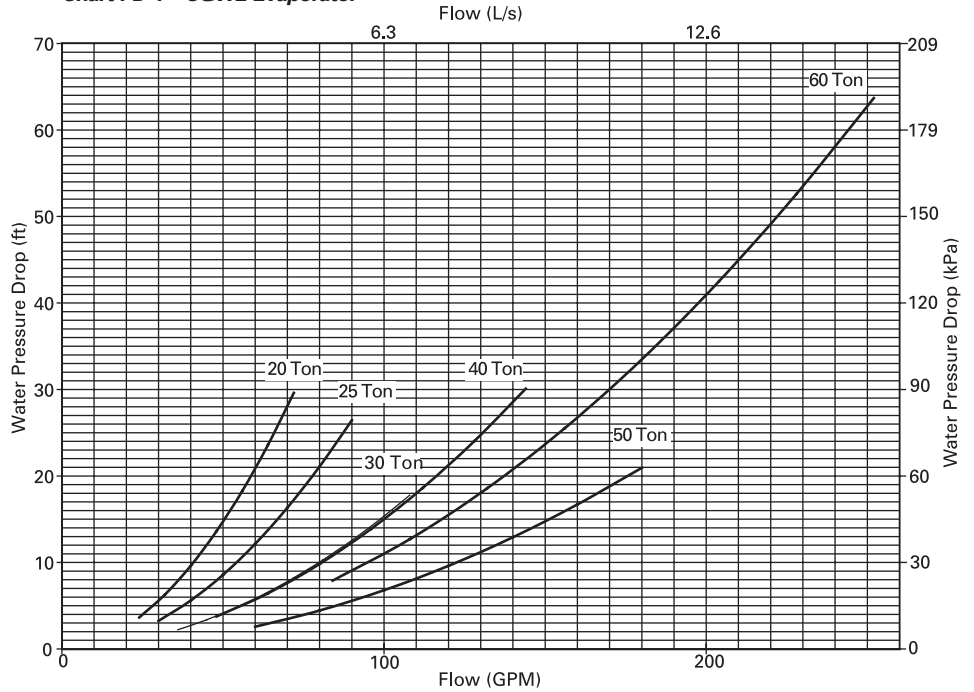
**Notes:**

1. Ratings based on sea level altitude and evaporator fouling factor of 0.0000176.
2. Consult Trane representative for performance at temperatures outside of the ranges shown.
3. kWi input is for compressors only.
4. COP = Coefficient of Performance (kWo/total kW). Total kW include compressors and control power.
5. Ratings are based on an evaporator temperature drop of 5.6°C.
6. Interpolation between points is permissible. Extrapolation is not permitted.
7. Rated in accordance with ARI Standard 550/590-98.

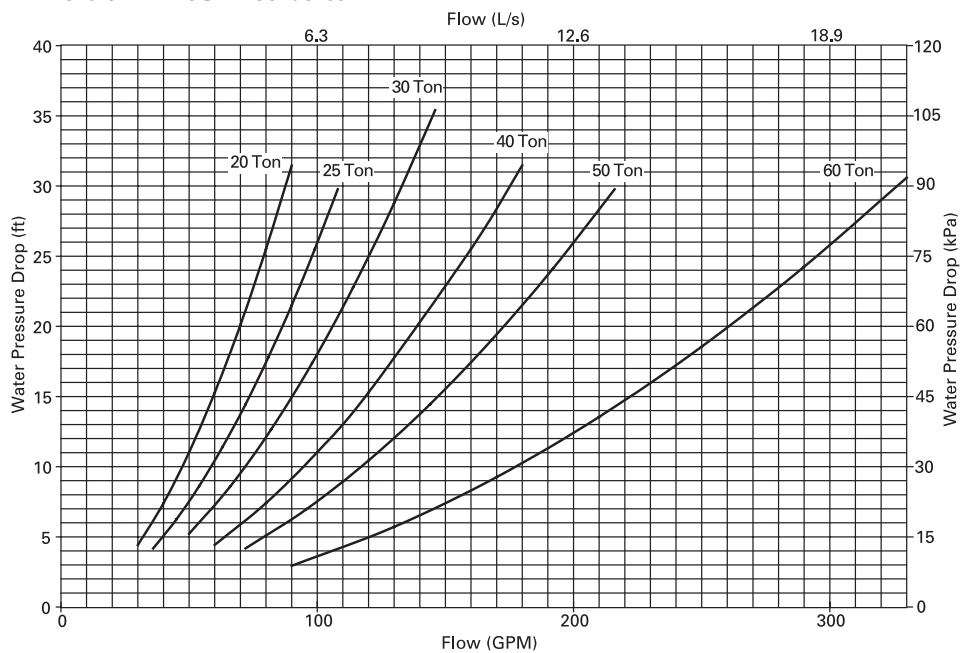
# Performance Data

# Pressure Drops

**Chart PD-1 – CGWE Evaporator**



**Chart PD-2 – CGWE Condenser**





# Electrical Data

**Table E-1 - Electrical Data for CGWE Water-Cooled Chillers**

Unit Size	Unit Wiring Data				Quantity	Compressor		Controls
	Rated Voltage	Minimum Circuit Ampacity	Maximum Fuse Size	Recommended Dual Element Fuse Size		RLA Each	LRA Each	kW
20	200-230/60	77	110	90	2-10	34	251	0.16
	380/60	39	50	45		17	142	0.16
	460/60	32	45	35		14	117	0.16
	575/60	29	40	35		13	94	0.16
	400/50	41	50	45		18	110	0.16
25	200-230/60	99	150	125	1-10 1-15	52/34	376/251	0.16
	380/60	51	70	60		27/17	215/142	0.16
	460/60	43	60	50		23/14	178/117	0.16
	575/60	36	50	40		18/13	143/94	0.16
	400/50	52	70	60		27/18	174/110	0.16
30	200-230/60	117	150	150	2-15	52	376	0.16
	380/60	61	80	70		27	215	0.16
	460/60	52	70	60		23	178	0.16
	575/60	41	50	45		18	143	0.16
	400/50	61	80	70		27	174	0.16
40	200-230/60	145	175	175	4-10	34	251	0.24
	380/60	73	80	80		17	142	0.24
	460/60	60	70	70		14	117	0.24
	575/60	55	60	60		13	94	0.24
	400/50	77	90	90		18	110	0.24
50	200-230/60	185	225	200	2-10 2-15	52/34	376/251	0.24
	380/60	95	125	110		27/17	215/142	0.24
	460/60	80	100	90		23/14	178/117	0.24
	575/60	67	80	80		18/13	143/94	0.24
	400/50	97	110	110		27/18	174/110	0.24
60	200-230/60	221	250	250	4-15	52	376	0.24
	380/60	115	125	125		27	215	0.24
	460/60	98	110	110		23	178	0.24
	575/60	77	90	90		18	143	0.24
	400/50	115	125	125		27	174	0.24

**Notes:**

1. Minimum circuit ampacity is 125% of the largest compressor RLA, plus 100% of the remaining compressor(s) RLA, per NEC 440-32 and NEC 440-33.
2. Maximum fuse size is 225% of the largest compressor RLA, plus 100% of the remaining compressor(s) RLA, per NEC 440-33.
3. Recommended dual element fuse size is 150% of the largest compressor RLA, plus 100% of remaining compressor(s) RLA, per NEC 440-33.
4. Use copper conductors only.
5. Voltage Utilization Range:

Rated Voltage	Utilization Range
200-230/60	180-253
380/60	342-418
460/60	414-506
575/60	517-633
400/50	360-440
6. Local codes may take precedence.
7. If unit is ordered with the High Condenser Entering Water Temperature Range (90-130), use CCAD electrical information.



# Electrical Data

**Table E-2 - Electrical Data for High Temperature Condenser CGWE Chillers and CCAD Compressor-Chillers**

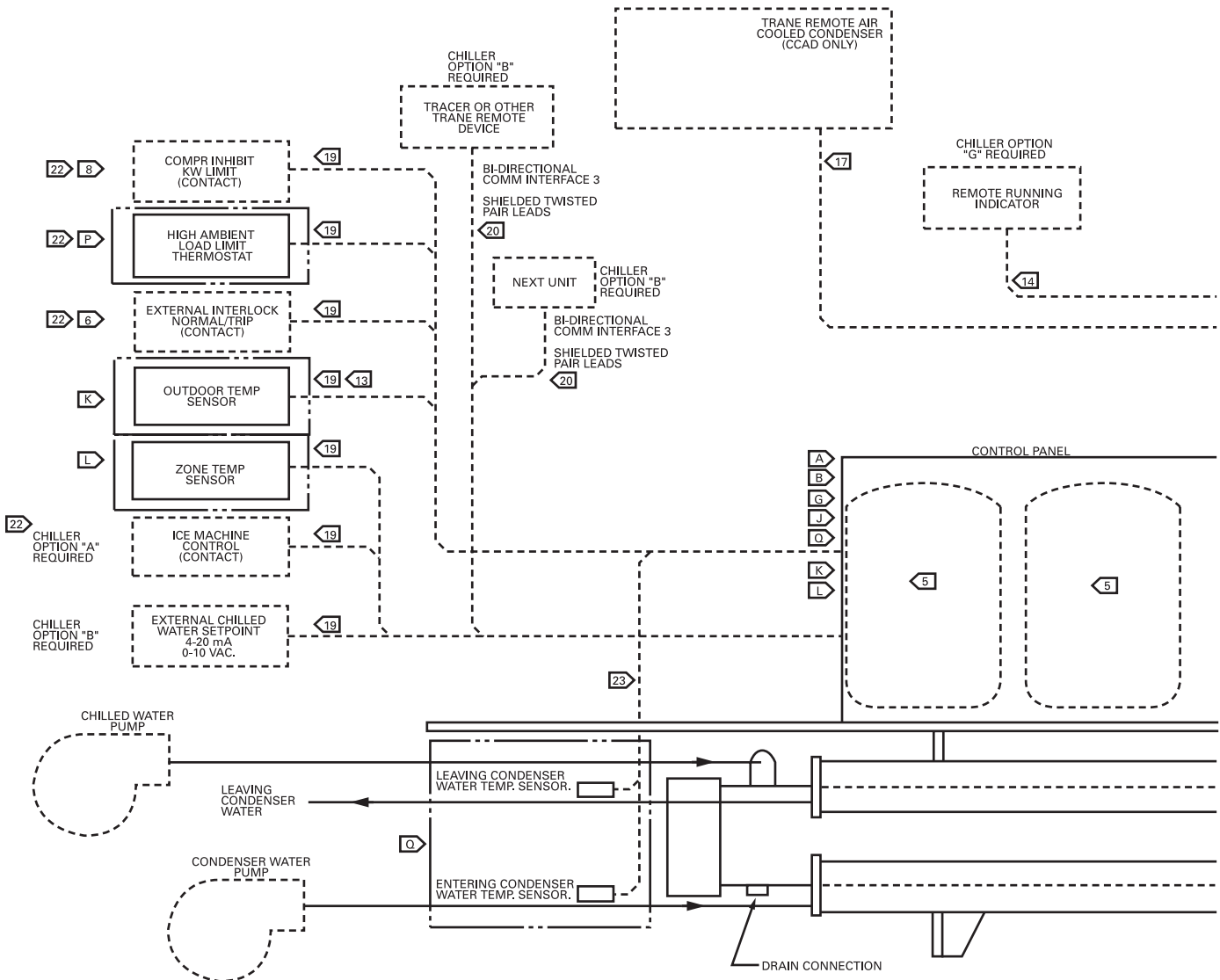
Unit Size	Unit Wiring Data				Quantity	Compressor		Controls
	Rated Voltage	Minimum Circuit Ampacity	Maximum Fuse Size	Recommended Dual Element Fuse Size		RLA Each	LRA Each	kW
20	200-230/60	88	125	100	2-10	39	251	0.16
	380/60	45	60	50		20	142	0.16
	460/60	39	50	45		17	117	0.16
	575/60	32	45	35		14	94	0.16
25	200-230/60	112	150	150	1-10	58/39	376/251	0.16
	380/60	59	80	70		31/20	215/142	0.16
	460/60	50	70	60	1-15	26/17	178/117	0.16
	575/60	41	60	50		21/14	143/94	0.16
30	200-230/60	131	175	150	2-15	58	376	0.16
	380/60	70	100	80		31	215	0.16
	460/60	59	80	70		26	178	0.16
	575/60	48	60	60		21	143	0.16
40	200-230/60	166	200	200	4-10	39	251	0.24
	380/60	85	100	90		20	142	0.24
	460/60	73	80	80		17	117	0.24
	575/60	60	70	70		14	94	0.24
50	200-230/60	209	250	225	2-10	58/39	376/251	0.24
	380/60	110	125	125		31/20	215/142	0.24
	460/60	93	110	100	2-15	26/17	178/117	0.24
	575/60	76	90	90		21/14	143/94	0.24
60	200-230/60	247	300	300	4-15	58	376	0.24
	380/60	132	150	140		31	215	0.24
	460/60	111	125	125		26	178	0.24
	575/60	90	110	100		21	143	0.24

**Notes:**

- Minimum circuit ampacity is 125% of the largest compressor RLA, plus 100% of the remaining compressor(s) RLA, per NEC 440-32 and NEC 440-33.
- Maximum fuse size is 225% of the largest compressor RLA, plus 100% of the remaining compressor(s) RLA, per NEC 440-33.
- Recommended dual element fuse size is 150% of the largest compressor RLA, plus 100% of remaining compressor(s) RLA, per NEC 440-33.
- Use copper conductors only.
- Voltage Utilization Range:

Rated Voltage	Utilization Range
200-230/60	180-253
380/60	342-418
460/60	414-506
575/60	517-633
400/50	360-440
- Local codes may take precedence.
- If unit is ordered with the High Condenser Entering Water Temperature Range (90-130), use CCAD electrical information.

# Jobsite Connections

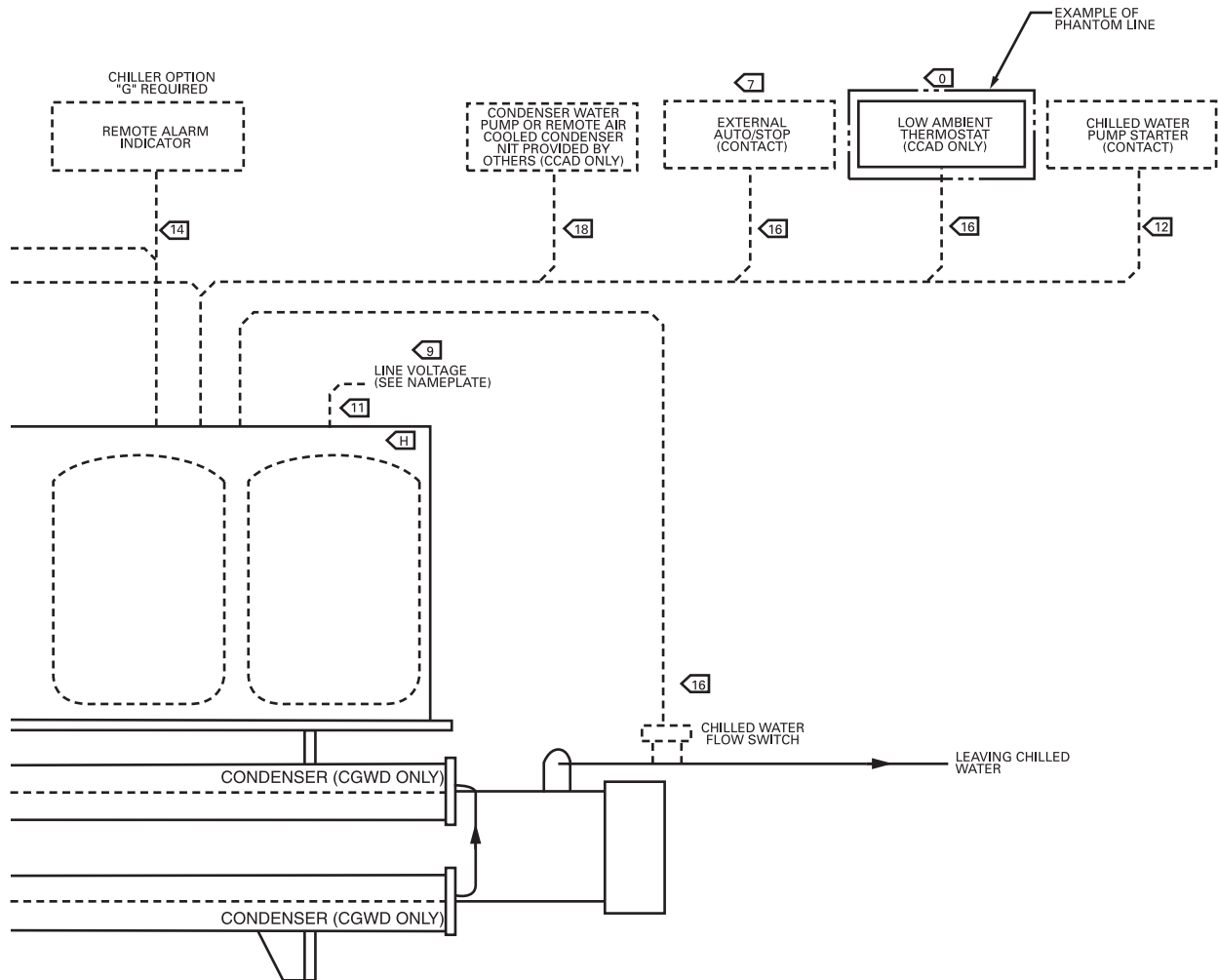


**NOTES:**

- DASHED LINES INDICATE RECOMMENDED FIELD WIRING BY OTHERS. PHANTOM LINES INDICATE ALTERNATE CIRCUITRY OR AVAILABLE SALES OPTION. CHECK SALES ORDER TO DETERMINE IF WIRING IS REQUIRED FOR SPECIFIC OPTIONS.
  - ALL THREE PHASE MOTORS SUPPLIED WITH THE UNIT ARE PROTECTED UNDER PRIMARY SINGLE PHASE FAILURE CONDITIONS.
  - CAUTION - DO NOT ENERGIZE UNIT UNTIL CHECK OUT AND START-UP PROCEDURES HAVE BEEN COMPLETED.
  - THE FOLLOWING CAPABILITIES ARE OPTIONAL - THEY ARE IMPLEMENTED AND WIRED AS REQUIRED FOR A SPECIFIC SYSTEM APPLICATION.
- ◁ A ICE-MACHINE CONTROL
  - ◁ B COMMUNICATIONS INTERFACE
  - ◁ G REMOTE RUNNING INDICATION AND ALARM CONTACTS
  - ◁ H UNIT DISCONNECT, NON-FUSED
  - ◁ J CHILLED WATER RESET - RETURN WATER
  - ◁ K CHILLED WATER RESET - OUTDOOR AIR TEMP. SENSOR OPTIONAL ON CGWE AND STANDARD ON CCAD.
  - ◁ L CHILLED WATER RESET - ZONE AIR
  - ◁ O LOW AMBIENT THERMOSTAT
  - ◁ P HIGH AMBIENT LOAD LIMIT THERMOSTAT
  - ◁ Q ENTERING AND LEAVING CONDENSER WATER TEMP. SENSOR. MATCHED PAIR OF THERMISTORS. SENSOR KIT SHIPPED WITH UNIT AND FACTORY INSTALLED.

- ◁ 5 NOT USED ON 20-30 TON UNITS.
- ◁ 6 AUXILIARY CONTROLS FOR A CUSTOMER SPECIFIED OR INSTALLED LATCHING TRIPOUT. THE CHILLER WILL RUN NORMALLY WHEN THE CONTACT IS CLOSED AND TRIP THE CHILLER OFF ON MANUALLY RESETTABLE DIAGNOSTIC WHEN THE CONTACT OPENS. MANUAL RESET IS ACCOMPLISHED AT THE CHILLER SWITCH ON THE FRONT OF THE UNIT CONTROL MODULE (UCM).
- ◁ 7 AUXILIARY CONTROLS FOR A CUSTOMER SPECIFIED OR INSTALLED REMOTE AUTO/STOP FUNCTION. THE CHILLER WILL RUN NORMALLY WHEN THE CONTACT IS CLOSED AND STOP THE CHILLER WHEN THE CONTACT IS OPEN. RE-CLOSURE OF THE CONTACT WILL PERMIT THE CHILLER TO AUTOMATICALLY RETURN TO NORMAL OPERATION.
- ◁ 8 AUXILIARY CONTROLS FOR A CUSTOMER SPECIFIED OR INSTALLED DEMAND LIMIT FUNCTION. THE CHILLER WILL RUN NORMALLY WHEN THE CONTACT IS CLOSED AND LIMIT CHILLER OPERATION TO ONE COMPRESSOR PER CIRCUIT WHEN THE CONTACT OPENS. RE-CLOSURE OF THE CONTACT WILL PERMIT THE CHILLER TO AUTOMATICALLY RETURN TO NORMAL OPERATION.

# Jobsite Connections



#### WIRING:

◁10 ALL FIELD WIRING MUST BE IN ACCORDANCE WITH THE NATIONAL ELECTRICAL CODE (NEC), STATE, AND LOCAL REQUIREMENTS. OUTSIDE THE UNITED STATES, OTHER COUNTRIES APPLICABLE NATIONAL AND/OR LOCAL REQUIREMENTS SHALL APPLY.

#### REQUIRED WIRING:

- ◁11 COPPER WIRE ONLY - SIZED PER N.E.C. - BASED ON NAMEPLATE RLA. SEE CUSTOMER WIRE SELECTION TABLE.
- ◁12 2 WIRES, 115 VAC CIRCUIT. MINIMUM CONTACT RATING AT 115 VAC - 6.9 VA INRUSH, 1.3 VA SEALED.
- ◁13 CCAD UNITS WITH AIR COOLED CONDENSER ONLY. 2 WIRES, 30 VOLT OR LESS CIRCUIT. DO NOT RUN IN CONDUIT WITH HIGHER VOLTAGE CIRCUITS. SEE CUSTOMER WIRE SELECTION TABLE.

#### OPTIONAL WIRING:

- ◁14 3 WIRES, 115 VAC CIRCUIT. SEPARATE 115 VAC POWER SUPPLY IS REQUIRED. LOAD NOT TO EXCEED 115 VA SEALED, 1150 VA INRUSH.
- ◁16 2 WIRES, 115 VAC CIRCUIT. MINIMUM CONTACT RATING AT 115 VAC - 6.9 VA INRUSH, 1.3 VA SEALED.
- ◁17 3 WIRES ON 20-30 TON UNITS, 6 WIRES ON 40-60 TON UNITS, 115 VAC CIRCUIT. SEPARATE 115 VAC POWER SUPPLY REQUIRED. LOAD NOT TO EXCEED 115 VA SEALED, 1150 VA INRUSH.
- ◁18 2 WIRES, 115 VAC CIRCUIT. SEPARATE 115 VAC POWER SUPPLY IS REQUIRED. LOAD NOT TO EXCEED 1150 VA INRUSH, 115 VA SEALED.
- ◁19 2 WIRES, 30 VOLT OR LESS CIRCUIT. DO NOT RUN IN CONDUIT WITH HIGHER VOLTAGE CIRCUITS. SEE CUSTOMER WIRE SELECTION TABLE.
- ◁20 SHIELDED TWISTED PAIR, 30 V OR LESS CIRCUIT. MAXIMUM LENGTH 5000 FT. DO NOT RUN IN CONDUIT WITH HIGHER VOLTAGE WIRE. SEE CUSTOMER WIRE SELECTION TABLE.
- ◁22 CUSTOMER SUPPLIED CONTACTS MUST BE COMPATIBLE WITH DRY CIRCUIT 12 VDC, 45 mA RESISTIVE LOAD. SILVER OR GOLD PLATED CONTACTS ARE RECOMMENDED.
- ◁23 SENSOR LEADS TO REACH CONTROL PANEL. 30 VOLT OR LESS CIRCUIT. DO NOT RUN IN CONDUIT WITH HIGHER VOLTAGE CIRCUITS.

# Controls

---

A microcomputer-based controller controls the CGWE and CCAD scroll chiller. The microcomputer controller provides better control than past controls with several new, important benefits.

### **Customized Control**

The microcomputer-based controller allows Trane to customize controls around the chiller application and the specific components used in the scroll chiller. For instance, the compressor protection system is specifically designed for the Trane scroll compressor. The leaving chilled water temperature control algorithm maintains accurate temperature control, minimizes the drift from set point and provides better building comfort. The microcomputer control incorporates improved chiller start-up, load limiting, compressor anti-recycle timing and lead/lag functions into standard chiller operation.

### **Simple Interface with Other Control Systems**

Microcomputer controls afford simple interface with other control systems, such as time clocks, building automation systems and ice storage systems. Wiring to the unit can be as simple as two wires! You can have the flexibility to meet job requirements without learning a complicated control system.

### **Safety Controls**

A centralized microcomputer offers a higher level of machine protection. Since the safety controls are smarter, compressor operation can be limited to avoid compressor or evaporator failures, minimizing nuisance shutdown. For instance, if the head pressure on a unit is approaching the trip point, the controller will turn off a compressor and display an alarm to indicate a head pressure problem. This keeps cooling capacity available until the problem can be solved. Whenever possible, the chiller is allowed to perform its function: make chilled water. In addition, microcomputer controls allow for more types of protection as standard, such as over and under voltage! Overall, the safety controls help keep the building running and out of trouble.

### **Monitoring and Diagnostics**

The microcomputer provides all control functions and can easily indicate such parameters as leaving chilled water temperature and capacity stage. If a failure does occur, one of over 40 individual diagnostic codes will be used to indicate the problem, giving more specific information about the failure. The repair of the unit can occur in a shorter period of time. All of the monitoring and diagnostic information is displayed directly on a microcomputer display.

### **Interface with the Trane Integrated Comfort™ System (ICS)**

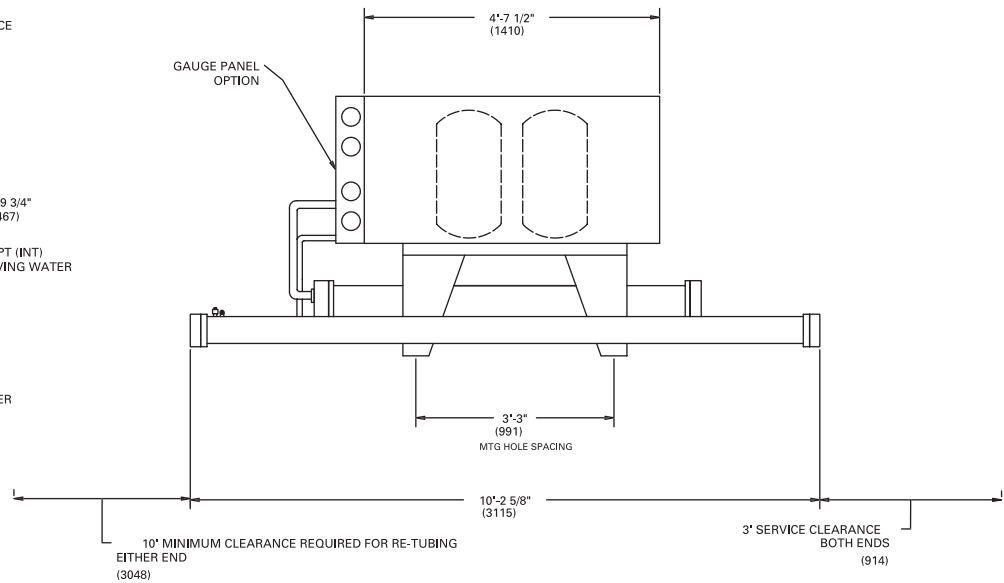
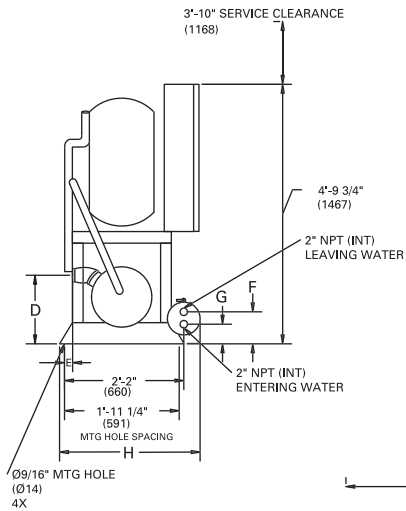
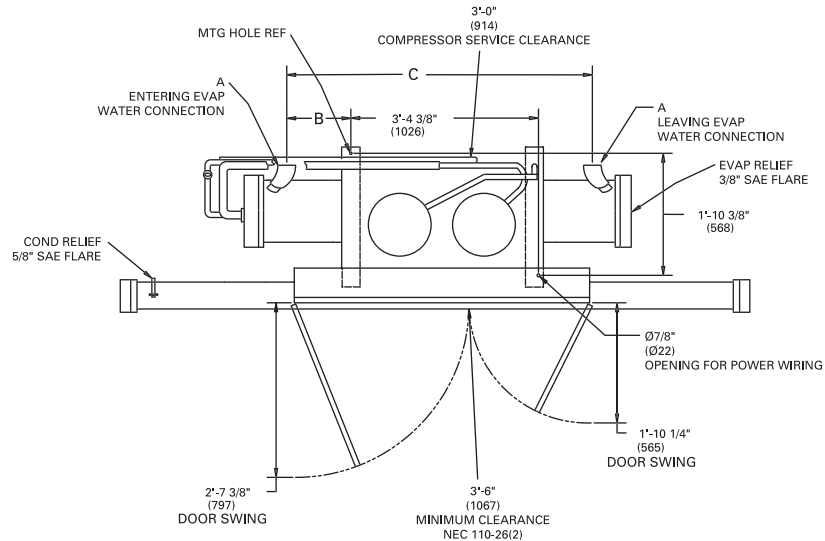
When the scroll chiller is used in conjunction with a Trane Tracer™ system, the unit can be monitored and controlled from a remote location. The scroll chiller can be controlled to fit into the overall building control strategy by using auto/stop, compressor inhibit and chilled water reset functions.

All of the monitoring information indicated on the microcomputer can be read off the Tracer system display. In addition, all the powerful diagnostic information can be read back at the Tracer system.

Best of all, this powerful capability comes over a single twisted pair of wires!

# Dimensional Data

## CGWE 20-30 Ton

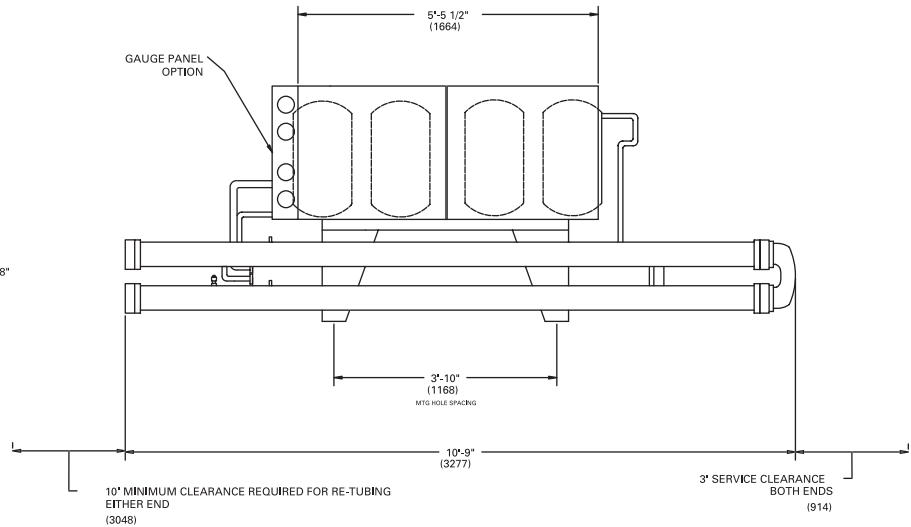
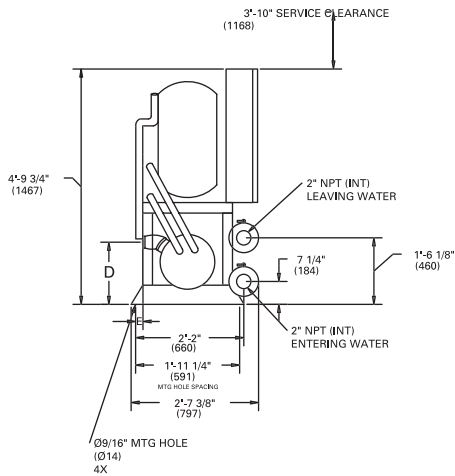
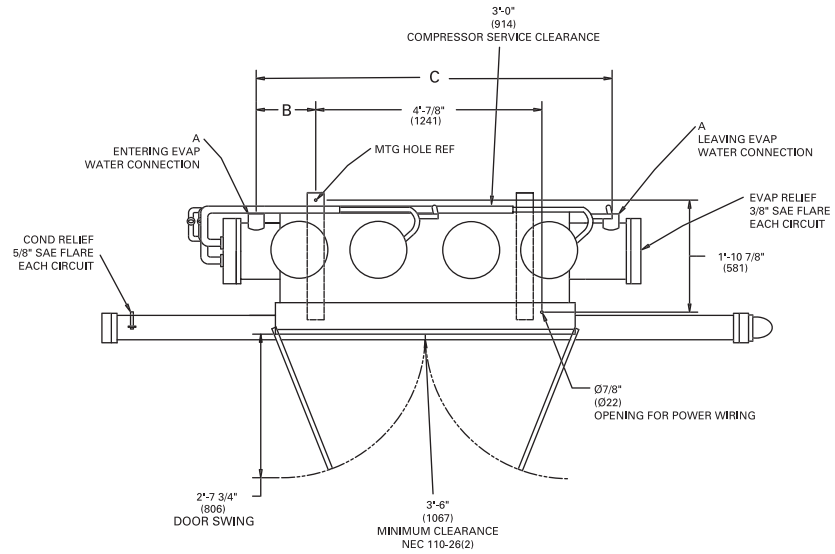


Size	A	B	C	D	E	F	G	H
20 Ton	2" (51)	8 1/2" (216)	4'-8" (1423)	1'-3 3/8" (391)	4 1/8" (105)	8 5/8" (218)	5 5/8" (143)	2' 7 3/8" (797)
25 Ton	2" (51)	8 1/2" (216)	4'-8" (1423)	1'-3 3/8" (391)	4 1/8" (105)	8 5/8" (218)	5 5/8" (143)	2' 7 3/8" (797)
30 Ton	2 1/2" (64)	7 3/4" (197)	4'-6 1/2" (1384)	1'-5 3/8" (441)	2 1/4" (57)	12" (305)	8" (203)	2' 8 3/16" (818)

- Notes:
- Dimensions in ( ) are in millimeters.
  - Dimensional tolerance  $\pm 1/4"$  (3).

# Dimensional Data

# CGWE 40-50 Ton

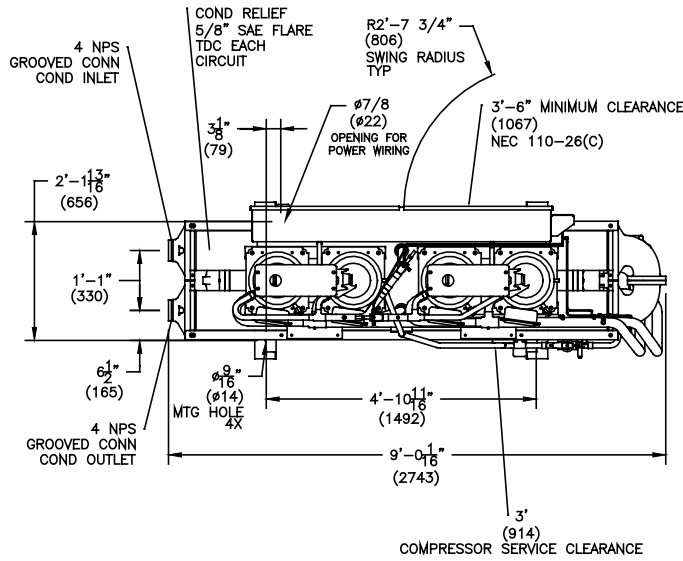


Size	A	B	C	D	E
40 Ton	2 1/2" (64)	1'-3 3/4" (400)	6'-5 1/2" (1968)	1'-4 1/4" (413)	4 3/8" (111)
50 Ton	3" (76)	1'-3 1/2" (394)	6'-5" (1956)	1'-6 1/8" (480)	2 1/2" (64)

- Notes:
1. Dimensions in ( ) are in millimeters.
  2. Dimensional tolerance  $\pm 1/4"$  (3).

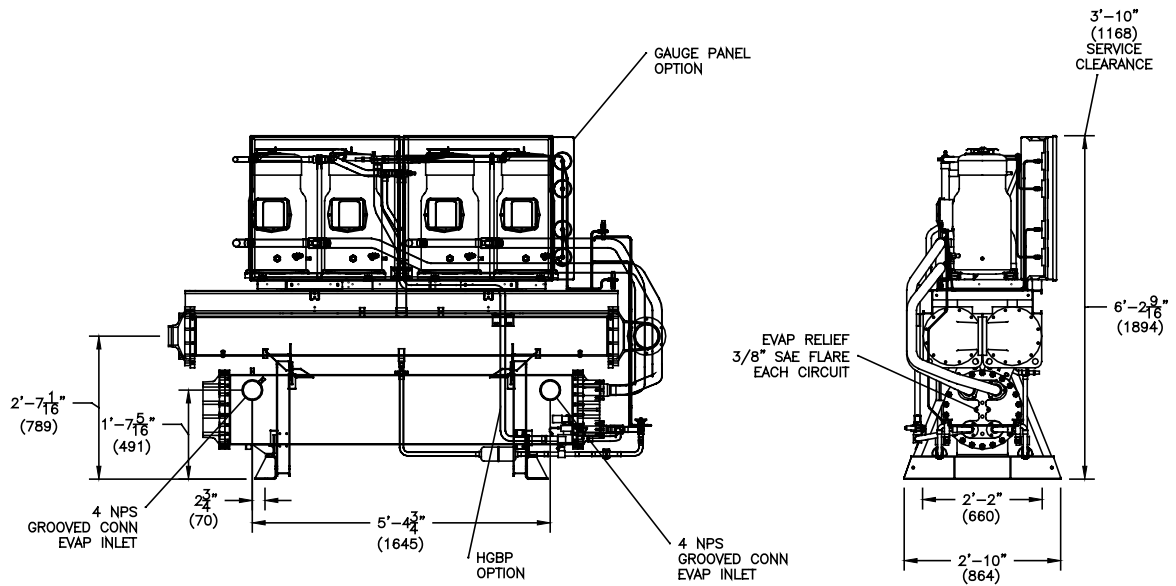
# Dimensional Data

# CGWE 60 Ton



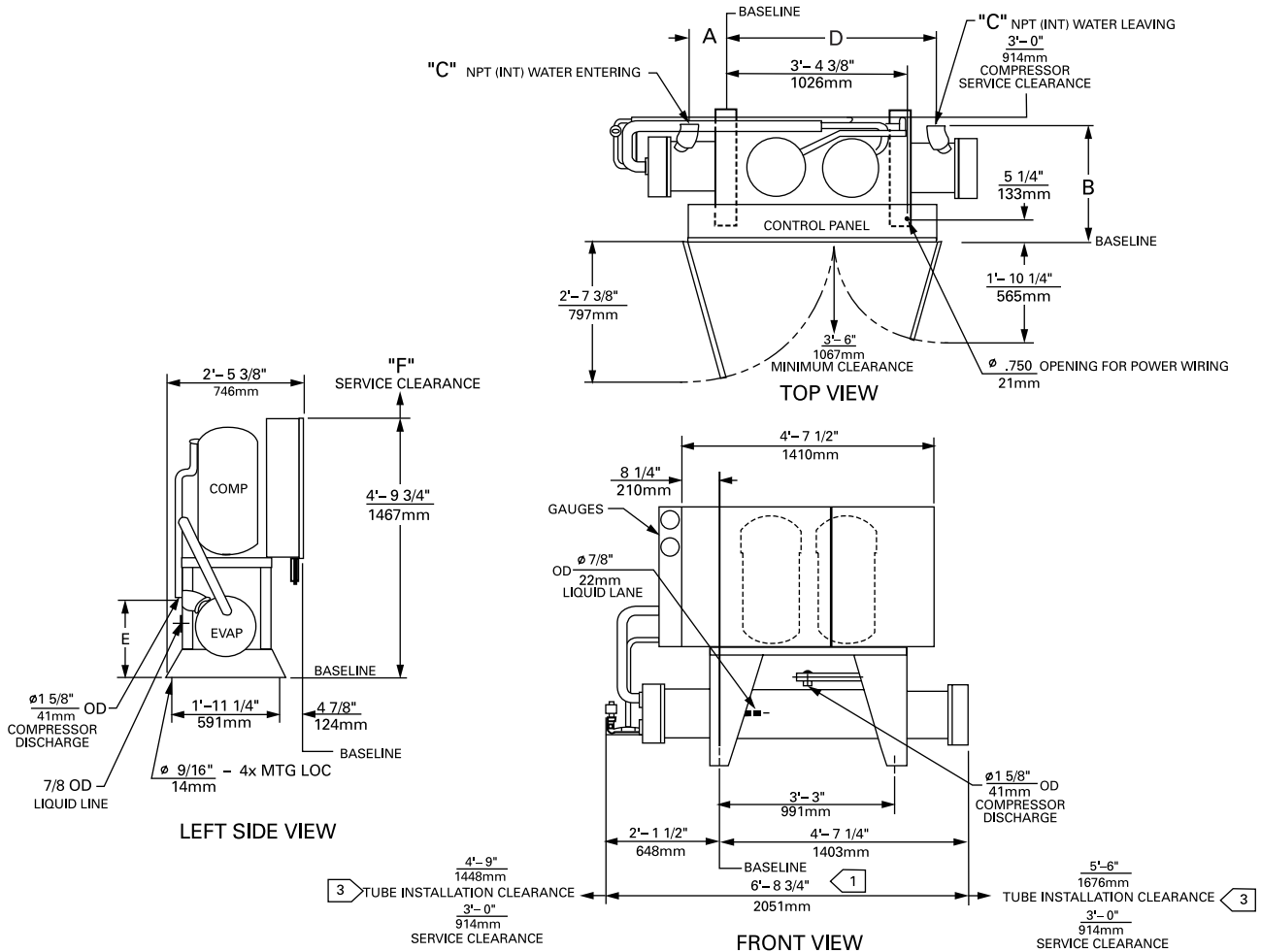
NOTES:

1. DIMENSIONS IN ( ) ARE MILLIMETERS
2. DIMENSIONAL TOLERANCE ±1/8" (3)



# Dimensional Data

# CCAD 20-30 Ton



Unit Size	English Dimensions					
	A	B	C	D	E	F
20 Ton	8 1/2"	3'-11 1/2"	2"	2'-0"	1'-3 1/2"	3'-3"
25 Ton	8 1/2"	3'-11 1/2"	2"	1'-11 3/4"	1'-3 1/2"	3'-10"
30 Ton	7 3/4"	3'-10 3/4"	2 1/2"	2'-1 7/8"	1'-5 3/8"	3'-10"

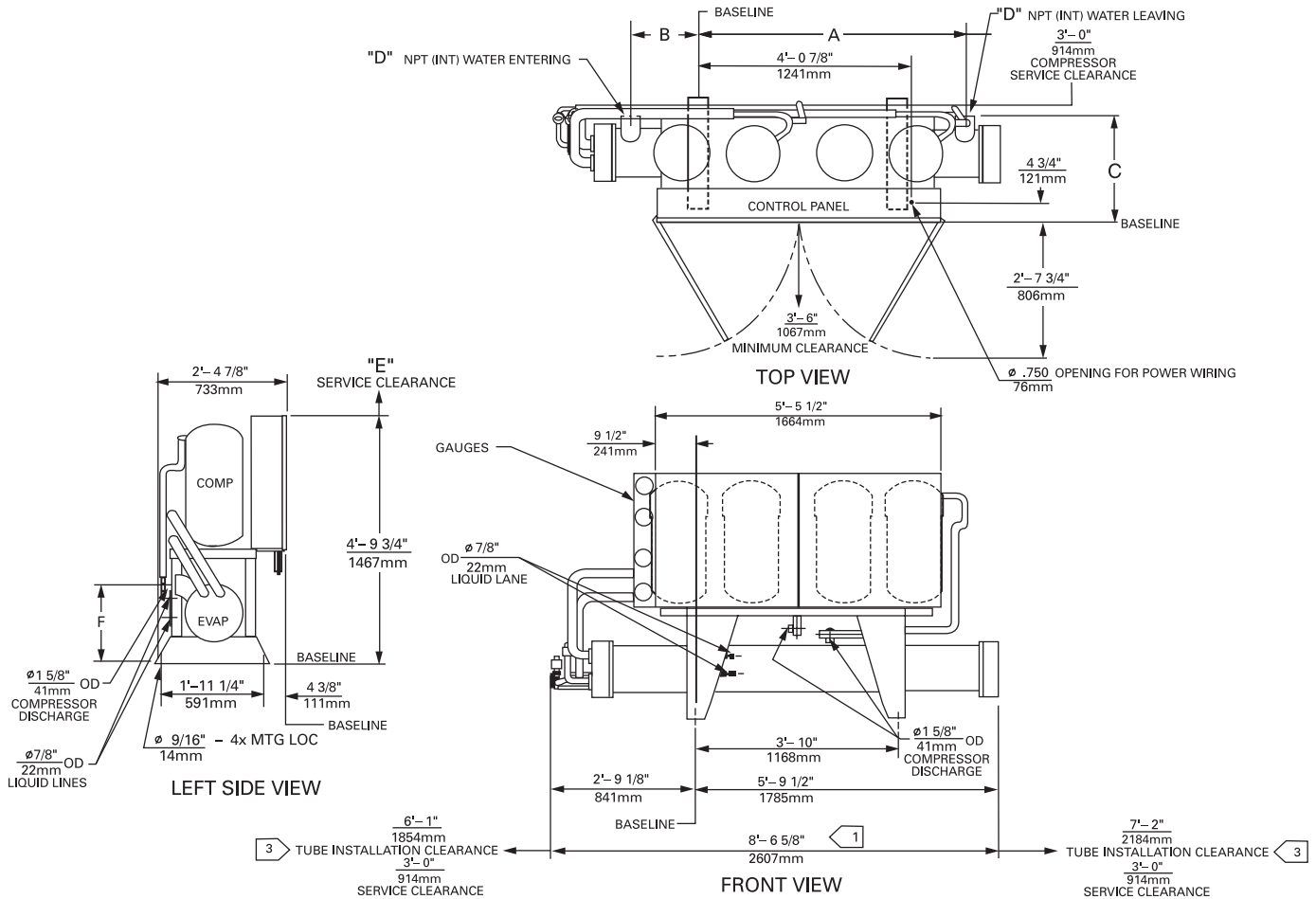
Unit Size	Metric Dimensions (mm)					
	A	B	C	D	E	F
20 Ton	216	1207	51	610	394	1041
25 Ton	216	1207	51	603	394	1041
30 Ton	197	1187	64	657	441	1168

- Notes:
1. Add 3/4" (19 mm) for units with insulation.
  2. Dimensional tolerance ± 1/4" (3 mm).
  3. Tube installation at either end of evaporator.



# Dimensional Data

# CCAD 40-60 Ton



Unit Size	English Dimensions					
	A	B	C	D	E	F
40 Ton	5'-1 3/4"	1'-3 3/4"	1'-11 1/4"	2 1/2"	3'-5"	1'-4 1/4"
50 Ton	5'-1 1/2"	1'-3 1/2"	2'-1 1/8"	3"	3'-10"	1'-6 1/8"
60 Ton	5'-1 1/2"	1'-3 1/2"	2'-0 7/8"	3"	3'-10"	1'-6 1/8"

Unit Size	Metric Dimensions (mm)					
	A	B	C	D	E	F
40 Ton	1568	400	591	64	1041	413
50 Ton	1562	394	638	76	1168	480
60 Ton	1562	394	632	76	1168	460

- Notes:
- Add 3/4" (19 mm) for units with insulation.
  - Dimensional tolerance ± 1/4" (3 mm).
  - Tube installation at either end of evaporator.

# Weights

**Table W-1 – Weights, CGWE Chillers**

Unit		20	25	30	40	50	60
Operating Wt.	(lb.)	1454	1517	2009	2506	2727	3753
	(kg)	660	689	912	1138	1238	1704
Shipping Wt.	(lb.)	1282	1360	1774	2126	2376	3224
	(kg)	582	618	806	965	1079	1464

**Table W-2 – Weights, CCAD Compressor-Chillers**

Unit		20	25	30	40	50	60
Operating Wt.	(lb.)	1004	1079	1274	1509	1808	1982
	(kg)	456	490	579	685	821	900
Shipping Wt.	(lb.)	1430	1605	1836	1792	2166	2494
	(kg)	649	729	834	814	984	1133

# Options

---

## Options

**Hot Gas Bypass:** Hot gas bypass option allows unit operation below the minimum step of unit unloading. The regulator valve, along with all associated refrigerant piping and electrical wiring, are factory installed and tested on one refrigeration circuit. Unit does not start in hot gas bypass mode. If the unit operates in bypass mode for 30 minutes without a call for cooling, it will pump down and shut off. Unit starts immediately upon a further call for cooling.

**Chilled Water Reset:** Front panel settable control, microprocessor based control strategy, and field-installed sensor for temperature based (ambient or zone) reset are included in this option. Return water reset sensor is standard, but panel controller and control strategy must be ordered as an option.

**Communications Interface:** Bi-directional (Trane ICS) and generic BAS (external chilled water setpoint) communication interfaces are available for external control applications.

**Remote Display Panel:** The remote panel has the same digital display that is on the unit control panel as well as an auto/stop switch. Another auto/stop switch can be wired from pump contactor or time clock (scheduling). Remote display is mutually exclusive with Trane ICS and generic BAS.

**Remote Running Indication and Alarm Contacts:** Two separate single pole/double throw contacts are provided to indicate when the compressors are running and if a unit failure has occurred. A failure will be indicated if the unit has a manual reset fault. A failure is not indicated on an automatic reset fault.

**Ice Making Controls:** In ice-making mode, the unit will operate fully loaded in response to jobsite supplied contact closure. Ice making will terminate when the return fluid temperature falls below an adjustable setpoint (minimum 20°F [-6.7°C]). When not in ice making mode, unit will provide modulating capacity control based on leaving chilled fluid temperature (20-55°F) [-6.7°C to 12.8°C].

**Cycle Counter and Hour Meter:** One cycle counter and hour meter per compressor.

**Unit Mounted Disconnect Switch:** Non-fused molded case disconnect switch factory installed in control panel for disconnecting main three-phase power.

**Isolators:** Neoprene-in-shear isolators for field installation under unit frame.

**Gauges:** Factory-installed gauges monitor suction and discharge pressure. One set of gauges per refrigeration circuit.

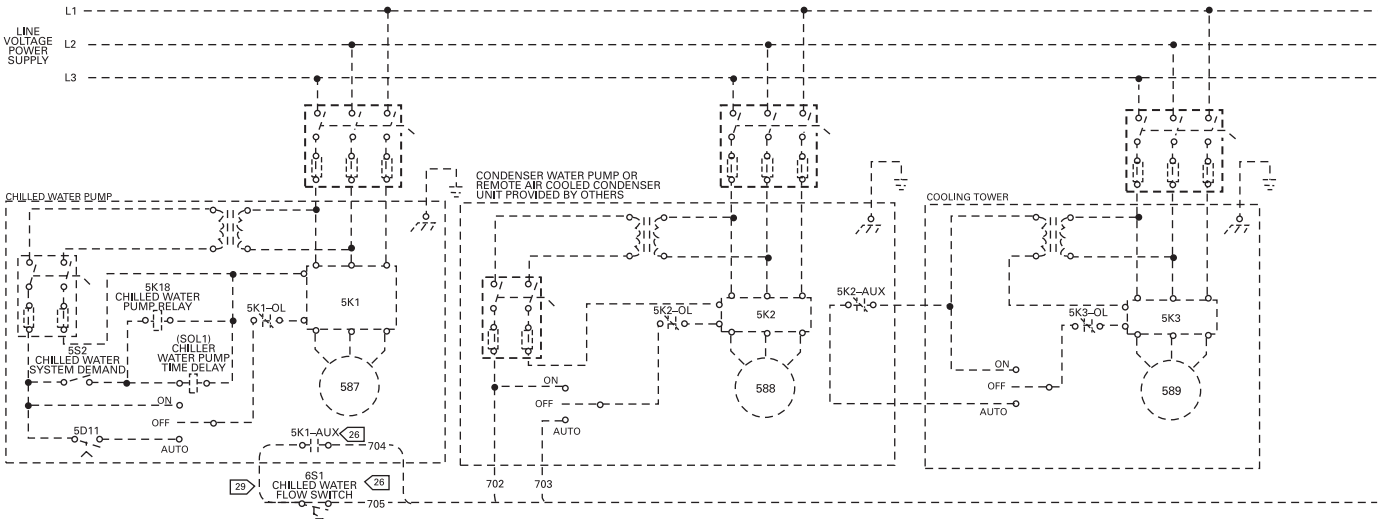
**Sound Attenuation:** Factory-installed acoustical attenuation for applications where extremely low sound level is required.

**Water Regulating Valves:** Field-installed valves provide means for control of head pressure.

**Low Ambient Thermostat:** Field-installed outdoor thermostat with an adjustable setpoint provides means for low ambient lockout.

**Condenser Water Temperature Sensor:** Field-installed matched pair temperature sensors provide for microprocessor display.

# Typical Wiring Diagrams



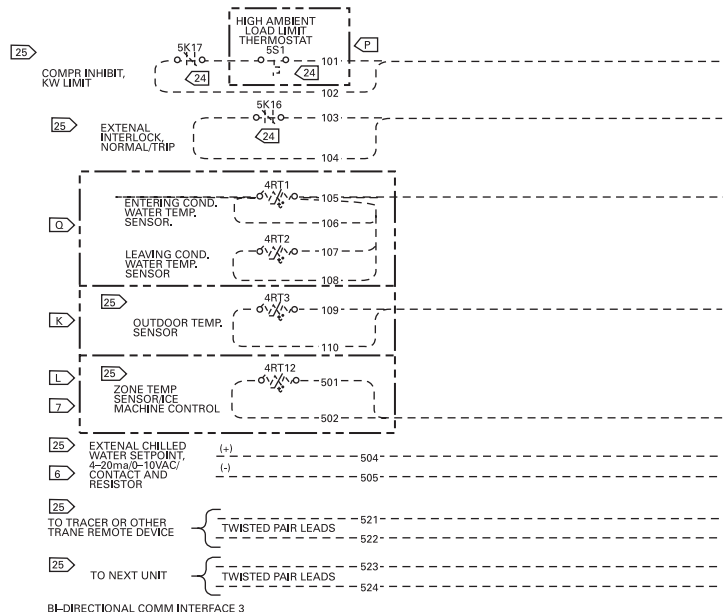
**NOTES:**

- DASHED LINES INDICATE RECOMMENDED FIELD WIRING BY OTHERS. PHANTOM LINES INDICATE ALTERNATE CIRCUITRY OR AVAILABLE SALES OPTION. CHECK SALES ORDER TO DETERMINE IF WIRING IS REQUIRED FOR SPECIFIC OPTIONS.
- ALL THREE PHASE MOTORS SUPPLIED WITH THE UNIT ARE PROTECTED UNDER PRIMARY SINGLE PHASE FAILURE CONDITIONS.
- CAUTION - DO NOT ENERGIZE UNIT UNTIL CHECK OUT AND START-UP PROCEDURES HAVE BEEN COMPLETED.
- USED ON 40, 50 AND 60 TON UNITS ONLY.
- SEE INSET "A" FOR PROGRAMMING RESISTOR CONNECTIONS. TO PROGRAM AN EXTERNAL CHILLED WATER SETPOINT WHEN A 4-20 mA/0-10 VDC SIGNAL IS NOT USED. SEE THE OPERATORS MANUAL FOR PROGRAMMING RESISTOR CONNECTIONS FOR USE ON NORMAL COOLING OR ICE MAKING APPLICATIONS.
- SEE INSET "C" FOR CONTACTS (IN PLACE OF ZONE TEMP. SENSOR) FOR OPTIONAL ICE MACHINE CONTROL.
- THE FOLLOWING CAPABILITIES ARE OPTIONAL - THEY ARE IMPLEMENTED AND WIRED AS REQUIRED FOR A SPECIFIC SYSTEM APPLICATION.

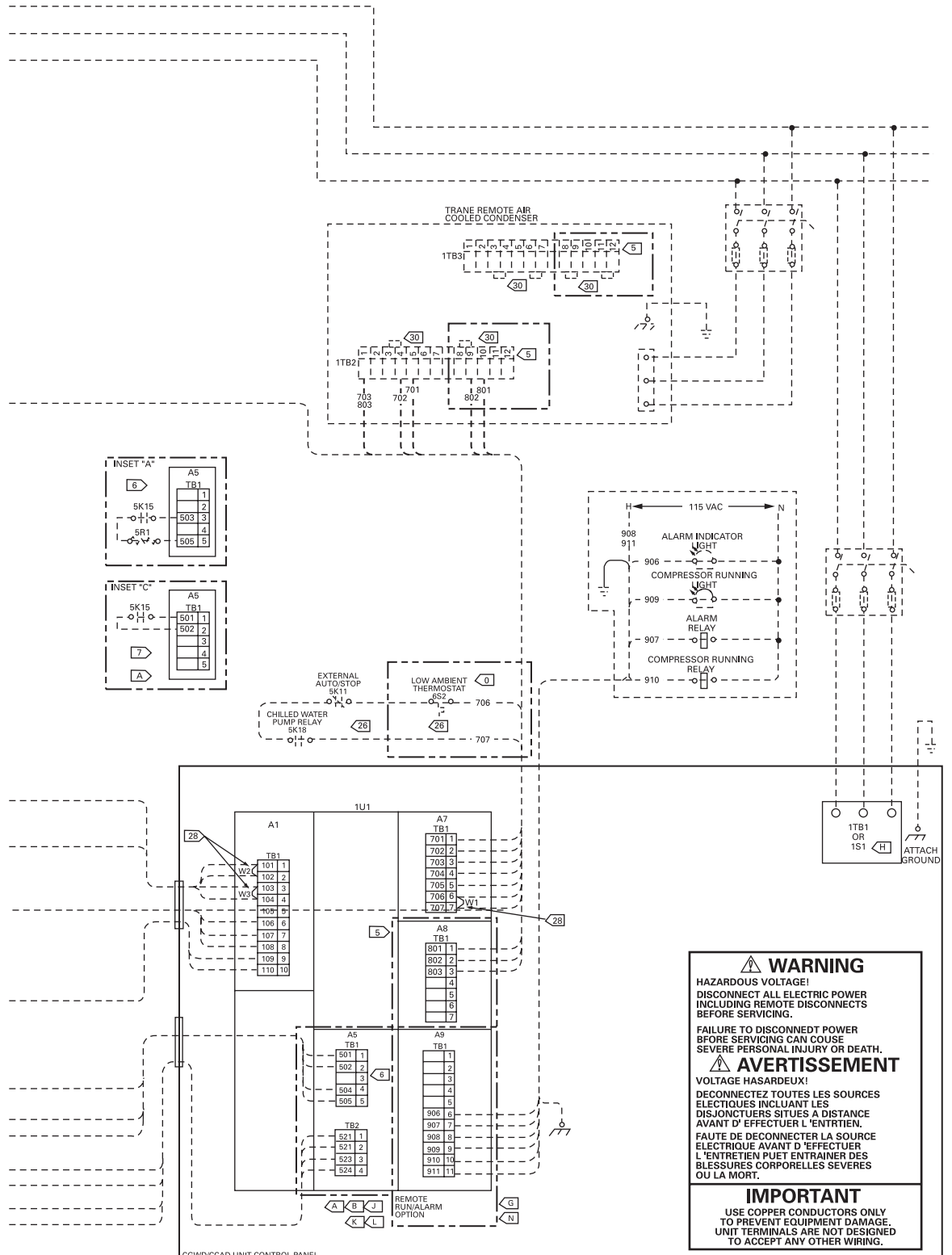
- <A> ICE-MACHINE CONTROL (CANNOT BE USED WITH OPT. L)
- <B> COMMUNICATIONS INTERFACE
- <G> REMOTE RUNNING INDICATION AND ALARM CONTACTS
- <H> UNIT DISCONNECT, NON-FUSED
- <J> CHILLED WATER RESET - RETURN WATER
- <K> CHILLED WATER RESET - OUTDOOR AIR TEMP. SENSOR OPTIONAL ON CGWE AND STANDARD ON CCAD.
- <L> CHILLED WATER RESET - ZONE AIR (CANNOT BE USED WITH OPT. A)
- <O> LOW AMBIENT THERMOSTAT
- <P> HIGH AMBIENT LOAD LIMIT THERMOSTAT
- <Q> ENTERING AND LEAVING CONDENSER WATER TEMP. SENSOR. MATCHED PAIR OF THERMISTOR FOR 4RT1 AND 4RT2.

**WIRING AND CONTACT REQUIREMENTS:**

- ALL FIELD WIRING MUST BE IN ACCORDANCE WITH THE NATIONAL ELECTRICAL CODE (NEC), STATE, AND LOCAL REQUIREMENTS. OUTSIDE THE UNITED STATES, OTHER COUNTRIES APPLICABLE NATIONAL AND/OR LOCAL REQUIREMENTS SHALL APPLY.
- CUSTOMER SUPPLIED CONTACTS MUST BE COMPATIBLE WITH DRY CIRCUIT 12 VDC, 45 mA RESISTIVE LOAD. SILVER OR GOLD PLATED CONTACTS ARE RECOMMENDED.
- 30 VOLT OR LESS CIRCUIT. DO NOT RUN IN CONDUIT WITH HIGHER VOLTAGE CIRCUITS. USE #14-18 AWG. SEE SELECTION TABLE.
- MINIMUM CONTACT RATING AT 115 VAC: 6.9 VA INRUSH, 6.9 V A SEALED.
- WHEN CUSTOMER INPUT IS REQUIRED, REMOVE JUMPER AND INSTALL CUSTOMER WIRING.
- LOSS OF CHILLED WATER FLOW PROTECTION IS PROVIDED BY THE UNIT WITHOUT THE NEED FOR A CHILLED WATER FLOW SWITCH. THE USE OF A CHILLED WATER FLOW SWITCH IS AT THE CUSTOMER'S DISCRETION.
- FAN STAGING IS CONTROLLED BY THE COMPRESSOR CHILLER. TO INSURE PROPER FAN OPERATION ADD JUMPER TERMINALS ON 1TB3 AS SHOWN. REMOVE JUMPER FROM 1TB2-4 TO 1TB2-3 ON ALL CAUC UNITS. REMOVE JUMPER FROM 1TB2-9 TO 1TB2-8 ON ALL 40, 50 AND 60 TON CAUC UNITS. IF LOW AMBIENT OPTION, ADD JUMPER FROM 1TB3-6 TO 1TB3-7 AND FROM 1TB3-11 TO 1TB3-12.



# Typical Wiring Diagrams



**WARNING**  
HAZARDOUS VOLTAGE!  
DISCONNECT ALL ELECTRIC POWER INCLUDING REMOTE DISCONNECTS BEFORE SERVICING.

FAILURE TO DISCONNECT POWER BEFORE SERVICING CAN CAUSE SEVERE PERSONAL INJURY OR DEATH.

**AVERTISSEMENT**  
VOLTAGE HASARDEUX!  
DECONNECTEZ TOUTES LES SOURCES ELECTRIQUES INCLUNT LES DISJONCTEURS SITUES A DISTANCE AVANT D' EFFECTUER L'ENTRIEN.

FAUTE DE DECONNECTER LA SOURCE ELECTRIQUE AVANT D' EFFECTUER L'ENTRIEN PUEUT ENTRAINER DES BLESSURES CORPORELLES SEVERES OU LA MORT.

**IMPORTANT**  
USE COPPER CONDUCTORS ONLY TO PREVENT EQUIPMENT DAMAGE. UNIT TERMINALS ARE NOT DESIGNED TO ACCEPT ANY OTHER WIRING.



# Features Summary

---

## Advanced Design for Efficiency and Reliability

- Trane scroll compressor has 64 percent fewer parts than equal capacity reciprocating compressors for greater reliability. Part load efficiency is unmatched by any reciprocating compressor.
  - Factory installed microprocessor controls provides accurate chilled water temperature control. The microprocessor also incorporates optimal start-up logic, load limiting, compressor anti-recycle timing, automatic lead-lag function and compressor protection features.
  - Easy operation provided by menu-driven digital display. Display provides temperatures, pressures, setpoints and over 40 diagnostic readouts.
  - Compressor protection from start and run overloads, under and over voltage, phase loss and phase reversal, and rapid recycling.
  - Easy installation through small size, factory wiring, easy lifting provisions and start-up control logic.
  - Availability. Trane has the industry's fastest ship cycles on both stock and built-to-order units.
- Other standard features include:
    - Control power transformer
    - Auto lead-lag (on or off)
    - Solid-state motor protection
    - Insulation
    - Condenser water pump interlock
    - Filter-dryer
    - Built-in loss of chilled water flow sensors
    - Chillers fit through standard single-width door
  - Options
    - Trane Integrated Comfort™ systems communication
    - Generic building automation systems (BAS) interface
    - Chilled water reset (ambient, zone, return)
    - Unit mounted disconnect
    - Ice making
    - Hot gas bypass
    - Remote display/control panel
    - Remote running indication and alarm contact
    - Gauges
    - Sound attenuation
    - Neoprene isolators
    - Compressor cycle counter/hour meter
    - Water regulating valves
    - Condenser water temperature sensors

# Mechanical Specifications

---

## Water-Cooled Liquid Chillers and Compressor Chillers CGWE and CCAD Models 20 to 60 Tons

### General

All scroll chillers are factory tested and monitored for power and control operation (CGWE only). CGWE units ship with a full operating charge of refrigerant and oil. Exposed surfaces are painted with an air-dry beige primer-finisher prior to shipment.

### Compressor-Motor

Direct-drive, hermetic, 3600 rpm, 60 Hz [300 rpm, 60 Hz] fixed compression, scroll compressors (20 to 30 tons - two compressors; 40 to 60 tons - four compressors). Each compressor has: centrifugal oil pump, oil level sightglass, oil charging valve, two point lubrication for each motor bearing, flooded lubrication for the journal and thrust bearings, and a check valve on the scroll discharge port.

Motor is suction gas-cooled, hermetically sealed, two-pole, squirrel cage induction type.

### Evaporator

Shell and tube design with seamless copper tubes roller expanded into tube sheets. Designed, tested and stamped in accordance with ASME Code for refrigerant side working pressure of 300 psig. Water side working pressure is 300 psig for CGWE 20-50 and CCAD 20-60, 215 psig for CGWE 60. One water pass with a series of internal baffles. Each shell includes drain connections, entering and leaving temperature sensors, and  $\frac{3}{4}$  inch Armaflex II (or equal) insulation ( $K= 0.26$ ).

### Condenser (CGWE only)

Shell and tube design with seamless internally enhanced copper tubes. Designed and tested for refrigerant side working pressure of 450 psig. Water side working pressure is 300 psig for CGWE 20-50, 150 psig for CGWE 60. Two pass construction with six-inch diameter shell (20 to 30 tons). One pass construction with two separate condensers connected in series (40 to 60 tons). Each condenser includes a subcooler circuit. Tubes are cleanable and replaceable.

### Refrigerant Circuit

Each refrigeration circuit shall be completely independent and shall include liquid line and discharge line service valves, filter dryer, combination moisture indicator-sightglass, charging port, insulated suction line, liquid line solenoid valve and thermal expansion valve.

Isolation valves provide means of isolating refrigerant charge in either the high or low pressure side while servicing. One refrigerant circuit on 20 to 30 tons; two refrigerant circuits on 40 to 60 tons.

Condenserless units (CCAD) shall be equipped with discharge check valve and moisture indicator sightglass.

### Control Panel

Factory-mounted microprocessor based control panel uses 120/60/1 power. Automatic shutdown protection with manual reset is provided for low evaporator outlet refrigerant temperature and pressure, high condenser refrigerant pressure, motor current overload, and phase reversal. Automatic shutdown protection with automatic reset after condition is corrected is provided for low line voltage and loss of chilled water flow.

The unit control module (UCM) automatically takes action to prevent complete shutdown by shedding compressors one at a time. This occurs in the event of low evaporator refrigerant temperature, high condenser refrigerant pressure, motor current overload; preventing the motor current from exceeding setpoint.

Solid-state chilled water temperature sensors are included for precise and accurate control. A menu driven display indicates the operating code, the last diagnostic code, chilled water setpoint, current limit setpoint, condenser water and chilled water temperature sensors. Factory-installed entering and leaving condenser water temperature sensors (optional) are available for microprocessor display or Trane Tracer™ monitoring. Over 40 diagnostic checks are made and will be displayed when a problem is detected.

### Starter

The unit control panel contains both a control section and a starter section. The panel is a painted, NEMA 1 enclosure. The starter section contains: top access for power wiring, single point power hook-up, three-phase solid-state overload protection, customer wired grounding lug, and control power transformer with fused protection.



**Trane**  
**An American Standard Company**  
**[www.trane.com](http://www.trane.com)**

*For more information contact  
your local sales office or  
e-mail us at [comfort@trane.com](mailto:comfort@trane.com)*



Literature Order Number	CG-PRC011-EN
File Number	CG-PRC011-EN-0102
Supersedes	New
Stocking Location	La Crosse

*Since Trane has a policy of continuous product and product data improvement, it reserves the right to change design and specifications without notice.*



## Free Manuals Download Website

<http://myh66.com>

<http://usermanuals.us>

<http://www.somanuals.com>

<http://www.4manuals.cc>

<http://www.manual-lib.com>

<http://www.404manual.com>

<http://www.luxmanual.com>

<http://aubethermostatmanual.com>

Golf course search by state

<http://golfingnear.com>

Email search by domain

<http://emailbydomain.com>

Auto manuals search

<http://auto.somanuals.com>

TV manuals search

<http://tv.somanuals.com>