

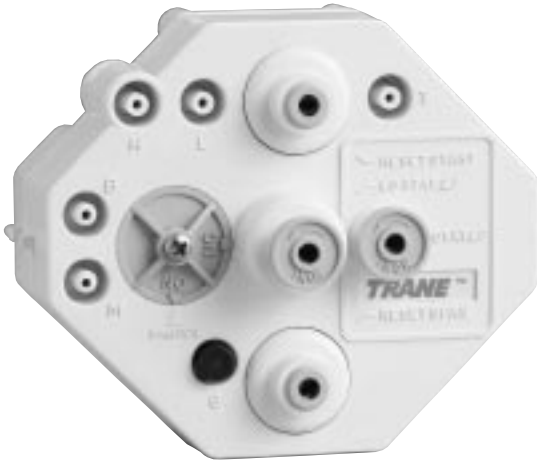

Installation/ Operation Maintenance

VariTrane™ Pneumatic Controls



March 2002

VAV-SVX02B-EN

Thermostat

Thermostat Selection and Location

In general, both one- and two-pipe thermostats have a gain of 2.5 psi per degree Fahrenheit, unless special thermostats are used that provide a different gain. The major difference between them is that a one-pipe thermostat is considered a low-capacity thermostat and a two-pipe thermostat is considered a high-capacity thermostat.

When selecting between one-pipe and two-pipe thermostats consider the following:

Use one-pipe thermostat when:

- tubing runs are less than 50 feet from thermostat to controller.
- a single thermostat will control no more than three controllers.
- slower response is desired from the thermostat.

Use two-pipe thermostat when:

- tubing runs exceed 50 feet from thermostat to controller.
- a single thermostat will control four or more controllers.
- high capacity air is required due to restrictions in the air line.

Thermostat Piping

The two-pipe thermostat (Figure 1) includes a restrictor (internally). Attach supply air line and output pressure (branch) line to the thermostat.

The one-pipe thermostat (Figure 2) requires an external restrictor tee. Connect main air supply to restricted leg of restrictor tee. Connect branch line from restrictor tee to the thermostat.

Figure 1—Two-Pipe Remote Thermostat (Reverse-Acting)

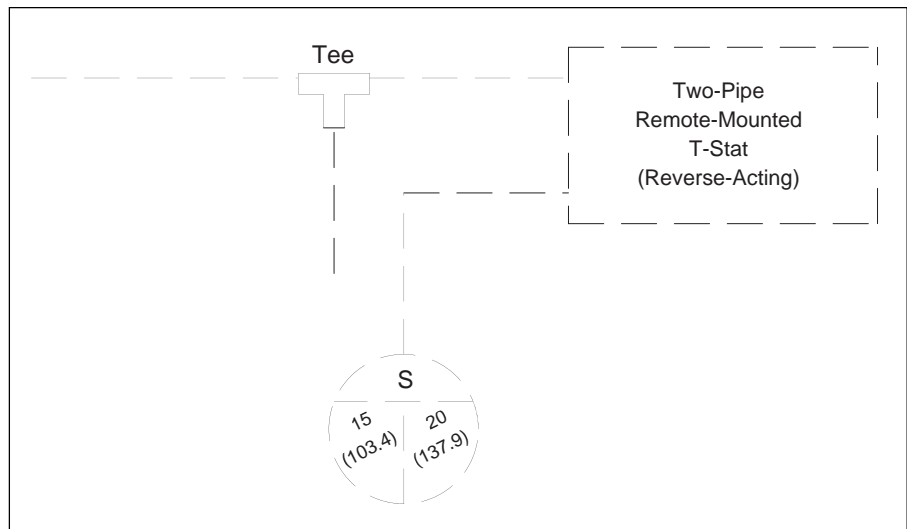
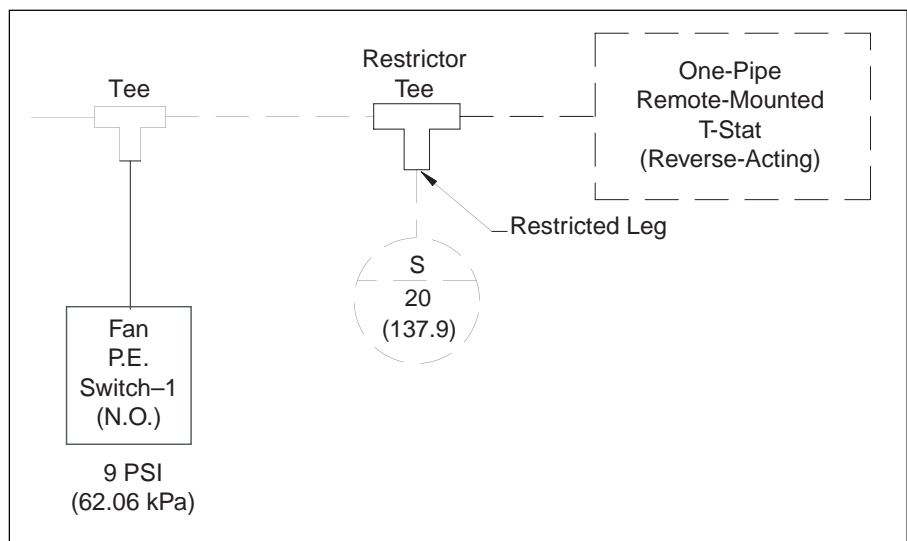

Figure 2—Typical One-Pipe Thermostat (Reverse-Acting)



Thermostat

Specifications

TP970 Series Pneumatic T-stats

Maximum Safe Air Pressure:
25psi (172 kPa)

Maximum Safe Air Temperature:
150°F (66°C)

Throttling Range:
2–10°F (1–5°C)

Gain:
2.5 psi/°F Adjustable

Operation

Pneumatic thermostats modulate output air pressure in response to room air temperature. Pneumatic thermostats fall into two categories: direct-acting or reverse-acting. This section describes how thermostat output pressure responds to changes in room temperature.

Figure 3 graphically illustrates the relationship between room temperature and output pressure of a direct-acting thermostat. The graph in Figure 3 shows that as the room temperature increases, so does the output pressure of the thermostat.

Figure 3—Direct-Acting Thermostat Response

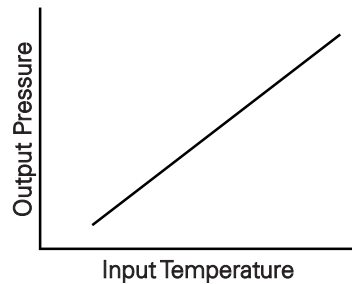
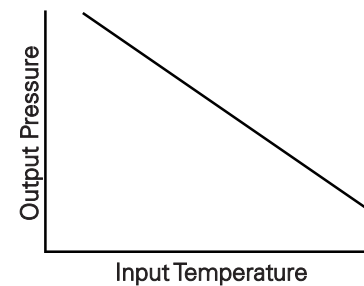

Figure 4 illustrates the pressure/temperature characteristics for a reverse-acting thermostat. As room temperature increases, the thermostat output pressure decreases.

Figure 4—Reverse-Acting Thermostat Response



A thermostat in proper working order will be able to output a pressure ranging from approximately .5 psi to supply air pressure depending on distance from indicated setpoint.

Reversing Relay

Installation and Operation

The reversing relay is a proportional, non-bleeding device for use in pneumatic control systems where a proportional signal from a controlling device must be reversed (see Figure 5). The most common use of the reversing relay is to change the action of a pneumatic thermostat.

Figure 5—Pneumatic Reversing Relay
Trane Part No. RLY-755

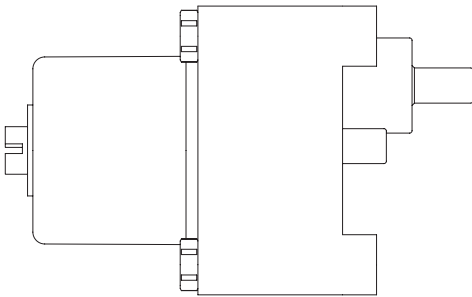

The reversing relay requires three piping connections: main/supply air, input signal air, and output branch air (see Figure 6). The branch line pressure decreases in direct proportion to an increase in the input signal pressure and vice-versa. The input signal is also amplified, thereby minimizing any pneumatic line transmission lag (see Figure 7).

Input pressure to the relay and output pressure to the PR should always add up to a constant, which is usually set between 16 and 25 psi. For example, with a constant of 18, six-pound input signal will result in a 12 pound branch signal. A bias adjustment screw is provided to retard or advance the out signal.

Figure 6—Reversing Relay Connections

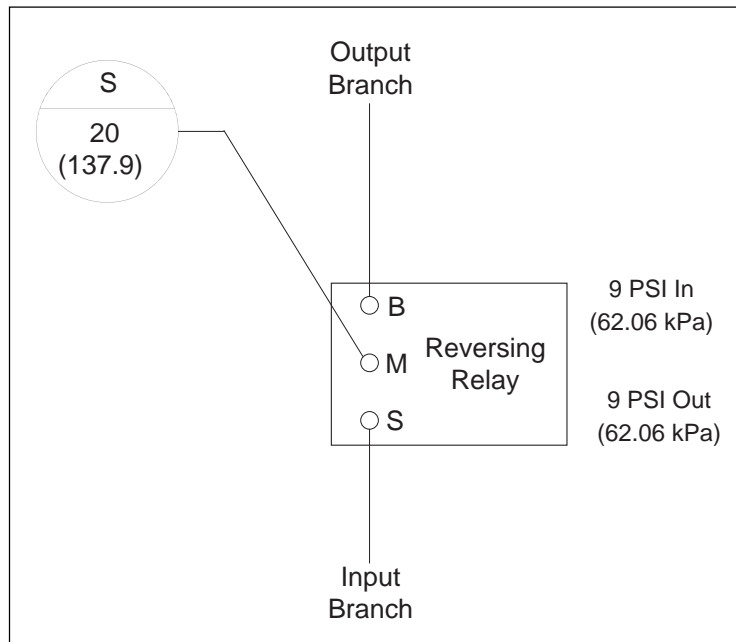
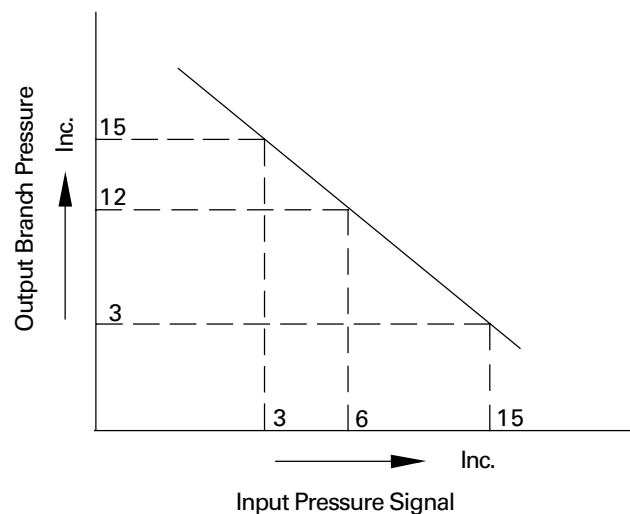

Figure 7—Reversing Relay Characteristics



Reversing Relay

Calibration

By using the "bias" adjustment on the relay, the factory-set 8.0–9.0 "cross-over" can be changed. To recalibrate, the relay should be connected as illustrated in Figure 8.

Figure 8—Recalibrating Reversing Relay

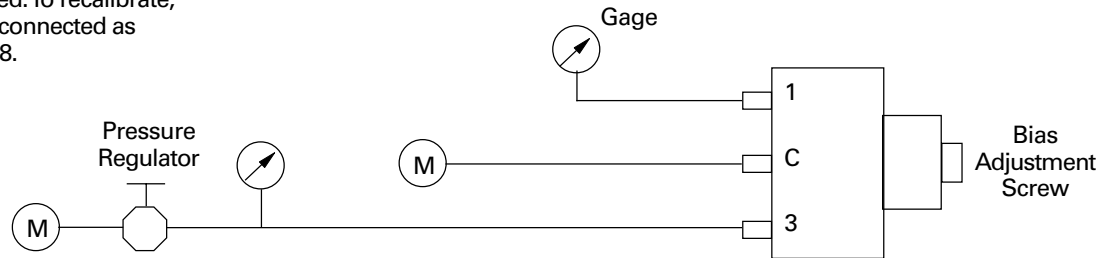

If the new desired "cross-over" pressure is 11.0 psi, this must be applied to port #3 by adjusting the pressure regulator. The "bias" adjustment is then turned until 11.0 psi is obtained on the output gage. Turning the "bias" adjustment "CW" increases the output; "CCW" decreases it.

This 11.0 psi "cross-over" would yield the following operational chart:

Chart

	1	2	3	4	5	6	7	8	9	10	11	12	13	14	15	16	17	18	19	20
Input:	1	2	3	4	5	6	7	8	9	10	11	12	13	14	15	16	17	18	19	20
Output:	20	19	18	17	16	15	14	13	12	11	10	9	8	7	6	5	4	3	2	1

New Cross-over pressure

Specifications

Maximum Pressure:

30 psig

Connections:

3/16" (4.8 mm) nipples for 1/4" (6.4 mm) OD polyethylene tubing

Air Consumption:

0.5 SCFH (.236 L/M) @ 20 psig

Material:

ABS

Weight:

3 1/2 oz

Ambient Limits:

+40°F/+120°F operating (+4°C/+49°C)

Mounting:

In-line via air connections

Factory Settings:

9 psig in./9 psig out and 8 psig in./8 psig out

Bias Adjustment:

+/-15 psi

Model 3011 – Pneumatic Volume Regulator

Model 3011

The model 3011 Pneumatic Volume Regulator (PVR) is capable of operating with normally-open or normally-closed air valves and can operate with either direct-acting (DA) or reverse-acting (RA) thermostats.



Installation

1. Attach bracket either vertically or horizontally to the illustration surface. Horizontal is preferred, vertical is acceptable, any other position is not acceptable (see Figure 9).
2. Insert controller into its bracket. Controller may be face up, face down, face left, or face right. The controller LO and HI stat delta P must be calibrated in the same position that it is mounted.

Figure 9–Acceptable Installation Positions

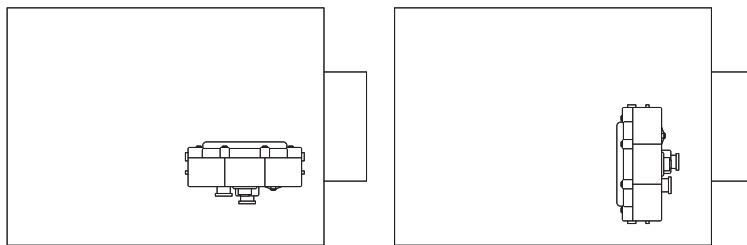

Connections

Figure 10 illustrates a typical piping diagram of a normally-open or normally-closed unit.

Figure 10–Typical Piping Diagram of Normally-Open or Normally-Closed Unit

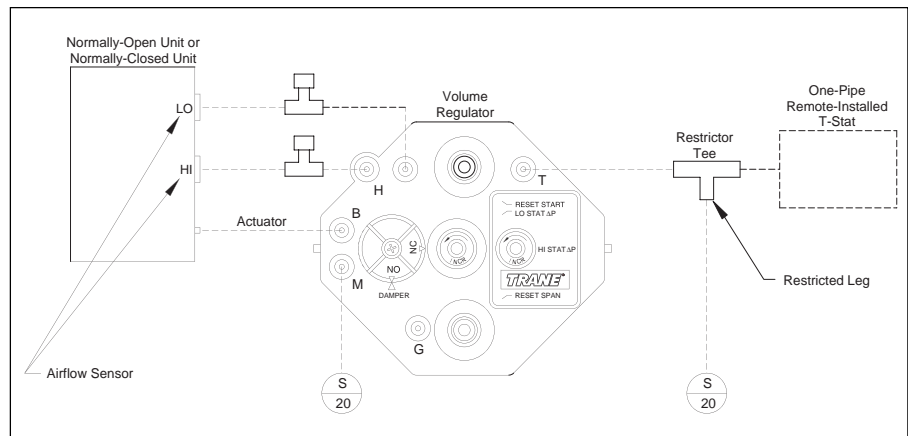

Selecting Direct- or Reverse-Acting Thermostat (3011)

The model 3011 PVR must be calibrated to operate with either a direct-acting or reverse-acting thermostat. The control must also be changed when used with a normally-open or normally-closed air valve.

Model 3011 – Pneumatic Volume Regulator

Use the following procedure to set-up the PVR:

1. Select damper action (NO or NC). Loosen damper selection switch screw and align to either the NO or NC pointer with damper pointer and tighten screw.
2. Now determine the type of thermostat that will be used. If a direct-acting thermostat is used, the reset start pressure is typically 8 psi. If a reverse-acting thermostat is used, the reset start pressure is typically 3 psi (see Figure 11).
3. With an accurate gage (0-10 psi) connected to port "G", regulate the thermostat pressure to port "T" to desired start point pressure.
4. Adjust reset start to indicate 0 psi on port "G" and continuing adjusting to indicate a pressure slightly higher than 0 psi, (i.e., 0.1 psi).

Figure 11–Adjusting Reset Start

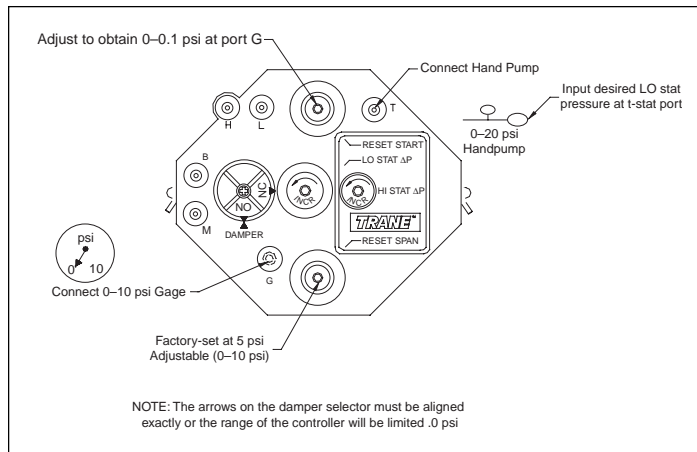

Adjusting the Reset Span (3011)

The reset span is factory-set at 5 psi. This is the thermostat pressure difference from which the PVR delivers flow from minimum to maximum setpoints. This range is not normally changed unless a special control scheme is used where control operation must be changed.

To field adjust a different reset span, follow these steps:

1. Connect an accurate gage to port "G".
2. Apply 20 psi to port "T".
3. Adjust reset span to indicate the desired span on port "G" (see Figure 12).
4. LO-stat and HI-stat delta P must now be readjusted (see following calibration procedure)

Figure 12–Adjusting Reset Span

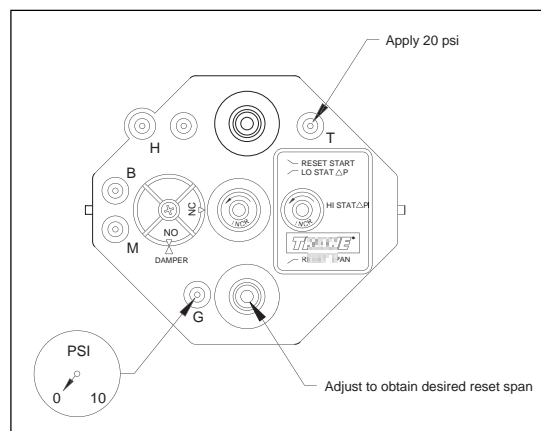

Calibration Procedures

Calibration Procedure (Steps 1–4 apply to all thermostat models)

1. Be sure the PVR is installed correctly and that all connections are hooked up to the proper ports. See Figure 9 for unit application.
2. Remove the caps on the tees which are connected to the lines to the flow sensor. Connect a 0–2" magnehelic gage to monitor flow sensor delta P. The higher-pressure port is further upstream on the air valve inlet.
3. Remove the thermostat line and connect a hand pump with a 0–20 psi gage to port "T".
4. Tee a 0–20 psi gage in the line from port "B" on the volume regulator to the air valve actuator.

Normally-Open Valve

Normally-Open Valve

Direct-Acting Thermostat
(See Figure 13 for proper connections)

Reverse-Acting Thermostat
(See Figure 13 for proper connections):

Direct-Acting Thermostat
(See Figure 14 for proper connections):

Reverse-Acting Thermostat
(See Figure 14 for proper connections):

5. Set port "T" at 0 psi.
6. Monitor the delta P and adjust the LO-stat (minimum) adjustment to desired minimum.
7. Set port "T" input at 16 psi or greater with the hand pump.
8. Monitor the delta P and adjust the HI-stat (maximum) adjustment to desired maximum flow. If the actuator pressure is less than 3 psi, the air valve is wide open and duct pressure must increase to increase flow.
9. Set port "T" at 0 psi.
10. Monitor the minimum flow delta P. If it is not correct, adjust the LO-stat adjustment knob.

5. Set port "T" at 0 psi.
6. Monitor the delta P and adjust the LO-stat delta P (maximum) adjustment to desired maximum. If the actuator pressure is less than 3 psi, the air valve is wide open and duct pressure must increase to increase flow.
7. Set port "T" to 16 psi or greater with the hand pump.
8. Monitor the delta P and adjust the HI-stat (minimum) adjustment to desired minimum flow.
9. Set port "T" at 0 psi.
10. Monitor the maximum flow delta P. If it is not correct, adjust the LO-stat adjustment knob.

5. Set port "T" at 0 psi.
6. Monitor the delta P and adjust the LO-stat (minimum) adjustment to desired minimum.
7. Set port "T" input at 16 psi or greater with the hand pump.
8. Monitor the delta P and adjust the HI-stat (maximum) adjustment to desired maximum flow. If the actuator pressure is greater than 13 psi, the air valve is wide open and duct pressure must increase to increase flow.
9. Set port "T" at 0 psi.
10. Monitor the minimum flow delta P. If it is not correct, adjust the LO-stat adjustment knob.

5. Set port "T" at 0 psi.
6. Monitor the delta P and adjust the LO-stat delta P (maximum) adjustment to desired maximum flow. If the actuator pressure is greater than 13 psi, the air valve is wide open and duct pressure must increase to increase flow.
7. Set port "T" to 16 psi or greater with the hand pump.
8. Monitor the delta P and adjust the HI-stat (minimum) adjustment to desired minimum flow.
9. Set port "T" at 0 psi.
10. Monitor the maximum flow delta P. If it is not correct, adjust the LO-stat adjustment knob.

Figure 13–Connections of Direct/Reverse-Acting Thermostat with Normally-Open Valve

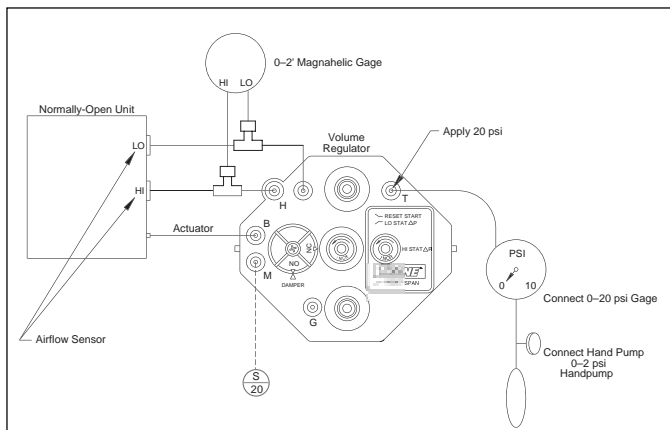
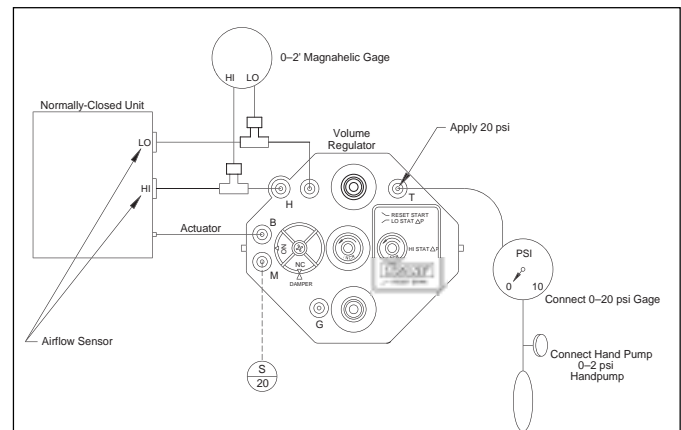

Figure 14–Connections of Direct/Reverse-Acting Thermostat with Normally-Closed Valve



Specifications (3011)

Specifications (3011)

Differential Pressure Range:

0 to 1.0 in. wg

Minimum Setpoint Range:

0 to 1.0" H₂O

Maximum Setpoint Range:

minimum to 1.0 in. wg

Operating Static Range:

0.25–6.0 in. wg

Normal Supply Air Pressure:

20.0 psi

Minimum Supply air Pressure:

15.0 psi

Maximum Supply Air Pressure:

30.0 psi

Average Supply Air Consumption:

28.8 scim at 20 psi

Thermostat Pressure Input Range:

Adjustable 0–10 psi band from 0–20 psi

Reset Start Point Range:

0–10 psi

Reset Span Range:

0–10 psi

Maximum Safe Thermostat Input:

30 psi (closed chamber)

Operating Temperature:

+40/+120°F

Storage Temperature:

-40/+140°F

Main, Thermostat, Actuator and Static

Pick-up Connections:

.250 O.D.



Model 3501 – Pneumatic Volume Regulator

Model 3501

The model 3501 Pneumatic Volume Regulator (PVR) is capable of operating with normally-open or normally-closed air valves and can operate with either direct-acting (DA) or reverse-acting (RA) thermostats.



Installation

1. Attach bracket either vertically or horizontally to the installation surface. Horizontal is preferred, vertical is acceptable, any other position is not acceptable.
2. Insert controller into its bracket. Controller may be face up, face down, face left, or face right. The controller LO and HI stat delta P must be calibrated in the same position that it is installed.

Selecting Direct- or Reverse-Acting Thermostat (3501)

The model 3501 PVR must be calibrated to operate with either a direct-acting or reverse-acting thermostat. The control must also be changed when used with a normally-open or normally-closed air valve.

Use the following procedure to set-up the PVR:

1. Select damper action (NO or NC). Loosen damper selection switch screw and align to either the NO or NC pointer with damper pointer and tighten screw.
2. Now determine the type of thermostat that will be used. If a direct-acting thermostat is used, the reset start pressure is typically 8 psi. If a reverse-acting thermostat is used, the reset start pressure is typically 3 psi.
3. With an accurate gage (0–30 psi) connected to port “G”, regulate the thermostat pressure to port “T” to 10.5 psi.
4. Adjust reset start to indicate 2.5 psi on port “G”

Adjusting the Reset Span (3501)

The reset span is factory-set at 5 psi. This is the thermostat pressure difference from which the PVR delivers flow from minimum to maximum setpoints. This range is not normally changed unless a special control scheme is used where control operation must be changed.

To field adjust a different reset span, follow these steps:

1. Connect an accurate gage to port “G”.
2. Apply 20 psi to port “T”.
3. Adjust reset span to indicate the desired span on port “G”.
4. LO-stat and HI-stat delta P must now be readjusted (see following calibration procedure).

Calibration Procedures

Calibration Procedure (Steps 1–4 apply to all thermostat models)

1. Be sure the PVR is installed correctly and that all connections are hooked up to the proper ports.
2. Remove the caps on the tees, which are connected to the lines to the flow sensor. Connect a 0–2" magnehelic gage to monitor flow sensor delta P. The higher-pressure port is further upstream on the air valve inlet.
3. Remove the thermostat line and connect a hand pump with a 0–20 psi gage to port "T"
4. Tee a 0–20 psi gage in the line from port "B" on the volume regulator to the air valve actuator.

Normally-Open Valve

- | Direct-Acting Thermostat | Reverse-Acting Thermostat |
|---|--|
| 5. Set port "T" at 0 psi. | 5. Set port "T" at 0 psi. |
| 6. Monitor the delta P and adjust the LO-stat (minimum) adjustment to desired minimum. | 6. Monitor the delta P and adjust the LO-stat delta P (maximum) adjustment to desired maximum. If the actuator pressure is less than 3 psi, the air valve is wide open and duct pressure must increase to increase flow. |
| 7. Set port "T" input at 16 psi or greater with the hand pump. | 7. Set port "T" to 16 psi or greater with the hand pump. |
| 8. Monitor the delta P and adjust the HI-stat (maximum) adjustment to desired maximum flow. If the actuator pressure is less than 3 psi, the air valve is wide open and duct pressure must increase to increase flow. | 8. Monitor the delta P and adjust the HI-stat (minimum) adjustment to desired minimum flow. |
| 9. Set port "T" at 0 psi. | 9. Set port "T" at 0 psi. |
| 10. Monitor the minimum flow delta P. If it is not correct, adjust the LO-stat adjustment knob. | 10. Monitor the maximum flow delta P. If it is not correct, adjust the LO-stat adjustment knob. |

Normally-Closed

- | Direct-Acting Thermostat | Reverse-Acting Thermostat |
|---|--|
| 5. Set port "T" at 0 psi. | 5. Set port "T" at 0 psi. |
| 6. Monitor the delta P and adjust the LO-stat (minimum) adjustment to desired minimum. | 6. Monitor the delta P and adjust the LO-stat delta P (maximum) adjustment to desired maximum. If the actuator pressure is greater than 13 psi, the air valve is wide open and duct pressure must increase to increase flow. |
| 7. Set port "T" input at 16 psi or greater with the hand pump. | 7. Set port "T" to 16 psi or greater with the hand pump. |
| 8. Monitor the delta P and adjust the HI-stat (maximum) adjustment to desired maximum flow. If the actuator pressure is greater than 13 psi, the air valve is wide open and duct pressure must increase to increase flow. | 8. Monitor the delta P and adjust the HI-stat (minimum) adjustment to desired minimum flow. |
| 9. Set port "T" at 0 psi. | 9. Set port "T" at 0 psi. |
| 10. Monitor the minimum flow delta P. If it is not correct, adjust the LO-stat adjustment knob. | 10. Monitor the maximum flow delta P. If it is not correct, adjust the LO-stat adjustment knob. |



Specifications (3501)

Specifications (3501)

Differential Pressure Range:

0 to 1.0 in. wg

Minimum Setpoint Range:

0 to 1.0" H₂O

Maximum Setpoint Range:

minimum to 1.0 in. wg

Maximum Setpoint Range:

6.0 in. wg

Normal Supply Air Pressure:

20.0 psi

Minimum Supply air Pressure:

15.0 psi

Maximum Supply Air Pressure:

30.0 psi

Output Sensitivity:

5 psi/.02

Average Supply Air Consumption:

43.2 scim at 20 psi

Reset Start Point Range:

0–10 psi

Reset Span Range:

0–7 psi

Operating Temperature:

+40/+120°F

Storage Temperature:

-40/+140°F

MCP-3631 – Rotary Pneumatic Damper Actuator

MCP-3631 – Rotary Pneumatic Damper Actuator

Description:

Rotary actuators mounts to a standard ½" diameter shaft by a locking collar and bushing.

Models:

MCP-3631-5000 8–13 psi range
(55–90 kPa) Normally-Closed operation

MCP-3631-8000 3–8 psi range
(21–55 kPa) Normally-Open operation



Installation Method:

Slide collar onto shaft. Slide actuator onto shaft noting directional rotation. Slide bushing onto shaft into actuator, aligns actuator with damper, lock collar and bushing set screws, and install bracket.

Maintenance:

No routine maintenance is required.

Specifications:

Effective Area:

8 sq in. (52 sq cm)

Normal Rotation:

100 deg

Supply Pressure:

0 to 20 psig (138 kPa) operating
30 psig (207 kPa) max

Spring Ranges:

Retracted/extended Torque
(Based on 0 & 20 psi applied)

8–13 psi (55–90 kPa);
68/59 in. lbs (8/7 Nm) @ 90 deg

3–8 psi (21–55 kPa);
25/102 in. lbs (3/12 Nm) @ 90 deg

Supply Connection:

3/16" (5 mm) nipple for ¼" (6 mm)
OD polyethylene tubing

Material:

Body Glass-filled nylon
Diaphragm Neoprene

Weight:

1.5 lbs (0.68 kg)

Ambient Limits:

Operating -20°F–120°F (-29°C–49°C)
Shipping -40°F–140°F (-40°C–60°C)

Constant-Volume Dual-Duct Calibration (3011)

Constant Volume Dual-Duct Calibration (3011)

This calibration procedure is used when a constant volume of air must be maintained through a unit. On a dual-duct unit, a constant-volume discharge sensor is used to measure the air leaving the unit. The PVR controlling to a constant-volume of air leaving the unit uses the discharge sensor to maintain the specified cfm.

This PVR does not require a thermostat connected to the PVR.

The following procedure must be used when calibrating a constant-volume dual-duct unit. See Figure 15 for a typical piping diagram.

1. Set t-stat to full heat.
2. Set LO thermostat (maximum) to the desired maximum flow on the heating deck.
3. Set t-stat to full cool.
4. Set HI thermostat (minimum) to the desired minimum flow on the heating deck.
5. Set LO thermostat adjustment knob on cooling deck (CV deck) to desired constant-volume.
6. Exercise the system to check flows for proper operation.

Figure 15—Typical Constant-Volume Dual-Duct Piping Diagram

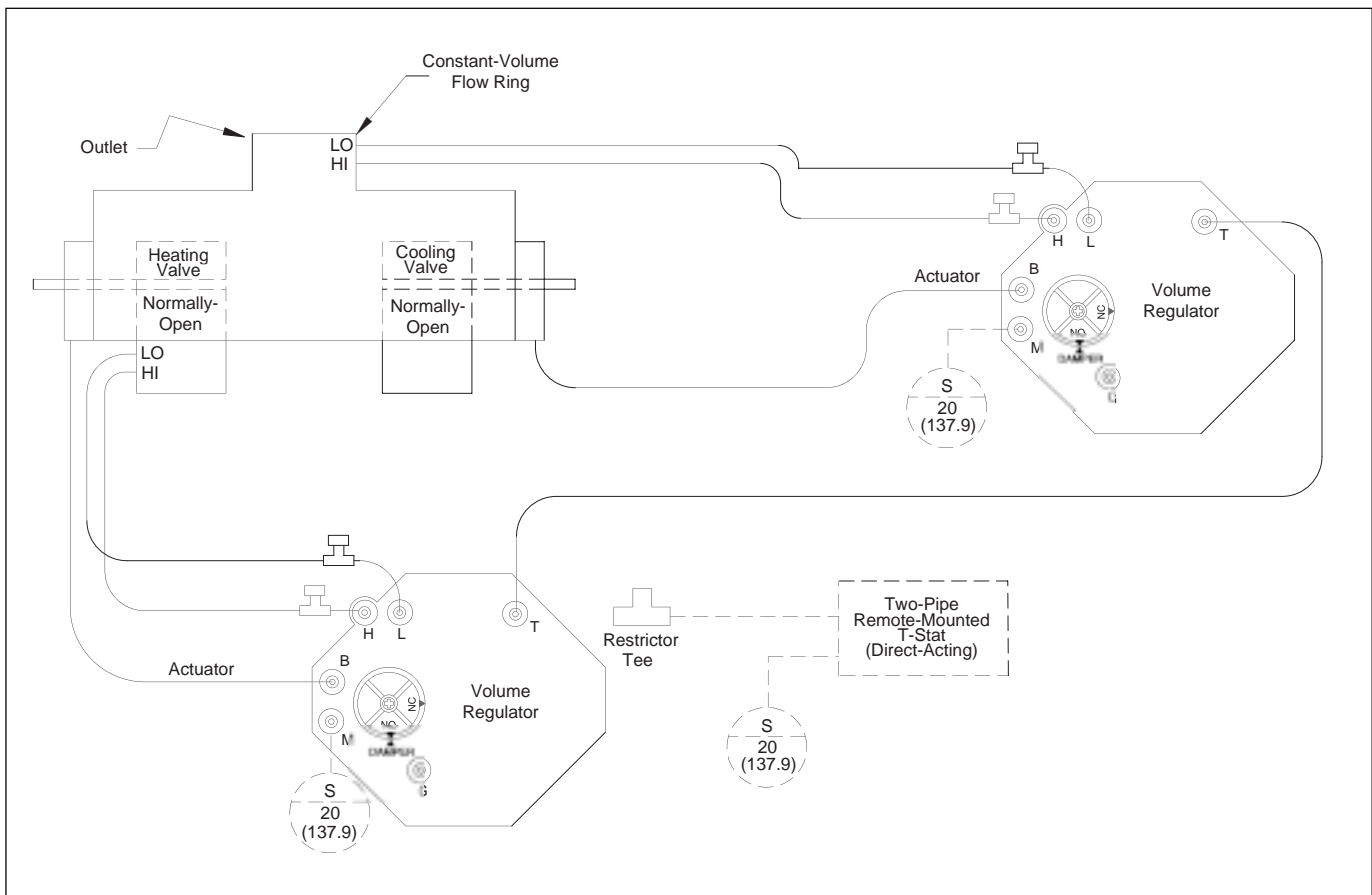

Variable Air Volume Dual-Duct Calibration (3011)

Variable-Air-Volume Dual-Duct Calibration (3011)

Figure 16 is a typical piping diagram of a VAV dual-duct unit. The unit has a thermostat piped to both pneumatic volume regulators (PVR) which will operate the heating deck from a thermostat signal of 3–8 psi. The cooling deck will operate from a thermostat signal of 8–13 psi. With normal calibration of the PVR, the unit will have both the heating and cooling deck at minimum with a thermostat signal of 8 psi.

In order to have a unit minimum cfm and still have 0 cfm minimums on both the heating and cooling deck, special calibration is required. The PVR has a “reset start” adjustment knob, which allows the unit to be calibrated to a minimum cfm. This is achieved by crossing over the thermostat ranges. Figure 17 illustrates this concept.

Figure 16—Typical VAV Dual-Duct Piping Diagram

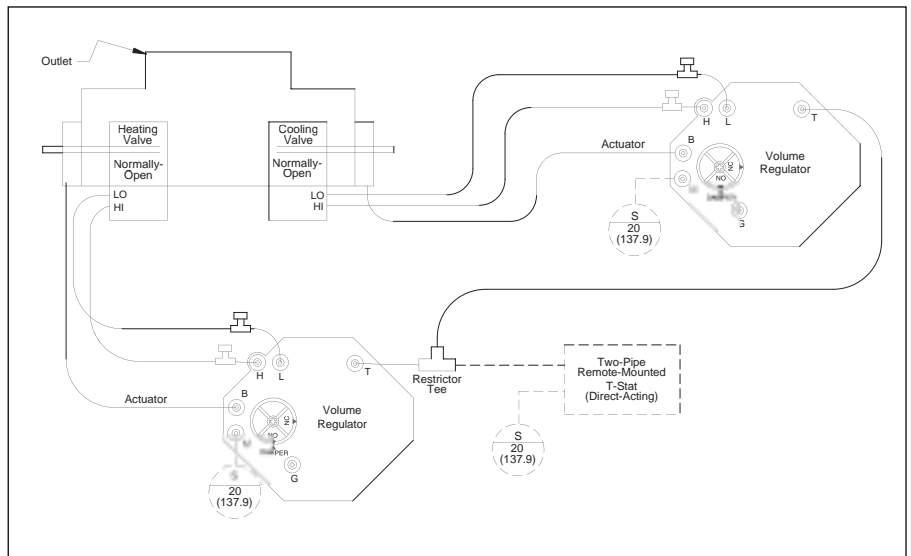
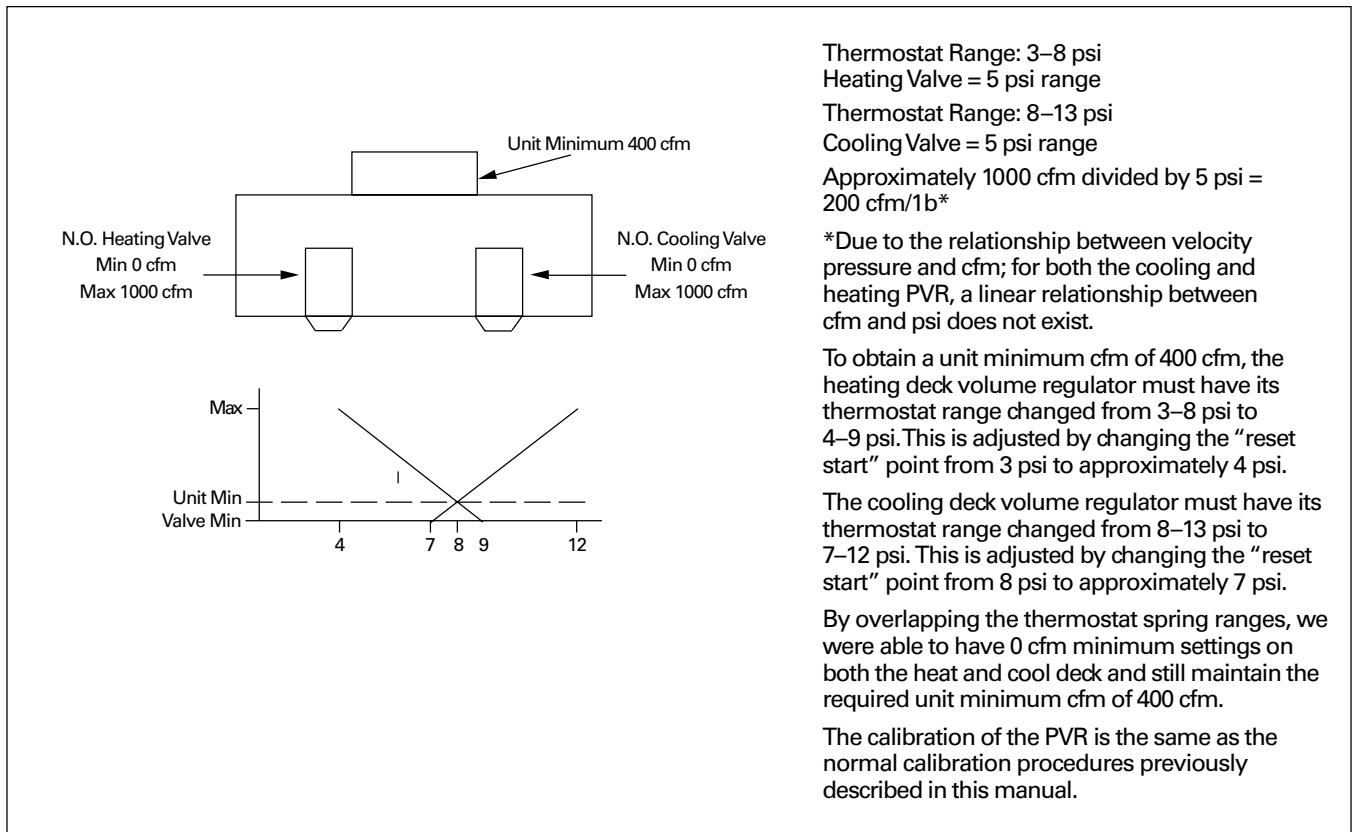

Figure 17—Example



Constant-Volume Single-Duct VAV (VCV 3011)

Constant-Volume Single-Duct VAV (VCV 3011)

This is used when a constant volume of air is required to supply a zone. A thermostat is still often required to modulate a reheat coil to maintain temperature control. The thermostat is never connected to the "T" port on the volume regulator. The following procedure is used to calibrate this type of unit with a PVR.

1. Be sure there is 0 psi at the "T" port.
2. Set LO thermostat adjustment knob to desired unit cfm.

The unit will now modulate to the calibrated cfm setting. See Figure 18 for typical constant volume single-duct piping diagram.

Figure 18—Typical Constant-Volume Single-Duct Piping Diagram

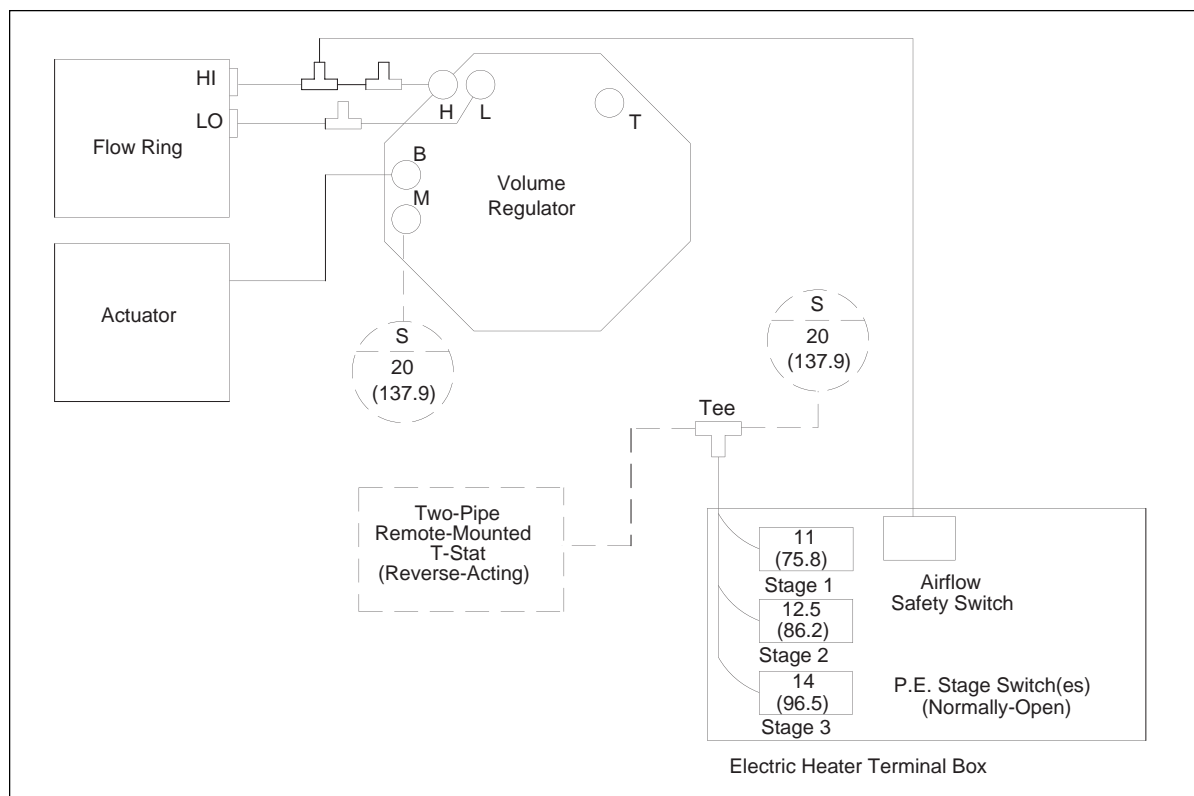

TRANE

Trane
An American Standard Company
www.trane.com

For more information contact
your local district office or
e-mail us at comfort@trane.com

Literature Order Number	VAV-SVX02B-EN
File Number	SV-TD-VAV000-SVX02B-EN-0302
Supersedes	VAV-SVX02A-EN & VAV-IOM-6
Stocking Location	La Crosse

Trane has a policy of continuous product and product data improvement and reserves the right to change design and specifications without notice. Only qualified technicians should perform installation and servicing of equipment referred to in this publication.

Free Manuals Download Website

<http://myh66.com>

<http://usermanuals.us>

<http://www.somanuals.com>

<http://www.4manuals.cc>

<http://www.manual-lib.com>

<http://www.404manual.com>

<http://www.luxmanual.com>

<http://aubethermostatmanual.com>

Golf course search by state

<http://golfingnear.com>

Email search by domain

<http://emailbydomain.com>

Auto manuals search

<http://auto.somanuals.com>

TV manuals search

<http://tv.somanuals.com>