

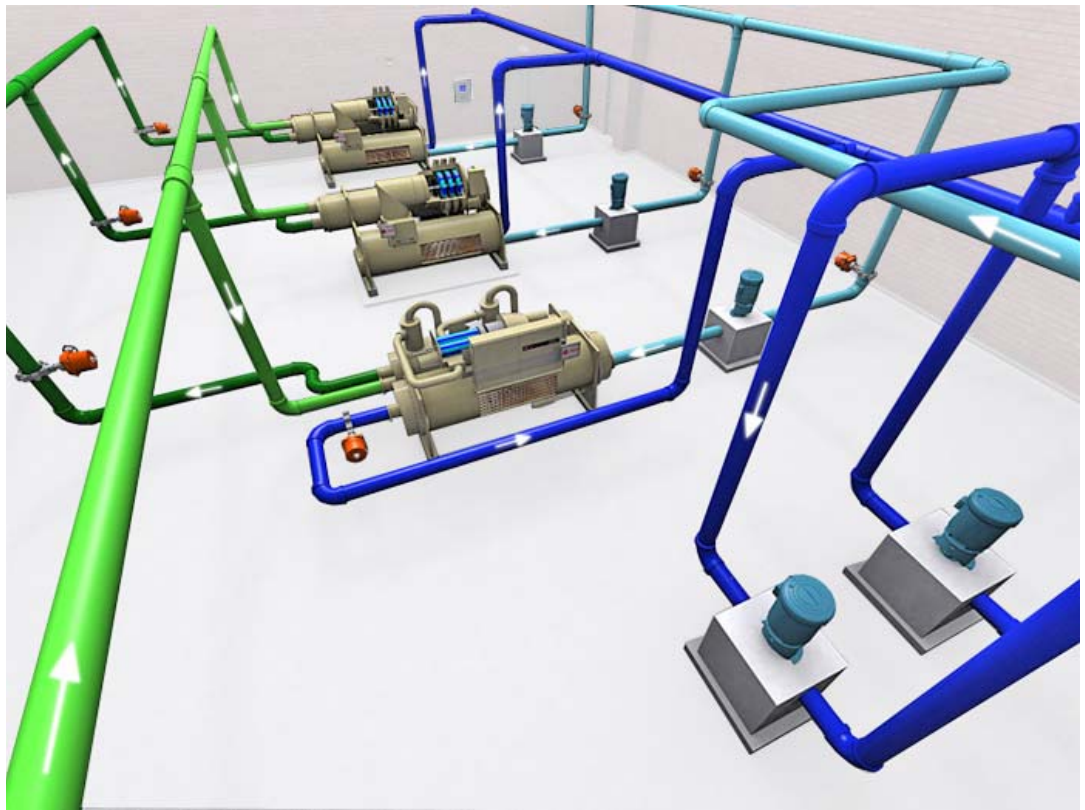

TRANE®

Applications Engineering Manual

Chiller System Design and Control



May 2009

SYS-APM001-EN



Chiller System Design and Control

Susanna Hanson, applications engineer
Mick Schwedler, applications manager
Beth Bakkum, information designer



Preface

This manual examines chilled-water-system components, configurations, options, and control strategies. The goal is to provide system designers with options they can use to satisfy the building owners' desires, but this manual is not intended to be a complete chiller-system design manual.

System designers may get the most use from this manual by familiarizing themselves with chilled-water-system basics and understanding the benefits of various options. Thereafter, when a specific job will benefit from these advantages, consult appropriate sections of the manual in detail.

The *Engineers Newsletters* that are referenced in this manual are available at: www.trane.com/commercial/library/newsletters.asp

Trane, in proposing these system design and application concepts, assumes no responsibility for the performance or desirability of any resulting system design. Design of the HVAC system is the prerogative and responsibility of the engineering professional.

"Trane" and the Trane logo are registered trademarks, and TRACE, System Analyzer and TAP are trademarks of Trane, a business of Ingersoll-Rand.

Contents

Preface	i
Primary System Components	1
Chiller	1
Loads	7
Chilled-Water Distribution System	10
Condenser-Water System	13
Unit-Level Controls	15
Application Considerations	18
Small Chilled-Water Systems (1-2 chillers)	18
Mid-Sized Chilled-Water Systems (3-5 Chillers)	21
Large Chilled-Water Systems (6+ Chillers, District Cooling)	22
Chiller Plant System Performance	24
System Design Options	27
Condenser-Water Temperatures	29
Chilled- and Condenser-Water Flow Rates	29
Cost Implications	38
Misconceptions about Low-Flow Rates	39
System Configurations	42
Parallel Chillers	42
Series Chillers	44
Primary–Secondary (Decoupled) Systems	45
Variable-Primary-Flow Systems	55
Chilled-Water System Variations	70
Heat Recovery	70
Condenser “Free Cooling” or Water Economizer	70
Preferential Loading	73
Series–Counterflow Application	77
Unequal Chiller Sizing	78
System Issues and Challenges	79
Low ΔT Syndrome	79
Amount of Fluid in the Loop	79
Contingency	81
Alternative Energy Sources	82
Plant Expansion	83
Retrofit Opportunities	84
Applications Outside the Chiller’s Range	84

System Controls	87
Chilled-Water System Control	87
Condenser-Water System Control	89
Failure Recovery	95
Conclusion	96
Glossary	97
References	100
Index	103

Primary System Components

Chilled-water systems consist of these functional parts:

- Chillers that cool the water or fluid
- Loads, often satisfied by coils, that transfer heat from air to water
- Chilled-water distribution pumps and pipes that send chilled water to the loads
- Condenser-water pumps, pipes, and cooling towers or condenser fans that reject heat from the chiller to ambient air
- Controls that coordinate the operation of the mechanical components together as a system

For more details on the basic operation and components of a chilled-water system, consult another Trane publication, *Chilled-Water Systems*, part of the Air Conditioning Clinic Systems Series (TRG-TRC016-EN).

In most cases, the chiller's purpose is to make water colder. Some chillers cool a mixture of water and other chemicals, most commonly added to prevent freezing in low-temperature applications. Other additives may be used to modify the properties of the fluid, thereby making it more suitable for its intended application. For the purposes of this manual, the term water can be understood to be any such acceptable fluid, with recognition of the diverse applications in which chillers are used.

The chiller rejects the heat extracted from the chilled water, plus the heat of compression (in the vapor-compression cycle), or the heat of absorption (in the case of an absorption chiller) to either the ambient air (air-cooled) or to another circuit of water (water-cooled). If the compressor-motor is refrigerant cooled, the chiller also rejects heat generated by motor inefficiency. Air-cooled condensers use fans to facilitate cooling by the ambient air. Water-cooled condensers typically use an evaporative cooling tower.

After the water has been chilled, it is distributed via pumps, pipes, and valves (the distribution system) to the loads, where a heat exchanger—for example, a cooling coil in an air-handler—transfers heat from the air to the chilled water, which is returned to the chiller.

Each component of the chilled-water system is explained in more detail in the following sections.

Chiller

Specific application considerations for absorption chillers are addressed in another Trane publication, *Absorption Chiller System Design* (SYS-AM-13).

There are a variety of water chiller types. Most commonly, they are absorption, centrifugal, helical rotary, and scroll. Some reciprocating chillers are also available. Chillers can be either air- or water-cooled. Major vapor-compression chiller components include an evaporator, compressor(s), condenser, and expansion device(s) (Figure 1). This manual discusses the chiller's evaporator and condenser and their relationship to the chilled-water system.

Figure 1. Typical vapor-compression chiller

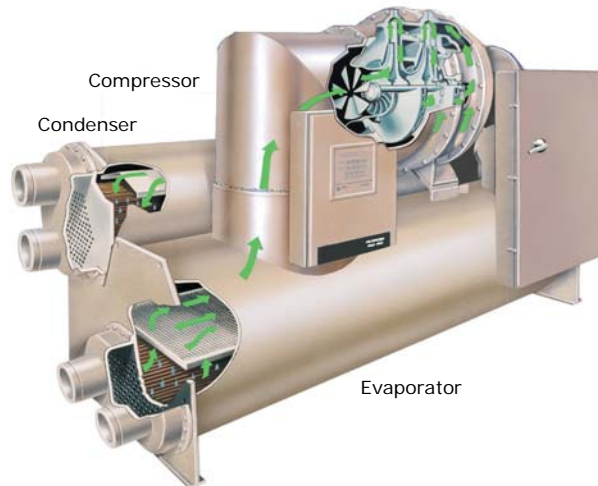

Water-cooled chillers are typically installed indoors; air-cooled chillers are typically installed outdoors—either on the roof or next to the building. In cold climates, air-cooled chillers may have a remote evaporator inside the building for freeze protection.

Chiller evaporator

The evaporator section of a water chiller is a shell-and-tube, refrigerant-to-water heat exchanger. Depending on the chiller's design, either the refrigerant or the water is contained within the tubes.

- In a flooded shell-and-tube evaporator (Figure 2), cool, liquid refrigerant at low pressure enters the distribution system inside the shell and moves uniformly over the tubes, absorbing heat from warmer water that flows through the tubes.

Figure 2. Flooded evaporator cut-away

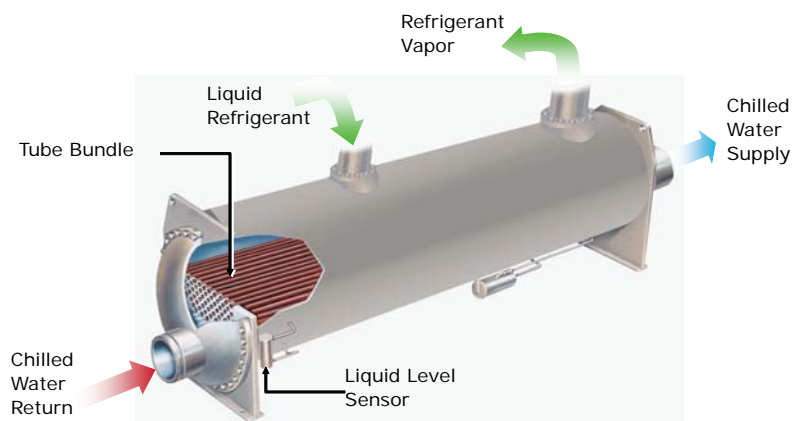

- In a direct-expansion (DX) shell-and-tube evaporator (Figure 3), warmer water fills the shell while the cool, lower-pressure liquid refrigerant flows through the tubes.

Figure 3. Direct-expansion evaporator cut-away

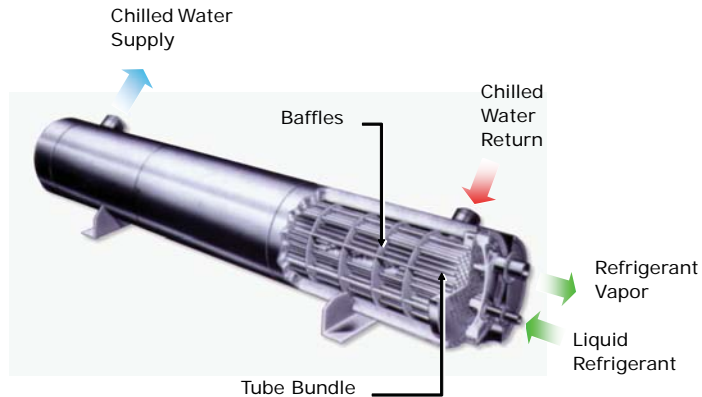

In either design, there is an approach temperature, which is the temperature difference between the refrigerant and exit water stream temperatures. The approach temperature is a measure of the heat transfer efficiency of the evaporator.

Effect of chilled-water temperature

For a given chiller, as the leaving chilled-water temperature drops, the refrigerant temperature and pressure must also drop. Conversely, as the leaving chilled-water temperature rises, so do the refrigerant temperature and pressure. When the leaving chilled-water temperature changes, the work a compressor must do also changes. The effect of leaving chilled-water temperature change on power consumption can be 1.0 to 2.2 percent per degree Fahrenheit [1.8 to 4.0 percent per degree Celsius]. Always consider the energy consumption of the entire system—not only the chiller. It is important to remember that although reducing leaving chilled-water temperature penalizes the chiller, it may reduce the overall system energy because less water is pumped through the system. System interactions are covered in more detail in “System Design Options” on page 27.

Effect of chilled-water flow rate and variation

The evaporator is sensitive to the water flow rate. Excessive flow may result in high water velocity, erosion, vibration, or noise. Insufficient flow reduces heat-transfer efficiency and causes poor chiller performance, which might cause the chiller controls to invoke safeties. Some designers have concerns over low flow rates causing fouling. Generally, as Webb and Li¹ noted, these concerns are unwarranted since the chilled-water loop is a closed system, thus reducing the chances of materials entering the system and causing fouling. Chilled-water flow through the evaporator must be kept within specific minimum and maximum limits. Contact the manufacturer for these limits.

Some chiller controls can accommodate very little flow variation during machine operation.² Other, more sophisticated, chiller controls allow some flow variation. Some chillers can tolerate flow-rate variations—as much as 50 percent per minute or greater—while others can only tolerate up to 2 percent per minute. It is important that chiller capabilities are matched to system requirements. Contact the chiller manufacturer to determine the allowable rate of flow variation before varying the flow through the evaporator in a chiller. Flow variation is discussed in detail in the section “Variable-Primary-Flow Systems” on page 55.

Water-cooled condenser

To cool a building or process, the transferred heat must ultimately be rejected outdoors or to another system (heat recovery). The total amount of heat rejected includes the sum of the evaporator load, the compressor work, and the motor inefficiency. In a hermetic chiller, where the motor and compressor are in the same housing, these loads are all rejected through the condenser. In an open chiller, where the motor is separate from the compressor and connected by a shaft, the motor heat is rejected directly to the surrounding air. The evaporator load and the compressor work are rejected through the condenser, and the motor heat must be taken care of by the equipment room’s air-conditioning system.

Effect of condenser-water temperature

For a given chiller, as the leaving condenser-water temperature rises, refrigerant temperature and pressure also rise. Conversely, as the leaving condenser-water temperature drops, so do refrigerant temperature and pressure. As the refrigerant pressure and temperature changes, the work a compressor must do also changes. The effect of leaving-condenser-water temperature change on power consumption can be 1.0 to 2.2 percent per degree Fahrenheit [1.8 to 4.0 percent per degree Celsius]. Always consider the energy consumption of the entire system—not just the chiller. It is important to remember that although raising the leaving condenser-water temperature penalizes the chiller energy, it may reduce the energy used by the condenser pumps and cooling tower through the use of reduced flow rates and higher thermal driving-forces on the tower. System interactions are covered in more detail in “System Design Options” beginning on page 27.

Effect of condenser-water flow rate

The condenser is sensitive to the water flow rate. Excessive flow may result in high water velocity, erosion, vibration, or noise, while insufficient flow reduces heat transfer efficiency and causes poor chiller performance. Therefore, condenser-water flow through the chiller should be kept within a specific range of limits, except during transient startup conditions. Contact the manufacturer for these limits. Some chillers may allow extended operation below the selected flow rates.

If water velocity through the condenser tubes is too low for significant periods of time and the water is extremely hard, long-term fouling of the tubes may also occur. Webb and Li¹ tested a number of internally-enhanced condenser tubes at low velocity (3.51 ft/s [1.07 m/s]) and high water hardness.

While they found that some of the internally-enhanced tubes fouled in the long term, they concluded:

Because of the high hardness and low water velocity used in these tests, we do not believe that the fouling experienced is typical of that expected in commercial installations. With use of good maintenance practices and water quality control, all of the tubes tested are probably suitable for long-term-fouling applications.

It is important to remember that a chiller selected for low flow does not necessarily have low velocity through its tubes, as discussed in the chapter “System Design Options” on page 27. If tube fouling is a major concern, consider the use of smooth, rather than internally-enhanced, tubes in the condenser for ease of cleaning.

Air-cooled condenser

Packaged or Split System?

A number of different options are available for packaging and splitting the components of an air-cooled chiller. There is an excellent discussion in *Chilled-Water Systems*, part of the Air Conditioning Clinic Systems Series (TRG-TRC016-EN).

Air-cooled chillers do not use condenser-water, since they reject their heat by passing ambient air across refrigerant-to-air heat exchangers. In packaged air-cooled chillers, the manufacturers improve performance by staging fans in response to chiller load and ambient, dry-bulb temperature. Air-cooled chillers can also be split apart. One technique is to use an indoor remote evaporator with a packaged air-cooled condensing unit outdoors. Another technique is to locate the compressor(s) *and* the evaporator indoors (also known as a condenserless chiller) with an air-cooled condenser outdoors. It is also possible to have an indoor air-cooled condenser.

Air-cooled versus water-cooled condensers

One of the most distinctive differences in chiller heat exchangers continues to be the type of condenser selected—air-cooled versus water-cooled. When comparing air-cooled and water-cooled chillers, available capacity is the first distinguishing characteristic. Air-cooled condensers are typically available in packaged chillers ranging from 7.5 to 500 tons [25 to 1,580 kW]. Packaged water-cooled chillers are typically available from 10 to nearly 4,000 tons [35 to 14,000 kW].

Maintenance

A major advantage of using an air-cooled chiller is the elimination of the cooling tower. This eliminates the concerns and maintenance requirements associated with water treatment, chiller condenser-tube cleaning, tower mechanical maintenance, freeze protection, and the availability and quality of makeup water. This reduced maintenance requirement is particularly attractive to building owners because it can substantially reduce operating costs. However, see “Energy efficiency” below.

Systems that use an open cooling tower must have a water treatment program. Lack of tower-water treatment results in contaminants such as bacteria and algae. Fouled or corroded tubes can reduce chiller efficiency and lead to premature equipment failure.

Low-ambient operation

Air-cooled chillers are often selected for use in systems with year-round cooling requirements that cannot be met with an airside economizer. Air-cooled condensers have the ability to operate in below-freezing weather, and can do so without the problems associated with operating the cooling tower in these conditions. Cooling towers may require special control sequences, basin heaters, or an indoor sump for safe operation in freezing weather. For process applications, such as computer centers that require cooling year-round, this ability alone often dictates the use of air-cooled chillers.

Energy efficiency

Water-cooled chillers are typically more energy efficient than air-cooled chillers. The refrigerant condensing temperature in an air-cooled chiller is dependent on the ambient dry-bulb temperature. The condensing temperature in a water-cooled chiller is dependent on the condenser-water temperature, which is dependent on the ambient wet-bulb temperature. Since the design wet-bulb temperature is often significantly lower than the dry-bulb temperature, the refrigerant condensing temperature (and pressure) in a water-cooled chiller can be lower than in an air-cooled chiller. For example, at an outdoor design condition of 95°F [35°C] dry-bulb temperature, 78°F [25.6°C] wet-bulb temperature, a cooling tower delivers 85°F [29.4°C] water to the water-cooled condenser. This results in a refrigerant condensing temperature of approximately 100°F [37.8°C]. At these same outdoor conditions, the refrigerant condensing temperature in an air-cooled condenser is approximately 125°F [51.7°C]. A lower condensing temperature, and therefore a lower condensing pressure, means that the compressor needs to do less work and consumes less energy.

This efficiency advantage may lessen at part-load conditions because the dry-bulb temperature tends to drop faster than the wet-bulb temperature (see Figure 4). As a result, the air-cooled chiller may benefit from greater *condenser relief*. Additionally, the efficiency advantage of a water-cooled chiller is much less when the additional cooling tower and condenser pump energy costs are considered. Performing a comprehensive energy analysis is the best method of estimating the operating-cost difference between air-cooled and water-cooled systems.

Figure 4. Air-cooled or water-cooled efficiency

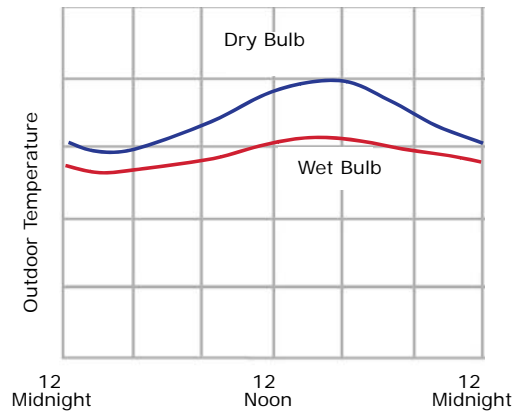

Another advantage of an air-cooled chiller is its delivery as a “packaged system.” Reduced design time, simplified installation, higher reliability, and single-source responsibility are all factors that make the factory packaging of the condenser, compressor, and evaporator a major benefit. A water-cooled chiller has the additional requirements of condenser-water piping, pump, cooling tower, and associated controls.

Water-cooled chillers typically last longer than air-cooled chillers. This difference is due to the fact that the air-cooled chiller is installed outdoors, whereas the water-cooled chiller is installed indoors. Also, using water as the condensing fluid allows the water-cooled chiller to operate at lower pressures than the air-cooled chiller. In general, air-cooled chillers last 15 to 20 years, while water-cooled chillers last 20 to 30 years.

To summarize the comparison of air-cooled and water-cooled chillers, air-cooled chiller advantages include lower maintenance costs, a pre-packaged system for easier design and installation, and better low-ambient operation. Water-cooled chiller advantages include greater energy efficiency (at least at design conditions) and longer equipment life.

Loads

In comfort-cooling applications, cooling loads are often satisfied by air handlers equipped with coils to transfer heat from the conditioned space air to circulating chilled-water. Air is cooled and dehumidified as it passes across the finned surface of the cooling coils. Since the psychrometric process of conditioning air takes place at the coils, selection of the optimum coil size and type from the wide variety available is important for proper system performance.

Some specialized process loads do not involve cooling air. Instead, they may involve heat transfer directly within a piece of process equipment, such as the cooling jacket of an injection-molding machine.

Heat transferred from the loads can be controlled in a number of ways:

- Three-way valve
- Two-way valve
- Variable-speed pump
- Face-and-bypass dampers

Three-way valve load control

A three-way control valve (Figure 5) regulates the amount of water passing through a coil in response to loads. The valve bypasses unused water around the coil and requires a constant flow of water in the system, regardless of load. A drawback of this bypass is that the temperature of the water leaving the three-way valve is reduced at part-load conditions. This can be a major contributor to so-called “low ΔT syndrome” discussed on page 79. Three-way valves are used in many existing systems, especially in those with constant-volume pumping.

Figure 5. Three-way valve

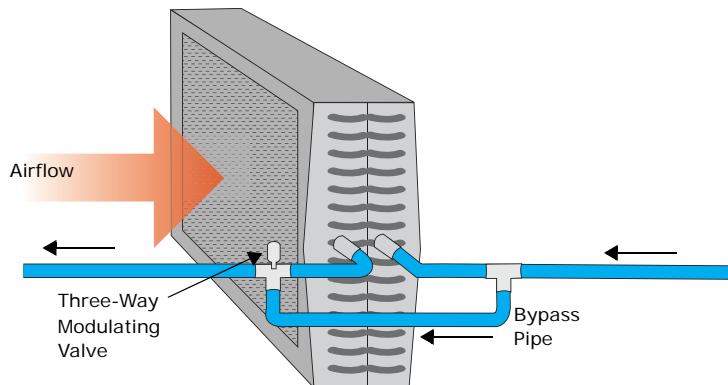

Two-way valve load control

A two-way, water modulating valve (Figure 6) at the coil performs the same water throttling function as the three-way valve. The coil sees no difference between these two methods. The chilled-water system, however, sees a great difference. In the case of the two-way valve, *all* flow in the coil circuit is throttled. No water is bypassed. Consequently, a system using two-way valves is a variable-flow chilled-water system. The temperature of the water leaving the coil is not diluted by bypass water so at part-load conditions, the system return-water temperature is higher than with three-way valve control.

Figure 6. Two-way valve

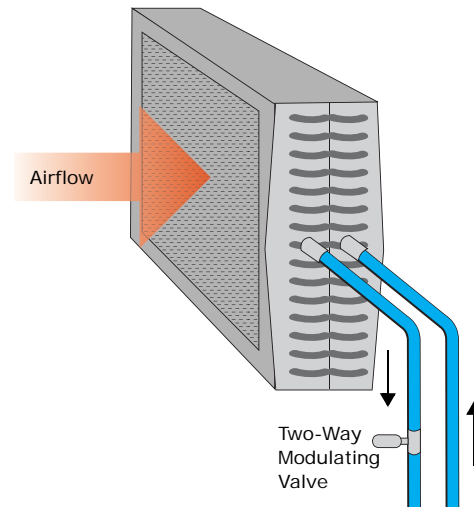

Variable-speed pump load control

By using a pump for each coil (Figure 7), the flow may be controlled by varying the pump speed. In such systems, there may be no control valves at the coil. This can reduce both the valve and the valve installation costs, but increases coil pump and maintenance costs.

Figure 7. Variable-speed pump load control

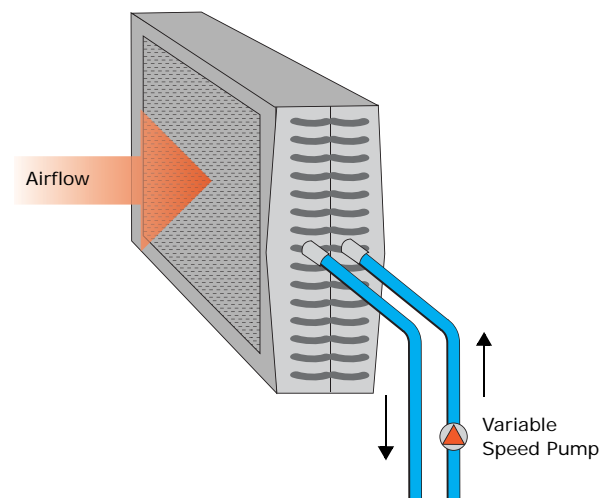

Face-and-bypass dampers

Figure 8 shows a control variation using an uncontrolled or “wild” coil. In this system, control of the conditioned air supply is executed by face-and-bypass dampers that permit a portion of the air to bypass the coil surface. Advantages of this strategy are the elimination of control valves and improved part-load dehumidification. A disadvantage is that all the water is

pumped all the time; however, in systems with very small water pressure drops, this system arrangement may work economically.

Figure 8. Uncontrolled water flow with bypass damper

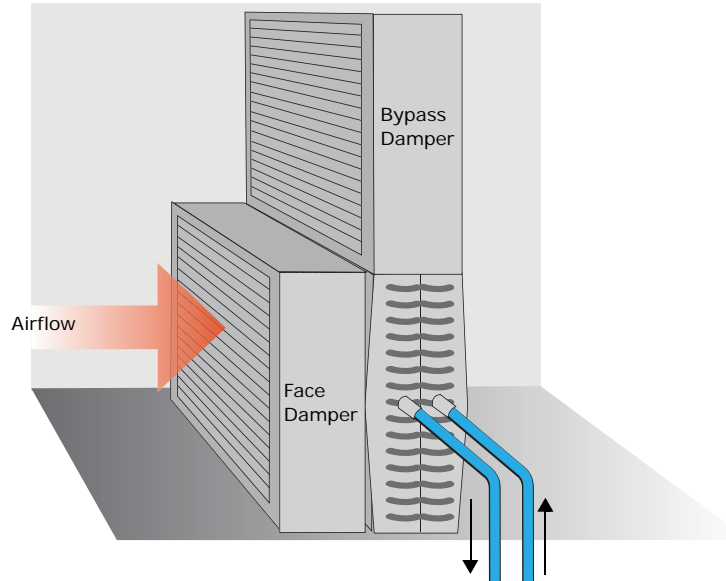

Chilled-Water Distribution System

Additional reference information on the components of a chilled-water distribution system is available in the *2008 ASHRAE HVAC Systems and Equipment Handbook*, chapter 12, "Hydronic Heating and Cooling System Design." **3**

Chilled water is circulated through fixed piping—most commonly steel, copper, or plastic—that connects the chiller with various load terminals. Piping is sized to meet pressure loss, water velocity, and construction cost parameters.

Chilled-water pump

The chilled-water pump creates pressure to circulate chilled water within the loop. Generally, the pump must overcome the frictional pressure losses caused by the piping, coils, and chiller and the pressure differential across open control valves in the system. The pump, while working at the system static pressure, does not need to overcome this static pressure. For example, in a forty-story building, the pump need not overcome the static pressure due to those forty stories.

The chilled-water pump is typically located upstream of the chiller; however, it may be anywhere in the system, provided that the pump:

- meets the minimum pump net positive suction-head requirements. That is, the system pressure at the pump inlet must be both positive and high enough to allow the pump to operate properly;
- maintains the minimum dynamic pressure head at critical system components (usually the chiller). If the dynamic pressure head is not high enough at these components, proper flow will not be established through them;

Primary System Components

- accommodates the total pressure (static head plus dynamic head) on system components such as the chiller's evaporator, valves, etc.

Note that the pump heat is added to the water and must be absorbed by the chiller. Generally, this represents a very small temperature increase.

Multiple pumps are often used for redundancy. Depending on the terminal control devices and system configurations, the chilled-water pumps may be either constant- or variable-flow.

As previously stated, pumps may be either on the inlet or the outlet of the chiller, as long as the inlet of the pump experiences an adequate, positive suction pressure. In applications where there is a significant liquid column head (for example, a high-rise building), the pump is often located at the chiller's *outlet* so that the evaporator bundle is subject only to the static head (rather than the static head plus the dynamic head added by the pump). The need for high-pressure water boxes on the chiller can be eliminated.

Conversely, an advantage of locating the pump at the chiller's inlet is that if the pump motor rejects its heat to the water, the heat can be removed directly by the chiller. The chiller does not need to compensate for the pump heat by making colder water.

Figure 9. Pump per chiller

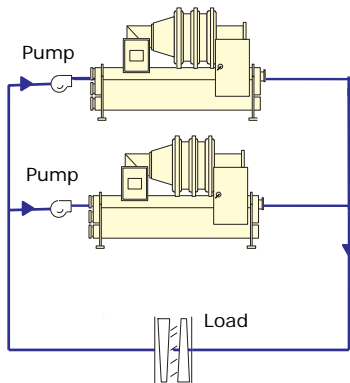
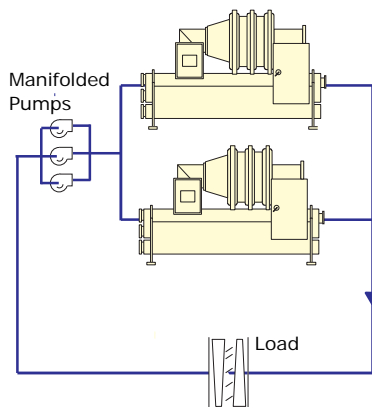

Figure 10. Manifolded pumps



Pump per chiller

In either a primary–secondary or variable-primary-flow system, using one pump per chiller simplifies system hydraulics (Figure 9). The pump can be selected to produce the flow and pressure drop necessary for the specific chiller. Bringing on additional pumps changes system hydraulics, but only minimally. One drawback of such a system is a lack of redundancy, since the pump and chiller are dedicated to one another. This may be overcome by using a spare pump, pipes, and valves so that the spare pump could work with any chiller during emergency conditions.

Manifolded pumps

In an effort to resolve the redundancy consideration, some designers prefer to manifold pumps and provide $n+1$ pumps, where n is the number of chillers (Figure 10). Such an arrangement allows any pump to be used with any chiller. However, system hydraulics become more complicated. Unless all piping runs and evaporator pressure drops are equal, the amount of water flowing to each chiller will differ. As discussed in "Moderate 'low ΔT syndrome'" on page 68, manifolded pumps present a control opportunity when low ΔT is experienced.

Either pump configuration can be successful; one pump per chiller simplifies the hydraulics, while manifolded pumps allow redundancy.

Distribution piping

By itself, the distribution system is easy to understand. Figure 11 shows a simplified distribution system consisting of multiple cooling coils, each controlled by a thermostat that regulates the flow in its respective coil. The

valves may be either three-way or two-way. As previously discussed, three-way valves require constant water flow, while two-way valves allow the water flow in the system to vary. As flow varies, the pump may simply ride its curve or use a method of flow control such as a variable-speed drive. Refer to the chapter "System Configurations" on page 42 for a detailed discussion of distribution-system options.

Figure 11. Simplified distribution system

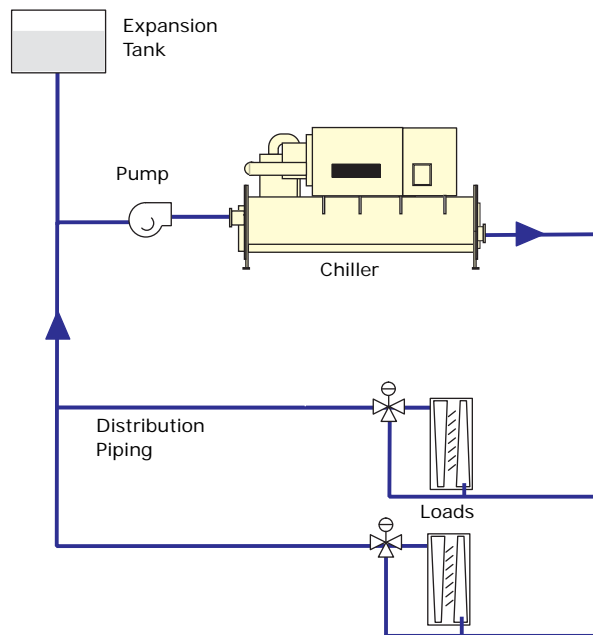

The distribution system may contain other components, such as an expansion tank, control valves, balancing valves, check valves, and an air separator, to name a few. The density, and therefore the volume, of the water in a "closed" chilled-water distribution system varies as it undergoes changes in temperature. The expansion tank allows for this expansion and contraction of water volume.

Figure 12. Constant flow system

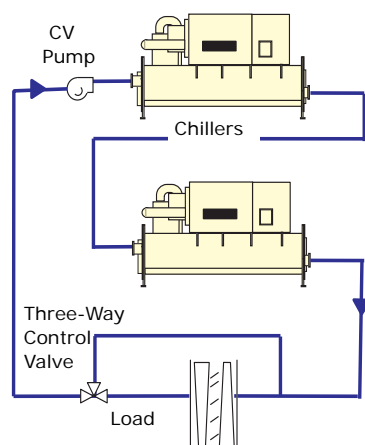

Pumping arrangements

Variations on three basic pumping arrangements are common. They are referred to as constant flow, primary-secondary (decoupled) flow, and variable-primary flow (VPF). The implications and nuances of each of these is discussed in greater detail in "System Configurations" on page 42.

Constant flow system

When a chiller is on, a constant speed pump dedicated to it is on, and there need not be any other pumps operated in the system (Figure 12). This is a simple system and makes the most sense when there will only be one chiller operated at a time in the system. Challenges with this system arise at part load when chillers are in the parallel arrangement (refer to "Parallel Chillers" on page 42). To solve some of these problems, the chillers can be placed in

Primary System Components

Figure 13. Primary-secondary system

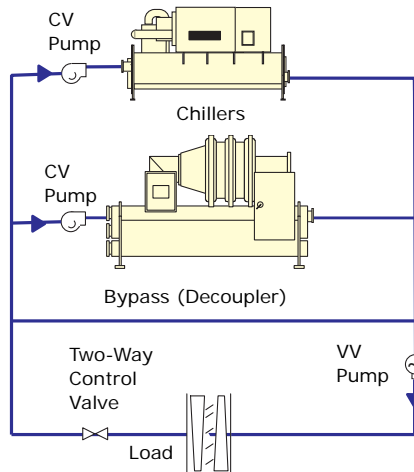
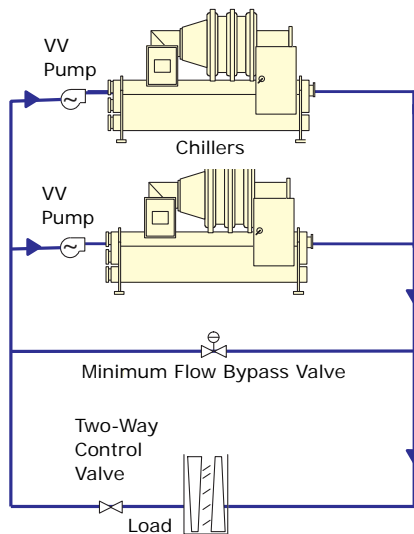

Figure 14. Variable-primary system



the series, or another pumping arrangement can be considered. Reducing the flow rate affects this system type's energy use all the time, so careful attention to flow rates and temperature is critical (refer to "System Design Options" on page 27).

Primary-secondary system

In this configuration (Figure 13), the distribution piping is decoupled from the chiller piping and is known as the primary-secondary or decoupled system. There is constant primary flow through the operating chiller(s) and variable secondary flow through the loads. A bypass pipe between the two balances the primary flow with the secondary flow. Because there are more pumps and a bypass, this system costs more than a constant flow system to install. Details on this system type are in "Primary-Secondary (Decoupled) Systems" on page 45.

Variable-primary system

This pumping arrangement (Figure 14) was made possible in recent years by advanced chiller controls that permit varying the flow through the chillers. Like a constant flow system, the distribution piping is directly connected to the chiller piping. Flow is varied through at least most of the loads and the chillers. A smaller bypass (compared to the primary-secondary system) ensures chiller minimum flow rates are avoided. Fewer pumps and smaller bypass lead to lower first costs compared to the primary-secondary system. Operation costs can also be lower, but the plant is controlled differently than in other pumping arrangements and operator training is essential. This system type is covered in detail in "Variable-Primary-Flow Systems" on page 55.

Condenser-Water System

As in chilled-water distribution systems, condenser-water system piping—most commonly steel, copper, or plastic—is sized to meet a project's operating pressure, pressure loss, water velocity, and construction cost parameters. Pressure drop through piping and the chiller's condenser, plus the cooling tower static lift, is overcome by use of a condenser-water pump.

To ensure optimum heat transfer performance, the condenser-heat transfer surfaces must be kept free of scale and sludge. Even a thin deposit of scale can substantially reduce heat transfer capacity and chiller efficiency. Specifics of cooling-tower-water treatment are not discussed in this manual. Engage the services of a qualified water treatment specialist to determine the level of water treatment required to remove contaminants from the cooling tower water.

Cooling tower

To reject heat, water is passed through a cooling tower where a portion of it evaporates, thus cooling the remaining water. A particular cooling tower's effectiveness at transferring heat depends on water flow rate, water temperature, and ambient wet bulb. The temperature difference between the

water entering and leaving the cooling tower is the range. The temperature difference between the leaving water temperature and the entering wet-bulb temperature is the approach.

Effect of load on cooling tower performance

As the building load—or heat rejection—decreases, range and approach also decrease. This means that when the building is at part load, the cooling tower can provide colder water at the same ambient wet-bulb temperature.

Effect of ambient conditions on cooling tower performance

As ambient wet-bulb temperature drops, the approach—at a constant load—*increases*. This is counter-intuitive to many, and it must be considered when cooling-tower-control strategies are developed. Detailed descriptions of these conditions appear in “Chiller–tower energy balance” on page 91. For additional information, refer to *2008 ASHRAE HVAC Systems and Equipment Handbook*, chapter 39, “Cooling Towers.”³

Condenser-water pumping arrangements

Water-cooled chillers require condenser-water-system variations to be considered. For a discussion of condenser-water temperatures and flow rates, refer to “System Design Options” on page 27. Since air-cooled-chiller condenser controls are part of the chiller design, they are not discussed in this manual.

Most important, the inlet to the pump must have sufficient net positive head. This often means locating the pump below the cooling-tower sump.

Single tower per chiller

In some applications each chiller has a dedicated cooling tower. This is most likely to occur when chillers, and their accompanying towers, are purchased at different times during the facility’s life—such as when additions are made.

Manifolded pumps

A much-used pumping arrangement has a single cooling-tower sump with manifolded pumps, one condenser water line, and separate, smaller, pipes for each chiller as shown in Figure 15. This provides a number of advantages:

- Pumping redundancy
- If cooling towers cells can be isolated, any cooling-tower cell can run with any chiller.
- Hydraulics are generally less problematic than on the chilled-water side.
- Cooling towers can be located remotely from chillers, with only a single supply and return pipe to connect them.

Figure 15. Manifolded condenser-water pumps

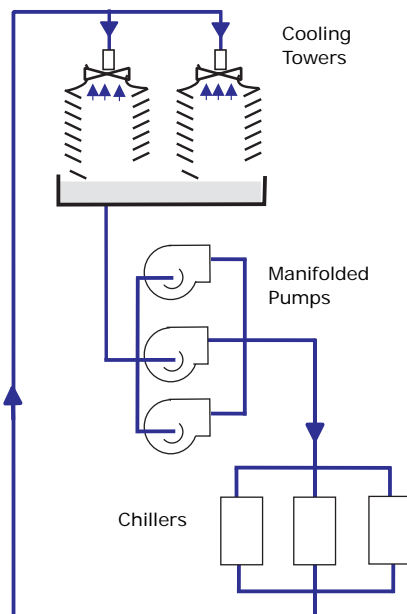

Unit-Level Controls

The chilled-water supply temperature is usually controlled by the chiller. Most commonly, supply water temperature is used as the sensed variable to permit control of chiller capacity to meet system load demand. Supply-temperature control strategies may be used on either constant- or variable-flow systems. As previously discussed, flow control is executed at the load terminals using three-way or two-way valves, or separate pumps for each coil. Control capabilities run the gamut from slow-acting pneumatic controls, to electromechanical controls, to sophisticated digital controls that use "feed-forward" algorithms tuned to give superior performance.

Chiller control

Today's chiller controls are capable of doing more than simply turning the chiller on and off. At a minimum, these controls should monitor:

- Safety points, such as bearing temperatures and electrical points, that may cause motor failure when out of range.
- Data points that may cause operational problems if corrective action is not taken. An example is low chilled-water or refrigerant temperature, which may result in freezing in or around the evaporator tubes.
- General points to ensure proper chiller performance and refrigerant containment.

Table 1. Recommended chiller-monitoring points per ASHRAE Standard 147⁴

	Flow		Flow
Chilled Water (or other secondary coolant)	Inlet Pressure	Condenser Water	Inlet Pressure
	Inlet Temperature		Inlet Temperature
	Outlet Pressure		Outlet Pressure
	Outlet Temperature		Outlet Temperature
Evaporator	Refrigerant Pressure	Condenser	Refrigerant Pressure
	Refrigerant Temp.		Refrigerant Temp.
Oil	Level	Refrigerant	Level
	Pressure		Compressor Discharge Temp.
	Temperature		Compressor Suction Temp.
	Addition of		Addition of (in Refrigerant Log)
Vibration Levels			PPM Refrigerant Monitor Level
Purge	Exhaust Time	Logs	Date and Time Data
	Discharge Count		Signature of Reviewer
Ambient Temperatures	Dry Bulb	Motor	Amperes Per Phase
	Wet Bulb		Volts Per Phase

In addition to monitoring data, it is vital that the chiller controls alert operators to possible problems. Diagnostic messages are necessary for the operator to respond to safety issues and data points that are outside normal operating ranges. While communicating these diagnostic messages is a requirement, some chiller controls include factory-installed programming that responds to the issue causing the diagnostic messages. For example, when the chilled-water temperature nears freezing, the chiller sends a diagnostic message and adapts its operation by reducing the compressor capacity, raising the chilled-water temperature to a safer condition.

Finally, the chiller controls should communicate with a system-level controller. There are many system aspects that are outside the chiller's direct control, such as condenser-water temperature and the amount of fluid flowing through the evaporator and condenser. To minimize the system energy costs, the system controls must coordinate chiller, pump, cooling-tower, and terminal-unit controls. This can only be done if adequate information is communicated from each system component to the system-level controls. System-level control is discussed in detail in "System Controls" beginning on page 87.

Centrifugal chiller capacity control

For more information about chillers, Trane Air Conditioning Clinics are available for centrifugal (TRG-TRC010-EN), absorption (TRG-TRC011-EN) and helical-rotary (TRG-TRC012-EN) chiller types.

The capacity of a centrifugal chiller can be modulated using inlet guide vanes (IGV) or a combination of IGV and a variable-speed drive (adjustable-frequency drive, AFD)(Figure 16). Variable-speed drives are widely used with fans and pumps, and as a result of the advancement of microprocessor-based controls for chillers, they are being applied to centrifugal water chillers.

Figure 16. Centrifugal chiller with AFD

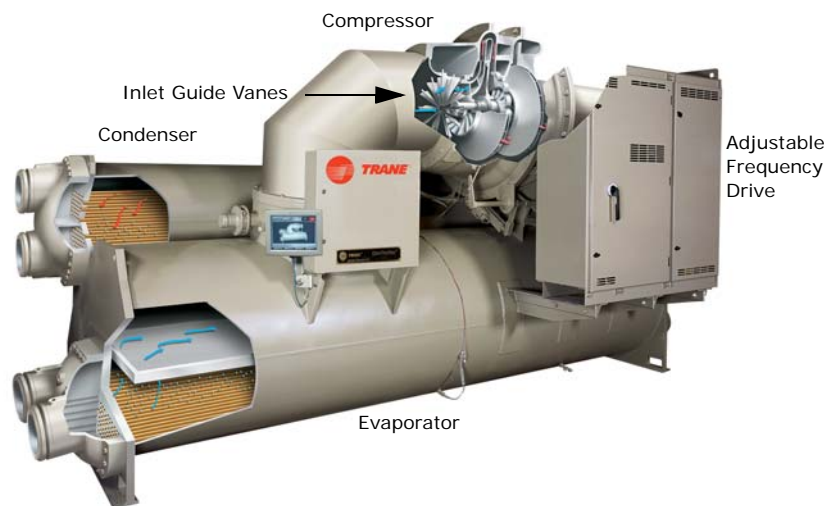

ASHRAE 90.1 requires a chiller to meet both full and part-load efficiency requirements. Using an AFD with a centrifugal chiller degrades the chiller's full-load efficiency. This causes an increase in electricity demand or real-time pricing charges. At the time of peak cooling, such charges can be ten (or more) times the non-peak charges. In return, an AFD can offer energy savings

by reducing motor speed at “low-lift” conditions, when cooler condenser water is available.

Certain system characteristics favor the application of an AFD, including:

- A substantial number of part-load operating hours (for example, when an air- or water-economizer is not installed in the system)
- The availability of cooler condenser water (condenser-water reset)
- Chilled-water reset control

Chiller savings using condenser- and chilled-water-temperature reset, however, should be balanced against the increase in pumping and cooling-tower energy. Performing a comprehensive energy analysis is the best method of determining whether an AFD is desirable. It is important to use actual utility costs, not a “combined” cost, for demand and consumption charges. It is also important to include drive maintenance and replacement costs, since the drive life is shorter than the chiller life. See “Energy and economic analysis of alternatives” on page 26.

Depending on the application, it may make sense to use the additional money that would be needed to purchase an AFD to purchase a more efficient chiller instead. This is especially true if demand charges are significant, or if the condenser water is close to its design temperature most of the time (e.g., in a hot and humid climate such as Miami).

Consider the following analysis of an 800-ton office building with two chillers. The analysis compares equally priced high efficiency or AFD-equipped chillers, as one or both of the chillers. Utility costs for the combined or “blended” rate are \$0.10 per kWh and for the actual rate are \$12 per kW and \$0.06 per kWh.

Simple paybacks using the combined rate analysis show almost no difference between the two options (Table 2). However, when utility costs with an actual consumption and demand component are used, the difference between the alternatives is much more pronounced. The conclusion is that using actual energy rates matters a great deal.

Table 2. Analysis of high-efficiency chiller options with combined vs actual rates

Simple paybacks, humid climate	Combined rate	Actual rate
AFD on both chillers	7.2	12.7
High efficiency on both chillers	7.1	8.3
AFD on one chiller	6.1	10.8
High efficiency on one chiller	6.3	7.7

Application Considerations

Chiller system size affects design and control considerations. Each size comes with its own set of advantages and challenges.

Small Chilled-Water Systems (1-2 chillers)

Figure 17. Small chilled-water system schematic

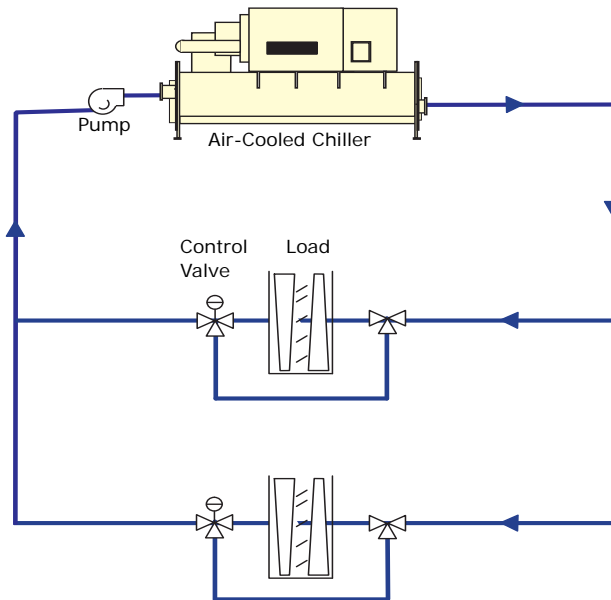

A common design goal for the small chilled-water system with one or two chillers (Figure 17) is to minimize complexity while balancing energy consumption goals. Smaller chilled-water systems may have smaller budgets allotted for operation and maintenance and may run unattended more often than larger systems. Keeping it simple, while capitalizing on chilled water advantages, is the hallmark of a successful project.

The first cost of a small system is a common hurdle faced by a building owner. There are ways to minimize first costs without sacrificing operating costs. For example, a wider design ΔT reduces flow rates, which in turn reduces pipe and pump sizes. In addition to reducing pump and pricing costs, this may also allow the designer to avoid installing a storage tank to meet the required chiller "loop times." (See "Amount of Fluid in the Loop" on page 79.) On a system with multiple chillers, using a variable-primary-flow design ("Variable-Primary-Flow Systems" on page 55) can reduce the number of pumps, starters, electrical equipment, and space required.

Constant flow

Constant flow is simple and often applied to small systems up to 200 tons— as long as the system pressure drop is fairly low and a wider ΔT is applied to reduce the system flow rate. In constant flow systems, appropriate chilled-water reset reduces chiller energy. These two strategies for saving energy (reducing flow rates and/or chilled-water temperature reset) can be used successfully in the constant flow designs more common in small chilled-water systems. These two strategies are covered in “Selecting Chilled- and Condenser-Water Temperatures and Flow Rates” on page 27 and “Chilled water reset—raising and lowering” on page 87.

Constant flow systems use either a balancing or pressure-reducing valve or, in a few cases, trim the pump impeller to set the system design flow. Pressure-reducing valves waste pump energy. Another option designers use to reduce pumping energy and increase system flexibility is to install a variable frequency drive on the pump motor and set it at a constant speed during system commissioning.

If, instead, system flow is balanced by trimming the pump impeller, flow adjustment is much more difficult. Using a variable frequency drive at a set speed allows the flow to be decreased or increased in the future if necessary. This approach is more cost effective because the cost of variable frequency drives has dropped. Any incremental cost will be offset by the elimination of the balancing valves and pump starter.

Variable flow

Although a variable-primary-flow system may cost more than a constant flow system, it is growing in popularity because it is less expensive than installing a decoupled system. Another reason for its increased popularity is that pump energy is reduced.

Some owners are concerned that the controls are more complex, but variable flow systems can work very simply in the small chilled-water system when there is only one chiller or when two chillers are piped in series. Key control issues for variable flow systems are discussed in “Variable-Primary-Flow Systems” on page 55, and variable flow with series chillers in “Series Chillers” on page 44.

Condensing method

Many small chilled-water systems use air-cooled chillers because of the lower maintenance requirements of the condensing circuit. Water-cooled systems are generally more energy efficient and have more options for features such as heat recovery, though some air-cooled chillers have partial heat recovery options.

To help the owner decide on the system selection, a comprehensive energy analysis is the best method of estimating the life cycle cost difference between air-cooled and water-cooled systems. Energy analysis is likely required for many facilities seeking LEED certification, so it may already be

part of those jobs. See “Energy and economic analysis of alternatives” on page 26.

Number of chillers

The number of chillers to install is a function of redundancy requirements and first cost. In general, the more chillers installed, the higher the initial cost. Therefore, many small systems only use one chiller. Most chillers in the 20 through 200 ton range use multiple compressors with multiple refrigeration circuits and provide a reasonable level of cooling redundancy. The only system controls installed on a single chiller installation may be a clock and ambient lockout switch to enable and disable the chilled-water system. If only one chiller is used, a system that varies the flow rate through the chiller can be quite simple to operate. Minimum and maximum flows and maximum rate of change for the flow would still need to be addressed (see “Variable-Primary-Flow Systems” on page 55).

As systems get larger, the owner may require more redundancy, leading them to install multiple chillers. Some designers use 200 tons as the maximum job size for a single chiller.

When there is more than one chiller, there are many more system control decisions to be made including:

- enabling the second chiller,
- turning the second chiller off, and
- failure recovery.

Two-chiller plants require higher system control intelligence than single chiller plants. Sequencing logic, discussed in “System Configurations” on page 42, varies based on system configuration, and failure recovery is discussed on page 95.

Parallel or series

Parallel configurations are more common than series configurations. (See “Parallel Chillers” on page 42.) In chiller systems with an even number of chillers, there are advantages to putting them into a series configuration, especially if low or variable water flow is desired. This offers the benefits of better system efficiency and higher capacity because the upstream chiller produces water at a warmer temperature. Series chillers should not be applied with low system ΔT s, because the maximum flow through the chillers may be reached. Efforts to eliminate the so-called “Low ΔT syndrome” (page 79) must be addressed for both configurations. The energy and control requirements of series chillers are covered in “Series Chillers” on page 44.

Part load system operation

For small chilled-water systems, especially those with only one chiller, part load system energy use may be dominated by ancillary equipment, especially in a constant flow system. At low loads, constant speed pumps and tower fans constitute a much larger portion of the chiller plant energy

than at full load. Variable frequency drives for unloading tower fans and chilled-water pumps may provide benefits, depending on the costs, system operating hours, system type, and outdoor air conditions. (See “System Controls” on page 87.)

Mid-Sized Chilled-Water Systems (3-5 Chillers)

Figure 18. Mid-sized chilled-water system schematic

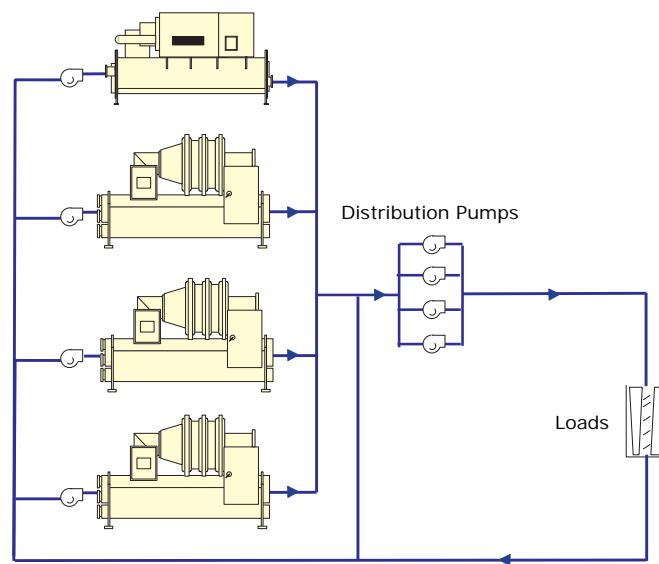

In addition to the design decisions faced by the small chilled-water system designer, the following objectives may be encountered by the mid-sized system designer.

Managing control complexity

As chilled-water systems get larger (Figure 18), control system design and execution become more critical and more complex. There are simply more combinations of equipment and operating scenarios. On the other hand, systems this size generally have more highly-skilled operators who can understand proper operation and maintenance. To help operators understand expected system operation, chiller plant controls are usually more customized and sophisticated.

Preferential vs. equalized loading and run-time

With more chillers, sequencing options might include preferentially loading the most efficient chiller or equalizing the run time of chillers. The decision hinges on how different these chillers are and the preferred maintenance routine. For example, a chiller plant with one quite old—though still reliable—chiller may periodically enable that chiller to ensure it continues to function,

but use it sparingly due to its lower efficiency. Or, a chiller may have a different fuel source, used as a hedge against either high demand or high energy consumption charges for other energy sources. (See “Alternative Energy Sources” on page 82.) Some chilled-water systems have unequally sized chillers, allowing fewer chillers to operate. (See “Unequal Chiller Sizing” on page 78.)

Large Chilled-Water Systems (6+ Chillers, District Cooling)

Figure 19. Large chilled-water system schematic

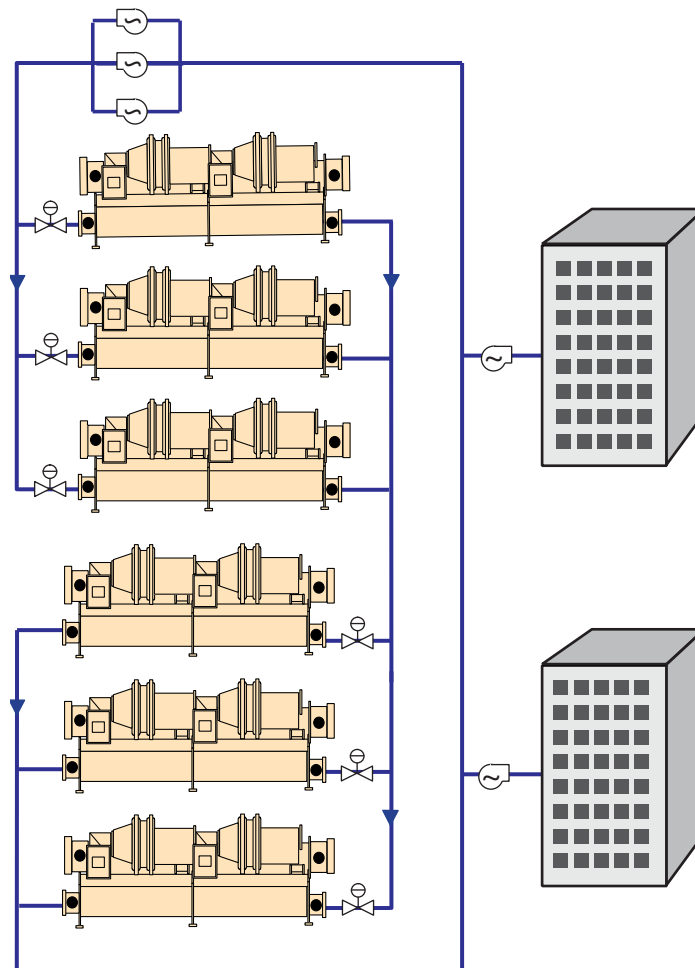

Large chilled-water systems with six or more chillers (Figure 19) have different challenges than smaller systems. Examples of these types of systems are commonly found on campuses with multiple buildings, downtown districts, and mixed-use residential and commercial developments.

Creating one centralized chilled-water system takes significant foresight, initial investment, and building development with a multi-year master plan. If the initial plant is built to accommodate many future buildings or loads, the early challenge is operating the system efficiently with much lower loads than it will experience when the project is complete. The system may need to blend parallel and series configurations (“Series–Counterflow Application” on page 77) to accommodate the wide range of loads the plant experiences during phased construction.

Another type of large chilled-water system could actually start out as more than one chilled water-system. An existing set of buildings can be gradually added to the central system, or two geographically distant chilled-water systems can be connected. “Plant Expansion” on page 83 discusses the unique control and hydraulic challenges of “double-ended” chilled-water systems.

Operating large chilled-water systems can be different as well. As system load drops, chillers are turned off. *Individual* chiller unloading characteristics are not as important, because operating chillers are more heavily loaded.

Pipe size

Practical pipe size limitations start to affect the maximum size of a chilled-water system. As the systems get larger, it becomes more difficult to accommodate the increasing pipe sizes, both in cost and in space. Large ΔT s can help reduce flow and required pipe size. (See “Selecting Chilled- and Condenser-Water Temperatures and Flow Rates” on page 27.) In general, the larger the system, the higher the ΔT should be.

Water

Large systems are almost always water-cooled. Both chilled water (a closed loop) and condenser water (usually an open loop) pipes will have to be filled with water. In some locations, it is difficult to find enough fresh water to fill a very large system with water, especially if the chilled-water system is quite distant from the loads. Cooling towers consume water, which can be significant and difficult to obtain in some locations. The search for both locally available make-up water and energy savings can lead to the exploration of alternative condensing sources like lake, river, or well water. (See “Well, river, or lake water” on page 72.) In rare instances, salt water or brackish water can be applied if the system uses an intermediate heat exchanger, or if the chiller is constructed with special tubes.

Power

Large chilled-water systems can be challenged by site power availability. Transformer size may be dictated by local regulations. On-site power generation may be part of the project, leading to using higher voltages inside the chilled-water system to avoid transformer losses and costs. Alternative fuels for some or all of the chillers may be attractive (“Alternative Energy Sources” on page 82).

To minimize power, large systems must be very efficient. The upside of a large system is the amplification of energy savings. A relatively small percentage of energy saved becomes more valuable. For this reason, the highly efficient series-counterflow arrangement is popular for large systems. (See “Series-Counterflow Application” on page 77.)

Controls

The designers of medium and large chilled-water systems are more likely to consider the pros and cons of direct-digital controls (DDC) versus programmable-logic controls (PLC). These platforms deliver similar results, depending on proper design, programming, commissioning, and operation.

One way to think of PLC is “fast, centralized control with redundancy.” PLC has a faster processing speed, with some hot-redundancy features—such as an entirely redundant system processor that is ready to take over if the main system processor fails.

Conversely, DDC can be considered “steady, distributed control with reliability.” DDC controls feature easy programming and user-friendly operation. In the DDC environment, a failure of the system processor results in the lower-level processors defaulting to a pre-determined operating mode.

The speed of the PLC system can be one of its challenges. Controls that are steady and do not overreact to minor changes work very well, even in large chilled-water systems.

Chiller Plant System Performance

Chiller performance testing

All major chiller manufacturers have chiller performance test facilities in the factory, in a laboratory, or both. A chiller performance test in accordance with the test procedures in ARI Standard 550/590⁵ can be performed at the factory under controlled conditions, with industrial grade instrumentation and computerized data collection devices. This test ensures that the chiller meets its promised performance criteria. If it does not, corrections are made before it leaves the factory.

Limitations of field performance testing

After the chiller is installed at the job site, the system conditions will be less controllable than in a test facility, and therefore unsuitable for chiller acceptance testing. While measuring the performance of the entire chiller plant is more difficult, it can help identify operating problems or evaluate the effectiveness of system control methods and setpoints.

The goal is to operate as efficiently as possible and to sustain a high level of individual equipment *and* coordinated operation. A proper energy management system can help trend and diagnose problems or changes over time.

For more information about chiller plant controls, consult the Trane applications guide, *Tracer Summit™ Chiller Plant Control Program* (BAS-APG004-EN).

Guidelines for system efficiency monitoring

For a copy of ASHRAE Guideline 22 and other ASHRAE publications, visit the ASHRAE bookstore at www.ashrae.org/bookstore.

ASHRAE Guideline 22 *Instrumentation for Monitoring Central Chilled-Water Plant Efficiency*⁶ was first published in June 2008. It states:

Guideline 22 was developed by ASHRAE to provide a source of information on the instrumentation and collection of data needed for monitoring the efficiency of an electric-motor-driven central chilled-water plant. A minimum level of instrumentation quality is established to ensure that the calculated results of chilled-water plant efficiency are reasonable. Several levels of instrumentation are developed so that the user of this guideline can select that level that suits the needs of each installation.

The basic purpose served by this guideline is to enable the user to continuously monitor chilled-water plant efficiency in order to aid in the operation and improvement of that particular chilled-water plant, not to establish a level of efficiency for all chilled-water plants. Therefore, the effort here is to improve individual plant efficiencies and not to establish an absolute efficiency that would serve as a minimum standard for all chilled-water plants.

Guideline 22 includes a discussion of:

- types of sensors and data measurement devices
- calibration
- measurement resolution, accuracy, and uncertainty
- calculation methods
- example specification
- examples of measured long-term performance

Guideline 22 recommends tracking and archiving the following over the life of the plant, in addition to normal equipment operating trends. The ability to obtain this information is dependent on the instrumentation and data measurement capabilities of the system.

- 1 Average day's outdoor air temperature (obtain the outside air temperature every 30 minutes and find the average of these samples each day)
- 2 Day's high temperature
- 3 Day's low temperature
- 4 Day's high wet-bulb temperature (calculate from temperature and enthalpy)
- 5 Chilled-water supply temperature (average, max and min if chilled-water temperature is not fixed)
- 6 Total ton-hours (kWh) production of chilled water for the day
- 7 Total kWh power input for each component for the day
- 8 Average kW/ton (COP) for the plant for the day

Energy and economic analysis of alternatives

Prominent software for energy analysis includes TRACE[™], System Analyzer[™], eQuest, and EnergyPlus.

The process of making decisions between multiple, competing alternatives is simplified with the assistance of simulation software. Many packages are available for this purpose (see sidebar). While not every analysis will require the same level of detail for decision-making purposes, computer-assisted analysis computations are now easy and fast, and it is no longer necessary to make many simplifying assumptions. When performing a simulation of alternatives, use software that allows for:

- 1 Full year analysis
 - a Schedules, including holidays, affect the loads and the equipment.
 - b Weather, including coincident temperature, solar, and wind effects will have an effect, not just on the loads but on the energy performance of equipment.
- 2 Actual energy rate definition
 - a Time-of-day and time-of-year rate capabilities are important. Some utilities stipulate that some hours and/or months are “on peak,” while others are “mid peak” or “off peak,” and charge differently.
 - b Demand or other fixed costs are almost always present in some fashion, so that utilities are compensated for the amount of instantaneous capacity they provided. Some rates will include “ratchet” clauses, which charge a minimum percentage of the previous 12 months’ peak demand.
 - c Stepped-rates, also known as floating cut-offs, are used to reward energy consumers with flatter load profiles. The amount of energy used almost all the time will have the least expensive rate.
 - d Blended or combined electricity rates are not acceptable (see sidebar).
- 3 Life-cycle analysis
 - a First costs are rarely overlooked in an economic analysis.
 - b Maintenance costs also are likely to be different in each alternative.
 - c Replacement costs will be important when evaluating alternatives with equipment not expected to have the same useful life, or if one alternative is to delay some amount of action by one or more years.
 - d Escalation factors on recurring costs such as maintenance and energy.
 - e More advanced economic parameters may be desirable as well to include financing and tax implications.

Blended electricity rates computed from a full year’s energy cost divided by the full year’s kWh are not acceptable. Not every alternative will use energy the same way, and not every unit of energy will have the same effective cost. See Table 2, “Analysis of high-efficiency chiller options with combined vs actual rates,” on page 17.

ASHRAE Standard 140⁷ was developed to create a basis for defining and testing capabilities of energy analysis software packages. Test results are submitted to ASHRAE and publicly available before software is considered compliant with the Standard.

For the purposes of achieving ASHRAE Standard 90.1 compliance using the Energy Cost Budget method, or for certifications under the United States Green Building Council’s LEED[®] program, software tools must be tested in accordance with ASHRAE Standard 140. This test is also required for tax incentives offered by the United States federal government.

System Design Options

There are many chilled-water-system design options; however, in a basic sense, each option is a function of flow, temperature, system configuration, and control. This section discusses the effect of flow rate and temperature decisions.

It is important to remember that temperatures and flow rates are variables. By judicious selection of these variables, chilled-water systems can be designed to both satisfy chilled-water requirements and operate cost effectively.

For more information, refer to ARI Standard 550/590-2003, *Performance Rating of Water Chilling Packages Using the Vapor Compression Cycle* and the ARI Standard 560-2000, *Absorption Water Chiller and Water Heating Packages*. Both are published by the Air-Conditioning, Heating, and Refrigeration Institute. www.ahrinet.org

Chilled-water systems are often designed using flow rates and temperatures applied in testing standards developed by the Air-Conditioning, Heating, and Refrigeration Institute (AHRI), ARI 550/590–2003 for vapor compression chillers and ARI 560–2000 for absorption chillers (see sidebar). These benchmarks provide requirements for testing and rating chillers under multiple rating conditions. They are *not* intended to prescribe the proper or optimal flow rates or temperature differentials for any particular system. In fact, as component efficiency and customer requirements change, these standard rating conditions are seldom the optimal conditions for a real system, and industry guidance recommends lower flow rates with resultant higher temperature differences. There is great latitude in selecting flow rates, temperatures, and temperature differences.

Selecting Chilled- and Condenser-Water Temperatures and Flow Rates

Leaving chilled-water and entering condenser-water temperature selection can be considered independently of their respective flow rates. However, temperatures and flow rates should be selected together to design an efficient and flexible chilled-water system.

Guidance for Chilled- and Condenser-Water Flow Rates

The *ASHRAE GreenGuide*⁸ (pp 146-147) states:

In recent years, the 60% increase in required minimum chiller efficiency from 3.80 COP (ASHRAE Standard 90-75) to 6.1 COP (ASHRAE Standard 90.1-2004) has led to reexamination of the assumptions used in designing hydronic media flow paths and in selecting movers (pumps) with an eye to reducing energy consumption... Simply stated, increase the temperature difference in the chilled water system to reduce the chilled-water pump flow rate...

The *CoolTools*[™] *Chilled Water Plant Design Guide* recommends starting with a chilled-water temperature difference of 12°F to 20°F [7°C to 11°C], and it

recommends a design method that starts with condenser-water temperature difference of 12°F to 18°F [7°C to 10°C].

Standard rating temperatures

Currently, the standard rating condition temperatures in ARI 550/590⁵ and ARI 560⁹ are:

- Evaporator leaving water temperature: 44°F [6.7°C]
- Water-cooled condenser, entering water temperature: 85°F [29.4°C]
- Air-cooled condenser, entering air dry bulb: 95°F [35.0°C]

For years, these temperature definitions were the benchmarks in system designs. Today, designers apply a variety of different temperatures. ARI 550/590 reflects this trend by allowing the chilled-water and condenser-water temperatures to be selected at non-standard points and the chiller to be tested as specified by the standard.

Chilled-Water Temperatures

Chilled water (without antifreeze) at 34°F (1.1°C) is possible with some chillers that use sophisticated evaporator-design and chiller-control methods.

Currently, comfort cooling systems are designed with chilled-water supply temperatures that range from 44°F [6.7°C] to 38°F [3.3°C], and, in some cases, as low as 34°F [1.1°C]. Reasons to decrease the chilled-water temperature include the following:

- The system design more readily accommodates wider temperature differences (lower flow rates) than the standard rating conditions (see “Selecting flow rates” on page 30).
- Lower water temperature allows lower air temperatures (and flows) to be selected, resulting in reduced airside installed and operating costs.
- Colder water in the same chilled-water coil may provide better dehumidification.
- Colder water can be used to increase the capacity of an existing chilled-water distribution system. In some instances, this can save significant capital expenditures to add capacity to large central plants that have reached their flow limits.

Some system designers hesitate to use lower chilled-water temperatures, concerned that the chiller will become less efficient. As discussed in “Effect of chilled-water temperature” on page 3:

- Lower chilled-water temperature makes the chiller work harder. However, while the lower water temperature increases chiller energy consumption, it significantly reduces the chilled-water flow rate and pump energy. This combination often lowers system energy consumption.
- Lower chilled-water temperatures may require more insulation on piping to prevent unwanted condensation (“sweating”). Ensure that pipes are properly insulated at all water temperatures. Lower temperature water often does not require more insulation.

Condenser-Water Temperatures

Today’s chillers can run at various entering condenser-water temperatures, from design temperature to the lowest-allowable temperature for that particular chiller design. However, many existing older chillers are limited in their allowable condenser-water temperatures. Contact the chiller manufacturer for these limits. Optimal condenser-water temperature control is discussed in the section, “System Controls” on page 87.

Chilled- and Condenser-Water Flow Rates

The selection of chilled-water and condenser-water flow rates is a powerful tool that designers have at their disposal. Kelly and Chan¹⁰, and Schwedler and Nordeen¹¹, found that reducing flow rates can reduce the costs of chilled-water system installation and/or operation. The ASHRAE GreenGuide⁸ states, “Reducing chilled- and condenser-water flow rates (conversely, increasing the ΔT s) can not only reduce operating cost, but, more important, can free funds from being applied to the less efficient infrastructure and allow them to be applied toward increasing overall efficiency elsewhere.”

Standard rating flow conditions

Presently, the standard-rating-condition flow rates for electric chillers in ARI 550/590 are:

- 2.4 gpm/ton [0.043 L/s/kW] for evaporator
- 3.0 gpm/ton [0.054 L/s/kW] for condenser

This evaporator flow rate corresponds to a 10°F [5.6°C] temperature difference. Depending on the compressor efficiency, the corresponding condenser temperature difference is 9.1°F to 10°F [5.1°C to 5.6°C].

Absorption chillers are rated using ARI Standard 560–2000, *Absorption Water Chiller and Water Heating Packages*⁹. The evaporator flow rates are the same as those used in ARI 550/590; however, condenser (often called cooling water) flow rates differ depending on the absorption chiller design. Table 3 shows the standard rating conditions for various absorption chillers.

Table 3. Standard rating conditions for absorption chillers

Absorption Chiller Type	Condenser Flow Rate		
	gpm/ton	L/s/kW	
Single Effect	3.60	0.065	
Double Effect	Steam or hot water	4.00	0.072
	Direct fired	4.00	0.081

Selecting flow rates

Designers may use the standard *rating* conditions to compare manufacturers' performances at exactly the same conditions. However, these standards allow any flow rates to be used and certified comparisons to be made at a wider range of conditions.

For a given load, as flow rate decreases, the temperature differential increases. Table 4 reflects a 450-ton [1,580-kW refrigeration] chilled-water system, both as a base case and with low flow.

Chilled Water System		Base Case	Low Flow
Evaporator flow rate, gpm [L/s]		1,080 [68.1]	675 [42.6]
Chilled water temperature °F [°C]	Entering	54.0 [12.2]	57.0 [13.9]
	Leaving	44.0 [6.7]	41.0 [5.0]
Condenser flow rate, gpm [L/s]		1,350 [85.2]	900 [56.8]
Condenser water temperature °F [°C]	Entering	85.0 [29.4]	85.0 [29.4]
	Leaving	94.3 [34.6]	99.1 [37.3]
Chiller power, kW		256.0	292.0

In this example, notice that the leaving chilled-water temperature decreases and the leaving condenser-water temperature increases. This means that the chiller's compressor must provide more lift and use more power. At first glance, the design team may decide the chiller power difference is too large to be overcome by ancillary equipment savings. The key question is, How does this impact system energy consumption? Using the following assumptions, we can calculate system energy usage:

- 80 feet of water [239 kPa] pressure drop through chilled-water piping
- 30 feet of water [89.7 kPa] pressure drop through condenser-water piping
- 78°F [25.6°C] design wet bulb
- 93 percent motor efficiency for pumps and tower
- 75 percent pump efficiency
- Identical pipe size in chilled- and condenser-water loops (either a design decision, or indicating changing flows in an existing system)

The pressure drop through the chiller will decrease due to the lower flow rates. When using the same size pipe, the pressure drop falls by nearly the square of the decreased flow rate. While this is true for straight piping, the pressure drop does not follow this exact relationship for control valves or branches serving loads of varying diversity.

Be sure to calculate the actual pressure drop throughout the system. Hazen–Williams and Darcy–Weisbach calculate the change is to the 1.85 and

System Design Options

1.90 power, respectively. The examples here use the more conservative 1.85 power:

$$DP2/DP1 = (Flow2)/(Flow1)^{1.85}$$

Given different flow rates and entering water temperatures, a different cooling tower can be selected for the low-flow condition (Table 6):

Table 5. Low-flow conditions for chilled-water pump

	Base Case	Low Flow*
Flow rate, gpm [L/s]	1,080 [68.1]	675 [42.6]
System pressure drop, ft water [kPa]	80.0 [239]	33.5 [100]
Evaporator-bundle pressure drop, ft water [kPa]	29.7 [88.8]	12.6 [37.7]
Pump power output, hp [kW]	39.9 [29.8]	10.5 [7.80]
Pump electrical power input, kW	32.0	8.4

Table 6. Low-flow conditions for cooling tower

	Base Case	Low Flow*
Flow rate, gpm [L/s]	1,350 [85.2]	900 [56.8]
Static head, ft water [kPa]	19.1 [57.1]	12.6 [37.7]
Tower fan power output, hp [kW]	30.0 [22.4]	20.0 [14.9]
Tower fan electrical power input, kW	24.1	16.0

Table 7. Low-flow conditions for condenser-water pump

	Base Case	Low Flow*
Flow rate, gpm [L/s]	1,350 [85.2]	900 [56.8]
System pressure drop, ft water [kPa]	30 [89.7]	14.2 [42.5]
Condenser-bundle pressure drop, ft water [kPa]	19.9 [59.5]	9.6 [28.7]
Tower static lift, ft water [kPa]	19.1 [57.1]	12.6 [37.7]
Pump power output, hp [kW]	31.4 [23.4]	11.0 [8.2]
Pump electrical input, kW	25.2	8.8

* Low-flow conditions represented in Table 5 through Table 8 are 1.5 gpm/ton [0.027 L/s/kW] chilled water and 2.0 gpm/ton [0.036 L/s/kW] condenser water.

The total system power is now as follows:

Component Power (kW)	Base Case	Low Flow*
Chiller	256.0	292.0
Chilled-water pump	32.0	8.4
Condenser-water pump	25.2	8.8
Cooling tower	24.1	16.0
Total power for chilled-water system	337.3	325.2

* Low-flow conditions represented in Table 5 through Table 8 are 1.5 gpm/ton [0.027 L/s/kW] chilled water and 2.0 gpm/ton [0.036 L/s/kW] condenser water.

Figure 20. System summary at full load

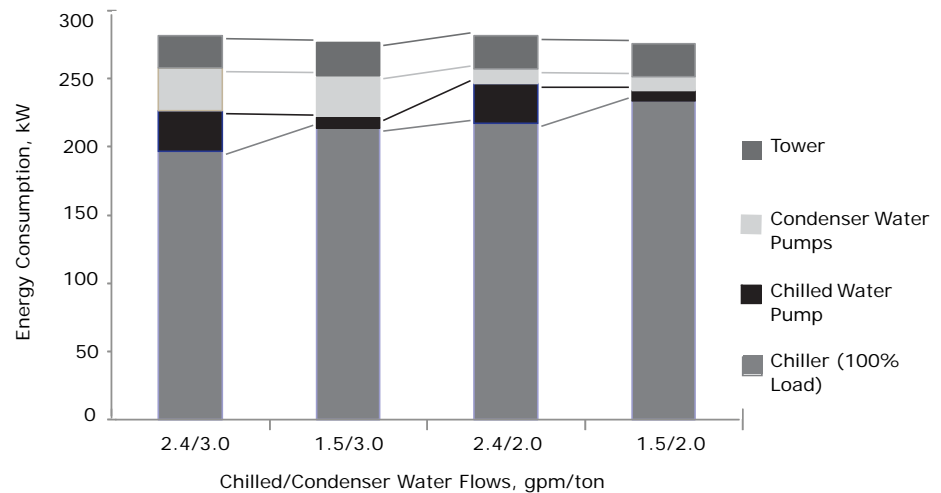

It becomes clear that flow rates can affect full-load system power (Figure 20). Even though the chiller requires more power in the low-flow system, the power reductions experienced by the pumps and cooling tower result in an overall savings for the system.

What happens at part-load conditions? Figure 21 shows the part-load performance based on the following assumptions:

- The chilled-water pump includes a variable-frequency drive.
- The condenser-water pump remains at constant power.
- The cooling tower is controlled to produce water temperatures lower than design.

Figure 21. Chilled water system performance at part load

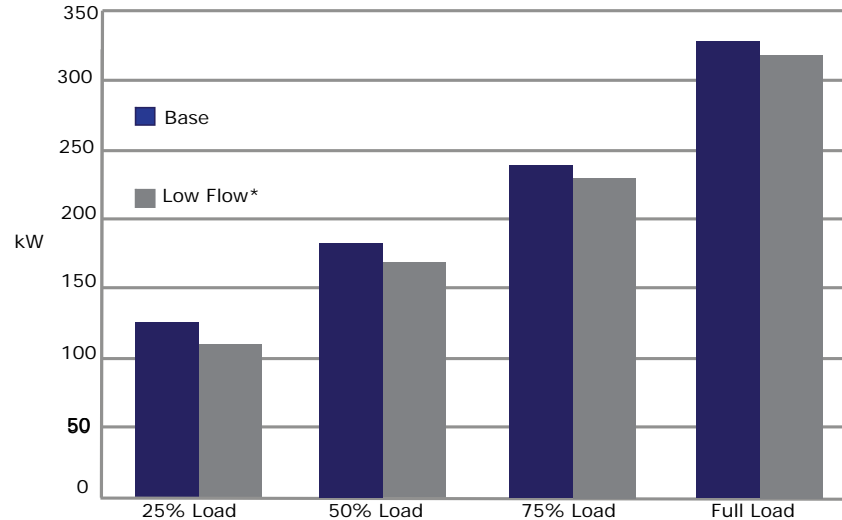

* Low-flow conditions in Figure 21 are 1.5 gpm/ton [0.027 L/s/kW] chilled water and 2.0 gpm/ton [0.036 L/s/kW] condenser water.

While the magnitude of the benefit of low-flow changes depends on the chiller type used (centrifugal, absorption, helical-rotary, scroll), all chilled-water systems can benefit from judicious use of reduced flow rates as recommended by the ASHRAE GreenGuide⁸.

Coil response to decreased entering water temperature

If coil performance data is not available from the original manufacturer, its performance could be approximated using current selection programs and known details about the coil, such as fins per foot, number of rows, tube diameter, etc. Some designers use the following approximation instead. For each 1.5 to 2.5°F [0.8°C to 1.4°C] the water temperature entering the coil is reduced, the coil returns the water 1°F [0.6°C] warmer and gives approximately the same sensible and total capacities. This is a rough approximation and a coil's actual performance depends on its design.

A coil is a simple heat exchanger. To deliver the same sensible and latent capacity when supplied with colder water, the coil's controls respond by reducing the flow rate of the water passing through it. Because the amount of water decreases while the amount of heat exchanged remains constant, the leaving water temperature increases. Thus, by supplying colder water to the coils, a low-flow system can be applied to an existing building. In a retrofit application, it is wise to reselect the coil, using the manufacturer's selection program, at a new chilled-water temperature to ensure its performance will meet the requirements.

One possible concern of low supply-water temperatures is the ability of the valve to control flow properly at low-load conditions. A properly-sized valve with good range can work well in low-flow systems. In existing systems, valves may need to be replaced if they cannot operate with the new range of flows, but the coils do not need to be replaced.

Example of coil reselection at colder temperature/reduced flow rate

Water temperatures and flow rates are variables. They should be selected to achieve an efficient and flexible water distribution system. Consider the following example of a six-row coil in an existing air handling unit.

Table 9 shows an example of selecting a chilled-water cooling coil in a 13,000-cfm (6.1-m³/s) VAV air-handling unit. The left-hand column shows the

performance of this coil when it is selected with a 44°F [6.7°C] entering fluid temperature and a 10°F [5.6°C] fluid temperature rise (ΔT). To provide the required 525 MBh [154 kW] of cooling capacity, the coil requires 105 gpm [6.6 L/s] of water.

The right-hand column shows the performance of same coil, but in this case it is selected with 40°F [4.4°C] entering fluid and a 15.6°F [8.7°C] ΔT . To provide the equivalent capacity, the coil requires only 67.2 gpm [4.2 L/s] of water.

Table 9. Impact of supply temperature and flow rate on cooling coil selection

	“Conventional” system design	“Low flow” system design
Coil face area, ft ² [m ²]	29.01 [2.69]	29.01 [2.69]
Face velocity, fpm [m/s]	448 [2.3]	448 [2.3]
Coil rows	6 rows	6 rows
Fin spacing, fins/ft [fins/m]	85 [279]	85 [279]
Total cooling capacity, MBh [kW]	525 [154]	525 [154]
Entering fluid temperature, °F [°C]	44 [6.7]	40 [4.4]
Leaving fluid temperature, °F [°C]	54 [12.2]	55.6 [13.1]
Fluid ΔT, °F [°C]	10 [5.6]	15.6 [8.7]
Fluid flow rate, gpm [L/s]	105 [6.6]	67.2 [4.2]
Fluid pressure drop, ft H ₂ O [kPa]	14.0 [41.8]	6.3 [18.8]

By lowering the entering fluid temperature, this coil can deliver the same cooling capacity with 36% less flow, at less than half of the fluid pressure drop, with no impact on the airside system.

Cooling-tower options with low flow

Smaller tower

Like coils, cooling towers are heat exchangers—although often misunderstood heat exchangers. The tower exchanges heat between the entering (warmest) water temperature and the ambient wet-bulb temperature. Therefore, in a new system or when a cooling tower is replaced, a low-flow system design allows a smaller, more efficient cooling tower to be selected. How is this possible?

Keep in mind that a cooling tower is not limited to a specific tonnage. A cooling tower is a heat exchanger that exchanges heat between the entering water temperature and the ambient wet bulb. By varying the flow or the temperature, the tower capacity can be changed—often increased.

Since the amount of heat to be rejected, Q , is approximately the same in standard-rating-condition and low-flow systems, we can estimate the heat exchange area necessary to reject the heat:

$Q = U \times A_1 \times \Delta T_1$, where
A = area,
U = coefficient of heat transfer, and
 ΔT = temperature difference

so, for a roughly equivalent heat rejection,

$$U \times A_1 \times \Delta T_1 = U \times A_2 \times \Delta T_2$$

and for a constant coefficient of heat transfer,

$$A_1 \times \Delta T_1 = A_2 \times \Delta T_2$$

Using standard rating conditions, the temperature difference between tower entering temperature and ambient wet bulb, ΔT_1 is

$$\Delta T_1 = 94.2 - 78 = 16.2^\circ\text{F} \text{ or } [34.6 - 25.6 = 9.0^\circ\text{C}]$$

while at typical low-flow conditions, ΔT_2 is

$$\Delta T_2 = 99.1 - 78 = 21.1^\circ\text{F} \text{ or } [37.3 - 25.6 = 11.7^\circ\text{C}]$$

Therefore:

$$A_1 \times 16.2 = A_2 \times 21.1 \text{ or } A_2 = 0.77 A_1$$

So, the tower would theoretically need only 77% of the heat exchange area to achieve the same heat rejection capacity, simply by reducing the flow rate from 3.0 gpm/ton [0.054 L/s/kW] to 2.0 gpm/ton [0.036 L/s/kW].

The heat exchange capacity can be altered by changing the surface area or airflow, or some combination of the two. A cooling-tower manufacturer's selection program can give the exact size and power requirements. In the example previously summarized on pages 30-32, both the cooling-tower size and airflow (hence, required fan power) were reduced.

Same tower, smaller approach

Another option is to use the same cooling tower at a lower flow rate. In a new system, this is a design decision, but in an existing system, it is often a constraint that the tower cannot be changed. Given the same heat-rejection load, the low-flow system allows the cooling tower to return colder water; that is, the tower's approach to the ambient wet-bulb temperature decreases. In the previous example of 450 tons [1580 kW], the same cooling tower would have resulted in a leaving tower-water temperature of 83.5°F [28.6°C] instead of the 85°F [29.4°C] with the smaller cooling tower. It is important to realize that the entering temperature for the tower would be approximately 97.6°F [36.4°C]. Therefore, the effect of reduced flow rate on chiller energy consumption is partially offset by the lower leaving tower-water temperature. The system would use less pump energy at the lower flow conditions.

Table 10. Same tower, smaller approach

		Present	Same tower, smaller approach
Capacity, tons [kW refrigeration]		450 [1,580]	450 [1,580]
Cooling tower	Approach, °F [°C]	7 [3.8]	5.5 [3]
	Flow rate, gpm [L/s]	1350 [85.2]	900 [56.8]
	Entering temperature, °F [°C]	94.3 [34.6]	97.6 [36.4]
	Leaving temperature, °F [°C]	85 [29.4]	83.5 [28.6]
Ambient wet-bulb temperature, °F [°C]		78 [25.6]	78 [25.6]

Same tower, larger chiller

One retrofit option that benefits many building owners is installing a new, larger chiller selected for a lower flow rating and re-using the existing cooling tower, condenser-water pump, and condenser-water pipes. In many cases, this allows the building owner to increase the chilled-water-system capacity for an expansion, with a limited budget. An example can easily demonstrate this.

A hospital presently has a 450-ton [1,580-kW refrigeration] chiller that needs to be replaced. The condenser water flow is 1,350 gpm [85.2 L/s]. The present cooling-tower selection conditions are summarized in Table 11. Recently, the cooling-tower fill was replaced. The tower, condenser water piping, and pump are in good condition. The hospital is planning an addition with 50 percent more load for a total of 675 tons [2,370 kW]. Must the hospital replace the condenser water system? The answer is “no,” as long as the chiller is selected properly.

How is this possible? As long as the new chiller’s condenser-water pressure drop is at or below that of the present chiller, the same amount of water can still be pumped. With the same flow rate, a 675-ton [2,370-kW] chiller may be selected with a condenser-water-temperature rise of approximately 15°F [8.3°C]. Using the cooling-tower manufacturer’s selection software, the same cooling tower can be selected at the elevated temperature difference. As shown in Figure 22, the new selection point will be:

- entering water temperature: 103°F [39.4°C]
- leaving water temperature: 88°F [31.1°C]
- ambient wet bulb: 78°F [25.6°C]

Table 11. Retrofit capacity changes

		Present	Larger chiller, same tower
Capacity, tons [kW refrigeration]		450 [1,580]	675 [2,370]
Cooling tower	Flow rate, gpm [L/s]	1350 [85.2]	1,350 [85.2]
	Entering temperature, °F [°C]	94.3 [34.6]	103 [39.4]
	Leaving temperature, °F [°C]	85 [29.4]	88 [31.1]
Ambient wet-bulb temperature, °F [°C]		78 [25.6]	78 [25.6]

It quickly becomes evident that the same cooling tower and flow rate are adequate to reject more heat—in this case, approximately 50 percent more heat.

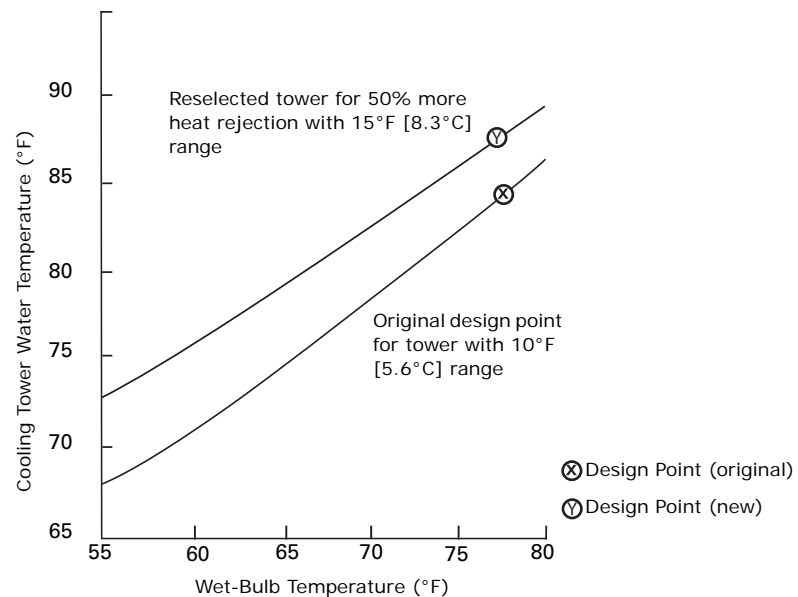
Figure 22. Cooling tower re-selection with different chiller capacities

Retrofit opportunities

The low-flow concepts for chilled- and condenser-water just described in pages 33 through 37 present tremendous retrofit opportunities. Building owners may need to increase the capacity of an existing system, for example, in response to a building addition. In many of these buildings, the condenser water system (piping, pump, and tower) is in good condition, but is considered to be too small. Or, the system has expanded but the chilled water pipes and/or coils cannot be changed. By changing from traditional design conditions, the existing infrastructure can often be used while providing additional capacity.

In both cases, either reusing an existing tower, or reusing existing chilled water piping, the design engineer can often help reduce total project costs using the existing infrastructure by selecting a chiller with a higher temperature differential.

Cost Implications

Several considerations should be kept in mind when determining sizes for new systems. As pipe size is decreased, so are valve and specialty sizes and costs. Remember that reducing pipe size increases pressure drop. Keep a balance between first cost and operating costs. This can significantly reduce the system retrofit costs because existing pipes may be used.

By reducing either chilled- or condenser-water flow rates, the following installed-cost reductions are possible:

- Reduced size of pumps, valves, strainers, fittings, and electrical connections
- In new systems, reduced pipe sizes
- In existing systems, more capacity from existing chilled-water piping
- Reduced cooling-tower size, footprint, and fan power

If a physically-smaller cooling tower is selected using low flow, its reduced footprint can benefit building owners in a number of ways:

- Reduced real estate requirements (often more important than realized)
- Reduced structural requirement, since the amount of tower water is reduced
- Reduced excavation and material costs in the case of a large, built-up tower with a concrete sump
- Improved aesthetics because of the reduced tower height

In addition to reducing installation costs, operating cost reductions for the whole system are also available. Due to a smaller pump and/or tower, the pump and tower operating costs can be reduced substantially with less adverse impact on the chiller operating cost. Analysis programs such as EnergyPlus, eQuest, TRACE[™], or System Analyzer[™] software can be used to determine annual operating costs. Nordeen and Schwedler¹¹ showed that operating costs for chilled-water systems using absorption chillers can benefit greatly from reduced condenser-water flow. Figure 23 shows operating costs as generated with System Analyzer analysis software.

Figure 23. Annual system operating costs (absorption chillers)

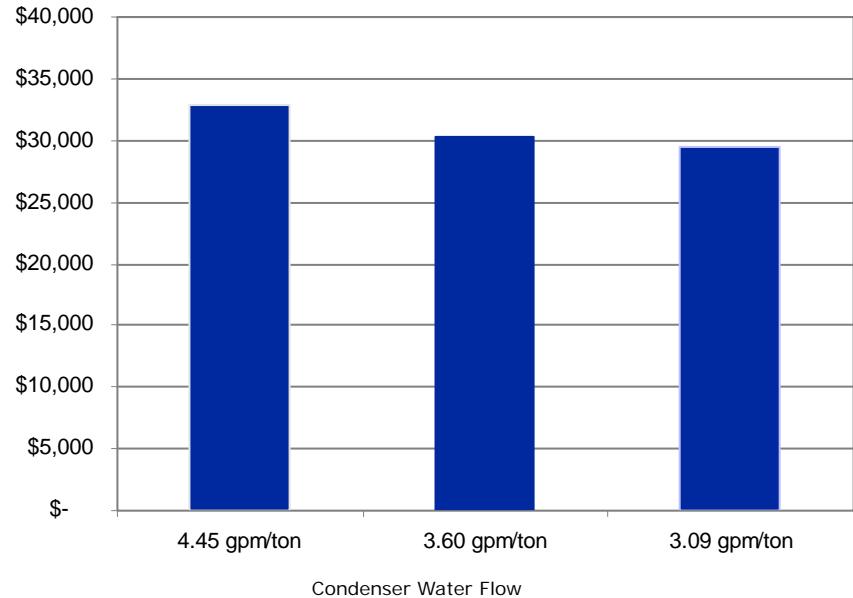

Kelly and Chan¹⁰ compare the operational costs of chilled-water system designs in site locations. Their summary states:

In conclusion, there are times you can ‘have your cake and eat it too.’ In most cases, larger ΔT s and the associated lower flow rates will not only save installation cost but will usually save energy over the course of the year. This is especially true if a portion of the first cost savings is reinvested in more efficient chillers. With the same cost chillers, at worst, the annual operating cost with the lower flows will be about equal to “standard” flows but still at a lower first cost.

Misconceptions about Low-Flow Rates

Some common misconceptions about low-flow systems include:

- 1 Low flow is only good for long piping runs
- 2 Low flow only works well for specific manufacturers’ chillers
- 3 Low flow can only be applied to new chilled-water systems

Let’s discuss each of these three misconceptions.

Misconception 1—Low flow is only good for long piping runs.

One way to examine this claim is to use our previous example, but to concentrate on the condenser-water side. We’ll start with the example covered on pages 30-32. Using the same chiller, but a smaller cooling tower

and a more conservative zero condenser-water-pipe pressure drop, we can examine the effect of reducing flow rates.

Table 12. Reduced flow-rate effect

Condenser Water Pump	Base Case	Low Flow
Flow rate, gpm [L/s]	1350 [85.2]	900 [56.8]
System pressure drop, ft water [kPa]	0	0
Condenser bundle pressure drop, ft water [kPa]	19.9 [59.5]	9.6 [28.7]
Tower static lift, ft water [kPa]	19.1 [57.1]	12.6 [37.7]
Pump power output, hp [kW]	17.7 [13.2]	6.7 [5.0]
Pump fan electrical input, kW	14.2	5.4

Figure 24. System energy consumption (no pipes)

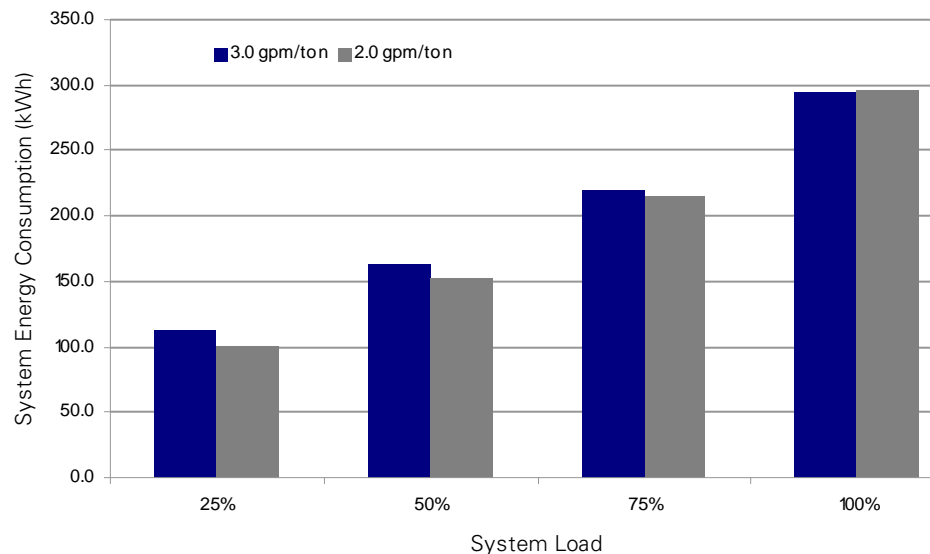

Energy consumption for the chiller, condenser-water pump, and cooling-tower fans is shown in Figure 24. Note that only at full load does the total power of the chilled-water *plant* increase. Recall that this is with absolutely **no** pressure drop through the condenser-water piping, valves, or fittings. It is interesting to note that the break-even point at full load is approximately 8 feet of head (water) [23.9 kPa]. Also note that at all part-load conditions, the total power of the low-flow system is less than that of the base system. It is easy to see that even for short piping runs, reducing flow rates can improve plant energy consumption.

Misconception 2—Low flow only works for specific manufacturers' chillers.

Demirchian and Maragareci¹², Eley¹³, and Schwedler and Nordeen¹¹ independently showed that system energy consumption can be reduced by reducing flow rates. It is interesting to note that in the systems studied, three different chiller manufacturer's chillers were examined, yet the energy savings only varied from 2.0 to 6.5 percent. In all cases, regardless of which manufacturer's chillers were used, the system energy consumption was reduced. In addition, Demirchian and Maragareci¹², and Schwedler and Nordeen¹¹ also noted reduced first costs.

Misconception 3—Low flow can only be applied to new chilled-water systems.

As previously discussed in "Coil response to decreased entering water temperature" on page 33 and "Cooling-tower options with low flow" on page 34, there are distinct opportunities to use existing infrastructure (pumps, pipes, coils, and cooling towers) to either expand available cooling capacity and/or reduce system energy costs by using lower flow rates. Upon examination, it is clear that low-flow systems allow savings even on short piping runs, work with all manufacturers' chillers, and can be used in retrofit applications. As a designer, remember to review the benefits to the building owner. Often, reducing flow rates can provide significant value.

Consulting engineers, utilities, and ASHRAE have all concluded that reducing chilled- and condenser-water flow rates (conversely, increasing the ΔT s) reduces both installed and operating costs. It is important to reduce chilled- and condenser-water system flow rates to provide optimal designs to building owners and operators.

System Configurations

Multiple chilled-water systems are more common than single chilled-water systems for the same reason that most commercial airplanes have more than one engine—the balance of reliability and cost. The most typical system configuration, by far, has two chillers. Since system loads can vary throughout a wide spectrum, multiple chilled-water systems can often operate with one chiller. During these periods, if the system is designed properly, the energy required to operate a second chiller and its auxiliaries can be conserved.

This section examines:

- Constant flow systems
- Systems in which flow is constant through chillers, but variable through the rest of the system
- Systems in which flow varies throughout the entire system—including the chillers

Parallel Chillers

Figure 25 shows a system with two chillers piped in parallel, using a single chilled-water pump.

Figure 25. Parallel chillers with a single, common chiller pump

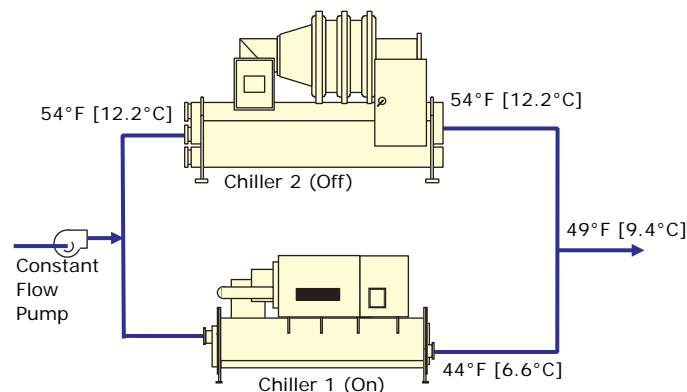

With constant flow loads, water flows in both chillers continually, whether the chiller is operating or not. Clearly, this can disrupt the supply chilled-water temperature when only one chiller is operating. The temperatures indicated in Figure 25 show how the supply water temperature rises when one chiller is cycled off in response to a part-load condition. This may result in inadequate dehumidification capabilities or the inability to satisfy specific loads.

Alternatively, the operating chiller can be reset to produce a lower supply temperature at this condition. In this way, the mixed system supply-water temperature may be maintained at a more acceptable temperature. This complicates the control system and presents the possibility of increasing chiller energy consumption due to the requirement for lower-temperature water. There will also be a low limit to this water temperature, dependent on the chiller's low pressure cut-out control, low evaporator-refrigerant-temperature limits, or low leaving chilled-water limits. The more chillers in the system, the worse the problem becomes. For this reason, this configuration is seldom used in systems with more than two chillers.

Additionally, ASHRAE/IESNA Standard 90.1–2007 (Section 6.5.4.2) prohibits this type of system when the pump is larger than 10 hp [7.5 kW]. The standard requires that, in systems that contain more than one chiller piped in parallel, system water flow must be reduced when a chiller is not operating.

Figure 26. Parallel chillers with separate, dedicated chiller pumps

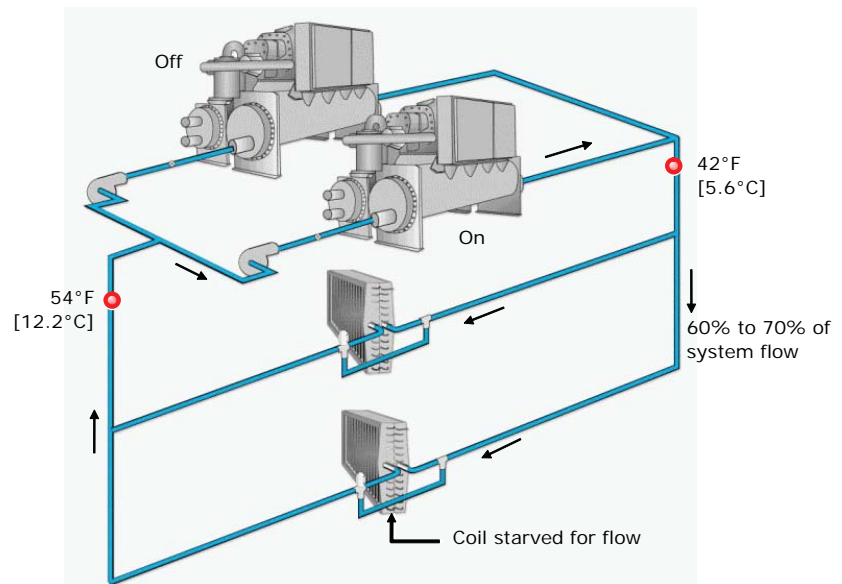

If separate, dedicated chiller pumps are used (Figure 26), a chiller–pump pair can be cycled together. This solves the flow mixing problem described above, but presents a new problem. Below 50-percent load, only one chiller and one pump are operating. The total water flow in the system decreases significantly, typically 60 to 70 percent of full system flow, according to the pump–system curve relationship.

Ideally, at this part-load flow rate, all of the coils will receive less water, regardless of their actual need. Typically, however, some coils receive full water flow and others receive little or no water. In either case, heavily-loaded coils or the loads farthest from the pump will usually be “starved” for flow. Examples of spaces with constant heavy loads that may suffer include computer rooms, conference rooms, photocopy rooms, and rooms with high solar loads.

Series Chillers

If chillers are piped in series, as in Figure 27, the mixing problem disappears and the starving coils problem (when one of the pumps in a parallel arrangement is not running) is resolved. Series flow presents a new set of temperature and flow control challenges.

Figure 27. Series chillers

System ΔT greater than 14°F

One reason series chilled-water systems should be designed using at least a 14 degree ΔT is because a lower ΔT ignores the opportunity for lower flow rates and reduced pump energy. For small, packaged chillers, a reason to have at least a 14 degree ΔT is to avoid exceeding the chiller's maximum flow rate. The system will more likely experience evaporator flow limit maximums if the ΔT is too low.

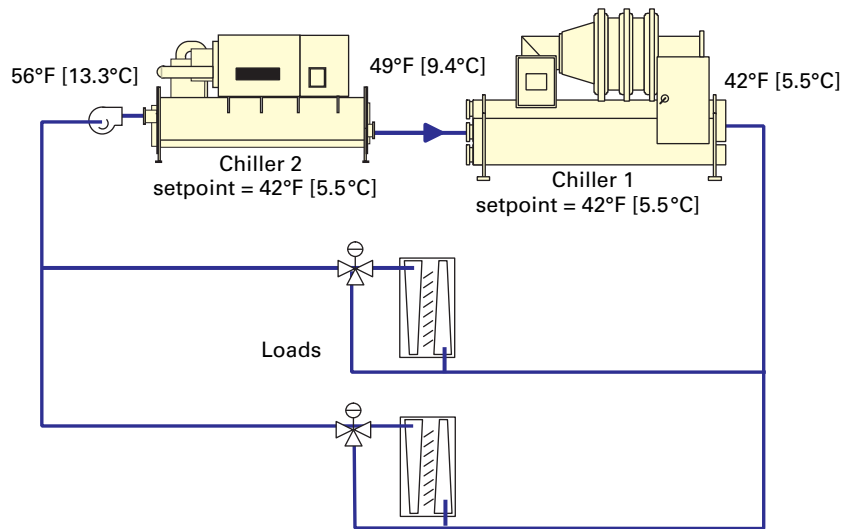

The flow rate through each chiller is the entire system flow, that is, double the individual flow rate of two parallel chillers. This means that the chiller evaporator must accommodate the doubled water quantity. This may be accommodated by using fewer water passes in the evaporator, which may result in decreased chiller efficiency.

However, this efficiency loss due to fewer passes is more than offset by the increased efficiency of the upstream chiller, now operating at a warmer temperature.

Pressure losses are additive when the chillers are piped in series. This increases total system pressure drop, thereby using more pump energy. On the other hand, series chillers work particularly well in low-flow systems, where the system temperature difference is greater than 14°F [7.8°C], resulting in less pressure drop.

Low-flow systems were discussed in detail in "Selecting flow rates" on page 30. Series chillers are also suited to variable flow systems, where the operating pressure drop is reduced. Variable flow is discussed beginning on page 55.

Temperature control can be executed in several ways. Figure 27 shows a strategy where the controller on each chiller is set at the system design setpoint. Either chiller can be used to meet the system demand for up to 50

percent of the system load. At system loads greater than 50 percent, the upstream chiller is preferentially loaded because it will attempt to produce the design leaving chilled-water temperature. Any portion of the load that remains is directed to the downstream chiller.

If chiller setpoints are staggered (upstream at 49°F [9.4°C] and downstream at 42°F [5.5°C]), the downstream chiller is loaded first. The upstream machine then meets any portion of the system load that the downstream chiller cannot meet. This control strategy offers several benefits. The first is that the upstream chiller is always operating at an elevated temperature. This allows it to operate at a higher efficiency. Also, placing an absorption chiller in the upstream position increases its capacity. As an example, an absorption chiller that can produce 500 tons [1,760 kW] at a leaving chilled-water temperature of 44°F [6.6°C] may produce 600 tons [2,110 kW] at 50°F [10°C]. Centrifugal, helical-rotary, reciprocating, and scroll chillers experience capacity and efficiency changes to a lesser degree. By judicious use of the series configuration, these benefits can provide reduced installed cost and fuel flexibility to the building owner. While not shown, a single manual bypass with proper valving can provide for servicing of chillers.

Equal loading of the two chillers may be accomplished by using a chiller plant management system to dynamically reset the upstream chiller's setpoint in response to changes in system load.

Primary–Secondary (Decoupled) Systems

The root cause of the difficulties with parallel chiller control in a constant volume system is the fixed relationship between chiller- and system-flow rates. If, instead, we can hydraulically decouple the production (chiller) piping from the distribution (load) piping, it is possible to control them separately. The fixed relationships are then broken apart. The production pumps are typically constant volume, while the distribution pumps are variable volume.

Hydraulic decoupling

Figure 28 shows the basic decoupled system. This strategy is also referred to as a primary–secondary pumping arrangement. Separate pumps are dedicated to production and distribution. While the same water is pumped twice (by different pumps), there is no duplication of pumping energy. This is because the production pumps overcome only the chiller and production-side pressure drop while the distribution pumps overcome only the distribution system pressure drop.

Check valves

Some designers recommend the installation of a check valve in the bypass line of a primary–secondary system to eliminate the possibility of deficit flow in the bypass line. The premise is that if there is a system problem (low temperature differential), the check valve will put the primary and secondary pumps in series and pump more water through the chiller, thus balancing the primary and secondary flow requirements. This is not universally accepted.

Coad¹⁴ states:

One constraint is that if the system is designed as variable flow and is experiencing operating problems related to low return water temperatures, the solution is *not* in the plant but rather in the load.

and

One solution that has been suggested is to install a check valve in the plant common pipe or decoupling line circuit ... However, to be realistic, all that the check valve can do is assure that no water bypasses the chillers, which in turn has the effect of increasing flow in the chiller. Thus with the installation of the check valve must be an algorithm to either slow down system pump(s) when flow increases beyond the design maximum for the on chiller or turn on additional chillers. Thus the check valve solution offers its own problems and many designers feel very uncomfortable with forcing pumps into series operation without the benefit of understanding the full impact thereof.

This manual does *not* recommend the use of check valves in the bypass line.

Figure 28. Decoupled arrangement

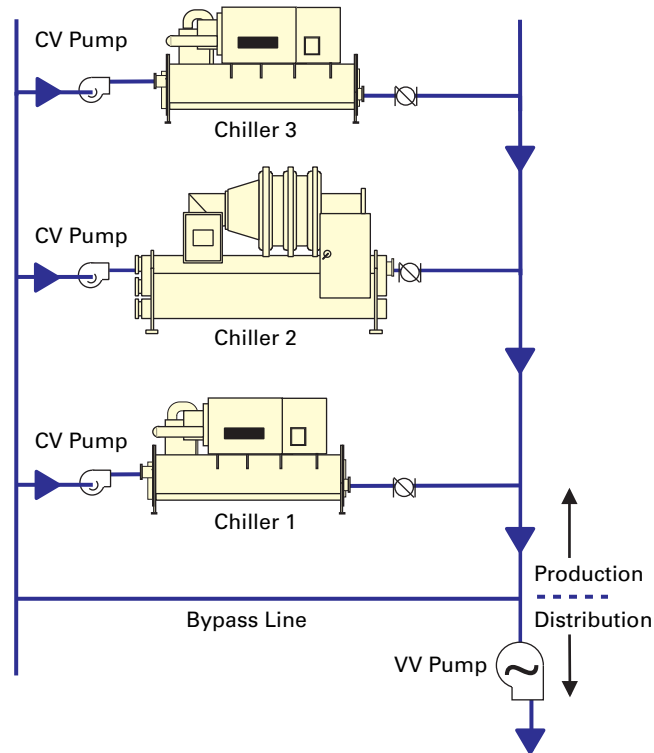

The unrestricted bypass line hydraulically decouples, or separates, the production and distribution pumps so that they cannot operate in a series coupled pumping arrangement.

Although the two pumping systems are independent, they have three things in common:

- bypass piping,
- no-flow static head (from the building water column), and
- water.

Changes in flows or pressures, due to variations in dynamic head or the number of chillers operating, cannot cross the bypass line.

The extent of decoupling depends solely on the restriction (or lack of restriction) in the bypass pipe. Total decoupling is accomplished only if the bypass piping has zero pressure loss at any flow. Since this is not possible, some insignificant pump coupling will exist. The important issue is to keep the bypass piping free of unnecessary restrictions such as check valves (see sidebar).

Production

An individual production (chiller) pump need only pump water from the return bypass tee (point A in Figure 29), through its chiller, and into the tee at the supply-end of the bypass line (point B in Figure 29). This represents a relatively small pressure differential and a low pumping-power requirement. In addition, each individual pump operates only when its corresponding chiller runs. Production loops are independent of one another, as well as from the distribution loop. They may consist of pump–chiller pairs that act as independent chillers. Or, manifolded and stepped pumps can be teamed with automatic, two-position chiller valves to operate in the same way as pump–chiller pairs. Figure 29 shows the latter arrangement. Temperature control is also independent. The conventional chilled-water temperature controller furnished with the chiller serves this function.

Figure 29. Production loop

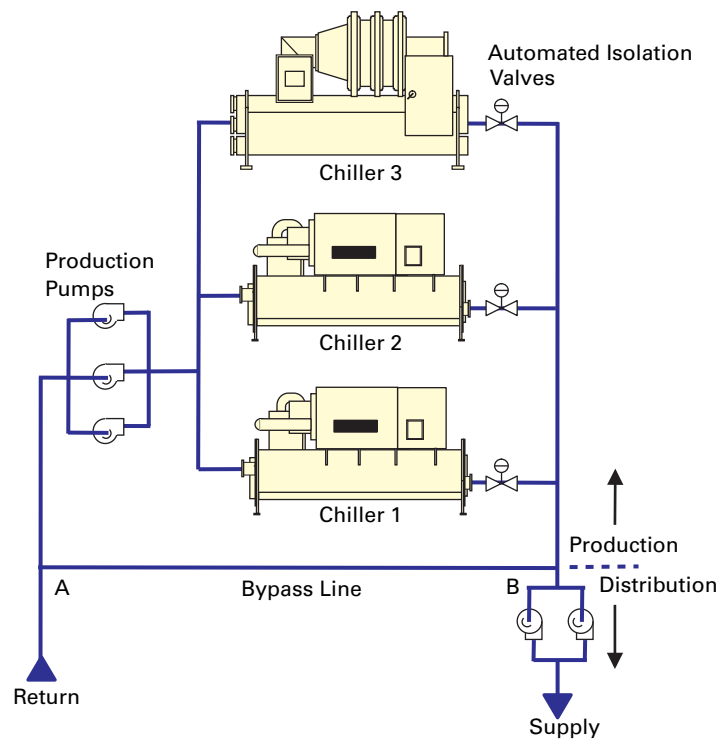

Chillers may be of any type, age, size, or manufacturer. System operation is simplest, however, if all of the chillers are designed to operate with the same leaving chilled-water temperature and through the same system temperature rise (temperature difference) across the chiller.

Note: If the chillers in a decoupled system make the same chilled-water temperature, then all the operating chillers are loaded to equal percentages. There may be times when preferentially loading a chiller is desired. This is discussed in “Preferential Loading” on page 73.

Distribution

Distribution pumps take water from the supply water tee (point B in Figure 29), push it through all the distribution piping and load terminals, and then on to the return water tee (point A in Figure 29). This pump can (and should) allow variable flow.

Figure 30. Distribution loop

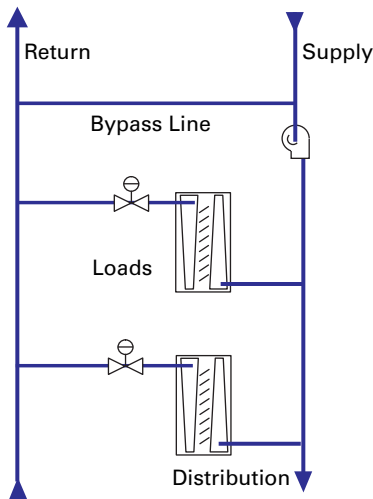

By itself, the distribution system is easy to understand. Figure 30 shows a simplified distribution system consisting of multiple cooling coils, each controlled by a valve that regulates the flow in its respective coil. In this case, the flow control valves should not be three-way because a constant flow is not desired. Instead, two-way modulating valves are used. As the aggregate loads change system flow, a constant speed pump would “ride” its flow-rate versus head-pressure relationship. This means that in response to the change of flow required, the pump will find a new equilibrium point along its operating curve (move from point A to point B in Figure 31).

Alternatively, multiple pumps or variable-speed pumps can be used to limit the dynamic pumping head, similar to VAV fan control. Properly designed, part-load pumping power can approach the theoretical cubic relationship to flow, thus reducing energy consumption significantly. Today, most decoupled systems use a variable-speed drive on the distribution pump, and it may be required by the applicable energy code.

Figure 31. Example pump curve

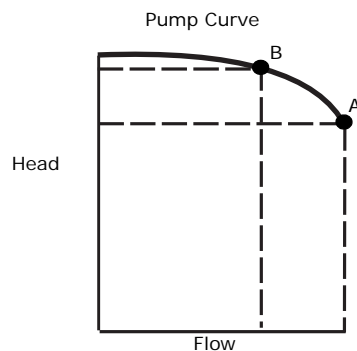

A common strategy for operating the variable speed pump is to adjust the speed of the pump’s motor to create a sufficient differential pressure, ΔP , at one or more critical points in the system, as shown in Figure 33. This pressure difference tends to decrease when the air-handler control valves open in response to increasing loads. To restore the ΔP across the system, the pump controller increases the speed of the pump. Conversely, when the air-handler control valves close in response to decreased coil loads, the pump controller slows the pump speed to maintain the target ΔP .

Distribution-loop benefits of decoupled system arrangement

The distribution system benefits from the ability to accommodate load diversity, the fact that system flow is variable, and (in a properly operating system) the fact that return water is maintained at temperatures near design. The last assumption is discussed further in “Low ΔT syndrome” on page 79.

Load diversity. Not all chilled-water loads peak simultaneously. Therefore, the quantity of water that flows at any one time is reduced from the “sum of the peaks” load that would be required in a constant-flow distribution loop. This presents the possibility of reducing chiller, pump, and pipe sizes significantly.

Variable flow. Because two-way control valves are used on the cooling coils, only the water that the loads actually use is pumped. Most of the time, this means a significantly reduced flow rate, accompanied by an even more significant reduction in pumping energy.

Elevated return-water temperatures. Because unused chilled water does not bypass the cooling coils (two-way, rather than three-way, control valves), all water that is returned accomplishes some cooling. Theoretically, the return-water temperature will always be at least as high as it is at full load. From a practical standpoint, this is not always possible, but it is closely approached in a properly operating system. In fact, at most part-load conditions, water returns from properly functioning air-conditioning coils at higher-than-design temperatures. In systems that use counterflow cooling coils, this occurs because the water leaving the coil tries to approach the temperature of the entering airstream.

Warm return water provides advantages in system design. It permits “preferential” loading of chillers, for example. Warmer return water is useful with all systems, but particularly so with heat recovery and free cooling applications. For more information, refer to “Chilled-Water System Variations” on page 70.

Pumping arrangements

Common

Various distribution system arrangements are possible. A single, large pumping station, as shown in Figure 29, can be used. The station may consist of single or multiplexed pumps sequenced on or off.

Campus

Alternatively, each of several secondary distribution systems can be piped in parallel. For example, Figure 32 shows separate distribution systems for each of three loads. Clearly, this arrangement lends itself to the possibility of plant expansion by simply adding secondary distribution pumps to the existing plant.

Figure 32. Campus pumping arrangement

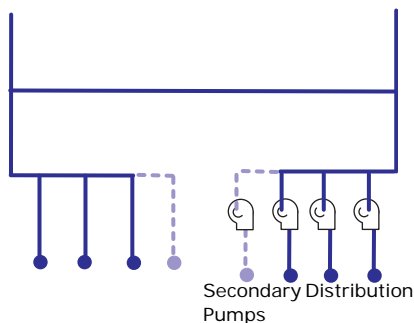

Tertiary or distributed

Tertiary pumping is an extension of primary–secondary pumping when the distribution or secondary pump must overcome diverse and severe pumping requirements.

System loads can also be decoupled from the secondary distribution system. This is frequently done with very large systems. Figure 33 shows one method of providing “tertiary pumping” at the loads. A “load” may be something as large as an entire building, or as small as an individual cooling coil. When one or more loads have extreme head requirements, the degree of range ability of the distribution pump is severely curtailed. Tertiary pumping allows the excess pumping requirements to be placed on a third pumping system thus shielding the distribution pump from divergent pressure requirements.

Most importantly, the loads must be controlled so that only the water needed to perform cooling is taken from the distribution loop. Water must not be allowed to flow into the return piping until it has sustained a specific temperature rise. Tertiary pumps can be either constant flow or variable flow, to best meet the terminal load requirements.

Figure 33. Tertiary pumping arrangement

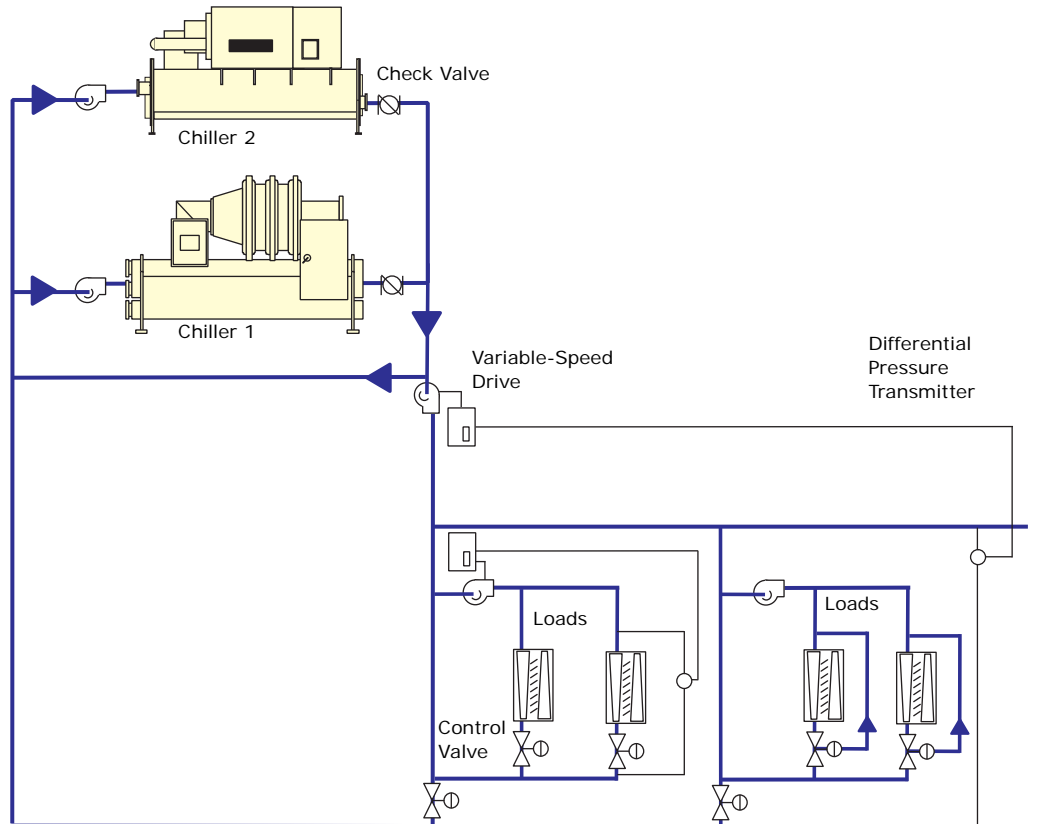

Decoupled system—principle of operation

Figure 34. Decoupled system supply tee

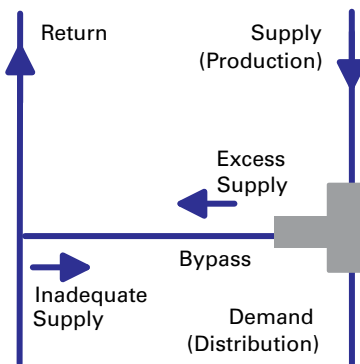

At the tee connecting the supply and bypass lines, a supply–demand relationship exists, as shown in Figure 34. Think of the total flow rate from all operating pump–chiller pairs as supply. Demand is the distribution system flow required to meet loads. Whenever supply and demand flows are unequal, water will flow into, or out of, the bypass line. Flow can be sensed directly or inferred from the bypass–water temperature.

An inadequate supply to meet demand causes return water to flow out of the bypass leg of the tee and into the distribution system. The mixture of chiller–supply water and warm system–return water, then, flows into the distribution loop. Supply–water temperature control is compromised when this happens. If the bypass–line flow into the supply tee (Figure 34) can be sensed, its presence can be used to energize another pump–chiller pair. The increase in supply water flow from the additional pump changes the supply–demand relationship at the tee, eliminating return–water mixing. As long as return–water mixing does not occur at the supply tee, no additional chiller capacity is required. When mixing does occur, an additional chiller may be needed, depending on the amount of mixing that can be tolerated.

Much of the time, supply exceeds demand and the surplus flows to the return tee. If a chiller pump is stopped prematurely, the bypass–line flow will again

show a deficit and the pump will be cycled on again. The amount of surplus flow necessary depends on the size of the chiller to be shut off. The surplus flow must exceed a certain quantity before shutting off a chiller–pump pair. If all chillers are equal in size, the surplus-flow signal can be a constant value. Control of the number of chillers is accomplished by simply noting the direction of flow in the bypass line. Thus, the system operates as a flow-based demand system, not a temperature-based demand system.

Flow-based control

To properly operate a primary–secondary system, an indication of direction of flow and the flow rate through the bypass line is necessary. This may be done either directly or indirectly. When bypass flow is from supply to return, it is called *surplus*. Bypass flow moving from return to supply is termed *deficit*.

Flow-sensing

Direct flow-sensing in the bypass line can be accomplished in several ways. A number of flow-metering technologies have been used successfully. These include Pitot tube, venturi, orifice plate, differential pressure, turbine, impeller, vortex, magnetic, and ultrasonic transit-time. The accuracy, ease of installation, maintainability, and cost of meter technologies vary widely. To give accurate results, a flow meter must be calibrated periodically, with some flow meters requiring more-frequent calibration than others. When using flow-sensing devices, it is important to understand the range of flows a device can properly measure and its calibration requirements. The readings will only be as good as the instrumentation. Also note that many flow-measurement devices require several diameters of straight pipe for accurate readings.

Temperature-sensing

Mixed water streams at the outlets of the supply- and return-water tees (Figure 35) can be used to indirectly determine the supply–demand relationship. Standard temperature-mixing equations can be used to determine the exact amount of surplus or deficit flow in the bypass line.

The five temperatures sensed—at points A, B, C, D, and E—are received by a programmable controller. (Some control systems use only two sensors, at points B and D, in conjunction with “pre-programmed” algebraic mixing equations.) Processing software applies the classic mixing equations and determines the resulting action to properly control the chilled-water system.

Note that sensor D needs to be very accurate, especially if there are many chillers, since small temperature changes may warrant chiller sequencing. Either temperature-sensing strategy has a cost and flexibility advantage if a building or chiller-plant management system already exists or is planned.

Figure 35. Temperature-sensing

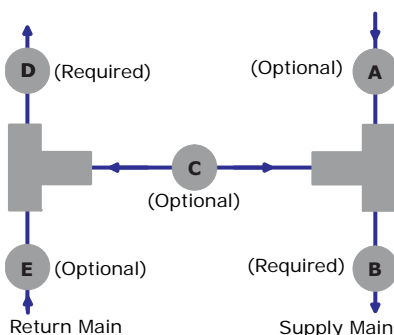

Chiller sequencing in decoupled systems

Given the amount and direction of flow in the bypass line, chillers can be added or subtracted.

Adding a chiller

When there is deficit flow in the bypass line, the system is receiving water at a temperature above the desired supply water temperature. At this point in time, a chiller and pump may be added. Many operators sense deficit flow for a particular amount of time (for example, 15 minutes) to ensure that the deficit flow is not a result of some transient condition. This reduces the chances of cycling a chiller; that is, turning on a chiller and then turning it off after a short time.

Subtracting a chiller

A chiller may be turned off when enough surplus water is flowing through the bypass line. How much is enough? Enough so that the chiller does not need to cycle on again in a short time period. Many system operators compare the amount of surplus flow with the flow rate of the chiller they are considering turning off. If this ratio is 110 to 115 percent, they turn the chiller off. Let's look at an example:

Chiller 1 can make 960 gpm [60.6 L/s] of 40°F [4.4°C] chilled-water, while Chiller 2 can make 1,440 gpm [90.8 L/s]. At present, there is 1,100 gpm [69.4 L/s] of surplus flow in the bypass line.

- The surplus bypass flow is presently 115 percent of Chiller 1's flow. If we turn Chiller 1 off, we will have 140 gpm [8.8 L/s] of surplus flow left.
- Note that the surplus bypass flow is presently only 76 percent of Chiller 2's flow. If we turn Chiller 2 off, we will have 340 gpm [21.5 L/s] of *deficit* flow. It is clear that we would have to cycle that chiller back on soon.

In this case, we could turn Chiller 1 off and leave Chiller 2 on for the most efficient use of the chillers.

Multiple chilled-water plants on a distribution loop

When decoupled systems are used on large campus-type systems, added loads are often located some distance away from the original loads. Yet, planners like the idea of somehow hooking the new loads to the existing system. The double-ended system shown in Figure 36 is one way of handling this requirement. A second production facility is placed at a convenient location in the new part of the campus. Its distribution plant is laid out as a mirror image of the original piping, and connects to it at the ends of each system. Each production facility has its own bypass.

Both production loops feed into the now common distribution loop. Depending on the flows from the production facility distribution pumps, loads could be served by either plant.

Figure 36. Double-ended decoupled system

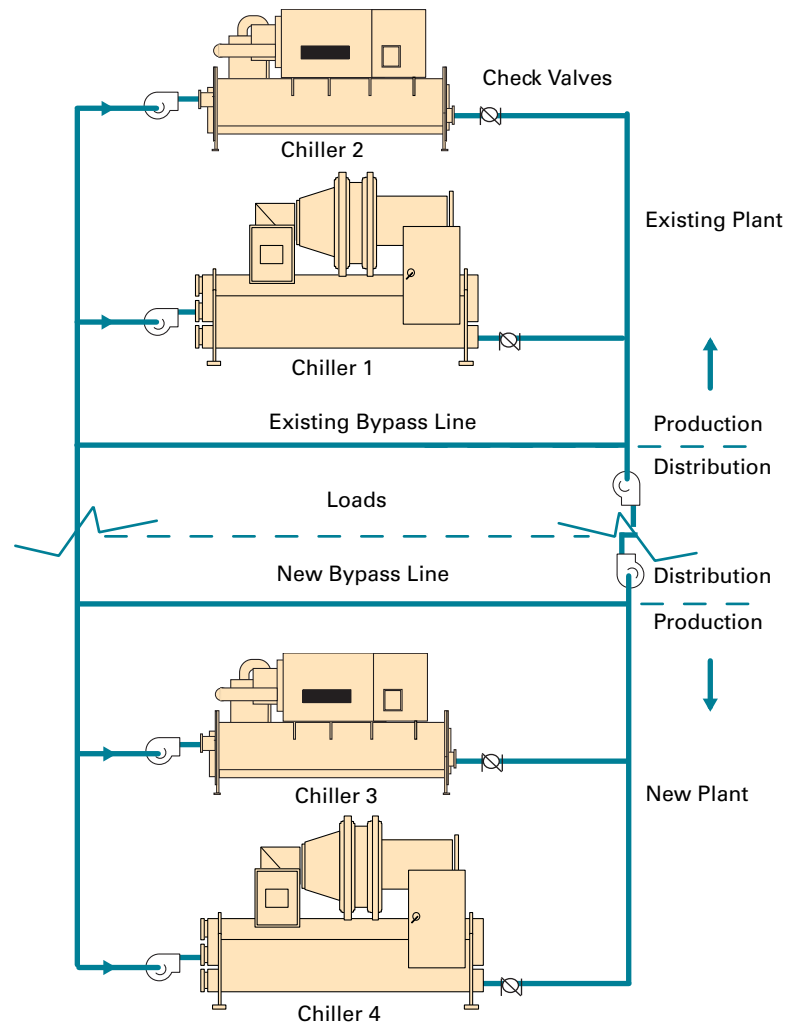

Other chiller plant/distribution loop arrangements are possible, but if used, they should be reviewed to make certain they will be free from hydronic problems.

One of the benefits of decoupled water systems is that they are simple to control. The distribution pump flow is determined by a pressure transducer located at the furthest load. Flow in the decoupler indicates when to start and stop chillers and the chiller pumps are turned on and off with the chillers. Much of this simplicity is lost when multiple chiller plants are connected to the same system. The system shown in the figure above is a fairly simple example, but even so it can be used to show the difficulty of controlling these systems. The following sections point out some of the complications.

Pump control in a double-ended decoupled system

Chiller pump control in a double-ended decoupled system remains unchanged; the chiller pump is started when the chiller is enabled. On a single-plant decoupled system, the distribution pump's speed is modulated based on a pressure sensor located at the end of the loop (point of lowest pressure) to maintain sufficient pressure drop across all the loads.

When more than one chiller plant is operating, finding the right location for the differential pressure sensor can be difficult. The point of lowest pressure in the system shifts depending on which loads are using the most water. It will probably be necessary to have a number of differential pressure sensors in the distribution loop. In that instance, the control system determines the lowest differential pressure signal and uses it to determine what speed signals to send to the distribution pumps. Sending the same speed signal to both distribution pumps is simple and will prevent the pumps from “fighting” each other for the load. However, it will likely result in more chillers operating than would be required to meet the load (more on this below). There is one exception: If only one chilled-water plant has an operating chiller, the distribution pump associated with that plant should be the only one operating.

Chiller sequencing in a double-ended decoupled system

In addition to pump control, the sequencing of chillers must be integrated between the two plants. With a double-ended plant, it is possible to have one plant operating in deficit flow and the other with sufficient surplus flow to meet the needs of the loads (load/flow imbalance). In other words, a sufficient number of chillers are operating to meet the load, but the distribution pumps are not delivering the flow to where it is needed. There are two solutions to this problem:

- 1 Adjust the speeds of the distribution pumps to move the water to where it is needed. This solution is simple in concept but difficult in application and will not be covered here. It increases complexity and should be considered carefully prior to implementation. If this is attempted, both distribution pump speeds should be changed slowly, and in opposite directions (increase one, decrease the other).
- 2 Allow each of the plants to make start/stop decisions based on the flow in its decoupler. In this case, the needs of the loads will be met; however, more chillers may be running than would otherwise be required.

Starting chillers. When deficit flow is detected at a chilled-water plant, a chiller associated with that plant should be started. This should start chillers in the plant closest to the loads using the most water and help avoid the load/flow imbalance described above. Deficit flow can be detected by either of the common flow detection methods. (See “Flow-based control” on page 51.) Note that this limits the operator's flexibility to preferentially start chillers in the plant further from the load (preferential start may be desirable to load the plant with the most efficient chillers first, for example).

Stopping chillers. On a single-plant decoupled system, surplus flow through the decoupler pipe is the normal operating mode. When the surplus flow exceeds the flow of one of the chillers in the plant by a fixed percentage, that chiller and its pump can be stopped and the plant will still be creating surplus flow. On double-ended plants this same logic can be used; however, a chiller should only be shut off when *both* plants have sufficient surplus to shut off a chiller. Only one chiller should be stopped at this time, and it should be the one in the plant with the most surplus flow. Thus, the normal operating mode for a double-ended plant is with one plant in surplus and the other operating

with a surplus that may, or may not, be large enough to indicate stopping a chiller in that plant.

Other plant designs

There are many other ways to connect chillers to distributed loops and each provides its own challenges and opportunities. The advent of variable-primary-flow chilled-water systems offers some new opportunities as does distributed pumping. In any case, getting system design advice specific to your system early in the process can prevent or identify many operational challenges.

Variable-Primary-Flow Systems

Two main physical differences distinguish this type of system from the more familiar primary–secondary design, which hydraulically “decouples” the constant-flow production side of the chilled-water loop from the variable-flow distribution side. The variable-primary-flow (VPF) design *eliminates the constant-flow chiller pumps* and uses the variable-flow pumps to circulate water throughout the entire chilled water loop (Figure 37). Both systems include a bypass line, but the VPF bypass will be smaller.

Figure 37. Variable-primary-flow system

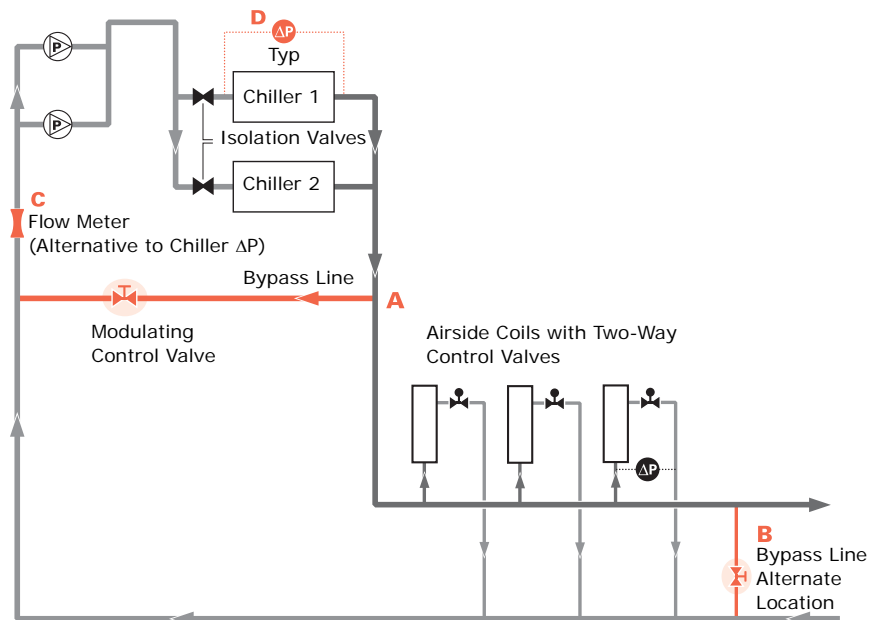

In a VPF system, **water flow varies throughout the entire system**—through the evaporator of each operating chiller as well as through the cooling coils. Two-way control valves on coils, check (or isolation) valves on chillers, and a bypass pipe with a control valve are required to implement a VPF system.

- Variable-flow chiller pumps eliminate the need for a separate distribution pump.

- The bypass can be positioned either upstream or downstream of the cooling coils.
- A control valve in the bypass ensures that the amount of flow through the operating chiller(s) never falls below the minimum limit, but remains closed most of the time.

Notice that the VPF design adds a modulating control valve in the bypass line. At low loads, the bypass valve delivers the water necessary to maintain the minimum evaporator-flow limit of each operating chiller. By contrast, the bypass line in a primary-secondary system ensures constant chiller flow at all times.

A less obvious difference between variable and constant primary flow lies in system operation. In a primary-secondary system, a chiller and its primary pump typically operate in tandem. *The VPF design can separate pump control (delivering enough water) from chiller sequencing (making the water cold enough).*

Like the secondary pump in a primary-secondary system, the pumps in a typical VPF system operate to maintain a target differential pressure, ΔP , at a specific point in the system (Figure 37). This pressure difference tends to decrease when the air-handler control valves open in response to increasing loads. To restore the ΔP across the system, the pump controller increases the speed of the pump. Conversely, when the air-handler control valves close in response to decreased coil loads, the pump controller slows the pump speed to maintain the target ΔP .

Meanwhile, the plant controller stages the chillers on and off to match cooling capacity with system load. If the air handlers operate properly, the difference between the return- and supply-water temperatures, ΔT , remains nearly constant. Therefore, increasing the water flow through the chiller evaporators increases the load on the operating chillers.

Advantages of variable primary flow

The desire to make or save money lies at the heart of many of our decisions. In the context of HVAC design, decisions made to save money often involve a trade-off between acquisition expense and operating cost. If you can realize savings on both fronts, so much the better.

Perhaps this explains the increased interest in chilled water systems with VPF. VPF designs use fewer pumps and fewer piping connections than primary-secondary systems, which means fewer electrical lines and a smaller footprint for the plant. These factors reduce the initial cost of the chilled-water system, although the savings may be partially offset by additional costs for flow-monitoring and bypass flow (bypass line and control valve). VPF designs may also require more programming for system control than other designs.

As for operating costs, how much a VPF design saves depends on the pressure drops and efficiency of the pumps (see sidebar). A VPF design displaces the small, inefficient, low-head primary pumps used in primary-

Operational savings of VPF designs

Bahnfleth and Peyer¹⁵ discuss the operational savings of VPF designs. For many common systems, however, the primary pump power on which they base their assessment may be too high.

Dispelling a common misconception

True or false: “Chillers operate more efficiently in a system with variable rather than constant primary flow because of the greater log mean temperature difference (LMTD).”

It is true that the return water temperature in a properly operating VPF system remains constant as the amount of flow changes. It is also true that the LMTD can be increased by changing the production (primary) side of the chilled-water loop from constant to variable flow. But there are other facts to consider.

In a system with constant primary flow:

- Entering-evaporator temperature and LMTD fall as the cooling load diminishes.
- The convective heat transfer coefficient, like the primary flow, remains constant despite reductions in load.

In a system with variable primary flow:

- The convective heat transfer coefficient in the chiller evaporator decreases with a reduction in flow.
- Reduced flow decreases the overall heat-transfer effectiveness of the chiller evaporator.

The net effect is that the power consumption for a given chiller is virtually the same whether the chiller’s evaporator flow is variable or constant.

secondary systems. The pressure drops previously satisfied by the distribution pumps are instead satisfied by the now larger primary-only pumps, permitting selection of larger, more efficient pumps (with efficiencies similar to those of the secondary pumps in a primary–secondary system).

VPF systems present building owners with several cost-saving benefits that are directly related to the pumps. The most obvious cost savings result from eliminating the constant flow primary pumps, which, in turn, avoids the material and labor expenses incurred with the associated piping connections, mechanical room space, and electrical service. Although the number of pumps is reduced, the sizes of both the pumps and the variable-frequency drives increase since the pumps must be sized to overcome the entire system’s pressure drop. This offsets some of the installed cost savings of having fewer pumps.

Building owners often cite pump-related energy savings as the reason they installed a VPF system. With the help of a software analysis tool such as System Analyzer™, TRACE™ 700, Chiller Plant Analyzer, or EnergyPlus, you can determine whether the anticipated energy savings justify the use of variable-primary flow in a particular application.

It may be easier to apply a variable-primary-flow system rather than a primary–secondary system to an existing constant-flow chilled-water plant. Unlike the primary–secondary design, the bypass can be positioned almost anywhere in the chilled-water loop and an additional pump is unnecessary.

Chiller selection requirements

Variable-flow systems require chillers that can operate properly when evaporator flow varies. Varying the water-flow rate through the chiller evaporator poses two control challenges for those who design and operate VPF systems:

- 1 Maintaining the chiller flow rate between the minimum and maximum limits of the evaporator
- 2 Managing transient flows without compromising stable operation, especially in multi-chiller plants

Evaporator flow limits

Select for a minimum evaporator-flow limit that is ≤60 percent of the chiller’s design flow rate. One benefit of VPF systems is reduced pumping energy. To realize this benefit, chilled water flow must not remain constant. As the flow decreases, it approaches the minimum flow rate of the chillers—so, how do we select for a minimum chiller flow rate that will result in the pump-energy savings?

The answer depends on the type of chiller, but generally speaking, *lower is better* because it extends the ability of a single chiller to operate at low loads without bypass flow. Most of the potential savings are realized by the time that the system flow rate decreases to 50 percent of design.

Experience with actual VPF plants indicates that a minimum evaporator-flow limit of 60 percent for packaged chillers and 40 percent or less for configured chillers work well.

Chiller manufacturers specify minimum and maximum limits for evaporator water flow. Their objective?

- To promote good heat transfer and stable control (minimum flow limit)
- To deter vibration and tube erosion (maximum flow limit)

In the past, the typical range for water velocity in a chiller was 3 to 11 feet per second. Today, manufacturer-conducted testing shows that specific chillers may accommodate evaporator flow rates as low as 1.5 feet per second, depending on tube type. This is good news for VPF systems because it extends the chiller's ability to operate effectively without the addition of bypass flow.

The minimum flow limit for a chiller can be lowered by selecting an evaporator with more passes (a common option for machines with cooling capacities of 150 tons or more). Granted, more passes may require a higher evaporator pressure drop and more pumping power (Table 13). However, as the system flow rate decreases, the evaporator pressure drop also decreases by approximately the square of the flow rate reduction. Therefore, the pump requires less extra power to work against the pressure drop as the system flow rate drops below the design value.

The other benefit of the added pass is better turndown with a wider evaporator ΔT , which starts at a lower design flow rate for the same cooling capacity. In the case of the two-pass chiller, when using a 15° ΔT , the chiller invoked minimum flow *prior* to reaching the 50 percent system flow rate. This could cause a more complicated transition from one to two chillers, as discussed in the sections on "Managing transient water flows" on page 59 and "Chiller sequencing in VPF systems" on page 63. The other issue is that more pumping energy will be used in the system that requires bypassed flow more of the time.

Table 13. Effect of number of passes on minimum evaporator flow and pressure drop at reduced flow with packaged chillers¹

	Design flow rate gpm [L/s]	Evap. pressure drop at design flow, ft. water [kPa]	Evap. pressure drop at 80% flow rate, ft. water [kPa]	Evaporator pressure drop at 50% flow rate, ft. water [kPa]	Minimum flow rate, gpm [L/s]	Evaporator pressure drop at minimum flow rate, ft. water [kPa]
2 pass	180 [11.4]	13.7 [40.9]	9.0 [26.9]	3.5 [10.5]	77 [4.9]	2.6 [7.8]
3 pass	180 [11.4]	42.6 [127.3]	28.7 [85.8]	11.9 [35.6]	52 [3.3]	4.0 [12.0]
2 pass (15° ΔT)	113 [7.4]	5.6 [16.7]	3.5 [10.5]	flow too low, use min. 2.5 [7.5]	77 [4.9]	2.5 [7.5]
3 pass (15° ΔT)	116 [7.3]	19.6 [58.6]	12.8 [38.3]	5.0 [14.9]	52 [3.3]	4.0 [12.0]

¹ Chillers may have slight differences in capacity, depending on which variable (flow, capacity, or ΔT) is allowed to adjust.

Small packaged chillers typically offer less design flexibility than larger machines. It may not be possible to select a small packaged chiller with a minimum flow rate of less than 60 percent of the design system flow... but don't let this deter you from designing a VPF plant that includes small packaged chillers. Remember, pump power drops with the cube of the reduction in flow, so even a modest 20 percent decrease in flow results in a 50 percent pump energy reduction. A 40 percent flow reduction yields an 80 percent pump energy reduction. The key to making variable flow with limited flow turndown work properly is devising a plant layout and sequencing strategy that accommodates the chiller's minimum evaporator-flow limit.

Managing transient water flows

The second requirement of the selected chillers is proper control during "transient flows." This situation refers to the hydraulic effects caused by an isolation valve when it opens (before the associated chiller starts) or closes (after the chiller stops). To illustrate what happens, let's look at an example.

Assume that the two-chiller VPF system in Figure 37 is designed for a 16°F [8.9°C] ΔT and that it delivers 40°F [4.4°C] chilled water. The temperature of the return water remains relatively constant at 56°F [13.3°C], provided that the coils and two-way valves function properly. Only Chiller 1 operates when the cooling load is low; the isolation valve for Chiller 2 remains closed.

As the cooling load increases, the pump controller increases the rate of chilled water flow through the system. Chiller 2 starts when Chiller 1 can no longer produce 40°F [4.4°C] water. Opening the isolation valve for Chiller 2 almost instantly reduces the flow rate through Chiller 1 by half (Table 14), which effectively doubles the ΔT. Chiller 1's controller will unload the machine as quickly as possible, but in the interim, it will attempt to produce a 32°F ΔT [0°C] and cool the water to 24°F [-4.4°C]. If the chiller cannot unload quickly enough, built-in fail-safes should stop and lock out the chiller before damage occurs... but at the expense of satisfying the cooling load. The system can be designed and operated to keep this scenario from occurring. This information is provided in the following sections.

Table 14. Flow-rate changes that result from isolation-valve operation

	Number of operating chillers				
	1	2	3	4	5
Flow-rate reduction when an isolation valve opens*	50%	33%	25%	20%	17%

*Flow-rate reduction is expressed as a percentage of the actual chilled water flow rate prior to transition:

$$\% \text{ flow-rate reduction} = 1 - \frac{\text{number of chillers operating}}{\text{number of chillers operating} + 1}$$

Select for the greatest tolerance to large changes in flow rate. The objective is to simplify system control by minimizing the need for "supplemental" demand limiting or valve control as chillers come online. Chillers that are well-suited for variable primary flow can tolerate and respond to rapid flow-

rate changes (Table 14). Selecting chillers with these characteristics improves the likelihood of stable, uninterrupted operation.

Estimate the expected flow-rate changes and *make sure that the chillers you select can adapt to them*. For example, one of the newest unit controllers on the market can reliably maintain the desired chilled water temperature with a flow-rate reduction of 50 percent per minute. Figure 38 shows the response of a chiller equipped with this controller in a more extreme situation. The flow dropped 67 percent in 30 seconds, with limited effect on the leaving chilled water temperature. Another, less robust chiller controller permits flow-rate changes of less than 2 percent per minute and would need 25 minutes to adapt to a flow-rate reduction of 50 percent. Fluctuations of 2 percent or more are typical, even during normal system operation. Attempting to limit flow-rate changes to this extent while starting or stopping a chiller is impractical, if not impossible.

When comparing prospective chillers, consider the transient-flow tolerance of the unit controllers. Then *work closely with the chiller manufacturer* to devise a flow-transition sequence that accounts for the unique operating characteristics of both the chiller and the application. Transient flow rate control is discussed in more detail on page 65.

Figure 38. Example of chiller control responsiveness to flow-rate reduction*

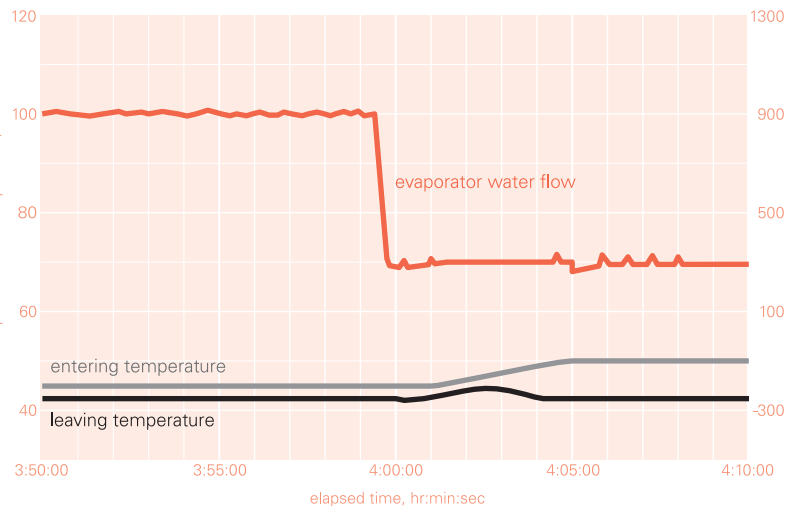

*Data represents a Trane AdaptiView™ and CH530 chiller controller with flow compensation.

Select for nearly equal pressure drops across all chiller evaporators. A VPF design loads and unloads the chiller(s) based primarily on the rate of water flow through the evaporator. If a difference in size or type of evaporator gives one chiller a lower pressure drop than the others in the plant, that chiller will receive a higher rate of water flow and a correspondingly greater load.

Dissimilar pressure drops can make it difficult to provide stable plant operation. Table 15 demonstrates this effect in a two-chiller system (similar to the one shown in Figure 37). In this case, more water flows through Chiller 1's

evaporator because its selection pressure drop is lower than that of Chiller 2. Load is proportional to flow rate and temperature difference, $\text{tons} = (\text{gpm} \times \Delta T) / 24$. Because Chiller 1 is asked to satisfy a load that exceeds its capacity, it cannot satisfy the chilled water setpoint when the return water temperature equals the design condition. Meanwhile, Chiller 2 is less than fully loaded.

Balancing the system at the design condition, for example, by installing a balancing valve in series with Chiller 1, reduces this problem and works well at design and part load conditions. Alternatively, you could increase the load on Chiller 2 by lowering its chilled water setpoint; however, this complicates system control. The simplest solution is to select chillers that have (nearly) equal pressure drops at their design flow rates, whether the capacities are the same or not.

Table 15. Effect of dissimilar evaporator pressure drops

	Capacity, tons	Flow rate, gal/min		Pressure drop, ft H ₂ O*		
		Selection	Actual	Selection	Actual	Change, %
Chiller 1	500	750	819	12	14.3	+9.2
Chiller 2	300	450	381	20	14.3	-15.3

*Values shown here are based on the assumption that pressure drop changes with the square of the flow rate.

System design and control requirements

If experience has taught us anything about implementing variable primary flow, it's this: The single, most important contribution of the engineer is to **provide written, detailed descriptions of the plant's sequence of operation.**

These descriptions should include control sequences for:

- Full- and part-load operation
- Minimum and maximum flow-rate management
- Transient flow-rate changes
- Starting and stopping chillers

Furthermore, this information must be shared *early in the design process*. Without specific, documented sequences of operation, it is unlikely that the controls provider will devise programs that operate the plant as intended. Bottom line: VPF plants *that work* result from close, early-on collaboration between the engineer, the chiller manufacturer, and the controls provider. Variable primary flow is a value-added option that can help your clients curb operating costs at a lower initial cost than traditional primary–secondary designs ... but only if you select the right components, install them properly, and operate them in accordance with a well-thought-out control scheme.

Accurate flow measurement

The success of a variable-primary-flow installation depends on the quality of the flow-measuring device that controls the system bypass valve (and perhaps also indicates the plant load). Some practitioners use a flow meter¹⁶ to directly detect the flow rate (**C** in Figure 37); others use a differential pressure sensor (**D**) that monitors the change in water pressure across the chiller evaporator and then correlates the pressure differential to a water flow rate.

Select a flow measurement device with accurate and repeatable measurements. Regardless of which type of device you use, the flow meter or differential pressure sensor must be of high quality; that is, the device must provide *accurate and repeatable* measurements. For the plant to operate well, the device also must remain calibrated and perform reliably over time. Purchase prices vary widely, but the adage “you get what you pay for” typically holds true. In our experience, the cost of a suitable flow-measuring device is closer to \$1,000 USD than to \$100 USD. Put simply, don’t compromise on accurate sensing devices when negotiating potential cost reductions during the “value engineering” phase of a project.

One further caveat about measurement accuracy: Proper installation is critical to ensure accurate readings. If the manufacturer states that at least 10 pipe diameters of uninterrupted flow are required both upstream and downstream of the sensing device, then make sure that the piping layout complies.

Select an accurate proof-of-flow device for each chiller. Flow reductions through chillers in VPF systems often cause paddle-type flow switches to flutter or open altogether, which shuts down the chiller. To provide accurate, reliable confirmation of flow, select a sensitive pressure-differential switch (or other high-quality device) and install it properly, piping it across the evaporator.

Bypass locations

A bypass is required whether the primary flow is constant or variable. In a primary–secondary system, the decoupler allows excess primary water to be bypassed. In the VPF system, the bypass allows excess flow only when needed to maintain the chillers' minimum flow requirements.

There are three common locations for the VPF bypass line:

- Place the smaller bypass required for a VPF system in the same position as the bypass in a “decoupled” system. A variable-speed drive on the pump located near the chillers reduces flow and allows substantial energy and operating cost savings. One drawback is that the valve must work against higher pressures—possibly causing wear and lack of controllability.
- Use three-way valves at some of the system coils. While this approach ensures minimum chiller flow, it reduces the pump operating cost-savings, due to the increased system flow and decreased return-water temperature.

- Locate a bypass line and valve near the end of the piping run. The bypass control valve sees a lower operating pressure and may provide more stable control. Some operating cost savings may be sacrificed to maintain the pump-operating pressure at a higher level with the bypass located away from the chillers. The line sizes must be large enough to allow the minimum flow rate.

One final method to ensure minimum evaporator flow is to have a constant load and flow somewhere in the system. However, if in the future the system changes and this constant flow no longer occurs, the system is likely to have operating issues when its flow approaches the chiller's minimum.

Delivering the appropriate bypass flow requires attention to line sizing, control-valve selection, and the response time of the system.

Bypass flow control

In a VPF system, the sole purpose of the bypass line with modulating control valve is to assure that the rate of chilled water flow through each operating chiller never falls below the minimum limit required by the manufacturer.

Select a suitable control valve of high quality. When the bypass line is positioned near the chiller plant (**A** in Figure 37), as it is in many VPF installations, the control valve is exposed to comparatively high operating pressures. Selecting an appropriate valve actuator is critical because the valve must close against this pressure. As for the valve itself, choose one that maintains a linear relationship between valve position and flow rate; otherwise, the valve may permit too much water flow when it begins to open.

Note: A common butterfly valve won't provide the necessary flow characteristics. Some have found that pressure-independent valves work well as a bypass valve. Verify the suitability of a particular valve by requesting flow-versus-position data from the supplier.

Locating the bypass line far from the chiller plant (**B** in Figure 37) lowers the operating pressure for the control valve.

Minimize control lag. Regardless of where the bypass line is situated (at **A** or **B** in Figure 37), the control valve must react quickly to changes in system flow. You can improve control response either by hard-wiring the flow-sensing device, valve controller, and valve actuator; or by selecting devices that communicate directly with each other. Avoid relaying input/output signals through multiple system controllers.

Chiller sequencing in VPF systems

The success of a VPF application depends on more than the chilled-water system. It requires careful orchestration of the *entire* HVAC system, which means air handlers and coil-control valves as well as chillers and pumps.

Proper sequencing helps to maintain the flow rate through each evaporator within the range recommended by the chiller manufacturer. As the system

flow nears the maximum limit for the operating chiller(s), another machine must be brought online. Similarly, as the system load and flow decrease, chillers must be shut down to reduce the need for bypass water flow.

Adding a chiller in a VPF system

The simplest way to control a VPF system is to monitor the leaving-evaporator water temperature and allow the operating chiller(s) to load *almost* fully before bringing the next chiller online. As long as the system can maintain the target temperature, there is no need to activate another chiller.

When the operating chiller(s) no longer provide enough cooling, the plant controller should start the next chiller. For example, when the temperature exceeds the design setpoint by a certain amount (for example, 1.5°F [0.8°C]) for a set time (for example, 15 minutes) an additional chiller starts.

One caveat: The next chiller should start *before* the chilled water flow reaches the maximum limit of the operating chiller(s), even if the operating chillers are not yet fully loaded. (This would rarely happen; most pipe velocity limits are below that of the chillers.)

As chillers are brought online, flow rates may fluctuate substantially, and this occurs quite often in a system with two chillers. All systems, with any number of chillers, will find the most difficult transition when adding or subtracting the second chiller. An example will help explain the challenges.

Table 16. Flow-rate-fluctuation examples

	Design flow rate gpm [L/s]	Minimum flow rate gpm [L/s]	Maximum flow rate gpm [L/s]
Chiller 1	960 [60.6]	576 [36.3]	2,110 [133.1]
Chiller 2	1,440 [90.8]	675 [42.6]	2,474 [156.1]

At a point in time, Chiller 1 is active and has 1,100 gpm [69.4 L/s] flowing through its evaporator. It can no longer satisfy the required system supply temperature. What happens if Chiller 2's valve is opened with no other action taken? If we assume that pressure drops are equal, 550 gpm [34.7 L/s] will flow through each chiller. This means Chiller 1's flow rate drops by 50 percent as fast as Chiller 2's isolation valve opens (probably beyond what its controls can respond to) and we are below each chiller's minimum flow rate. Be aware that this could become an issue since chiller controls may protect the chiller by shutting it off. The result is that some combination of pump speed, bypass valve control, and slow-acting valves at the chillers must do two things:

- Keep change in flow rate within the equipment limitations
- Keep each chiller's flow rate above its minimum

Controlling transient flows is mandatory, regardless of plant size. The number of chillers in the plant will not alter the degree of care needed to properly manage transient flow-rate changes because the transition from one operating chiller to two is inevitable in almost all plants.

Temporarily unload the operating chillers before starting the next one. Reduce shock resulting from transient flows by unloading the operating chillers *before* opening an isolation valve to bring another chiller online.

You can accomplish this by imposing a demand limit of 50 to 60 percent on the operating chillers, or by raising the chilled water setpoint one to three minutes before the isolation valve actuates. (See sidebar.)

Open the chiller isolation valves slowly to encourage stable operation. How slowly? That depends. If the chiller controller can only handle a flow-rate change of 2 percent per minute, then the isolation valve must take 25 minutes to open... far too long for most applications. Besides helping with chiller stability, slow valve operation reduces the likelihood of valve-induced water hammer in the piping system.

With sophisticated chiller controls, a 30-percent-per-minute change in the rate of flow should work well in most applications. At this rate, the isolation valve will transition from fully closed to fully open in about two minutes.¹⁸

Like the bypass valve, be sure to select isolation valves that maintain a linear relationship between valve position and flow rate.

The bottom line is that control of VPF systems *must* be considered during system design.

Subtracting a chiller in a VPF system

Subtracting a chiller in a VPF system is not simple, either. It is important to devise a “stop” strategy that protects the chillers from short-cycling. Knowing when to stop a chiller (to provide sufficient downtime between chiller starts) often is more challenging than knowing when to start it. The most reliable way to do so—assuming that the VPF system is properly installed, calibrated, and maintained—is to *monitor the power draw of the operating chillers*. (See sidebar.) Most unit controllers measure running load amps (RLA) at regular intervals. The %RLA (actual RLA divided by design RLA) provides a good indication of the present chiller load.

Base the “stop” strategy for a multi-chiller plant with *equally sized machines* on the sum of the present %RLA for all chillers divided by the number of operating chillers *minus one*. If the result is less than the desired capacity for the operating chiller(s), then stop one of the machines.

For example, suppose that a plant consists of three equally sized chillers, each of which is presently running at 60 percent of full-load capacity. If one chiller is shut off, the two chillers still online would operate at approximately 90 percent of full-load capacity; $(60\% + 60\% + 60\%) / (3-1) = 90\%$. Having the remaining two chillers operating almost fully loaded risks the need to restart a chiller if the load increases.

In his article, “Primary-Only vs. Primary-Secondary Variable Flow Systems,” Steven T. Taylor, principal of Taylor Engineering LLC, notes that unloading the active chillers before starting another produces warmer chilled water. Although the temperature increase seldom causes problems for comfort cooling, it may be unacceptable in industrial/process applications.¹⁷

Sequencing based on load

Some plant operators prefer to sequence chillers by comparing the actual system load with the total plant capacity that would result if a chiller is turned off. However, this method can be less reliable than one based on power draw because flow- and temperature-sensing devices require periodic recalibration to correct for drift.

A more conservative approach might be to wait to turn off the chiller until it would result in no higher than 80 percent capacity for the remaining operating chillers. Going back to the example, if the desired (n-1) chiller capacity were 80 percent, it would *not* be appropriate to shut down a chiller. In this case, the plant controller should not turn off any of the chillers until each of them unloaded to 53 percent; $(53\% + 53\% + 53\%) / (3-1) = 80\%$.

Note: For plants with unequally sized chillers, weight the %RLA value of each chiller by its design capacity and compare the weighted value with that of the chiller to be sequenced off.

The other thing that must be checked before subtracting a chiller is how the system flow can be handled by one less chiller. As an example, suppose that two chillers are running near their minimum flow. Chiller 1 is at 650 gpm [41.0 L/s] and Chiller 2 is at 760 gpm [47.9 L/s], so the system total is 1,410 gpm [88.9 L/s].

Choice 1: Turn off Chiller 1. It is obvious that we should be able to turn Chiller 1 off and satisfy system load as long as the flow rate doesn't increase too rapidly. However, the current system flow rate is close to Chiller 2's design flow rate of 1440 gpm [90.8 L/s], and if the system flow increases, we may need to restart Chiller 1.

Choice 2: Turn off Chiller 2. If Chiller 1 has a condenser water temperature lower than design, its capacity has increased. Could we turn off Chiller 2? Chiller 1's flow is certainly within the allowable limits, but it may or may not be able to supply the required capacity. In this case, the dilemma is to ensure that there is enough chilled water capacity after a chiller is turned off.

Obviously, control is an extremely important aspect of a VPF system.

Other VPF control considerations

Select slow-acting valves to control the airside coils.

Valves that open and close slowly moderate the normal fluctuations of chilled water flow through the loop.

Use multiple air handlers, and stagger their start/stop times.

Unless it is programmed to do otherwise, the building automation system will simultaneously shut down all of the air handlers when the occupied period ends. If two chillers are operating when this happens—and if all of the coil-control valves close at the same time—then chilled water flow through the evaporators will drop to zero almost instantaneously. Such a dramatic change not only causes problems for the chillers, but also may deadhead the pumps.

To help ensure that flow-rate changes remain within acceptable limits, "divide" the air handlers into several groups. Then implement control schedules that shut down each group individually at 10-minute intervals.

Plant configuration

Consider a series arrangement for small VPF applications.

For more information, refer to the Trane *Engineers Newsletter*, "Don't Overlook Optimization Opportunities in 'Small' Chilled Water Systems" (ADM-APN009-EN).

When the plant consists of only two chillers *and expansion is unlikely*, you can simplify control by piping the evaporators in series. Doing so avoids flow transitions because the water always flows through *both* chillers. The series arrangement requires careful selection because the pump must be sized for the pressure drop through *both* chillers. However, the extra pressure quickly decreases (by roughly the square of the flow rate) as the flow rate slows. For example, at 80 percent of design flow, the evaporator pressure drop is only 64 percent of design. Given this operating characteristic, a VPF design may permit a slightly higher system pressure drop than a comparable primary-secondary system without a noticeable penalty in operating cost. "Series Chillers" on page 44 discussed these arrangements in greater detail.¹⁹

Note: To further reduce the system ΔP , lower the required rate of chilled-water flow through the system by increasing the temperature difference between the supply and return. Plants that supply 40°F [4.4°C] chilled water based on a ΔT of 16°F [8.9°C] or more are increasingly common.

Assess the economic feasibility of VPF for single-chiller plants.

Although most VPF applications consist of two or more chillers, variable primary flow also offers potential operating-cost savings in a new or existing single-chiller plant. Instead of a bypass line and flow-sensing devices, minimum flow through the chiller can be maintained by three-way valves. (Use enough three-way valves to assure that the minimum evaporator-flow rate of the chiller is always satisfied.) This simple approach will reduce pumping costs while providing the chiller with enough chilled water.

To quantify the savings potential of variable versus constant primary flow in a single-chiller plant, we examined a two-story office building in St. Louis, Missouri. The HVAC system includes a 50-ton scroll chiller and a 5-hp chilled water pump. Figure 39 illustrates the results of our analysis. Although the absolute savings are not large, variable primary flow *did* reduce the cost of operating the chilled water system by more than 6 percent ... enough to warrant further investigation. The difference in installed costs is a variable-speed drive, a differential pressure sensor, and a pump controller.

Figure 39. Example of operating-cost savings for a VPF, single-chiller plant

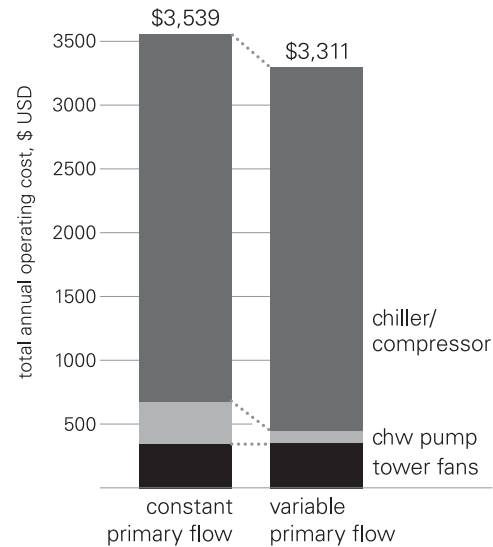

Analysis results are based on a 50-ton scroll chiller and a 5-hp chilled water pump for two-story office building in St. Louis, Missouri.

Moderate “low ΔT syndrome” by manifolding the chilled water pumps

Manifolding two or more chilled water pumps (or slightly oversizing a single pump) can provide an individual chiller with more than its design chilled water flow... which means that you can fully load the chiller even if the return water temperature is colder than design.

Sometimes described as “overpumping,” this strategy does not cure “low ΔT syndrome”; it merely reduces the adverse effect of low ΔT on system operation.²⁹ (Refer to “Low ΔT syndrome” on page 79). An example of low ΔT syndrome is receiving a depressed (for example, 49°F [9.4°C]) return-water temperature rather than the design (for example, 56°F [13.3°C]) return-water temperature.

Again, the only methods to load the chiller are to decrease the chilled-water leaving temperature or to increase the flow. If the pumping power and speed allows, the operator may be able to increase the chiller’s flow rate and capacity. Do not exceed the pump’s operating envelope.

Guidelines for a successful VPF system

Chiller selection

- Select for the lowest possible minimum evaporator-flow limit (no more than 40–60 percent of system flow)
- Select for the greatest tolerance to large flow-rate changes, while maintaining required temperature setpoint
- Select chillers with approximately equal pressure drops across the evaporator at the design flow rate

- Understand the specific loading/unloading characteristics of the chiller controller

Bypass flow

- Select a high-quality control valve with linear-flow characteristics
- Select flow-sensing devices that deliver precise, repeatable measurements
- Minimize control lag by hard-wiring the controls or by selecting devices that communicate directly

Chiller sequencing

- Temporarily unload the operating chillers before starting the next
- Open chiller isolation valves *slowly* to encourage stable operation
- Let the operating chiller(s) load *almost* fully before starting another
- Prevent short-cycling by devising a “stop” strategy based on the power draw of the operating chillers

Plant configuration

- Consider a series arrangement for small VPF applications to avoid transient flows
- Assess the economic feasibility of variable primary flow for single-chiller plants
- Moderate “low ΔT syndrome” by manifolding multiple chilled-water pumps or slightly oversizing a single chilled-water pump
- Take care to properly manage transient flows regardless of the number of chillers in the plant

Airside control

- Select slow-acting valves to control the chilled-water coils
- Use more than one air handler and stagger their start/stop times

Chilled-Water System Variations

A number of chilled-water system variations can and should be used when appropriate. Each configuration offers specific advantages to solve problems and add value to the system.

Heat Recovery

ASHRAE/IESNA Standard 90.1–2007²⁰ requires heat recovery in specific applications. Indoor air quality concerns have spurred the use of systems that subcool supply air to dehumidify, then temper, the air to satisfy space conditions. ASHRAE/IESNA Standard 90.1–2007 limits the amount of new reheat energy used in these applications. With these drivers, and energy costs, there has been a resurgence of heat recovery chillers. The example on page 75 describes a cost-effective recovered-heat strategy. This scheme is commonly used for service-water heating in resort hotels and for certain process loads.

A separate application manual²¹ discusses heat recovery, as does an *Engineers Newsletter*²², so it is not discussed in depth in this manual. However, considerations for heat recovery on chilled-water system design are discussed.

Figure 40. Sidestream plate-and-frame heat exchanger

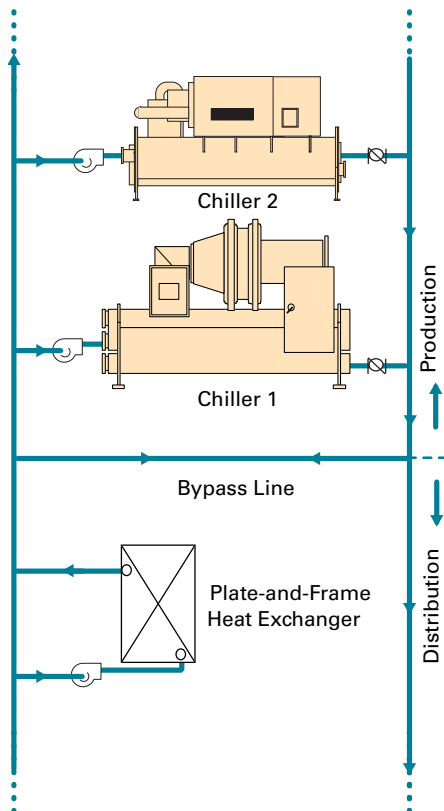

Condenser “Free Cooling” or Water Economizer

There are several ways to accomplish free cooling through the use of a water economizer circuit. Three common techniques for chilled water systems are using a plate-and-frame heat exchanger, refrigerant migration, or well, river, or lake water. Each technique is discussed in more detail below and in an *Engineers Newsletter*²³.

Plate-and-frame heat exchanger

A plate-and-frame heat exchanger may be used in conjunction with a cooling tower to provide cooling during very low wet-bulb temperature conditions. When it is to be used for these purposes, designers often specify a cooling tower larger than necessary for design conditions so that it can be used for many hours with the plate-and-frame heat exchanger.

In this type of water economizer, the water from the cooling tower is kept separate from the chilled-water loop by a plate-and-frame heat exchanger. This is a popular configuration because it can achieve high heat-transfer efficiency without cross-contamination. With the addition of a second condenser-water pump and proper piping modifications, this heat exchanger can operate simultaneously with the chiller, provided the chiller is placed downstream of the heat exchanger (as shown in Figure 40). As much heat as possible is rejected through the heat exchanger while the chiller handles the rest of the cooling

load. The details of operation are discussed in “Sidestream plate-and-frame heat exchanger” on page 74.

Plate-and-frame heat exchangers isolate the building loop from the water in the open cooling tower loop, but they must be cleaned, typically annually. The labor and parts for cleaning and reassembly (e.g., gasketing) is an expense that should be factored into the life-cycle cost of this option.

Refrigerant migration

Another method of “free” cooling is to transfer heat between the cooling tower water and the chilled water inside a centrifugal chiller through the use of refrigerant migration, also known as a thermosiphon. Figure 41 shows a centrifugal chiller equipped for refrigerant migration free cooling. When the temperature of the water from the cooling tower is colder than the desired chilled-water temperature, the compressor is turned off and automatic shut-off valves inside the chiller refrigerant circuit are opened, as shown in Figure 42. Because refrigerant vapor migrates to the area with the lowest temperature (and pressure), refrigerant boils in the evaporator and the vapor migrates to the cooler condenser. After the refrigerant condenses, it flows by gravity back through a shutoff valve to the evaporator. This allows refrigerant to circulate between the evaporator and condenser without the need to operate the compressor.

Depending on the application, it is possible for refrigerant migration in a centrifugal chiller to satisfy many hours of cooling load without operating the compressor. Free cooling chillers serving systems that can tolerate warmer chilled-water temperatures at part-load conditions can produce more than 60 percent of the rated capacity without compressor operation. There are no cooling coil fouling concerns because the cooling-tower water flows through the chiller condenser and is separate from the chilled-water loop. There is no additional expense for cleaning, as the condenser tubes are the same as those used for normal cooling mode and should already be on a maintenance schedule. In addition, fewer pipes, pumps, and fittings are required, and no additional heat exchanger is required.

Figure 41. Refrigerant migration chiller in compression cooling mode

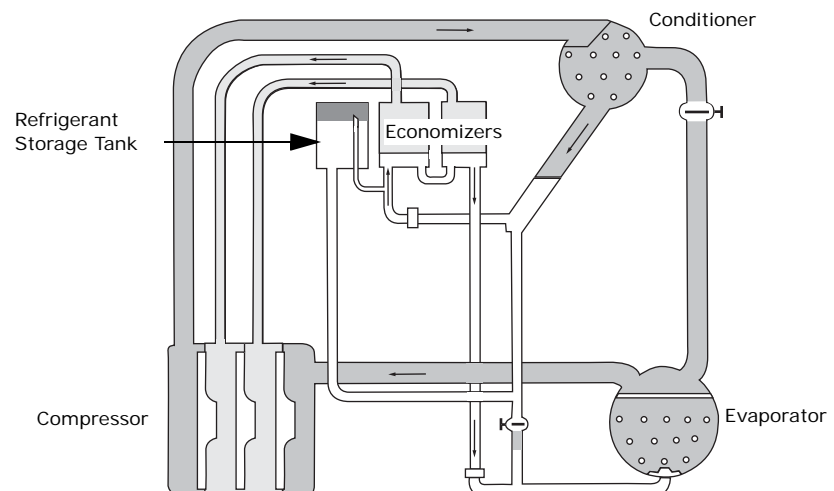
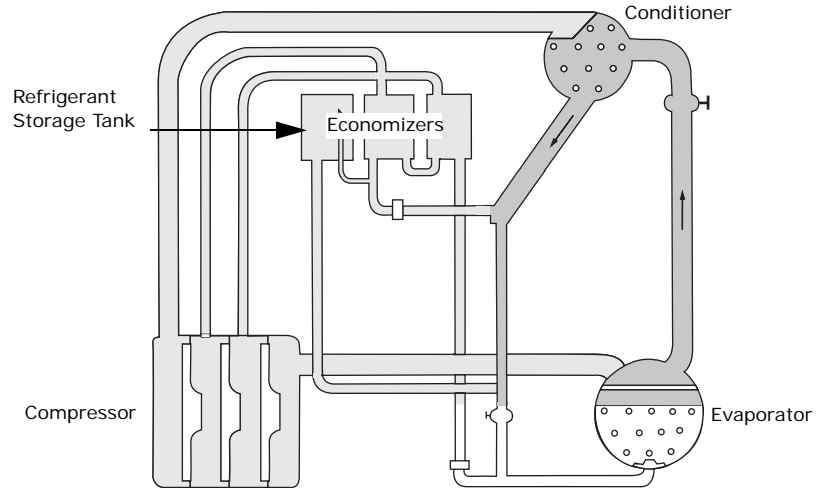
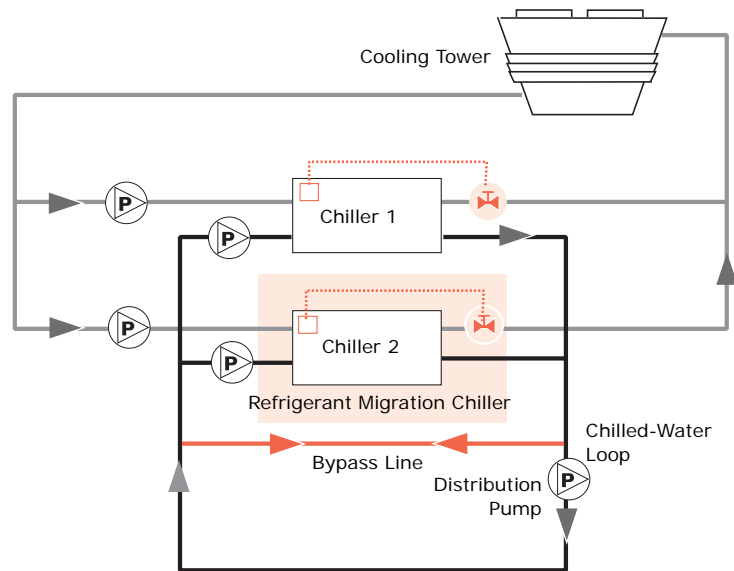

Figure 42. Refrigerant migration chiller in free-cooling mode



One option is to equip one or more parallel chillers with the refrigerant migration cycle (Figure 43). This essentially turns the chiller into a shell-and-tube heat exchanger run-around loop.

Figure 43. Water economizer piped in parallel with chillers



Well, river, or lake water

There are times when well, river, or lake water will be pumped through the condenser. In these cases, examine the cost of pumping the water versus the benefit of more water passing through the condenser. The environmental limitations imposed by local codes are another consideration. Some locales will not allow well water to be dumped after being used. Other local authorities limit the maximum water temperature that may be returned to a

body of water. Flow rates need to be carefully selected to balance the economic and environmental requirements.

Preferential Loading

Preferential loading is desirable for systems that use heat recovery or free cooling to allow the equipment used in these schemes to remain more fully loaded. In a heat recovery system, a more heavily loaded heat recovery chiller produces more heat that can be recovered for the desired process. Similarly, if the condenser free cooling method is preferentially loaded in the sidestream arrangement discussed below, it receives the warmest return water temperature and thus continues to operate as load and/or condenser water temperature increases.

Preferential loading may also be beneficial for use with either a high-efficiency chiller that should be fully loaded whenever possible, or a chiller using a fuel other than electricity, such as an absorption chiller using waste steam from a cogeneration plant, or a chiller coupled with an engine that generates electricity. When used with the latter, the system is able to preferentially load the alternate fuel chiller when the cost of electricity is high.

Preferential loading - parallel arrangement

If a chiller in a decoupled system is moved to the distribution side of the bypass line in a primary-secondary system, due to system hydraulics and temperatures, the chiller is preferentially loaded when it is turned on. As shown in Figure 44, Chiller 1 always receives the warmest system water and is preferentially loaded. As previously discussed, chillers on the production side of the bypass line (Chillers 2 and 3) are loaded to equal percentages. The parallel preferential arrangement works best if Chiller 1 is capable of creating the desired system supply water temperature, as it will be sending chilled water directly to the distribution system.

Figure 44. Parallel preferential loading arrangement

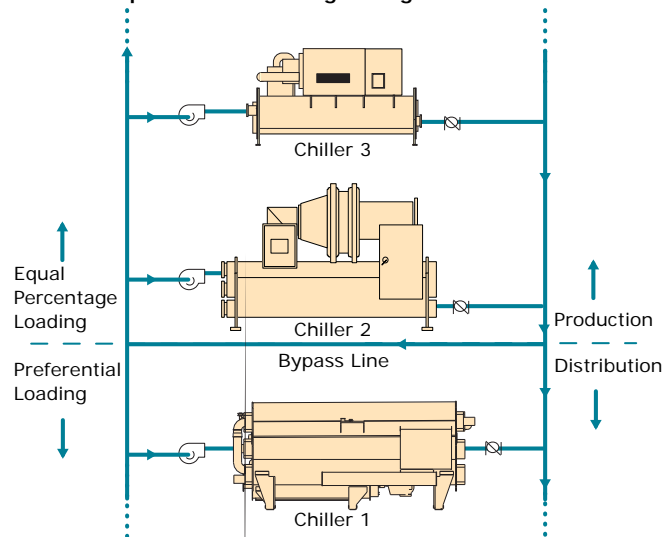

One caveat when applying this arrangement is that chillers on the production side of the bypass line will run more often at low part-load conditions. Older chillers or newer chillers with a high cycle point may not have this capability.

Preferential loading - sidestream arrangement

Figure 45. Sidestream preferential loading arrangement

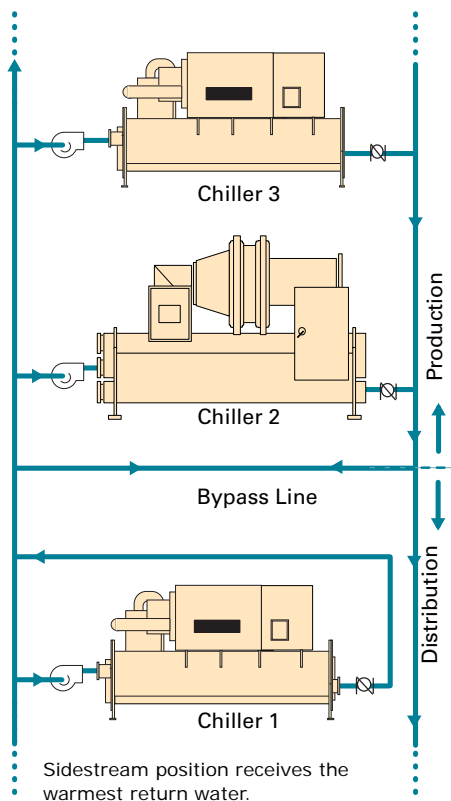

Figure 45 shows a simple modification to the traditional decoupled arrangement. The sidestream arrangement ensures that the chiller piped in the sidestream position still receives the warmest entering-water temperature and can fully load it whenever the chiller plant operates.

This arrangement is unique because it not only allows preferential loading, but it also permits the cooling device (chiller, heat exchanger, etc.) in the sidestream position to operate at any leaving-water temperature. This configuration precools the system-return water for the chillers downstream, reduces their loads and energy consumption, and decreases the overall operating cost of the chilled-water system.

When cooling devices are located in the return piping of the distribution loop, they do not contribute to system demands for flow. They simply reduce the temperature of return water to the production loop. While this is counterproductive to the principle of striving for the highest possible return water temperature, it is often the best way to obtain free cooling, specialized heat recovery, or reduce the capital cost of ice storage equipment.

Sidestream, decoupled applications are usually most economical when the sidestream chiller is smaller than those on the production side of the bypass line. Since pumping requirements and energy consumption change with modifications to the system arrangement, it is best to use a computerized analysis tool to model the economic effects.

The following are different system configurations that can benefit from the sidestream application.

Sidestream plate-and-frame heat exchanger

A free-cooling heat exchanger may be capable of chilling water to only 48°F [8.9°C] during some periods. Rather than overlook this portion of cooling capacity assistance, the heat exchanger does whatever it can to its portion of the total return stream. Figure 40 on page 70 shows a possible chilled- and condenser-water piping arrangement that allows for simultaneous waterside economizer and chiller operation. Chillers operating downstream can reduce chilled-water temperature further, allowing simultaneous free cooling and mechanical cooling. This configuration increases the hours that the heat exchanger may be used. Since this capacity is brought to bear on the warmest water in the system, it allows the highest heat exchanger effectiveness and has the greatest impact.

Sidestream heat recovery

Referred to as “distribution sidestream,” an alternative location is to apply the chiller at the air handler that requires reheat. The heat recovery chiller can cool either the supply or return chilled water. If only a small amount of heating is needed, this may be accomplished with a water-to-water heat pump.

A similar situation occurs if a heat-recovery chiller is placed in this sidestream position²⁴ (see Figure 46). This chiller may be equipped with a heat recovery condenser or it could be a standard, single-condenser chiller operating as a heat pump in a heating control mode. The chiller may not be capable of cooling water to the system supply temperature. That is unimportant with this configuration. Think of the machine as a heater instead of a chiller. Its primary function is heating, and cooling is a beneficial by-product. The passing return-chilled-water stream appears as an infinite heat source to the heat recovery chiller. The chiller only cools its evaporator water enough to satisfy the heating demand. This avoids the control predicament of deciding how to reject surplus condenser heat when the cooling and heating loads of a chiller do not strike a perfect heat balance.

Figure 46. Heat recovery chiller in sidestream position

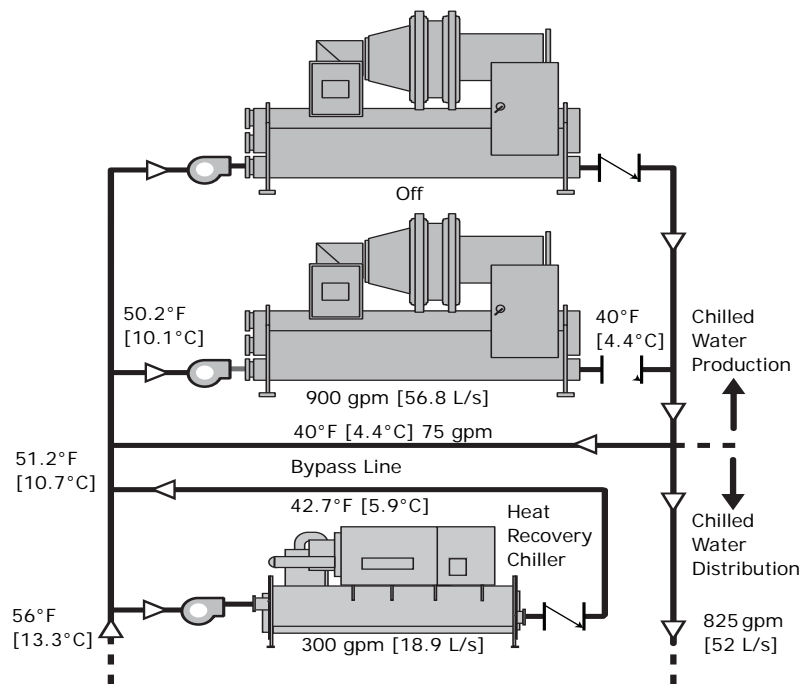

Sidestream with alternative fuels or absorption

An absorption chiller may be applied in a sidestream location. This allows the chiller to be loaded whenever utility rates make it beneficial. It also ensures that the absorption water chiller receives the warmest entering-water temperature, allowing it to operate more efficiently and produce more cooling.

Sidestream system control

The flexibility of sidestream applications is increased by the fact that the devices are used to pre-cool return water, not to produce the system chilled-water temperature. This means that they may be loaded by a different signal. In the case of a plate-and-frame heat exchanger, as long as return water is being cooled, there is an advantage to using it. A heat-recovery chiller can be loaded to produce just the amount of hot water necessary using the condenser-water leaving temperature as a signal. If preferential loading is used with an absorption chiller, it may be loaded simply by decreasing its leaving-water temperature.

Sidestream configurations may also be used to preferentially load chillers or a heat exchanger used in a variable-primary-flow system, or to isolate chillers that are incapable of the same flow variations as the rest of the system.

Preferential loading – series arrangement

As previously discussed in “Series Chillers” on page 44, preferential loading is very simple when chillers are placed in series. If both the upstream and downstream chillers are given the system leaving water temperature setpoint, the upstream chiller is preferentially loaded and the downstream chiller operates whenever the upstream chiller can no longer achieve setpoint. If the downstream chiller is given the system setpoint, and the upstream chiller is given a warmer setpoint, then the downstream chiller loads first. Another method for preferential loading uses compressor RLA to determine when to bring on the next chiller.

Figure 47. Preferential loading - series arrangement

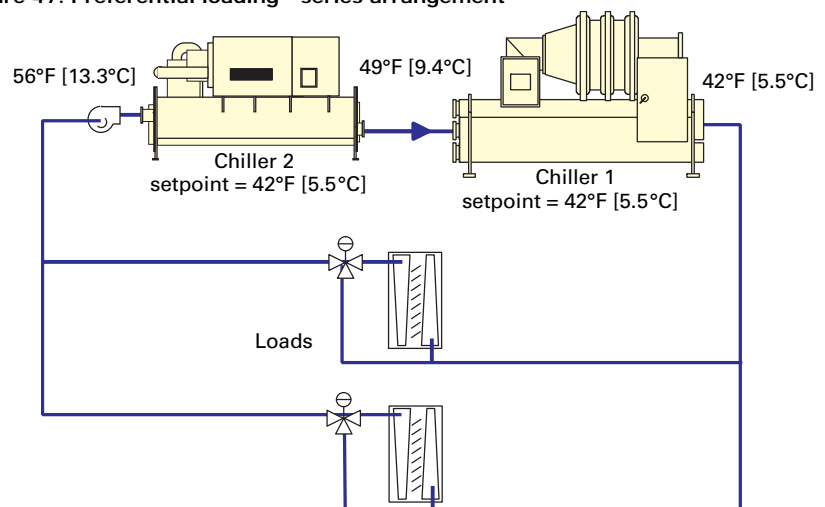

Series-Counterflow Application

The series-counterflow configuration can work with all types of chillers. Duplex™ chillers are shown in Figure 48. A single large chiller may be built as a Duplex machine, and would itself constitute a series-counterflow arrangement. The evaporator and condenser water circuits are common to both halves of the Duplex. Increased efficiency comes from the separation of the compressors and refrigerant circuits.

Another system configuration that can be very energy efficient incorporates the previously described series application, but does so for both the chilled water *and* condenser water. Figure 48 shows such a configuration. The chilled- and condenser-water flow directions are opposite, or counter, to one another (thus the name, series-counterflow).

Note that the downstream machine, in this case, produces 40°F [4.4°C] chilled water, while the upstream machine produces 50°F [10°C] chilled water. The downstream machine receives 85°F [29.4°C] condenser water, while the upstream machine receives 95°F [35°C] condenser water. Therefore, the pumping requirements are only 1.2 gpm/ton on the chilled water side and 1.5 gpm/ton on the condenser water side—greatly reducing pumping, piping, and cooling tower costs. The configuration has the effect of equalizing each chiller's required lift, as shown in Figure 49.

Figure 48. Series-counterflow arrangement

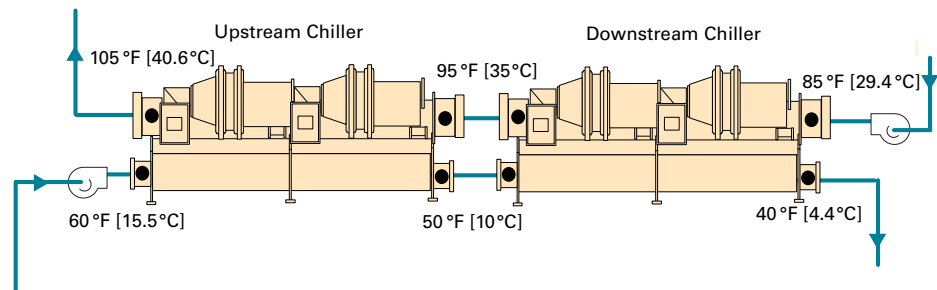
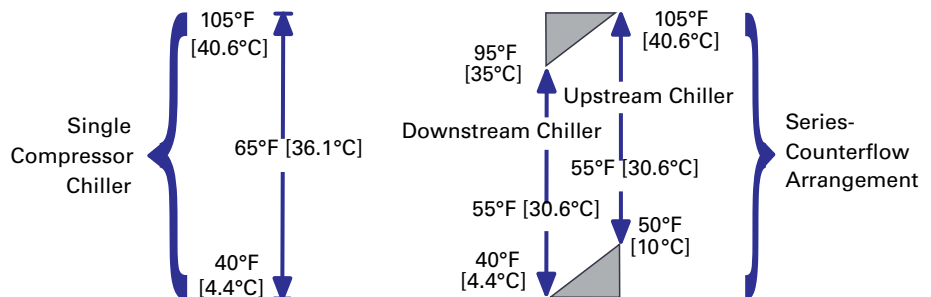

Figure 49. Equal lift concept



Series-series counterflow

For more information, refer to the *ASHRAE Journal* article, "Series-Series Counterflow for Central Chilled Water Plants." **19**

Figure 48 shows two Duplex™ chillers in series. Chiller module (combination of two Duplex chillers) power savings can be as high as 19% compared with a single chiller operating at the same conditions. Because the Duplex chiller is actually two refrigerant circuits in series on a common water circuit, Figure 48 operates with the efficiency of four chiller circuits in a series-counterflow arrangement. But system control is simply for two chillers in

series. The left half of Figure 50 shows a modularized configuration where series chiller modules are placed in parallel with each other, so that any upstream chiller's valves could be "paired" with virtually any downstream chiller by opening the appropriate valves. The condenser side in a counterflow arrangement is shown in the right half of Figure 50. The advantages of this system for large chilled water systems include highest efficiency, scalability as the project grows, and high redundancy without a significant investment in extra equipment.

Figure 50. Series arrangement of evaporators and condensers

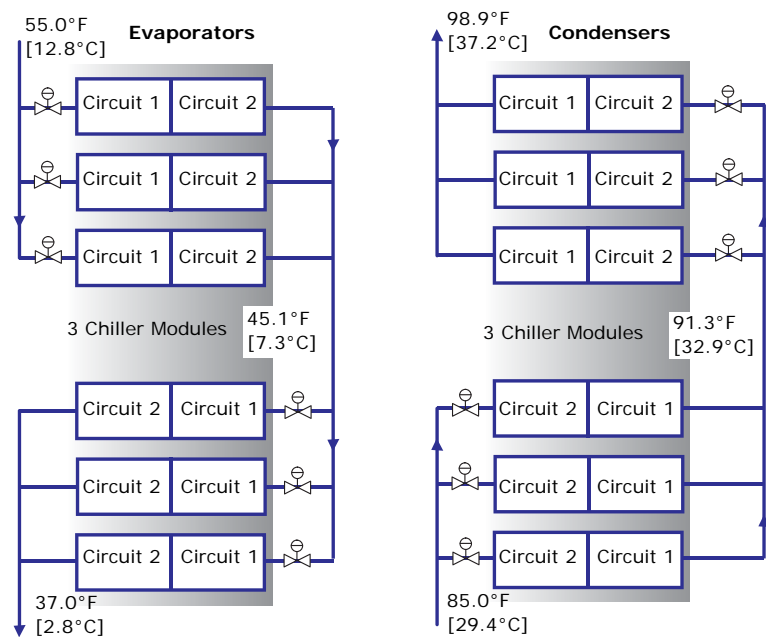

Unequal Chiller Sizing

Many designers seem to default to using the same capacity chillers within a chilled-water plant.^{25, 26} There are benefits to using unequally-sized chillers to meet the system loads. One is that when a chiller is brought online, so is its ancillary equipment, thus increasing *system* energy consumption. In general, the smaller the chiller, the smaller the ancillary equipment. Another is being able to ensure that chillers are efficiently loaded. Many times this can be accomplished by using chillers that do not have the same capacity. Examine the use of 60/40 splits (one chiller at 60 percent of system capacity, the other at 40 percent) or 1/3–2/3 splits (one chiller at 1/3 of system capacity the other at 2/3). The benefit is that the system load can be more closely matched with the total chiller capacity, increasing total system efficiency by eliminating the operation of chillers and ancillary equipment for more hours of the year. One caveat for variable-primary-flow systems is that if the pressure drops are different across the unequally sized chillers, they will load even more unequally without the use of pressure-reducing valves that require extra pump energy, as shown in Table 15 on page 61.

System Issues and Challenges

Low ΔT Syndrome

For many years the “low ΔT syndrome” debate has raged.^{27, 28} The symptom of the problem is that, in large systems, return-water temperature is too low, thus not allowing the chillers to fully load. Many system operators simply turn on more pumps and chillers to satisfy flow requirements, which wastes energy. For primary-secondary systems, some system designers advocate putting a check valve in the bypass line—thus putting chilled-water primary and secondary pumps in series and varying the flow through chiller evaporators. Other designers install primary pumps that are larger than necessary and “over pump” chillers at part-load conditions. These solutions are all “band-aids” and do not treat the source of the problem. Coad¹⁴ points to the fact that a properly operating hydraulic system will work as designed and explains the fallacies in the check valve and over pumping approaches. (Refer to the “Check valves” sidebar on page 46.) Taylor²⁹ recommends that a number of mitigating procedures be implemented to eliminate the problem. They include:

- Eliminating three-way valves
- Ensuring that airside control is not causing the problem
- Properly maintaining the system, including regular air filter changes, coil cleaning, control calibration, and proper setpoints

Before applying band-aid approaches in an attempt to “fix” symptoms such as low ΔT syndrome, ensure that the system is operating properly using some or all of the procedures Taylor²⁹ discusses. In addition to these procedures, simply reducing the chilled-water supply temperature will have the effect of raising the system return-water temperature in systems using two-way valves.

Amount of Fluid in the Loop

Two questions must be answered when determining how much fluid is necessary to maintain proper chilled-water-system control:

- How fast can the specific chiller respond to changing conditions?
- How fast can the system respond to changing conditions?

The amount of fluid the loop requires to operate properly is related to the larger of these two answers. Note that both answers describe an amount of time.

$$\text{Required Volume} = \text{Flow Rate} \times \text{Loop Time}$$

Where:

- Required Volume = the amount of fluid in the coil, pipes, evaporator barrel, storage tank, etc., in gallons [liters]

- Flow Rate = the system flow rate, in gpm [L/s]
- Loop Time = the time it takes for fluid to leave the chiller, move through the system, and return to the chiller, *allowing for stable system operation*, in minutes [seconds]

Chiller response to changing conditions

Follow the manufacturer's advice for the specific chiller being considered. This determines the absolute minimum amount of water the loop requires. However, this is the chiller minimum, not the system minimum, as discussed in the next section. Many of today's chillers have controls that respond quickly to changing conditions. Some chillers can react to a change in return water temperature in one minute; other chillers may require five or more minutes to react. The response varies, depending on chiller type and design.

System response to changing conditions

It is important to understand that even if a chiller can respond to rapidly changing conditions, the interaction between the chiller, system pumps, and control valves may define the minimum loop time. These components may "hunt" if the system conditions change too rapidly. Review these interactions to ensure that system control will be stable.

Example

A specific chiller requires at least two minutes of water in the loop to operate properly. However, after considering the system interaction, it's decided that a five-minute loop time will work best. The system design flow rate is 960 gpm [60.6 L/s].

$$\begin{aligned}\text{Required Volume} &= 960 \text{ gpm} \times 5 \text{ minutes} = 4,800 \text{ gallons} \\ &= 60 \text{ L/s} \times 5 \text{ minutes} \times (60 \text{ seconds}/1 \text{ minute}) = 18,180 \text{ liters}\end{aligned}$$

If the volume of fluid in the evaporator bundle, piping, and coils is less than the required volume, a tank should be added to increase loop volume. For optimal stability, the tank should be placed in the return water position and be designed to *mix* the returning-water stream with the water currently in the tank. In systems with no bypass, the tank may be placed in the supply chilled-water position.

Alternatively, the designer could:

- increase pipe sizes (increases system volume and reduces pump energy)
- design system for a lower flow rate (lowers required volume and reduces pumping energy, especially when same-sized pipes are used)

Contingency

Today, many organizations have contingency plans for critical areas of their business. Some deal with natural disasters and others with the loss of power in critical areas. However, few have actually taken the time to think about what a loss of cooling would mean to their facility. If the cooling system failed or was suddenly grossly undersized due to weather, etc., how would that affect business? What financial risk would be involved with a loss of cooling?

Cooling contingency planning is intended to minimize the losses a facility may incur as a result of a total or partial loss of cooling. It allows a building owner to act more quickly by having a plan in place and by proactively preparing his or her facility to accept temporary equipment. Although a number of facilities are prepared after the construction phase, the construction phase provides an easy and cost-effective opportunity to prepare a facility and is a logical time to provide water stub outs and electrical connections. This helps to keep costs down and reduces the need to shut down existing equipment to make necessary building preparations.

Cooling contingency planning is the process of preparing for a loss of cooling while in a non-emergency situation. This allows common sense, rather than panic, to prevail during a critical event. The following topics are general and broad in scope. They provide a sense of what is involved in the planning process. Contingency planning itself is very detailed and situation-specific.

Minimum capacity required

It is important to first identify the minimum capacity required. With multiple chillers in a facility, it may be acceptable to have less tonnage in an emergency situation. For example, a facility's chiller plant may consist of 1,800 tons [6,330 kW], but the minimum tonnage required may only be 1,200 tons [4,220 kW]. Therefore, it is also important to identify the plan of action if Chiller 1 fails, if Chiller 2 fails, if Chillers 2 and 3 fail, and so on.

Type and size of chiller

The type and size of contingency cooling required by a facility are determined by several factors. In turn, the choice of chiller determines how the facility is prepared. Examples of parameters that determine the chiller are:

- Electrical requirements
- Ease of installation (air-cooled chillers are easier to set up)
- Location or available space
- Comfort or process cooling

Location of equipment

Location can be a major factor in contingency planning. When selecting the location of the temporary equipment, it is important to consider:

- Water and electrical connections location
- Sound sensitive areas in the facility
- Location easily accessible to service staff
- Equipment separated from the public

Water and electrical connections

- Water connection size requirements
- External stub out locations
- Sufficient power to run the temporary unit
- Possible generator requirement

Ancillary equipment

- Pumping system requirements
- Temporary hose requirements
- Electrical cable requirements

This section briefly described some of the items to consider when establishing a cooling contingency plan. There may be other considerations, depending on the application. For information about failure recovery, see page 95.

Alternative Energy Sources

Energy source redundancy is receiving increased attention due to rate variations and reliability issues brought about by the deregulation of electrical utilities across the country. There are two basic approaches to meet these issues:

- Provide an alternate source of internally-generated electricity to serve a system in the event of general failure or an unacceptably high temporary cost of electricity (time-of-day or real-time rates).
- Provide an alternate source of chilled-water producing capability, possibly fueled by natural gas, another fossil fuel, or even using low cost electricity as an alternative energy source.

Electricity generation

The design, construction, and operation of full-capacity, electrical-generation systems is well understood. The electrical-generation capacity can be sized to allow an entire facility to operate or it can be sized for an emergency

situation. Electrical generation can be outsourced to avoid internal capitalization.

A variation of electrical generation uses an engine indirectly- or directly-coupled to a chiller. Either variation produces chilled water using an alternative fuel such as natural gas or fuel oil. The indirect-coupling method allows the chiller to operate using an alternative fuel or electricity from the grid. An engine directly-coupled to a chiller can only run using the alternative fuel.

Alternative fuel

Some designers prefer to employ chillers that use fossil fuels or perhaps renewable fuels. Examples are absorption chillers using natural gas, steam, hot water, landfill gas, biodiesel, or waste-to-energy boilers. Plants with these chillers, discussed in detail elsewhere³⁰, allow the owner to take advantage of expected fuel rate separations.

Thermal storage

Another successfully applied alternative-energy source is thermal storage. Chillers make either ice or chilled water during times of lower electricity costs. The energy is stored in tanks and then discharged to satisfy cooling loads during times of high electrical costs. Other manuals and an *Engineers Newsletter* describe the use of thermal storage in detail. **31, 32, 33, 34, 35**

Use any of these technologies to provide value to the building owner through judicious use of alternative fuels.

Plant Expansion

Plant expansion can be performed easily in either a primary–secondary or variable-primary-flow system by adding another chiller and pump to the system. The two major considerations will be whether the chilled-water distribution pipes will be able to handle the flow and how to install the new chiller while other chillers are still providing cooling. When the new system flow rate complies with good piping practice and the pumps can deliver the water, the process works well.

To maintain chilled-water flow during installation of a new chiller, some plants are constructed with piping stubs in place for the new chiller. In this way, the new chiller can be installed while the system is still operating, then the valves in the stubs can be opened.

When decoupled systems are used on large campus-type systems, added loads are often located some distance away from the original loads. Yet, planners like the idea of somehow hooking the new loads to the existing system. The “double-ended” system discussed in “Chiller sequencing in a double-ended decoupled system” on page 54 is one way of handling this requirement.

Retrofit Opportunities

A tremendous retrofit opportunity can be realized if the low-flow concepts discussed in the chapter “System Design Options” on page 27 are utilized. Building owners may need to increase the capacity of an existing system, for example, in response to a building addition. In many of these buildings, the condenser water system (piping, pump, and tower) is in good condition, but is considered to be too small. By changing from traditional design conditions, the existing infrastructure can often be used while still providing additional capacity. A detailed discussion of this starts on page 37.

Applications Outside the Chiller’s Range

Designers may wish to use chillers to provide cooling for which the flow rate or temperature requirements are not within the allowable ranges of a particular chiller, even though the chiller has adequate capacity. This often occurs with manufacturing processes. Let’s look at two examples showing *system* designs that can satisfy the desired conditions.

Flow rate out of range

A plastic injection molding process requires 80 gpm [5.1 L/s] of 50°F [10°C] water and returns that water at 60°F [15.6°C]. The selected chiller can operate at these temperatures, but has a minimum flow rate of 120 gpm [7.6 L/s]. The following system in Figure 51 can satisfy the process. Decoupling the chiller from the process load allows the water flow to be different, ensuring that the flow through the chiller is within acceptable limits. With a single chiller system, one pump and a three-way valve gives the same results.

Figure 51. Flow rate out of range for equipment

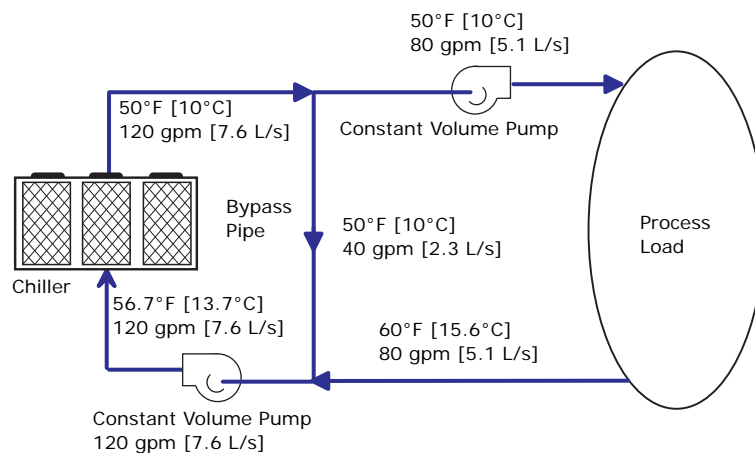

Temperatures out of range

A laboratory load requires 120 gpm [7.6 L/s] of water entering the process at 85°F [29.4°C] and returning at 95°F [35°C]. The accuracy required is more precise than the cooling tower can provide. The selected chiller has adequate capacity, but a maximum leaving-chilled-water temperature of 60°F [15.6°C].

Using a pair of bypass pipes allows the mixing valve to supply the proper temperature to the process load and maintains acceptable water flow rates and temperatures through the chiller. In the example shown in Figure 52, the chiller and process flow rates are equal, although this is not a requirement. For example, if the chiller had a higher flow rate, more water would bypass and mix with the warm return water.

Figure 52. Temperatures out of range for equipment

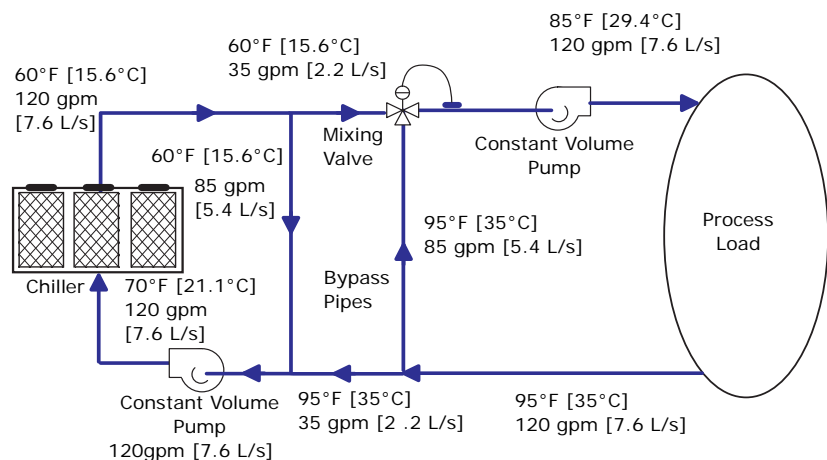

Precise temperature control

An example of a process application layout where the required temperature control tolerance is more precise than the chiller controls allow is shown in Figure 53.

For example, when Chiller 2 is turned on, it takes a certain amount of time to reach its supply-temperature setpoint. The dedicated control valve remains closed and water is bypassed until Chiller 2 reaches its setpoint, which keeps the water temperature supplied to the process within tolerance. When Chiller 2 reaches its setpoint, the control valve opens.

This design requires a different chiller-sequencing strategy than the standard decoupled system. Water must not be allowed to bypass from the return side to the supply side, since this will cause the temperature of the water supplied to the process to vary outside the tolerance. Set the system controls to turn on Chiller 2 before deficit flow occurs.

Figure 53. Precise temperature control, multiple chillers

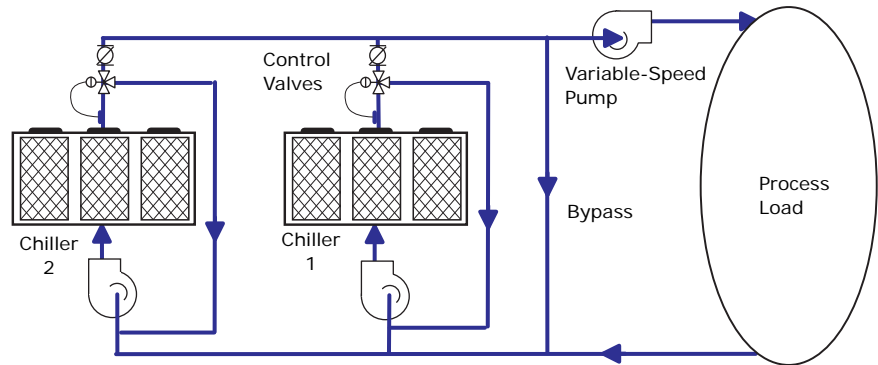

System Controls

Chilled-Water System Control

Chilled water reset—raising and lowering

Many chilled-water plants use chilled water reset, that is, the chiller's leaving-water temperature setpoint, in an effort to reduce chiller energy consumption. This can either be accomplished by the chiller controller or by the system controller.

Raising the chilled-water temperature reduces *chiller* energy consumption. In a constant-volume pumping system, this may reduce overall system energy consumption as long as humidity control is not lost. Humidity control may be lost if, as chilled-water temperature is increased, the air temperature leaving the coil increases to a point where it no longer performs adequate dehumidification.

In a variable-volume pumping system, however, raising the chilled-water temperature increases pump energy, often substantially, and typically increases total system energy. Before considering increased chilled-water temperature, the system operator should calculate the increased pumping energy and compare it with the chiller energy savings. It should be noted that ASHRAE/IESNA Standard 90.1–2007²⁰ requires chilled-water reset for constant-volume systems—with some exceptions—but exempts variable-volume systems from this requirement for the reasons discussed.

An often overlooked method of decreasing *system* energy consumption is to *reduce* the chilled-water temperature, thereby decreasing pumping energy but increasing chiller energy. This strategy is possible with adequate chiller capacity and lift capability. Reducing chilled-water temperature may also improve dehumidification in the building. Another result of reducing the chilled-water temperature is increased chiller capacity during times when the condenser water temperature is cooler than design. This allows more time before another chiller and its ancillary equipment are started.

Be aware that *any* change in chilled-water setpoint requires changes to be made to the system chiller-sequencing algorithms to ensure that system capacity is met. This added complication may not be warranted.

Chilled-water pump control

In constant flow systems, the pumps are either on or off, providing relatively constant flow when turned on. In practice, some flow variation will occur as system pressure drop changes. In a variable-flow system, pump control is most often performed by maintaining a pressure differential at a selected point in the system. For example, a variable-speed drive will increase its speed if the sensed pressure differential is too low, or slow down if the pressure differential is too

high. The control point is selected to minimize over-pressurizing the system and to assure adequate flow at all critical loads.

Critical valve reset (pump pressure optimization)

Often, pumps are controlled to maintain a constant-pressure differential at a remote coil. Unless this coil serves the zone requiring the most pressure (the critical zone), the pump provides more pressure than necessary and consumes more power than necessary. Systems that have integrated airside and chiller plant control systems and contain valves with direct digital controls present an opportunity for further pump operating-cost reduction. If a system is monitored to determine the critical valve at each point in time, the pump's operating pressure can be reset so that the critical zone's control valve is nearly wide open.

Integrated control allows a system-level controller to determine the critical zone and reset the pump's setpoint dynamically, therefore reducing pump operating costs.

Air-handler controllers know the position of their individual valves, which modulate to maintain the required water flow through the coil. The building automation system continually monitors the valve controllers, looking for the most open valve. The controller resets the pump setpoint so that at least one valve, the one requiring the highest inlet pressure, is nearly wide open. The result is that the pump generates only enough pressure to get the required water flow through this "critical" valve, thus saving pumping energy.

Addendum ak to ASHRAE 90.1-2007 now requires pump pressure for many chilled water systems. It will become part of 90.1-2010.

Number of chillers to operate

Some practitioners believe that operating more chillers at the same time permits each chiller to operate more efficiently. From a system perspective, this is rarely true. The chillers are not the sole energy consumers in the plant—activating a chiller also activates the condenser water pump, perhaps a chilled water pump, and tower fans. One analysis showed that if all operating chillers are equipped with variable frequency drives (VFDs), the only time it makes sense to run more chillers than necessary is if the condenser water drops below 65°F. Without VFDs on the chillers, the system never used less energy with the extra chiller operating.

Table 17. VFDs and centrifugal chillers performance at 90% load

ECWT	2 Chillers*	1 Chiller	Difference
85°F	306.4	268.0	-38.4
80°F	268.0	238.0	-30.0
75°F	230.8	210.6	-20.2
70°F	195.2	185.7	-9.5
65°F	160.3	164.3	+4.3

Note: Data shows only chiller power.
* Load equally divided.

If the chiller and tower capabilities are conducive to this strategy, the location and load profile determine if, when, and for how long the right conditions might occur. Determine the optimum control sequence for the *entire plant* by performing a detailed energy analysis of each component. Base the analysis on realistic load profiles and ambient conditions, and account for the energy used by all ancillary equipment.

For VPF systems, there will likely not be enough system flow to allow more chillers than necessary to operate without requiring bypass to stay above the chillers' minimum flows.

Condenser-Water System Control

Minimum refrigerant pressure differential

Every chiller requires a certain refrigerant pressure differential between the evaporator and condenser in order to operate. The chiller must develop its pressure differential within a manufacturer-specified time or its controls will shut it off. During some start-up conditions, this pressure differential may be hard to produce within the time limitation.

An example of such a condition is an office building that has been unoccupied during a cool, clear, fall weekend. The tower sump water is at 40°F [4.4°C]. Monday is sunny and warm, which requires a chiller to be turned on. Since the chiller is lightly loaded and the tower sump is large, the pressure differential cannot be reached before the chiller turns off. If the condenser flow rate for a given chiller can be reduced, this scenario is less likely to occur. The lower flow rate increases the leaving condenser-water temperature, which increases the condenser-refrigerant temperature and refrigerant pressure.

The flow reduction options include:

- Cooling tower bypass
- Chiller bypass
- One or two throttling valves in the condenser-water pipe with the pump riding its curve
- A variable-speed condenser water pump

After the minimum-pressure differential is reached, the flow may be increased as long as that minimum-pressure difference is maintained. Some designers and operators become concerned with possible fouling of condenser-water tubes during these start-up conditions. There is little to fear due to the short duration of reduced flow operation and the limited occurrences. The advantages and disadvantages of these options are discussed in a variety of publications.^{36,37}

Condenser-water temperature control

Cooling-tower-fan control

Cooling towers operate to produce a desired sump water temperature. As the heat rejection load and ambient wet-bulb temperature change, the cooling tower fans must move more or less air to produce the desired water temperature.

Cycling a single fan. Cycling a single fan on and off is one method to maintain rough water temperature control. Since airflow changes greatly between fan speeds, so does heat rejection. Temperature swings of 7°F to 10°F [3.9°C to 5.6°C] are not uncommon. Some chillers, especially older chillers with pneumatic controls, may operate poorly in response to these changing temperatures. Make sure that the fan does not cycle too often and damage the motor, drive, or fan assembly.

Two-speed fans. The installation of two-speed cooling tower fans is an option that reduces temperature swings. Typically, the low fan speed is between 50 and 70 percent of full speed. Since the heat rejection changes roughly in proportion with the fan speed, the temperature swing will be only 50 to 75 percent of cycling a single fan. Again, take care not to cycle too often between speeds—or the gear box may incur excessive wear and fail. A distinct advantage of two-speed fans is that at low speed, the fan power is greatly reduced. Since the fan power varies with the cube of the speed (approximately) the power at half speed is about 15 percent of full speed.

“Pony” motors. Another option offered by cooling-tower manufacturers is to have two separate motors available to drive the fan. The smaller motor is referred to as a “pony” motor. It operates at two-thirds of the full speed and uses about 30 percent of the full speed power. While controlling the tower, it is important to minimize cycling between speeds.

Variable-speed drives. Because the cost of variable-speed drives for cooling-tower fans has decreased, variable-speed drives have become more

prevalent than either two-speed fans or pony motors. Using variable-speed drives on cooling-tower fans offers two distinct benefits. First, the tower-water-temperature control is extremely good. Second, the fan power varies with the cube of the speed, so there is great potential for energy savings. Variable-speed drives also allow the fan speed to be changed without fear of gear box or motor wear. They may also offer acoustical advantages by significantly lowering sound power at reduced speeds. Variable-speed drives are also applicable to existing chilled-water systems.

Chiller-tower energy balance

The subject of condenser-water temperature control has been studied by a number of people. In recent years, Braun and Didderich³⁸; Hydeman, Gillespie, and Kammerud³⁹; and Schwedler⁴⁰ have all independently noted that balancing chiller and cooling-tower energy is important. Hydeman, et al., showed that at various loads and ambient conditions, the optimal condenser-water temperature for a specific chilled-water system depends on both chiller load and ambient conditions (see Figure 54). All the studies showed that during many points of operation, the optimal condition is *not* the lowest water temperature the cooling tower can produce. It is important for the system designer and operator to examine the use of system-level controls to set the tower-sump temperature setpoint to reduce the sum of chiller-plus-tower energy. This optimal chiller-tower control can be automated by a chiller-plant management system.

Figure 54. Chiller-tower energy consumption

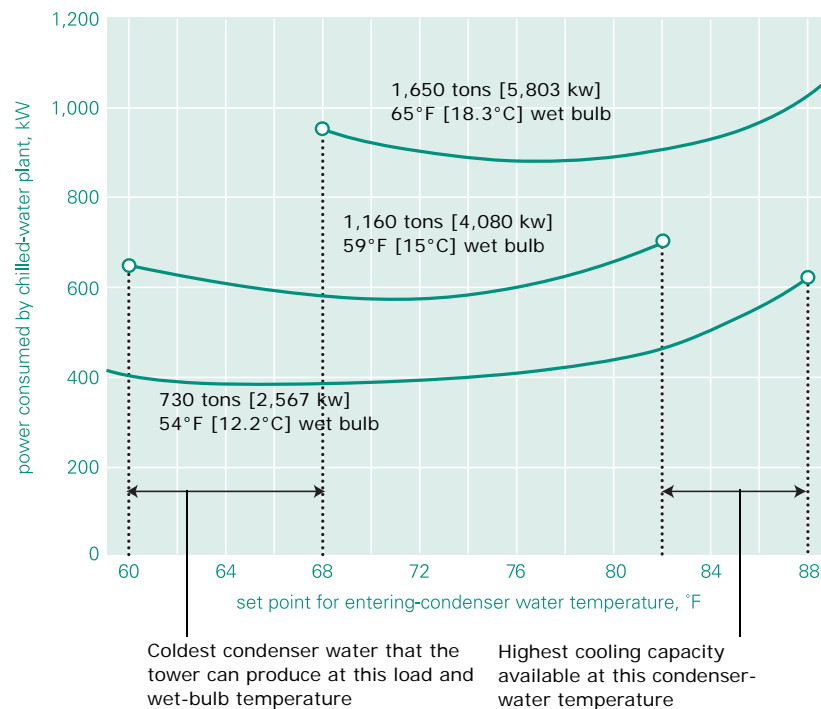

Figure 54 from Hydeman, et al., used with permission.

Variable condenser water flow

Chiller-tower-pump balance

There are times when a system designer may choose to vary the condenser water flow in addition to, or instead of, the cooling-tower fan speed. This may be beneficial in systems with high pumping power. If a variable-speed drive is installed, the flow may be reduced and the pump power can be reduced substantially—approximately with the cube of the speed. Attempting to vary both the pump and the tower fan speeds is complex and requires adequate time for design and implementation.

Keep the flow through the condenser above the minimum allowable flow rate for the chiller's condenser. The operator should regularly log the condenser approach temperature (the temperature difference between the condenser's refrigerant temperature and the condenser-water leaving temperature) to ensure that the tubes are not becoming fouled. The approach temperature may be monitored using a chiller plant management system.

Tower and/or tower nozzle design can affect the allowable condenser-water flow. If the flow drops below the manufacturer's specified limit, the water is no longer evenly distributed over the tower fill. This results in a decrease in cooling-tower heat-transfer effectiveness. In extreme cases, it can also result in water freezing in the cooling tower. If variable tower flow is a consideration, contact the cooling-tower manufacturer to determine the flow limit and possibly choose nozzles or cooling-tower configurations that can handle variable-water flow.

Most water-cooled, chilled-water systems use a constant condenser water flow rate. However, the condenser water flow rate can be varied between the minimum and maximum flows allowed for the specific chiller (refer to product catalog or selection program).

But reducing the condenser water flow rate affects the power consumption of the pumps, chiller, and cooling tower, as described below:

- **Condenser water pump:** Pump power is reduced because both the flow rate and the pressure drop through the piping and condenser are reduced.
- **Chiller:** Compressor power is increased because, as the flow rate decreases, the temperature of the water leaving the condenser increases. At a given load, this increases the compressor lift and, therefore, its energy use.
- **Cooling tower:** As explained above, the temperature of the water returning to the cooling tower is warmer. This increases the effectiveness of the heat exchanger. But the water flow rate is decreased, which can either improve or reduce the effectiveness of the cooling tower. So, for a given load, reducing the flow rate through the cooling tower sometimes decreases and sometimes increases energy use.

These three energy consumers must be balanced to minimize overall energy use. This makes varying condenser water flow complex, but the strategy below has been implemented on projects.

Control of the condenser water pumps and cooling tower fans is based on chiller load, which is calculated using the chilled-water flow rate and temperature differential. When the chiller load is less than 80 percent, the control system varies the speeds of both the cooling tower fan and condenser-water pump in proportion to chiller load, until the minimum allowable condenser-water flow rate is reached. As chiller load decreases further, the condenser-water pump remains at the minimum speed, while the cooling tower fan speed continues to decrease.

Figure 55. Effect of chiller load on water pumps and cooling tower fans

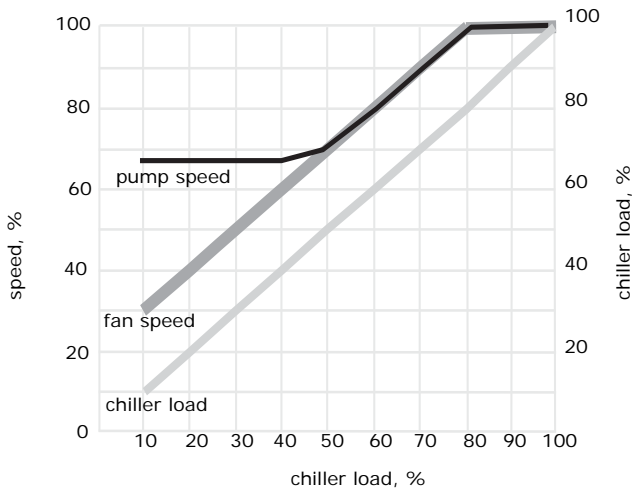

The June 2006 *ASHRAE Journal* article, "Prescription for Chiller Plants," (Baker, Roe, and Schwedler) details a chilled-water plant with variable-speed condenser water pumps.

The minimum allowable condenser water flow rate is the highest of the following:

- Minimum water flow rate required through the chiller condenser (consult chiller manufacturer)
- Minimum water flow rate required through the cooling tower fill (consult cooling tower manufacturer)
- Minimum water flow rate required to properly cool the pump motor (consult pump manufacturer)
- Minimum water flow rate that produces enough pressure to overcome the static lift from the base of the cooling tower to the top of the tower

Decoupled condenser-water system

To overcome possible problems with variable-water flow across a cooling tower, some designers decouple the condenser-water system as shown in Figure 56. This arrangement allows energy optimization through a reduction of pumping power without excessively complicating the system. Because cooling towers work best with full water flow over the transfer media, a

separate wetting (recirculation) pump provides a constant flow of water through the tower. This is a low-energy pump, as very little lift is required.

Dedicated, variable-flow condenser pumps (CDWP-1 and CDWP-2) permit a reduction in the pumping energy whenever the temperature of condenser water results in an unproductive reduction of condenser refrigerant pressure. While the number of dedicated pumps may seem complicated at first, remember the number of valves and controls that are eliminated.

Figure 56. Decoupled condenser-water system

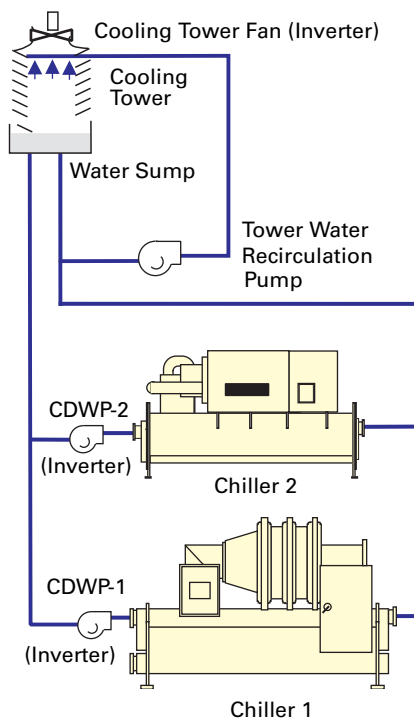

Failure Recovery

With all the varied approaches available to potential customers, it sometimes seems that the main idea gets lost. People purchase chilled-water plants to reliably produce chilled water to satisfy another need, such as comfort or process cooling. Therefore, when the plant operates there must be a process in place to recover from the failure of a chilled- or condenser-water pump, cooling tower, or chiller. Failure recovery should be integral to the chilled-water plant control system. Refer to Figure 57. If the control sequence tries to start Chiller 2 and its pump, but the pump has an electrical malfunction, the sequence should immediately lock out Chiller 2 and its pump. The control system should then automatically attempt to start Chiller 3 and its pump. At the same time, the control system should send a pump malfunction alarm to the system operator.

Figure 57. Failure recovery

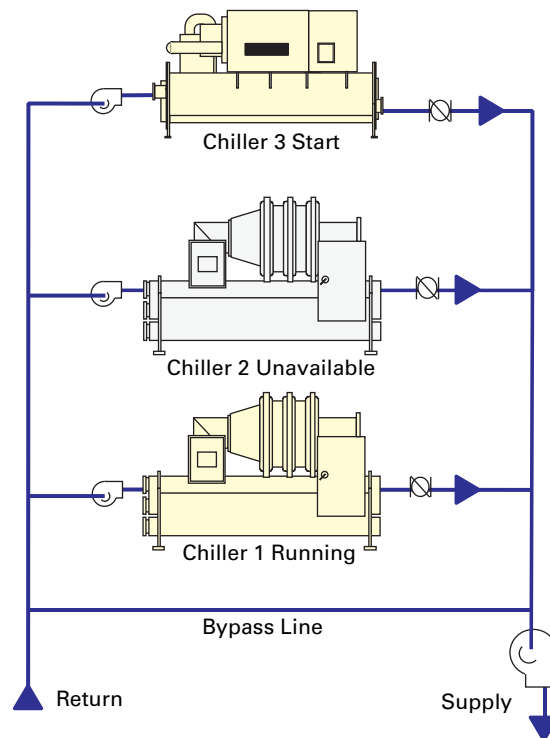

Conclusion

It is vital to have a clear understanding of chilled-water system concepts and their application. There is nothing particularly complex about the principles involved. Instead, system design is simply a matter of exercising a few key rules of applied physics.

A myriad of choices are available for the design and operation of chilled-water systems. These choices include flow rates, temperatures, system configurations, and control options. After determining the needs and wants of the building owner and chiller plant operator, judicious use of these choices allows designers to provide solutions that add real value. When applying the principles in this manual, it is important to remember the following rules:

Rule 1. Strive for simplicity. Simple does not always mean using the fewest components. Simplicity is usually elegant in its ability to be universally understood.

Rule 2. If the system designer can explain how a design works, there is a good chance that the system will function well. If the designer can't explain how the design works, there is *no* chance that the system will operate efficiently.

Rule 3. If the system operator understands the designer's explanation of how the system works, there is a good chance that the system will work. If the system operator doesn't understand the explanation, there is *no* chance that the system will operate efficiently.

Glossary

ASHRAE. American Society of Heating, Refrigerating, and Air-Conditioning Engineers (www.ashrae.org).

building automation system (BAS). A centralized control and monitoring system for a building.

chilled water. Also known as leaving-chilled-water or leaving-evaporator-water; chilled water is the cold water produced by the chiller (flowing through the tube bundle in the evaporator) and pumped to the air handler coils throughout the building. Within the evaporator, refrigerant surrounds the tube bundle and accepts heat from the return chilled water.

chiller. An air-conditioning system that circulates chilled water to various cooling coils in an installation.

coil. An evaporator or condenser made up of tubing either with or without extended surfaces (fins).

condenser. The region of the chiller where refrigerant vapor is converted to liquid so that the temperature and pressure can be decreased as the refrigerant goes into the evaporator.

condenser relief. The heat sink temperature difference from design outdoor air temperature for air-cooled equipment and design cooling water temperature for water-cooled equipment. This term is used to quantify the effect of condensing temperature on the power consumed by cooling equipment.

condenser water, leaving. *See* cooling water.

cooling tower water. *See* cooling water.

cooling water. Also known as tower water, leaving-cooling water, leaving-condenser water, entering-absorber water, condenser-absorber water, entering-cooling water, or cooling tower water; obtained from the source (tower, river, pond, etc.) to which heat is rejected, flows through the tubes that run through the absorber and the condenser, and is returned to the source.

In electrically driven chillers, the cooling water picks up heat only from the condenser. In an absorption chiller, the cooling water also has to pick up heat from the absorber. The water typically flows from the source at 85°F [29.4°C], first to the absorber and then to the condenser (series flow). Associated water temperatures are referred to as entering-absorber-water temperature (or leaving-tower-water temperature) and leaving-condenser-water temperature (or entering-tower-water temperature).

COP. Coefficient of Performance; cooling effect divided by heat input (dimensionless); the reciprocal of efficiency.

direct digital control. Programming used by building control systems to control variable outputs, such as valves or actuators. In the HVAC industry, DDC means direct digital control by a microprocessor controller with no intermediate device.

evaporator. The region in the chiller where the system chilled water is continuously cooled down by flashing the refrigerant to vapor in a deep vacuum as it picks up heat from the returning system water.

fouling. Deposits of foreign material in the water side of tubing in refrigeration condensers or chillers that affect the transfer of heat.

heat exchanger. A device used to transfer heat between two physically separated fluids.

heat transfer. The movement of heat from one body or substance to another. The three methods of heat transfer are conduction, convection, and radiation.

load. Any one of several output devices that are to be controlled by a building management panel.

mechanical-compression refrigeration cycle. The electrically driven chiller makes use of an electric motor, driving a compressor to produce chilled water for cooling. It does this via a mechanical process that uses a refrigerant for a working fluid. Inside the vessel are pressure and temperature differentials, where heat is absorbed at a low temperature and then rejected at a higher temperature.

psychrometric chart. A chart that shows the relationship between the temperature, pressure, and moisture content of the air.

psychrometric measurement. The measurement of temperature, pressure, and humidity of air using a psychrometric chart.

pumps (system)

chilled water. Circulates the chilled water through the evaporator section of the chiller and then through the building coils.

cooling water. Circulates the cooling water from the source through the chiller, condenser, and back to the source.

shell-and-tube. A designation for a type of heat exchangers consisting of a tube bundle within a shell or casing. Often used in chiller condensers and evaporators.

shell-and-tube flooded evaporators. Evaporators that use water flow through tubes built into a cylindrical evaporator with refrigerant on the outside of the tubes.

temperature, ambient. The temperature of the air surrounding the object under consideration.

temperature, wet-bulb. A measure of the degree of moisture in the air. It is the temperature of evaporation for an air sample, measured with a thermometer that has its bulb covered by a moistened wick.

tower water. *See* cooling water.

three-way valve. A flow-control valve with three fluid-flow openings. It controls constant flow through or around the load.

two-way valve. A flow-control valve with two fluid-flow openings.

valve, throttling. A small valve used primarily in gauge lines to shut off the line between readings, and to throttle the line to prevent fluctuations during readings.

References

- 1 Webb, R.L. and W. Li. "Fouling in Enhanced Tubes Using Cooling Tower Water, Part I: Long-Term Fouling Data." *International Journal of Heat and Mass Transfer* 43, no. 19 (October 2000): 3567-3578.
- 2 Schwedler, M. and B. Bradley. "An Idea for Chilled-Water Plants Whose Time Has Come...Variable-Primary-Flow Systems," *Engineers Newsletter* 28, no. 3 (1999), Trane.
- 3 American Society of Heating, Refrigerating, and Air-Conditioning Engineers. *ASHRAE HVAC Systems and Equipment Handbook*, Chapter 12, "Hydronic Heating and Cooling System Design" and Chapter 39, "Cooling Towers." ASHRAE, 2008.
- 4 American Society of Heating, Refrigerating, and Air-Conditioning Engineers. *ASHRAE Standard 147-2002: Reducing the Release of Halogenated Refrigerants from Refrigeration and Air-Conditioning Equipment and Systems*. ASHRAE, 2002.
- 5 Air-Conditioning, Heating, and Refrigeration Institute. *ARI Standard 550/590-2003: Performance Rating of Water Chilling Packages Using the Vapor Compression Cycle*. AHRI, 2003.
- 6 American Society of Heating, Refrigerating, and Air-Conditioning Engineers. *ASHRAE Guideline 22: Instrumentation for Monitoring Central Chilled-Water Plant Efficiency*. ASHRAE, 2008.
- 7 American Society of Heating, Refrigerating, and Air-Conditioning Engineers. *ASHRAE Standard 140-2007: Standard Method of Test for the Evaluation of Building Energy Analysis Computer Programs*. ASHRAE, 2007.
- 8 American Society of Heating, Refrigerating, and Air-Conditioning Engineers. *ASHRAE GreenGuide: The Design, Construction, and Operation of Sustainable Buildings*. 2nd ed. ASHRAE, 2006.
- 9 Air-Conditioning, Heating, and Refrigeration Institute. *ARI Standard 560-1992: Absorption Water Chiller and Water Heating Package*. AHRI, 1992.
- 10 Kelly, D.W. and T. Chan. "Optimizing Chilled-Water Plants." *Heating/Piping/Air Conditioning* (January 1999): 145-7.
- 11 Schwedler, M. and A. Nordeen. "Low Flow Works for Absorbers Too!" *Contracting Business* (November 1998): 108-112.
- 12 Demirchian, G.H. and M.A. Maragareci. "The Benefits of Higher Condenser-Water ΔT at Logan International Airport Central Chilled-Water Plant." *IDEA 88th Annual Conference Proceedings* (1997): 291-300.
- 13 Eley, C. "Energy Analysis—Replacement of Chillers for Buildings 43, 47, and 48." Eley Associates, CA, April 1997.
- 14 Coad, W.J. "A Fundamental Perspective on Chilled-Water Systems," *Heating/Piping/Air Conditioning* (August 1998): 59-66.

- 15 Bahnfleth, W. and E. Peyer. "Comparative Analysis of Variable and Constant Primary-Flow Chilled-Water-Plant Performance." *HPAC Engineering* (April 2001).
- 16 Houghton, D. "Know Your Flow—A Market Survey of Liquid Flow Meters." *E SOURCE Tech Update TU-96-3* (March 1996).
- 17 Taylor, S.T. "Primary-Only vs. Primary-Secondary Variable Flow Systems." *ASHRAE Journal* (February 2002).
- 18 Kreutzmann, J. "Campus Cooling: Retrofitting Systems." *HPAC Engineering* (July 2002).
- 19 Groenke, S. and M. Schwedler. "Series-Series Counterflow for Central Chilled Water Plants." *ASHRAE Journal* 44, no. 6 (June 2002): 23-29.
- 20 American Society of Heating, Refrigerating, and Air-Conditioning Engineers and the Illuminating Engineering Society of North America. *ASHRAE/IESNA Standard 90.1-2007: Energy Standard for Buildings Except Low-Rise Residential Buildings*. ASHRAE and IESNA, 2007.
- 21 Trane Applications Engineering Group. *Waterside Heat Recovery in HVAC Systems*. Applications Engineering Manual. Trane, 2003 (SYS-APM005-EN).
- 22 Schwedler, M. "Waterside Heat Recovery." *Engineers Newsletter* 36, no. 1 (February 2007), Trane. (ADM-APN023-EN)
- 23 Hanson, S. "Free Cooling Using Water Economizers." *Engineers Newsletter* 37, no. 3 (September 2008), Trane. (ADM-APM029-EN)
- 24 Landman, W. "Two Good Old Ideas Combine to Form One New Great Idea." *Engineers Newsletter* 20, no. 1 (1991), Trane.
- 25 Eppelheimer, D. and B. Bradley. "Chilled-Water Plants and...Asymmetry as a Basis of Design." *Engineers Newsletter* 28, no. 4, (October 1999), Trane.
- 26 Landman, W. and B. Bradley. "Off-Design Chiller Performance." *Engineers Newsletter* 25, no. 5 (December 1996), Trane.
- 27 Avery, G. "Controlling Chillers in Variable-Flow System." *ASHRAE Journal* (February 1998): 42-45.
- 28 Kirsner, W. "The Demise of the Primary-Secondary Pumping Paradigm for Chilled-Water Plant Design." *Heating/Piping/Air Conditioning* (November 1996).
- 29 Taylor, S.T. "Degrading Delta-T in New and Existing Chilled Water Plants." *Cool \$ense National Forum on Integrated Chiller Retrofits*, Lawrence Berkeley National Laboratory and Pacific Gas & Electric (September 1997).
- 30 Schwedler, M. and D. Brunsvold. *Absorption Chiller System Design*. Applications Engineering Manual. Trane, 1999. (SYS-AM-13)
- 31 Trane Applications Engineering Group. "Thermal Storage – Understanding Its Economics." *Ice Storage Systems, Engineered Systems Clinics*. Trane, 1991. (ISS-CLC- 1)

- 32 Trane Applications Engineering Group. "Thermal Storage – Understanding the Choices." Ice Storage Systems, *Engineered Systems Clinics*. Trane, 1991. (ISS-CLC-2)
- 33 Trane Applications Engineering Group. "Thermal Storage – Understanding System Design." Ice Storage Systems, *Engineered Systems Clinics*. Trane, 1991. (ISS-CLC- 3)
- 34 Trane Applications Engineering Group. "Thermal Storage–Understanding Control Strategies." Ice Storage Systems, *Engineered Systems Clinics*. Trane, 1991. (ISS-CLC-4)
- 35 Solberg, P. "Ice Storage as Part of a LEED® Building Design." *Engineers Newsletter* 36, no. 3. (September 2007), Trane. (ADM-APN025-EN)
- 36 Trane CenTraVac Group. "Condenser-Water Temperature Control for CenTraVac™ Centrifugal Chiller Systems." *Engineering Bulletin*. Trane, May 1997. (CTV-PRB006-EN)
- 37 Trane Engineers. "Water-Cooled Series R Chiller - Models RTHB & RTHC Condenser Water Control." *Engineering Bulletin*. Trane, August 1999. (RLC-EB-4)
- 38 Braun, J.E. and G.T. Diderrich. "Near Optimal Control of Cooling Towers for Chilled-Water Systems." *ASHRAE Transactions* 96, no. 2 (1990): 806-13.
- 39 Hydeman, M., K. Gillespie, and R. Kammerud. "CoolTools Project: A Toolkit to Improve Evaluation and Operation of Chilled Water Plants." *Cool Sense National Forum on Integrated Chiller Retrofits*. Lawrence Berkeley National Laboratory and Pacific Gas & Electric (September 1997).
- 40 Schwedler, M., and B. Bradley. "Tower Water Temperature–Control It How???" *Engineers Newsletter* 24, no. 1 (1995), Trane.

Index

A

- absorption refrigeration 98
- ASHRAE
 - GreenGuide 27, 29, 33
 - Guideline 22 25

B

- bypass flow control 63
- bypass locations 62
- bypass valve 8

C

- campus pumping arrangements 49
- centrifugal chiller capacity control 16
- check valves 46
- chilled water
 - flow rate 3, 27, 29
 - temperature 3, 27
- chilled-water distribution system 10
- chilled-water pump 10
- chilled-water pump control 87
- chilled-water reset 87
- chilled-water systems
 - configurations 42
 - control 87
 - large 22
 - mid-sized 21
 - overview 1
 - parallel arrangement 42
 - performance testing 24
 - plant expansion 83
 - series arrangement 44
 - series-counterflow 77
 - series-series counterflow 77
 - small 18
 - variations 70
 - water temperatures 28
- chiller range
 - applications outside 84
- chillers
 - centrifugal 16
 - number of 20
 - overview of 1
 - unequal sizing 78
- condenser 97
 - air-cooled 5
 - air-cooled vs water-cooled 5
 - flow rate 4, 29
 - free cooling or water economizer 70
 - water temperature 4, 29
 - water-cooled 4
- condenser-water pumping arrangements 14
- condenser-water system 13
- condenser-water system control 89
- condenser-water temperature control 90
- condenser-water temperatures 29
- condensing method 19
- configurations
 - parallel or series 20
- constant flow 19
- constant-flow system 12
- contingency plan 81
- control 15
 - flow-based 51

- controls
 - chilled-water system control 87
 - condenser-water system control 89
 - direct-digital 24
 - managing control complexity 21
 - programmable-logic 24
- cooling tower 13, 97
- cooling water 97
- cost implications 38

D

- dampers 9
- decoupled systems 45
 - condenser water system 93
 - double-ended 52
- distribution
 - pipng 11
 - pumps 48
- district cooling 22
- double-ended decoupled systems 52

E

- energy
 - alternative sources 82
- equalized loading 21
- evaporator 98
 - effect of chilled-water flow rate 3
 - effect of chilled-water temperature 3
 - overview 2

F

- face-and-bypass dampers 9
- failure recovery 95
- fans
 - single 90
 - two-speed 90
- flow
 - constant 19
 - standard rating flow conditions 29
 - variable 19
- flow measurement 62
- flow rates 27, 29
 - chilled water 3
 - guidance 27
 - low flow 34
 - misconceptions 39
 - selecting 30
- flow-based control 51
- fluid in the loop 79
- free cooling 70, 71

H

- heat exchanger 98
- heat recovery 70
- hydraulic decoupling 45

L

- lake water 72
- large chilled-water systems 22
- load
 - part-load operation 20
- loading
 - equalized 21
 - preferential 21, 73

loads
 overview 7
low ΔT syndrome 79
low flow
 cooling-tower options 34
 misconceptions 39

M

manifolded pumps 11, 14
mechanical-compression refrigeration 98
mid-sized chilled-water systems 21
minimum pressure differential 89
monitoring
 system efficiency 25
motors
 pony 90

P

parallel arrangement 73
parallel chillers 42
parallel configuration 20
part-load system operation 20
performance testing 24
pipe size 23
piping
 distribution 11
plant expansion 83
plate-and-frame heat exchanger 70
pony motors 90
preferential loading 21, 73
 series arrangement 76
pressure differential 89
primary-secondary systems 13, 45
production pumps 47
pumping arrangements 12, 14, 49
 campus 49
 common 49
 tertiary 49
pumps 98
 arrangements 12, 14, 49
 chilled water 10
 control 87
 distribution 48
 manifolded 11, 14
 production 47
 variable-speed 9

R

refrigerant migration 71
retrofit opportunities 37, 84
river water 72

S

sequencing options 21
series arrangement 76
series chillers 44
series configuration 20
series-counterflow application 77
series-series counterflow 77
sidestream arrangement 74
sidestream heat recovery 75
sidestream plate-and-frame heat exchanger 74
sizing
 unequal chiller sizing 78
small chilled-water systems 18

- standard rating flow conditions 29
- standard rating temperatures 28
- system configurations 42
- system control 87
- system controls 87, 89
- system design options 27
- system issues and challenges 79

T

- temperature
 - chilled water 3, 27, 28
 - condenser water 27, 29
 - control 85
 - out of range 85
 - standard rating 28
- tertiary pumping arrangements 49
- thermal storage 83
- three-way valve 8
- two-speed fans 90
- two-way valve 8

U

- unequal chiller sizing 78
- unit-level control 15

V

- valves
 - check valves 46
 - three-way valve 8
 - two-way valve 8
- variable condenser water flow 92
- variable flow 19
- variable primary flow
 - advantages of 56
 - chiller sequencing 63
 - guidelines 68
 - plant configuration 67
 - systems 13
- variable-speed drives 90
- variable-speed pump 9

W

- water economizer 70
- water temperatures 27, 28
 - coil response to 33
- well, river, or lake water 72
- wild coil 9



Trane
www.trane.com

For more information, contact your local Trane office or e-mail us at comfort@trane.com

Literature Order Number	SYS-APM001-EN
Date	May 2009
Supersedes	SYS-APM001-EN

Trane has a policy of continuous product and product data improvement and reserves the right to change design and specifications without notice.

Free Manuals Download Website

<http://myh66.com>

<http://usermanuals.us>

<http://www.somanuals.com>

<http://www.4manuals.cc>

<http://www.manual-lib.com>

<http://www.404manual.com>

<http://www.luxmanual.com>

<http://aubethermostatmanual.com>

Golf course search by state

<http://golfingnear.com>

Email search by domain

<http://emailbydomain.com>

Auto manuals search

<http://auto.somanuals.com>

TV manuals search

<http://tv.somanuals.com>