

Transition Networks
CPSMC0800-100
8-Slot *PointSystem*™ Chassis

User's Guide
(revision A)

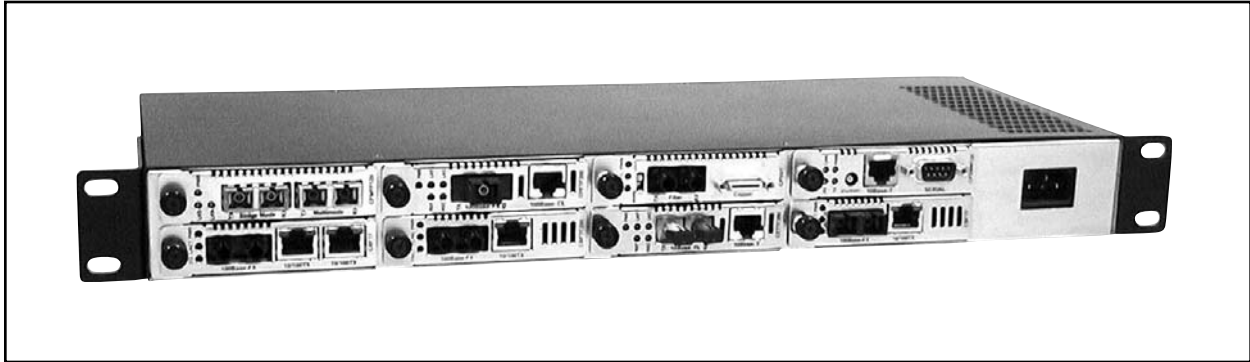

Compliance Information

UL Listed

C-UL Listed (Canada)

CISPR22/EN55022 Class A + EN55024

CE Mark

FCC Regulations

This equipment has been tested and found to comply with the limits for a class A digital device, pursuant to part 15 of the FCC rules. These limits are designed to provide reasonable protection against harmful interference when the equipment is operated in a commercial environment. This equipment generates, uses, and can radiate radio frequency energy and, if not installed and used in accordance with the instruction manual, may cause harmful interference to radio communications. Operation of this equipment in a residential area is likely to cause harmful interference, in which case the user will be required to correct the interference at the user's own expense.

Canadian Regulations

This digital apparatus does not exceed the Class A limits for radio noise for digital apparatus set out on the radio interference regulations of the Canadian Department of Communications.

Le présent appareil numérique n'émet pas de bruits radioélectriques dépassant les limites applicables aux appareils numériques de la class A & B prescrites dans le Règlement sur le brouillage radioélectrique édicté par le ministère des Communications du Canada.

European Regulations

Warning

This is a Class A product. In a domestic environment this product may cause radio interference in which case the user may be required to take adequate measures.

Achtung !

Dieses ist ein Gerät der Funkstörgrenzwertklasse A. In Wohnbereichen können bei Betrieb dieses Gerätes Rundfunkstörungen auftreten, in welchen Fällen der Benutzer für entsprechende Gegenmaßnahmen verantwortlich ist.

Attention !

Ceci est un produit de Classe A. Dans un environnement domestique, ce produit risque de créer des interférences radioélectriques, il appartiendra alors à l'utilisateur de prendre les mesures spécifiques appropriées



CAUTION: THE RJ CONNECTORS ON THE INDIVIDUAL MEDIA CONVERTER SLIDE-IN-MODULES ARE NOT INTENDED FOR CONNECTION TO THE PUBLIC TELEPHONE NETWORK. Failure to observe this caution could result in damage to the public telephone network.

Der Anschluss dieses Gerätes an ein öffentliches Telekommunikationsnetz in den EG-Mitgliedstaaten verstößt gegen die jeweiligen einzelstaatlichen Gesetze zur Anwendung der Richtlinie 91/263/EWG zur Angleichung der Rechtsvorschriften der Mitgliedstaaten über Telekommunikationsendeinrichtungen einschliesslich der gegenseitigen Anerkennung ihrer Konformität.

Trademark Notice

All trademarks and registered trademarks are the property of their respective owners.

Copyright Restrictions

© 2003 Transition Networks.

All rights reserved. No part of this work may be reproduced or used in any form or by any means – graphic, electronic, or mechanical – without written permission from Transition Networks.

Printed in the U.S.A.

33270.A

Table of Contents

1	Introduction	4
1.1	Description	4
1.2	Unpacking the CPSMC0800-100 Equipment	5
2	Slide-in-Modules	6
2.1	Media Converter Slide-in-Modules	6
2.1.1	Calculating Power Consumption	6
2.1.2	Installing Media Converter Slide-in-Modules	7
2.1.3	Replacing Media Converter Slide-in-Modules	8
2.2	Management Modules	9
2.2.1	Three Types of Management Modules	9
2.2.2	Installing the Management Modules	10
2.2.3	Replacing the Management Modules	11
3	Powering the CPSMC0800-100	12
3.1	Primary Power Supply	12
3.2	Auxilliary Power Supply	13
4	CPSMC0800-100 Chassis	14
4.1	Installing the CPSMC0800-100 Chassis	14
4.1.1	Standard 19-Inch Rack Installation	14
4.1.2	Table-Top Installation	15
4.2	Cascade Option	16
4.3	Connecting the Slide-in-Modules to the Network	17
4.4	Operation	18
5	SNMP Agent in the Management Module	19
5.1	SNMP Hardware Connections	19
5.2	SNMP Software	20
6	Fault Isolation and Correction	21
	Technical Specifications	22
	Cable Specifications	23
	Contact Us	24
	Warranty	25

1 Introduction

1.1 Description

The Transition Networks *PointSystem*™ CPSMC0800-100 is a 19-inch, rack-mountable chassis for selected Transition Networks Media Converter Slide-In-Modules. The CPSMC0800-100 allows the network administrator to connect various copper and fiber-optic network media over protocols that include Ethernet™, Fast Ethernet™, DS3/E3, and OC-12. The CPSMC0800-100 provides installation space for up to eight (8) single-slot or four (4) dual-slot Media Converter Slide-in-Modules in the front of the unit.



The CPSMC0800-100 also comes equipped with an AC or DC power supply. An optional AC or DC power supply with Instant Fail Over operation is also available. The primary power supply is accessed through the Power Inlet on the front panel, while auxiliary power is accessed through the Auxiliary Power Inlet, located on the back panel.

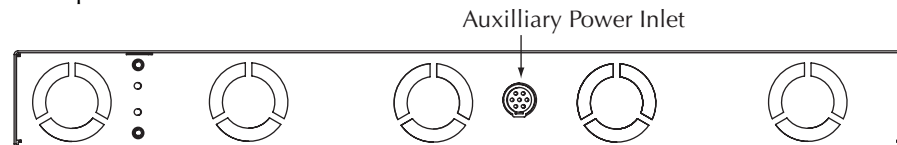

Four fans, two for the power supplies and two for the Slide-In-Modules, help remove heat from the chassis.

With installed *PointSystem*™ Management Module(s) (TN part number CPSMM-120, -200, or -210), the CPSMC0800-100 can be managed and monitored via:

- An SNMP application such as Transition Networks *FocalPoint*™ management software installed at a remote Network Management Station (NMS).
- A remote Web browser.
- A command-line interface (CLI) at an attached terminal.
- A command-line-interface (CLI) at a remote Telnet connection.

The management features include:

- Power control (slot on, slot off, in rush limit) for each individual slot.
- Internal temperature monitor.
- Fan failure monitor.
- Chassis power consumption monitor.
- Power supply type identification.
- Power supply condition monitor.
- Fail-over power detection.

The Management Modules also make it possible to control up to eight (8) cascaded CPSMC0800-100 chassis, which can accommodate up to 55 installed Media Converter Slide-in-Modules.

2.1 Unpacking the CPSMC0800-100 Equipment

Use the following list to verify the shipment:

Item	Part Number
8-Slot chassis with AC power supply	CPSMC0800-100
8-Slot chassis with DC power supply	CPSMC0810-100
Power Cord	(varies by country)
External AC Power Supply	CPSMP-180 (optional)
External DC Power Supply	CPSMP-190 (optional)
1-slot Master Management Module	CPSMM-100 (optional)
2-slot Master Management Module	CPSMM-200 (optional)
FocalPoint™ Software Disk	FPS (provided with CPSMM-200)
Expansion Management Module	CPSMM-210 (optional)
Management Module Cascade Connector	6026 (optional)
Rack Mount Ears	CPSRE-238 (optional)
Selectable Media Converter Slide-in-Module(s)	(various P/N) - (optional)
User's Guide	33270

2 Slide-in-Modules

2.1 Media Converter Slide-in-Modules

Transition Networks Media Converter Slide-in-Modules, installed in slots at the front of the chassis, allow the network administrator to connect various copper and fiber-optic network media over protocols that include Ethernet, Fast Ethernet, DS3/E3, and OC-12 as well as many others (see www.transition.com for a complete listing.)

NOTE: Refer to the documentation that comes with each Media Converter Slide-in-Module for cable, connector, and LED indicator information specific to that Media Converter Slide-in-Module.

2.1.1 Calculating the Power Consumption

CAUTION: Before installing the Media Converter Slide-in-Modules, refer to the power consumption data for each individual Media Converter Slide-in-Module (provided in the User's Guide shipped with each Media Converter Slide-in-Module). The combined power consumption of all devices must not exceed the available power supply. Failure to observe this caution could result in diminishing system reliability.

In other words, the combined wattage of the CPSMC0800-100 8-Slot chassis *plus* all Slide-In-Modules must be *less than* the available power.

Contact Transition Networks Tech Support to ensure the power requirements for your specific application do not exceed the available power.

2.1.2 Installing the Media Converter Slide-in-Modules

CAUTION: Wear a grounding device and observe electrostatic discharge precautions when installing the Media Converter Slide-in-Module(s) into the chassis. Failure to observe this caution could result in damage to, and subsequent failure of, the Media Converter Slide-in-Module(s).

NOTE: Media Converter Slide-in-Modules can be installed in any installation slot, in any order.

To install the Media Converter Slide-in-Module into the CPSMC0800-100 8-Slot chassis:

1. Remove the Media Converter Slide-in-Module protective plate from the installation slot by removing the one (1) screw that secures the plate to the front of the chassis.

NOTE: If the Slide-in-Module requires two slots, remove the protective plates from two (2) adjacent installation slots.

2. Align the Media Converter Slide-in-Module with the chassis installation slot so that the panel fastener screw is at the left of the Media Converter Slide-in-Module.

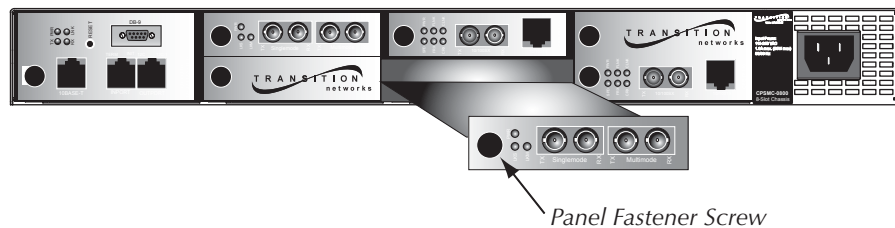

3. Carefully slide the Media Converter Slide-in-Module into the installation slot.

NOTE: Ensure that the Media Converter Slide-in-Module is firmly seated against the back of the chassis.
4. Install the Media Converter Slide-in-Module by carefully rotating the attached panel fastener screw clockwise to secure the Media Converter Slide-in-Module to the chassis.
5. Repeat steps 1 through 4 for additional Media Converter Slide-in-Module(s).

2.2.3 Replacing the Media Converter Slide-in-Modules

CAUTION: Wear a grounding device and observe electrostatic discharge precautions when replacing Media Converter Slide-in-Module(s). Failure to observe this caution could result in damage to, and subsequent failure of, the Media Converter Slide-in-Module(s).

NOTE: The Media Converter Slide-in-Modules are hot-swappable.

To replace a Media Converter Slide-in-Module:

1. Remove the Media Converter Slide-in-Module to be replaced by loosening the one (1) screw that secures the Slide-in-Module to the CPSMC0800-100 chassis front. Slide the Media Converter Slide-In-Module from the CPSMC0800-100 chassis.
2. Align the replacement Media Converter Slide-in-Module with the chassis installation slot so that the panel fastener screw is to the left.

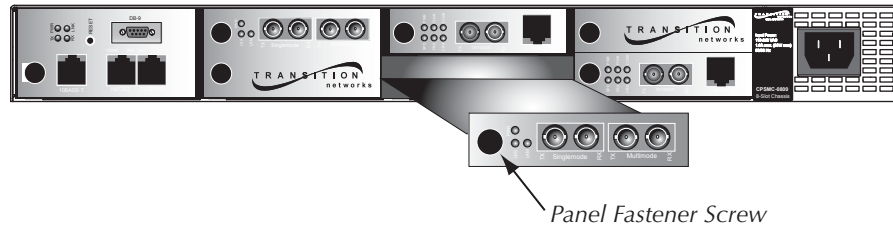

3. Carefully slide the replacement Media Converter Slide-in-Module into the installation slot.

NOTE: Ensure that the Media Converter Slide-in-Module is firmly seated against the back of the chassis.

4. Install the replacement Media Converter Slide-in-Module by carefully rotating the attached panel fastener screw clockwise to secure the Media Converter Slide-in-Module to the chassis.

2.2 Management Modules

Optional network management is provided by SNMP software embedded in Transition Networks *PointSystem™* Management Module(s) that can be installed in the CPSMC0800-100 8-Slot chassis.

Transition Networks provides two such modules:

- CPSMM-120 Single-Slot Master Management Module.
- CPSMM-200 Dual-Slot Master Management Module.

Along with an additional expansion module:

- CPSMM-210 Single Slot Expansion Management Module

2.2.1 Three Types of Management Modules

CPSMM-120 Single-Slot Master Management Module

The optional CPSMM-120 Single-Slot Master Management Module can be installed to enable network management of a single CPSMC0800-100 8-Slot chassis .

Refer to the CPSMM-120 User Guide for more information on the CPSMM-120 Single-Slot Master Management Module.

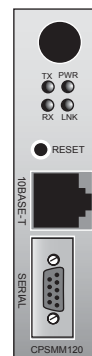

CPSMM-200 Dual-Slot Master Management Module

The optional CPSMM-200 Dual-Slot Master Management Module can also be installed in the CPSMC0800-100 8-Slot chassis to enable network management.

This module has all of the features of the CPSMM-120 plus a pair of cascade ports, which allow multiple *PointSystem* chassis to be connected. See section 4.3 *Cascade Option* for details on connecting multiple chassis.

Note also that this module requires **two** adjacent slots in the CPSMC0800-100 8-Slot chassis for installation.

Refer to the CPSMM-200/-210 User Guide for more information on the CPSMM-200 Dual-Slot Master Management Module.

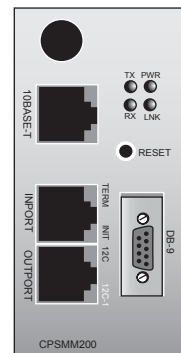

CPSMM-210 Single-Slot Expansion Management Module

The CPSMM-210 is used with the CPSMM-200 to connect up to eight (8) *PointSystem™* chassis into one manageable stack. See section 4.3 *Cascade Option* for details.

Refer to the CPSMM-200/-210 User Guide for more information on the CPSMM-210 Single-Slot Expansion Management Module.

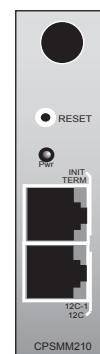

slide-in-modules

2.2.2 Installing the Management Modules

CAUTION: Wear a grounding device and observe electrostatic discharge precautions when installing the Management Module(s) in the 8-Slot chassis. Failure to observe this caution could result in damage to, and subsequent failure of, the Management Module.

Install one (1) Master Management Module (CPSMM-120 or CPSMM-200) in the primary managed CPSMC0800-100 8-Slot chassis.

If several *PointSystem*™ chassis are to be connected in a cascade fashion (see section 4.3 *Cascade Option*):

- Install one (1) Master Management Module (CPSMM-120 or CPSMM-200) into the primary managed CPSMC0800-100 8-Slot chassis.
- Install one (1) Master Management Module (CPSMM-200) or one (1) Expansion Management Module (CPSMM-210) in any secondary managed CPSMC0800-100 8-Slot chassis.

NOTE: Though the Management Module(s) can be installed in any *PointSystem*™ chassis slot, use of the left-most installation slot(s) for installing the Management Module(s) is recommended in order to keep the cascading cables separate from the network cables connected to the installed on Media Converter Slide-In-Modules.

To install a Management Module:

1a. CPSMM-200 Dual-Slot Master Management Module:

Remove two (2) Management Module protective plates from two (2) installation slots at the far-left position by removing the one (1) screw that secures each protective plate to the *PointSystem*™ chassis.

1b. CPSMM-120 Single-Slot Master Management Module OR CPSMM-210 Single-Slot Expansion Management Module:

Remove one (1) Management Module protective plate from one (1) installation slot at the far-left position by removing the one (1) screw that secures the protective plate to the *PointSystem*™ chassis.

2. Align the Management Module with the *PointSystem*™ chassis installation slot so that the panel fastener screw is to the left of the Management Module.

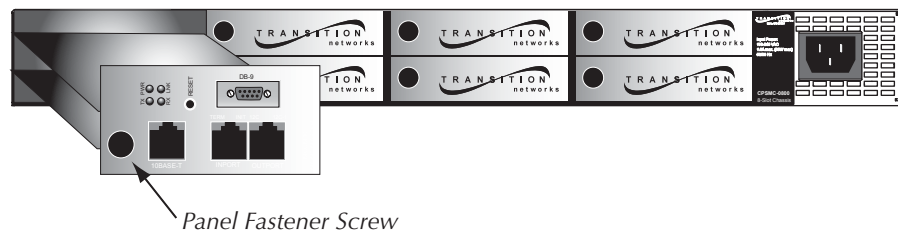

3. Carefully slide the Management Module into the installation slot, aligning the Management Module with the installation guides.

NOTE: Ensure that Management Module is firmly seated against backplane.

4. Rotate the attached panel fastener screw clockwise to secure the Management Module to the *PointSystem*™ chassis.

2.2.3 Replacing the Management Modules

CAUTION: Wear a grounding device and observe electrostatic discharge precautions when replacing Media Converter Slide-in-Module(s). Failure to observe this caution could result in damage to, and subsequent failure of, the Management Module(s).

NOTE: The Management Modules are **NOT** hot-swappable.

To replace a Management Module:

1. Remove the Management Module to be replaced by loosening the one (1) screw that secures the Management Module to the CPSMC0800-100 chassis front. Slide the Management Module from the CPSMC0800-100 chassis.
2. Align the replacement Management Module with the installation slot so that the panel fastener screw is at the top.

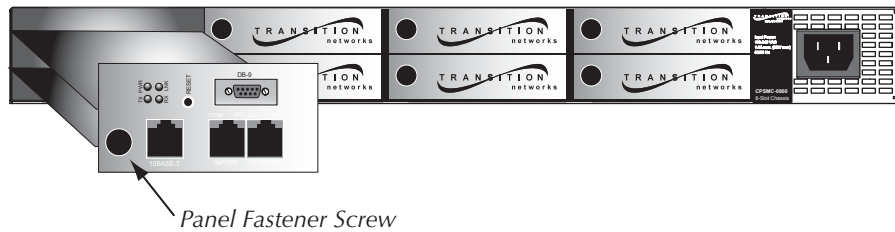

3. Carefully slide the replacement Management Module into the installation slot.

NOTE: Ensure that the Management Module is firmly seated against the back of the chassis.

4. Install the replacement Management Module by carefully rotating the attached panel fastener screw clockwise to secure the Management Module to the chassis.

slide-in-modules

3 Powering the CPSMC0800-100

The CPSMC0800-100 chassis can be powered through an AC or DC Power Supply. An optional auxilliary power supply, with Instant Fail Over protections, is also available.

NOTE: The CPSMC0800-100 8-Slot chassis does not have an ON/OFF switch.

- Power up the chassis by connecting the power supply.
- Power-down the chassis by disconnecting power supply.

WARNING: THE AC AND DC POWER SUPPLIES CONTAIN NO USER-SERVICABLE PARTS. DO NOT ATTEMPT TO SERVICE EITHER POWER SUPPLY. FAILURE TO OBSERVE THIS CAUTION COULD RESULT IN EQUIPMENT DAMAGE AND/OR PERSONAL INJURY OR DEATH.

NOTE: Contact Technical Support for any questions concerning power supply.

3.1 Primary Power Supply

The CPSMC0800-100 includes an internal power supply, which is accessed through a power inlet on the front panel. The power cord is included.

To power the CPSMM0800-100 8-Slot chassis through the Primary Power Supply:

1. Connect the female end of the power cord to the Power Inlet on the front panel of the chassis.
2. Plug the male end of the power cord into the correct voltage rack or wall socket.
3. Verify that the 8-Slot chassis is powered by observing the illuminated Power LEDs on the Slide-in-Modules and by the fan operation.

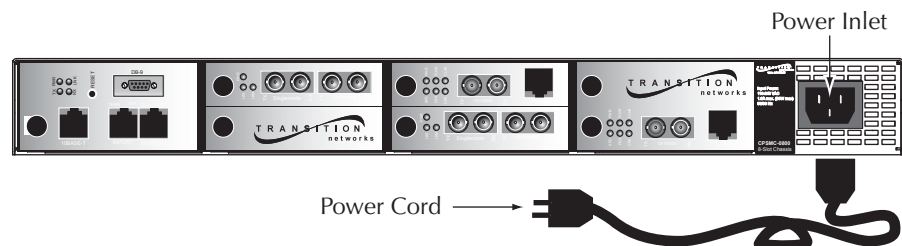

power supply

3.2 Auxilliary Power Supply

The CPSMC0800-100 can also be supplied with auxilliary power through the Auxilliary Power Inlet, located on the back panel. The External Power Converter and additional power cord are sold separately.

To power the CPSMM0800-100 8-Slot chassis through the Auxilliary Power Supply:

1. Connect the female end of the External Power Converter to the Auxilliary Power Inlet on the back of the 8-Slot chassis.
2. Connect the female end of the power cord to the male end of the External Power Converter.
3. Plug the male end of the power cord into the correct voltage AC rack or wall socket.
4. Verify that the chassis is powered by observing the illuminated Power LEDs on the Slide-in-Modules and by the fan operation.

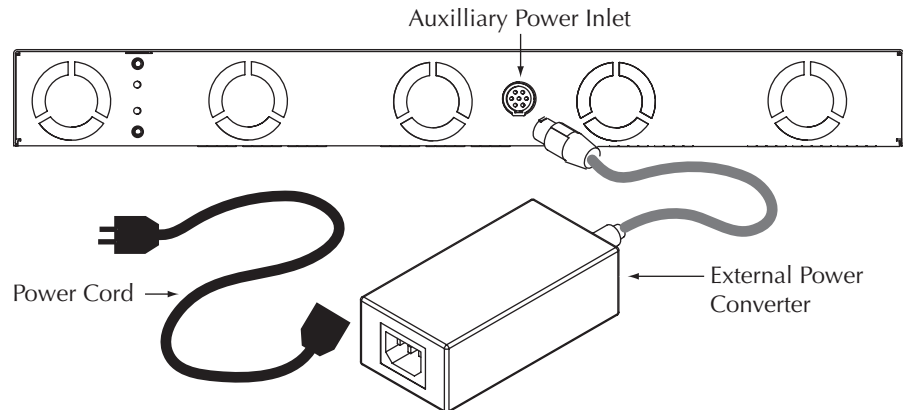

4 CPSMC0800-100 Chassis

4.1 Installing the CPSMC0800-100 Chassis

The CPSMC0800-100 can be installed in a standard 19-inch rack or on a table, shelf, or other stable surface.

4.1.1 Standard 19-inch Rack Installation

NOTE: The maximum recommended ambient temperature (T_{mra}) for the 8-Slot chassis is 40°C. If the 8-Slot chassis is installed in a closed or multi-unit rack assembly, the operating ambient temperature of the rack environment may be greater than room ambient. Consideration should be given to installing the 8-Slot chassis in an environment compatible with the T_{mra}.

CAUTION: Installation of the chassis in a rack should be such that the amount of air flow required for safe operation of the equipment is not compromised .

The 8-Slot chassis is designed so that the installation brackets can be installed to align the chassis either *flush* against the front or back edge of the rack or *recessed* from the front or back edge of the rack.

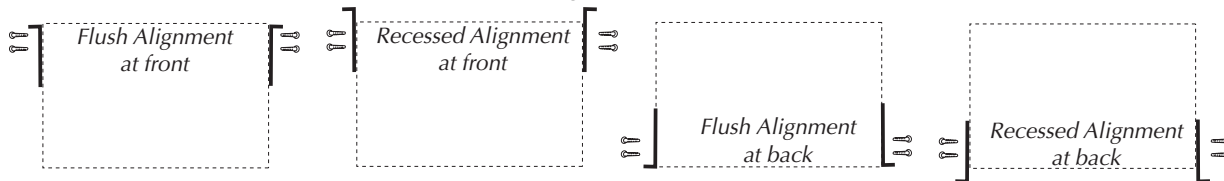

WARNING: SELECT MOUNTING BRACKET LOCATIONS ON THE CHASSIS THAT WILL KEEP THE CHASSIS BALANCED WHEN MOUNTED IN THE RACK. FAILURE TO OBSERVE THIS WARNING COULD ALLOW THE CHASSIS TO FALL, RESULTING IN EQUIPMENT DAMAGE AND/OR POSSIBLE INJURY TO PERSONNEL.

CAUTION: Consideration should be given to the connection of the chassis to the supply circuit and the effect that overloading of the circuits might have on over-current protection and supply wiring. Appropriate consideration of equipment nameplates should be used when addressing this concern.

CAUTION: Reliable earthing of rack-mounted equipment should be maintained. Particular attention should be given to supply connections other than direct connections to the branch circuit (e.g., use of power strips).

To install the CPSMC0800-100 8-Slot chassis into a standard 19-inch rack:

1. Determine the preferred alignment of the 8-Slot chassis in the rack.

NOTE: Installation bracket mounting screws are provided. Rackmount screws and clip nuts are NOT provided.

2. Locate six (6) installation bracket mounting screws (provided) for each chassis to be installed.

WARNING: Mount the chassis evenly and securely onto the rack. Failure to observe this warning could allow the chassis to fall, resulting in equipment damage and/or possible injury to personnel.

3. Align the universal mounting bracket in the selected position against the side of the chassis so that the chassis installation holes are visible through the universal bracket installation holes.
4. Using a Phillips screwdriver, install the three (3) screws through the mounting bracket into the installation holes on side of the chassis.



5. Repeat steps 3 and 4 for the second mounting bracket.
6. Locate four (4) screws (not provided) and optional clip-nuts (not provided) for each chassis to be installed.
7. Carefully align the chassis at a secure and level position between the 19-inch site rack mounting rails.
8. Install two (2) screws through the right bracket into the right mounting rail and two (2) screws through the left bracket into the left mounting rail, using the clip nuts to secure, if necessary.

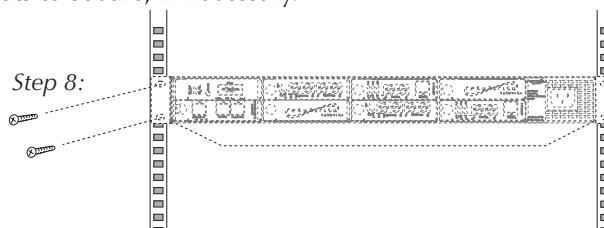

chassis

4.1.2 Table-Top Installation

The CPSMC0800-100 8-slot chassis is shipped with four (4) rubber feet for optional installation on a table or other flat, stable surface in a well-ventilated area. If table-top installation is desired, remove the rubber feet from the card and place one at each of the four corners on the bottom of the chassis.

4.2 Cascade Option

The Management Module cascade option allows the network administrator to connect up to eight (8) CPSMC0800-100 8-Slot chassis into one manageable stack, providing a single management source for up to 55 installed Media Converter devices.

To create the cascade option, the CPSMM-200 Dual Slot Master Management Module is installed in the first chassis in the series. The CPSMM-210 Single-Slot Expansion Management Module is installed in each subsequent chassis.

The CPSMM-200 Management Module is installed in the first chassis in the series

The CPSMM-210 Management Module is installed in each subsequent chassis

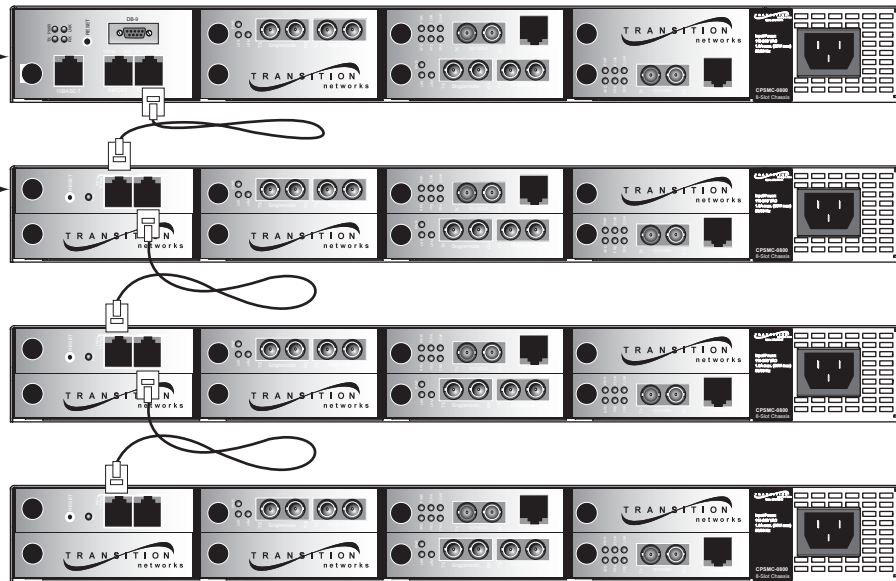

An alternative setup involves installing two CPSMC-200 Dual-Slot Master Management Modules into two adjacent chassis for redundant management.

The CPSMM-200 Management Module is installed in the first chassis in the series

Another CPSMM-200 Management Module is installed in the next chassis as a backup

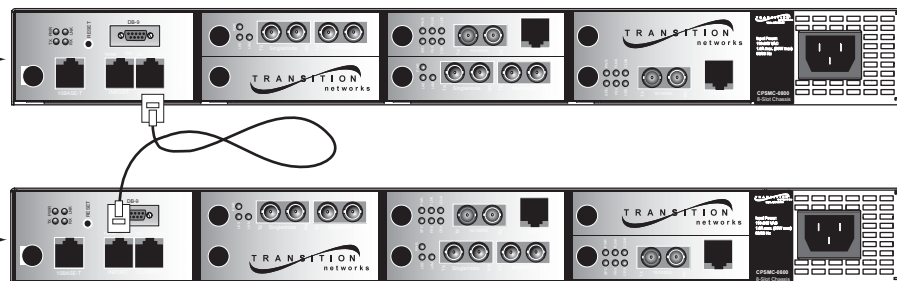

chassis

To cascade two or more CPSMC0800-100 8-Slot chassis:

1. Locate one (1) Transition Networks CPSMC0800-100 Management Module cascade cable (with RJ-45 connectors installed at both ends) for each set of two (2) chassis to be cascaded.

NOTE: Transition Networks Management Module cascade cables are one (1) meter long. Ensure that the chassis are installed within one (1) meter of each other.

2. At the first chassis in the series: Plug the RJ-45 connector at one end of the cascade cable into the Management Module's RJ-45 port labeled "OUTPUT".
3. At the next chassis in the series: Plug the RJ-45 connector at the other end of the cascade cable into the Management Module's RJ-45 port labeled "INPUT".
4. At the same chassis as in step 3: Plug the RJ-45 connector at one end of the cascade cable into the Management Module's RJ-45 port labeled "OUTPUT".
5. At the next chassis in the series: Plug the RJ-45 connector at the other end of the cascade cable into the Management Module's RJ-45 port labeled "INPUT".
6. Repeat steps 4 and 5 until all chassis have been connected.

4.3 Connecting the Slide-in-Modules to the Network

Once the CPSMC0800-100 chassis has been installed, the Media Converter Slide-in-Modules may be connected to the network.

CAUTION: Connect input/output network cables ONLY to Media Converter Slide-In-Module connectors within the same network protocol (such as Ethernet-to-Ethernet, Fast Ethernet-to-Fast Ethernet, ATM-to-ATM). Failure to observe this caution will cause data transfer to fail.

Refer to User's Guides included with the Media Converter Slide-In-Modules for cabling specifications and instructions.

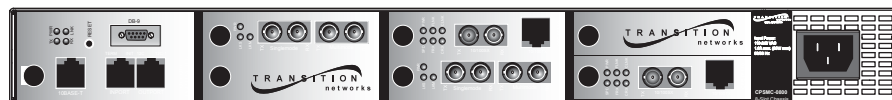

Check the individual User's Guides for specific information on how to connect each Slide-in-Module to the network.

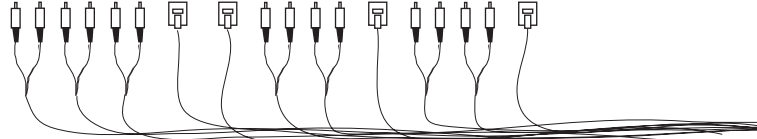

chassis

4.4 Operation

Daily operation of the CPSMC0800-100 8-Slot chassis requires no network administrator activity except for the occasional monitoring of the status LED indicators on the installed Media Converter Slide-In-Modules.

Each Media Converter Slide-in-Module and each Management Slide-in-Module has one or more LED indicators to help monitor the CPSMC0800-100 PointSystem™ chassis network.

Refer to the User's Guide included with each Transition Networks Slide-in-Module to interpret the LED indicators on the Management and Media Converter modules.

LED Indicators on the Management Module and Slide-in-Modules



5 SNMP Agent in the Management Module

Both Management Modules (CPSMM-120 and CPSMM-200) have an **SNMP** (Simple Network Management Protocol) Agent installed in the module that allows remote management of networked devices.

The SNMP agent includes the Transition Networks *PointSystem*™ **Command Line Interface** (CLI) and an embedded **Telnet server**.

These tools allow the network administrator to configure and manage the CPSMC0800-100 8-Slot from an attached terminal or from a remote, networked computer.

In addition, Transition Networks **FocalPoint**™ software can be installed in the networked computer to provide a graphical user interface to monitor the Conversion Center.

5.1 SNMP Hardware Connections

The SNMP software can be accessed either through the Management Module's DB-9 serial port or through the RJ-45 Ethernet™ port.

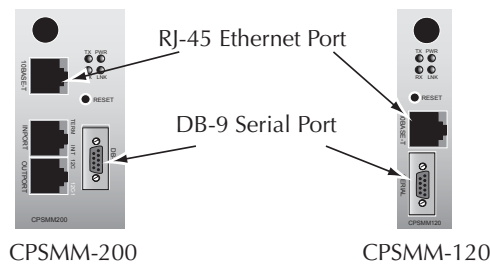

DB-9 Serial Port

The DB-9 serial port allows the network administrator to configure and manage the CPSMC0800-100 8-Slot chassis using the SNMP Command-Line Interface (CLI) at an attached terminal or terminal emulator.

Use a null modem cable to attach a terminal to the DB-9 serial port on the Management Module as shown.

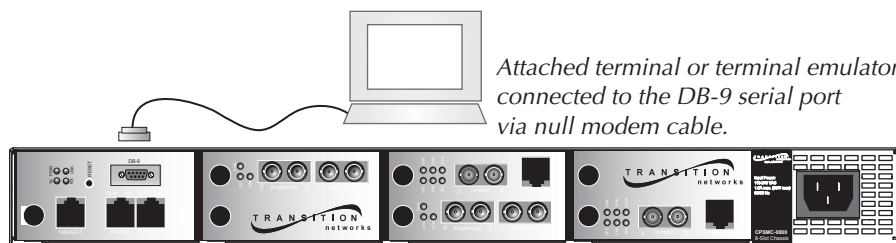

SNMP

RJ-45 Ethernet™ Port

The RJ-45 Ethernet™ Port allows the network administrator to manage the CPSMC1800-100 8-Slot chassis via a remote Network Management Station (NMS) in one of two ways:

1. Using the Transition Networks *FocalPoint*™ graphical user interface.
2. Using a remote Telnet connection.

Use an RJ-45 network cable to attach a terminal (via a network hub or switch) to the RJ-45 Ethernet™ port on the Management Module as shown.

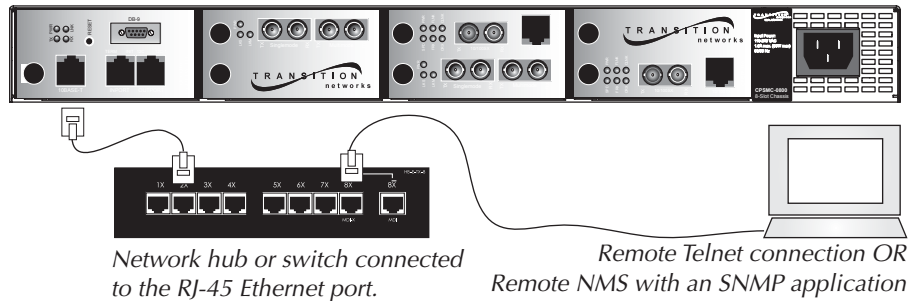

NOTE: To manage the *PointSystem*™ chassis via a remote NMS, both the RJ-45 Ethernet™ port and the NMS must be connected to a network with Internet accessibility.

5.2 SNMP Software

The SNMP software is described in a separate manual available from Transition Networks.

6 Fault Isolation and Correction

1. **Are ANY of the POWER LEDs on any of the Slide-in-Modules illuminated; AND/OR are the fans operating?**
YES
 - The chassis is receiving power. Proceed to the next step.**NO**
 - Ensure all power supply cables for proper connection.
 - Ensure the AC receptacle on the wall is supplying power.
 - If the fuse for the AC receptacle on the wall blows repeatedly, have the AC receptacle inspected by a qualified electrician.
 - Contact Tech Support: 1-800-260-1312, Int'l: 00-1-952-941-7600.

2. **Are ANY of the POWER LEDs on any of the Slide-in-Modules illuminated; but are the fans NOT operating?**
YES
 - The chassis is receiving power. Proceed to the next step.**NO**
 - Contact Tech Support: 1-800-260-1312, Int'l: 00-1-952-941-7600.

3. **For the Management Modules (CPSMM120, CPSMM200, CPSMM210), are ANY of the POWER LEDs NOT illuminated?**
NO
 - All Management Modules are receiving power. Proceed to the next step.**YES**
 For those Management Modules where the POWER LED is NOT illuminated:
 - Ensure the Management Module is firmly seated in the slot.
 - Press the RESET button on the Management Module.
 - Contact Tech Support: 1-800-260-1312, Int'l: 00-1-952-941-7600.

4. **For the remaining Slide-in-Modules, are ANY of the POWER LEDs NOT illuminated?**
NO
 - All Slide-in-Modules are receiving power. Proceed to the next step.**YES**
 For those Slide-in-Modules where the POWER LED is NOT illuminated:
 - Ensure the Slide-in-Module is firmly seated in the slot.
 - Contact Tech Support: 1-800-260-1312, Int'l: 00-1-952-941-7600.

5. **To determine if a fault is due to a software problem, consult the “Fault Isolation and Correction” section of the SNMP software manual available from Transition Networks.**

6. **To determine if a fault is due to an individual Management Module or Slide-in-Module, consult the “Fault Isolation and Correction” section of the User Guide for that particular Module.**

7. **If none of the solutions listed in this section resolves the problem, contact Technical Support: 1-800-260-1312, International: 00-1-952-941-7600.**

Technical Specifications

For use with Transition Networks Model CPSMC0800-100 or equivalent.

Product is certified by the manufacturer to comply with DHHS Rule 21/CFR, Subchapter J applicable at the date of manufacture.

Dimensions 17 x 10.4 x 1.8 inches (432 x 264 x 46 mm)

Shipping Weight 8 lbs. (3.6 kg)

Power Input 100-240VAC, 50/60Hz, 18-72VDC

Power Consumption 60 Watts*

*Refer to the power consumption data for each individual Media Converter Slide-in-Module (provided in the User's Guide shipped with the Media Converter) to determine optimum site configuration.

MTBF (Mean Time Before Failure)	MIL217F2 V5.0 (hrs)	Bellcore7 V5.0 (hrs)
without fans	43,277	114,896
with three (3) fans	22,972	61,715

Environment

Tmra*:	0 to 40°C (32° to 104°F)
Storage Temperature:	-40 to 80°C (-40 to 176°F)
Humidity	5 to 95%, non condensing
Altitude	0 to 10,000 feet

*Manufacturer's rated ambient temperature. Refer to the power consumption data for EACH model Media Converter Slide-in-Module (provided in User's Guide shipped with Media Converter Slide-in-Module) to determine optimum site configuration.

Compliance EN 55022 Class A; EN 55024; FCC Class A; UL Listed, CE Mark

Warranty Lifetime

CAUTION: Visible and Invisible Laser Radiation When Open. Do Not Stare Into Beam Or View Directly With Optical Instruments.

CAUTION: Use of controls, adjustments or the performance of procedures other than those specified herein may result in hazardous radiation exposure.

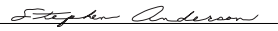
TRANSITION networks		DECLARATION OF CONFORMITY	
Name of Mfg:	Transition Networks	6475 City West Parkway, Minneapolis MN 55344 USA	
Model:	PointSystem™ Chassis		
Part Number:	CPSMC0800-100, CPSMC0810-100		
Regulation:	EMC Directive 89/336/EEC		
Purpose: To declare that the PointSystem™ Chassis to which this declaration refers is in conformity with the following standards.			
EN 55022:1994; EN 55024:1998; FCC Part 15 Class A; UL 1950; 21 CFR subpart J			
<i>I, the undersigned, hereby declare that the equipment specified above conforms to the above Directive(s) and Standard(s).</i>			
 Stephen Anderson, Vice-President of Engineering		April 1, 2003 Date	

Cable Specifications

Null Modem Cable

The Null Modem Cable is used for connecting a terminal or terminal emulator to the Management Module's DB-9 connector to access the command-line interface.

The table below shows the pin assignments for the DB9 cable.

Function	Mnemonic	Pin
Carrier Detect	CD	1
Receive Data	RXD	2
Transmit Data	TXD	3
Data Terminal Ready	DTR	4
Signal Ground	GND	5
Data Set Ready	DSR	6
Request To Send	RTS	7
Clear To Send	CTS	8

25 Pin RS-232 Null Modem Cable

Chassis Ground	1	—————	1	Chassis Ground
Transmit Data	2	—————	3	Receive Data
Receive Data	3	—————	2	Transmit Data
Request To Send	4	—————	4	Request To Send
Clear To Send	5	—————	5	Clear To Send
Data Set Ready	6	—————	20	Data Terminal Ready
Carrier Detect	8	—————	6	Data Set Ready
Data Terminal Ready	20	—————	8	Carrier Detect
Signal Ground	7	—————	7	Signal Ground

RJ-45 Cable

Category 5:

Gauge:	24 to 22 AWG
Attenuation:	22.0 dB /100m @ 100 MHz
Maximum Cable Distance:	100 meters

- Straight-Through OR Crossover cable may be used.
- Shielded Twisted-Pair(STP) OR Unshielded Twisted-Pair(UTP) may be used.
- All pin pairs (1&2, 3&6, 4&5, 7&8) are active in a Gigabit Ethernet™ network.
- Use only dedicated wire pairs for the active pins:
(e.g., blue/white & white/blue, orange/white & white/orange, etc.)
- Do not use flat or silver satin wire.

Contact Us

Technical Support

Technical support is available 7:00 AM - 6:00 PM CST (GMT -6:00)

United States: **1-800-260-1312**

International: **00-1-952-941-7600**

Transition Now

Chat live via the Web with a Transition Networks Technical Support Specialist.

Log onto **www.transition.com** and click the **Transition Now** link.

Web-Based Seminars

Transition Networks provides 12-16 seminars per month via live web-based training.

Log onto **www.transition.com** and click the **Learning Center** link.

E-Mail

Ask a question anytime by sending an e-mail message to our technical support staff.

techsupport@transition.com

Address

Transition Networks

6475 City West Parkway
Minneapolis, MN 55344, USA

telephone: 952-941-7600

toll free: 800-526-9267

fax: 952-941-2322

Warranty

Limited Lifetime Warranty

Effective for Products Shipped May 1, 1999 and After. Every Transition Networks' labeled product purchased after May 1, 1999 will be free from defects in material and workmanship for its lifetime. This warranty covers the original user only and is not transferable.

This warranty does not cover damage from accident, acts of God, neglect, contamination, misuse or abnormal conditions of operation or handling, including over-voltage failures caused by use outside of the product's specified rating, or normal wear and tear of mechanical components. If the user is unsure about the proper means of installing or using the equipment, contact Transition Networks' free technical support services.

To establish original ownership and provide date of purchase, please complete and return the registration card accompanying the product or register the product online on our product registration page.

Transition Networks will, at its option:

- Repair the defective product to functional specification at no charge,
- Replace the product with an equivalent functional product, or
- Refund the purchase price of a defective product.

To return a defective product for warranty coverage, contact Transition Networks' technical support department for a return authorization number. Transition's technical support department can be reached through any of the following means:

During regular business hours Monday-Friday, 7 AM – 6 PM CST (- 6:00 GMT), Contact Tech Support via:

- tel 800-260-1312 x 200 or 952-941-7600 x 200
- fax 952-941-2322
- email techsupport@transition.com
- live web chat: Transition NOW

Any Other Time:

- voice mail 800-260-1312 x 579 or 952-941-7600 x 579
- All messages will be answered within one hour.

Send the defective product postage and insurance prepaid to the following address:

CSI Material Management Center

c/o Transition Networks

508 Industrial Drive

Waconia, MN 55387 USA

Attn: RETURNS DEPT: CRA/RMA # _____

Failure to properly protect the product during shipping may void this warranty. The return authorization number must be written on the outside of the carton to ensure its acceptance. **We cannot accept delivery of any equipment that is sent to us without a CRA or RMA number.**

The customer must pay for the non-compliant product(s) return transportation costs to Transition Networks for evaluation of said product(s) for repair or replacement. Transition Networks will pay for the shipping of the repaired or replaced in-warrant-

ty product(s) back to the customer (any and all customs charges, tariffs, or/and taxes are the customer's responsibility).

Before making any non-warranty repair, Transition Networks requires a \$200.00 charge plus actual shipping costs to and from the customer. If the repair is greater than \$200.00, an estimate is issued to the customer for authorization of repair. If no authorization is obtained, or the product is deemed not repairable, Transition Networks will retain the \$200.00 service charge and return the product to the customer not repaired. Non-warranted products that are repaired by Transition Networks for a fee will carry a 180-day limited warranty. All warranty claims are subject to the restrictions and conventions set forth by this document.

Transition Networks reserves the right to charge for all testing and shipping incurred, if after testing, a return is classified as "No Problem Found."

THIS WARRANTY IS YOUR ONLY REMEDY. NO OTHER WARRANTIES, SUCH AS FITNESS FOR A PARTICULAR PURPOSE, ARE EXPRESSED OR IMPLIED. Transition NETWORKS IS NOT LIABLE FOR ANY SPECIAL, INDIRECT, INCIDENTAL OR CONSEQUENTIAL DAMAGES OR LOSSES, INCLUDING LOSS OF DATA, ARISING FROM ANY CAUSE OR THEORY. AUTHORIZED RESELLERS ARE NOT AUTHORIZED TO EXTEND ANY DIFFERENT WARRANTY ON TRANSITION NETWORKS' BEHALF.

Free Manuals Download Website

<http://myh66.com>

<http://usermanuals.us>

<http://www.somanuals.com>

<http://www.4manuals.cc>

<http://www.manual-lib.com>

<http://www.404manual.com>

<http://www.luxmanual.com>

<http://aubethermostatmanual.com>

Golf course search by state

<http://golfingnear.com>

Email search by domain

<http://emailbydomain.com>

Auto manuals search

<http://auto.somanuals.com>

TV manuals search

<http://tv.somanuals.com>