LANMASTER T8 8-PORT HUB SPECIFICATIONS

Standards

IEEE 802.3

Physical

Dimensions

137 mm x 137 mm x 25 mm

Power

Power Supply Adapter

AC Input (47-63 hertz):

| <u>PN</u> | <u>Requirement</u> | <u>Location</u> |
|-----------|----------------------------------|-------------------|
| 3532 | 120 volts, 60 hertz, 28 watts | USA/Canada/Mexico |
| 3535 | 230 volts, 50 hertz, 28 watts | Europe |
| 3534 | 100 volts, 50-60 hertz, 28 watts | Japan |
| 3533 | 240 volts, 50 hertz, 28 watts | United Kingdom |
| 3536 | 240 volts, 50 hertz, 28 watts | Australia |

33022.B

DC Output:

12 volts at 800 mA maximum.

Environment

| | |
|--------------|------------------------|
| Temperature: | 0-50°C (32° to 122° F) |
| Humidity | 10-90%, non condensing |
| Altitude | 0-10,000 feet |

Warranty

Lifetime

LANMaster™ T8 8-Port Ethernet™ Hub (E-TBT-HB-0804)

For assistance in installing, using, or maintaining the TRANSITION Networks LANMaster T8 8-Port Ethernet™ Repeater Hub, contact TRANSITION Networks Technical Support at:

(800) 260-1312

or contact your local distributor.

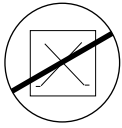

CAUTION: RJ connectors are NOT INTENDED FOR CONNECTION TO THE PUBLIC TELEPHONE NETWORK. Failure to observe this caution could result in damage to the public telephone network.

Der Anschluss dieses Gerätes an ein öffentliches Telekommunikationsnetz in den EG-Mitgliedstaaten verstösst gegen die jeweiligen einzelstaatlichen Gesetze zur Anwendung der Richtlinie 91/263/EWG zur Angleichung der Rechtsvorschriften der Mitgliedstaaten über Telekommunikationsendeinrichtungen einschliesslich der gegenseitigen Anerkennung ihrer Konformität.

Compliance Information

UL Listed

C-UL Listed (Canada)

CISPR/EN55022 Class A

FCC Regulations

This equipment has been tested and found to comply with the limits for a class A digital device, pursuant to part 15 of the FCC rules. These limits are designed to provide reasonable protection against harmful interference when the equipment is operated in a commercial environment. This equipment generates, uses, and can radiate radio frequency energy and, if not installed and used in accordance with the instruction manual, may cause harmful interference to radio communications. Operation of this equipment in a residential area is likely to cause harmful interference, in which case the user will be required to correct the interference at the user's own expense.

Canadian Regulations

This digital apparatus does not exceed the Class A limits for radio noise for digital apparatus set out on the radio interference regulations of the Canadian Department of Communications.

European Regulations

Warning

This is a Class A product. In a domestic environment this product may cause radio interference in which case the user may be required to take adequate measures.

Copyright Restrictions

© 1997 TRANSITION Networks.

All rights reserved. No part of this work may be reproduced or used in any form or by any means – graphic, electronic, or mechanical – without written permission from TRANSITION Networks.

Trademark Notice

All registered trademarks and trademarks are the property of their respective owners.

10BASE-2 Cable Specifications

The physical characteristics of the 10BASE-2 cable must meet or exceed IEEE 802.3 10BASE-2 specifications.

Cable Characteristics:

| | |
|--|---------------------------------|
| Cable type: | Stranded Coaxial RG58 (ThinNet) |
| Impedance: | 50 Ω @ 10 MHz |
| Mutual Capacitance: | 24 pF/ft \pm 20% @ 10 MHz |
| Maximum Cable Length: | 185 meters (610 feet) |
| Maximum number network connections: | 30 |
| Minimum distance between connections: | 0.5 meters (1.6 feet) |

Terminate 10BASE-2 cable at one end using a 50 ohm terminator and at the other end using a 50 ohm terminator grounded to earth ground.

10BASE-T Cable and Connector Specifications

The physical characteristics of the 10BASE-T cable must meet or exceed IEEE 802.3 10BASE-T specifications.

10BASE-T Cable Characteristics:

Category 3 wire or better is required; category 5 wire is recommended. Either shielded twisted pair (STP) or unshielded twisted pair (UTP) can be used. **DO NOT USE FLAT OR SILVER SATIN WIRE.**

Category 3:

| | |
|---------------------------------------|---------------------------------|
| Gauge | 24 to 22 AWG |
| Attenuation | 28 dB/1000' @ 10 MHz |
| Differential Characteristic Impedance | 100 Ω \pm 10% @ 10 MHz |

Category 5:

| | |
|---------------------------------------|---------------------------------|
| Gauge | 24 to 22 AWG |
| Attenuation | 20 dB/1000' @ 10 MHz |
| Differential Characteristic Impedance | 100 Ω \pm 10% @ 10 MHz |

Maximum Cable Length: 100 meters (330 feet)

10BASE-T Connector Characteristics:

The two active pairs in a 10BASE-T network are pins 1 & 2 and pins 3 & 6. Use only dedicated wire pairs (such as blue/white & white/blue, orange/white & white/orange) for the active pins. 10BASE-T cable for unlike devices (such as hub to terminal device) must be configured as straight through; 10BASE-T cable for like devices (such as hub to hub or terminal device to terminal device) must be configured as crossover.

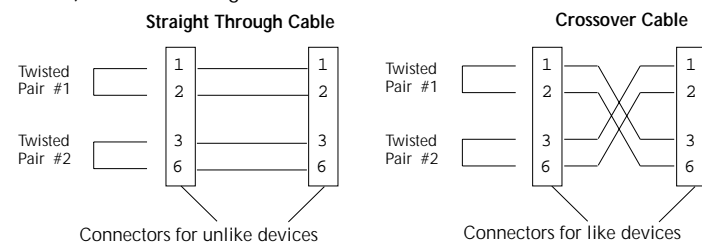

ETHERNET CABLE SPECIFICATIONS

Maximum number of terminal devices on Ethernet network: 1024

10BASE-5 Cable and Connector Specifications

The physical characteristics of the 10BASE-5 cable must meet or exceed IEEE 802.3 10BASE-5 specifications.

10BASE-5 Cable Characteristics:

| | |
|--|------------------------------|
| Cable type: | RG8 Solid Coaxial (ThickNet) |
| Impedance: | 50 Ω @ 10 MHz |
| Capacitance: | 26pF/ft |
| Maximum Cable Length: | 500 meters (1650 feet) |
| Maximum number network connections: | 100 |
| Minimum distance between connections: | 2.5 meters (8.2 feet) |

Terminate 10BASE-5 cable at one end using a 50 ohm terminator and at the other end using a 50 ohm terminator grounded to earth ground.

AUI Cable and Connector Specifications

The cable is a special 4-pair individually shielded with an overall braided shield.

Maximum AUI Cable Length: 50 meters (165 feet)

AUI Connector Characteristics:

| | | | |
|-------------------|--------------------------------|----------------|---------------|
| AUI Port: | Male DB-15 with locking posts. | | |
| AUI Connection: | Cable shell must be grounded. | | |
| Connector Legend: | 1 Logic Ref. | 6 Power Return | 11 Logic Ref |
| | 2 Collision+ | 7 N/C | 12 Receive |
| | 3 Transmit+ | 8 Logic Ref. | 13 Power |
| | 4 Logic Ref. | 9 Collision-- | 14 Logic Ref. |
| | 5 Receive+ | 10 Transmit- | 15 N/C |

10BaseFL Cable and Connector Specifications

The physical characteristics of the 10BaseFL cable must meet or exceed IEEE 802.3 10BaseFL specifications.

10BaseFL Cable Characteristics:

| | |
|-----------------------------------|---|
| Fiber Optic Cable Recommended: | 62.5/125 μ m multimode fiber |
| Optional: | 100/140 μ m multimode fiber 85/125 μ m multimode fiber 50/125 μ m multimode fiber |
| Fiber Optic Transmitter Power: | Average power: -15.0 dBm Peak power: -12.0 dBm \pm 1dBm |
| Fiber Optic Receiver Sensitivity: | Average sensitivity: -27.4 dBm Bit error rate: $\leq 10^{-10}$ |

Maximum Cable Length: 2000 meters (6500 feet)

10BaseFL Connector Characteristics:

ST type connectors (SMA type available upon request)

Table of Contents

| | |
|---|-----------|
| 1 INTRODUCTION | 1 |
| The LANMaster T8 | 1 |
| Networking the LANMaster T8 | 2 |
| Connectors, Switch, Indicators, | 3 |
| 2 SITE CONSIDERATIONS | 4 |
| 3 INSTALLATION | 5 |
| Unpacking the LANMaster T8 | 5 |
| Installing LANMaster T8 at Site | 6 |
| Installing Network Cable | 7 |
| 10BASE-T Requirements | 7 |
| 10BASE-2 Requirements | 8 |
| 10BASE-5 Requirements | 8 |
| 10-Mb/s Network Configuration Guidelines | 9 |
| Installing Twisted-Pair 10BASE-T Cable | 11 |
| Installing Thinnet 10BASE-2 Cable | 12 |
| Installing Thicknet 10BASE-5 Cable | 13 |
| Powering the LANMaster T8 | 14 |
| 4 OPERATION | 15 |
| Monitoring Power LED | 15 |
| Monitoring Status LEDs | 15 |
| 5 MAINTENANCE | 16 |
| Fault Isolation | 16 |
| Technical Support Contact | 16 |
| WARRANTY STATEMENT | 17 |
| ETHERNET CABLE SPECIFICATIONS | 19 |
| LANMASTER T8 8-PORT HUB SPECIFICATIONS | 21 |

1. INTRODUCTION

This guide is intended for the system or network administrator responsible for installing and monitoring a TRANSITION Networks LANMaster™ T8 8-Port Ethernet™ Repeater Hub. A working knowledge of local area network (LAN) operations, including familiarity with communications protocols used on interconnected LANs, is assumed.

The LANMaster T8

The TRANSITION Networks LANMaster T8 8-Port Ethernet Repeater Hub is a 10 Mb/s network device that connects 10BASE-T and 10BASE-2 OR 10BASE-5 Ethernet segments into a single Ethernet network.



LANMaster T8 Front



LANMaster T8 Back

Features:

- Eight fixed RJ-45 twisted-pair connectors at front provide terminal device connections
- Optional RJ-45 uplink port connector at front eliminates need for crossover cable between hubs
- BNC and AUI connectors at back provide optional connection to *EITHER* 10BASE-2 *OR* 10BASE-5
- LED indicators at front provide continuous LANMaster T8 network traffic data

The sole purpose of this remedy shall be provided the customer with the replacement or repair of non-conforming goods in the manner described in this Warranty statement. This exclusive remedy shall not be deemed to have failed of its essential purpose so long as TN is willing and able to repair or replace the defective item(s) or refund the purchase price.

TN reserves the right to inspect products claimed to be defective under warranty either at the customer's location or at TN's plant. TN assumes no liability for liability charges incidental to the adjustment, service, repairing, removal or replacement of the product, or other costs, or the expense of repairs made outside of its factory, except when made with TN's prior written consent. Additionally, Transition Networks reserves the right to charge for all testing and shipping incurred, if after testing, a return is classified as "No Problem Found".

TN's total liability in connection with the products and their installation to all persons and from all causes in the aggregate, whether in contract, tort, or strict liability, shall not exceed the amount paid to TN for the product directly related to the alleged damage. However, in no event shall TN have any liability to a customer or any third party for products manufactures according to the customer's specifications.

C. Return Procedure

The customer must follow this procedure for the return of defective items:

1. Locate the serial number(s) of the item(s) to be returned.
2. Determine the date the item(s) was received.
3. Contact Transition Networks Technical Support to determine if the problem can be corrected on site.

If not, and the product is covered by warranty, then:

- Call the distributor directly or contact TN.
- Request a Return Material Authorization (RMA).
- Ship the item, prepaid in original packaging to Transition Networks at the above address.
- Include the RMA number on the outside of the carton and/or on the Packing List.
- Include a copy of the RMA form.
- Include a copy of the original invoice or packing list (if possible) to expedite processing.
- The item(s) may be shipped by the customer or the distributor.
- Transition Networks will repair or replace the unit, at TN's discretion, and cover the cost of the return freight to the distributor or to the customer, whichever requested the RMA number.

If the item(s) was received **more than five years ago**, or if the item(s) is **no longer covered by warranty** for other reasons, then:

- Call the distributor or contact TN.
- Request a Material Repair Authorization number (MRA).
- Ship the item(s), prepaid, in the original packaging to Transition Networks at the above address.
- Include the MRA number on the outside of the carton add/or on the Packing List.
- Include a copy of the MRA form.
- Include a copy of the original invoice or packing list (if possible) to expedite processing.
- Only the customer (end-user) may send the items(s) to TN.
- TN will contact the customer after the item(s) have been received, inspected, and a cost estimate of the repair determined.
- The repair charges may be billed, with customer's approval, though the distributor, or on a prepaid or C.O.D. basis directly to the customer. The charges will include the cost of shipping.

The return authorization numbers are valid only for 90 days from the date issued.

Warranty Statement

A. Five Year Warranty

Transition Networks, Inc. (TN) warrants, for a period of five years, that TN products (with the exception of power supplies and fans that TN warrants for two years) will be free from defects in materials and workmanship, and will be in conformity with TN's specifications.

TN's warranty on products manufactured by or assembled for TN in accordance with a customer's specifications, is a five-year warranty that the goods conform to such specifications.

The warranty is invalidated if the goods have been subject to alterations, misuse, accident, Acts of God (e.g., damage by floods, lightning strikes, Etc.), tampering, improper maintenance, improper installation, or abuse. If the user is unsure about the proper means of installing or using the equipment, contact TN's free Technical Support or Network Design Services, which can be reached by:

Telephone 1.800.LAN.WANS or 612.941.7600
Fax 612.941.2322
E-mail techsupport@transition.com
Internet http://www.transition.com

THE ABOVE WARRANTY IS EXCLUSIVE AND EXTENDS ONLY TO PRODUCTS ASSEMBLED BY TRANSITION NETWORKS, INC. TO THE EXTENT PERMITTED BY LAW, TN DOES NOT MAKE AND DISCLAIMS ALL OTHER WARRANTIES, EXCEPT TITLE, EXPRESSED OR IMPLIED, INCLUDING, BUT NOT LIMITED TO, ANY WARRANTY OF DESCRIPTION, MERCHANTABILITY, FITNESS FOR A PARTICULAR PURPOSE OR NON-INFRINGEMENT, AND ANY WARRANTY BASED UPON PRIOR WRITTEN OR ORAL REPRESENTATIONS REGARDING SUCH PRODUCTS MADE BY TN, ITS EMPLOYEES, AGENTS, OR REPRESENTATIVES.

B. Limitations and Exclusions

If the customer believes any goods sold by TN are defective and within the warranty period, the following general procedure will be followed:

1. Locate the serial number and delivery date of the item(s).
2. Notify TN within the warranty period.
3. TN will promptly issue a return authorization form for the goods.
4. Upon receiving the form, the customer will promptly return the item(s) at customers own expense, shipped prepaid, to the distributor from which it was purchased, or directly to TN.

TN will only accept goods for return if the following conditions have been met:

1. A return form is obtained from TN.
2. The freight charges have been prepaid by the customer.
3. Goods are re-packed in their original packaging.

If under warranty TN shall, at its option, (1) repair the goods free of charge (2) replace the goods free of charge, or (3) accept the return of the item(s) and credit the current price to the reseller (within 90 days of purchase), or (4) if the goods are not under warranty, will repair the item(s) at a minimum charge of USD \$200 (two hundred U.S. dollars) per item.

THIS IS THE EXCLUSIVE REMEDY FOR ANY BREACH OF WARRANTY. IN NO EVENT SHALL TRANSITION NETWORKS BE LIABLE FOR SPECIAL, INDIRECT, INCIDENTAL OR CONSEQUENTIAL DAMAGES OF ANY KIND, WHETHER FOR BREACH OF ANY CONDITION OF SALE, FOR NEGLIGENCE, ON THE BASIS OF STRICT LIABILITY, CONTRACT, OR OTHERWISE AND IRRESPECTIVE OF WHETHER TN IS INFORMED BY CUSTOMER OF THE POSSIBILITY OF SUCH DAMAGES IN ADVANCE OF THIS SALE.

Networking the LANMaster T8

The LANMaster T8 Repeater Hub can be installed in an Ethernet network by connecting 10BASE-T cable between RJ-45 connectors at the front of the LANMaster T8 and various network terminal devices.

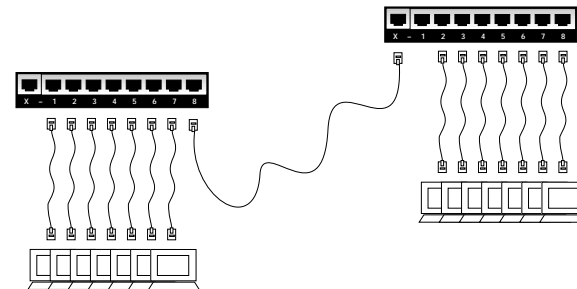
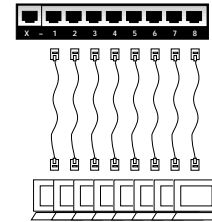

Additionally, LANMaster T8 hubs can be cascaded using twisted-pair 10BASE-T cable and the X (crossover) uplink RJ-45 connector.

And, the BNC connector on the LANMaster T8 back can be connected to 10BASE-2 or the AUI connector on the LANMaster T8 back can be connected to 10BASE-5 (or, through a media converter installed on the AUI connector, to 10BASE-T, 10BASE-5, or 10BASE-FL).

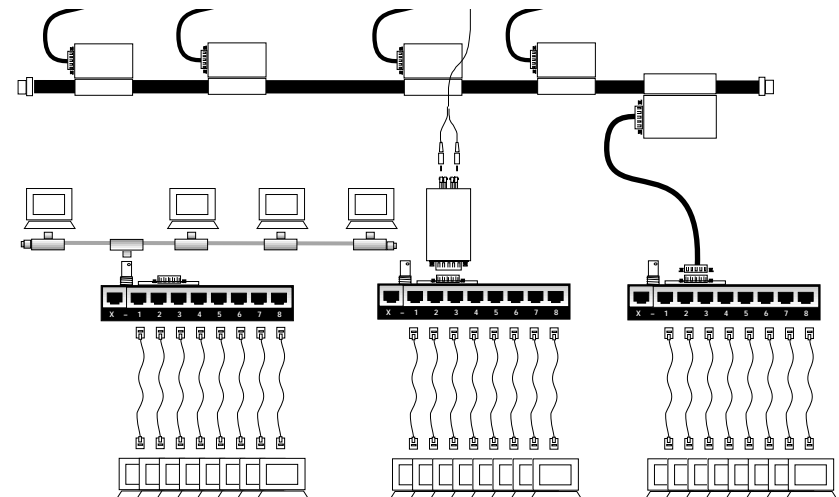

Connectors and Indicators

CONNECTORS

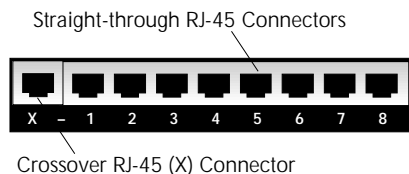

Eight (8) straight-through **RJ-45 connectors**, labeled 1-8, and one (1) crossover **RJ-45 connector**, labeled X, are located on the front of the LANMaster T8.

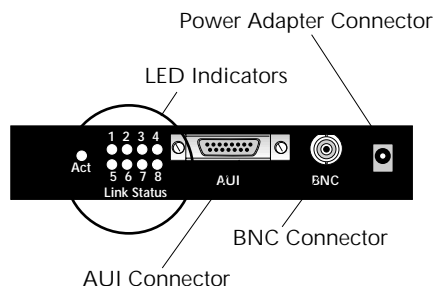

One (1) **AUI connector**, one (1) **BNC connector**, and one (1) **AC power supply adapter connector** are located on the back of the LANMaster T8.

LED INDICATORS

Steady green **Act(ivity)** LED indicates connection of the LANMaster T8 to external AC power. *Blinking green* **Act(ivity)** LED indicate network traffic.

Steady green **Link Status** LEDs indicate (for each port) the integrity of the network link at the RJ-45 connector. *Blinking green* **Link/Receive** LEDs indicate (for each port) reception of valid data.

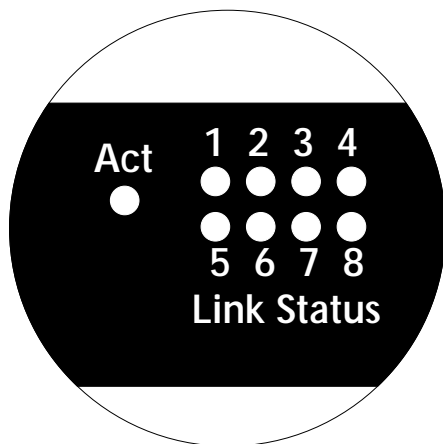

5. MAINTENANCE

WARNING: DO NOT, UNDER ANY CIRCUMSTANCES, open and attempt to repair the LANMaster T8. Failure to observe this warning could result in personal injury or death from electrical shock.

NOTE: Failure to observe the above warning will immediately void the warranty.

Fault Isolation

If two network devices fail to communicate through the LANMaster T8, consider the following:

- Are the LEDs described in the previous section functioning properly?
- Do network devices have Link Integrity enabled?
- Do network devices communicate when the LANMaster T8 is not installed between them?
- Is flat or "silver satin" wire used in site internal wiring?
- Are internal wiring patch cords, punch down blocks, and wall jacks properly pinned or configured?
- Is the thinnet cable unbroken and properly connected?
- Are network interface cards properly configured?

Technical Support Contact

For assistance in fault isolation and in maintaining the LANMaster T8, contact:

Technical Support

(800) 260-1312

or your local distributor.

4. OPERATION

The LANMaster T8 requires no intervention beyond occasionally monitoring the Power and Status LEDs.

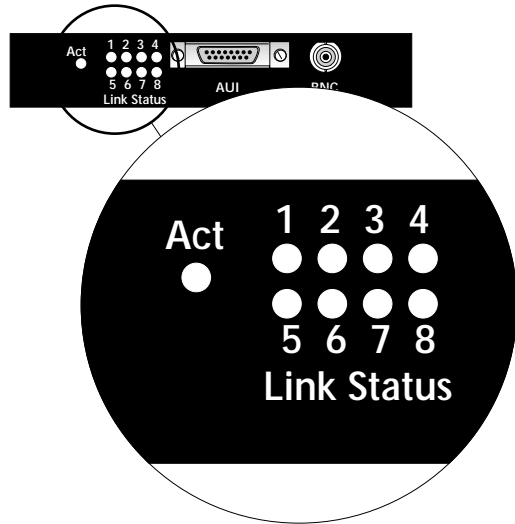

Monitoring Status LEDs

Steady green **Act(ivity)** LED indicates connection of the LANMaster T8 to external AC power. *Blinking green* **Act(ivity)** LED indicate network traffic.

Steady green **Link Status** LEDs indicate (for each port) the integrity of the network link at the RJ-45 connector. *Blinking green* **Link/Receive** LEDs indicate (for each port) reception of valid data.

2. SITE CONSIDERATIONS

The site for the LANMaster T8 must provide:

- AC power outlet for each LANMaster T8
- Adequate ventilation
- Standard environmental conditions
- Isolation from electrical noise, including radio transmitters and broadband amplifiers, motors, high power electrical lines, or fluorescent light fixtures.

Additionally:

- The twisted pair cables should not run in the same conduit with power line cables.
- Phone lines should be separated from data cables.
- Flat or "silver satin" cables should not be used.
- RJ-45 connected cables should be configured as crossover or straight through according to installation requirements.

And:

- Since the LANMaster T8 is an Ethernet repeater, the entire installation should comply with the IEEE Ethernet 802.3 specification

3. INSTALLATION

To install the LANMaster T8:

- Unpack the LANMaster T8
- Install LANMaster T8 at site
- Install Network Cable
- Power the LANMaster T8.

Direction is provided in the pages that follow.

Unpacking the LANMaster T8

The LANMaster T8 packing contents should include the following:

| Item | Part Number |
|----------------------|---|
| LANMaster T8 Hub | E-TBT-HB-0804 (includes mounting brackets and screws, BNC T-connector and terminator, and adhesive-backed rubber feet) |
| Power Supply Adapter | 3532, 3533, 3534, 3535, or 3536 (depending upon power configuration in country where installed) |
| User's Guide | 33022 |

Powering the LANMaster T8

To power ON the LANMaster T8:

1. Verify that the LANMaster T8 power supply adapter is the correct one for the site installation.
2. At LANMaster T8 back, locate the power receptacle.
3. Connect the LANMaster T8 power connector end of the power supply adapter to LANMaster T8 power receptacle.
4. Plug external power connector end (male) of the power supply adapter into correct voltage AC wall socket.
5. At LANMaster T8 front, verify that **Act(ivity)** LED is illuminated.

Installing Thicknet 10BASE-5 Cable

The LANMaster T8 provides a female AUI connector at the back for network connection to 10BASE-5 through an AUI drop cable or to 10BASE-2, 10BASE-T, or 10BASE-FL through a transceiver.

CONNECTING TO 10BASE-5 USING AUI DROP CABLE

To connect to 10BASE-5 cable using AUI drop cable:

1. Locate or build IEEE 802.3 compliant AUI drop cable.
2. Connect AUI drop cable male connector to female AUI (DTE) connector on LANMaster T8.
3. Connect AUI drop cable female connector to the AUI port on a 10BASE-5 cable transceiver or media attachment unit (MAU).
4. Verify that 10BASE-5 segment is terminated at both ends using 50-ohm terminators.

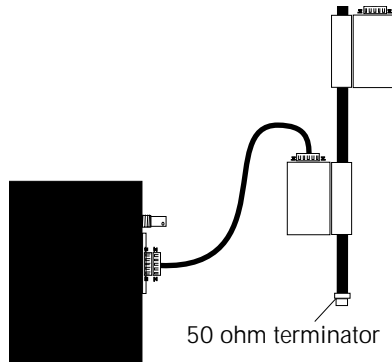

CONNECTING TO NETWORK USING TRANSCEIVER

NOTE: Refer to transceiver documentation for detailed specifications.

To connect to network using transceiver:

1. Locate IEEE 802.3 compliant transceiver with male AUI connector and with required network media connector.
2. Connect transceiver male AUI connector to the female AUI connector on LANMaster T8.
3. Referring to transceiver documentation, connect transceiver network media connector to the network media.

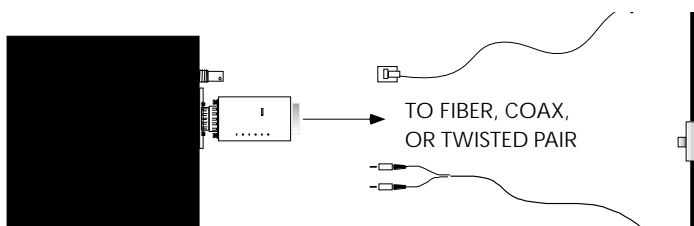

Installing LANMaster T8 at Site

NOTE: Mounting brackets, screws, and rubber feet are provided.

To install the LANMaster T8 **on table or other flat surface**:

1. Carefully turn LANMaster T8 to side.
2. Install four (4) rubber feet (included with packing material):

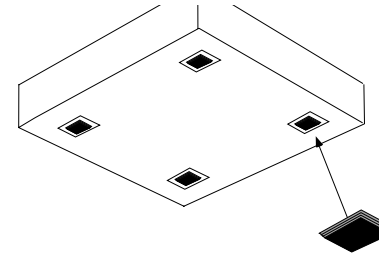

- Separate rubber feet.
 - Remove protective paper from adhesive surface of rubber foot.
 - Position and secure each rubber foot as shown.
3. Return LANMaster T8 to upright position.

To install the LANMaster T8 mounting bracket **under shelf or on wall**:

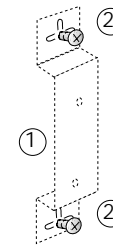

1. Using mounting bracket as a guide, with pencil or other marking device, mark screw installation locations on wall or under shelf.

2. Using Phillips screwdriver, install two (2) screws (included with packing material) at installation locations marked on wall or under shelf.

3. Using Phillips screwdriver, install two (2) screws (included with packing material) through mounting bracket securely into LANMaster T8 chassis.

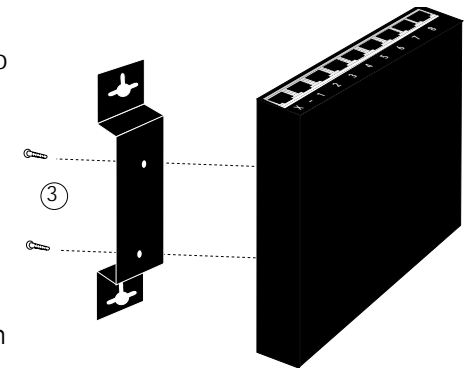

4. Carefully install mounting bracket, with attached LANMaster T8 chassis, to installed mounting screws, aligning mounting bracket so that mounting screws are secured at narrow end of bracket mounting

Installing Network Cable

10BASE-T Requirements

STRAIGHT-THROUGH/CROSSOVER CABLE/CONNECTOR

NOTE: The 10BASE-T cable and RJ-45 jacks for **hub to terminal device** connections must be configured as **straight through**. The 10BASE-T cable and RJ-45 jacks for **hub to hub** connections must be configured as **crossover**.

The "X" port provided on the LANMaster T8 changes a physical straight through cable configuration to a logical crossover cable configuration for hub to hub connections.

Therefore, ensure that all 10BASE-T cable to be installed is straight-through:

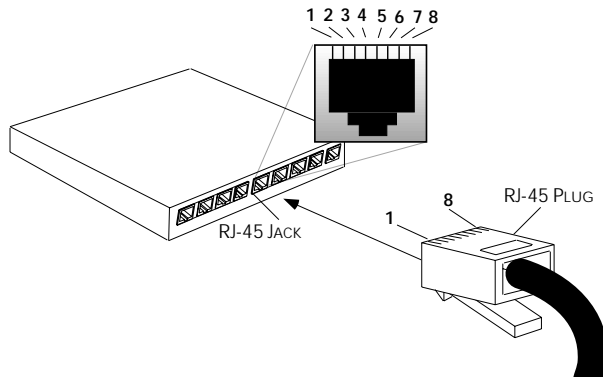

Straight Through Cable at RJ-45 Plug

HubPC, transceiver, NIC, printer

RJ-45 MaleRJ-45 Male

| | | |
|---|-------|---|
| 1 | | 1 |
| 2 | | 2 |
| 3 | | 3 |
| 6 | | 6 |

The two active pairs in a 10BASE-T network are pins 1 & 2 and pins 3 & 6. Use only dedicated wire pairs (such as blue/white & white/blue, orange/white & white/orange) for the active pins.

Installing Thinnet 10BASE-2 Cable

The LANMaster T8 has a female BNC MDI connector installed at the back for connection to 10BASE-2 cable and comes with a mating T-connector and a 50-ohm segment terminator for making the cable connection.

To connect to 10BASE-2 network cable:

1. Locate or build IEEE 802.3 compliant 10BASE-2 cable with male BNC connectors installed at both ends.
2. Install the mating T-connector to the female BNC connector on the LANMaster T8.
3. Install 10BASE-2 cable to one side of the T-connector.
4. Install 10BASE-2 cable to other side of the T-connector OR, if the LANMaster T8 is the last network device in the daisy chain, install a 50-ohm terminator.
5. Verify that the 10BASE-2 segment coax cable segment is terminated properly at both ends.

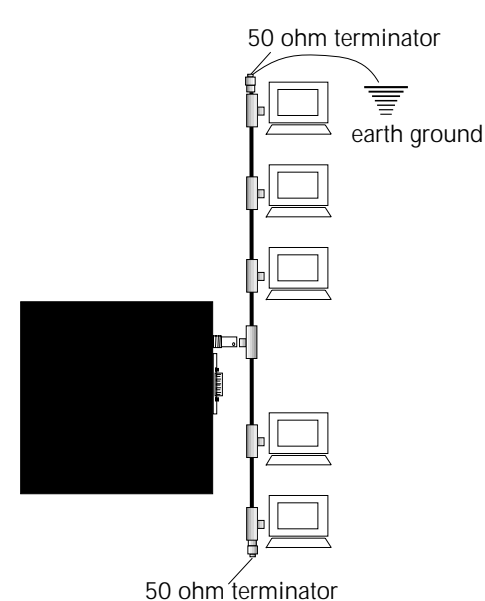

In a coax thinnet installation, the first and last device in the daisy-chain must be terminated with a 50 ohm terminator. Additionally, the 10BASE-2 segment must be grounded to "earth ground" at one end.

Installing Twisted-Pair 10BASE-T Cable

To connect 10BASE-T Cable to LANMaster T8 RJ-45 connectors:

1. Locate or build 10BASE-T cables that are:
 - 802.3 compliant (See page 20.)
 - with *straight through* connector/cable configuration (See page 7.)
 - with male RJ-45 plug connectors at both ends.
2. Connect male RJ-45 plug connector at one end of 10BASE-T cable to LANMaster T8 RJ-45 jack connector.
3. Connect male RJ-45 plug connector at other end of 10BASE-T cable to DTE terminal RJ-45 jack connector or to RJ-45 jack connector on other hub.

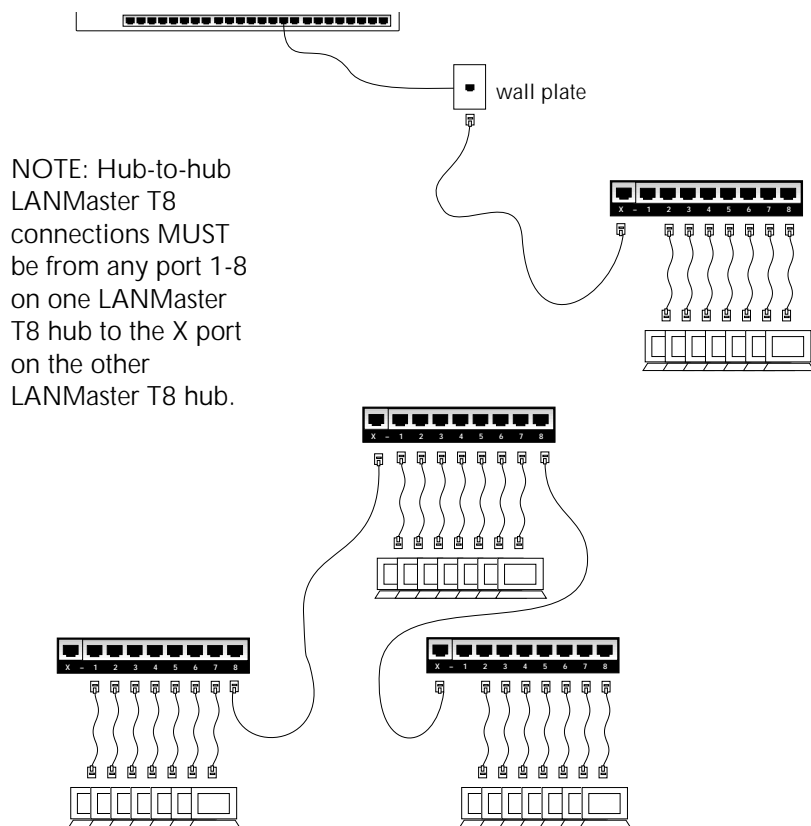

NOTE: The IEEE 802.3 standard states that the shield of a coax trunk cable shall make electrical contact with an earth reference once and only once per segment. Failure to provide an earth ground to a 10BASE-2 or 10BASE-5 segment may allow ambient RF energy to couple onto the cable shield, resulting in intermittent network failure. More than one ground per segment may allow a potential difference between the two grounds to cause current to flow, damaging components. And, since Ethernet senses collisions on 10BASE-2 and 10BASE-5 cable by monitoring the shield voltage level, more than one ground could cause false collisions that result in repeater ports partitioning and network traffic beyond the partition ceasing.

10BASE-2 Requirements

Thinnet 10BASE-2 cable "daisy-chains" network devices.

With a maximum segment length of 185 meters and a minimum segment length of 0.5 meters, the coaxial cable must have a 50 ohm characteristic impedance. Standard BNC connectors and "T's" provide access to the media, typically connected directly to the back of network interface cards, eliminating the need for an external transceiver.

Only 30 transceivers can be installed onto a 10BASE-2 Ethernet segment, spaced at least 0.5 meters apart. The first and last device in the daisy-chain must be terminated with a 50 ohm terminator, grounded to "earth ground" at one end.

10BASE-5 Requirements

Thicknet 10BASE-5 cable is the original Ethernet.

With a maximum segment length of 500 meters and a minimum segment length of 1.5 meters, the coaxial cable must have a 50 ohm characteristic impedance.

As many as 100 transceiver can be installed onto a 10BASE-5 Ethernet segment, spaced at least 2.5 meters apart. There must be a type N 50 ohm terminator installed at each end of a thick coaxial cable segment.

10-Mb/s Baseband Network Configuration Guidelines

Ethernet 802.3 specifications define network configuration guidelines for the 10-Mb/s baseband network:

10BASE-T, 10BASE-2, and 10BASE-5 cable segments can be installed as a single Ethernet collision domain if the cable segments are connected using repeaters.

When connecting LANMaster T8 repeater hubs, the transmission path between any two Data Terminating Equipment (DTE) network devices can consist of no more than five segments. (A segment is the independent network cable connection between repeaters or between repeaters and network devices.)

To verify the network configuration by assigning segment numbers to cable connections:

1. Determine the two terminals in the network which are separated by the greatest number of segments.
2. Assign a segment path between the terminals by labeling the cable connected to one of the terminals "segment 1" and the segment connected to the other terminal "segment n" ($n = \text{total number of segments} \leq 5$).
3. To verify that no segment paths contain more than n segments, assign segment paths and numbers to all other terminals.
4. Verify that no more than three of the segments are 10BASE-2 or 10BASE-5 with multiple stations attached.

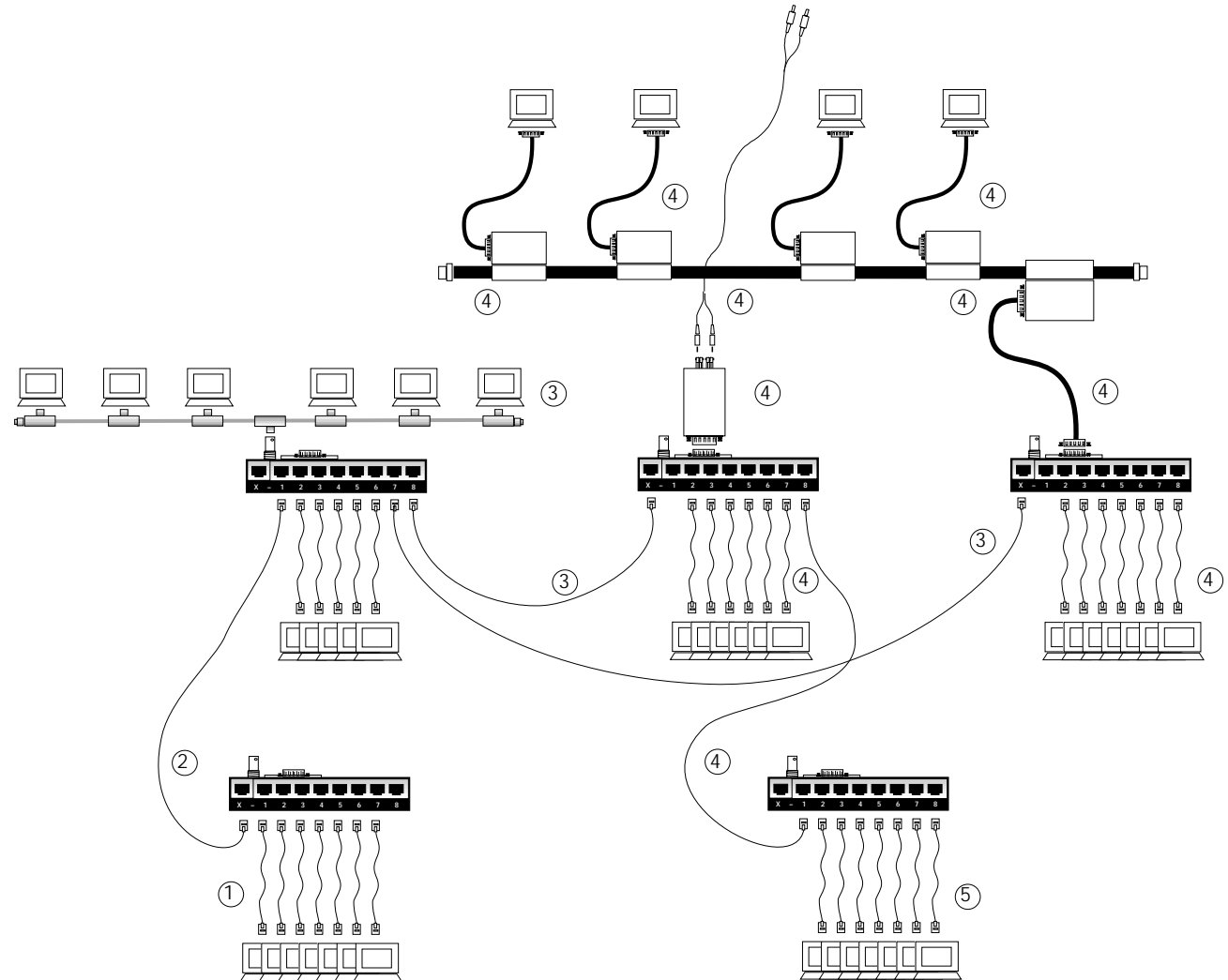

Free Manuals Download Website

<http://myh66.com>

<http://usermanuals.us>

<http://www.somanuals.com>

<http://www.4manuals.cc>

<http://www.manual-lib.com>

<http://www.404manual.com>

<http://www.luxmanual.com>

<http://aubethermostatmanual.com>

Golf course search by state

<http://golfingnear.com>

Email search by domain

<http://emailbydomain.com>

Auto manuals search

<http://auto.somanuals.com>

TV manuals search

<http://tv.somanuals.com>