

# TRICITY BENDIX

we'll do the homework

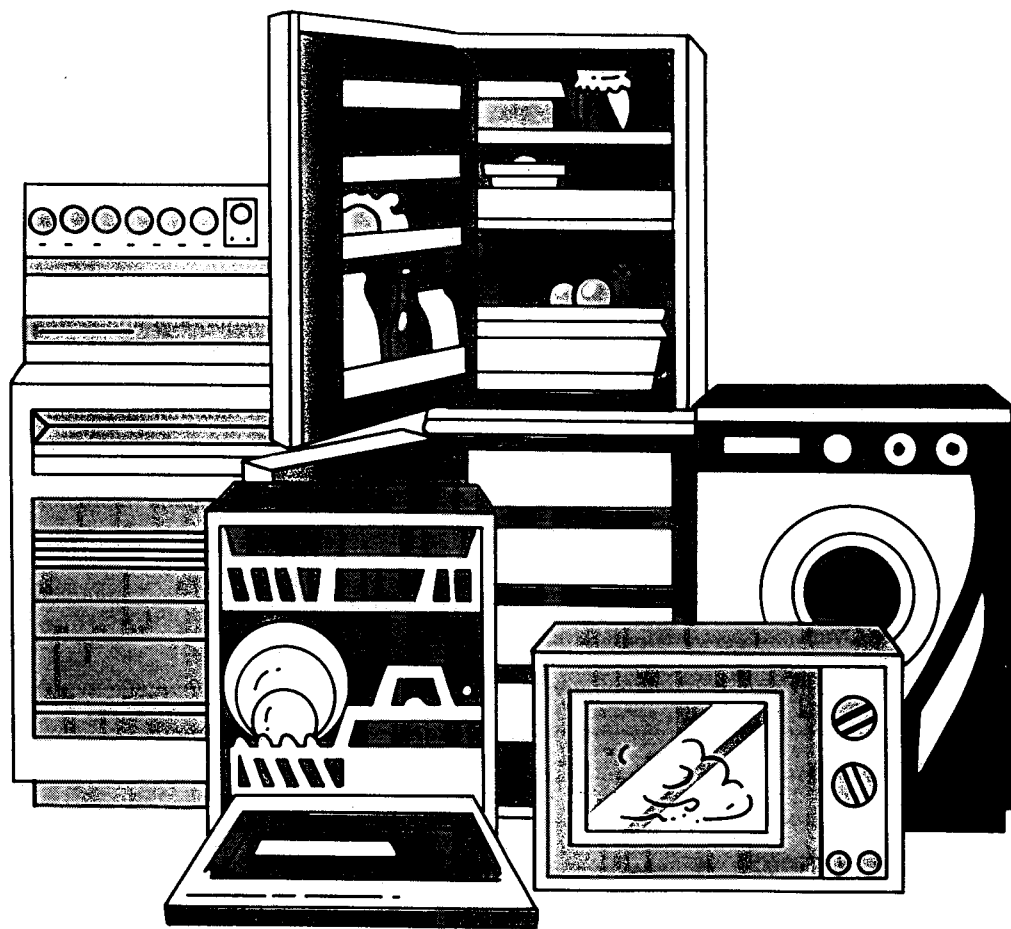

## Operating and Installation Instructions

Model No.

**IM 900**

# Table of Contents

## General Instructions

● WARNING—This appliance must be earthed.....	3
● How a Microwave Oven Makes Cooking Faster, Easier and Much More Enjoyable.....	3
● The Extra Features of Your Microwave Oven.....	4
● Function of "Boomerang Turntable" .....	4
● Installation and setting the time of day .....	5
● Names of Oven Parts .....	5
● Oven Control Panel .....	6

## User Instructions

● User Instructions—Cooking Guide .....	7
● Easy Use Chart .....	7

## Detailed Directions

● "High Power" and "Variable Power" cooking.....	8
● "Variable Power" Setting Guide.....	9
● Re-heating cook-chilled foods .....	9
● "Two Stage" Cooking.....	10
● "Rapid Reheat" Cooking.....	11
● "Delay Start" Cooking.....	12
● "Programmed Defrost".....	13
● "Programmed Defrost" Chart.....	14-16

<b>How to Use Your Microwave Oven Safely (Important).....</b>	<b>17</b>
Taking Care of Your Microwave Oven.....	17
Usable Cooking Utensils and Materials .....	18
Utensils and Material to Avoid.....	18
A Few Other Precautions (Important) .....	19
What to Do if Repairs Are Needed.....	19
Electrical Appliance Guarantee (Warranty) .....	19
Tricity Bendix Service Centres .....	20

# Connecting to the mains

Before you use your oven, check that the voltage shown on the data label located on the face of the oven conforms with your mains supply.

The mains lead is fitted with a non-rewireable moulded-on 13 amp plug containing a 13 amp fuse. If the fuse requires replacing at any time, the fuse cover/carrier should be removed using a small screwdriver to lever it out. The old fuse should be replaced by a 13 amp ASTA approved BS1362 fuse and the fuse cover/carrier must be refitted before the plug is used again.

If the plug supplied on the mains lead is not suitable for the socket in your home, it should be cut off and disposed of safely, or destroyed, to avoid any possible shock hazard resulting from the plug being inserted into a 13 amp socket elsewhere in the house. A suitable replacement plug should then be fitted as given below. (If a 13 amp plug and socket are not used, the circuit supplying the oven should contain a 13 amp fuse).

## WARNING – This appliance must be earthed

### IMPORTANT

The wires in this mains lead are coloured in accordance with the following code:

Green-and-yellow: Earth.  
Blue: Neutral.  
Brown: Live.

As the colours of the wires, in the mains lead of this appliance may not correspond with the coloured markings identifying the terminals in your plug, proceed as follows:

The wire which is coloured green-and-yellow must be connected to the terminal in the plug which is marked with

the letter E or by the earth symbol  $\equiv$  or coloured green or green-and-yellow.

The wire which is coloured blue must be connected to the terminal which is marked with the letter N or coloured black.

The wire which is coloured brown must be connected to the terminal which is marked with the letter L or coloured red.

### FUSE

The appliance must be protected by a 13-amp fuse, fitted to the 13-amp mains plug (BS1363).

## How a Microwave Oven Makes Cooking Faster, Easier and Much More Enjoyable

- 1. A feast in minutes.**  
High energy microwaves penetrate the food and cook it quickly, evenly and efficiently.
- 2. Natural flavour.**  
Microwave cooking preserves the natural taste and nutritive value of the food to a much higher degree than conventional cooking methods.
- 2. Utensils.**  
Glassware, earthenware, ceramic, practically all utensils EXCEPT METAL ONES are perfectly suitable for microwave cooking (for further information see p. 18).
- 4. Simplified operation.**  
You are cooking by time, and not by heat. Just key in the power level and cooking time, and press "START".
- 5. Clean, cool operation.**  
No smoke, no grease, no heat. Your kitchen stays cool and clean at all times.
- 6. Perfect for defrosting and re-heating.**  
When there is no time for natural thawing of frozen foods, your microwave oven can reduce the process to a matter of minutes. It defrosts all kinds of frozen foods and it re-heats fast.
- 7. Economical.**  
Since the required cooking time is extremely short, microwave cooking is more economical than conventional ovens. No pre-heating is required.
- 8. Always undercook.**  
Cooking times may vary according to the temperature of the food, the density of the food, and the ingredients of the food. So always under-cook in the first instance—you can always pop the food back for a few seconds if it is not quite done.

# The Extra Features of your Microwave Oven

1. **Programmed Defrost for gentle and efficient defrosting.**
2. **Variable power control.**  
A choice of 6 power levels including defrost.
3. **See-through window.**  
The progress of cooking can be observed while the oven is operating.
4. **Stainless steel interior - for easy cleaning.**
5. **Five separate safety features.**
  - a) **Latch system:** When the door release button is pushed, a built-in switch turns off the oven before the door is opened.
  - b) **Door switch:** When the door is opened this switch automatically turns off the oven.
  - c) **Choke seal:** a special seal around the door prevents all electro-magnetic radiation leakage from the oven.
  - d) **Thermal limiter:** should the temperature of the magnetron rise above the limit, the oven is automatically switched off.
  - e) **Monitor switch:** should the latch switch fail to function properly, this switch is activated to prevent the oven from operating.
6. **Compact, lightweight, easy to move.**  
Fits easy on a kitchen work surface. See installtion on page 5. Light enough to be moved to a summer house or seaside home.
7. **Practical dimensions.**
  - a) Overall: 55.0(W) 37.9(D) 35.0(H) cm
  - b) Oven: 34.8(W) 35.9(D) 24.1(H) cm
8. This appliance conforms to the requirements of EEC Radio Interference Directive 87/308/EEC.

## Function of "Boomerang Turntable"

This turntable is specially designed to return to its original starting position when cooking is finished. If however you open the door during cooking it will stop immediately, even if it has not reached the correct position. When the oven is stopped before the programmed cooking time is finished, for example, by opening the door, the food should be placed in its original position. Otherwise the food will not reach its original position when the cooking cycle is complete.

### IMPORTANT

When the 15 or 30 second setting is used for setting cooking times the oven light, fan motor and turntable motor will operate for a few seconds after the timer has reached zero to enable the turntable to return to its original position. The magnetron, providing heating power switches off when the timer reaches zero.

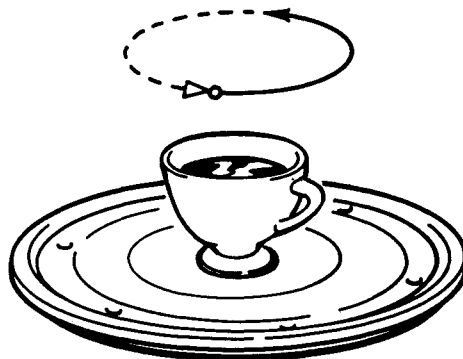

# Installation

1. **Remove any stickers and protective sheets from the door, operating panel.**
2. **Install the oven on a flat, level surface.**
  - Surface must be strong enough to safely bear the weight of the oven, 22kg and the contents. To avoid the possibility of causing vibration or noise the oven must be in a stable position.
  - When oven is first plugged into power outlet, "0:00" will flash in the display window, if not, switch off at power outlet, unplug the unit and reinsert the plug into the wall outlet.
  - To set time of day, touch "CLEAR/ STOP"; then touch "CLOCK SET". Touch "HOUR"; keep on touching for correct hours, and touch "MINUTE"; keep on touching for correct minutes; then touch "CLOCK SET". (This is also explained in "Easy Use Chart" Clock Section on Page 7).
3. **Keep the oven away from heat and water.**  
Exposure to heat and water can lower oven efficiency and lead to malfunctioning, so be sure to install the oven away from heat and water sources.
4. **Do not block air vents on the cabinet and also do not place any articles on the top of the oven.**  
If air vents are blocked during operation, the oven may over heat, and this may lead to malfunctioning. Hot air escapes from this vent, so be sure not to obstruct it or let curtains come between the oven and the rear wall.

5. **Place the oven as far away from radios and T.V.'s as possible.**  
This oven does conform to EEC requirements of radio interference suppression, but some interference may occur if it is placed too close to a radio or TV, so keep them as far apart as possible.
6. **If positioned in a corner, leave a gap of at least 2.0cm from the right side wall.**

## NOTE

It is quite normal for steam to be emitted around the door, or for misting to occur on the door, or even for water droplets to appear below the door during the cooking cycle. This is merely condensation from the heat of the food and does not affect the safety of your oven. The door is not intended to seal the oven cavity completely but its special design contributes to the complete safety of the appliance.

# Names of Oven Parts

Oven Cavity  
Sealing Surfaces  
See Through Door  
Latch Hook

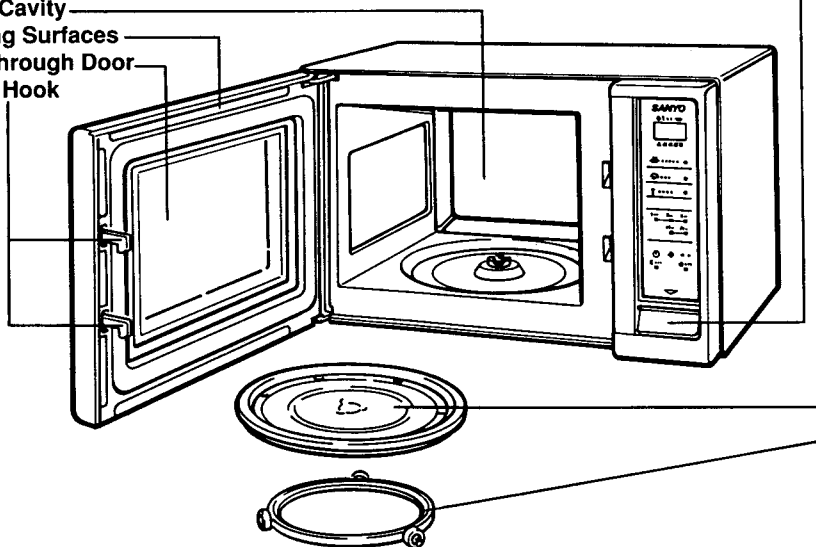

## Door Release Button

By pushing this button the latch system cuts off all circuits and stops the oven before the door can be opened.

## Glass Turntable

Made of special heat-resistant glass. Food in a microwaveproof receptacle is placed on this for cooking. Put the turntable on the base of the cavity on top of the roller rest.

## Roller Rest

Place the rest on the cavity base to support the glass turntable before placing the turntable on top.

Remove your Oven and all material from the shipping carton. Your oven comes with the following accessories.

Glass Turntable .....	1	Operating Instructions .....	1
Roller Rest .....	1	Cook Book .....	1

Do not use this Microwave Oven for commercial purposes. This Microwave Oven is made for domestic use only. If used in a non-domestic situation, the guarantee will be invalidated.

# Oven Control Panel

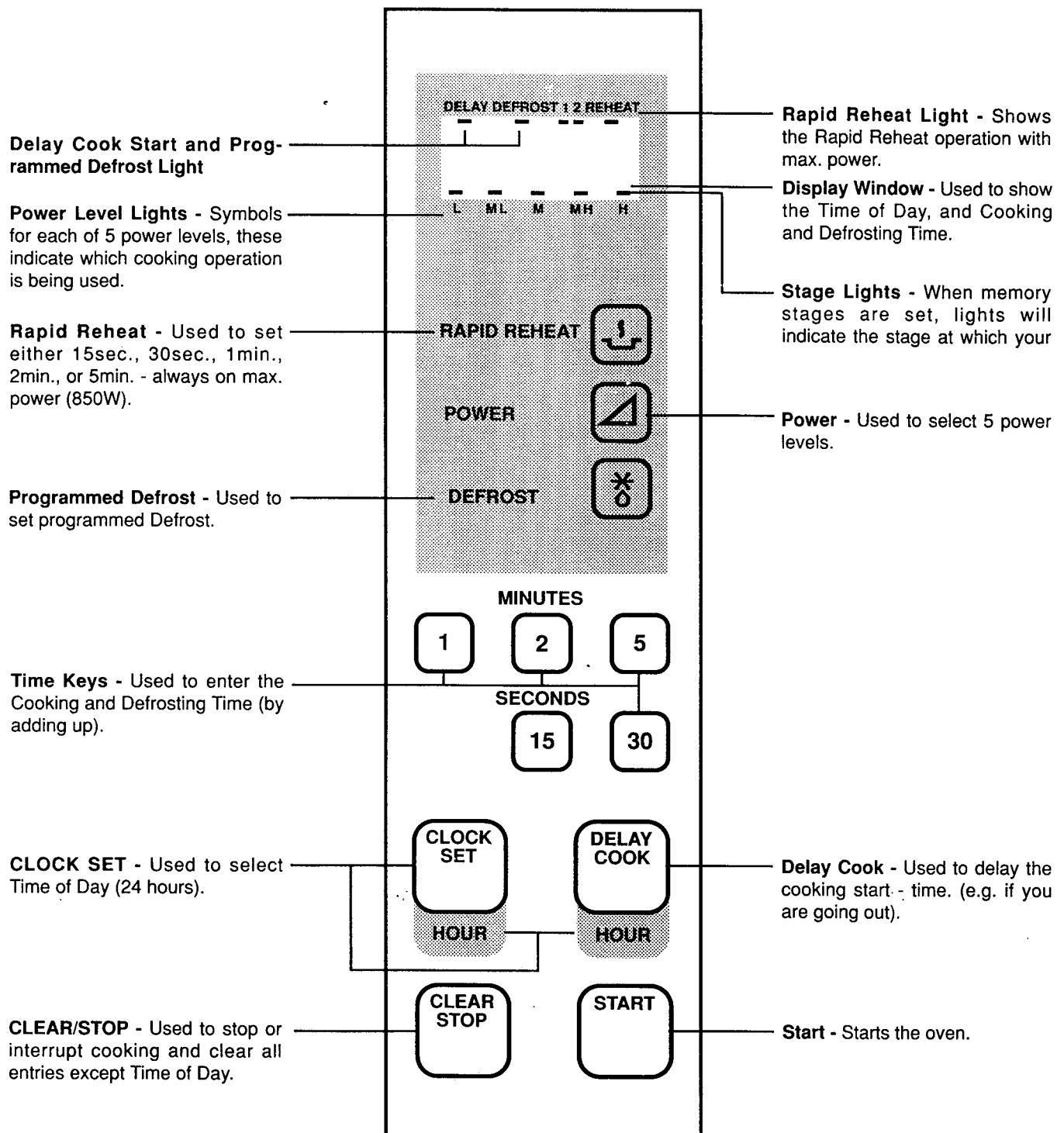

## NOTE: Setting the Cooking Time (Time Keys).

The Time Settings are made by the add-up method e.g. for 4 minutes press two minutes twice.

Always check that you have entered the correct cooking time.

Each "beep" means an entry and as your digitouch panel is sensitive you may inadvertently enter too many digits, e.g. 2min... 1min... = 3 minutes, 5min... 5min... = 10 minutes.

A "beep tone" sounds when a "pad" on the control panel is touched, to indicate a setting has been entered.

# User Instructions — Cooking Guide

## "High Power" Cooking

High is 650W. This is ideal for prime cooking of most foods. The enclosed cook book will give further instruction.

## "Variable Power" Cooking

Many foods require slower cooking to give the best results. In addition to "H" there are 4 other power levels. Further information on how these power levels can be used can be found on page 9.

### To Set Power Level:

Power bar indicator in the Display Window will shift from High to the lower power by holding your finger on the " [ ] power" pad.

After reaching the Lower Power "L", power display will return to "H" and continue to shift.

To stop your desired power level simply remove your finger from the " [ ] power" pad.

## "Programmed Defrost"

This special setting has been designed to cut down defrosting times. It does this by initially defrosting on high "H" and then automatically switching down to medium low "ML". See page 13 for detailed directions.

## "Delay Start" Cooking

This oven can be programmed to begin cooking automatically at a pre-set Time of Day. See page 12. for detailed instructions.

## "Two Stage" Cooking

Some recipes need more than one cooking stage. Many foods will cook better when cooked for a period of time at one power setting and then cooked for another period of time at a different power setting.

With a cake, for example, the cookbook may recommend cooking at the "MH" setting, followed by a period of cooking time at the "H" High Setting. "MH" medium high allows the cake to rise gently and then "H" High finishes the cooking cycle. You can preset both stages at the beginning, start the oven, and then the oven will change automatically into the second stage at the preset time. For detailed directions on "Two Stage" cooking refer to Page 10.

## "Rapid Reheat" Cooking

This special feature cuts down even further the number of controls you have to touch. For the ultimate in the convenience cooking any one of the time keys turn into "instant start pads" once "Rapid Reheat" has been touched, (no need to even press START). Rapid Reheat set is automatically preset on 850W.

For instance: touch "Rapid Reheat", 1min: oven automatically starts cooking for 1 minute.  
touch "Rapid Reheat", 5min: oven automatically starts cooking for 5 minutes.

See page 11 for detailed directions.

# Easy Use Chart

Your new DIGITOUCH control panel allows you to use your microwave oven in many ways.

CLOCK	"HIGH POWER" and "VARIABLE POWER" Cooking	"TWO STAGE" COOKING
<p>To set:</p> <ol style="list-style-type: none"> <li>1. Touch "CLEAR/STOP".</li> <li>2. Touch "CLOCK SET".</li> <li>3. Touch "HOUR": Keep on touching for correct hours, and touch "MINUTE" keep on touching for correct minutes.</li> <li>4. Touch "CLOCK SET".</li> </ol> <p>This "locks" in the time and starts the clock running.</p>	<p>To set:</p> <ol style="list-style-type: none"> <li>1. Touch "CLEAR/STOP".</li> <li>2. Touch "POWER" and select desired power level.</li> <li>3. Touch time key(s) for desired cooking time.</li> <li>4. Touch "START".</li> </ol> <p>(See page 8 for more detailed instructions).</p>	<p>To set:</p> <ol style="list-style-type: none"> <li>1. Touch "CLEAR/STOP".</li> <li>2. Touch "POWER" and select desired power level for first cooking stage.</li> <li>3. Touch time key(s) for desired cooking time.</li> <li>4. Touch "POWER": and select desired power level for second cooking stage.</li> <li>5. Touch time key(s) for desired cooking time.</li> <li>6. Touch "START".</li> </ol> <p>(See page 10 for more detailed instructions).</p>
"RAPID REHEAT" COOKING	"PROGRAMMED DEFROST"	"DELAY START" COOKING
<p>To set:</p> <ol style="list-style-type: none"> <li>1. Touch "CLEAR/STOP".</li> <li>2. Touch "RAPID REHEAT".</li> <li>3. Touch one time key only for desired cooking time on max. power.</li> </ol> <p>(See page 11 for more detailed instructions).</p>	<p>To set:</p> <ol style="list-style-type: none"> <li>1. Touch "CLEAR/STOP".</li> <li>2. Touch "DEFROST".</li> <li>3. Touch time key(s) for desired defrost time.</li> <li>4. Touch "START".</li> </ol> <p>(See page 13 for more detailed instructions).</p>	<p>To set:</p> <ol style="list-style-type: none"> <li>1. Touch "CLEAR/STOP".</li> <li>2. Touch "DELAY COOK".</li> <li>3. Touch "HOUR" and "MINUTES" keys for the time of day to start cooking.</li> <li>4. Touch "POWER" and select desired power level.</li> <li>5. Touch time key(s) for desired cooking time.</li> <li>6. Touch "START".</li> </ol> <p>(See page 12 for more detailed instructions).</p>

# "High Power" and Variable Power" Cooking

1. Touch "**CLEAR/STOP**" and a beep tone will be heard. (This erases all previous settings and is not always necessary).
2. Touch "**POWER**" and select the desired power level by holding your finger on the "**POWER**" pad. To stop at the desired power level simply remove your finger from the "**POWER**" pad. The lights above the corresponding power level and below stage light "1" will go on. "0" will appear in the display window.
3. Touch the time on control panel to set the cooking time. The time set will appear in the display window at the top of the control panel.

For example:

- To set 30 seconds, touch "30sec".
  - To set 3 minutes, touch "2min", and "1min".
  - To set 10 minutes, touch "5min" and "5min" again.
4. Touch "**START**". The oven will begin cooking and the display window will show the time counting down in minutes and seconds. A tone will sound for 2 seconds when the cooking is complete. The oven switches itself off. The time of day will reappear in the display window.

**NOTE:** If your wish to stir or re-arrange food during cooking: simply open the oven door; stir or re-arrange; close door; touch; "**START**"; and the oven will automatically continue to count down the remaining amount of time left on display.

Example: 900g/2 lb Fresh lamb can be cooked quickly on "**MH**" for 20 minutes. To do this follow these 4 simple steps.

1. Touch "**CLEAR/STOP**".
2. Touch "**POWER**" and select Power Level.

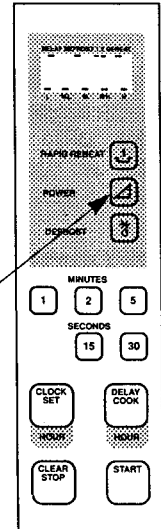

3. Set 20 minutes by touching "5min" 4 times. "20:00" will appear in the display window.

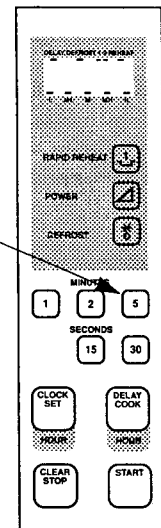

4. Touch "**START**". The oven will begin cooking and the display window will show the time counting down in minutes and seconds. A tone will sound for 2 seconds when the cooking is complete. The oven switches itself off. The time of day will reappear in the display window.

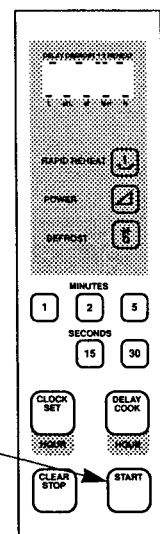



# "Variable Power" Setting Guide

Variable power lets you cook foods at the most suitable power level.

POWER LEVEL	SUGGESTED USE
<b>"L"</b> 80W LOW (10%)	Softening cream cheese. Melting small quantities of chocolate. Defrosting frozen pastry.
<b>"ML"</b> 150W MEDIUM LOW (25%)	Keeping food warm. Thawing meat, poultry and seafood. Low simmer for some casseroles and stews.
<b>"M"</b> 300W MEDIUM (50%)	Completing the cooking cycle of pot roasts. Medium simmer for some casseroles and stews. Baked custards and cheesecakes.
<b>"MH"</b> 450W MEDIUM HIGH (70%)	Roasting meats. Baking cakes.
<b>"H"</b> 650W HIGH (100%)	Boiling liquids. Cooking poultry, fish, vegetables. Sauteing vegetables. Reheating foods. Preheating a browning dish.
<b>RAPID REHEAT</b> 850W	Boiling liquids. Reheating foods. Preheating a browning dish.

## Re-heating cook-chilled foods

- The food manufacturer's cooking time should be used as a guide only. If, when the stated cooking time has expired, the food isn't piping hot, return it to the oven and cook it until it is, in much the same manner as you would when cooking with a conventional oven.
- Always stir food regularly, particularly sauces and casseroles.
- Standing time is very important, it is part of the cooking process and also allows an even temperature throughout the food.

# "Two Stage" Cooking

Two stage cooking is ideal for sequential cooking, it lets you cook at a different power level for a chosen time. Set all stages before cooking and start the oven and commence cooking.

1. Touch "CLEAR/STOP".
2. Touch "POWER" and select 1st stage power level. The indicator lights of the corresponding power level and below stage light "1" will go on and "0" will appear in the display window.
3. Touch the time key(s) on control panel to set 1st stage cooking time. The time will show in the display window. (The first stage cooking has now been set.)
4. Touch "POWER" and select desired 2nd stage power level. The lights above the corresponding power level and below stage "2" will go on and "0" will appear in the display window.
5. Touch time key(s) to set 2nd stage cooking time. 2nd stage cooking time will appear in the display window.
6. Touch "START".

Example: (Two-Stage Cooking)

A beef casserole requires 2 stages of cooking.

## FIRST STAGE

(10 minutes: "H")

1. Touch "CLEAR/STOP".
2. Touch "POWER" and select power level "H".

3. Set 10 minutes by touching "5min" twice. "10.00" will show in the display window. (The first stage has now been set).

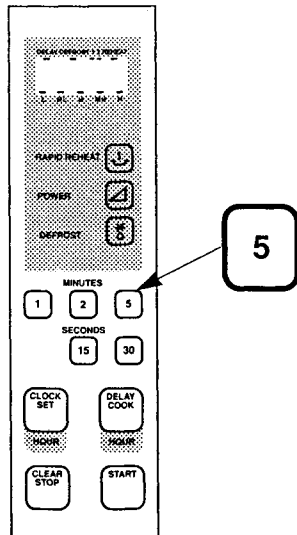
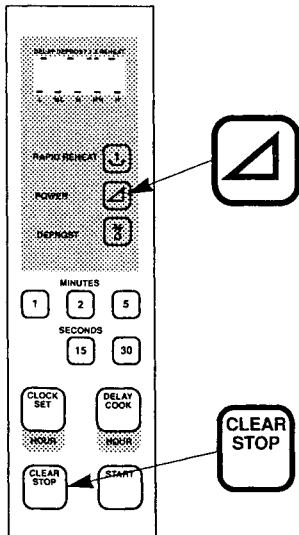

## SECOND STAGE

(60 minutes, "M" MEDIUM).

4. Touch "POWER" and select power level "M".
5. Set 60 minutes by touching "5min" twelve times. "60.00" will show in the display window. (The second stage has been set.)

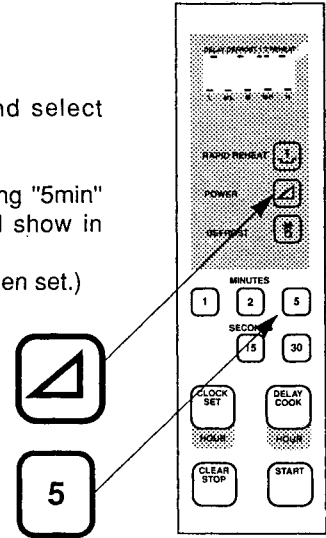

6. Touch "START".

The first stage will begin.

"10.00" will show in the display window. The oven will begin to cook and the time can be seen counting down in the display window. When the 10 minutes are over, a tone will sound and the oven will automatically change into the second stage. The oven will begin cooking at "M" power and the time will be counting in the display window. When the second cooking time is over, a tone will sound and the oven will automatically shut off. The time of day will reappear in the display window.

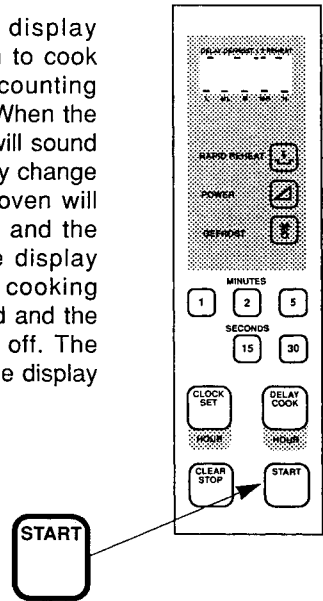

# "Rapid Reheat" Cooking

You can cook for 1 minute, 2 minutes, 5 minutes, 15 seconds and 30 seconds by using the "Rapid Reheat" function for max. power 850W cooking. The benefit of this function is that you need touch only one time key on the control panel.

1. Touch "**CLEAR/STOP**" and a beep tone will be heard. (This erases all previous settings and is not always necessary).
2. Touch "**RAPID REHEAT**" indicator light will go on and "P850" will show in the display window.
3. Touch the appropriate time on the control panel to set the cooking time. The time set will show in the display window, and the oven will automatically start.

The oven will begin cooking and the display window will show the time counting down in minutes and seconds. A tone will sound for 2 seconds when the cooking is completed. Then the oven shuts itself off.

Example: Bacon (6 slices) can be cooked quickly on "**RAPID REHEAT**" 850W for 5 minutes. To do this follow these 3 simple steps.

1. Touch "**CLEAR/STOP**".
2. Touch "**RAPID REHEAT**".

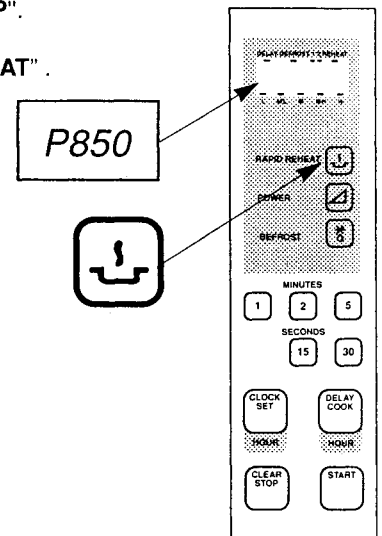

3. Touch "5min."  
The oven will begin to cook and the time will begin to count down in the display window. A tone will sound for 2 seconds when the cooking is over, and the oven will shut itself off.

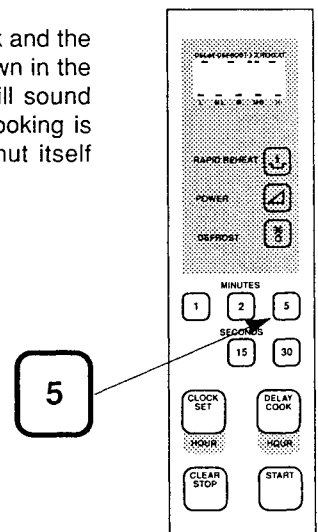

# "Delay Start" Cooking

This oven can be programmed to begin cooking automatically at a pre-set Time of Day.

1. Touch "**CLEAR/ STOP**".
2. Touch "**DELAY COOK**". The light below "**DELAY COOK**" goes on. "0.00" will show in the display window.
3. Touch the **HOUR** and **MINUTE** keys for the time of day to start cooking.  
For example, set "7" with key **HOUR** and "30" with key **MINUTE** for the cooking to be started at "7:30", and "7:30" will show in the display window.

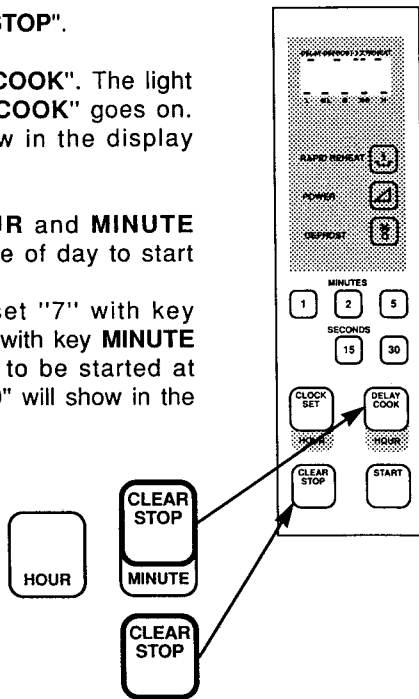

6. Touch "**START**". The current Time of Day (6:30) will show in the display window. When the **COOK START TIME** (ex. 7:30) is reached, the oven will begin cooking automatically.

The oven will shut off when cooking is complete.  
The time of day will reappear in the display window.

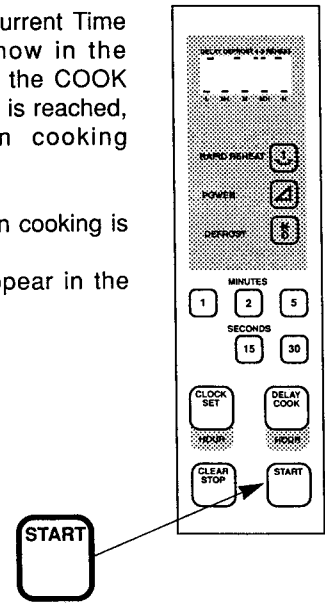

## NOTE:

A preset delay time must be less than 24 hours.  
Three Stage Cooking can be used with Delay Start.

- "Weight Defrost" and "Weight Reheat" (Frozen Convenience Food), Auto Reheat and Auto Cook cannot be used with Delay Start.
- Fresh food should not stand at room temperature for over 4 hours prior to cooking.

4. Touch "**POWER**" and selected desired power level.
5. Touch the time key(s) to set cooking time (e.g. **M**, 15 mins).

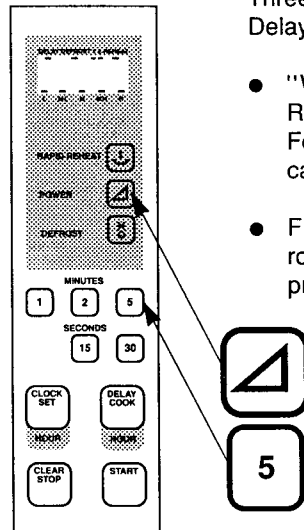

# Programmed Defrost

This special setting has been designed to cut down defrosting time. The oven operates on "H" (HIGH) for the beginning of the chosen time and at "ML" for the remaining period of time.

1. Touch "**CLEAR/STOP**" and a beep tone will be heard. (This erases all previous settings and is not always necessary).
2. Touch "**DEFROST**". The lights below "**DEFROST**" and "1" will go on. "0" will show in the display window.
3. Touch time key(s) for defrosting time. (See "Programmed Defrost" chart for timings).
4. Touch "**START**". The oven will begin defrosting and the display window will show the time counting down in minutes and seconds. A tone will sound for 2 seconds when the defrosting has finished. The oven switches itself off. The time of day will reappear in the display window.

Example: To defrost 450g/1lb minced beef using the programmed defrost cycle for 7 minutes.

1. Touch "**CLEAR/STOP**".
2. Touch "**DEFROST**".

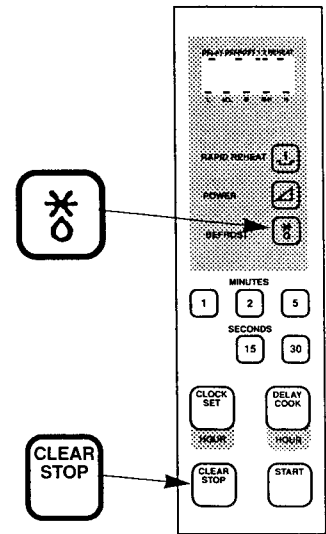

3. Set 7 minutes by touching "5min" and "2min" "7.00" will show in the display window.

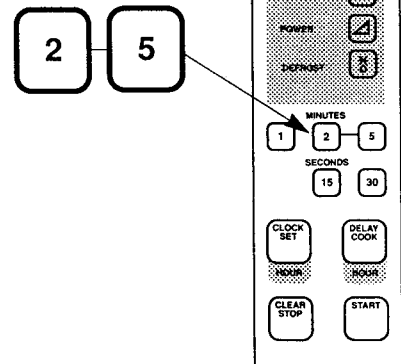

4. Touch "**START**". The oven will begin defrosting and the display window will show the time counting down in minutes and seconds. A tone will sound for 2 seconds when the defrosting has completed. The oven switches itself off. The time of day will reappear in the display window.

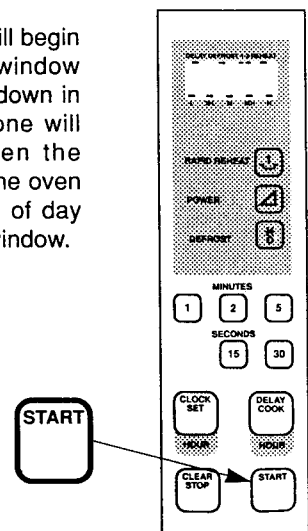

# “Programmed Defrost” Chart

## TIPS FOR DEFROSTING

- Place meat and poultry on an upturned saucer onto a plate or on a microwave rack.
- Metal ties and clips on poultry should be removed.
- Poultry pieces and meat chops should be arranged like the spokes of a wheel with the thinner ends towards the centre.
- Fish, seafood, meat or poultry should be removed from their original package.
- Food should be arranged in a single shallow layer where possible.
- When stirring for J; move food from the outside to centre and vice versa.
- Food should be icy when defrosting time has finished.
- Standing time is necessary to complete the thawing process.
- Cook defrosted food as soon as possible.

CUT AND WEIGHT	PROGRAMMED DEFROST TIME IN MINS	STANDING TIME IN MINS	DIRECTIONS
<b>FISH AND SEAFOOD</b>			
Fillets 450g/1 lb 900g/2 lb	5—6 8—9	5 5	Carefully separate Carefully separate
Whole fish 450g/1 lb 900g/2 lb	3—4 5—7	5 5	Protect head and tail with foil Protect head and tail with foil
Scallops 225g/1 lb 450g/1 lb	3 5—6	5 5	Stir halfway through defrosting Stir halfway through defrosting
Prawns 225g/ 8 oz 450g/1 lb	3—4 5—6	5 5	Stir halfway through defrosting Stir halfway through defrosting
<b>MEAT</b>			
Beef Brisket 450g/1 lb	6—7	20—30	Turn over halfway through defrosting
Topside, silverside 450g/1 lb	5—6	20—30	Turn over halfway through defrosting
Rib of beef 450g/ lb	6—7	20—30	Turn over halfway through defrosting
Steak 450g/1 lb	6—7	15	Separate as soon as possible

# “Programmed Defrost” Chart (Cont'd)

CUT AND WEIGHT	PROGRAMMED DEFROST TIME IN MINS	STANDING TIME IN MINS	DIRECTIONS
<b>MEAT</b>			
Minced Beef 450g/1 lb	6—7	5—10	Separate as it is thawing and remove thawed portions
Cubed beef 450g/1 lb	6—7	10—15	Stir once
Lamb Leg, shoulder saddle 450g/1 lb	7—8	20—30	Turn over halfway through defrosting Shield thin ends and bone with foil
Chops 450g/1 lb	6—7	10	Separate as soon as possible
Pork Leg, shoulder loin 450g/1 lb	7—8	20—30	Turn over halfway through defrosting
Sausages 450g/1 lb	4—5	5	Separate as soon as possible
Spareribs 900g/2 lb	13—14	5—10	Separate as soon as possible
Bacon 225g/8 oz 450g/1 lb	2 3—4	5 5	
Liver 225g/8 oz 450g/1 lb	3—4 5—6	5—10 5—10	Separate as soon as possible Separate as soon as possible
Kidney 225g/8 oz 450g/1 lb	3—4 5—6	5—10 5—10	Separate as soon as possible Separate as soon as possible
<b>POULTRY</b>			
Chicken	6—7	30—40	Shield legs and breast with foil to prevent over-defrosting, turn over once.
Thighs, wings, legs 450g/1 lb	7—8	10	Separate as soon as possible and arrange thin areas with foil
Breast, bone-in 450g/1 lb	7—8	15	Separate
Duckling 450g/1 lb	7—8	45	Turn over once

## “Programmed Defrost” Chart (Cont'd)

CUT AND WEIGHT	PROGRAMMED DEFROST TIME IN MINS	STANDING TIME IN MINS	DIRECTIONS
Turkey Breast, bone-in 450g/1 lb	5—7	10—15	Shield thin parts with foil
Leg and thigh 450g/1 lb	8—10	20	Shield thin parts with foil
Whole 450g/1 lb	6—7	60	Turn over once
<b>FRUIT</b>			
Strawberries 225g/8 oz 450g/1 lb	3—4 5—6	5 5	Stir during defrosting Stir during defrosting
Raspberries, black berries 225g/8 oz 450g/1 lb	3—4 6—7	5 5	Stir during defrosting Stir during defrosting
Redcurrants and black currants 225g/8 oz 450g/1 lb	3—4 6—7	5 5	Stir during defrosting Stir during defrosting
<b>BREAD</b>			
Loaf, whole (large)	7—8	10—15	Place on a rack or kitchen paper, turn over during defrosting
Loaf, whole (small)	5—6	10—15	Place on a rack or kitchen paper, turn over during defrosting
Loaf, sliced (large)	6—7	10—15	Remove from original wrapper, turn over once during defrosting and remove outer slices if thawed
Loaf, sliced (small)	4—5	10—15	Remove from original wrapper, turn over once during defrosting and remove outer slices if thawed



# How to Use Your Microwave Oven Safely (Important)

Although your oven is provided with safety features, it is important to observe the following:

- a) It is important not to defeat or tamper with safety interlocks.
- b) Do not place any object between the oven and the door or allow residue to accumulate on sealing surfaces. Wipe the sealing area frequently with a mild detergent, rinse and wipe dry. Never use abrasive powders or pads.
- c) When opened, the door must not be subjected to strain, for example, a child hanging on an opened door or any load could cause the oven to fall forward causing injury and also damage to the door.

Do not operate the oven if it is damaged, until it has been repaired by a service engineer trained by Tricity Bendix. It is particularly important that the oven closes properly and that it is inspected for damage to the

- i) Door (bent)
  - ii) Hinges and Latches (broken or loosened)
  - iii) Door seals and Sealing surfaces (broken, dented or incomplete).
- d) It is dangerous for anyone other than a properly qualified service engineer to carry out adjustments or repairs. See Service page for details of how to arrange a service call.
  - e) Small quantities of food or foods with low moisture content or high fat or sugar content can burn, dry out or catch on fire if cooked or re-heated too long.  
Please note that the heating/cooking period required for such food is extremely short: for example it only takes approximately 15 seconds to heat one mince pie or similar. In the unlikely event of a fire occurring, turn off the oven and its electrical supply, pull out the plug, but keep the oven door closed.

## WARNING

1. Do not heat foods or liquids in bottles or jars with lids on. Air must be allowed to escape from the container.
2. Milk or food for babies should be heated on MEDIUM, "M". It should then be stirred thoroughly and the milk or food should be tested to ensure that it is at the correct temperature before giving it to the baby. Do not use this oven to warm infant food or milk once it is in the feeding bottle.
3. When boiling water or other liquids, be sure to use a wide mouthed container. This will allow air bubbles to escape freely. Should a narrow mouthed container be used, air bubbles may combine to form a large bubble which may in turn cause the liquid to boil over. This may happen even after the cooking time has stopped.
4. Do not attempt to operate the oven while empty as this will cause damage to the appliance.
5. Care should be taken not to obstruct any air vents located on the rear, side and bottom of the microwave oven.

## Taking Care of Your Microwave Oven

Wipe the oven inside and out with a mild detergent solution, rinse, and wipe dry. This should be done on a weekly basis — more often if needed. Never use abrasive powders or pads.

### REMOVABLE PARTS

- The glass turntable can be removed for cleaning at the sink. Wipe up any spillage with paper towel or cloth prior to removal of turntable.
- The interior lamp can be replaced by unscrewing the small cover on the back side of the oven. The lamp is a screw fitting, 240 volts 25 watts (E14).

### LAMP REPLACEMENT INSTRUCTION:

First of all, pull the plug out of the socket. On the rear side of the microwave oven, you will find the lamp cover which you have to remove in order to replace the defective lamp.

You need a screw driver (Phillips type). The lamp is secured with a tape: Having removed this tape you can take out the defective lamp and insert the new one. The tape is just for transportation-locking.

After replacement you must re-fit the lamp cover and secure it with the screw driver.

Only NOW can you connect the set to the mains again by putting the plug into the socket.

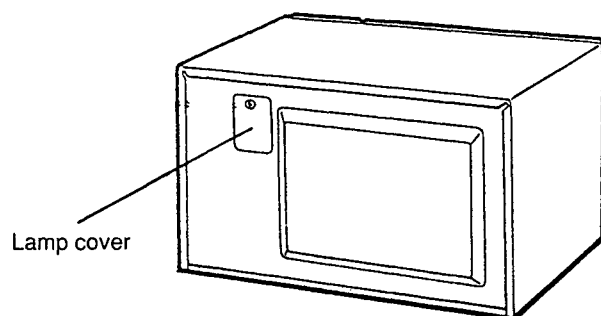

# Usable Cooking Utensils and Materials

## OVENPROOF GLASS

Ovenware (treated for high-intensity heat), such as mixing bowls, bread dishes, pie plates, cake plates, liquid measuring cups, casseroles, and bowls without metallic decoration.

## CHINA

Bowls, cups, serving pieces, plates and platter without metallic decoration.

## POTTERY

Dishes, cups, mugs, and bowls.

## PLASTIC

Microwave plastic film may be used as a cover, but as the food heats up it may cause the film to melt wherever it touches the food. Therefore the dish should be deep enough so that the cling film does not touch the food. Also the film should be pierced to allow steam to escape. Plastic dishes, cups, semi rigid freezer containers, and plastic bags are usable for short cooking operations. Use with care as some softening of the plastic can occur with heat from the food.

## ALUMINIUM FOIL

Small smooth pieces may be used to shield bones or narrower ends of poultry, meat or fish for part of the heating or cooking time to prevent overcooking. Care should be taken to ensure the foil is smoothed tightly around the ends. By using aluminium foil in this way you are in fact preventing the microwaves from reaching that are of the food as they are reflected from metal, thus slowing down the heating time. Foil should not be allowed to touch the sides, rear, door or top of the cooker as this may cause damage to the cavity.

## SHALLOW ALUMINIUM FOIL CONTAINERS

These may be used with care providing the following rules are closely followed.

1. Where possible products should be covered with a fitted microwave transparent lid. Where other microwaveable covering or no lid is fitted, users should stir the product immediately it is defrosted and halfway through the heating cycle.  
Foil board lids must not be used and must always be removed before heating in the microwave oven.
2. Place container in the centre of the oven on a non-metallic, heat resistant tray or glass turntable. If a turntable is fitted which is not suitable, place the container on an ovenable plate or microwave insulating tray.
3. Products in aluminium foil containers must be reheated singly in the microwave oven.
4. Aluminium foil containers must not be more than 32mm (1 1/4in) deep. Shallow containers with a large surface area give best results.
5. Do not place an empty foil container in a microwave oven. The container must be at least 2/3rds full.
6. If the microwave oven has been used to reheat a product for more than 15minutes allow the turntable to cool before using again.
7. Care should be exercised when removing any lid or covering from heated food, as hot steam may escape.
8. Containers and turntables absorb microwave energy and therefore heat up. Whatever the container used, using oven gloves is a sensible precaution.
9. Remember when using aluminium foil containers that the cooking or reheating times will be extended, always ensure that the food is heated thoroughly and is piping hot throughout before serving.
10. DO NOT RE-USE ALUMINIUM FOIL CONTAINERS IN THE MICROWAVE OVEN.

# Utensils and Materials to Avoid

## METAL UTENSILS

Metal utensils are not recommended because the metal shields the food from microwave energy on the bottom and sides, causing uneven cooking results. Metal utensils will also cause arcing and damage the appliance.

## METAL DECORATION

Metal-trimmed or - banded dinnerware, casseroles, etc., should not be used. The metal trim interferes with normal cooking and may damage the dish.

## ALUMINIUM FOIL

Large sheets or pieces of aluminium foil should be avoided because they will disrupt cooking and may cause harmful arcing. However, smaller pieces may be used to cover areas

such as poultry legs and wings. Any aluminium foil used should never be closer than 2.5cm (1 inch) from side walls of oven.

## WOOD

Wooden bowls and boards, will become dried out when used in the microwave oven and may split or crack.

## OTHER

Avoid using cracked, flawed, or defective utensils, including ovenproof glassware.

CAUTION: DO NOT USE METAL TIES ON ANY PAPER OR PLASTIC BAGS; THE TIES BECOME HOT AND COULD CAUSE A FIRE.

# What to Do If Repairs Are Needed

Get in contact with your nearest Tricity Bendix Service Centre. On no account remove or interfere with any part or screws, with the exception of the interior lamp door. "THIS COULD PROVE VERY DANGEROUS".

Make the following simple check-up before contacting the Tricity Bendix Service Centre:

- If the interior lamp does not light when the "START" pad is touched.
  1. Make sure that the mains lead is securely plugged in.
  2. Make sure that the door is properly closed.
  3. Check the fuse in the plug top and ensure the plug top is wired correctly.
- If the lamp inside lights but the food is not heated:

Make sure that the food is not completely covered with a metal container.
- Noisy operation:

Make sure that sparks are not being produced due to the use of metal utensils.

## A Few Other Precautions (Important)

1. Arcing in the oven during operation usually occurs from use of metallic utensils or overuse of aluminium foil. Arcing is denoted by a "snapping" or "cracking" noise and may be accompanied by bright flashes.

Continuous arcing can damage the unit. If continuous arcing occurs during operation, do not use the unit and call a service engineer.
2. Always make sure that closed containers, such as jars of baby food, are opened and plastic pouches for vegetables are pierced before cooking.

Tightly closed containers could explode.
3. Do not cook eggs in their shells because they will explode. Puncture the membrane around the yolk before frying eggs.

This is because the yolk swells faster than the membrane and the egg explodes when heated quickly.
4. Do not be alarmed or surprised if you notice the turntable moving clockwise sometimes, and anticlockwise at other times. There is nothing wrong with your oven it is merely the type of turntable motor we use.
5. Small quantities of food with low moisture content or high fat or sugar content can burn, dry out or catch on fire if cooked or re-heated too long.

Please note that the heating/cooking period required is extremely short: for example it only takes approximately 15 seconds to heat one mince pie or similar.  
In the unlikely event of a fire occurring, turn off the oven and its electrical supply, pull out the plug, but keep the oven door closed.
6. **WARNING**

When heating liquids in your microwave oven, overheating the liquid beyond boiling point can occur without the evidence of bubbling, this could result in overspill of the hot liquid and possible injury to the user. To help prevent this possibility the following tips should be observed.

  1. Stir the liquid before placing the container in the oven and once again during the heating time.
  2. At the end of the heating time allow the liquid to cool slightly before stirring again and removing the container from the oven using an oven cloth for added protection.

## Electrical Appliance Guarantee (Warranty)

Note: Nothing in this express warranty affects the statutory rights available to the consumer.

Tricity Bendix (the Company) WARRANTS to the user that if this Microwave Oven (the Product) is or becomes defective and the defect results from faulty materials and/or workmanship and not in any way from accident, misuse or mishandling by the user, the Company shall, at its sole option, repair or replace such defective Product or part thereof free of charge on the following basis:—

- 1) in the case of components parts (other than the "Magnetron" unit) and of workmanship — for a period of 12 months from the date of purchase by the user: and
- 2) in the case of the "Magnetron" unit — for a period of 24 months from the date of purchase by the user; (part only).
- 3) provided that the glass tray and light bulbs shall be excluded absolutely from this warranty.

The dealer's retailer's dated bill of sale or delivery ticket shall be evidence of the date of purchase.

This Warranty is valid in the United Kingdom only and is not transferable.

The Warranty shall be null and void if the Product is tampered with, misused or abused, or if the serial number is defaced or removed.

### IMPORTANT NOTICE:

This model in the Tricity Bendix range of Microwave Ovens is recommended to DOMESTIC USE ONLY. Its use in a commercial capacity will render this guarantee inoperative.

To obtain service under guarantee, you are advised to contact your Tricity Bendix Service Centre or the dealer from whom the product was purchased or the Customer Care Department by telephone or letter:-

TRICITY BENDIX  
99, Oakley Road,  
Luton,  
Beds LU4 9QQ

Telephone: 0582 494000

# TRICITY BENDIX Service Centres

Service Centre	Postcode areas covered	Telephone	Address
ABERDEEN	DD IV KW AB PH	0224 696569	8 Cornhill Arcade, Cornhill Drive, Aberdeen AB2 5UT
BELFAST	BT	0232 746591	Unit C3, Edenberry Industrial Estate, 326 Crumlin Road, Belfast BT14 7EE
BIRMINGHAM	WR DY B WV TF ST WS	012 358 7076	8 Lammermoor Ave. Great Barr, Birmingham B43 6ET
BRISTOL	(BA BS SN TA) (TQ EX TR PL)	0272 211876 0626 65909	3 Waring House, Redcliffe Hill, Bristol BS1 6TB
CANVEY ISLAND	RM CM SS CO IG	0268 694144	Canvey Centre, 2-2 Sandhurst, Kings Road, Canvey Island SS8 0QY
CARDIFF	CF HR LD NP SA	0222 460131	Guardian Industrial Estate, Clydesmuir Road, Tremorfa, Cardiff CF2 2QS
GLASGOW	DG KA ML G PA KY EH TD FK	041 647 4381	20 Cunningham Road, Clyde Estate, Rutherglen, Glasgow G73 1PP
LEEDS	S DN HU YO WF HX HD LS HG BD	0532 608511	64-66 Cross Gates Road, Leeds LS15 7NN
LEICESTER	LE DE CV NG LN PE IP NR	0533 515131	10-12 Buckminster Road, Leicester LE3 9AR
LIVERPOOL	CW CH LL L WA	051 254 1724	Unit 1, Honeys Green Lane, West Derby, Liverpool L12 9JR
LONDON (NORTH)	E EC WC N NW W EN	081 443 3464	London North Centre, 2-4 Sandhurst, Kings Road, Canvey Island SS8 0QY
LONDON (SOUTH)	SE SM CR BR SW	081 658 9069	London South Centre, 2-4 Sandhurst, Kings Road, Canvey Island SS8 0QY
LONDON (WEST)	AL CB LU MK SG WD HA UB TW	081 965 9699	London West Centre, 2-4 Sandhurst, Kings Road, Canvey Island SS8 0QY
NEWTON AYCLIFFE	(CA DL DH NE SR TS) (SK M BL OL BB LA FY PR WN)	0325 301400 0282 746214	PO Box 40 Preston Road, Aycliffe Industrial Estate, Newton Aycliffe, Co. Durham DL5 6XL
OXFORD	GI HP NN OX SI RG	0993 704411	Suite 3, Windrush Court, 56a, High Street, Witney OX8 6BL
PORTSMOUTH	BR DT PO SO SP KT GU	0705 667411	Umberline Road, Hilsea, Portsmouth PO3 5JJ
TONBRIDGE	(CT DA ME TN) (BN RH)	0732 357722 0273 694341	61-63 High Street, Tonbridge TN9 1SD

**TRICITY BENDIX**  
we'll do the homework

Tricity Bendix Limited, 99 Oakley Road, Luton, Beds, LU4 9QQ.

Model No.  
**IM 900**

Part No.  
**432-6-413S-53800**

## Free Manuals Download Website

<http://myh66.com>

<http://usermanuals.us>

<http://www.somanuals.com>

<http://www.4manuals.cc>

<http://www.manual-lib.com>

<http://www.404manual.com>

<http://www.luxmanual.com>

<http://aubethermostatmanual.com>

Golf course search by state

<http://golfingnear.com>

Email search by domain

<http://emailbydomain.com>

Auto manuals search

<http://auto.somanuals.com>

TV manuals search

<http://tv.somanuals.com>