

TRICITY BENDIX

*OPERATING & INSTALLATION
INSTRUCTIONS*

GAS COOKER

SIG 233/1

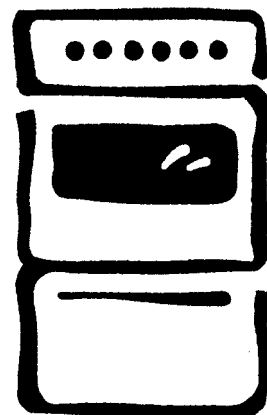

GB

CONTENTS

Instructions for the User

Warnings	4
Use and care	5
Use of the appliance	6
Using the Oven	6
Using the Grill	8
Using the Hob	9
Hints and tips	12
Maintenance and cleaning	13
Oven bulb replacement	14
Something Not Working	15
Service and spare parts	16
Guarantee Conditions	17

Instructions for the Installer

Technical Features	18
Advice for safety	19
Gas connection	19
Electrical connections	20
Installation	21
Gas connection	22
Conversion of gas	24

How to read the instruction book?

The symbols below will guide you when reading the instruction book



Safety instructions



Description of operations step by step



Advice and recommendation



Information environment protection

IMPORTANT SAFETY INFORMATION



You MUST read these warnings carefully before installing or using the appliance. If you need assistance, contact our Customer Care Department on 08705 950950.

Installation

- This cooker must be installed by qualified personnel, according to the manufacturer's instructions and to the relevant British Standards.
- This cooker is heavy. Take care when moving it.
- Any gas installation must be carried out by a registered CORGI installer.
- Any electrical installation must be carried out by a qualified electrician/competent person.
- Remove all packaging before using the cooker.
- This cooker must not be connected to a combustion products evacuation device. It shall be installed and connected in accordance with current installation regulations. Particular attention shall be given to the relevant requirements regarding ventilation.
- This cooker is designed to be connected to a 230-240V, 50Hz electrical supply.
- Ensure that the gas and electrical supply complies with the type stated on the rating plate, located near the gas supply pipe.
- Do not attempt to modify the cooker in any way.

Child Safety

- This cooker is designed to be operated by adults. Do not allow children to play near or with the cooker.
- The cooker gets hot when it is in use. Children should be kept away until it has cooled.
- Children can also injure themselves by pulling pans or pots off the cooker.

During Use

- This cooker is intended for domestic cooking only. It is not designed for commercial or industrial purposes.
- When in use a gas cooker will produce heat and moisture in the room in which it has been installed. Ensure there is a continuous air supply, by keeping air vents in good condition or installing a cooker hood with a venting hose.
- When using the cooker for a long period time, the ventilation should be improved, by opening a window or increasing the extractor speed.
- Do not use this cooker if it is in contact with water. Do not operate the cooker with wet hands.
- The grill pan will become hot during use, always use oven gloves when removing or replacing a hot grill pan.

- Ensure the control knobs are in the 'OFF' position when not in use.
- When using other electrical appliances, ensure the cable does not come into contact with the hot surfaces of the cooker.
- Unstable or misshapen pans should not be used on the hob burners as unstable pans can cause an accident by tipping or spillage.
- Never leave the cooker unattended when cooking with oil and fat.
- Never pull the appliance by the oven handle.
- This cooker should be kept clean at all times. A build-up of fat or foodstuff could result in a fire.
- Never use steam or high pressure appliances for cleaning the oven.
- Never use plastic dishes in the oven or on the hob burners. Never line any part of the oven with aluminium foil.
- Always ensure that the oven vent, which is located at the centre back of the hob, is left unobstructed to ensure ventilation of the oven cavity.
- Perishable food, plastic items and aerosols may be affected by heat and should not be stored above the cooker.
- The appliance is fitted with a lid: this is designed as a dust cover when closed, and as a splash back when open. Do not use for any other purpose.
- Always remove any spillage from the surface of the lid before opening, and the appliance should be allowed to cool before closing the lid.
- After using the cooker, the lid **MUST NOT** be closed until the hob and oven are completely cold.

Service

- This cooker should only be repaired or serviced by an authorised Service Engineer and only genuine approved spare parts should be used.

Environmental Information

- After installation, please dispose of the packaging with due regard to safety and the environment.
- When disposing of an old appliance, make it unusable, by cutting off the cable.

Keep this instruction book for future reference and ensure it is passed on to any new owner.

INSTRUCTIONS FOR THE USER

USE AND CARE

Control panel

Models: SIG 233/1W, SIG233/1B

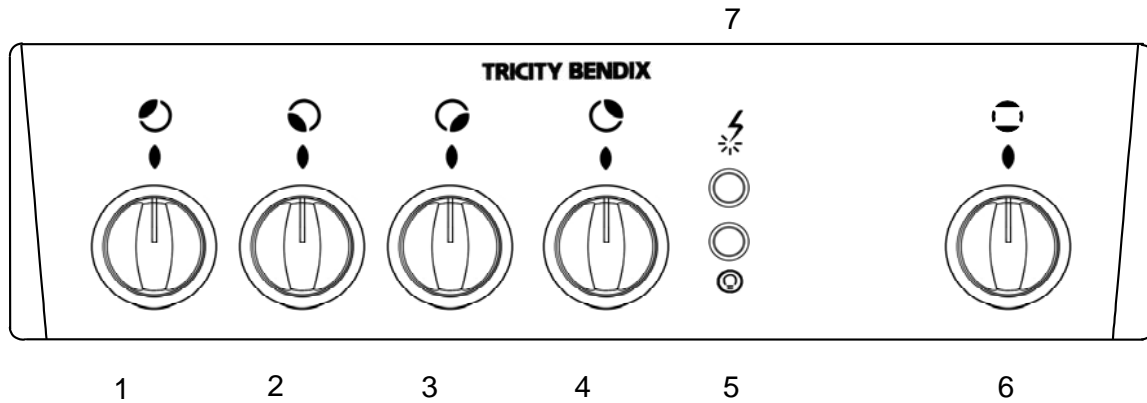

1. Back left burner control knob
2. Front left burner control knob
3. Front right burner control knob
4. Back right burner control knob
5. Oven light
6. Oven/Grill burner control knob (selector)
7. Ignition switch

Hob

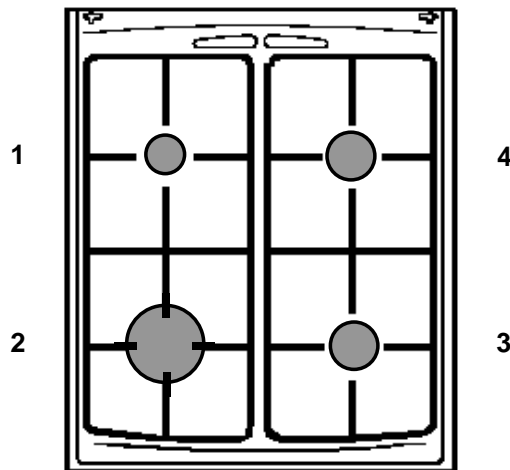

1. Back left burner (auxiliary)
2. Front left burner (rapid)
3. Front right burner (semi-rapid)
4. Back right burner (semi-rapid)

USE OF APPLIANCE

Before the First Use of the Cooker

 **Remove all packaging both inside and outside of the cooker, before using it.**

Before first use, the oven should be heated without food. During this time, an unpleasant odour may be emitted. This is quite normal.

1. Remove the oven accessories and ensure all packaging has been removed.
2. Ignite the oven burner (see instructions) and turn the control knob to maximum.
3. Open a window for ventilation.
4. Allow the oven to run empty for approximately 45 minutes.

This procedure should be repeated with the grill function for approximately 5-10 minutes.

Using the Oven

 **The cooker gets hot when it is in use. Children should be kept away until it has cooled.**

Stand clear when opening the drop down oven door. Do not allow it to fall open - support the door using the door handle, until it is fully open.

When using the oven the lid must be open to avoid over-heating.

Attention: when turning on the oven and grill burner the oven door has to be opened.

The oven has four shelf levels, and is supplied with one shelf.

The shelf positions are counted from the bottom of the oven as shown in the diagram.

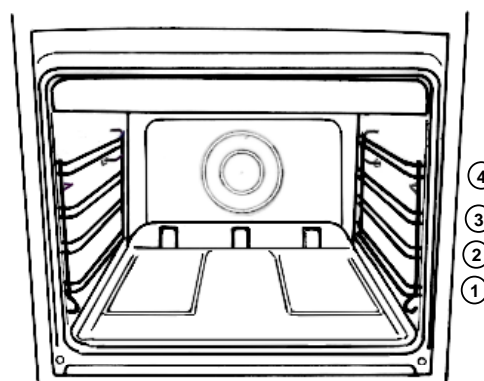

Oven Safety device

The cooker features a thermocouple; if for any reason the flame should extinguish, the device will stop the gas flow.

Use

The oven can be used for traditional cooking, or for grilling, but not both functions simultaneously. The symbol on the knob corresponds to the symbol on the control panel.

- Off
- “8” Maximum
- “1” Minimum
-  Grill function

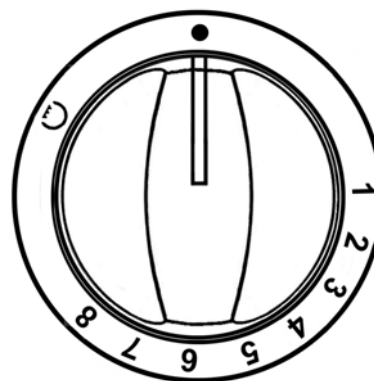

Ignition



Attention: when turning on the oven and grill burner the oven door has to be opened.

- Open the oven door, push and turn the control knob to the left to position 8, **keeping the control knob pressed.**
- **At the same time, push the electronic ignition knob** (see fig). Keep it pushed until the gas ignites (1 spark / second).
- **Release the knob after 10 seconds** and check that the burner is ignited through the holes in the burner cover.

OR

During a power cut

- Open the oven door, push and turn the control knob to the left to position 8, and hold a flame near the hole in the bottom;
- **Release the knob after 10 seconds** and check that the burner is ignited through the holes in the burner cover.

If for any reason the flame should extinguish turn the control knob to the off position, after at least 1 minute, try to re-ignite the oven.

To adjust the flame, turn the oven knob to the position corresponding to the temperature desired, after a few minutes of operation.



Turning off the oven burner

Turn the knob clockwise to mark « ● ».

Cooking in the Oven

Traditional cooking is made by natural convection; the heated air circulates on the principle of ascending and descending draughts. It is necessary to pre-heat the oven.

All cookers vary and it is important to be aware of the approximate cooking temperatures before you use the cooker.

It may be necessary to adjust the temperature to suit your individual requirements. Only experience will enable you to determine the correct setting for your personal requirements.

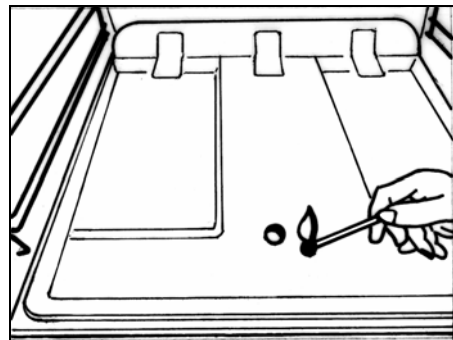
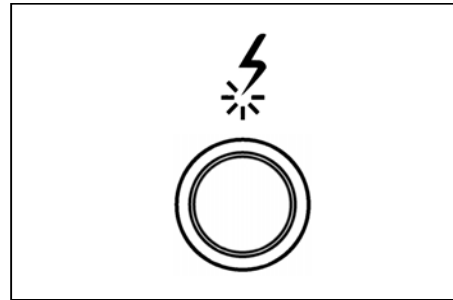

Using the Grill

 When grilling, the accessible parts of the appliance are hot and the appliance should not be left unattended. Take care that children do not play near it. While the grill is operating leave the oven door half open and put the grill deflector "A" into place.

Grill burner ignition

 **Attention: when turning on the oven and grill burner the oven door has to be opened.**

- **Open the oven door** push and turn the control knob to the right to the "grill symbol" and keep the control knob pressed.
- **At the same time, push the electronic ignition knob** (see fig). Keep it pushed until the gas ignites (1 spark / second).
- **Upon ignition, keep the knob pressed for approximately 10 seconds** (until the safety valve automatically keeps the grill burner lit).

OR

During a power cut

- Open the oven door.
- Hold a flame to the gas grill burner holes (see fig.).
- Press the oven/grill function control knob, then turn it to the "grill symbol". **Upon ignition, keep the knob pressed for approximately 10 seconds** (until the safety valve automatically keeps the grill burner lit).

If for any reason the flame should extinguish turn the control knob to the "●" position, leave for at least 1 minute and then re-ignite.

 **The grill pan will become hot during use, always use oven gloves when removing or replacing a hot grill pan.**

Grilling

 **When using the grill it has to be supervised, the oven door opened and the grill deflector "A" in its place.**

When grilling, only the top burner is heating. It is not necessary to preheat the grill.

- Insert the grill pan on the fourth level.
- Turn the knob to position "grill".
- Adjust the grid and pan position to allow for different thicknesses of food. Position the food closes the grill for faster cooking and further away for gentler cooking.

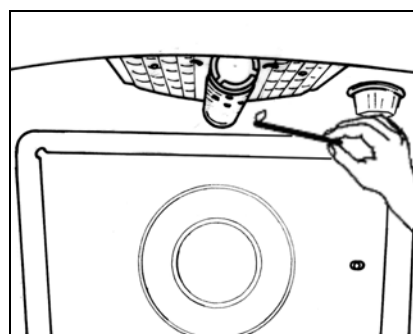
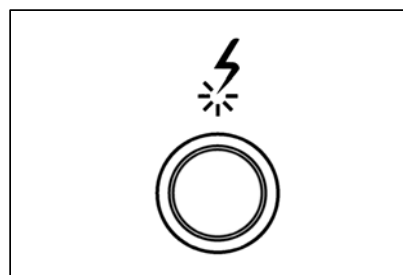
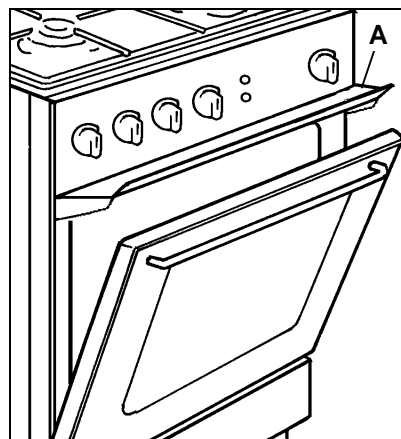

Grilling meat



When using the grill it has to be supervised, the oven door opened and the grill deflector "A" in its place.

- Prepare the meat to be grilled, lightly brush it with oil on both sides.
- Place it on the roasting grid.
- Turn the oven/grill control knob to position "grill".
- Slide the roasting grid in the guide 4 and the roasting tray in the guide 3.
- When the first side is brown, turn the meat without pricking it in order that the juices are not lost.
- Grill the second side.

Cooking time is determined by the thickness of the piece to be grilled not by its weight.

Browning

- Turn the oven/grill control knob to the "grill" position.
- Place the dish on the grid and slide it on shelf guide 4.
- Leave the dish under the grill for a few minutes.

Oven light

The oven is equipped with a lamp. It starts operating when the  switch on the control panel is pressed .

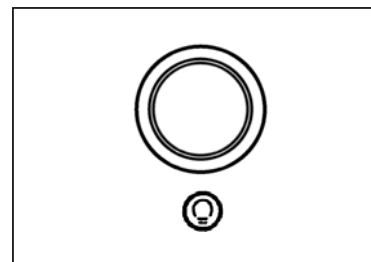
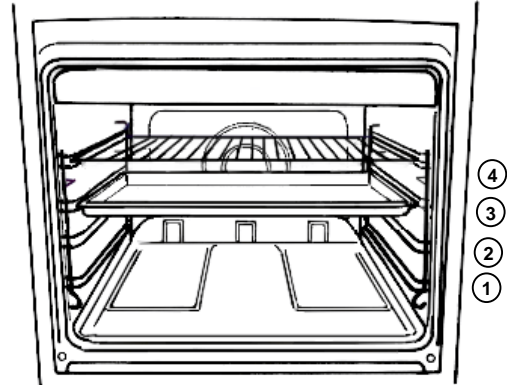

COOKING CHART

Food	Tray type or dimension (dxwxh) cm	Material of the tray	No. of tray	Shelf position	Preheating		Cooking	
					Thermo-stat pos.	Time (min)	Thermo-stat pos.	Time (min)
Roasting meal								
- beef	Roasting tray delivered with the cooker	Enamelled	1	3	5	20	5	20 min. for each 0.5 Kg / rare 25 min. for each 0.5 Kg/ medium 30min. for each 0.5 Kg/well done
- lamb			1	3	5	20	5	25 min. for each 0.5 Kg/ medium 30min. for each 0.5 Kg/well done
- pork and veal			1	3	5	20	5	30 min. for each 0.5 Kg/ medium 35min. for each 0.5 Kg/well done
Poultry								
- chicken	Roasting tray delivered with the cooker	Enamelled	1	3	5	20	5	25-30 min. for each 0.5 Kg
- turkey below 4.5 Kg			1	3	4	20	5	25 min. for each 0.5 Kg
- turkey over 4.5 Kg			1	3	4	20	5	25 min. for each 0.5 Kg
- duck			1	3	5	20	5	25 min. for each 0.5 Kg
Cakes								
- scones	33x28x0.6	Aluminum	2	2 and 4*	8	20	8	15-20
	33x28x0.6	Aluminum	1	3***	8	20	8	15-20
- fettles sponge cake	Ø 26x5	Aluminized	1	3***	4	15	4	30-40
- rich fruit cake	Ø 23x7.6	Tinned steel	1	3***	1	15	1	120-140
- small cake	33x28x0.6	Aluminum	2	2 and 4*	4	15	4	30-40
	33x28x0.6	Aluminum	1	3***	4	15	4	30-40
- Victoria sandwich	Ø 20.5x3.5	Aluminized	2	2 and 4*	5	15	5	20-30
	Ø 20.5x3.5	Aluminized	1	3***	5	15	5	20-25
- apple pie	Ø 20x5	Aluminized	2	3**	5 - 6	15	5 - 6	70-90
	Ø 20x5	Aluminized	1	3***	5	15	5	70-90
Yeast mixture								
- bread 1.35 Kg	19.5x9.3x5.5	Tinned steel	3	3	7	20	7	35-45
- bread 0.45 Kg	19.5x9.3x5.5	Tinned steel	1	1***	7	20	7	30-40

NOTE: d = deepness; w = width; h = height

Remarks: The recommended cooking conditions give the best results.

* if you should cooking more than one tray, you can take the top tray out of the oven when the cakes are finished and move the lower tray to the higher shelf to finish the cooking (about 5 min.)

** these two pans are positioned on the same shelf, at the diagonal of the oven grid



*** put the dishes in the center of the shelf

The dishes indicated for cakes and yeast mixture you can find in the shops.

Using the Hob

The Hob Burners

The symbol on the control panel shows which burner is operated by the knob. (See control panel).

- Off
-  Maximum level
-  Minimum level

Use the maximum level for boiling and the minimum for simmering.

Always choose positions between the minimum and maximum, never between maximum and off.

Ignition of the burners

- Push the knob and turn it left to the “large flame” symbol.
- At the same time, push the electronic ignition knob (see fig). Keep it pushed until the gas ignites (1 spark / second).
- Release the knob and check that the burner has ignited.
- Upon ignition, adjust the flame as required.

OR

Power Cut

- Push the corresponding knob in completely and turn it left to the “large flame” symbol and ignite with a match.
- Release the knob and check that the burner has ignited.
- Upon ignition, adjust the flame as required.

If for any reason the flame should extinguish turn off the relevant control knob, leave for at least one minute and then re-ignite.

If after a few attempts the burner does not ignite, check that the burner ring and its cap are correctly positioned.

Turning off the burners

Turn the control knob clockwise to mark « ● ».

 **Do not put anything on the hob that is liable to melt.**

Selecting the Correct burner

Above every knob there is a symbol for the corresponding burner.

For good cooking results, always choose pans, which correctly fit to the diameter of the burner used (see figs). **Choose thick, flat bottom pots.**

We recommend the flame is lowered as soon as the liquid starts boiling.

For a correct ignition always keep the burner ring and the spark plugs clean.

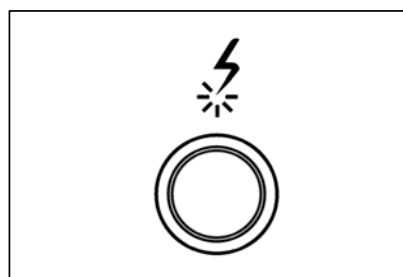
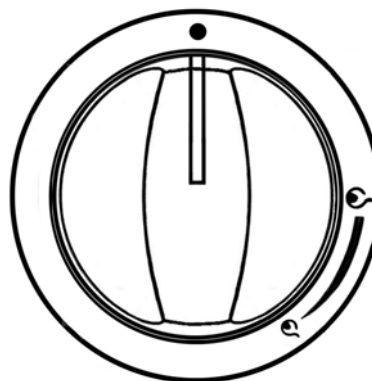

Good use



Bad use
(Power waste)



The following diameter pans can be used:

Burner	Power (kW)	Diameter (mm)	
		min.	max.
Rapid	3,00	160	280
Semi-Rapid	2,00	140	240
Auxiliary	1,00	120	180

Accessories delivered with the appliance

The following accessories are supplied with your appliance.

- Grill Deflector
To be used when the grill is operation.
- Shelf for placing dishes on (roast, pastry mounds)
The dish should be put in the middle of the shelf to balance the weight.
- A roasting tray with roasting grid on it.
It is used to collect juice when cooking in it, place it on the shelf 2.
If you do not use the roasting tray, remove it from the oven.
- Removable handles

In addition to the accessories supplied we recommend you only use heatproof dishes/pans (according to the manufacturer's instructions).

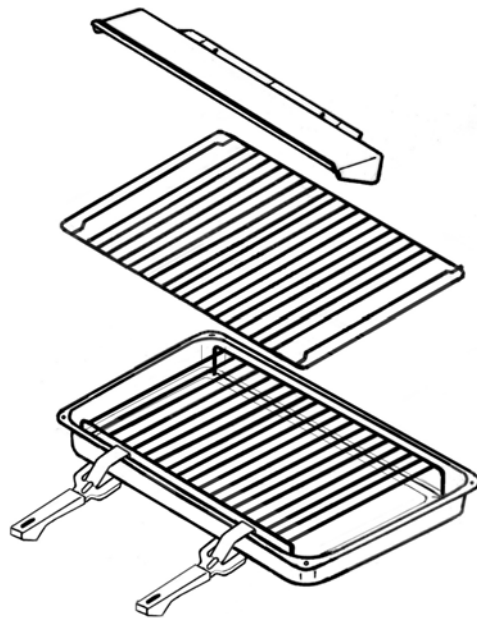

Removable drawer

The removable drawer is located underneath the oven cavity.



During cooking the drawer may become hot if the oven is in use for a long period of time. Flammable materials such as oven gloves, tea towels, plastic aprons etc. should not be stored in the drawer.

Oven accessories such as baking sheets, will also become hot, therefore care should be taken when removing these items from the drawer whilst the oven is in use or still hot.

To open

- Grasp the drawer from underneath and pull it out as shown.
- To remove the drawer, pull it out to the stop, then lift it up slowly and pull it out completely.

To replace the drawer follow the same procedure in reverse.

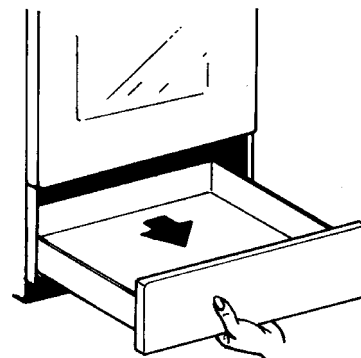

Hints and Tips

Condensation and steam

When food is heated it produces steam in the same way as a boiling kettle. The oven vents allow some of this steam to escape. However, **always stand back from the oven when opening the oven door** to allow any build up of steam or heat to release.

If the steam comes into contact with a cool surface on the outside of the oven, e.g. a trim, it will condense and produce water droplets. This is quite normal and is not a fault with the oven. To prevent discolouration, regularly wipe away condensation and also soilage from surfaces.

Cookware

Use any ovenproof cookware, which will withstand temperatures of 250°C.

Oven dishes, etc. should not be placed directly on the oven base.

Oven Cooking

- Turn off the oven 5 minutes before the end of cooking time, and use residual heat to complete the cooking.



- The thickness, the material and the colour of the pan will influence the cooking results.
- When cooking, certain dishes increase in volume, ensure the pan is large enough.
- To prevent fat dripping when roasting use tall rim pans proportional to the item being roasted.
- Prick the skin of poultry and sausages with a fork before cooking to avoid spitting.
- Use heatproof glass dishes for soufflés.

The effects of dishes on cooking results

Dishes and tins vary in their thickness, conductivity, colour, etc. which affects the way they transmit heat to the food inside them.

- A** Aluminium, earthenware, oven glassware and bright shiny utensils reduce cooking and base browning.
- B** Enamelled cast iron, anodised aluminium, aluminium with non-stick interior and coloured exterior and dark, heavy utensils increase cooking and base browning.

MAINTENANCE AND CLEANING

-  ***The oven should be kept clean at all times. A build-up of fats or other foodstuffs could result in a fire.***
-  ***Before cleaning, ensure all control knobs are in the OFF position, and the appliance has cooled completely.***
-  ***Before any maintenance or cleaning can be carried out, you must DISCONNECT the cooker from the electricity supply.***

Cleaning materials

Before using any cleaning materials on your oven, check that they are suitable and that their use is recommended by the manufacturer.

-  ***Cleaners that contain bleach should NOT be used as they may dull the surface finishes. A steam cleaner is not to be used. Harsh abrasives should also be avoided.***

External cleaning

We recommend for cleaning cleaners that do not scratch the surface; Avoid use of metal objects, steel wool or nylon pads, abrasive or caustic products, or diluents. Regularly wipe over the control panel, the cover, oven door and door seal using a soft cloth well wrung out in warm water to which a little washing up liquid has been added.

-  ***To prevent damaging or weakening the door glass panels avoid the use of the following:***
 - ***Household detergent and bleaches***
 - ***Impregnated pads unsuitable for non stick saucepans***
 - ***Brillo/Ajax pads or steel wool pads***
 - ***Chemical oven pads or aerosols***
 - ***Rust removers***
 - ***Bath/Sink stain removers***

Oven Cavity

The enamelled oven cavity is best cleaned whilst the oven is still warm.

Wipe the oven over with a soft cloth soaked in warm soapy water after each use. From time to time it will be necessary to do a more thorough cleaning, using a proprietary oven cleaner.

Hob

After every use wipe with a soft cloth well wrung out in warm water to which a little washing up liquid has been added, avoiding any leakage through the holes of the hob. Rinse and dry with a soft cloth.

To remove more stubborn stains, wet and leave to dissolve, do not scratch and avoid the use of abrasive or caustic products that could damage the enamel.

Burners

The burner caps and crowns can be removed for cleaning. Wash the burners caps and crowns using hot soapy water, and remove marks with a mild paste cleaner. A well-moistened soap impregnated steel wool pad can be used with caution, if the marks are particularly difficult to remove.

After cleaning, be sure to wipe dry with a soft cloth.

! *DO NOT clean the oven door while the glass panels are warm. If this precaution is not observed the glass panel may shatter. If the door glass panel becomes chipped or has deep scratches, the glass will be weakened and must be replaced to prevent the possibility of the panel shattering. Contact your local Service Centre who will be pleased to advise further.*

OVEN BULB REPLACEMENT

! Ensure that the appliance is switched off and disconnected from the electricity supply before replacing the bulb to avoid possibility of an electric shock.

If the oven bulb needs replacing, it must comply with the following specifications:

Wattage:	25W
Voltage:	230/240V(50Hz)
Temperatures:	300°C
Thread Type:	E14

☞ To replace the faulty bulb.

1. Turn the glass cover anticlockwise and remove.
2. Remove the faulty bulb by turning it anticlockwise and replace with a new one.
3. Refit the glass cover.

Reconnect the appliance to the electricity supply.

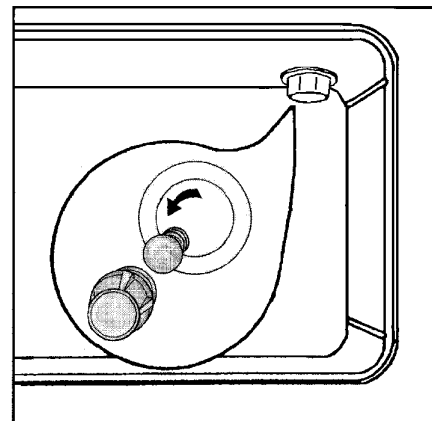

SOMETHING NOT WORKING

If the appliance is not working correctly, please carry out the following checks, before contacting your local Service Force Centre.

IMPORTANT: If you call out an engineer to a fault listed below, or to repair a fault caused by incorrect use or installation, a charge will be made even if the appliance is under guarantee.

Symptoms	Solutions
1. No burner ignition	Check that: <ul style="list-style-type: none"> • Gas supply is completely open • The position of gas pipe is correct • The burner is not wet • The burner cap and ring burner have been replaced correctly after cleaning
2. The gas ring burns unevenly	Check that: <ul style="list-style-type: none"> • The main jet is not blocked and the ring burner is clean of food particles • The burner cap and ring burner have been replaced correctly after cleaning
3. One of the oven or grill burners does not ignite	Check that: <ul style="list-style-type: none"> • The burner is in its correct place • The burner is not wet • The control knob has been pressed for 10 seconds upon ignition
4. Cooking results are not satisfactory	Check that: <ul style="list-style-type: none"> • The correct temperature has been selected • The cooking time is adapted • The grill is placed correctly in the oven
5. Cooking time is too long	Check that: <ul style="list-style-type: none"> • The temperature is correct for the type of food to be cooked.
6. The oven smokes	Check that: <ul style="list-style-type: none"> • The oven does not need cleaning • The food does not spill over • There is no excessive fat / juice on the oven sides • Check the fuses.

If after these checks, the appliance still does not operate correctly, contact your local Service Force Centre. When you contact the Service Force Centre you will need to give the following details:

1. Your name, address and post code.
2. Your telephone number
3. Clear and concise details of the fault
4. The model and serial number of the appliance (found on the rating plate*)
5. The purchase date

* The rating plate can be found on the lower left hand corner of the front frame of the cavity.

Please note that a valid purchase receipt or guarantee documentation is required for in-guarantee service calls.

SERVICE AND SPARE PARTS



In the event of your appliance requiring service, or if you wish to purchase spare parts, please contact your local Service Force Centre by telephoning: -

08705 929929

Your telephone call will be automatically routed to the Service Force Centre covering your post code area.

For the address of your local Service Force Centre and further information about Service Force, please visit the website at www.serviceforce.co.uk

In-guarantee customers should ensure that the checks under the heading “Something Not Working” have been made as the engineer will make a charge if the fault is not a mechanical or electrical breakdown. Please note that it will be necessary to provide proof of purchase for any in-guarantee service calls.

CUSTOMER CARE

For general enquiries concerning your Tricity Bendix appliance and or for further information on our products, contact our Customer Care Department by letter or telephone as follows:

Major Appliances - Customer Care Department
Tricity Bendix
Addington Way
Luton
Bedfordshire
LU4 9QQ

Tel: 08705 950950 (*)

(*) calls to this number may be recorded for training purposes.

GUARANTEE CONDITIONS

Standard Guarantee Conditions

We Tricity Bendix undertake that if, within 12 months of the date of the purchase, this Tricity Bendix appliance or any part thereof is proved to be defective by any reason only of faulty workmanship or materials, we will, at our option, repair or replace the same FREE OF ANY CHARGE for labour, materials or carriage on condition that:

- The appliance has been correctly installed and used only on the electricity supply stated on the rating plate.
- The appliance has been used for normal domestic purposes only, and in accordance with the manufacturer's instructions.
- The appliance has not been serviced maintained, repaired, taken apart or tampered with by any person not authorised by us.
- All service work under this guarantee must be undertaken by a Tricity Bendix Service Force Centre.
- Any appliance or defective part replaced shall become the Company's property.
- This guarantee is in addition to your statutory and other legal rights.

Home visits are made between **8.30am and 5.30pm** Monday to Friday. Visits may be available outside these hours, in which case a **premium** will be charged.

Exclusions

This guarantee does not cover:

- Damage or calls resulting from transportation, improper use or neglect, the replacement of any light bulbs or removable parts of glass or plastic.
- Costs incurred for calls to put right an appliance, which is improperly installed, or calls to appliance outside the United Kingdom.
- Appliances found to be in use within a commercial or similar environment, plus those, which are the subject to rental agreements.

Products of Tricity Bendix manufacture which are not marketed by Tricity Bendix.

European Guarantee

If you should move to another country within Europe then your guarantee moves with you to your new home subject to the following qualifications:

- The guarantee starts from the date you first purchased your product.
- The guarantee is for the same period and to the same extent for labour and parts as exist in the new country of use for this brand or range of products.
- This guarantee relates to you and cannot be transferred to another user.
- Your new home is within the European Community (EC) or European Free Trade Area.
- The product is installed and used in accordance with our instructions and is only used domestically, i.e. a normal household
- The electrical supply complies with the specification given in the rating label.
- The product is installed taking into account regulations in your new country.

Before you move, please contact your nearest Customer Care Centre, listed below, to give them details of your new home. They will then ensure that the local Service Organisation is aware of your move and able to look after you and your appliances.

France	Senlis	+33 (0) 3 44 62 20 13
Germany	Nürnberg	+49 (0) 800 234 7378
Italy	Pordenone	+39 (0) 800117511
Sweden	Stockholm	+46 (0) 20 78 77 50
UK	Luton	+44 (0) 8705 950950

INSTRUCTIONS FOR THE INSTALLER

TECHNICAL FEATURES

Free standing

Class 1

Hob	Lid Pan support Front right burner Back right burner Front left burner Back left burner Hob ignition	Painted Enamelled Semirapid Semirapid Rapid Auxiliary	2000 W 2000 W 3000 W 1000 W Spark
Oven	Oven Oven burner power Grill Grill burner power Oven lamp Oven ignition Cleaning	Gas 3000 W Gas 2000 W Lamp 25W type E14 Spark Manual	
Cavity dimensions	Height Width Depth Oven volume	267 mm 405 mm 381 mm 41,2 l	
Accessories	Oven shelf Roasting tray + 2 handles Roasting grid Grill deflector		
Dimensions	Height Width Depth	900 mm 500 mm 600 mm	

 This appliance complies with the following EEC Directives :
93/68 ; 73/23 (Low Voltage Directive) and subsequent modifications,
89/336, 90/31, 93/68 (Electro- magnetical Compatibility Directive) and subsequent modifications,
90/396 (Gas Appliance Directive) **93/68** (General Directives) and subsequent modifications.

ADVICE FOR SAFETY

Gas connections

- Before installation ensure that the local distribution conditions (gas type and pressure) and the pre-setting of the appliance are consistent.
- This appliance must be installed only in a room with good ventilation.
- This appliance must not be connected to a chimney. It has to be installed and connected in accordance with the rules in force. Special attention should be paid to the applicable disposal concerning ventilation.
- The adjacent furniture panels have to be heat proof or protected by such material.
- The adjusting conditions of this appliance are mentioned on the rating plate.

Connection to gas supply.

Check that the gas flow and the diameter of the supply pipe is sufficient to supply all the appliances of the installation.

- Check that all connections are tight.
- Install an accessible and visible gas tap to isolate the appliance.



The manufacturer declines any responsibility for possible damages resulting from an installation, which doesn't comply with current legislation.

- **Installation of flues and ventilation for gas appliances of rated input not exceeding 60 kW (1st, 2nd and 3rd family gases) – Part 2 Specification for installation of ventilation for gas appliances – BS 5440 Current editions;**
- **Gas burning appliances – Part 3 Domestic cooking appliances burning gas – BS 5386 Current editions;**
- **Specification for installation of low pressure gas pipe work of up to 20mm (R1) in domestic premises (2nd family gas) – BS 6891 Current editions;**
- **Pipe threads for tubes and fittings where pressure-tight joints are made on the threads (metric dimensions) – BS 21 Current editions;**
- **Flexible hoses, end fittings and sockets for gas burning appliances – BS 669 Current editions;**
- **Installation of domestic gas cooking appliances (1st, 2nd and 3rd family gases) – BS 6172: 1990 Current editions;**

Electrical connections

! Any electrical work required to install this cooker should be carried out by a qualified electrician or competent person, in accordance with the current regulations.

! **THIS COOKER MUST BE EARTHED.**

! The manufacturer declines any liability should these safety measures not be observed.

This cooker is designed to be connected to a 230-240V AC 50Hz electrical supply.

Before switching on, make sure the electricity supply voltage is the same as that indicated on the cooker rating plate. The rating plate is located on the oven frame.

The cooker is supplied with a 3-core flexible supply cord incorporating a 13amp plug fitted. In the event of having to change the fuse, a 13amp ASTA approved (BS 1362) fuse must be used. Should the plug need to be replaced for any reason, the wires in the mains lead are coloured in accordance with the following code:

Green and Yellow	- Earth
Blue	- Neutral
Brown	- Live

- Connect the green and yellow (earth) wire to the terminal in the plug, which is marked with the letter 'E' or the earth symbol  or coloured green and yellow.
- Connect the blue (neutral) wire to the terminal in the plug, which is marked with the letter 'N' or coloured black.
- Connect the brown (live) wire to the terminal in the plug, which is marked with the letter 'L' or coloured red.

NOTE: The earth wire should be about 2 cm longer than the live and neutral wires.

Upon completion there must be no cut, or stray strands of wire present and the cord clamp must be secure over the outer sheath.

! A cut off plug inserted into a 13-amp socket is a serious safety (shock) hazard. Ensure that the cut off plug is disposed of safely.

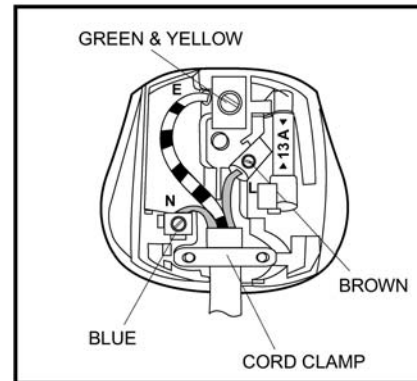

Before connecting check that:

- The plug used for connection is easily accessible when the appliance is installed.

Permanent Connection

In the case of a permanent connection, it is necessary that you install a double pole switch between the cooker and the electricity supply (mains), with a minimum gap of 3mm, between the switch contacts and of a type suitable for the required load in compliance with the current electric regulations.

The switch must not break the yellow and green earth cable at any point.

! Ensure that the cooker supply cord does not come into contact with surfaces with temperatures higher than 50 deg. C.

INSTALLATION

Location of appliance

The appliance must not be installed in a bed-sitting room of volume less than 20m^3 or in a bathroom or shower room. It is essential that the appliance is positioned as in the enclosed figure i.e. shelves, wall cabinets and cooker hoods must be fitted a minimum of 690mm directly above the hob and 400mm above the hob when fitted in line with the outside of the appliance. If the units are intended to be fitted adjacent to the appliance but less than 400mm above the hob, then a minimum space of 100mm must be maintained between the sides of the unit and the appliance (see fig).

If fitted next to or between two base units a minimum space of 1mm must be left between each unit and the sides of the appliance. The levelling feet fitted to the appliance will achieve a nominal height to hob of $900\text{mm}+10\text{mm}$.

The appliance must be installed in accordance with EN 1116-1995, regarding the depth of the superior furniture.

⚠ The appliance must be set on a heatproof floor. The adjustable feet must not be removed.

⚠ L.P.G. cookers or ovens MUST NOT be installed below ground level, i.e. in a basement, or aboard any boat, yacht or other vessel.

⚠ The cooking appliance must be fitted with a stability chain firmly secured to the wall (see fig).

Ventilation

The room containing the cooker should have an air supply in accordance with B.S. 5440: Part 2: Current Editions.

The following requirements for ventilation must be met.

The cooker should not be installed in a bed sitting room with a volume of less than 20m^3 , if it is installed in a room of volume less than 5m^3 an air vent of effective area of 110cm^2 is required; if it is installed in a room of volume between 5m^3 and 10m^3 , an air vent of effective area 50cm^2 is required, while if the volume exceeds 11m^3 no air vent is required. However, if the room has a door, which opens directly to the outside, no air vent is required even when the volume is between 5m^3 and 11m^3 .

If there are other fuels burning appliances in the same room, B.S. 5440: Part. 2: Current Editions should be consulted to determine the requisite air vent requirements.

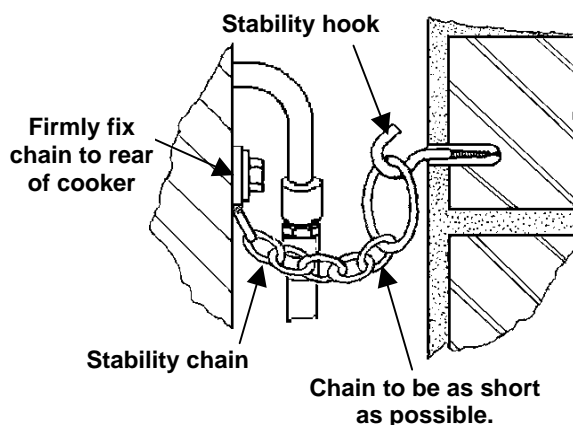
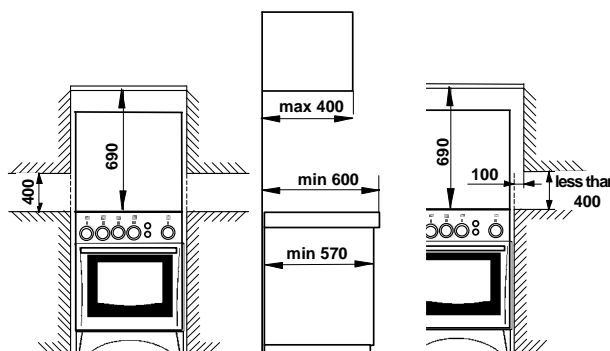

Levelling

The appliance is provided with adjustable small feet placed in the back and front corners of the base.

By adjusting the small feet it is possible to change the height of the appliance so as to ensure a better levelling with other surfaces and a uniform distribution of the liquids contained in pans or pots.

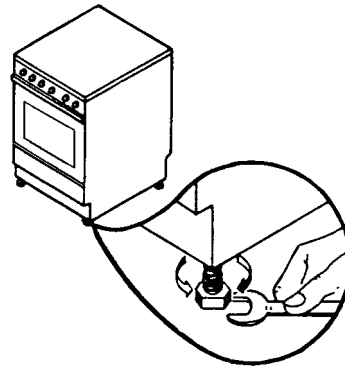

GAS CONNECTIONS

Gas connection must be carried out according to the rules in force.

Your cooker is delivered adjusted for the kind of gas stated on the rating plate.

If the appliance is converted to natural gas and the pressure for natural gas is 20mbar. The following methods of connection to the gas supply must be used:

Left Hand Connection (from front)

Ensure that the rubber hose and power cord are not in contact with any part of the hatched area shown in the diagram and that the loop of the hose when connected is not in contact with the floor when the appliance is in position.

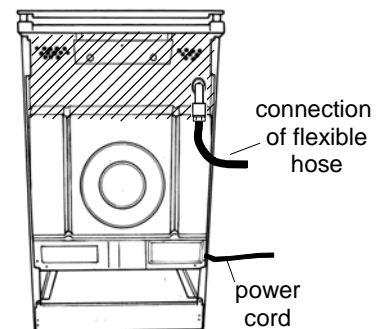

Right Hand Connection (from front)

Ensure that the rubber hose and power cord are not in contact with any part of the hatched area shown in the diagram. It will be necessary to fit the maximum length hose when using this method.

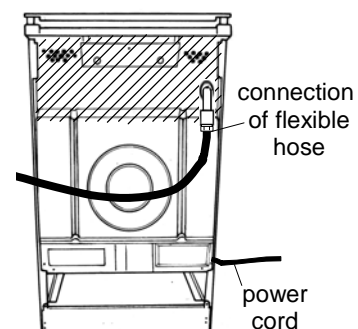

Rigid Connection

Where it is not possible to make the connection using a rubber hose, a rigid pipe work connection must be used.

Recommendations when using an appliance flexible connector are as follows:

- For NATURAL the gas installation pipes to the termination point shall comply with:

Specification for installation of low-pressure gas pipe work of up to 20mm (R1) in domestic premises (2nd family gas) – BS 6891;

Connection shall be by means of an appliance flexible connector for use with a self-sealing plug-in device, complying with:

Flexible hoses, end fittings and sockets for gas burning appliances – BS 669;

LPG flexible connections must be of a *type* suitable for LPG and capable of operation up to 50mbar and to carry a red strips, band or label.

- The appliance flexible connector should not be subjected to undue forces either in normal use or whilst connected or disconnected; The socket which the plug of the appliance flexible connector fits should be permanently attached to a firmly fixed gas installation pipe and positioned such that the appliance flexible connector hose hangs freely downwards (see fig.);
- The appliance flexible connector should be positioned such that it will not suffer mechanical damage, e.g. abrasion from the surrounding kitchen furniture, which may be moved in use such as a drawer or door, or by being trapped by any stability device.

The plug-in-connector bayonet should be accessible for disconnection after moving the appliance.

Levelling

The appliance is provided with adjustable small feet placed in the back and front corners of the base.

By adjusting the small feet it is possible to change the height of the appliance so as to ensure a better levelling with other surfaces and a uniform distribution of the liquids contained in pans or pots.

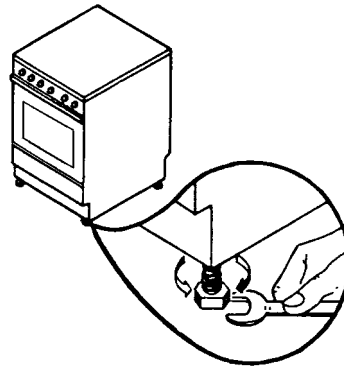

GAS CONNECTIONS

Gas connection must be carried out according to the rules in force.

Your cooker is delivered adjusted for the kind of gas stated on the rating plate.

If the appliance is converted to natural gas and the pressure for natural gas is 20mbar. The following methods of connection to the gas supply must be used:

Left Hand Connection (from front)

Ensure that the rubber hose and power cord are not in contact with any part of the hatched area shown in the diagram and that the loop of the hose when connected is not in contact with the floor when the appliance is in position.

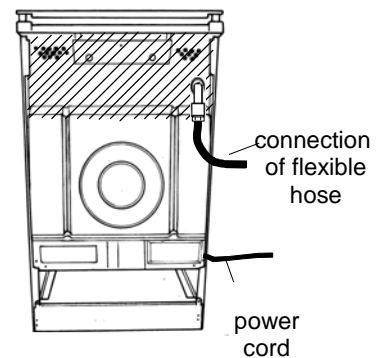

Right Hand Connection (from front)

Ensure that the rubber hose and power cord are not in contact with any part of the hatched area shown in the diagram. It will be necessary to fit the maximum length hose when using this method.

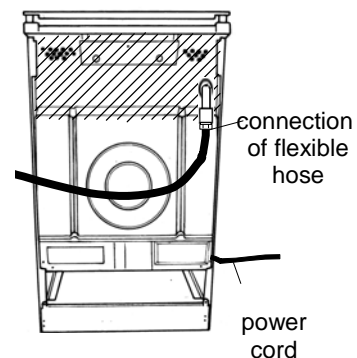

Rigid Connection

Where it is not possible to make the connection using a rubber hose, a rigid pipe work connection must be used.

Recommendations when using an appliance flexible connector are as follows:

- For NATURAL the gas installation pipes to the termination point shall comply with:

Specification for installation of low-pressure gas pipe work of up to 20mm (R1) in domestic premises (2nd family gas) – BS 6891;

Connection shall be by means of an appliance flexible connector for use with a self-sealing plug-in device, complying with:

Flexible hoses, end fittings and sockets for gas burning appliances – BS 669;

Replace the nozzles of the hob burners

 Before any modifications or conversion to a kind of different gas, you must **DISCONNECT** the cooker from the electricity supply and ensure that all control knobs are in the **OFF** position, and the appliance has cooled completely.

Hob burners

- Remove the pan supports;
- Remove the caps and the burner crowns;
- Using a No 7 socket spanner unscrew the nozzles and replace them with those required for the type of gas in use (see table no. 1).

Reassemble the parts following the same procedure in reverse.

These burners do not need any primary air regulation.

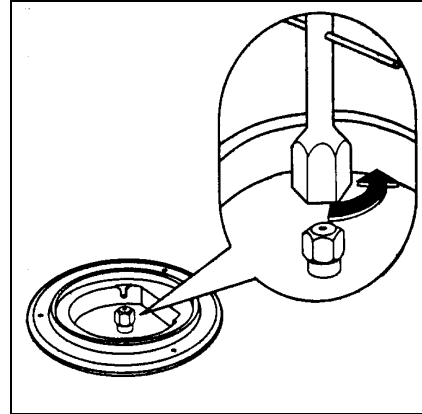

Adjustment of minimum level for the hob burners

The burner is correctly adjusted when the flame is stable silent and goes out without any noise.

When changing the type of gas check that the minimum level is correct. The air admission is correct when the flame is about 4 mm in length.

The top burners do not need adjustment of primary air.

Check that, turning the knob quickly from the maximum position to the minimum one, the flame does not go out.



no air



correct
adjustment



excess of
air

Hob burners

To adjust the minimum level:

- Light the burner
- Turn the knob to the position of the minimum flame;
- Remove the knob;
- Unscrew or screw the by-pass screw (on the right above of tap shaft) until a regular small flame is reached.
- For LPG screw completely the by-pass screw.

Reassemble the parts following the same procedure in reverse.

Check that, when turning the knob quickly from the maximum position to the minimum one, the flame does not go out.

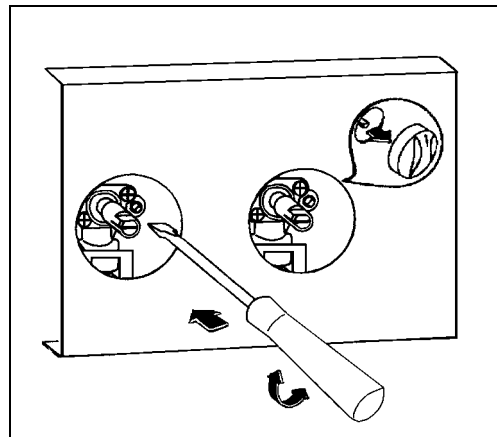

Replace the nozzles of the oven burners

Oven burner

To replace the gas oven nozzle, follow this procedure:

- Check the table no.1 for diameter of nozzle;
- Remove the oven removable base panel;
- Remove the screw 1 on the oven burner
- Remove the oven burner by pulling it forwards.
- Replace the nozzle by means of a No 7 socket spanner;

Reassemble the parts following the same procedure in reverse.

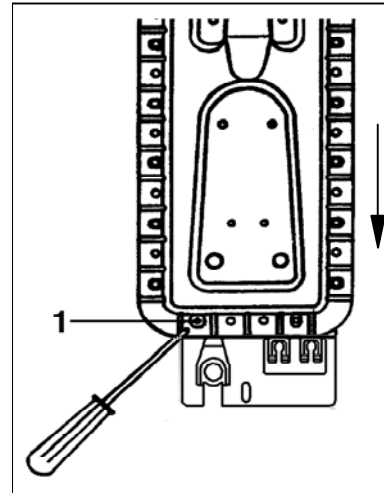

Grill burner

To replace the gas grill nozzle, follow this procedure:

- Remove the grill burner after removing the fixing screws.
- Replace the nozzle by means of a No 7 socket spanner;
- Refit all parts and test.

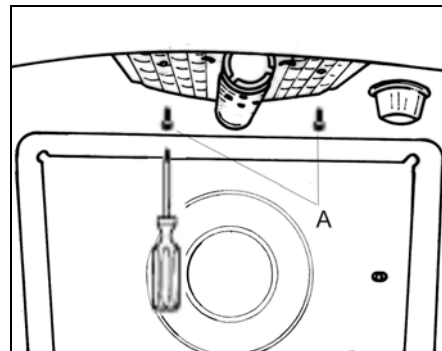

Adjustment of minimum level

Oven burner

- Light the burner knob on position maximum and leave the oven door closed for about 10 min.
- Turn the knob slowly to position minimum.
- Pull off the knob to adjust minimum flow.
- Unscrew or screw the by-pass screw (is it above of tap shaft) until a regular small flame is reached.
- For LPG screw completely the by-pass screw.

The flame shouldn't extinguish when closing the oven door.

Grill burner

The grill temperature cannot be adjusted. To obtain a lower temperature or slower cooking time the grill pan must be lowered away from the flame.



After completion of any repairs, conversion or adjustments, the statutory safety tests must be carried out.

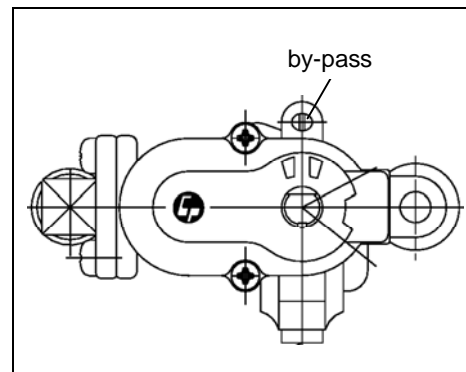



The symbol  on the product or on its packaging indicates that this product may not be treated as household waste. Instead it shall be handed over to the applicable collection point for the recycling of electrical and electronic equipment. By ensuring this product is disposed of correctly, you will help prevent potential negative consequences for the environment and human health, which could otherwise be caused by inappropriate waste handling of this product. For more detailed information about recycling of this product, please contact your local city office, your household waste disposal service or the shop where you purchased the product.

TRICITY BENDIX

Customer Care Department
Major Appliances
Addington Way
Luton
Bedfordshire
LU4 9QQ

SIG233/1W-SIG233/1B – 342701435-B-16012007-02

© Electrolux plc 2005



From the Electrolux Group. *The world's No.1 choice*

The Electrolux Group is the world's largest producer of powered appliances for kitchen, cleaning and outdoor use. More than 55 million Electrolux Group products (such as refrigerators, washing machines, vacuum cleaners, chain saws and lawn mowers) are sold each year to a value of approx. USD 14 billion in more than 150 countries around the world.

Free Manuals Download Website

<http://myh66.com>

<http://usermanuals.us>

<http://www.somanuals.com>

<http://www.4manuals.cc>

<http://www.manual-lib.com>

<http://www.404manual.com>

<http://www.luxmanual.com>

<http://aubethermostatmanual.com>

Golf course search by state

<http://golfingnear.com>

Email search by domain

<http://emailbydomain.com>

Auto manuals search

<http://auto.somanuals.com>

TV manuals search

<http://tv.somanuals.com>