



Assembly Manual

Tractors

Models

Garden Tractors

13039 —16HP Hydro Drive

13040 —18HP Hydro Drive

13053 —15HP Gear Drive

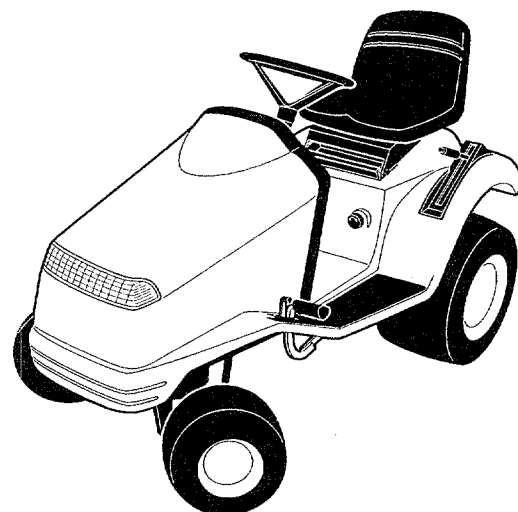

Assembly

ASSEMBLY CHECKLIST

Inspect crate

Inspect crate for evidence of product damage. If any suspect damage exists, contact the carrier (trucking company) immediately.

Tools

- Crowbar (for unpacking).
- Hammer.
- 3/4" socket wrench.
- 9/16" socket wrench.
- 9/16" open-end wrench.
- 7/16" socket wrench.
- 7/16" open-end wrench.
- Retaining ring pliers (expandable).
- Hoist or floor jack.
- Tire pressure gauge.
- 1/4" drift pin.
- Flashlight.

Remove from crate

Using crowbar, remove crating from around unit. Remove ties securing wheels to crate. Remove material securing front wheel spindles to crate.

With a 9/16" wrench, remove hardware securing back of unit to crate.

Unpack complete unit. Inspect all parts. Inspect contents of hardware pack against following list.

Product content

- Tractor.
- 2 Front wheels.
- 2 Rear wheels.
- Steering wheel (includes roll pin).
- Seat assembly.
- Hardware Bag (includes):
 - B.....Special Washer, 1 x 2-1/2.....2
 - C.....Special Washer, 1 x 1-1/2.....4
 - D.....Retaining Ring.....2
 - E.....Hub Cap.....4
 - M.....Lug Nut, 7/16-20.....10
 - U.....Screw, 3/8-16 x 7/8.....2
 - X.....Nut, 3/8-16.....2
- Ignition Key (spare).....1
- Hitch Pins (for attachments).....2
- Oil Drain Hose (See Section 6)....1

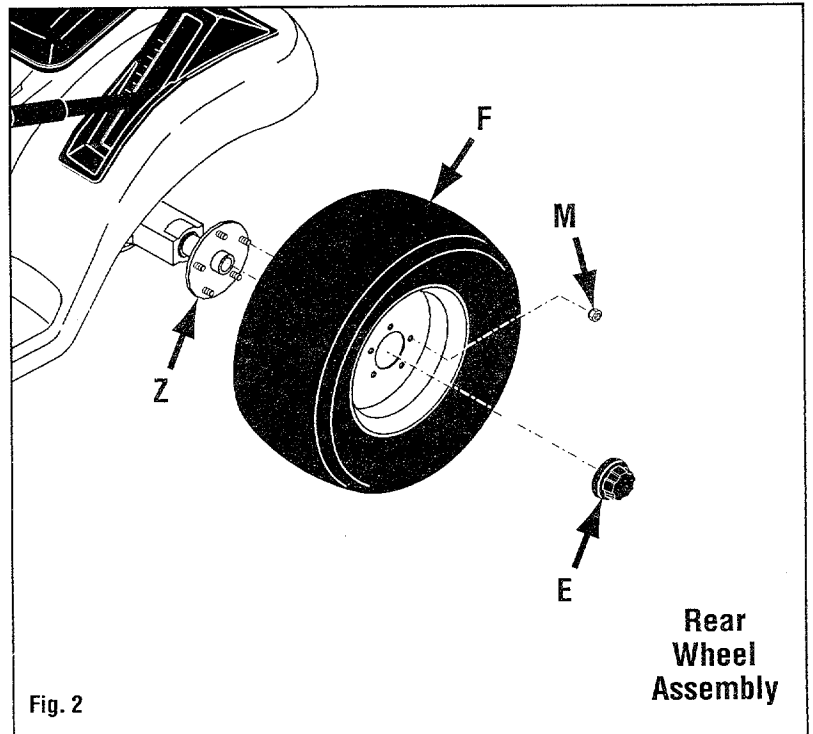
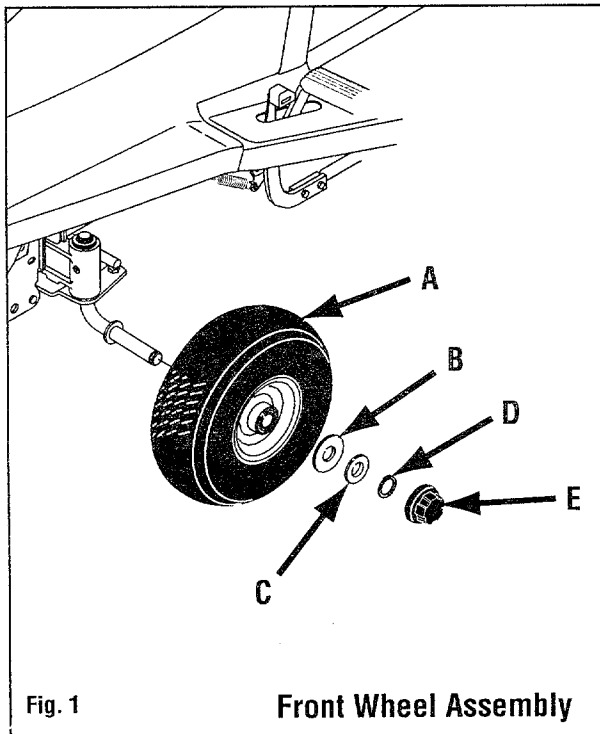

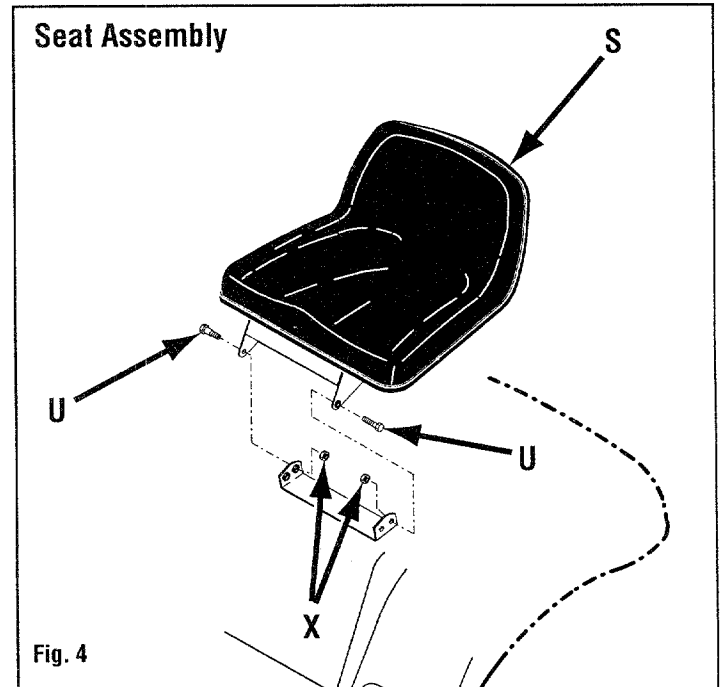
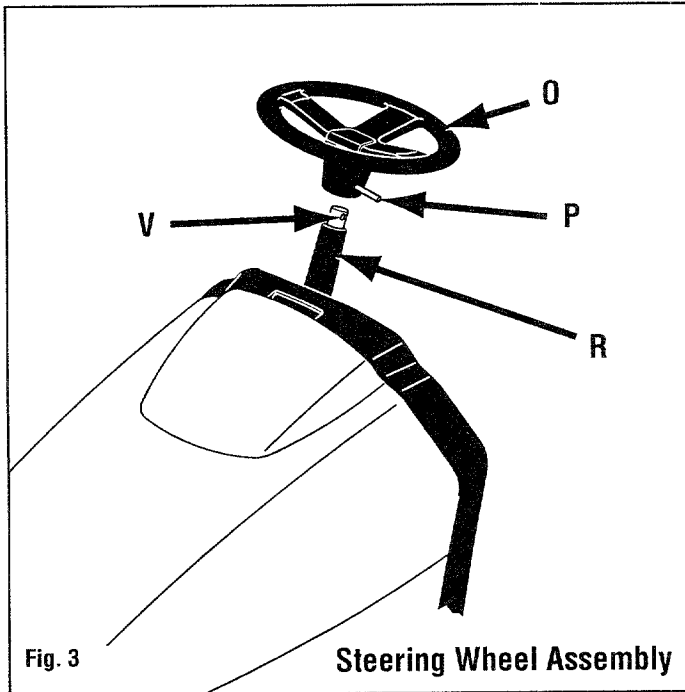

Rear Wheels

☐ Hoist or jack rear of unit at rear hitch high enough to allow rear wheels to slide onto wheel hubs (Z, Fig. 2).

WARNING

USE EXTREME CARE WHEN JACKING OR HOISTING TRACTOR. BLOCK WHEELS AND USE JACKSTANDS TO SECURELY HOLD UNIT IN PLACE.

- ☐ Grease studs on rear wheel hubs with multi-purpose grease.
- ☐ Position wheels (F) with valve stems to the inside on studs in hub (Z).
- ☐ Secure wheels to hubs with lug nuts (M) with 3/4" socket wrench. Torque to 45 ft-lbs. Position lug nuts on studs with tapered ends to the inside.
- ☐ Install hub caps (E).

Front Wheels

- ☐ Securely block rear wheels to prevent tractor from rolling.
- ☐ Hoist or jack front of unit high enough to allow front wheels to slide onto wheel spindles. If a jack is used, jack at center point of front axle.
- ☐ Slide wheels (A, Fig. 1) with valve stems to the inside and washers (B and C)

onto wheel spindles. **Note: Use washers (C) as required to take up slack.**

- ☐ Using retaining ring pliers, secure wheels with retaining rings (D).
- ☐ Install hub caps (E).

Tire Pressure

- ☐ Use air pressure gauge to check tire pressure. Adjust as necessary.
FRONT TIRES: 12-14 PSI (82-96 kPa)
REAR TIRES: 8-10 PSI (55-69 kPa)

Steering Wheel

- ☐ Align front wheels of unit so they point straight ahead.
- ☐ Place steering wheel (O, Fig. 3) with roll pin (P) over steering column (R). Rotate steering wheel as shown.
- ☐ Align steering wheel on steering shaft (V) as follows: place drift pin in hole opposite roll pin in steering wheel. Rotate steering wheel until drift pin slides into mating hole in steering shaft.
- ☐ Secure steering wheel by tapping roll pin (P) with hammer until it is completely inside steering wheel.

Seat

- ☐ Place seat assembly (S, Fig. 4) onto seat bracket.
- ☐ Using a 9/16" socket and a 9/16" open-end wrench, secure seat with screws (U)

Interlock Switch Connection (under seat)

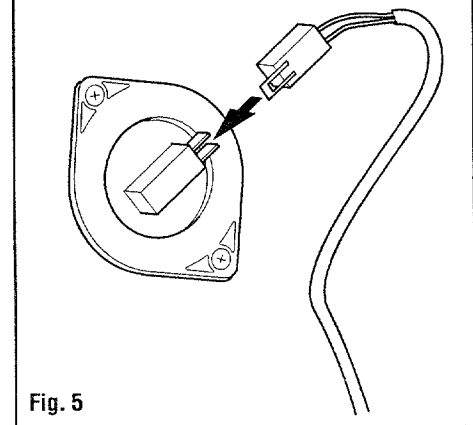

and nuts (X) at desired hole in seat bracket. **Note: Operators with inseam lengths 30" (or shorter) to 38" should use front hole in seat bracket; operators with inseam lengths 38" and over should use rear hole in seat bracket.**

- ☐ Plug seat interlock lead (Fig. 5) into interlock switch on bottom of seat.

Assembly (continued)

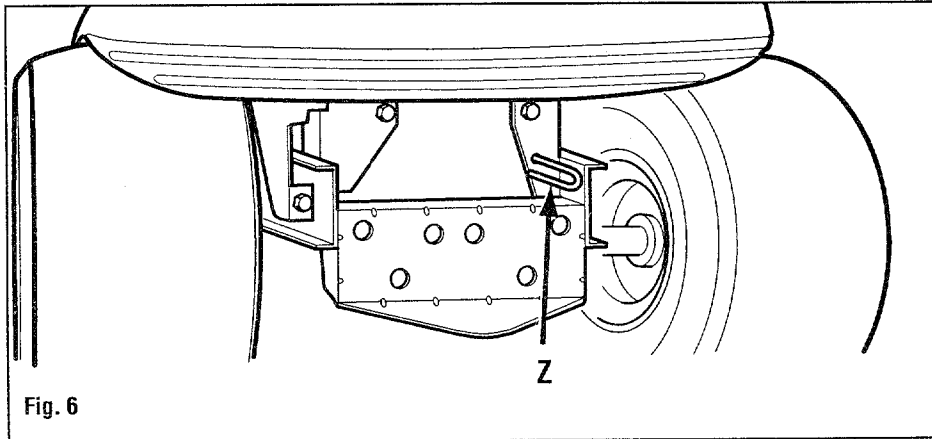

Fig. 6

Roll Unit Off Crate

- Check crate for, and remove, any nails/sharp objects which could puncture tires.
- Place transmission into neutral as follows:

Hydrostatic Drive Units: Pull hydrostatic freewheeling actuator (Z, Fig. 6) out and rotate to place in the locked position. **Note: After pushing unit, be sure to return the freewheeling actuator back to the normal position. Transmission will not drive unit when freewheeling actuator is engaged.**

Gear Drive Units: Place gear shift lever into neutral position.

- Roll unit off crate.

Engine

WARNING

ENGINE SHIPPED WITHOUT OIL IN THE CRANKCASE! PERMANENT ENGINE DAMAGE WILL RESULT FROM OPERATING ENGINE WITHOUT OIL, WHICH MANUFACTURER DOES NOT COVER UNDER WARRANTY.

Note: Refer to the engine manual provided with your unit for more specific engine oil information. The "Operation" and "Maintenance" sections of the Owner/Operator Manual also contain engine oil information.

CAUTION

DO NOT OVERFILL ENGINE WITH OIL.

Determine type of oil by following recommendations indicated in engine manual.

Battery

WARNING

BATTERY ELECTROLYTE CAN CAUSE SEVERE BURNS. EYE CONTACT CAN CAUSE BLINDNESS. ALWAYS WEAR EYE PROTECTION AND RUBBER GLOVES WHEN WORKING AROUND BATTERY.

IF ELECTROLYTE CONTACTS SKIN OR EYES, RINSE IMMEDIATELY WITH WATER FOR AT LEAST 15 MINUTES. CALL PHYSICIAN IMMEDIATELY. RINSE EMPTY ELECTROLYTE PACKAGE WITH LARGE QUANTITIES OF WATER. DESTROY EMPTY ELECTROLYTE PACKAGE TO HELP PREVENT ACCIDENTS.

- Activate battery as follows:
 1. Remove battery from unit.
 2. Remove battery vent plugs.
 3. Fill each cell in battery with electrolyte as shown in Fig. 7. **DO NOT OVERFILL!** Read and follow instructions provided with electrolyte for proper electrolyte package handling instructions.

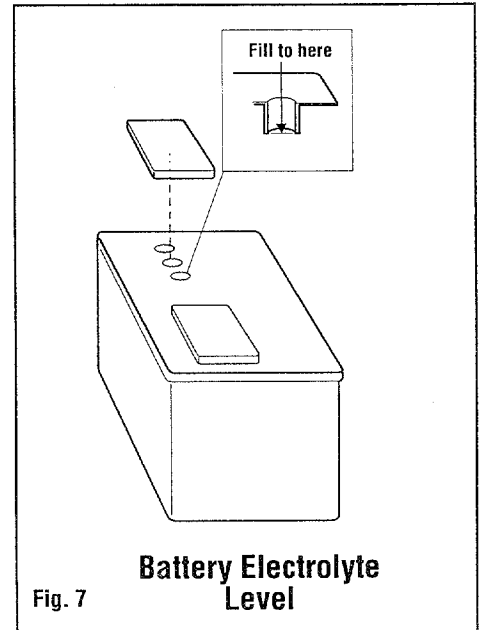

Fig. 7

Battery Electrolyte Level

4. Wait 20-30 minutes and recheck electrolyte level. Add additional electrolyte if necessary. **Note: Add only water to replace battery electrolyte loss once battery is activated.**
5. Replace battery vent plugs.
6. Charge battery at 2 amps for 2 hours.
7. Reinstall battery in unit. Connect positive (+) battery cable to positive (+) battery terminal. Connect negative (-) battery cable to negative (-) battery terminal.

WARNING

BATTERIES PRODUCE EXPLOSIVE GASSES. KEEP OPEN FLAMES AND SPARKS AWAY. DO NOT SET TOOLS ACROSS BATTERY TERMINALS.

Hydrostatic Drive Units

- Check hydrostatic drive fluid level as indicated in the "Maintenance" section of the owner/operator manual. Add fluid if necessary.

Wax Hood

- Remove protective plastic from hood.
- Apply a good grade of automotive wax to the hood. This will help preserve the color and finish.

Free Manuals Download Website

<http://myh66.com>

<http://usermanuals.us>

<http://www.somanuals.com>

<http://www.4manuals.cc>

<http://www.manual-lib.com>

<http://www.404manual.com>

<http://www.luxmanual.com>

<http://aubethermostatmanual.com>

Golf course search by state

<http://golfingnear.com>

Email search by domain

<http://emailbydomain.com>

Auto manuals search

<http://auto.somanuals.com>

TV manuals search

<http://tv.somanuals.com>