



Owner/Operator Manual

GTX Garden Tractor

- Safety
- Operation
- Maintenance

Models

13074 – GTX 18 (18 HP)

13076 – GTX 20 (20 HP)

13101 – GTX 16 (16 HP)

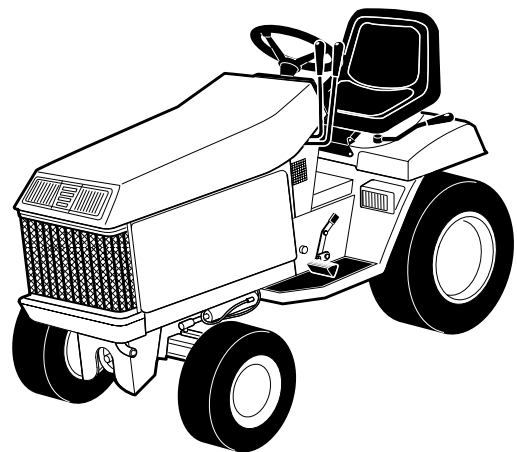

Introduction

Thank you for purchasing this product. We feel you now own one of the finest pieces of outdoor power equipment available.

All information in this manual is based on the latest product information available at the time of printing. This manual is considered a permanent part of the unit and must stay with the unit if resold. This is a safety, operation, and general maintenance manual which does not attempt to cover major repairs.

Our equipment is carefully designed, engineered and manufactured for excellent performance if properly operated and maintained.

Read this manual to familiarize yourself with the unit, its features, and operation.

The unit has passed the rigid safety standards set by the Outdoor Power Equipment Institute and an independent testing laboratory.

The unit's warranty statement is included in your literature package. Read the statement thoroughly. Also, please complete and return the postage-paid owner registration card included with this manual. This card registers each unit and owner at the factory in order to provide bulletins and safety literature.

Table of Contents

SERVICE INFORMATION	3	Light Switch	18
Unit Service and Repair	3	Moving Tractor Manually	19
Warranty Service	3	Cruise Control	19
Left and Right Sides	3	Brake/Neutral Pedal	19
Engine Service	3	LUBRICATION AND MAINTENANCE	20
Repair Manual	3	Checking Engine Oil Level	20
Replacement Owner Manual	3	Changing Engine Oil	20
SPARK ARRESTER WARNING	3	Changing Engine Oil Filter	20
IDENTIFICATION NUMBERS	3	Engine Air Intake Screen	21
SAFETY	4	Engine Air Cleaner	21
SAFETY DECAL	9	Fuel Filter	21
ATTACHMENTS, KITS AND SPECIFICATIONS	10	Carburetor	22
CONTROLS	12	Battery	22
BEFORE OPERATION	14	Spark Plugs	22
OPERATION	16	Front Axle Adjustment	22
Starting Engine	16	Front Wheel Alignment	22
Throttle Setting	16	Power Steering	22
Stopping Engine	16	Proper Jack Placement	23
Interlock System	17	Interlock Switches	23
Perform Electric Clutch Break-in Procedure	17	Brake Adjustment	23
Attachment/PTO Drive	17	Hydrostatic Maintenance and Lubrication	23
Hydraulic Attachment Lift	17	Hydrostatic Neutral Adjustment	24
Auxiliary Hydraulic Connections	17	Lubrication Chart	25
Hydrostatic Transmission	18	Troubleshooting Chart	26
Travel Pedal	18	Storage	27
		Maintenance Chart	27

Unit Service and Repair

Contact your authorized dealer or the factory to service the unit. Provide your dealer with the unit's model/serial number and the part's description. Do not return parts directly to the factory.

Warranty Service

Warranty service is available from your authorized dealer.

Left and Right Sides

Left and right sides of the unit are determined from the operator's position, facing the direction of forward travel.

Engine Service

For engine service, contact your authorized engine dealer. To locate your authorized engine dealer, refer to the "Yellow Pages" under "Engines—Gasoline" or "Gasoline—Engines". Provide your dealer with the engine model and serial numbers.

Repair Manual

A repair manual is available from your dealer.

Replacement Owner/Operator Manual

A replacement owner/operator manual is available from the factory. To order, call or write to the address on the back cover of this manual.

Identification Numbers

For prompt service, always provide the identification numbers of the unit. The unit's identification numbers are located on a decal, beneath the seat, on the rear fender. Fill in the spaces below with these identification numbers for future reference.

Date of Purchase:

Engine Model/Serial/Spec. Numbers:

Tractor Model/ Serial Number:

Transaxle Serial Number (stamped in trans. housing):



WARNING: Engine exhaust from this product contains chemicals known to the State of California to cause cancer, birth defects or other reproductive harm.

WARNING

OPERATORS IN CALIFORNIA AND OTHER APPLICABLE STATES.

Under California law, and under the laws of several other states, it is not lawful to operate an internal combustion engine using hydrocarbon fuels on any forest covered, brush covered, or grass covered land; or on land covered with grain, hay, or other flammable agricultural crops, without an engine spark arrester installed and in continuous effective working order.

The internal combustion engine on this unit burns gasoline, a hydrocarbon fuel. Therefore, this unit must be equipped with a spark arrester muffler in continuous effective working order. The spark arrester must be attached to the engine exhaust system in such a manner that flames or heat from the system will not ignite flammable material. Failure of the owner/operator of this unit to comply with this regulation is a misdemeanor under California law, and may also be a violation of other state and/or federal regulations, laws, ordinances, or codes. Contact the local fire marshal or forest service for specific information about which regulations apply in your area.

Section 1

Safety

Important! Safe Operating Practices for This Unit



This is a safety alert symbol. It is used in this manual and on decals on the unit to alert you to potential hazards. Whenever you see this symbol, read and obey the safety message that follows it. Failure to obey the safety message could result in personal injury or property damage.

Introduction

1. **Unit is capable of amputating hands and feet and throwing objects. Failure to observe the following safety instructions could result in serious injury or death.**
2. Serious accidents which may cause injury or property damage can occur if the following safety guidelines are not followed. Operator is solely responsible for accidents or hazards that occur when using unit. Preventing accidents is the responsibility of every equipment operator. Accidents can be prevented. Be careful before, during and immediately after use of any powered equipment. The following general safety precautions must be fully understood and followed during operation. Review these instructions frequently and never take chances. If you do not understand any part of this manual or need assistance, contact your dealer or our service department.

Training



1. **Read, understand and follow all instructions in this manual and on unit before starting.** To order a replacement manual, contact the factory at the address indicated in this manual. Provide the model/serial number of unit when ordering.
2. Read and understand the operator's manual provided with each attachment used with this unit.
3. Read the engine operation and maintenance manual provided with this unit before operation. Read and follow all safety instructions provided in that manual.
4. Only allow responsible adults, who are familiar with the instructions, to operate the unit.

5. Know the location and function of all controls before operating unit. Know how to stop engine and attachments quickly in case of emergency. Familiarize yourself with all safety and operation decals on unit and attachments. If these decals are damaged or not legible, clean or replace them as needed.

Preparation

1. Wear proper clothing when operating unit. Always wear sturdy footwear (preferably steel-toed shoes) and hearing protection during operation.
 - a. Wear heavy leather gloves whenever working near or servicing any cutting edges on unit.
 - b. Do not wear loose-fitting clothing, jewelry, scarves, ties, etc., which may get caught in moving parts. Tie up or restrain long hair.
 - c. Do not operate unit while barefoot. Do not wear sandals.
 - d. Wear long trousers.
 - e. Wear hearing protection.
2. Do not operate unit when tired, ill or under the influence of alcohol and/or other drugs.
3. Be prepared for an emergency. Keep a first aid kit and fire extinguisher handy. Keep emergency telephone numbers for ambulance, fire, hospital, doctor and rescue near your telephone.

Before Operation

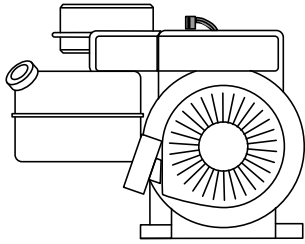

1. Before each use, clear work area of objects such as rocks, toys, wire, etc., which could be picked up and thrown by mower blades.
2. Keep unit in safe operating condition. Check the following each time before starting unit:
 - a. All hardware for tightness (especially blade mounting hardware—check for proper torque specifications frequently in this area—refer to maintenance section of attachment owners manual).
 - b. Brakes, steering and other major controls for proper operation.
 - c. Inspect mower blades for wear or damage. Broken pieces thrown from a worn or damaged blade can cause serious injury.
 - d. Check for and maintain correct tire pressure. Check tires for cuts or bubbles. Check wheels for damage or missing hardware. Repair or replace as required.
 - e. Check engine oil level and add oil as required. If oil level is below “ADD” mark, DO NOT run engine.
3. Do not operate unit or attachments without safety devices and shields in place and operating properly.
4. Only use attachments which are approved for use with this unit. Contact our service department if there is a question whether an attachment is approved for unit.

5. When using attachments, use wheel weights (where required) for extra traction and proper balance.
6. Check brake function frequently. Adjust and service as required. See “Brake Adjustment” in “Maintenance” section.
7. Unit is equipped with a safety interlock system, designed to shut off engine when operator leaves seat while an attachment is running or if parking brake is not engaged. The PTO will also automatically shut off if the travel pedal is pressed for reverse travel while the PTO switch is in the “ON” position. If the interlock system is not working properly, repair it before operating this unit.

CORRECT ANY MALFUNCTION BEFORE USING THIS UNIT OR ATTACHMENTS!

Handling Gasoline



1. **Use extra care in handling gasoline and other fuels. Gasoline and its vapors are volatile and dangerous. Keep gasoline and gasoline containers away from hot engine exhaust. Never allow flame, sparks, smoking materials or other hot objects near gasoline or gasoline fumes.**
 2. Wipe up spilled gasoline immediately. Only use approved gasoline containers.
 3. Leave two inches of air space at top of fuel tank to allow room for expansion.
 4. Store gasoline in a cool, well-ventilated area. Never store unit or fuel container inside where there is an open flame, such as a hot water heater, furnace, etc.
5. Never remove fuel fill cap, or add fuel to fuel tank, if engine is running or hot. Always replace fuel fill cap before starting engine.
 6. Never refuel unit indoors. Refuel outdoors in a well-ventilated area.

Operation

1. When starting engine:
 - a. Disengage attachment/PTO (Power Take-Off) drive.
 - b. Set parking brake.
2. Remain seated when starting engine and during operation. Always operate unit with feet flat on running boards.
3. Keep hands, feet, face, hair and clothing away from rotating parts. Stop engine before removing grass catcher or unclogging chute.
4. When operating a mower deck:
 - a. Mow only in daylight or in good artificial light.
 - b. Never dismount to make a cutting height adjustment while the engine is running.
 - c. Disengage attachment/PTO drive, shut off engine, remove ignition key and wait for all moving parts to stop before unclogging discharge chute, mounting grass catcher or Grass Reduction System (GRS).
5. Disengage attachment/PTO drive when transporting unit to work area or when attachments are not in use.
6. Be aware of attachment discharge direction and do not point it at anyone. Do not operate mower decks

Safety (continued)

without either the entire grass catcher or the guard in place.

7. If you strike a foreign object, disengage attachment/PTO drive, shut off engine, wait for all moving parts to come to a stop. Remove ignition key. Inspect for and repair any damage before operating equipment again.
8. Never carry passengers. Passengers interfere with the safe operation of this unit. Passengers could be struck by foreign objects and/or thrown from unit and could be severely injured.
9. Be sure area is clear of other people before mowing. Stop machine if anyone enters the area. Do not operate unit with children, pets or others nearby.
10. The unit is equipped with a safety interlock system disallowing it to mow in reverse. The PTO will automatically shut off if the travel pedal is pressed for reverse travel.
11. Approach blind corners cautiously.
12. Always observe the terrain. Watch for and avoid obstacles. Stay away from holes, ditches, soft or steep embankments and other potentially dangerous terrain. Tall grass can hide obstacles.
13. Wet surfaces reduce traction and stability. Always maintain proper traction. Grip the steering wheel firmly.
14. Slow down before turning.
15. Do not install an automotive-type ball hitch on this unit. When pulling loads:
 - a. Use approved hitch points.
 - b. Limit loads to those which can be safely controlled.
16. Watch out for traffic when operating near or crossing roadways.

17. Never leave a running machine unattended. Always turn off attachment/PTO drive, set parking brake, stop engine and remove key before dismounting.

Children



1. **Tragic accidents can occur if the operator is not alert to the presence of children. Children are often attracted to the machine and the mowing activity. Never assume that children will remain where you last saw them.**
2. Never allow children to operate this unit, even under adult supervision. Local regulations may restrict operator age. Only allow responsible adults, who are familiar with these instructions, to operate this unit.
3. **Never carry children as passengers.** Do not carry ANY passengers. They may fall off and be seriously injured or interfere with safe machine operation.
4. Keep children out of the work area and under the watchful care of another responsible adult.
5. Be alert and turn machine off if children enter the area.
6. Before and when backing, look behind and down for small children.
7. Use extra care when approaching blind corners, shrubs, trees or other objects that may obscure vision.
8. Keep children away while performing maintenance or adjustments.

Slope Operation



1. **Slopes are a major factor in loss-of-control and tip-over accidents which can result in severe injury or death. All slopes require extra caution. If you cannot back up the slope or if you feel uneasy on it, do not operate this unit on the slope.**
2. Remove obstacles such as rocks, tree limbs, etc.
3. Watch for holes, ruts, or bumps. Uneven terrain could overturn the machine. Tall grass can hide obstacles.
4. Always mow up and down the face of slopes, never across. Do not mow near drop-offs, ditches or embankments. The unit could suddenly overturn if a wheel goes over the edge of a cliff or ditch, or if an edge caves in.
5. When using attachments on slopes, use wheel weights, as indicated in Section 2, "Attachments and Kits", for extra traction and correct balance.
6. Do not turn on slopes unless necessary, and then, turn off attachment drive and turn slowly and gradually downhill.
7. Do not start or stop suddenly when going up or down a slope. Keep all movement on slopes slow and gradual. Do not make sudden changes in speed or direction.

8. If unit is unable to continue moving uphill, disengage attachment drive (PTO), check area on ground immediately behind unit, watch area to rear and proceed backward slowly.
9. Do not operate unit on steep slopes where there is a risk of an overturn. **Do not mow slopes with an incline of more than 10°.** Use the Slope Gauge, included with your unit, as an aid in determining the incline of a slope.
10. Use extra care with grass catchers or other attachments. These can change the stability of unit.
11. Do not operate unit on wet grass. Reduced traction could cause sliding.
12. Do not try to stabilize unit by putting your foot to the ground.
13. Do not park unit on a hill.

Stopping

1. Before leaving operator's position or before leaving tractor unattended:
 - a. Bring unit to a complete stop.
 - b. Disengage attachment/PTO drive.
 - c. Lower attachments to ground.
 - d. Set parking brake.
 - e. Shut off engine and remove ignition key.
 - f. Wait for all moving parts to come to a complete stop.
2. Disengage attachment/PTO drive when transporting tractor or when attachments are not in use.

Maintenance

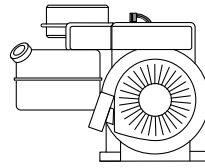

⚠ WARNING

BEFORE PERFORMING ANY MAINTENANCE OR ADJUSTMENTS TO THE TRACTOR, ENGINE OR ATTACHMENTS: DISENGAGE THE ATTACHMENT/PTO DRIVE, SHUT OFF THE ENGINE AND WAIT FOR ALL MOVING PARTS TO STOP. SET THE PARKING BRAKE AND ALLOW THE ENGINE AND MUFFLER TO COOL.

1. **Before performing any service, adjustments or maintenance on unit, engine or attachments:**
 - a. **Park unit on a firm and level surface.**
 - b. **Disengage attachment (PTO) drive.**
 - c. **Lower attachments.**
 - d. **Move all control levers to "Neutral".**
 - e. **Apply parking brake.**
 - f. **Shut off engine. Remove ignition key and allow engine to cool.**
2. Always wear sturdy footwear (preferably steel-toed shoes), long trousers, hearing and eye protection while doing any maintenance on unit. Do not wear loose-fitting clothing, jewelry, scarves, ties, etc., which could get caught in moving parts. Tie up or restrain long hair.
3. Mower blades are extremely sharp. Use caution when servicing. Wear gloves or wrap blades in rags. Wear eye protection when sharpening blades.

4. Keep children away while performing maintenance or adjustments.
5. Provide safe, adequate light in your work area. **NEVER USE AN OPEN FLAME FOR ILLUMINATION!** Use only a portable safety light enclosed in a wire cage for working inside or under unit.

NOTE: Hot filaments from a broken light bulb can ignite spilled fuel or oil.

6. Never "feel" for hydraulic system leaks. Hydraulic fluid could leak at high pressure and temperatures and could penetrate and burn skin.
7. Keep nuts and bolts tight (especially blade mounting hardware—check for proper torque specifications frequently in this area—refer to maintenance section of attachment owners manual). Keep equipment in good condition.
8. Never tamper with safety devices. Check their proper operation regularly. Repair or replace as necessary.
9. Keep machine free of grass, leaves or other debris build-up. Clean up oil or fuel spillage. Allow machine to cool before storing.
10. Grass catcher components are subject to wear, damage and deterioration, which could expose moving parts or allow objects to be thrown. Check their proper operation regularly. Repair or replace as necessary.
11. Frequently check components and replace when necessary. Use only factory- approved replacement parts. Parts manufactured by others may present safety hazards even though they may fit on the unit.
12. Replace muffler if worn or defective.
13. Keep all safety and operation decals in place. If these decals are damaged or not legible, clean or replace them as needed.

Safety (continued)

14. Check brake operation frequently. Adjust and service as necessary as indicated in Section 7 "Maintenance."
15. Chock wheels (place blocks of wood in front and behind wheels) when performing maintenance with the parking brake off. Securely support unit if it must be raised for any reason.
16. Check wheel attachment hardware regularly and ensure it is properly secured.
17. Do not attempt to mount a tire on a wheel rim unless you are experienced in doing so. Follow proper safety precautions and use proper tools. Mounting a wheel improperly could result in serious injury or death.
18. Do not inflate tires above recommended pressures. Use a clip-on chuck to inflate tires, with an extension hose long enough to allow you to stand to one side and NOT over or in front of the tire assembly.
19. Towing or pushing unit with another vehicle will damage transmission. Push unit by hand only.
20. Use a heavy-duty trailer to transport unit. Lower attachments to trailer bed. Set parking brake. Fasten unit securely to trailer with straps, chains or cables. Unit must be secured to trailer facing forward.
21. Use extra care when loading or unloading the machine into a trailer or truck.
22. Do not use food or beverage containers to store waste materials. Using such containers could result in accidental poisoning.

Engine

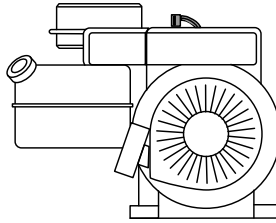

1. Read the provided engine operation and maintenance manual completely before operation. Read and follow all safety instructions provided in that manual.
2. BEFORE SERVICING ENGINE: Disconnect spark plug wire and keep it from touching spark plug.
3. Keep engine free of grass, leaves, oil and grease.
4. Engine exhaust is extremely hot. Keep grass, oil, fuel and other combustible materials far away from engine exhaust.
5. Do not change engine governor setting. Over-revving may damage engine and will void warranty.
6. Never run an internal combustion engine inside a closed area. Engine exhaust contains carbon monoxide gas, a deadly poison. Carbon monoxide is odorless, colorless and tasteless. Do not operate unit near buildings, windows or air conditioners. If engine is run in a garage, open all doors and allow for adequate ventilation.

Battery

⚠ DANGER

BATTERIES PRODUCE EXPLOSIVE GASSES. KEEP OPEN FLAMES AND SPARKS AWAY. DO NOT SET TOOLS ACROSS TERMINALS.

BATTERY ELECTROLYTE CAN CAUSE SEVERE BURNS. EYE CONTACT CAN CAUSE BLINDNESS. ALWAYS WEAR EYE PROTECTION AND RUBBER GLOVES WHEN WORKING NEAR THE BATTERY. NEVER WEAR JEWELRY.

IF ELECTROLYTE CONTACTS SKIN OR EYES, RINSE IMMEDIATELY WITH WATER FOR AT LEAST 15 MINUTES. CALL PHYSICIAN IMMEDIATELY.

1. **BEFORE WORKING WITH ELECTRICAL WIRES OR COMPONENTS: Disconnect the battery ground (negative) cable first. Disconnect the positive cable second. The battery ground (-) cable must be disconnected first and reconnected last.**
2. Before attempting to charge battery, understand and follow correct procedure or bring battery to a factory-authorized dealer for charging. Do not charge a frozen battery.
3. Battery electrolyte can cause severe burns. Eye contact can cause blindness. Always wear approved safety goggles when working around the battery.

4. If electrolyte contacts skin or eyes:
 - a. Flush affected area with water.
 - b. Apply baking soda to neutralize acid.
 - c. Flush eyes with water for 10-15 minutes.
 - d. Call a physician immediately.
5. If electrolyte is swallowed:
 - a. Drink large amounts of water or milk.
 - b. Follow by drinking milk of magnesia, beaten eggs or vegetable oil.
 - c. Call a physician immediately.
6. Electric storage batteries give off highly explosive hydrogen gas while charging and continue to do so for some time after receiving a steady charge. Do not, under any circumstances, allow an electric spark or an open flame near the battery. Do not lay tools across the battery terminals as this may result in a spark or a short circuit which may cause an explosion.

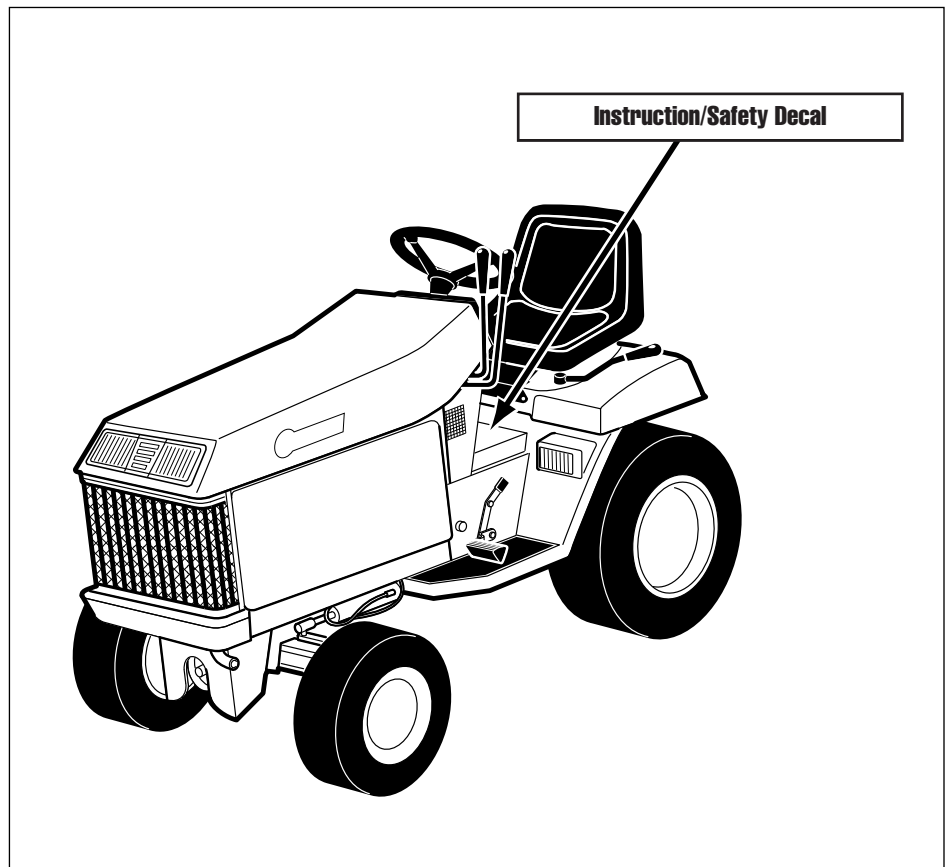

Storage

1. Do not store unit inside a building where fumes from fuel in fuel tank may reach an open flame or spark. Allow unit to cool before moving it inside an enclosure. Use a gasoline storage stabilizer when storing unit.
2. Keep unit and fuel supplies securely locked away to help prevent access by children.
3. Remove ignition key.
4. Disconnect battery cables or remove battery if unit is to be stored for an extended period. Remove negative (ground) cable first. Re-connect negative (-) cable last.
5. Fully charge battery before storage. Store battery in a cool, dry place, out of reach of children.

Safety Decals

Read and understand the instructions and safety information on decals placed on the unit. Keep safety and instruction decals clean, legible, and intact. If the decals are worn or illegible, order replacements and place them on the unit.

NOTE: MAINTENANCE DECAL IS UNDER HOOD.

Attachment, Kits and Specifications (continued)

Below is a list of attachments and kits available for this tractor. The information below is the most current, available at the time this manual was printed. Check with your nearest authorized dealer for current information.

Number	Description
14025	42" Side Discharge Mower
14026	48" Side Discharge Mower
14030	48" Rear Discharge Mower
14061	60" Side Discharge Mower (13076 only)
14032	Grass Reduction System (42" and 48" mowers)
14058	Power Packer Plus (Grass Collector)
14070	Grass Collection Cart
14069	2-Bag Grass Collector (requires 14058)
14065	33" Tiller
1767079	8" Hood and Tine Extension (for 14065)
14071	Sleeve Hitch
14072	3-Point Hitch
14073	Weight Carrier
1319B	Carrier Weights
14066B	Front End Loader (requires 14073 and 1319) (13076 only)
14075	Cab
14091	Front Wheel Weights
14090	Rear Wheel Weights (50 lb.)
16219	Tire Chains (23" Turf)
14067	Push Arm Kit
14074	Agricultural Wheel and Tire Kit
1767510	Arm Rest Kit
14101	54" Snow Blade (requires 14067)
1767251	Mechanical Angling Kit for 14101 (requires 14067)
14102	Hydraulic Angling Blades (13076 only)
14062	42" Snow Thrower (requires 14067)
14100	46" Snow Thrower (requires 14067)
14076	Dump Cart
14077	Storage Cover
1766549	Male Quick Hitch

Section 3

Controls

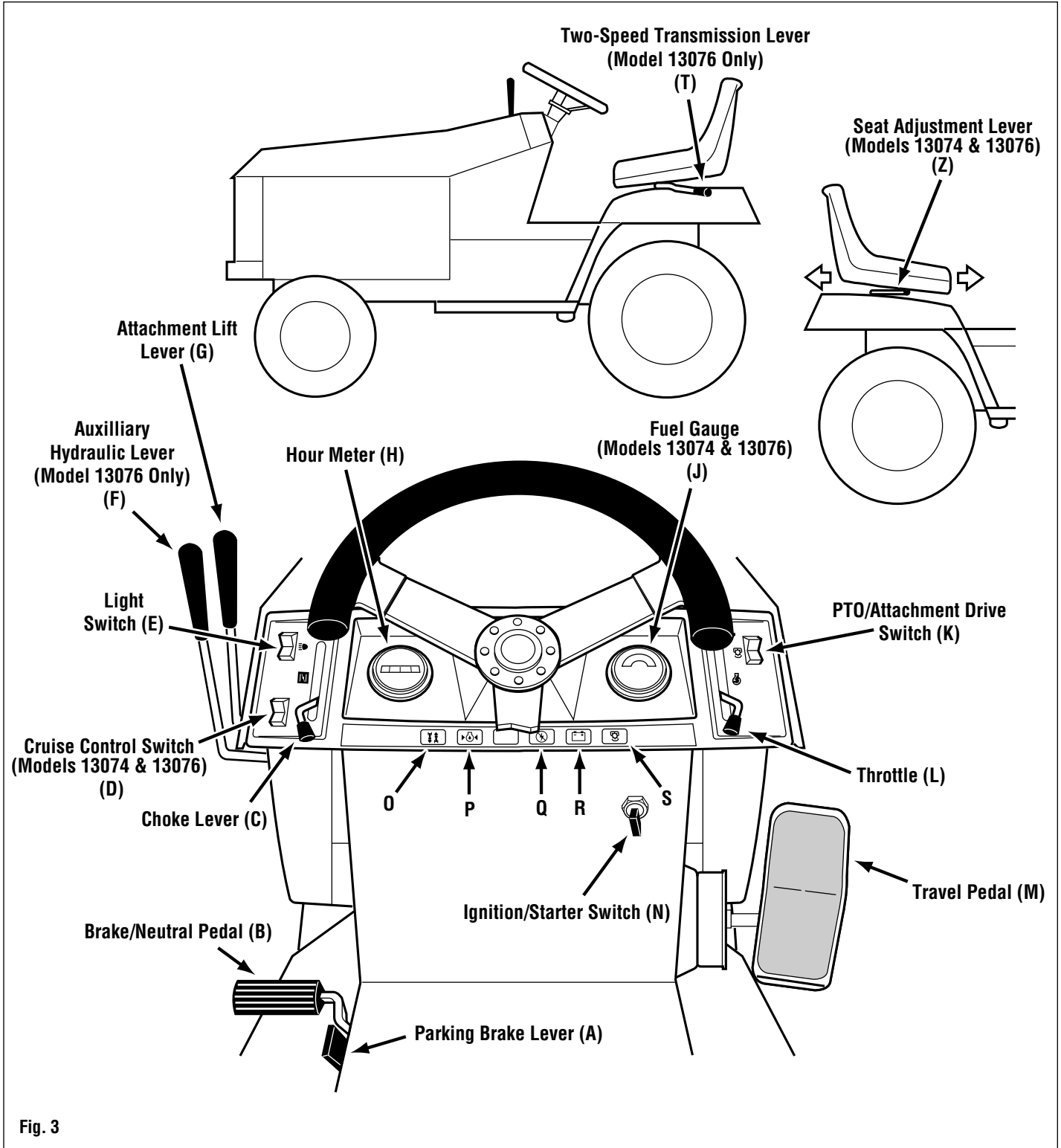

Identification and Function of Controls and Features

Before operating this tractor, become familiar with the function and location of each control. This will help ensure proper, safe and efficient operation. See the "Operation" section for instructions.

- A. Parking Brake Lever**
Locks brake. Set parking brake when unit is not in use. See page 19 for operating instructions.
- B. Brake / Neutral Pedal**
Stops forward or reverse movement of the tractor. See page 19.
- C. Choke Lever**
When activated, the choke restricts amount of air mixing with fuel. Activate choke when starting a cold engine. Once engine is started, move lever slowly to "OFF". See "Starting Engine" on page 16 for instructions.
- D. Cruise Control Switch (13074 & 13076)**
The cruise control allows the operator to maintain a constant drive speed without contacting the travel pedal. When activated, the cruise control sets the travel pedal at the desired position. See page 19 for instructions.
- E. Light Switch**
Activates headlights.
- F. Auxiliary Hydraulic Lever (Model 13076)**
Activates the auxiliary hydraulics. See page 17 for instructions.
- G. Attachment Lift Lever**
Controls the hydraulic attachment lift. See page 17.
- H. Hour Meter**
Registers hours of tractor use.
- J. Fuel Gauge (13074 & 13076)**
Indicates the amount of fuel in the fuel tank.
- K. Attachment/PTO Drive Switch**
Engages and disengages power to attachments.
- L. Throttle**
Controls engine speed. Always operate engine at full throttle  when operating attachments. See page 16 for instructions.
- M. Travel Pedal**
Controls forward and rearward movement of tractor. See page 18.
- N. Ignition / Starter Switch**
Starts engine. See page 16 for engine starting instructions.
- O. Cruise Control Light (13074 & 13076)**
Indicates when cruise control is on.
- P. Oil Pressure Light (13074 & 13076)**
IF LIGHT IS ON, STOP ENGINE IMMEDIATELY. When lit, indicates a lack of oil pressure in the engine. Engine damage may result. Service before re-starting.
- Q. Start Light**
Indicates when ignition switch is in the start position and safety start interlock switches are not activated.
- R. Battery Light**
When lit, indicates low battery voltage.
- S. Attachment/PTO Drive Light**
When lit, indicates attachment/PTO drive is activated.
- T. Two-Speed Transmission Lever (Model 13076)**
Lever is located under seat, on the left side. Shifts transmission into low range or high range. See "Hydrostatic Transmission" on page 18.
- Z. Seat Adjustment Lever (13074 & 13076)**
Locks and releases seat for adjustment. Lift lever to slide seat forward or backward. See page 19.

Before Operation

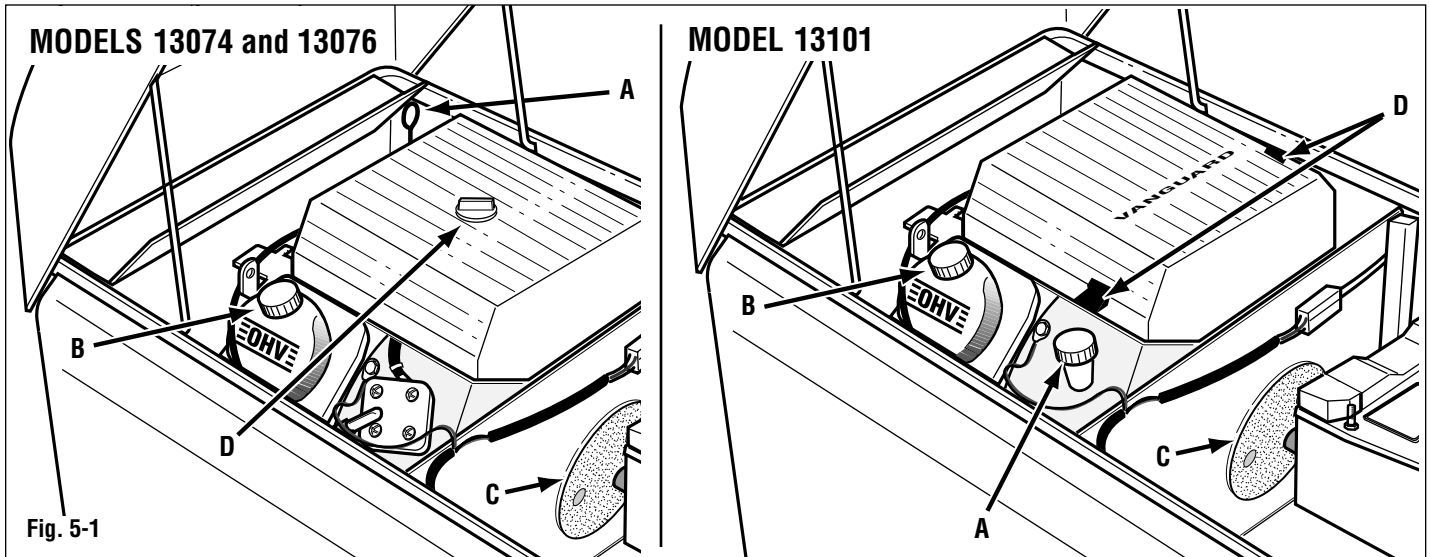

⚠ DANGER

BEFORE OPERATION, READ AND UNDERSTAND ALL CONTROL, OPERATING, AND SAFETY INSTRUCTIONS IN THIS MANUAL. READ ALL MATERIAL PROVIDED WITH ANY ATTACHMENTS USED WITH THE UNIT. READ AND FOLLOW ALL INSTRUCTIONS ON THE DECALS ON THE UNIT AND ATTACHMENTS.

⚠ DANGER

BEFORE CLEANING, PERFORMING ANY MAINTENANCE, ADJUSTING, CHECKING OR ADDING FLUIDS TO THIS UNIT, SHUT THE ENGINE OFF AND WAIT FOR ALL MOVING PARTS TO STOP.

Before starting the engine, perform the following steps:

1. Check Engine Oil Level

Refer to your specific model in Figure 5-1.

Remove dipstick (A, Fig. 5-1). Wipe oil from dipstick with a clean cloth. Insert dipstick back into place. Remove dipstick and check oil level. Keep level between the ("F" Full) and ("L" Add) marks on the dipstick. If level is low, fill engine crankcase through fill opening (B).

Capacity w/ filter – See accompanying engine manual.

⚠ DANGER

DO NOT REFUEL TRACTOR INDOORS OR WHILE ENGINE IS RUNNING OR HOT. KEEP SMOKING MATERIALS, SPARKS AND FLAMES AWAY FROM FUEL TANK AND FUEL CONTAINER.

2. Fill Fuel Tank

Fill fuel tank with clean, unleaded gasoline with an octane rating of 87 or higher. Filler neck is at the rear of tractor. Leave about two inches of room at the filler neck for expansion.

Do not mix oil with gasoline!

Make sure the vent hole in fuel tank cap is not plugged.

3. Check Engine Flywheel Screen

STOP ENGINE BEFORE CLEANING FLYWHEEL! Check engine flywheel screen (C, Fig. 5-1) for debris. Clean regularly.

Lift seat adjustment lever (Z) and slide seat forward or backward.

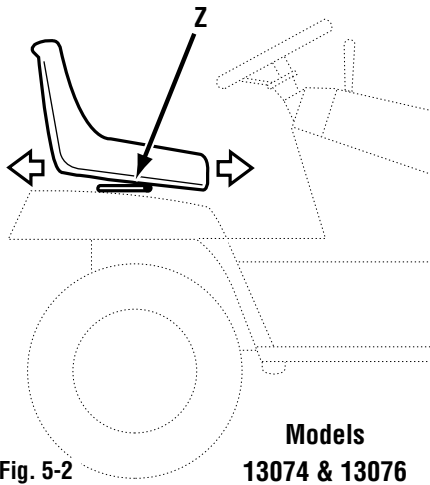

Fig. 5-2

Models
13074 & 13076

Loosen adjustment knobs (ZZ), slide seat forward or backward.

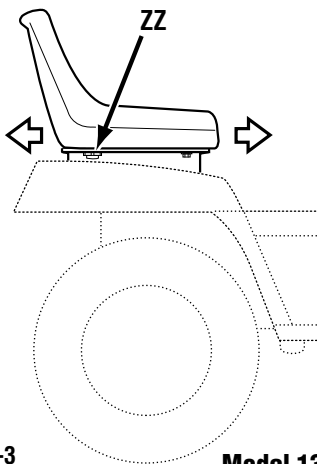

Fig. 5-3

Model 13101

4. Visually Check

Check for and repair loose or missing screws, nuts, and damaged parts.

5. Check Battery

To connect the battery initially, remove the red (+) terminal cover from the (+) positive terminal and connect the red battery cable to this terminal. Tighten the hardware before sliding the boot over the terminal.

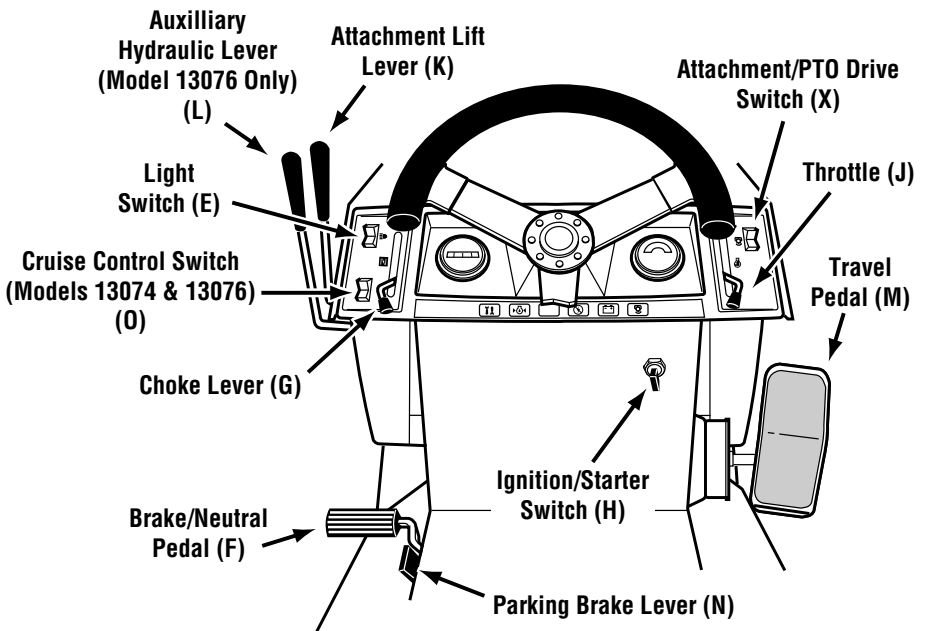

Fig. 5-4

Next, remove the black (-) terminal cover from the battery and connect the black (-) battery cable. Tighten the hardware. If cables are corroded, clean them. See "Battery", page 22.

6. Check Tire Pressure

Front – 12 to 14 PSI (82 to 96 kPa)
Rear – 8 to 10 PSI (55 to 68 kPa)

7. Adjust Seat

Models 13074 & 13076 - To adjust seat, lift lever (Z, Fig. 5-2) and slide seat forward or backward. Release lever.

Model 13101 - To adjust seat, loosen adjustment knobs (ZZ, Fig. 5-3) and slide seat forward or backward. Tighten adjustment knobs.

8. Perform Electric Clutch Break-in Procedure

Perform this step before initial use and after extended storage. Before operating unit, start engine as instructed on page 16. With the engine running at full speed, engage and disengage attachment/PTO drive switch (X, Fig. 5-4) 10 to 15 times.

⚠ DANGER

BATTERIES PRODUCE EXPLOSIVE GASSES. KEEP OPEN FLAMES AND SPARKS AWAY. DO NOT SET TOOLS ACROSS TERMINALS.

BATTERY ELECTROLYTE CAN CAUSE SEVERE BURNS. EYE CONTACT CAN CAUSE BLINDNESS. ALWAYS WEAR EYE PROTECTION AND RUBBER GLOVES WHEN WORKING NEAR BATTERY. NEVER WEAR JEWELRY.

IF ELECTROLYTE CONTACTS SKIN OR EYES, RINSE IMMEDIATELY WITH WATER FOR AT LEAST 15 MINUTES. CALL PHYSICIAN IMMEDIATELY.

Operation

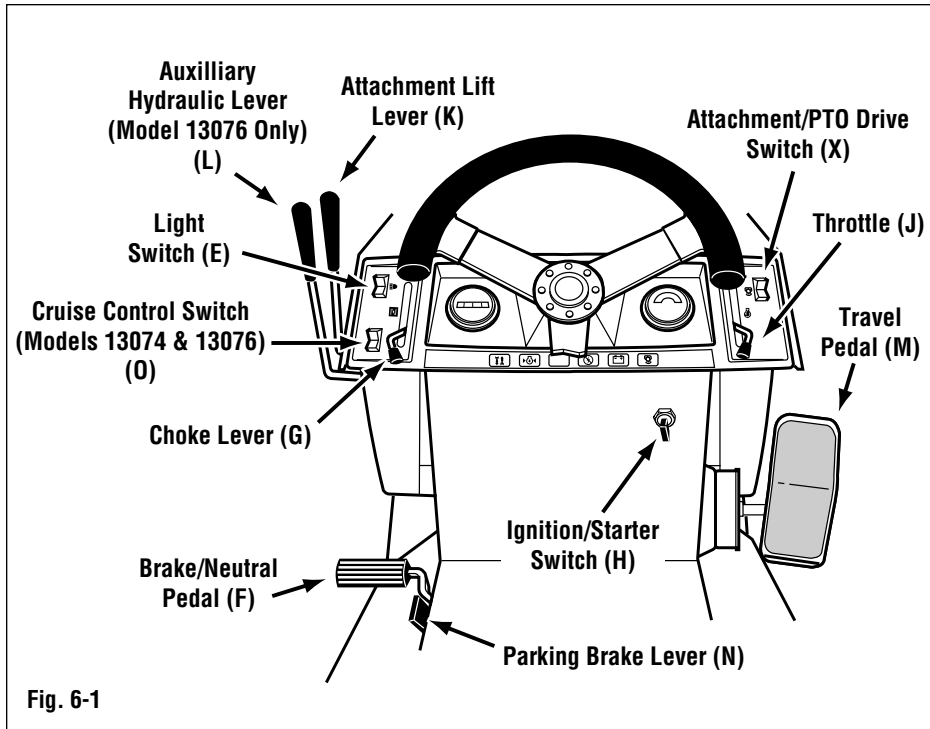

- When engine starts, move choke lever (G) down halfway (to half choke). Gradually, move choke lever down (to choke off) as the engine warms up.

NOTE: DO NOT RUN ENGINE WITH CHOKE ON FOR PROLONGED PERIODS. ENGINE WILL RUN POORLY (OVER-RICH FUEL MIXTURE) IF OVER-CHOKED.

- Move throttle (J) up to  (fast). Run the engine at full throttle (fast) for maximum engine efficiency.

Do not drive the tractor immediately after start up. Allow the engine to run for a few minutes. This allows the transmission oil to warm up.
- Perform the electric clutch break in procedure as instructed on page 17.

Throttle Setting

ALWAYS OPERATE WITH THE ENGINE AT FULL THROTTLE (FAST). While operating under heavy load conditions, listen to the engine RPM. If the engine begins to slow down, do not advance the travel pedal. Let up on the travel pedal. This will decrease the ground speed and increase the engine speed.

Stopping Engine

- Turn attachment/PTO drive switch (X, Fig. 6-1) to "OFF".
- Move throttle (J) down to  (Slow). Lock brake/neutral pedal (F, Fig. 6-1 and 6-5) down by pulling parking brake lever (N) to the rear. (See Fig. 6-5, page 19.)
- Idle engine for at least 30 seconds to allow engine to cool.
- Turn ignition/starter switch (H) to off. Remove ignition key.

Starting Engine

- Move the attachment/PTO drive switch (X, Fig 6-1) to "OFF". The starter will not activate unless this switch is off.
- Press brake/neutral pedal (F) down.
- Move choke lever (G) up. Move the throttle (J) up halfway.

NOTE: AFTER ENGINE HAS WARMED UP, OPERATE ENGINE AT  (FULL THROTTLE).

- Insert ignition key into ignition/starter switch (H). Turn key clockwise to start engine. Release key when engine starts.

False Start: If engine speeds up enough to disengage starter but fails to continue running, allow all moving parts to stop completely before engaging starter again.

Limit cranking to less than 10 seconds. If engine has been cranked for 10 seconds, allow the starter to cool for at least one minute before re-cranking. Over heating may damage starter.

WARNING

IN CASE OF A FALSE START, ALLOW ENGINE TO STOP COMPLETELY BEFORE RE-STARTING. FAILURE TO COMPLY MAY DAMAGE STARTER.

Interlock System

Leaving the seat while the attachment/PTO drive switch (X, Fig. 6-1) is on or while the brake is off will stop the engine.

⚠ WARNING

DO NOT OPERATE THE UNIT IF THE INTERLOCK SYSTEM DOES NOT FUNCTION PROPERLY.

Interlock System Test Procedure: With the engine running, stop tractor on a level surface (do NOT engage brake) and raise yourself off the seat. Engine should stop. Engage brake and press the attachment/PTO drive switch (X, Fig. 6-1) to "ON". Raise yourself off the seat. Engine should stop. If the engine does not stop in both instances, do not operate the unit. Have the interlock repaired. With engine running and PTO drive switch (X, Fig. 6-1) in the "ON" position, move the travel pedal (M, Fig. 6-1) into the reverse travel position. The PTO should automatically shut off. If it doesn't, do not operate the unit and have the interlock repaired.

Perform Electric Clutch Break-in Procedure

Start the engine as instructed on page 16. With the engine running at full (fast) speed, engage and disengage attachment/PTO drive switch (X, Fig. 6-1) 10 to 15 times. Perform this step before initial use and after extended storage.

Attachment/PTO Drive

To engage the attachment/PTO drive, press attachment/PTO drive switch (X, Fig. 6-1) to "ON".

Hydraulic Attachment Lift

Pull attachment lift lever (K, Fig. 6-1) back to lift attachment. Push lever forward to lower attachment. When lever is released, it will return to neutral, except when

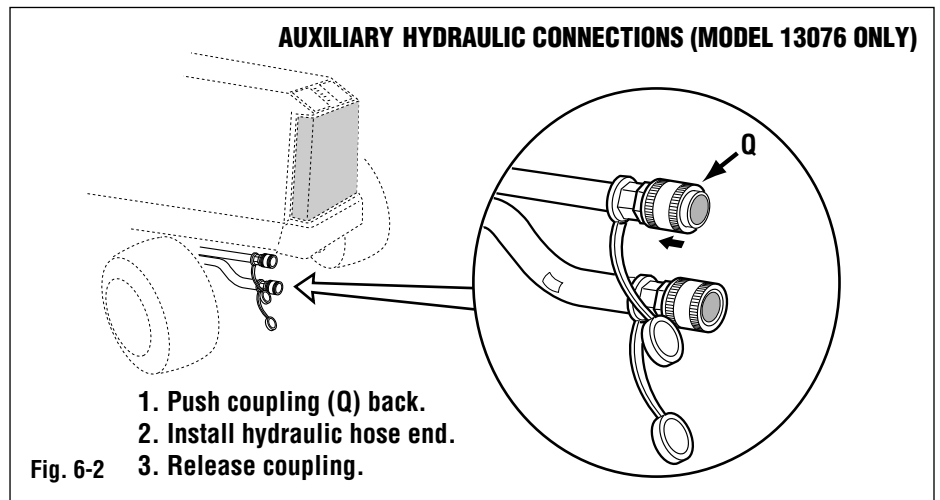

pushed fully forward to "FLOAT" position.

Use the "FLOAT" position to allow the attachment to follow ground contours.

Auxiliary Hydraulic Lever (20 HP Units):

Pull auxiliary hydraulic lever (L) back to activate auxiliary hydraulic attachment. Push lever forward to reverse direction.

⚠ WARNING

BEFORE USING HYDRAULIC LEVERS, MAKE SURE THE ATTACHMENT IS COMPLETELY HOOKED UP. MOVE ATTACHMENT THROUGH THE COMPLETE LIFT RANGE SLOWLY TO MAKE SURE THERE IS NO INTERFERENCE. MAKE ADJUSTMENTS IF NECESSARY.

Auxiliary Hydraulic Connections (Model 13076 Only)

Connections for auxiliary hydraulics (see Fig. 6-2) are on the front, right-side of the frame.

To use these connections, remove rubber plugs. Clean all dirt and debris from around connections. Push coupling (Q) back. Insert hydraulic hose end.

When auxiliary connections are not in use, secure the rubber plugs over the

connections to prevent debris from entering the hydraulic system.

KEEP HYDRAULIC CONNECTIONS CLEAN.

Dirty hydraulic connections can contaminate the hydraulic fluid and damage hydraulic components.

⚠ WARNING

DIRTY HYDRAULIC CONNECTIONS CAN CONTAMINATE THE HYDRAULIC FLUID AND DAMAGE HYDRAULIC COMPONENTS. KEEP RUBBER PLUGS IN PLACE. NEVER USE HANDS TO FEEL FOR HYDRAULIC LEAKS. HOT HYDRAULIC FLUID LEAKING AT HIGH PRESSURE COULD PENETRATE SKIN.

USE ONLY TROY-BILT® APPROVED ATTACHMENTS. Other attachments could damage the hydraulic system and void the warranty.

INSPECT ALL HYDRAULIC COMPONENTS FOR HIGH PRESSURE LEAKS BEFORE TESTING OR REPAIRING. Never "feel" for leaks. Oil leaking at high pressure could penetrate skin. Operating temperatures of hydraulic fluids are extremely high.

Operation (continued)

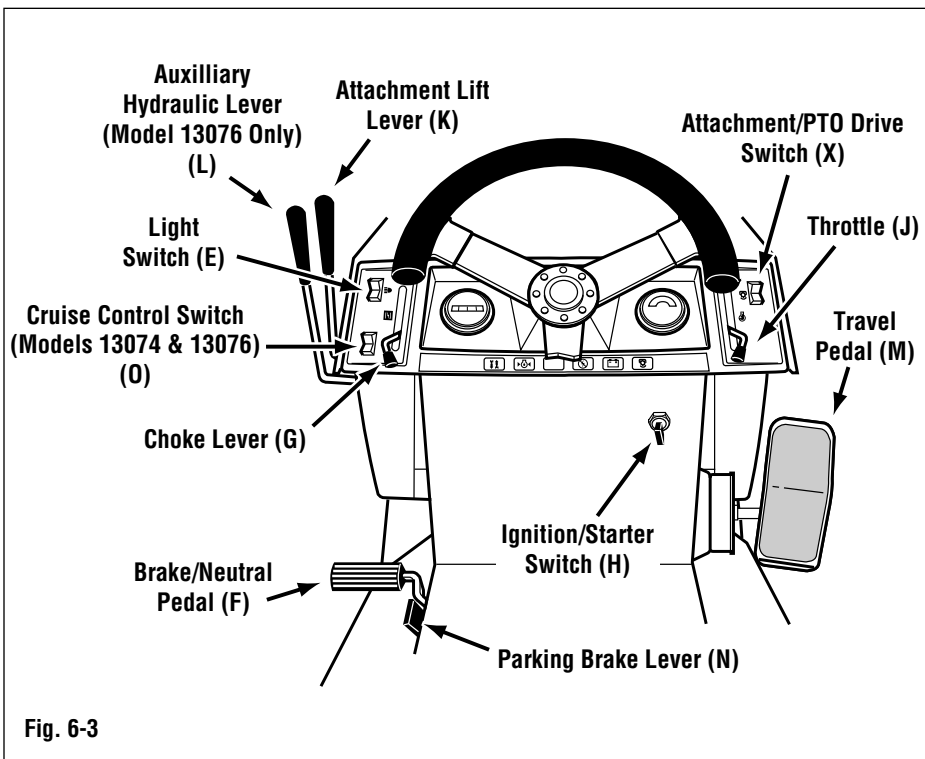

Hydrostatic Transmission

For maximum performance when using attachments, operate engine at , full throttle (FAST). Control ground speed with the travel pedal (M).

The hydrostatic transmission provides the operator with an infinite choice of travel speeds. Avoid fast travel speeds when using attachments. Operate at slower travel speeds when snow throwing, mowing and tilling.

2-Speed Models (Model 13076 Only):

Stop tractor when shifting. Change speeds with the transmission lever (P, Fig. 6-4).

Use "HIGH" range (0-9 mph) for transport and mowing.

Use "LOW" range (0-3.3 mph) for heavy load conditions such as tilling, snow throwing, plowing or using the front end loader.

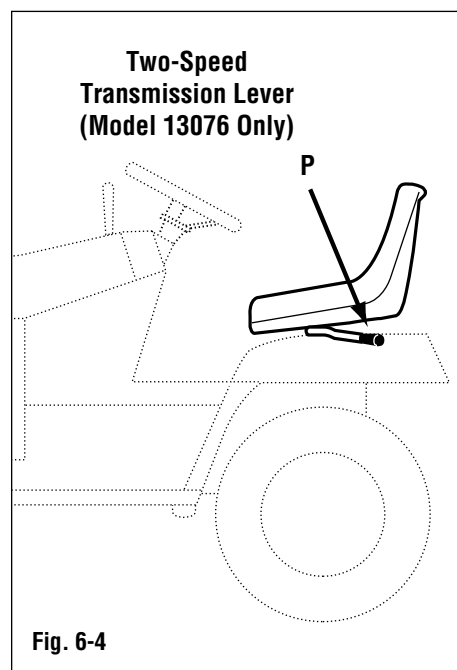

Travel Pedal

The travel pedal controls forward and rearward movement of tractor. The hydrostatic transmission gives the operator an infinite choice of travel speeds. Press travel pedal (M, Fig. 6-3) at the top (with toe) to move forward. Press pedal at the bottom (with heel) to move in reverse.

To stop or slow down when moving forward: Press pedal at bottom (with heel).

To stop or slow down when in reverse: Press pedal at top (with toe).

Light Switch

To activate lights, press light switch (E, Fig. 6-3) to "ON".

Moving Tractor Manually

DO NOT TOW OR PUSH THIS TRACTOR WITH ANOTHER VEHICLE OR RISK DAMAGING THE DRIVE SYSTEM.

When pushing the tractor, push it slowly to prevent a temporary lock-up of rear wheels.

2-Speed Models (20 HP Units): Stop tractor when shifting. Shift transmission lever (P, Fig. 6-4) to neutral.

⚠ WARNING

NEVER TOW OR PUSH THIS TRACTOR WITH ANOTHER VEHICLE. DRIVE SYSTEM DAMAGE MAY RESULT.

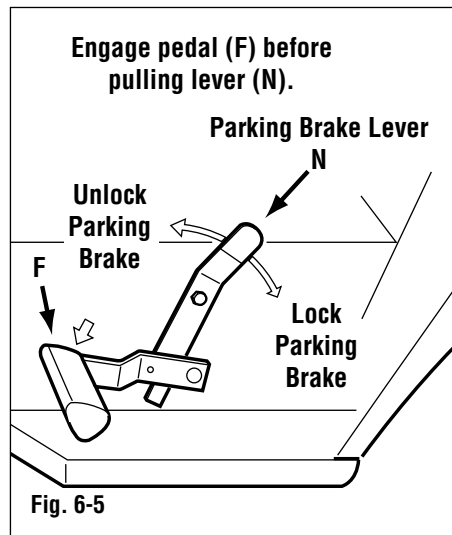

Cruise Control

Cruise control allows the operator to maintain a constant drive speed without contacting the travel pedal. When activated, the cruise control sets the travel pedal to the desired position.

TO SET: When tractor is moving at a desired speed, press the cruise control switch (O, Fig. 6-3) to "RESET" to activate cruise control. This sets the travel pedal.

TO STOP: Press brake pedal (F) or turn the the cruise control switch (O) "OFF".

TO RESET: To re-activate cruise control, press "RESET".

Brake / Neutral Pedal Parking Brake Lever

Press brake/neutral pedal (F, Fig. 6-3 and 6-5) to apply brake and when starting engine. To lock brake (when parked), press brake/neutral pedal and pull parking brake lever (N) to the rear, locking brake/neutral pedal down.

Lubrication and Maintenance

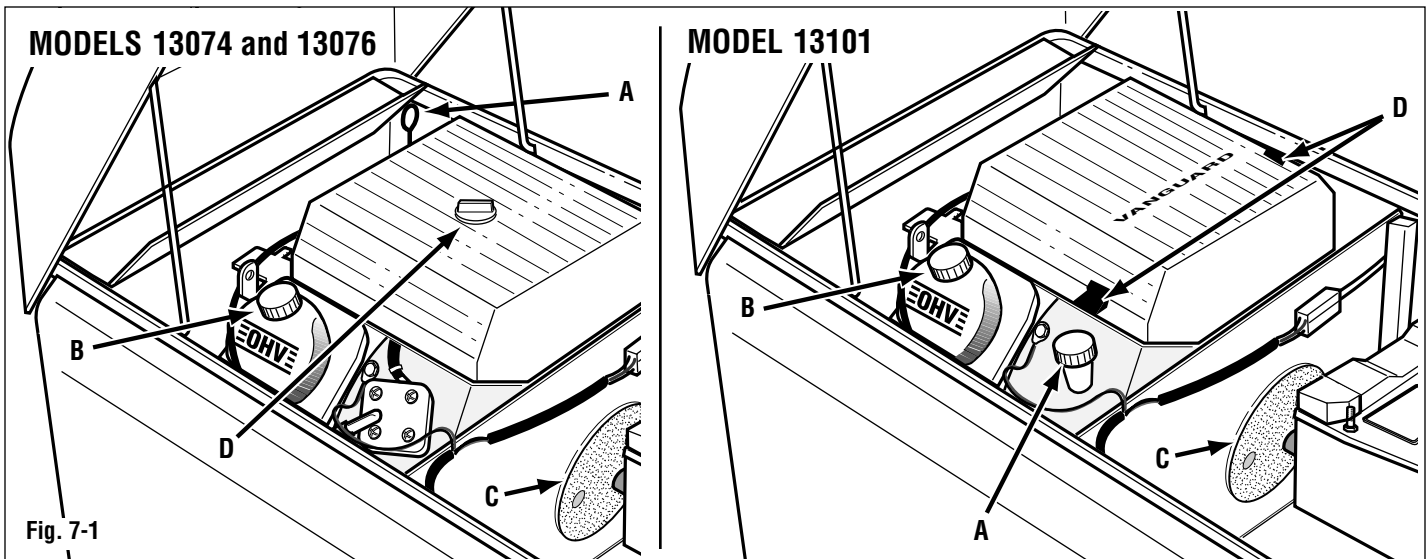

Fig. 7-1

⚠ WARNING

BEFORE PERFORMING ANY MAINTENANCE OR ADJUSTMENTS TO THE TRACTOR, ENGINE OR ATTACHMENTS: DISENGAGE THE ATTACHMENT/PTO DRIVE, SHUT OFF THE ENGINE AND WAIT FOR ALL MOVING PARTS TO STOP. SET THE PARKING BRAKE AND ALLOW THE ENGINE AND MUFFLER TO COOL.

Preventive maintenance encourages a longer operating life and better performance.

For more specific engine maintenance instructions, refer to the engine manual included with this unit.

To Check Engine Oil Level

Refer to your specific model in Figure 7-1.

The engine oil level must be in the safe range between ("F" Full) and ("L" Add) marks on the dipstick at all times. Check before each use. To check oil level:

1. Remove dipstick (A, Fig. 7-1).

2. Wipe oil from dipstick with a clean cloth. Insert dipstick back into place.
3. Remove dipstick and check oil level. The oil level is indicated by marks on the dipstick. Keep level between the ("F" Full) and ("L" Add) marks. If level is low, fill engine crankcase through fill opening (B, Fig. 7-1).

New Engine: Change the engine oil after the first 5 hours of use, then change oil every 25 operating hours.

TAKE USED OIL TO A RECYCLING CENTER. ALWAYS DISPOSE OF OIL IN AN ECOLOGICALLY FRIENDLY MANNER.

Changing Engine Oil

Change oil after the first 5 operating hours of operation and every 25 operating hours thereafter. Drain oil while it is hot. Hot oil flows more freely and carries away more impurities. To change oil:

1. To access engine from the side, remove left side panel by unscrewing and removing knobs (J, Fig. 7-3).
2. Remove yellow cap from oil drain tube (L, Fig. 7-4). Attach oil drain hose to oil drain tube.

3. Direct hose end into a container. Turn oil drain valve and drain oil.
4. Turn and close oil drain valve. Reconnect yellow cap to oil drain tube.
5. Fill engine crankcase with oil at fill opening (B, Fig. 7-1). See engine manual for the correct oil type. Fill to level indicated on dipstick, between the ("F" Full) and ("L" Add) marks. **NEVER OVERFILL ENGINE CRANKCASE.** Capacity w/ filter – See engine manual.

Changing Engine Oil Filter

Change the engine oil filter every 50 operating hours. Refer to the engine manual for filter specifications and part number. To change oil filter:

1. Remove side panel and drain oil as instructed above in steps 1 - 5.
2. Unscrew and remove old filter (M, Fig. 7-4). Wipe off filter adapter (area behind filter).
3. Apply a light coat of oil to rubber gasket on oil filter. Place new filter on filter adapter. Turn oil filter clockwise until rubber gasket contacts filter adapter. Tighten an additional 1/2 turn.

4. Close oil drain valve (L). Place cap on oil drain tube. Install side panel.

Engine Air Intake Screen

STOP ENGINE BEFORE CLEANING AIR SCREEN! Check engine air intake screen (C, Fig. 7-1) for debris and clean regularly.

A dirty air screen and engine can reduce airflow and cause the engine to overheat. See the engine manual for more specific information.

Engine Air Cleaner

IMPROPER AIR CLEANER MAINTENANCE CAN CAUSE ENGINE DAMAGE.

1. Clean dirt from around the air cleaner cover. Unscrew knob or unlatch clips (D, Fig. 7-1) and remove cover.

Pre-cleaner: Service pre-cleaner (E, Fig. 7-2) every 25 hours of operation (more often under dusty or dirty conditions). Refer to the engine manual for part number.

Paper Element: Under normal conditions, service paper element (G, Fig. 7-2) every 100 hours of operation. Replace paper element when no longer serviceable. Refer to the engine manual for replacement part number.

Service Pre-cleaner:

2. Slide foam pre-cleaner (E) off paper element (G).
3. Wash foam pre-cleaner in liquid detergent and water.
4. Rinse foam pre-cleaner and wrap in cloth. Squeeze dry. Do not wring.
5. Saturate foam pre-cleaner in clean engine oil. Squeeze to distribute and remove excess oil.

Service Paper Element:

6. Remove wing nut (F) and paper element (G).

DO NOT ALLOW DIRT TO FALL INTO THE ENGINE.

7. Clean element by gently tapping it on a flat surface. Do not damage gasket surfaces on paper element.

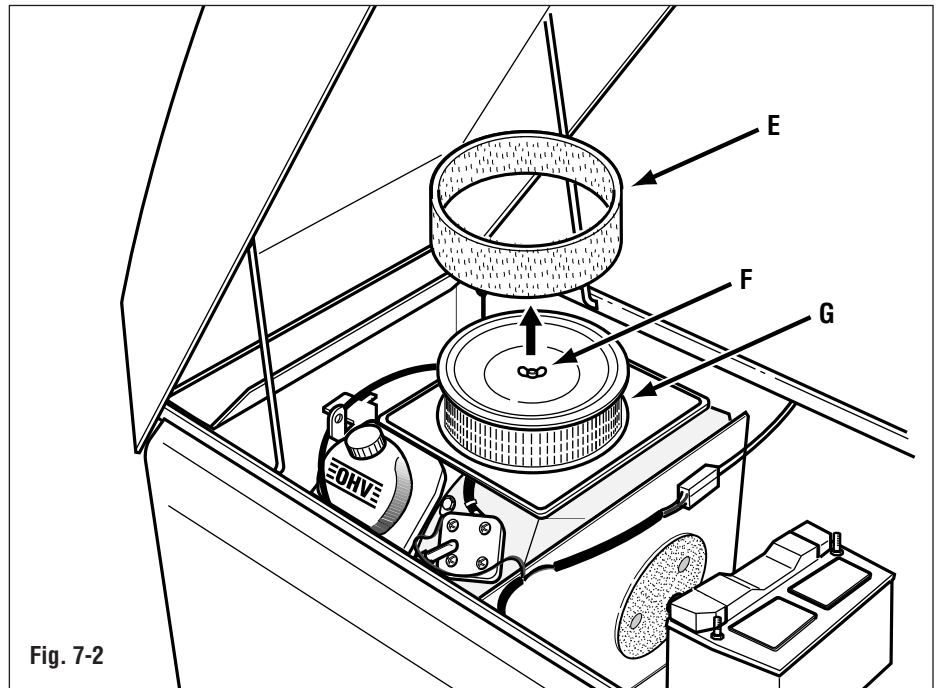

Fig. 7-2

8. Do not use petroleum solvents, oil or pressurized air to clean paper element.
9. Place cleaned (or new) paper element (G) on engine. Secure with wing nut (F). Install cleaned, oiled foam pre-cleaner (E) over paper element.
10. Install cover and screw in knob or latch clips (D, Fig. 7-1) down.

Fuel Filter

Replace fuel filter every 100 operating hours. See engine manual or your dealer for more specific information and fuel filter replacement specifications. To access fuel filter, unscrew and remove knobs (J, Fig. 7-3). Remove left side panel. Fuel filter (K, Fig. 7-4) is located along the fuel line, extending from the fuel tank. This filter is disposable. Replace when dirty.

To Replace Fuel Filter:

1. Shut off in-line valve under fuel tank.
2. Remove filter (K) from fuel line.
3. Install new fuel filter.
4. Open in-line valve after replacement.

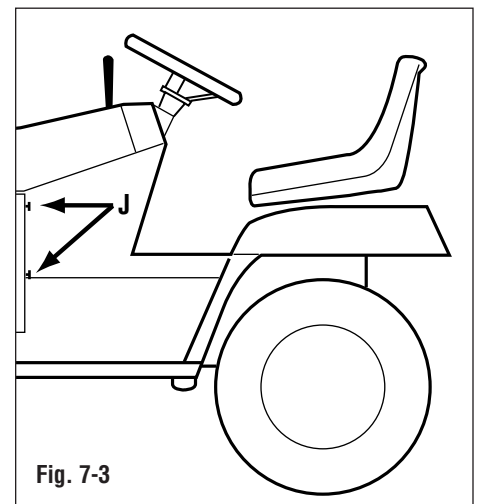

Fig. 7-3

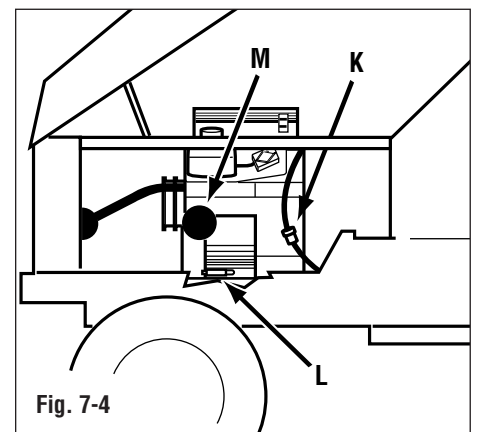

Fig. 7-4

Maintenance (continued)

Carburetor

The carburetor is adjusted at the factory. It should not need resetting. If black exhaust is noted, check the air cleaner first. An over-rich fuel mixture is usually caused by a poorly serviced or clogged air cleaner element, not an improperly adjusted carburetor. If readjustment is necessary, refer to the engine manual or see your dealer.

Battery

The battery is maintenance-free and the acid level cannot be checked. Keep cables and terminals clean. If cables are corroded, clean them.

DANGER

BATTERIES PRODUCE EXPLOSIVE GASSES. KEEP OPEN FLAMES AND SPARKS AWAY. DO NOT SET TOOLS ACROSS TERMINALS.

BATTERY ELECTROLYTE CAN CAUSE SEVERE BURNS. EYE CONTACT CAN CAUSE BLINDNESS. ALWAYS WEAR EYE PROTECTION AND RUBBER GLOVES WHEN WORKING NEAR BATTERY. NEVER WEAR JEWELRY.

IF ELECTROLYTE CONTACTS SKIN OR EYES, RINSE IMMEDIATELY WITH WATER FOR AT LEAST 15 MINUTES. CALL PHYSICIAN IMMEDIATELY.

After cleaning battery, apply a light coat of petroleum jelly or grease to terminals and over the bolt stud.

Remove battery cables before removing battery. Remove negative (-) cable first, followed by the positive (+) cable. Always check the polarity of the battery terminals. Make sure the battery is not reversed. The negative (-) cable is the ground. **ALWAYS CONNECT THE NEGATIVE (-) TERMINAL LAST.**

Charging: If the unit has not been used for an extended time period, charge the battery at 6 to 10 amps for 1 hour.

Spark Plugs

Every 100 hours remove and inspect spark plugs. Do not service a plug which is in poor condition. Best results are obtained with a new plug. Under good operating conditions, the plug will have a light gray coating or a tan deposit. A white, blistered coating could indicate engine overheating. A black (carbon) coating could indicate an over-rich fuel mixture caused by a clogged air cleaner or improper carburetor adjustment. See engine manual for spark plug specifications.

NOTE: Do not clean spark plugs in machines which use abrasive grit. Clean spark plugs by scraping, wire brushing or washing with a commercial solvent.

Front Axle Adjustment

In time, a gap may form between the bolster and front axle. See Fig. 7-5. The following adjustment can reduce play in the axle. To make adjustment:

1. Set parking brake. Securely block rear wheels. Raise front of tractor with a hoist or jack. See page 23 for jacking instructions.

2. Adjust screws (N, Fig. 7-5). These screws apply pressure to the front axle. Axle should pivot with a small amount of drag.

Front Wheel Alignment

Straighten front wheels. Loosen locknuts (Q, Fig. 7-5). Adjust tie rod (Z) so measurement (O) is 1/8" longer than measurement (P).

Power Steering

Power steering is controlled by the hydraulic system. No adjustment is necessary.

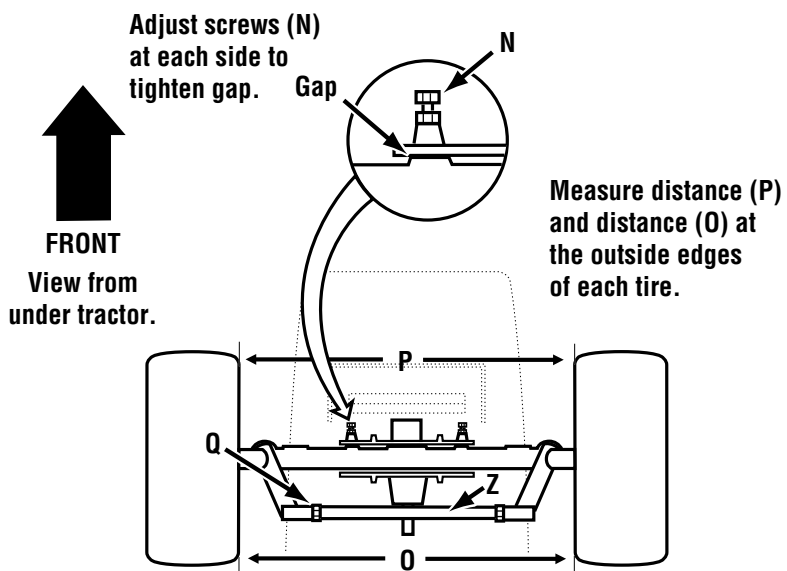

Fig. 7-5

Proper Jack Placement

A floor jack (not a bottle jack) or an overhead hoist may be used to lift the front of the tractor. Do not attempt to use any other device to lift the tractor.

⚠ WARNING

USE EXTREME CARE WHEN JACKING OR HOISTING TRACTOR. BLOCK WHEELS AND USE JACKSTANDS TO SECURELY HOLD UNIT IN PLACE.

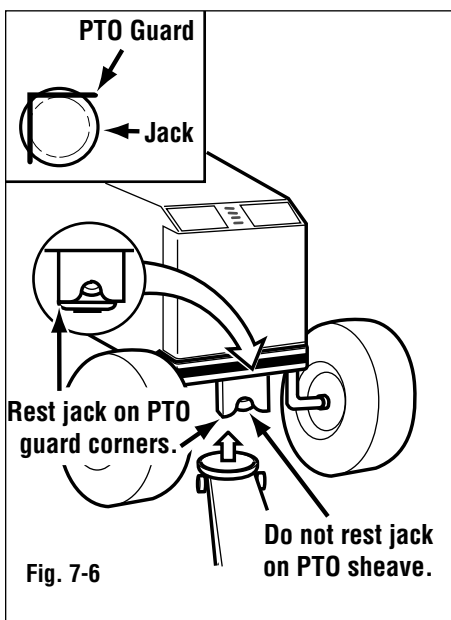

Securely block rear wheels. Rest jack on attachment/PTO drive guard corners (See Fig. 7-6). Do not rest jack on PTO sheave.

Interlock Switches

This unit is equipped with interlock safety switches to help ensure safe start-up and operation. To test interlock, see page 17.

Attachment/PTO drive switch: Interlocks are incorporated into the attachment/PTO drive switch. This switch must be off to start the engine. Also, if the travel pedal is pressed into the reverse travel position while this switch is in the "ON" position, the PTO will automatically shut off.

Seat: An interlock is positioned behind the seat. If the operator leaves the seat without locking brake/neutral pedal and turning off the attachment/PTO switch, the engine will stop.

Brake/Neutral linkage (ignition): Brake/neutral pedal must be pressed to start the engine.

Brake/Neutral linkage (cruise control): When the brake/neutral pedal is pressed, the circuit for the cruise control switch is open. All power to the cruise control is shut off.

Brake Adjustment

During normal operation of this machine, the brakes are subject to wear and will

require periodic examination and adjustment.

To adjust:

1. Turn off engine. Make sure unit is on a flat surface and block the wheels of the tractor to prevent it from rolling.
2. Move brake pedal to the disengaged (released) position.
3. To adjust yoke assembly (V, Fig. 7-7), remove clevis pin (W). Turn yoke assembly clockwise.
4. Press and release brake several times. Re-check and re-adjust as necessary.

Hydrostatic Maintenance and Lubrication

Perform the following procedure every 25 hours of operation.

1. Remove all dirt from around transmission filler area. Clean transmission cooling fins (J, Fig. 7-8). If tractor is operated in a dusty environment, check and clean cooling fins more frequently.
2. When transmission is cold, check transmission fluid level. Check level indicated on dipstick (beneath seat).

Transmission Oil: Change transmission oil after first five hours and every 100 hours thereafter. Plug is located on front side of transmission.

2-Speed Models: Fill with part number 737-0333. Alternate fluids: Mobil 423, Amoco 1000 or Texaco TDH.

1-Speed Models: Fill with part number 737-0335 or a SAE 20 weight motor oil.

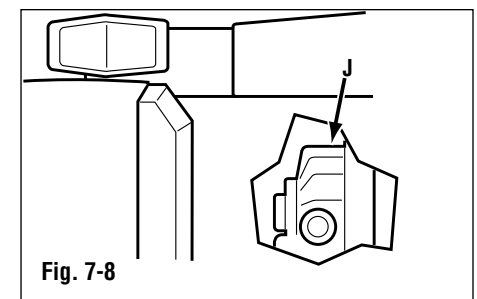
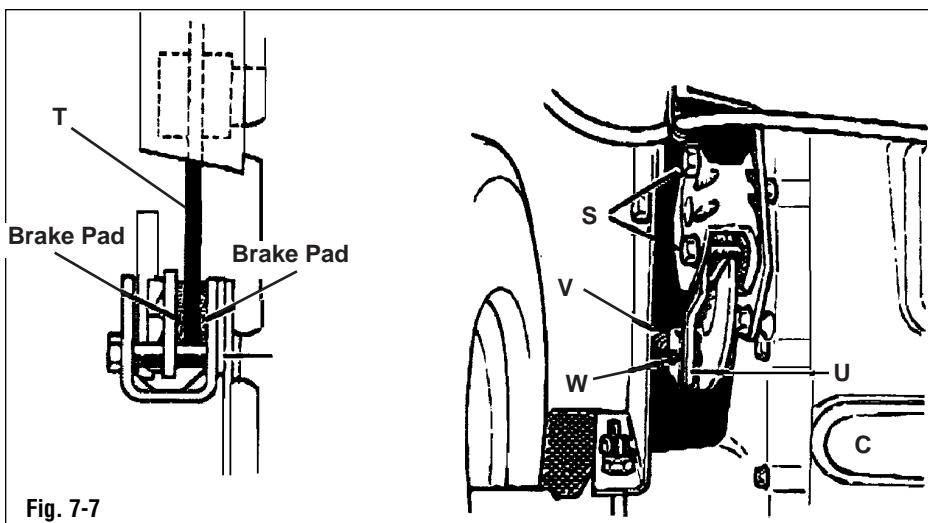

Maintenance (continued)

Transmission Oil Filter: Replace filter after first five hours and every 100 hours thereafter. Filter is located under the tractor, in front of the transmission.

Hydrostatic Neutral Adjustment

Hydrostatic neutral is set at the factory. If tractor creeps forward or backward while hydrostatic pedal is in neutral position, adjust as follows:

1. Shut off engine and wait for all moving parts to stop.
2. Jack or hoist rear of tractor so rear wheels clear ground. Place jack under transaxle housing.

⚠ WARNING

USE EXTREME CARE WHEN JACKING OR HOISTING TRACTOR. BLOCK WHEELS AND USE JACKSTANDS TO SECURELY HOLD UNIT IN PLACE.

KEEP CLEAR OF ROTATING DRIVESHAFT AND SPINNING FAN! CONTACT WILL CAUSE INJURY.

3. Remove tractor chassis tunnel (B, Fig. 7-9) by removing the four screws (Y) indicated.
4. Start engine and release brake.
5. Loosen capscrews (C). Move support plate (D) forward if wheel rotates in a forward direction or move support plate toward the rear if it rotates in reverse.

6. Tighten capscrews (C) when wheels no longer rotate.
7. Stop engine and lock brake arm against stop (E).
8. Loosen jam nuts (F). Adjust jam nuts to lengthen or shorten rod until pin enters slot (H) of neutral plate. Adjust until there is a gap of 1/16 - 1/8" between end of slot and pin.

⚠ CAUTION

INCORRECT ADJUSTMENT MAY DAMAGE PIN.

9. Tighten jam nuts (F).
10. Re-install chassis tunnel (B). Secure with screws removed earlier.

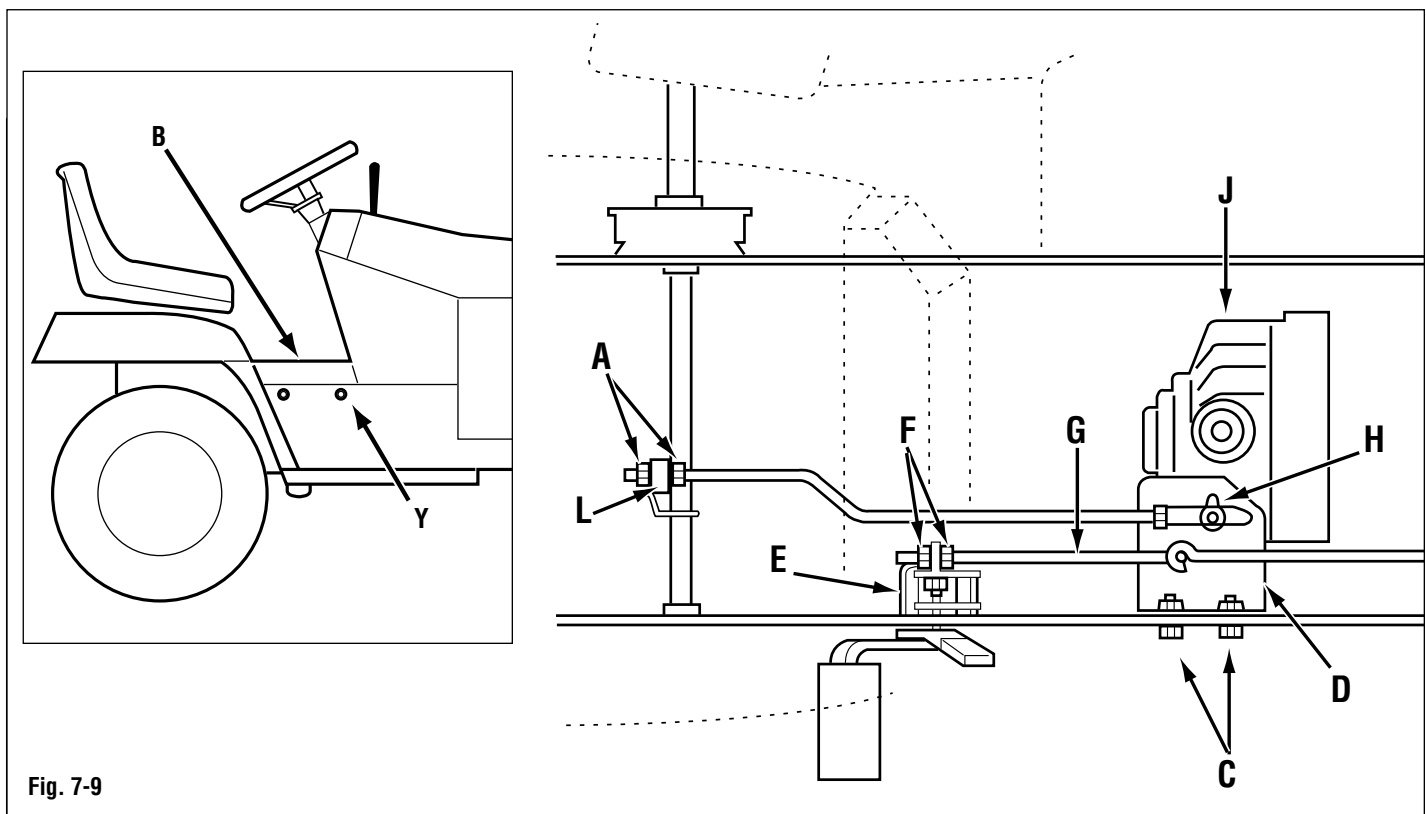

Fig. 7-9

Lubrication Chart

NOTE: A hand type grease gun is recommended when greasing your unit. High pressure type grease guns could cause damage to the fittings and bearing seals. Lubricate all linkages, levers and pins not equipped with grease fittings, with an oil can once each week; more often depending on operating conditions.

FRONT
View from
under tractor.

Lubricate from
both sides.

Item	Frequency	Type of Lubrication	Amt. Required
① Engine Crankcase	First 5 hours	See engine manual	See engine manual
	25 hours	Lubrication intervals vary with operating conditions and type of oil used	
② Hydrostatic Transmission	Check each use. Change when oil is discolored, dirty or after 100 hours	1-Speed Units: Use SAE 20 wt. Part No. 737-0335 2-Speed Units: Use Part No. 737-0333 (Benzoil Gear Hydro Oil) Alternate Oils - Mobil 423, Amoco 1000 or Texaco TDH	Fill to within safety operating zone
③ Front Wheel Spindles	25 hours or end of season	Multi-purpose grease	As required
④ Front Axle Pivot	25 hours or end of season	Multi-purpose grease	As required
⑤ Lift Shaft	25 hours or end of season	Multi-purpose oil	As required

Maintenance (continued)

Troubleshooting Chart

Possible Cause / Solution

Problem	Refer to engine manual.	Check attachment drive switch.	Check cruise relay, interlock and cruise switch.	Clean off engine fins.	Clean flywheel screen.	Faulty ignition.	Faulty spark plug.	Empty fuel tank.	Check battery or start solenoid.	Check carburetor.	Check oil.	Clean air cleaner.	Adjust choke.	Check cooling fins.	Check interlock switches at brake.	See your dealer.	Check linkage.	Inspect transmission.	Inspect belts.	Inspect Fuses	Travel pedal in reverse position.	
Engine turns over but won't start.	✓					✓	✓	✓		✓			✓			✓						
Engine will not turn over.	✓								✓							✓						
Engine doesn't turn over but start light comes on.		✓													✓							
Starts only after repeated tries.	✓					✓	✓			✓			✓			✓						
Stalls in a few seconds.	✓							✓		✓						✓						
Stalls when hot.	✓			✓	✓	✓	✓	✓		✓	✓	✓				✓						
Idles rough.	✓						✓	✓		✓			✓			✓						
Engine overheats.	✓			✓	✓	✓				✓	✓	✓		✓		✓						
Attachment drive inoperative.		✓														✓						✓
Cruise control inoperative.			✓													✓						
Excessive Vibration.	✓						✓				✓					✓	✓					
Engine runs but unit won't move.																✓	✓	✓	✓			
Headlights do not light.																✓					✓	

If you have any problems maintaining or servicing your unit, contact your dealer.

Storing the Tractor

Always store tractor in a dry and protected place when not in use. If tractor will not be used for a season, store it in the following manner.

1. **CLEAN:** Completely clean all accumulated dirt or grass from all parts – especially engine fins, transmission cooling fins and engine air intake screen.
2. **PROTECT FINISH:** Wipe oil or a rust preventative on any parts which may rust. Touch up any area where paint has been chipped or worn off. See parts list for Touch-up paint.
3. **TREAT FUEL:** Add gasoline stabilizer to fuel or move unit outside and run engine until it stops from lack of fuel.
4. **CHANGE ENGINE OIL:** Change engine oil while engine is still hot (See section 7).
5. **INSPECT/CLEAN FUEL AND AIR FILTER:** Check fuel filter and air cleaner. Replace if dirty or damaged. (See section 7.)
6. **SPARK PLUG:** Remove, clean and re-gap spark plugs. Place a small amount of oil (SAE 30) into each cylinder. Turn engine over a few times to fully lubricate the cylinder walls, valve seats and valve stems. This can be performed by engaging the key starter briefly. Replace spark plugs. (See section 7.)
7. **ATTACHMENT LIFT:** If tractor is stored with an attachment mounted on it, lower the attachment to the ground. Turn PTO/attachment drive switch to "OFF".
8. **PROTECT FROM ELEMENTS:** During the winter, store the tractor inside a building. If this is not possible, protect the tractor from rain, snow and ice with a Storage cover (Kit # 14077) or a waterproof tarp.
9. **ATTACHMENT/PTO:** After storage, operate the PTO clutch 10 to 15 times, at idle, before operation. (See page 15.)

DANGER

BATTERIES PRODUCE EXPLOSIVE GASSES. KEEP OPEN FLAMES AND SPARKS AWAY. DO NOT SET TOOLS ACROSS TERMINALS.

BATTERY ELECTROLYTE CAN CAUSE SEVERE BURNS. EYE CONTACT CAN CAUSE BLINDNESS. ALWAYS WEAR EYE PROTECTION AND RUBBER GLOVES WHEN WORKING NEAR BATTERY. NEVER WEAR JEWELRY.

IF ELECTROLYTE CONTACTS SKIN OR EYES, RINSE IMMEDIATELY WITH WATER FOR AT LEAST 15 MINUTES. CALL PHYSICIAN IMMEDIATELY.

Maintenance Chart

Interval	Item	Service
Each Use	Transmission Oil Air Intake Screen Engine Oil Level Mower Blades Loose or Missing Hardware Brakes Belts	Check Check Check Check Check Check Check
First 5 hours	Engine Oil and Filter Transmission Oil Filter	Replace Replace
Every 25 hours	Air Cleaner Pre-cleaner Transmission Cooling Fins Tires Brake Engine Oil	Clean Clean Check for wear and air pressure Check for wear and adjustment Change
Every 50 hours	Engine Cooling Fins Engine Oil Filter	Clean Replace
Every 100 hours	Air Filter Paper Element Transmission Oil Filter Fuel Filter Spark Plugs Transmission Oil	Replace Replace Change Replace, clean, reset gap Replace

10. **BATTERY:** Charge at 6-10 amps for one hour. Keep terminal posts cleaned of corrosion salts. Coat terminal posts with petroleum jelly or grease. Keep cables clean. Store at a cool temperature – 20° F to 50° F. Check every two months and charge as necessary. Keep cables and terminals clean. If cables are corroded, clean or replace them. (See section 7.)

For customer assistance, contact your nearest authorized dealer or:

GARDEN WAY INCORPORATED • 1 Garden Way • Troy, New York U.S.A. 12180

Customer Service: 1-800-437-8686 • Technical Service: 1-800-520-5520 • Parts Service: 1-800-648-6776 • FAX: (518) 391-7332

Outside the U.S.A. and Canada:

Customer Service: (518) 391-7007 • For Technical Service: (518) 391-7008 • Parts Service: (518) 391-7006 or FAX: (518) 391-7332

Free Manuals Download Website

<http://myh66.com>

<http://usermanuals.us>

<http://www.somanuals.com>

<http://www.4manuals.cc>

<http://www.manual-lib.com>

<http://www.404manual.com>

<http://www.luxmanual.com>

<http://aubethermostatmanual.com>

Golf course search by state

<http://golfingnear.com>

Email search by domain

<http://emailbydomain.com>

Auto manuals search

<http://auto.somanuals.com>

TV manuals search

<http://tv.somanuals.com>