

TROY-BILT®/Boiens.

Owner/Operator Manual

Mulching Mower Attachment

- Safety
- Assembly
- Operation
- Maintenance

Models

14049
14094

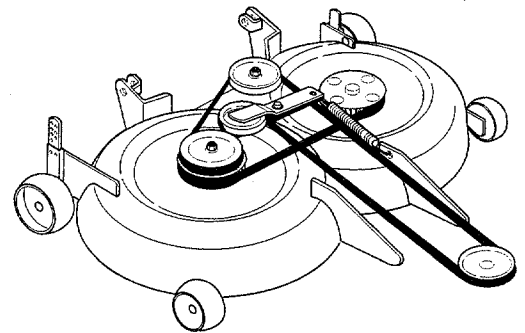

Thank you for purchasing this product. We feel you now own one of the finest pieces of outdoor power equipment available.

All information in this manual is based on the latest product information available at the time of printing.

This manual is considered a permanent part of this unit and it must stay with the unit if resold. A replacement manual can be obtained from the factory, free of charge.

This is a safety, operation and general maintenance manual which does not attempt to cover major repairs.

Our equipment is carefully designed, engineered and manufactured for excellent performance if properly operated and maintained.

Read this manual and review it frequently to familiarize yourself with the unit, its features and operation.

Our products have passed rigid safety standards of the Outdoor Power Equipment Institute and an independent testing laboratory.

The warranty for this unit appears on the tractor's owner/operator manual. Read it carefully. Also, please complete and return the postpaid owner registration card which is included with this manual. The purpose of this card is to register each unit and owner at the factory in order to keep the owner informed with informational bulletins and safety literature.

Table of Contents

Service Information	2	Frame-Hung Cutting	8
Identification Numbers	3	Raise or Lower Mower Deck	9
Safety	4	Mow at Full Throttle	9
Assembly and Installation	6	Mowing Tips	9
Install Discharge Chute	6	Maintenance and Lubrication	10
Install Mower Deck Onto Tractor	7	Mower Blades	10
Level Mower Deck	7	Lubrication	10
Operation	8	Blade Drive Belt Replacement	10
Before Operation	8	Cleaning	10
Ground Contour Cutting	8	Warranty	See Tractor's Manual

Service Information

Unit Service and Repair

To service your unit, contact your authorized dealer. Do not return parts directly to the factory. Provide your dealer with the unit's model/serial number and the part's description.

Warranty Service

Refer to the tractor's owner/operator manual for warranty information concerning this unit.

Left and Right Sides

Left and right sides of this unit are determined from the operator's position, facing the direction of forward travel.

Replacement Owner/Operator Manual

A replacement Owner/Operator Manual is available free of charge. To order, phone or write to the address on the back cover of this manual.

For prompt service, provide your authorized dealer with the identification numbers of the unit. Fill in the spaces below with these numbers for future reference.

Date of Purchase:

Unit Serial Number:

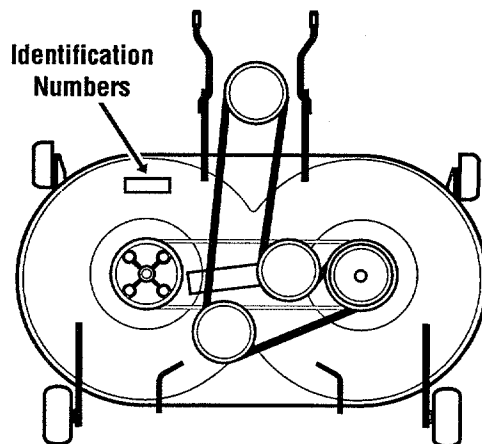

Section 1

Safety

Important! Safe Operating Practices for This Unit



This is a safety alert symbol. It is used in this manual and on the unit's decals to alert you to potential hazards. Whenever you see this symbol, read and obey the safety message that follows it. Failure to obey the safety message could result in personal injury or property damage.

Introduction

This machine is capable of amputating hands and feet and throwing objects. Failure to observe the following safety instructions could result in serious injury or death.

Serious accidents which may cause injury or property damage can occur if the following safety guidelines are not followed. The operator is responsible for accidents or hazards involving this unit. Preventing accidents is the responsibility of every equipment operator. Accidents can be prevented.

Be careful before, during and immediately after use of any powered equipment. The following general safety precautions must be fully understood and followed during operation. Review these instructions frequently and never take chances. If you do not understand any part of this manual or need assistance, contact your dealer or our service department.

First

- Read the Owner/Operator Manual for the tractor to be used with this unit.
- Only allow responsible adults, who are familiar with the instructions, to operate unit.
- Know the location and function of all controls before operating unit. Know how to stop engine and attachments quickly in case of emergency.

Safety (continued)

- Familiarize yourself with all safety and operation decals on unit and attachments. If these decals are damaged or not legible, clean or replace them as needed.
- Never allow children to operate unit, even under adult supervision. Local regulations may restrict operator age. Only allow responsible adults, who are familiar with these instructions, to operate this unit.
- Wear proper clothing when operating unit. Always wear sturdy footwear (preferably steel-toed shoes) and hearing protection during operation.
 - a. Wear heavy leather gloves whenever servicing unit.
 - b. Do not wear loose-fitting clothing, jewelry, scarves, ties, etc., which may get caught in moving parts. Tie up or restrain long hair.
 - c. Do not operate unit while barefoot. Do not wear sandals.
 - d. Wear long trousers.
 - e. Wear hearing protection and safety glasses with side shields.
- Do not operate this unit when tired, ill or under the influence of alcohol and/or other drugs.

Before Operation

- Clear work area of objects such as rocks, toys, wire, etc., which could be picked up and thrown by mower blades.
- Keep unit in safe operating condition. Check all hardware for tightness (especially blade mounting hardware—check for proper torque specifications frequently in this area, see page 10).
- Inspect mower blades for wear or damage. Broken pieces thrown from a worn or damaged blade can cause serious injury.

- Do not operate unit without safety devices and shields in place and operating properly.
- Use this attachment only on tractors approved for use with this attachment. Contact our service department to determine whether this attachment is approved for use with a specific tractor.
- **CORRECT ANY MALFUNCTION BEFORE USING THIS UNIT!**



Operation

- Remain seated when starting engine and during operation. Do not try to stabilize unit by putting your foot to the ground.
- Keep hands, feet, face, hair and clothing away from rotating parts. Stop engine before removing grass catcher or unclogging chute.
- Be aware of attachment discharge direction and do not point it at anyone. Do not operate unit without either the entire grass catcher or the guard in place.
- Be sure area is clear of other people before mowing. Stop unit if anyone enters the area. Do not operate this unit with children, pets or others nearby.
- Always observe the terrain. Watch for and avoid obstacles. Stay away from holes, ditches, soft or steep embankments and other potentially dangerous terrain. Tall grass can hide obstacles.
- Never leave machine unattended.
- Watch for traffic when operating near or crossing roadways.

- If you strike a foreign object, disengage attachment (PTO) drive, shut off engine, wait for all moving parts to come to a stop and remove ignition key. Inspect for and repair any damage before operating equipment again.
- Do not mow in reverse unless absolutely necessary. If it is absolutely necessary to mow in reverse:
 - a. Check area on the ground directly behind unit.
 - b. Continue to observe area down and to rear while running in reverse.
- Turn off blades/disengage attachment /PTO drive when transporting unit to the work area or when attachments are not in use.
- Mow only in daylight or in good artificial light.
- Never dismount to make a cutting height adjustment while the engine is running.
- Shut off engine and disengage attachment/PTO drive, set parking brake and remove key before leaving unit and unclogging discharge chute or mounting the grass catcher.
- Never dismount tractor to make a cutting height adjustment while engine is running.



Children

- Tragic accidents can occur if the operator is not alert to the presence of children. Children are often attracted to the machine and the mowing activity. Never assume that children will remain where you last saw them.
- Never allow children to operate unit, even under adult supervision. Local regulations may restrict operator age.

- Keep children out of work area and under the watchful care of another responsible adult. Be alert and turn unit off if children enter the area.
- Before and when backing, look behind and down for small children.
- Never carry children or passengers. They may fall off and be seriously injured or interfere with safe machine operation.



Slope Operation

- Slopes are a major factor in loss-of-control and tip-over accidents which can result in severe injury or death. All slopes require extra caution. If you cannot back up the slope or if you feel uneasy on it, do not operate unit on the slope.
 - Always mow up and down the face of slopes, never across. Use slow speed on slopes and operate in a low gear and avoid shifting on slopes.
 - Do not turn on slopes unless necessary and then, turn slowly and gradually downhill, if possible. Do not mow on wet grass. Reduced traction could cause sliding.
 - Do not mow near dropoffs, ditches or embankments. Unit could suddenly overturn if a wheel goes over the edge of a cliff or ditch, or if an edge caves in.
 - Do not operate unit on steep slopes where there is a risk of over-turning. Do not mow slopes with an incline of more than 10°.
 - If the tractor is unable to continue moving uphill, disengage the attachment-PTO drive, check area on ground immediately behind unit, watch area to rear and proceed backward slowly.
- Watch for holes, ruts, or bumps. Uneven terrain could overturn machine. Tall grass can hide obstacles.
 - Follow manufacturer's recommendations for wheel weights (for added stability) when using attachments.
 - Use extra care with grass catchers or other attachments. These can change the stability of the machine. Do not use grass catcher on steep slopes.
 - Do not try to stabilize unit by putting your foot to ground.
 - Disengage attachment (PTO) drive when transporting tractor or when attachments are not in use.

Maintenance

- Before performing any service, adjustments or maintenance on unit:
 - a. Park the tractor on a firm and level surface.
 - b. Disengage attachment/PTO drive.
 - c. Lower the attachments.
 - d. Move all control levers to neutral.
 - e. Apply parking brake.
 - f. Shut off engine. Remove ignition key and allow engine to cool.
 - Always wear sturdy footwear, long trousers, hearing and eye protection while doing any maintenance on this unit.
 - Do not wear loose-fitting clothing, jewelry, scarves, ties, etc., which could get caught in moving parts. Tie up or restrain long hair.
 - Mower blades are extremely sharp. Use caution when servicing. Wear gloves or wrap blades in rags. Wear eye protection when sharpening blades.
 - Keep all safety and operation decals in place. If these decals are damaged or not legible, clean or replace them as needed.
- Keep children away while performing maintenance or adjustments.
 - Chock wheels (place block of wood on both side of wheels) when performing maintenance with parking brake off. If unit must be raised for any reason, be certain it is securely supported.
 - Provide safe, adequate light in your work area. **NEVER USE AN OPEN FLAME FOR ILLUMINATION!** Use only a portable safety light enclosed in a wire cage for working inside or under unit. Hot filaments from a broken light bulb can ignite spilled fuel or oil.
 - Keep nuts and bolts tight, especially blade attachment bolts (check for proper torque specifications frequently in this area). Keep equipment in good condition.
 - Never tamper with safety devices. Check for proper operation regularly.
 - Keep machine free of grass, leaves, or other debris build-up. Clean up oil or fuel spillage. Allow machine to cool before storing.
 - Frequently check components and replace when necessary. Use only factory-approved replacement parts. Parts manufactured by others may present safety hazards even though they may fit on unit.

Section 2

Assembly and Installation

Install Mower Deck onto Tractor

1. Secure each gage wheel assembly (X, Fig. 1) to mower deck with clevis pin and cotter spring.
2. Slide mower deck under tractor.
3. Attach front lift rods (A, Figs. 1 & 2) to mower deck as illustrated. Lift rods are not inter-changeable. Short bent ends face to the outside of mower deck and must be installed as illustrated in Figs. 1 and 2.

WARNING

LOCK LIFT LEVER DOWN WHEN SECURING LIFT BRACKETS TO LIFT LINKS. LIFT LINK IS SPRING LOADED! POSSIBLE INJURY FROM SCISSOR ACTION OF LIFT LINK MAY RESULT!

4. Secure lift brackets (D) (on deck) to lift links (E) (on tractor) as follows:
 - a. Raise lift arm (E) and turn height adjustment knob in the (-) direction to lowest setting. (See inset, Fig. 6, page 9)

- b. Lower and lock attachment lift lever into down position. See page 9, "Raise or Lower Mower Deck" for locking instructions.
 - c. Line up holes on lift bracket (D, Figs. 1 and 2) with hole on lift link (E). Insert clevis pin (F) through lift bracket first, then through lift link. Secure with hitch pin. Repeat on other side.
5. Attach front lift rods (A) to front hitch points (B) on tractor, over studs. Secure with click pins (C).
 6. Secure drive belt (G) to tractor PTO sheave (H).

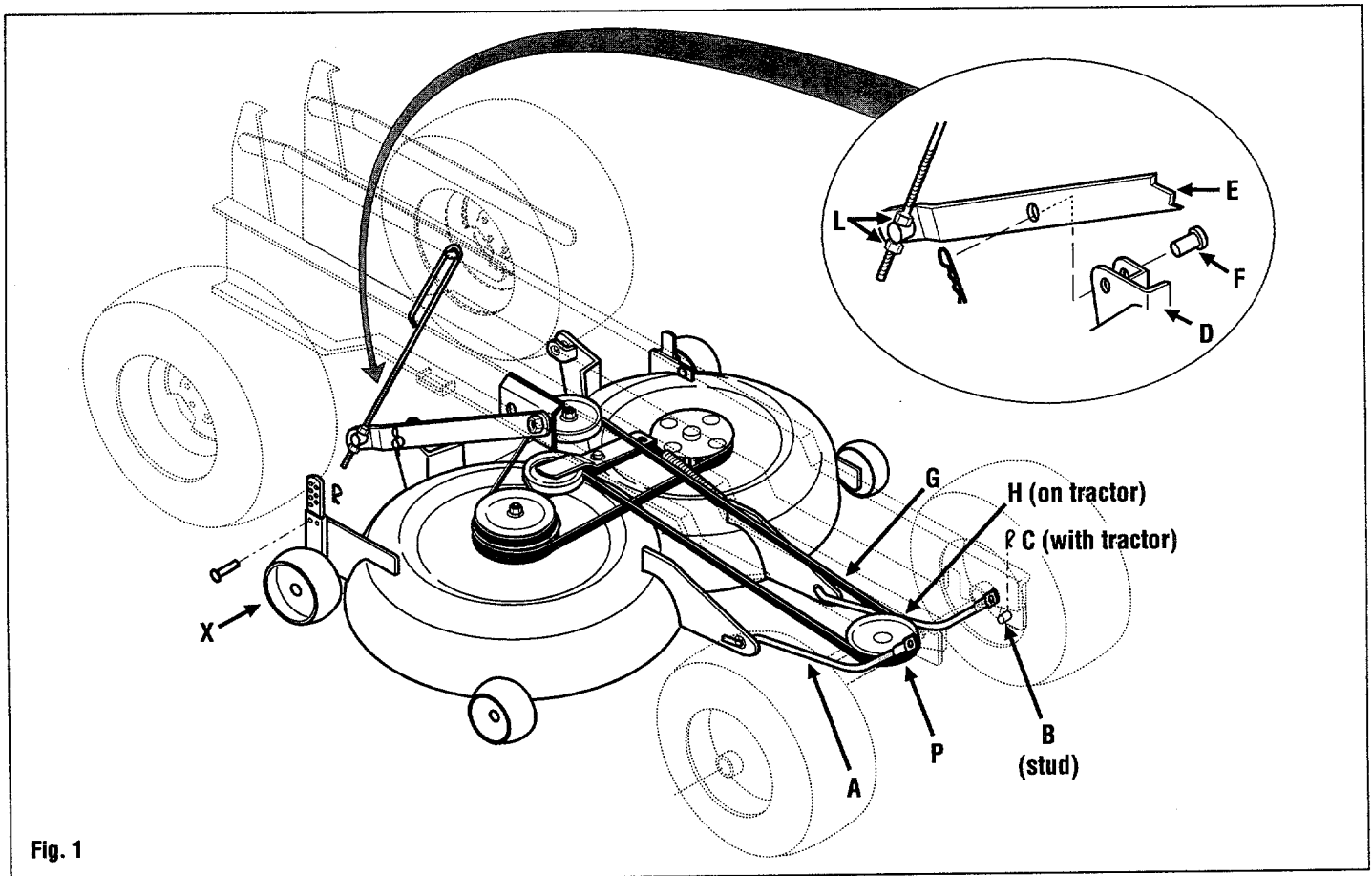
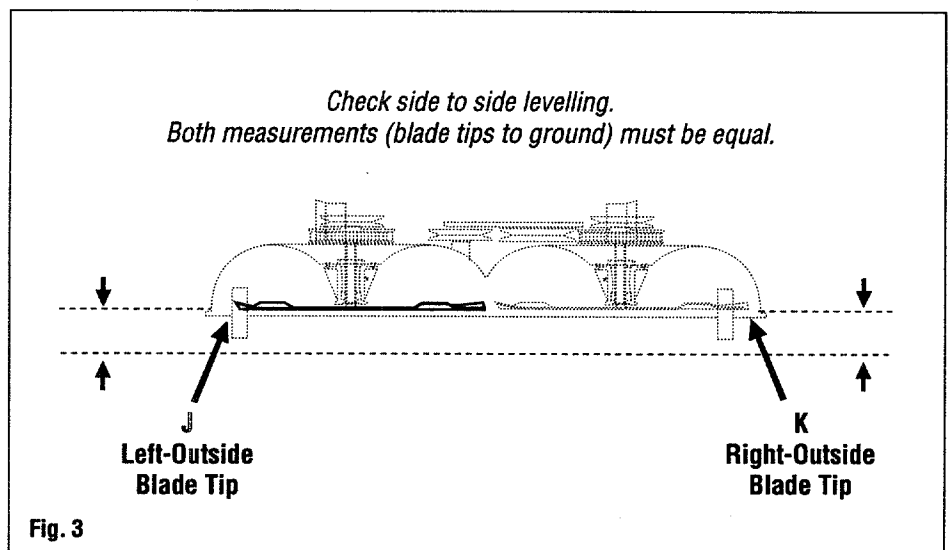
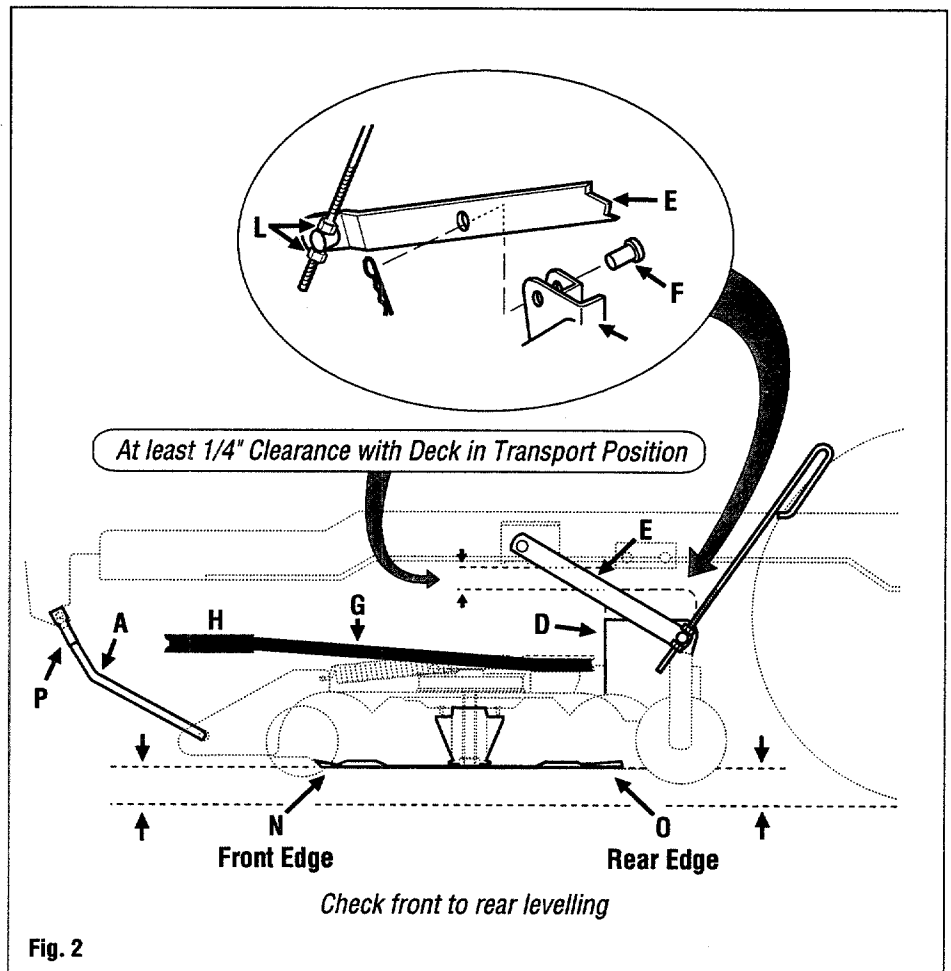

Fig. 1

Level Mower Deck

1. Park tractor with attachment on a level surface. Raise mower to transport position (see page 9).
2. Check and adjust tractor tire pressure:
 - Front: 12 - 14 PSI (82 - 96 kPa)
 - Rear: 8 - 10 PSI (55 - 69 kPa)
3. Set clearance between lift bracket (D, Fig. 2) and frame (frame stop on some models) to 1/4". Adjust position of nuts (L) to set clearance.
4. Level deck – front to rear:
 - a. Lower mower deck to height of 3".
 - b. Turn left or right blade so it aligns lengthwise (front to rear) with tractor. Measure distance from front edge of blade (N, Fig. 2) to ground. Measure distance from rear edge of blade (O) to ground. Both distances should be equal.
 - d. To level, adjust length of front lift rods (A) (Figs. 1 and 2) by turning rod end (P) on each front lift rod, up or down threads.
5. Level deck – side to side:
 - a. Lower mower deck to ground.
 - b. Turn left blade so it aligns widthwise (perpendicular) to tractor. See Fig. 3. Measure distance from outside blade tip (J) to ground. Turn right blade so it aligns widthwise (perpendicular) to tractor. Measure distance from outside blade tip (K) to ground. Measurements should be equal.
 - c. Adjust position of nuts (L, Figs. 1 and 2) to raise or lower each lift link until deck is level from side to side.
 - d. When level, tighten nuts (L) firmly against swivel block.

NOTE: CLEARANCE BETWEEN LIFT LINK (E) AND LIFT BRACKET (D) MUST BE NO LESS THAN 1/4" WHEN DECK IS IN TRANSPORT POSITION.



Section 3

Operation

⚠ CAUTION

BEFORE OPERATION, REMOVE STONES, WIRE, ETC. FROM MOWING AREA. AVOID STRIKING PROTRUDING OBJECTS (PIPES, ROOTS OR EARTH MOUNDS). NEVER PLACE HANDS OR FEET UNDER MOWER BASE WHEN ENGINE IS RUNNING OR WHEN ATTACHMENT/PTO DRIVE IS ENGAGED. NEVER OPERATE MOWER WITHOUT DISCHARGE CHUTE PROPERLY INSTALLED. FAILURE TO FOLLOW THESE INSTRUCTIONS MAY RESULT IN PERSONAL INJURY OR PROPERTY DAMAGE.

Before operation, read tractor owner-operator manual. Read and understand all safety instructions before operating.

Adjust Anti-scalp Wheels

Secure front anti-scalp wheels (A, Fig. 4) to top hole in mounting bracket when cutting at a height less than 3". Secure to bottom hole when cutting at a height more than 3".

Before Operation

1. Re-check all nuts and bolts for tightness after initial run-in of 2 to 4 hours of operation.
2. Check for loose or missing hardware. Repair or replace as necessary.

Operation

1. Disengage attachment/PTO drive before attempting to start engine.
2. Once engine is started and running, operate at full throttle.
3. Engage attachment/PTO drive switch to activate mower deck.
4. Lower mower deck (see page 9).

This tractor/mower deck combination provides the operator with an adjustable lift system and two cutting methods.

It is possible to customize tractor lift mechanism and cutting method to preference. Spring tension of lift can be increased to provide more assistance when raising mower deck to transport position. To adjust spring tension, refer to tractor owner/operator manual.

"Frame hung cutting" is preferred in most circumstances, specifically when cutting on relatively flat, smooth terrain. Use "ground contour cutting" when cutting on rough, uneven terrain. Cutting methods are described below.

Cutting Method 1: Ground Contour Cutting (Regulated by Gage Wheels)

Use "ground contour cutting" when cutting on rough, uneven terrain. This method allows mower deck to follow ground contours while cutting. When "ground contour cutting", mower deck weight is supported by rear gage wheels. Height is regulated by position of rear gage wheels.

To cut following ground contours:

1. Raise mower deck to transport position. Turn height adjustment knob (B, Fig. 6) to lowest position. *Turn knob in the (-) direction until it stops.*
2. Adjust cutting height at rear gage wheels:
 - a. Remove cotter spring and clevis pin (C, Fig. 4).
 - b. Move each rear gage wheel (D) up or down to select cutting height. (Set each gage wheel to the same height.)
 - c. Secure each gage wheel in position with clevis pin (C) and cotter spring as illustrated.
3. Cut with lift lever (E, Fig. 6) locked down in lowered position.

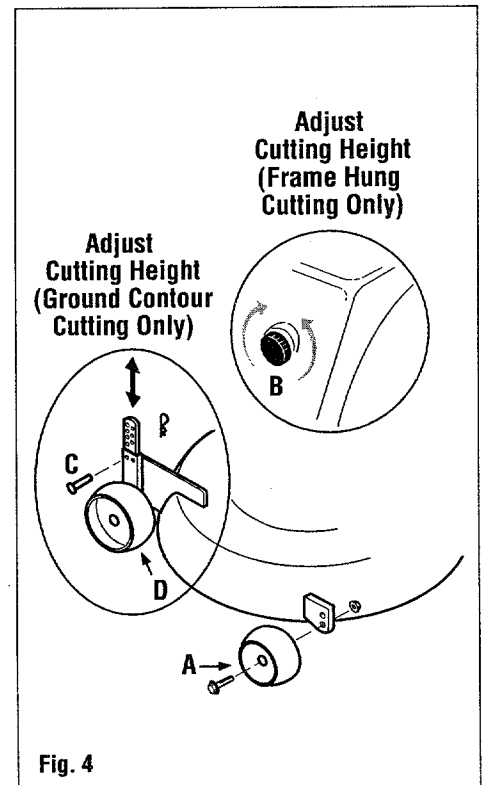

Fig. 4

NOTE: HEIGHT ADJUSTMENT KNOB MUST BE TURNED TO LOWEST POSITION WHEN "GROUND CONTOUR CUTTING".

Cutting Method 2: Frame Hung Cutting (Regulated by Height Adjustment Knob)

"Frame hung cutting" reduces wear on mower deck and is recommended when cutting over smooth terrain. With this method, mower deck hangs from tractor frame. If deck contacts a bump, front anti-scalp wheels and rear gage wheels contact ground and lift deck to avoid scalping. When mower deck has passed bump, deck returns to hanging position.

To cut with mower hanging from frame:

1. Raise mower deck and lock into transport position.
2. Adjust cutting height at height adjustment knob (B, Fig. 4 & 6):
 - a. Turn knob in the (+) direction to raise cutting height. Turn knob in the (-) direction to lower cutting height.
 - b. After cutting height is selected, lower attachment. Set rear gage wheel ground clearance to 1/4". See Fig. 5. Lift gage wheel up (about one hole more) to clear ground by 1/4".
 - c. Check cutting height. Raise attachment and repeat step 2 if necessary.
3. Cut with lift lever (E, Fig. 6) locked down in lowered position.

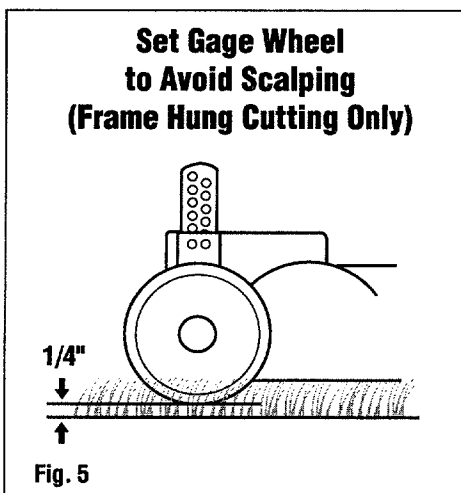

Raise or Lower Mower Deck

To raise or lower mower deck, first unlock lift, then raise or lower lever.

1. Unlock lift.

TO UNLOCK LIFT WHEN IN RAISED POSITION: Pull lift lever (E, Fig. 6) up slightly to unload lift mechanism. Press button at front of lift lever to release lock.

TO UNLOCK LIFT WHEN IN LOWERED POSITION: Push lift lever (E) down slightly to unload lift mechanism. Press button at front of lever to release lock.

2. Raise or lower lift lever.

TO RAISE OR LOWER LIFT: Release button. Pull lift lever (E) up to raise attachment, push down to lower attachment. To lock, push lever completely down (or up) until button pops out.

TO LOCK LIFT DOWN: Push lever completely down until button pops out.

Mow at Full Throttle

Always run engine at full throttle for best performance. Running engine at low throttle settings can cause engine to overheat by reducing air flow and may discharge battery.

Mowing Tips

If grass is longer than usual, cut at a reduced ground speed and a higher cutting height. Make two passes if necessary. Resume cutting at usual height in a few days. If grass is extremely long, cut 1/2 to 3/4 of normal cutting width, overlapping previous cutting path.

Always overlap left wheel tracks of previous cut to allow blades to cut grass which was tramped down by wheels. This practice helps reduce uncut patches. Avoid cutting wet grass. Wet grass, when cut, may form clumps.

During a hot and dry season, allow grass to grow longer – allowing roots to penetrate deeper. Longer grass keeps soil cooler and holds moisture better.

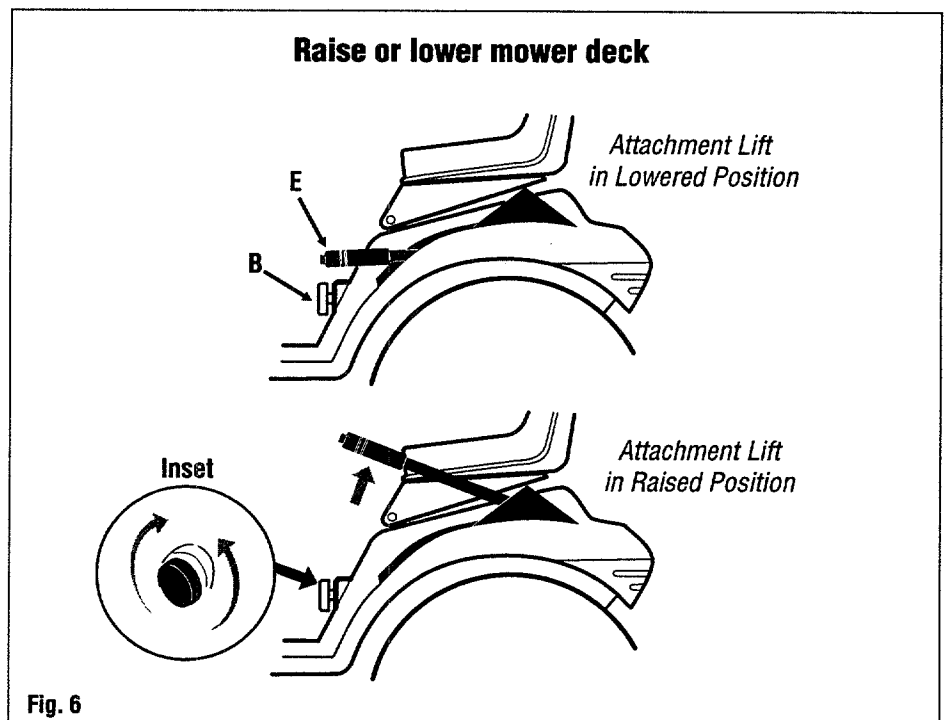

Maintenance and Lubrication

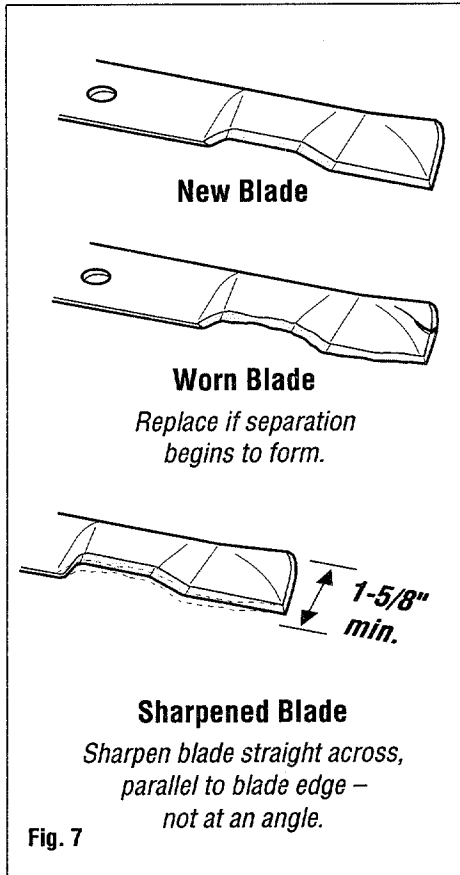

⚠ WARNING

BEFORE PERFORMING ANY MAINTENANCE, OR ADJUSTMENTS TO THE UNIT, SHUT OFF ENGINE, REMOVE KEY AND DISENGAGE ATTACHMENT/PTO DRIVE. WAIT FOR ALL MOVING PARTS TO STOP. FAILURE TO FOLLOW THESE INSTRUCTIONS MAY RESULT IN PERSONAL INJURY.

Mower Blades

Examine mower blades before each use. Check for blade wear. See Fig. 7.

⚠ WARNING

BEFORE REMOVING OR REPLACING THE MOWER BLADES, SHUT OFF ENGINE, REMOVE KEY AND DISENGAGE ATTACHMENT/PTO DRIVE. USE CAUTION WHEN SHARPENING MOWER BLADES. WEAR GLOVES OR WRAP MOWER BLADES WITH RAGS.

Mower Blade Maintenance (continued)

Blade Sharpening:

Grind or file the same amount from each blade end to maintain mower blade balance. An unbalanced mower blade produces excessive vibration and may damage spindle bearings. Sharpen cutting edge straight across – parallel to rear edge of mower blade. See Fig. 7. After sharpening, check mower blades on a blade balancer.

Blade Installation:

Install mower blades (B) as shown in Fig. 8 with flat side down. Blades are identical and may be installed randomly on each spindle. Torque bolts (A, Fig. 8) to 35 ft. lbs. (47 Nm).

Lubrication

The mower deck has two grease fittings (C, Fig. 8 and 9), beneath the mower deck on each blade spindle. See Figs. 8 and 9.

1. Lubricate gage wheels (D, Fig. 9) and anti-scalp wheels (E) with oil every 100 operating hours or twice yearly.
2. Lubricate spindle grease fittings:
 - a. Remove mower deck (page 11) and turn it upside down. Clean fittings before lubricating.
 - b. Lubricate grease fittings every 50 hours of operation or yearly with multi-purpose grease. (2 - 3 strokes from a grease gun per fitting.)

Mower Blade Maintenance

For efficient mowing, always keep cutting edges of mower blades sharp. Examine mower blades for wear. Re-sharpen blades when they begin to dull.

Blade Removal:

Remove bolt (A, Fig. 8) and washer. Remove mower blade (B).

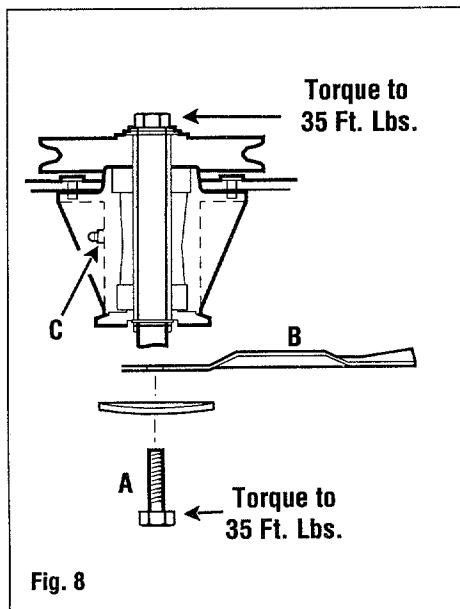

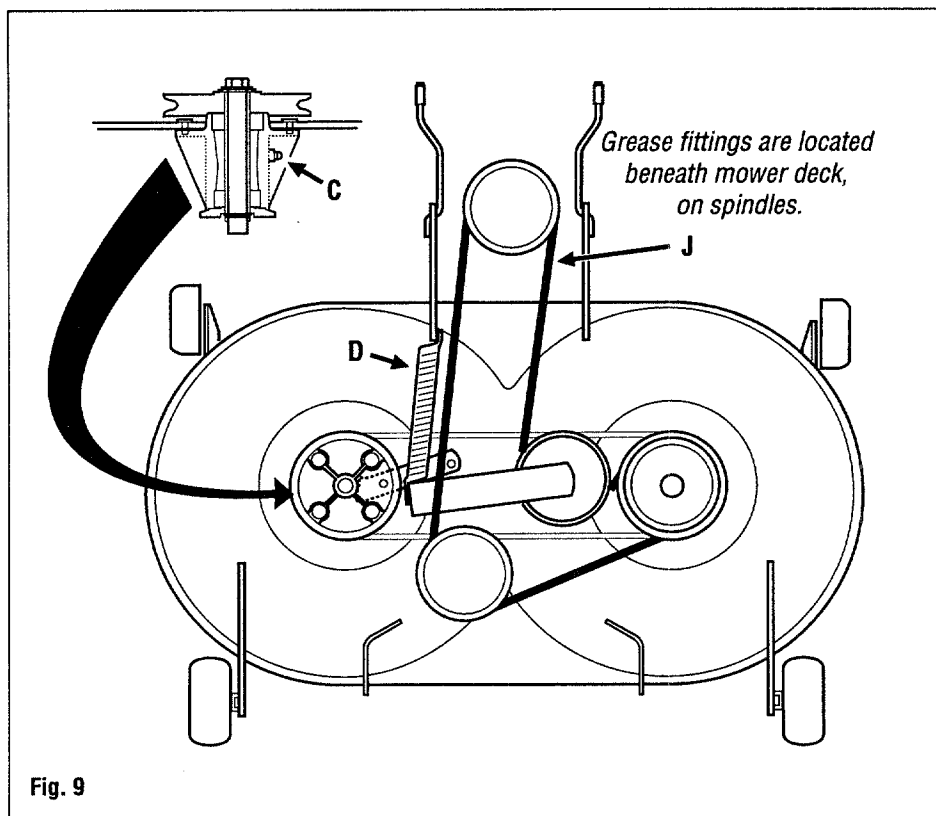

Fig. 9

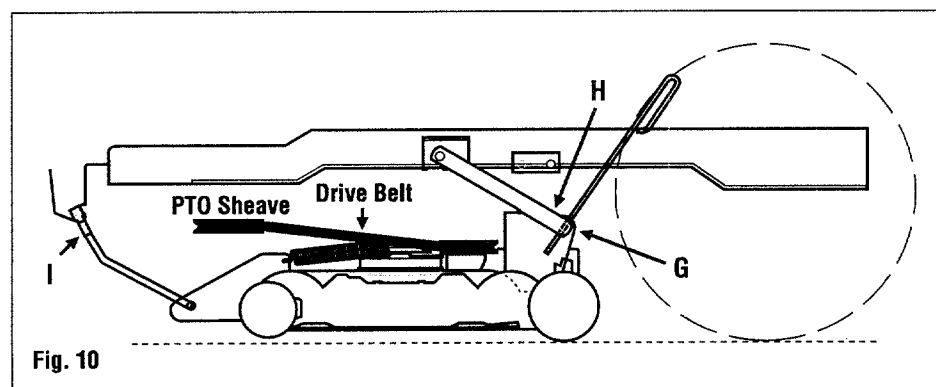

Fig. 10

Blade Drive Belt Replacement

1. Remove mower deck from tractor.
2. Remove spring (D, Fig. 9). Remove attachment/PTO drive belt (J).
3. Loosen screws (E, Fig. 11) and push sprocket in (toward center) to free blade drive belt.
4. Position blades so they are perpendicular to each other. **BLADES MUST BE ALIGNED 90° TO EACH OTHER.**
5. Place new belt with toothed edge in grooves on each sprocket.
6. Tighten belt by pulling belt tensioning bracket (F) rearward. This slides sprocket outward.
7. When belt is tight (deflection of 1/4"), hold sprocket and tighten screws (E).
8. Re-install attachment/PTO drive belt (J, Fig. 9) and re-install spring (D).

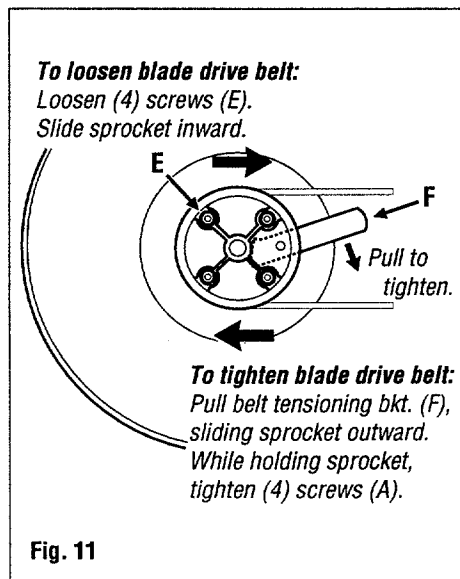

Fig. 11

Mower Deck Removal

1. Shut off engine, remove key and disengage attachment/PTO drive. Lower mower deck to ground and lock in down position.

⚠ WARNING

LOCK LIFT LEVER DOWN. LIFT LINK IS SPRING LOADED!

2. Remove click pin and clevis pin from lift bracket (G, Fig. 10), releasing lift bracket from lift link (H).
3. Pull click pin from stud at rod ends (I). Disconnect rod ends from studs on frame.
4. Remove lift rods. Pull mower deck out from under tractor.

Cleaning

Keep mower deck clean. Use a high pressure air hose if possible to blow off grass and dust.

If an air hose is not available, clean deck with water. Dry mower deck by running it for 5 to 10 minutes without cutting grass.

GARDEN WAY, INCORPORATED
215 South Park Street • Port Washington, Wisconsin 53074 • (414) 284-5521

Free Manuals Download Website

<http://myh66.com>

<http://usermanuals.us>

<http://www.somanuals.com>

<http://www.4manuals.cc>

<http://www.manual-lib.com>

<http://www.404manual.com>

<http://www.luxmanual.com>

<http://aubethermostatmanual.com>

Golf course search by state

<http://golfingnear.com>

Email search by domain

<http://emailbydomain.com>

Auto manuals search

<http://auto.somanuals.com>

TV manuals search

<http://tv.somanuals.com>